

YAMAHA

Multitrack Cassette Recorder

MT4X

User's Guide

Manuel de l'utilisateur

Bedienungsanleitung

Guía del Usuario

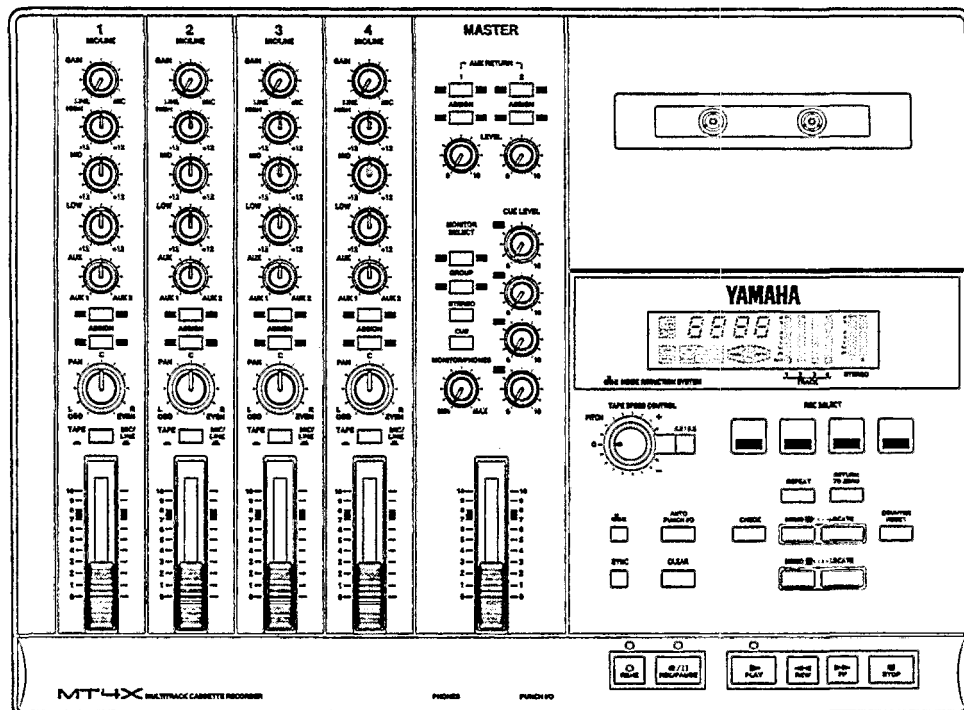

Precautions

- 1 Avoid excessive heat, humidity, dust, and vibration.**
Keep the MT4X away from locations where it is likely to be exposed to high temperatures or humidity, such as direct sunlight, near radiators, stoves, etc. Also avoid locations which are subject to excessive dust accumulation or vibration which could cause mechanical damage.
- 2 Avoid physical shocks**
Strong physical shocks can cause damage. Handle the unit with care.
- 3 Clean with a soft dry cloth**
Never use solvents such as benzine or thinner to clean the MT4X. Wipe it clean with a soft dry cloth.
- 4 Do not open the case or attempt repairs or modification yourself**
The MT4X contains no user-serviceable parts. For other than routine cleaning, refer all maintenance to qualified YAMAHA service personnel. Opening the case and/or tampering with the internal circuitry will void the warranty.
- 5 Make sure power is off before making or removing connections**
Always turn the power OFF prior to connecting or disconnecting cables. This will prevent damage to the MT4X as well as other connected equipment.
- 6 Handle cables carefully**
Always plug and unplug cables — including the AC cord — by gripping the connector, not the cord.
- 7 Always use the correct power supply**
The MT4X is sold configured to the appropriate power specifications for the local area. The power supply voltage and power consumption are listed on the bottom panel. If you move

to an area with a different AC mains voltage, be sure to check with your nearest YAMAHA dealer before using the unit.

- 8 Keep the heads and tape path clean**
To ensure consistent high performance and sound quality from the MT4X, it is important to clean the heads and tape path regularly — ideally before each recording session. Use a cleaning kit specifically designed to use with cassette tape equipment.
- 9 Use only high-quality chrome cassette tape**
The MT4X is designed to be used with Chrome tape (CrO₂ tape — Bias: HIGH or TYPE II position; EQ: 70µs). It will not work properly with Ferrichrome tape formulations. You may experience high frequency distortion if you use such tapes. The use of tapes longer than 90 minutes (C-120 and longer) is not recommended. These tapes are much thinner and therefore prone to poor performance or failure. TDK SA 46 - 90 and Maxell XLII 46 - 90 are recommended.
- 10 Handle the cassette tapes properly**
You should fast forward and rewind new tapes before you record on them. This will prevent any possible binding that could be caused by the tape being tightly wound at the factory. It is best not to use the first and last 20 seconds of a tape. The splice between the leader and the tape can cause distortion. When loading a cassette, check that the tape is not loose, then load the tape firmly into the cassette compartment. If the tape is not loaded properly, the unit may jam or otherwise malfunction.
- 11 Use the dbx™ switch correctly**
To obtain the best possible sound quality, you should always use the dbx™ noise reduction system to playback tapes that were recorded with the dbx™ system on. If the tape was recorded without dbx™, turn the noise reduction system off. The dbx™ noise reduction system was manufactured based on a patent licence from THAT Corporation. dbx is a trademark of Carillion Electronics Corporation.

Contents

Precautions	1	Punch-in/out recording	21
Introduction.....	2	Ping-pong recording	29
Features	2	Mixdown.....	32
Structure of the MT4X	3	4 Synchronization	34
1 Controls and Connections	5	FSK recording	35
Channel Modules	6	Synchronized playback	36
Master Module.....	7	Synchronized mixdown	39
Recorder Controls	8	5 Memory Functions.....	41
Transport Controls	10	Memo Function.....	41
Multi-function Display	10	Repeat Function	42
Front Panel Connections	11	Recording Levels Function.....	42
Rear Panel Connections.....	12	Appendix	44
Power Connections	13	Troubleshooting	44
2 Example System	14	Maintenance	45
3 Recording Functions.....	15	Specifications	46
Monitoring.....	15	Block Diagram.....	48
Initial recording	16	Dimensions	49
Overdubbing	19	Tracking Sheet.....	49
		Glossary	51

Introduction

Your MT4X Multitrack Cassette recorder is a powerful recording tool that will allow you to capture your music at a very high level of sound quality. It is an advanced technology, easy-to-use four-track cassette tape recorder with a comprehensive four-channel mixer.

In order to make use of the many features of the MT4X and to obtain the best performance, please read this manual thoroughly — and keep it in a safe place for future reference.

Features

General

The MT4X consists of a four-channel mixer section and a four-track cassette tape recorder section inside a compact enclosure. Independent recording and playback is possible for each track. This allows you to create high-quality multi-track recordings.

Mixer

- The mixer section is equipped with independent stereo buses for greater flexibility.
- Continuously variable gain controls are provided for each input channel. These can be used with any input source, from microphones to electronic instruments.
- Each channel has a three band equalizer (HIGH, MID, and LOW) giving you flexible tone-shaping capabilities.
- Dual AUX SEND and AUX RETURN (stereo) connectors allow you to add effects from external signal processors. You can assign the AUX RETURN signal to each channel as required.

Recorder

- The dbx™ noise reduction system provides substantial noise reduction and a wide dynamic range.
- An automatic punch-in/out recording function and a rehearsal function make recording easier and more accurate. Locate functions, such as memory and return-to-zero are provided for additional convenience.
- A large, multi-functional display shows the recording and playback levels, along with a tape counter and other indicators, giving you immediate and helpful information about the status of the MT4X.
- The pitch control allows you to vary the tape speed with in a range of approximately $\pm 10\%$. This can be useful when you have to compensate for pitch variations during an overdub.
- The tape transport is a full-logic mechanism, making recording and playback operation smooth and simple.
- The transport offers two speeds: 9.5 cm/sec and 4.8 cm/sec.

Structure of the MT4X

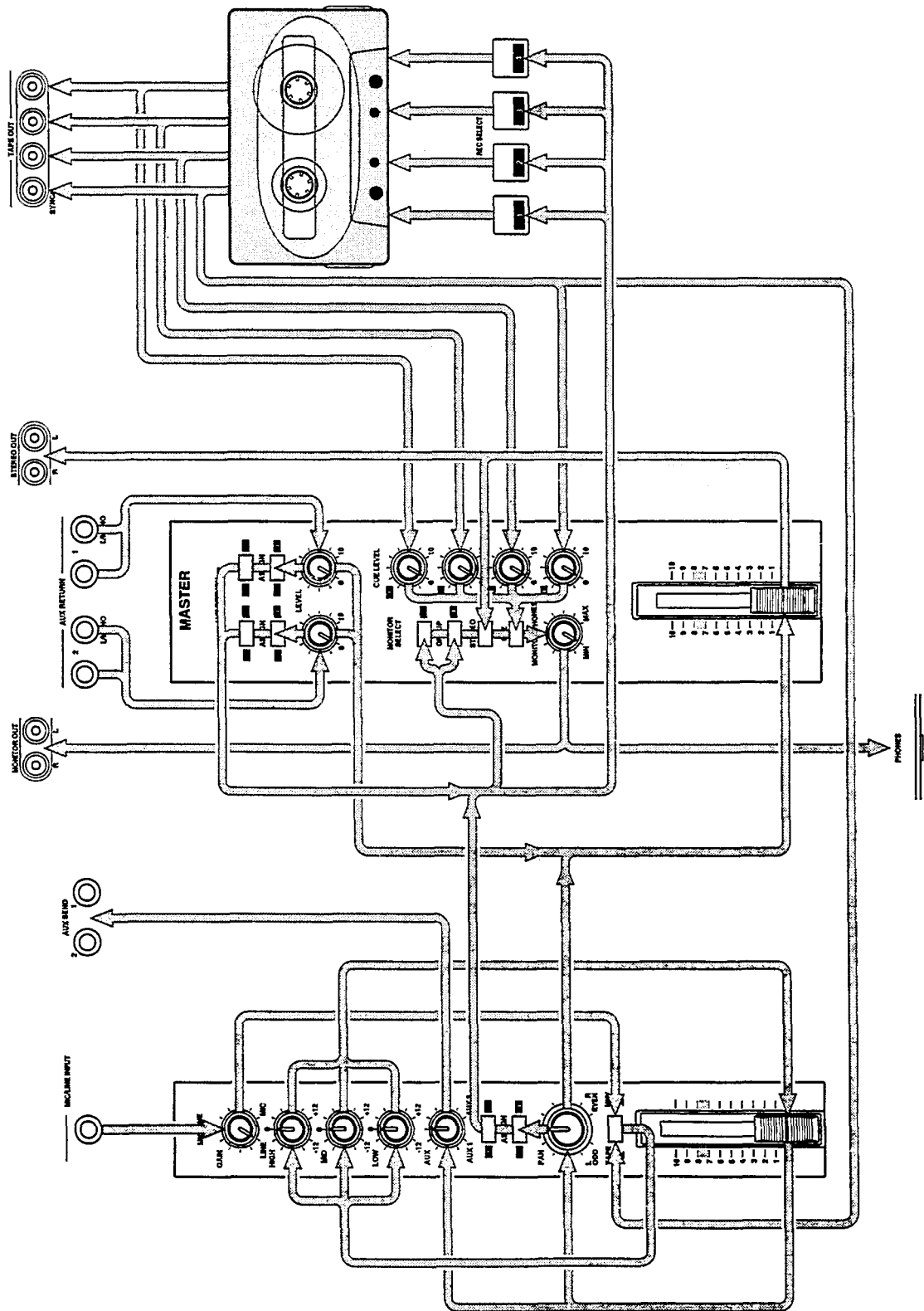

Structure of the MT4X

The MT4X can be divided into three basic sections - the mixer, the recorder, and the bus lines which connect them:

Mixer

The mixer has four input channels. It adjusts the input signals at each respective channel and sends them to the bus lines.

The signals input to each channel of the mixer can be switched to either input signals (MIC/LINE) or playback signals (TAPE). When TAPE is selected, the playback signal from each track is input to the corresponding channel. The tone of the signal is adjusted through the equalizer and the volume at the channel faders. It is then sent to the bus lines using the ASSIGN keys and PAN control.

Bus Lines

There are four main bus lines (group buses) which receive the input signals from each respective channel of the mixer. If signals from two or more input channels are sent to a bus line, these signals are overlaid or mixed.

There is also a STEREO bus (L, R), an AUX bus (1,2), and a CUE bus.

Recorder

The signals from the bus lines are recorded by the cassette recorder. It also sends the signal to the TAPE OUT connectors and back to the mixer (including the CUE bus).

Also refer to the "Block Diagram" on page 48.

1 Controls and Connections

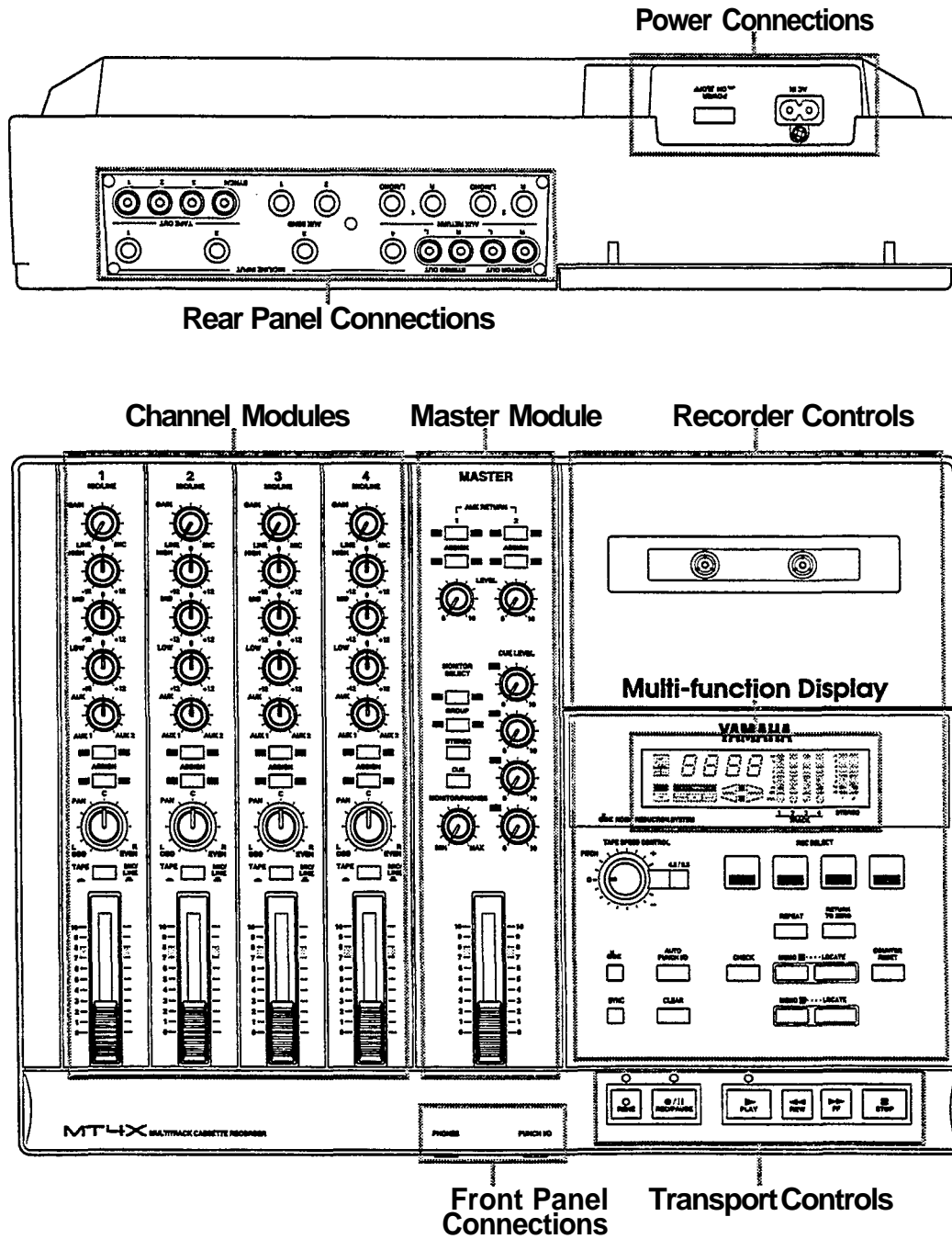

Channel Modules

① GAIN control

This rotary control adjusts the level of the signal from a microphone or instrument plugged into the MIC/LINE INPUT connector (④).

② Equalizer controls

These rotary controls are used to adjust the high, middle and low band frequency levels. To help you select the "flat" setting easily, each control has a centre-detent at the "0" position.

HIGH	±12 dB at 12kHz-shelving
MID	±12 dB at 1kHz-peaking
LOW	±12 dB at 80Hz-shelving

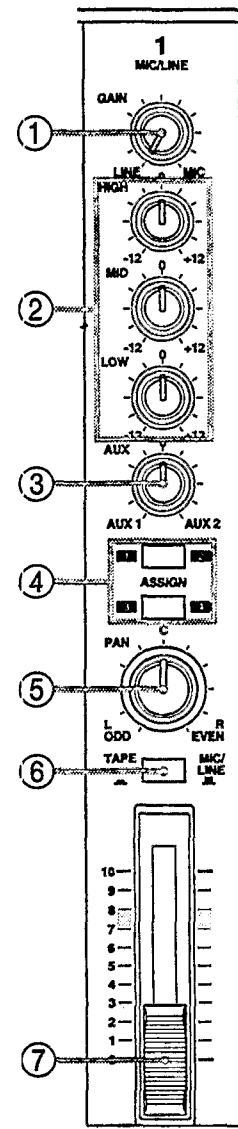
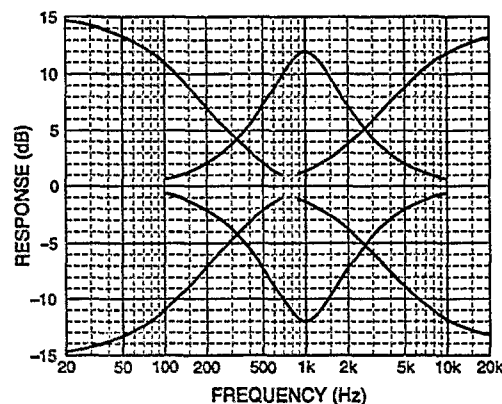

③ AUX controls

This rotary control is used to send the channel signal after the fader (⑦) to the auxiliary send buses. Rotated fully counter-clockwise sends the signal to the AUX 1 bus, fully clockwise to the AUX 2 bus. In the centre-detent "0" position, no signal is sent to either bus.

④ ASSIGN keys

These keys are used to select the group bus.

1-ASSIGN-2 selects the first track group - groups 1 and 2.

3-ASSIGN-4 selects the second track group - groups 3 and 4.

Use the PAN control (⑤) to select the individual track groups.

⑤ PAN control

This rotary control sets the stereo pan position of the channel signal. It is also used to select the individual track groups for recording.

ODD/L: Rotated fully counter-clockwise sends the signal to the odd (1 or 3) numbered track of the selected track group (ASSIGN keys ④) and to the left channel of the STEREO bus.

EVEN/R: Rotated fully clockwise sends the signal to the even (2 or 4) numbered track of the selected track group (ASSIGN keys) and to the right channel of the STEREO bus.

- ⑥ **Input select (TAPE - MIC/LINE) key**
This key selects the input source for the channel. Pressed in (.), it selects the tape track corresponding to the channel module (for example, the channel 1 key selects track 1). In the out position (.), the source is the MIC/LINE INPUT connector (④).
- ⑦ **Channel fader**
This linear control is used to set the channel level. For optimal performance and signal balance, the fader should be positioned between 7 and 8.

Master Module

- ⑧ **AUX RETURN-- ASSIGN keys**
These keys assign the signal from the AUX RETURN connectors (④) to the selected group bus.
- ⑨ **Auxiliary return LEVEL controls**
These rotary controls adjust the level of the auxiliary return signal.
- ⑩ **MONITOR SELECT keys**
These keys are used to select the group buses, the stereo bus, and the cue bus signals. The signals are routed to the MONITOR OUT (④) connectors on the rear panel and the stereo PHONES (④) connector on the front of the MT4X.

GROUP: These keys select groups 1 and 3 and groups 2 and 4 respectively. If you select both keys, groups 1 and 3 will be sent to the left channel and groups 2 and 4 will be sent to the right channel.

STEREO: This key selects the stereo bus signal.

CUE: This key selects the cue bus signals. These are the playback signals direct from the cassette tracks. When you are recording, the record signal is monitored.

- ⑪ **CUE LEVEL controls**
These rotary controls adjust the level of the signal from each track before it is sent to the cue bus.

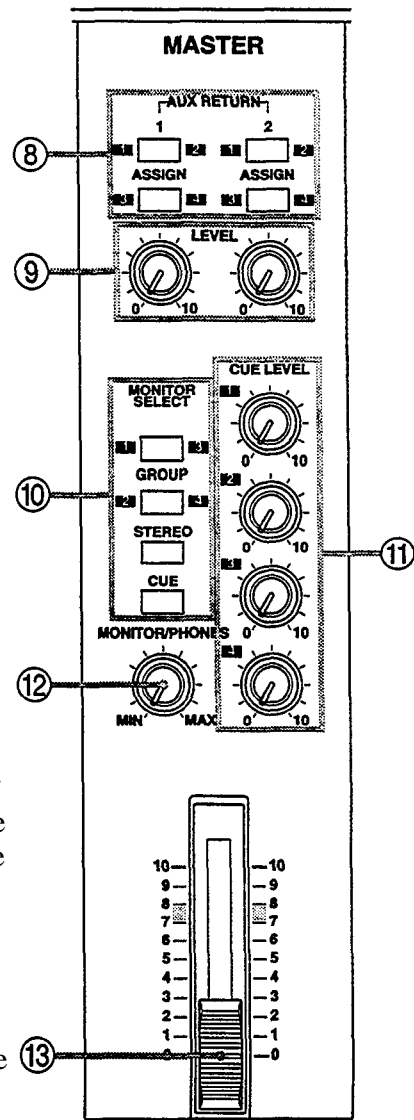

- ⑫ **MONITOR/PHONES level control**
This rotary control adjusts the volume level of the stereo PHONES (④④) connector and the MONITOR OUT (④⑤) connectors.
- ⑬ **Master fader**
This linear control is used to set the level of the master stereo bus. For optimal performance and signal balance, the fader should be positioned between 7 and 8.

Recorder Controls

- ⑭ **Cassette tape compartment**

- ⑮ **Multi-function display**
This FLD (Fluorescent Light Display) shows the operating modes and signal levels of the MT4X. See "Multi-function Display" on page 11.

- ⑯ **TAPE SPEED CONTROL**
These controls consist of a rotary PITCH control and a tape speed (4.8/9.5) select key.
The PITCH control can adjust the tape speed by approximately $\pm 10\%$.

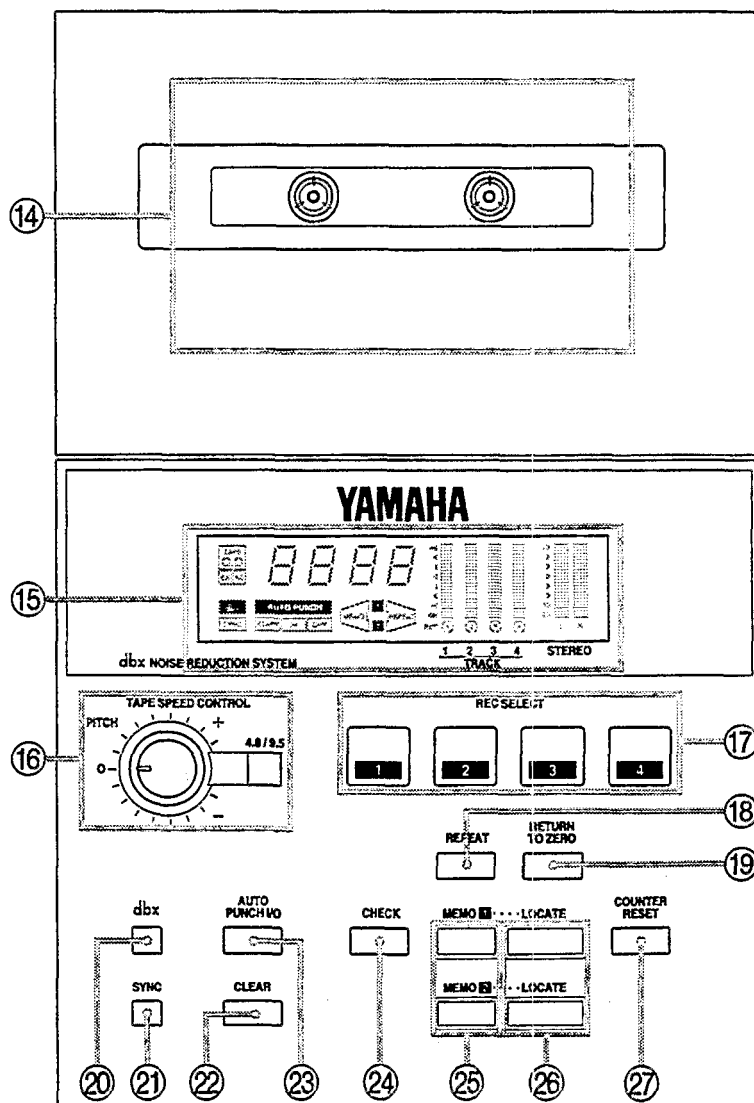

The tape speed (4.8/9.5) select key is used to switch the tape speed between 9.5 cm/sec and 4.8 cm/sec. 9.5 cm/sec will be selected automatically when the power is turned on.

Note: The tape speed cannot be changed while the tape transport is in motion. Press the STOP key (③③), then press the tape speed select key.

17 REC SELECT keys

These keys are used to arm the tracks for recording. When you press a REC SELECT key/the record select indicator (43) for the corresponding track flashes on the multi-function display (15).

18 REPEAT key

This key is used to start and cancel the repeat function. When the repeat function is active, the MT4X will repeatedly playback a selection between two memory points set with the MEMO keys (25). See "Repeat Function" on page 42.

When the automatic punch-in/out function is active, the REPEAT key causes the MT4X to immediately start the rehearsal mode. See "Using the automatic punch-in/out function" on page 21.

Note: *The repeat interval must be more than three counts on the tape counter (35).*

19 RETURN TO ZERO key

This key rewinds the tape to the point where the tape counter (35) reads "0000". The tape counter flashes while the tape rewinds.

20 dbx key

This key is used to turn the dbx noise reduction system on and off. By default, the dbx™ system is turned on when the MT4X is first powered on.

The dbx™ system has no effect on track 4 when the SYNC key (21) is on. See "FSK recording" on page 35.

21 SYNC key

This key defeats the dbx™ noise reduction system on track 4. This allows you to record FSK signals onto the track. See "FSK recording" on page 35.

22 CLEAR key

This key clears the stored memory points. When automatic punch-in/out is active (the AUTO PUNCH indicator (40) is illuminated), this key clears the current setting (but does not clear the memory points).

23 AUTO PUNCH I/O key

This key is used to start and cancel the automatic punch-in/out function. See "Using the automatic punch-in/out function" on page 21.

24 CHECK key

This key is used to verify the memory points. Press and hold this key and the press one of the MEMO keys (25). The corresponding MEMO indicator (41) will flash and the stored value will be shown on the tape counter (35).

25 MEMO (1, 2) keys

These keys store the current tape counter (35) value as memory points. When you press one of these keys, the corresponding MEMO indicator (41) will light and the point stored.

You can clear the memory points by pressing the CLEAR key (22), removing the cassette tape, or turning off the power.

26 LOCATE (1, 2) keys

These keys locate to the stored memory points. When you press one of these keys, the MT4X will fast forward or rewind to the corresponding memory point.

Note: *The locate interval must be more than three counts on the tape counter (35).*

27 COUNTER RESET key

This key resets the tape counter (35) to "0000".

Transport Controls

28 REHE key and indicator

This key is used to perform a recording rehearsal. While the LED indicator over the key is illuminated, you can simulate a recording session. This allows you to check recording levels or practice punch-in/out without actually recording.

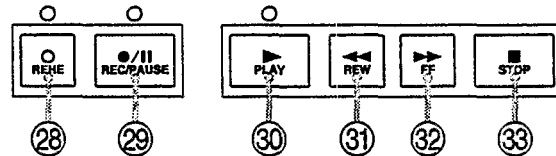

29 REC/PAUSE key and indicator

This key is used to record. Before you can actually record, you must arm the tracks with the REC SELECT keys (17). Press this key to place the MT4X in record standby mode. Once you press the PLAY key (30), recording will begin.

Press the key again to pause the recording.

30 PLAY key and indicator

31 REW key

This key is used to rewind the cassette tape.

32 FFkey

This key is used to fast forward the cassette tape.

33 STOP key

Multi-function Display

This section details the indicators of the FLD (Fluorescent Light Display) multi-function display (15).

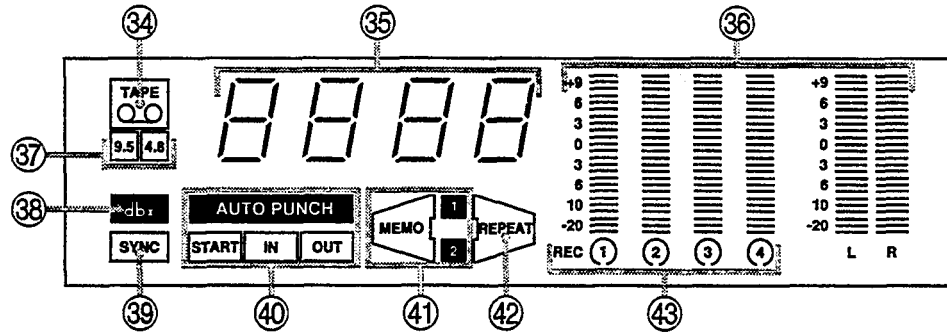

- 34 TAPE indicator**
This indicator illuminates when a cassette tape is inserted in the cassette tape compartment. If you press any of the transport keys before you have inserted a tape, the indicator will flash.

- 35 Tape counter**
This indicator displays tape position.

- 36 Level meters**
These indicators display the signal level within a range of -20 dB to +9 dB. The individual tracks and the stereo bus are displayed.

- When dbx™ is off, the normal signal limit is approximately 0 dB.
- When dbx™ is on, the normal signal limit is approximately +6 dB.

Note: The meters can be switched to peakhold. To switch peakhold on or off, press the COUNTER RESET key (27) while holding down the STOP key (33).

- 37 Tape speed indicator**
These indicators show the current tape speed selection, either 9.5 cm/sec. or 4.8 cm/sec. When the MT4X is first powered on, it defaults to 9.5 cm/sec.
- 38 dbx indicator**
This indicator illuminates when the dbx™ noise reduction system is turned on.
- 39 SYNC indicator**
This indicator illuminates when SYNC key (21) has been switched on.
- 40 AUTO PUNCH indicators**
These indicators show the status of the automatic punch-in/out function. See "Using the automatic punch-in/out function" on page 21.
- 41 MEMO indicators**
These indicators illuminate when their respective memory points have been set.

42 REPEAT indicator

This indicator illuminates while the repeat function is active.

43 REC SELECT - TRACK indicators

These indicators flash when you arm the corresponding trade by pressing one of the RECSELECT keys (17). The armed indicators switch from flashing to illuminated when you press the REC/PAUSE key (29).

Front Panel Connections

44 PHONES connector

This 1/4" phone connector is used for a pair of stereo headphones (8 Ω to 40 Ω).

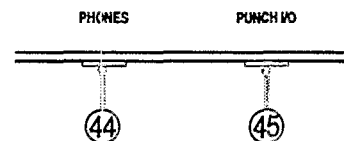

45 PUNCH I/O footswitch connector

This connector is used to plug in an optional footswitch (FC5) for punch-in/out recording. See "Using the optional footswitch" on page 28.

Rear Panel Connections

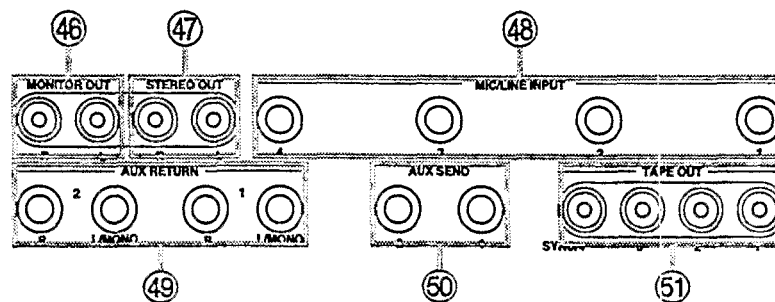

46 MONITOR OUT connections

- **Output impedance:** 1 k Ω
- **Nominal output level:** -10 dB (at 10 k Ω load)

These RCA/Phono connectors are used to plug in a monitor amplifier or powered loudspeakers. The same signal which is output from the PHONES connector (44) is also output from these connectors.

47 STEREO OUT connections

- **Output impedance:** 1 k Ω
- **Nominal output level:** -10 dB (at 10 k Ω load)

These RCA/Phono connectors are used to output the final stereo mixdown to the master recorder — typically, a stereo tape deck

48 MIC/LINE INPUT connections

- **Input impedance:** 10 k Ω
- **Nominal input level:** -10 dB to -50 dB

These 1/4" phone connectors are used to input microphones, electronic instruments, and line-level sources.

④9 AUX RETURN (1, 2) connections

- **Input impedance:** 10 k Ω
- **Nominal input level:** -10 dB (AUX RETURN-LEVEL control nominal)

These 1/4" phone connectors are used to input the signals from external effects devices and other signal processors. If the external device is monaural, plug it into one of the L/MONO connectors.

⑤0 AUX SEND (1, 2) connections

- **Output impedance:** 1 k Ω
- **Nominal output level:** -10 dB (at 10 k Ω load)

These 1/4" phone connectors are used to output signals to external effects devices and other signal processors.

⑤1 TAPE OUT (1 to 4/SYNC) connections

- **Output impedance:** 1 k Ω
- **Nominal output level:** -10 dB (at 10 k Ω load)

These RCA/Phono connectors are used to output the individual tracks directly from the recorder section of the MT4X.

Power Connections**⑤2 AC IN inlet**

Connect the supplied power cord here.

⑤3 POWER switch

This switch turns the power on and off.

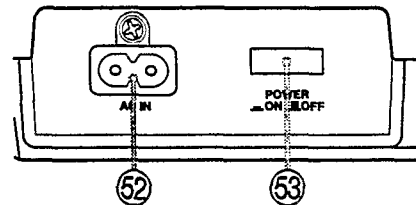

Note: Always make sure the Master fader (⑬) is set to "0" and the MONITOR/ PHONES level control is set to "MIN" when turning the MT4X on or off.

CAUTION (FOR CANADIAN MODEL)

TO PREVENT ELECTRIC SHOCK/ MATCH WIDE BLADE OF PLUG TO WIDE SLOT, FULLY INSERT.

2 Example System

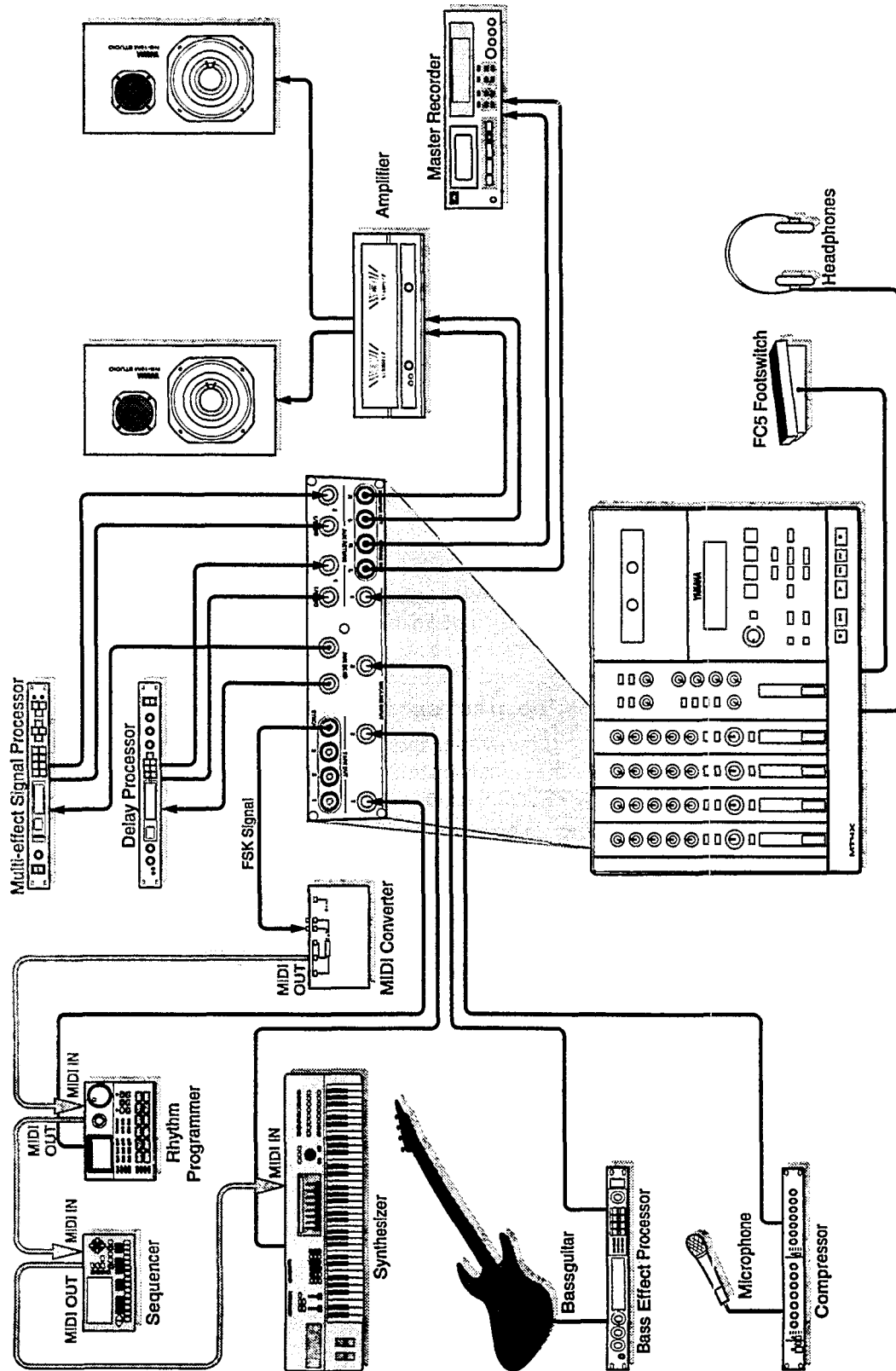

3 Recording Functions

The basic functions of multitrack recording are as follows:

Monitoring	Monitoring the recording or playback to listen for mistakes or unwanted distortion.
Initial recording	Recording the first instrument or part.
Overdub recording	Recording additional instruments or parts while monitoring the previously recorded tracks.
Punch-in/out recording	Correct mistakes or add short segments to an existing track.
Ping-pong recording	Bounce several existing tracks onto another track.
Mixdown	Mix the results of your multitrack recording onto a stereo master tape.

Monitoring

The MT4X offers you a great deal of flexibility in monitoring the status of your recordings. You can monitor the individual channel groups, the stereo bus, the cue bus, or any combination.

You control monitoring with the MONITOR SELECT keys :

- GROUP** The GROUP keys allow you to monitor the group bus signals. If you only press one key, you will hear monaural output. If you press both keys, you will hear groups 1 and 3 in the left channel and groups 2 and 4 in the right channel. The signals on the group buses go directly to the recorder.
- STEREO** The STEREO key allows you to monitor the stereo bus signal. You can monitor the signals from the four input channels as well as the AUX RETURN signal. Some of these signals may not have been assigned to the group bus, allowing you to listen to signals that will not be recorded.
- CUE** The CUE key allows you to monitor the playback signals directly from the cassette tracks. You can set the volume for each track with the CUE LEVEL controls. The cue bus is monaural. When you are recording, the record signal is monitored.

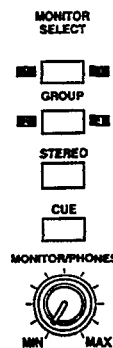

Of these three monitor sources, you will probably find the cue bus is the most useful. This bus allows you to monitor the previously recorded tracks as well as new material independently of the mixer section. It is sometimes very important to be able to listen directly to the tracks, for example, to compare different mixer settings to the original signal.

You adjust the overall monitoring level with the MONITOR/PHONES control.

Initial recording

The first step in multitrack recording is to record the initial tracks. Usually these are your rhythm tracks: bassguitar, rhythm guitar, and drums.

Note: Before you record anything, you must connect the MT4X to both an input source and a monitoring system. See "Example System" on page 14.

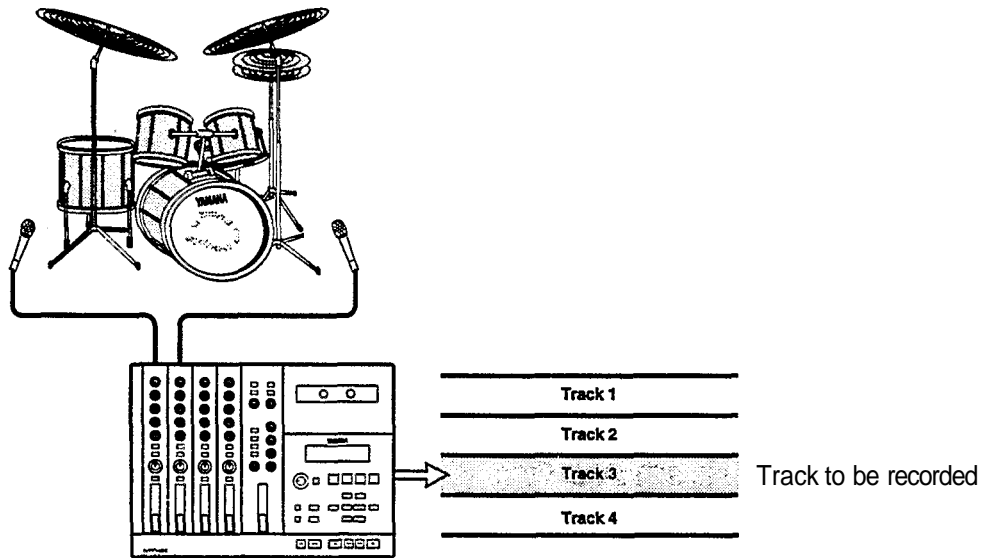

Preparations for recording



- 1) Insert a cassette tape into the cassette tape compartment (14).
- 2) Connect the input source to the corresponding MIC/LINE INPUT connector for each channel.
- 3) Set the input select key (6) to the MIC/LINE position.
- 4) Rotate the GAIN control (1) to adjust the initial level of the input signal.

If you have plugged a microphone into the corresponding connector, rotate the control fully clockwise to the MIC setting.

If you have plugged a synthesizer into the connector, or are running a bassguitar or guitar through a signal processor (line level output), rotate the control fully counter-clockwise to the LINE setting.

Note: This level setting is temporary — just to get a rough signal level based on the type of input you have connected. Be aware that you could easily be sending a signal that is overloading the gain amplifier and causing distortion. To set the final level, see steps 10 and 11.

- 5) Using the ASSIGN keys (④) and the PAN control (⑤) select the group bus you want the input signal to go to.

Press the  and rotate the PAN control:  The input signal is sent to the first (odd) group.

Press the  and rotate the PAN control:  The input signal is sent to the second (even) group.

Press the  and rotate the PAN control:  The input signal is sent to the third (odd) group.

Press the  and rotate the PAN control:  The input signal is sent to the fourth (even) group.

Group 1	->	Track 1
Group 2	->	Track 2
Group 3	->	Track 3
Group 4	->	Track 4

If the PAN control is set to a position partway between L/ODD and R/EVEN, the input signal will be sent to both the odd and even group buses.

If you press both ASSIGN keys, the input signal will be sent to at least two group buses.

- 6) Press the REC SELECT keys (⑰) for the tracks you want to record.

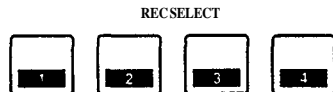

The corresponding REC SELECT - TRACK indicator (④③) on the display will flash.

Press the REC SELECT key again to cancel the selection.

- 7) Press the MONITOR SELECT-CUE key (⑩). Adjust the CUE LEVEL controls (⑪) for the selected tracks. Set the monitor volume with the MONITOR/PHONES level control (⑫).

Tip: You can ignore step 7 and use any monitor mode or combination that you are comfortable with. See "Monitoring" on page 15.

- 8) Press the COUNTER RESET key (⑳) to set the tape counter (㉓) to "0000".

Set the recording levels

In order to obtain the best possible sound quality, it is very important to set optimal recording levels. If you set the levels too low, you will be able to notice tape noise. If you set the levels too high, the tape will be saturated and distortion will result. Therefore, you should set the recording levels to the highest level before distortion sets in.

The MT4X is equipped with sensitive peak-hold level meters (36). You can monitor the level of the individual tracks and the stereo bus. Use the level meters in conjunction with the monitoring modes (see "Monitoring" on page 15) to set your recording levels.

Note: *The meters display a range of -20 dB to +9 dB. If the meters exceed the normal limit momentarily, this is usually perfectly acceptable. Cassette tape is reasonably forgiving of transients - and human hearing has difficulty detecting the minor distortion that results. Where you start getting audible problems is when the meters are constantly above the normal limit. You must lower the levels in order to maintain decent sound quality.*

- 9) Press the REC/PAUSE key (29).

The indicator above the key lights and any flashing REC SELECT - TRACK indicators will be illuminated.

- 10) Set the channel fader (7) to the nominal level between "7" and "8".

- 11) Adjust the GAIN control while watching the level meters.

- When dbx™ is off, adjust the gain control so that the +3 dB segment occasionally illuminates.
- When dbx™ is on, adjust the gain control so that the +9 dB segment occasionally illuminates.

Note: *The MT4X can recall and display the maximum recording levels obtained during a session. See "Recording Levels Function" on page 42.*

Record the track

- 12) Press the PLAY key (30).

The indicator above the key lights and the MT4X starts the tape. Start playing.

Tip: *If your song starts with drums, bass guitar, and guitars all on the first bar, you will need to record a count-in.*

- 13) When the track is complete, press the RETURN TO ZERO key (19) to stop and rewind the tape.

Tip: *You may want to use the STOP key (33) to stop the tape and mark a memory point. See "Memory Functions" on page 41.*

The indicators above the REC/PAUSE and PLAY keys switch off and the REC SELECT - TRACK indicators resume flashing.

Check the completed recording

Once the tape has rewound back to "0000" on the tape counter, you should check the recording.

- 14) Press the PLAY key to playback the tape.
- 15) If the recording needs to be redone, repeat the previous steps.
- If the problem with the recording was a musical error, press the REC/PAUSE key and repeat steps 12 to 14.
 - If the problem was due to incorrect recording levels or other engineering problems, adjust the parameters by repeating steps 4 to 14.
- 16) When you are finished with an instrument, you should set the channel fader to "0". You may even want to disconnect the input source.

Overdubbing

Overdub recording is the basis of all multi-track recording. It enables you to record additional instruments or parts track-by-track while listening to the previously recorded tracks.

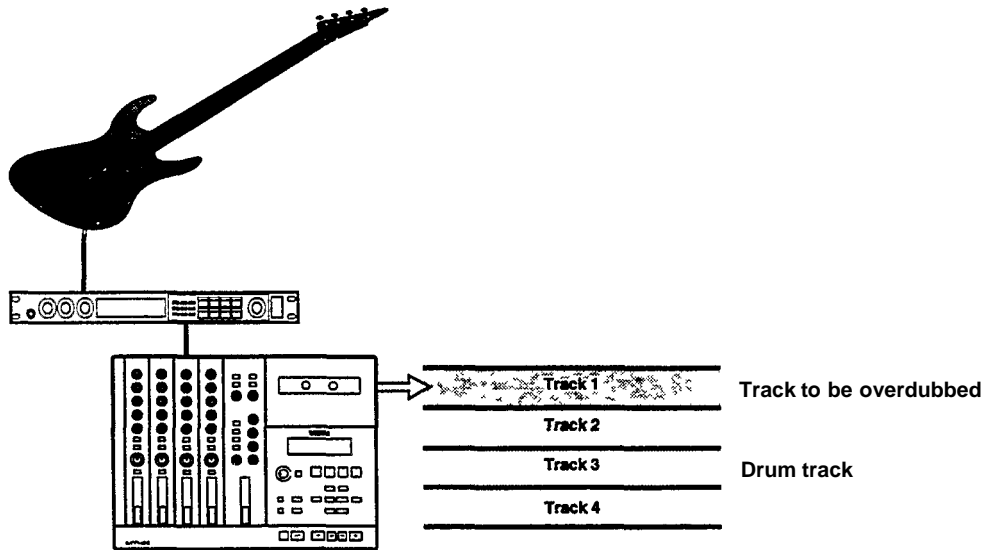

Preparations for recording

- 1) Connect the input source for each channel to the corresponding MIC/LINE INPUT connector.

Note: Connecting an instrument with a high output impedance such as an electric guitar or bassguitar to the MT4X may increase noise and distortion. If this happens, connect a direct box or effect unit between the instrument and the MT4X to reduce the impedance.

- 2) Set the input select key to the MIC/LINE position.
- 3) Rotate the GAIN control to adjust the level of the input signal.
- 4) Using the ASSIGN keys and the PAN control select the group bus you want the input signal to go to.
- 5) Press the REC SELECT keys for the tracks you want to record.
The corresponding REC SELECT - TRACK indicator on the display will flash.
- 6) Press the MONITOR SELECT-CUE key.
- 7) Press the PLAY key to playback the tape. As the tape plays, adjust the CUE LEVEL controls for the selected tracks. Set the monitor volume with the MONITOR/PHONES level control.
- 8) Press the RETURN TO ZERO key to rewind the tape back to "0000" on the tape counter.

Set the recording levels

- 9) Press the REHE key (Ⓜ).

The indicator above the key lights and any flashing REC SELECT - TRACK indicators will be illuminated.

- 10) Set the channel fader to the nominal level between "7" and "8" and adjust the GAIN controls.

Rehearsal

After you have set the recording levels, you should rehearse the overdub to verify and adjust the settings and cue levels.

- 11) Press the PLAY key to start the rehearsal.

The indicator above the key lights and the MT4X starts the tape. Start playing.

Tip: Sometimes the pitch of an instrument and the pitch of the previously recorded tracks is slightly different. If you cannot adjust the pitch of the instrument, you can compensate for the error with the TAPE SPEED CONTROL (16) - PITCH control. The PITCH control can adjust the tape speed by approximately $\pm 10\%$. During rehearsal, adjust the PITCH control until you have matched the instrument with the tracks.

- 12) Press the RETURN TO ZERO key to stop the rehearsal and rewind the tape.

The indicators above the REHE and PLAY keys switch off and the REC SELECT - TRACK indicators resume flashing.

Record the track

- 13) Press the REC/PAUSE key.

The indicator above the key lights and any flashing REC SELECT - TRACK indicators will be illuminated.

- 14) Press the PLAY key.

The indicator above the key lights and the MT4X starts the tape. Play the part again.

Note: To prevent wow and flutter effects, do not accidentally adjust the PITCH control while you are recording.

- 15) When the track is complete, press the RETURN TO ZERO key to stop and rewind the tape.

The indicators above the REC/PAUSE and PLAY keys switch off and the REC SELECT - TRACK indicators resume flashing.

Check the completed recording

- 16) Press the PLAY key to playback the tape and check the recording.
- 17) If the recording needs to be redone, repeat the previous steps.

To overdub another part, simply repeat steps 1 to 17.

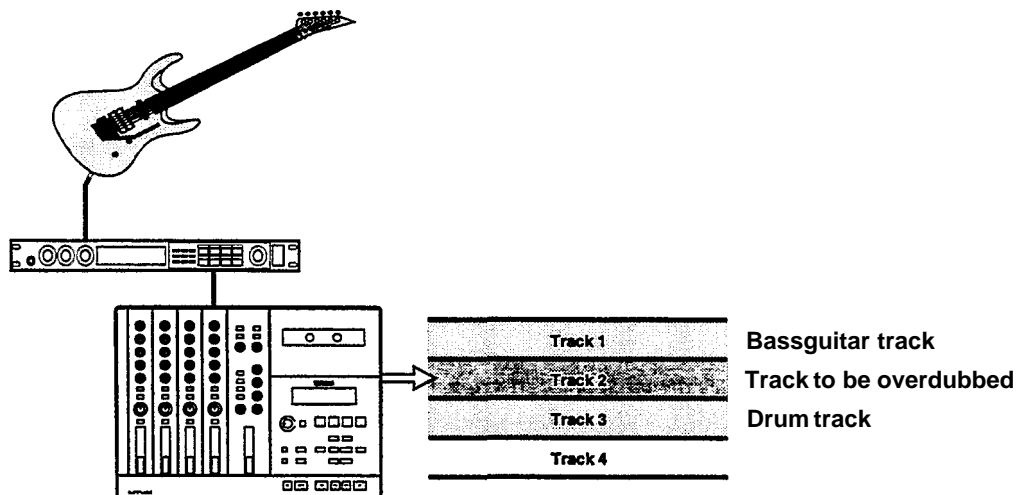

Punch-in/out recording

This technique is used to re-record short sections, correct mistakes, or add new sections to silent passages. You play your part while punching in and out to start and stop the recorder. For the greatest precision, you should use the advanced automatic punch-in/out features of the MT4X.

However, it is reasonably easy to punch-in manually. If you have a footswitch, you can also punch in and out using your foot. This keeps your hands free for making music.

Tip: You should ensure that the mixer and instrument settings are identical to the original recording. If you record a punch-in at a different volume level, for example, it will not blend into the previously-recorded track and your edit will be obvious. You will find keeping accurate track sheets invaluable to making invisible punch-in/out recordings. See "Tracking Sheet" on page 49.

There are three basic methods for punch-in/out recording:

- Using the automatic punch-in/out function.
- Using the REC/PAUSE key and the PLAY key.
- Using the optional footswitch.

Using the automatic punch-in/out function

With the automatic punch-in/out function, you specify the punch-in and punch-out locations. The operation is then carried out automatically. If you make a mistake, you can repeat the operation with precision.

- 1) Connect the input source, set the input select key, and adjust the GAIN control and channel fader so that the mixer setting is identical to the previous recording.

Note: If you are using an optional FC5 footswitch, plug it into the PUNCH I/O footswitch connector.

- 2) Press the REC SELECT key for the track you want to punch-in.

The REC SELECT-TRACK indicator on the display will flash.

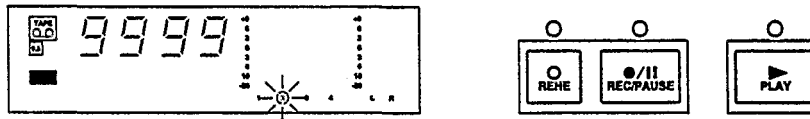

Note: You can skip step 2 at this point. However, you must select a track before you perform the actual recording.

Set the working points:

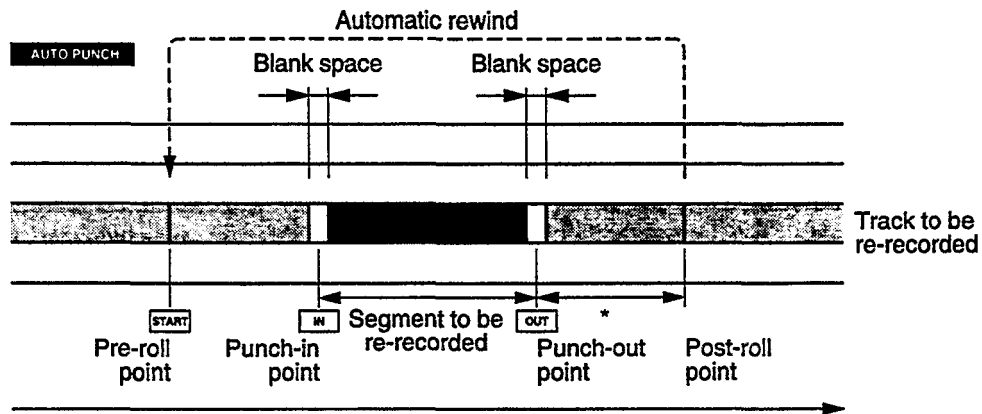

* Post-roll is 10 counts on the tape counter at 9.5 cm/sec (5 counts at 4.8 cm/sec).

Note: When you perform a punch-in/out recording, you need to find a blank section of about 1 second for your punch-in and punch-out locations. This is because of the gap between the erase head and record/playback head. Otherwise you may find that you have accidentally erased material that was before or after the re-recorded segment.

- The pre-roll point - the punch-in/out operation starts playback at this point to give you a count-in.
 - The punch-in point - recording begins.
 - The punch-out point - recording ends.
 - The post-roll point - the punch-in/out operation stops.
- 3) Fast-wind or rewind the tape to the location where you want to start the pre-roll. A location two or three measures before the punch-in point usually works well. Press the AUTO PUNCH I/O key (23) to mark the pre-roll point.

Note: If you press this key while a memory point is stored (either or both memory indicators (41) on the display are illuminated), the memory point data will be temporarily deleted and the indicator(s) switched off. When you cancel the Auto Punch function, the memory point data will be restored and the indicator(s) illuminated again. See "Memory Functions" on page 41.

The AUTO PUNCH and START indicators (40) on the display and the indicator above the REHE key will begin flashing.

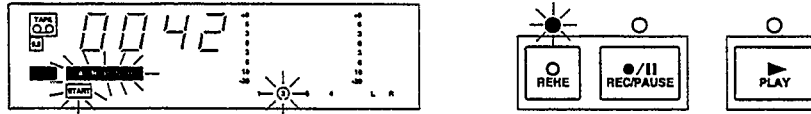

Note: The AUTO PUNCH indicator will either be flashing or illuminated while the automatic punch-in/out function is active.

- 4) Press the PLAY key (or step on the footswitch) to play the tape.

The START indicator will light and the IN indicator will begin flashing. The indicator above the REC/PAUSE key will flash rapidly.



Note: You can reverse the order of steps 3 and 4. In this case, you would mark the start point while playing by pressing the AUTO PUNCH I/O key.

- 5) At the punch-in location, press the REC/PAUSE key (or step on the footswitch).

The START indicator will switch off, the IN indicator will light, the OUT indicator will begin flashing, and the punch-in point will be stored. The indicator above the PLAY key will flash rapidly.

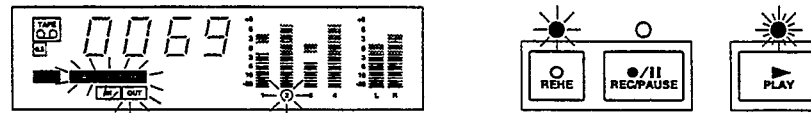

- 6) At the punch-out location, press the PLAY key (or step on the footswitch).

The IN indicator will switch off, the OUT indicator will light, and punch-out point will be stored.



Ten (10) counts on the tape counter (at 9.5 cm/sec - 5 counts at 4.8 cm/sec) after the punch-out location becomes the post-roll point. The OUT indicator will switch off, the START indicator will begin flashing, and the tape is automatically rewind back to the pre-roll point.

When tape is rewind, the AUTO PUNCH and START indicators will light and the indicator above the REHE key will flash rapidly.

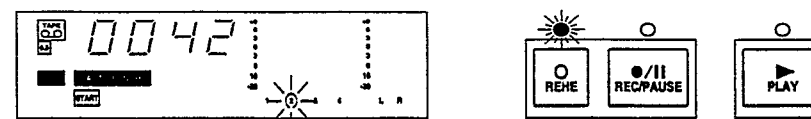

Rehearsal

The MT4X automatically enters rehearsal mode after you have assigned the punch-in and punch-out points. This mode allows you to practice the punch-in/out operation before you actually commit anything to tape.

Note: In this mode, you can press the REPEAT key (ⓑ) to start Repeat Rehearsal. The MT4X will automatically perform rehearsal playback between the pre-roll point and the post-roll point. For more detail, see "Repeat Function" on page 42.)

- 7) Press the MONITOR SELECT - CUE key. Adjust the CUE LEVEL controls for the selected tracks. Set the monitor volume with the MONITOR/PHONES level control.

- 8) Press the PLAY key (or step on the footswitch) to play the tape.

At the punch-in location, the START indicator will switch off, the IN indicator will light, and the indicator above the REHE key will light. If you are monitoring the cue bus, the sound will switch from the tape to the input source.

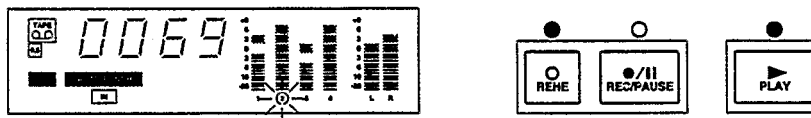

At the punch-out location, the IN indicator and indicator above the REHE key will switch off, the OUT indicator will light, and monitor source will switch back to the tape.



At the post-roll point, the OUT indicator will switch off, the START indicator will begin flashing, and the tape is automatically rewound back to the pre-roll point.

When tape is rewound, the AUTO PUNCH and START indicators will light and the indicator above the REHE key will flash rapidly.

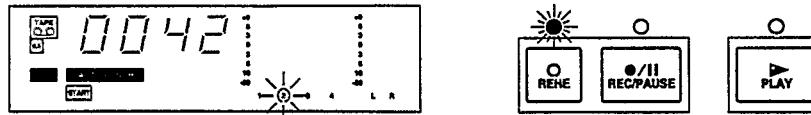

If you are satisfied with the working points, you can move on to the next operation, the actual recording. Otherwise, press the CLEAR key (Ⓒ) to clear the points and repeat steps 3 to 6.

Recording

- 9) Press the REC/PAUSE key.

The indicator above the REHE key will switch off and the indicator above the REC/PAUSE key will flash rapidly.

Note: If you skipped step 2, you need to use the REC SELECT key(s) to select a track (or tracks) before you record.

- 10) Press the PLAY key (or step on the footswitch) to play the tape. Get ready to play the punch-in part.

At the punch-in location, the START indicator will switch off, the IN indicator will light, and the indicator above the REC/PAUSE key and the REC SELECT - TRACK indicator will light.



Play the punch-in part.

At the punch-out location, the IN indicator and indicator above the REC/PAUSE key will switch off, the REC SELECT - TRACK indicator will flash, the OUT indicator will light, and monitor source will switch back to the tape.

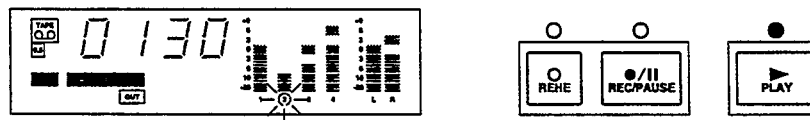

At the post-roll point, the OUT indicator will switch off, the START indicator will begin flashing, the indicator above the PLAY key will flash in a pattern (check waiting condition), and the tape is automatically rewound back to the pre-roll point.

When tape is rewound, the AUTOPUNCH and START indicators will light.

Check the recording

- 11) Press the PLAY key again to play back the tape.

The MT4X will automatically play from the pre-roll point to the post-roll point.

If the resulting recording is good, press the AUTO PUNCH I/O key to cancel the automatic punch-in/out function. The punch-in and punch-out points as well as the pre-roll and post-roll points are cleared. If you want to perform another automatic punch-in/out recording, you will have to start from step 3.

If the resulting recording is not good, press the REHE key and repeat from step 7.

If the pre-roll or post-roll points need to be changed, press the CLEAR key and repeat from step 3.

Status indicators

During the operation of the automatic punch-in/out function, you can determine the status by checking the indicators shown in the following table:

Function	Display Indicators					LEDs		
	AUTO PUNCH	START	IN	OUT	⊕	⊖	⊕/⊖ REWIND	▶ PLAY
Mark the pre-roll point (see step 3).			—	—			—	—
Start the tape playing (see step 4). If you press the AUTO PUNCH I/O key while the tape is playing, the operation starts here.				—				●
Mark the punch-in point (see step 5).		—					—	
Mark the punch-out point (see step 6).		—	—				—	●
The tape is rewind, waiting for rehearsal (also see step 6).			—	—			—	—
Rehearsal mode (see step 8).		—		—	⊕	●	—	●
		—	—			—	—	●
The tape is rewind, ready for recording (see step 9).			—	—		—		●
Recording mode (see step 10).		—		—	⊕	—	●	●
		—	—			—	—	●
While the tape is rewinding, the Play LED flashes the waiting pattern.			—	—		—	—	

Using the REC/PAUSE key and the PLAY key

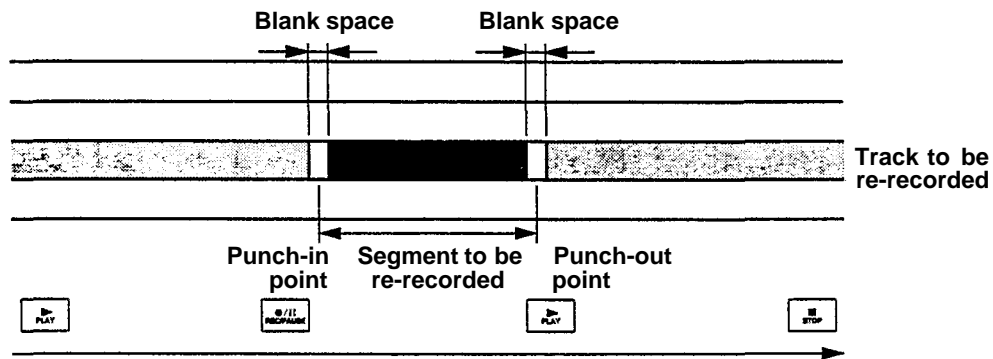

Note: When you perform a punch-in/out recording, you need to find a blank section of about 1 second for your punch-in and punch-out locations. This is because of the gap between the erase head and record/playback head. Otherwise you may find that you have accidentally erased material that was before or after the re-recorded segment.

- 1) Connect the input source, set the input select key, and adjust the GAIN control and channel fader so that the mixer setting is identical to the previous recording.
- 2) Press the REC SELECT key for the track you want to punch-in.
The REC SELECT - TRACK indicator on the display will flash.
- 3) Press the PLAY key.
The indicator above the key lights and the MT4X starts the tape. Get ready to play the punch-in part.
- 4) At the punch-in location, press the REC/PAUSE key.

Note: You can practice the punch-in at this point with the rehearsal function. Press the REHE key instead of the REC/PAUSE key.

The indicator above the key lights and the flashing REC SELECT - TRACK indicator will be illuminated. Play the punch-in part.

- 5) Press the PLAY key at the punch-out location.
The indicator above the REC/PAUSE key switches off and the REC SELECT - TRACK indicator resumes flashing.
You could also use the STOP key or the RETURN TO ZERO key at this point.

Using the optional footswitch

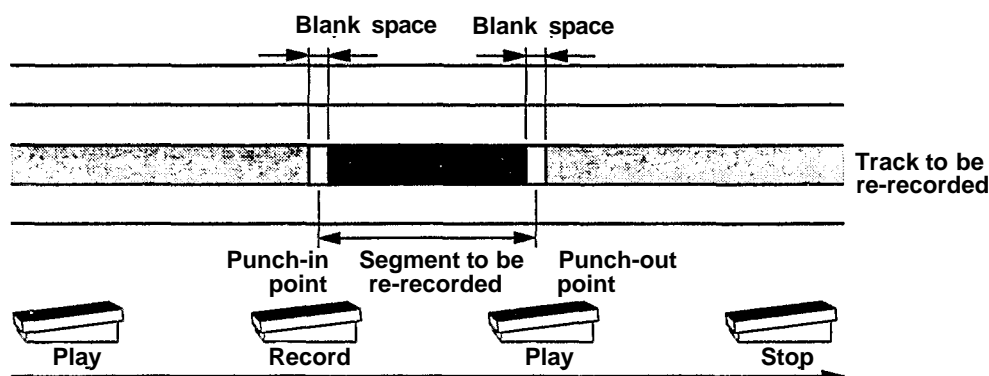

Note: When you perform a punch-in/out recording, you need to find a blank section of about 1 second for your punch-in and punch-out locations. This is because of the gap between the erase head and record/playback head. Otherwise you may find that you have accidentally erased material that was before or after the re-recorded segment.

- 1) Connect the input source, set the input select key, and adjust the GAIN control and channel fader so that the mixer setting is identical to the previous recording.
- 2) Plug an optional FC5 footswitch into the PUNCH I/O footswitch connector (45).

Note: Yamaha supplies an optional footswitch, FC5. Using another manufacturer's footswitch may cause mis-timing. See your Yamaha dealer for details.

- 3) Press the REC SELECT key for the track you want to punch-in.
The REC SELECT - TRACK indicator on the display will flash.
- 4) Press the REC/PAUSE key.

Note: You can practice the punch-in at this point with the rehearsal function. Press the REHE key instead of the REC/PAUSE key.

The indicator above the key lights and the flashing REC SELECT - TRACK indicator will be illuminated.

- 5) Step on the footswitch.
The indicator above the PLAY key lights, the indicator above the REC/PAUSE key will flash rapidly, and the MT4X starts the tape. Get ready to play the punch-in part.
- 6) At the punch-in location, step on the footswitch again.
The indicator above the REC/PAUSE key lights. Play the punch-in part.
- 7) Step on the footswitch at the punch-out location.
The indicator above the REC/PAUSE key switches off.

Ping-pong recording

Ping-pong recording allows you to bounce several previously-recorded tracks onto an unrecorded track. Using this technique, you can create a recording with effectively more than four tracks.

There are two basic techniques you can employ when making a bounce-down recording:

- Mixing three previously-recorded tracks onto a destination track.
- Overdubbing a new sound source during a ping-pong recording.

Bouncing tracks

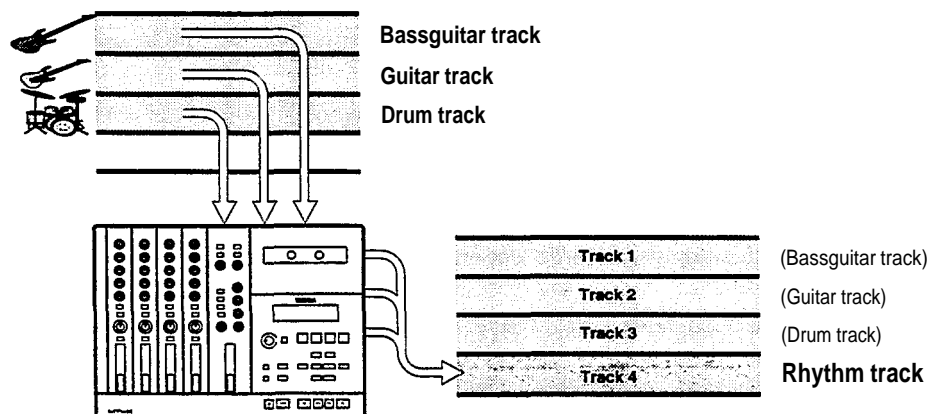

Preparation for recording

- 1) Fast-wind or rewind the tape to the beginning of your recording. Press the COUNTER RESET key to set the tape counter to "0000".
- 2) Set the input select keys to the TAPE position for the source tracks.
- 3) On each of the source tracks, use the ASSIGN keys and the PAN control to select the group bus for the destination track.
- 4) Press the REC SELECT key for the destination track.
The corresponding REC SELECT - TRACK indicator on the display will flash.
- 5) Press the MONITOR SELECT - GROUP key corresponding to the destination track.

Rehearsal

- 6) Press the REHE key.
The indicator over the key lights and the flashing REC SELECT - TRACK indicators will be illuminated.
- 7) Press the PLAY key to start the rehearsal.
The indicator above the key lights and the MT4X starts the tape.
- 8) Adjust the channel fader, PAN controls, and equalizer controls for each source channel.

If required, add effects using the AUX SEND and AUX RETURN controls and connectors. Adjust the effects for each channel.

Note: *You cannot apply effects to the individual tracks nor can you adjust the sound balance once you have mixed them onto a single track. You must apply any effects, and adjust the equalization and balance, during the bounce-down recording.*

- 9) Press the RETURN TO ZERO key to stop and rewind the tape.

Recording

- 10) Press the REC/PAUSE key.

The indicator over the key lights and the REC SELECT - TRACK indicators will be illuminated.

- 11) Press the PLAY key to start recording.

The indicator above the key lights and the MT4X starts the tape.

- 12) When the recording is finished, press the RETURN TO ZERO key to stop and rewind the tape.

The indicators over the REC/PAUSE and PLAY keys switch off and the REC SELECT - TRACK indicators resume flashing.

Check the recording

- 13) Release the MONITOR SELECT - GROUP key corresponding to the destination track and press the CUE key.
- 14) Adjust the CUE LEVEL control of the newly-recorded destination track.
- 15) Press the PLAY key to start playback of the tape.

If the resulting recording needs to be redone, repeat from step 6.

Overdubbing/ping-pong recording

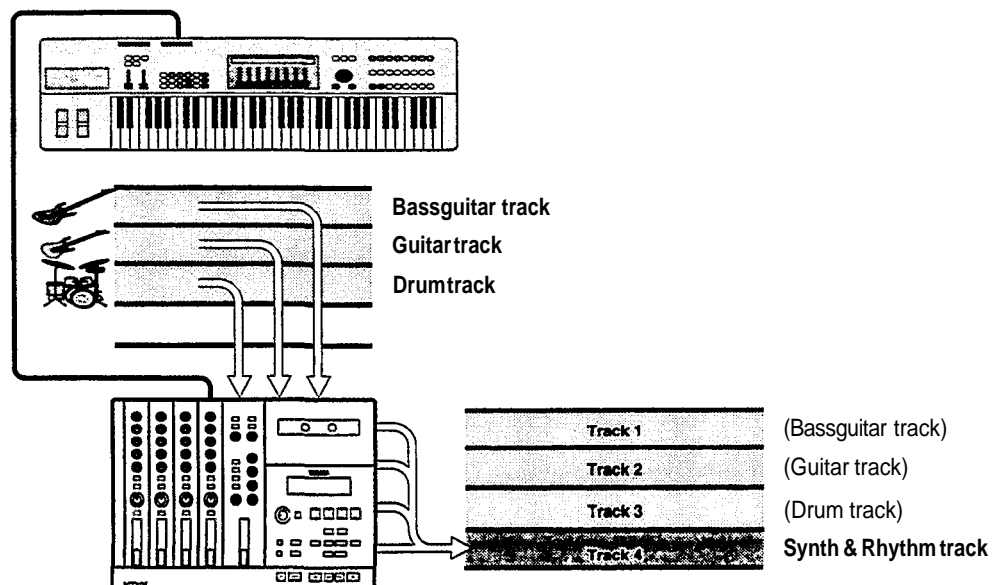

This technique is a combination of overdubbing (see "Overdub recording" on page 15) and ping-pong recording.

- 1) Connect the input source for the overdubbing channel to its corresponding MIC/LINE INPUT connector.
- 2) Set the input select key to the MIC/LINE position.
- 3) Rotate the GAIN control to adjust the level of the input signal.
- 4) Use the ASSIGN keys and the PAN control to select the group bus for the destination track.
- 5) Set up the source tracks as listed in the previous section ("Preparation for recording" on page 29).
- 6) Press the REHE and PLAY keys to rehearse the overdub/ping-pong.
Play along with the tape. Adjust the channel fader, PAN controls, and equalizer controls for each source and input channel.
- 7) Press the RETURN TO ZERO key to stop and rewind the tape.
- 8) Press the REC/PAUSE and PLAY keys to start recording. When the recording is finished, press the RETURN TO ZERO key to stop and rewind the tape.
- 9) Check the recording.

Ping-pong notes

- Avoid ping-pong recordings to an adjacent track (for example, avoid bouncing track 2 to track 1 or track 3) as much as possible. Otherwise, crosstalk (the signal leak at the record/playback head) may cause feedback.
- If you must ping-pong to an adjacent track, set your recording levels carefully. Set the tape speed to 9.5 cm/sec for the highest quality sound. Do not boost the HIGH equalizer control too much. You should also use the dbx™ noise reduction system to avoid feedback and control noise levels.
- Unfortunately, sound quality will deteriorate rapidly if you overuse the ping-pong recording technique. You should try to plan out your multitrack recording to minimize the amount of bouncing that you need to perform. Remember, *Sgt. Pepper's Lonely Hearts Club Band* by the Beatles, was recorded on a four-track system!

Mixdown

Mixdown is the process of combining the four individual tracks into a final stereo mix. You blend and polish the sounds before you record them onto a stereo cassette recorder or DAT recorder.

The mix is created using the various mixer controls. You adjust the track levels with the channel faders, change the equalizations, and modify the stereo image with the pan controls. You can also connect external signal processors, such as a reverberator or digital delay, to further refine your mix.

Connections and setup

In these instructions, the MT4X is your *multitrack recorder* and the stereo cassette recorder or DAT recorder is the *master recorder*.

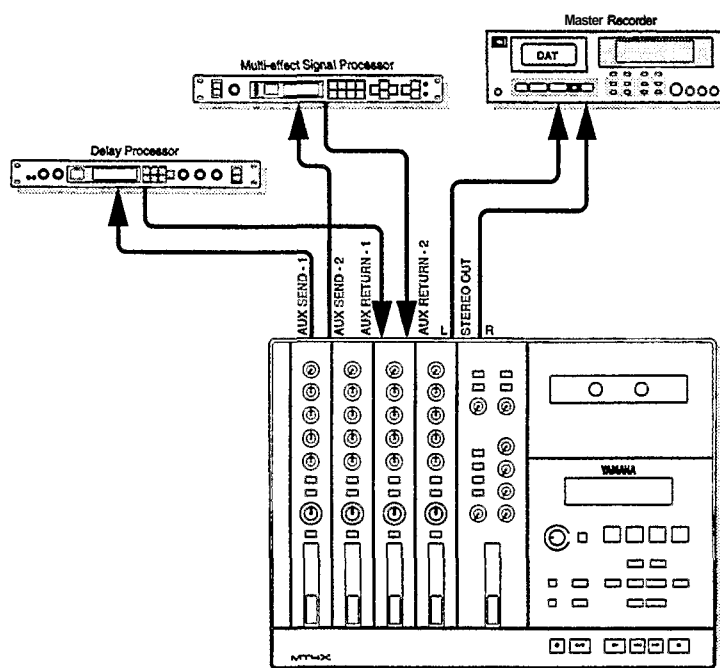

- 1) Using compatible cables, plug the stereo inputs of the master recorder into the STEREO OUT connectors (47).
- 2) Connect any external signal processors to the MT4X. Plug a compatible cable from the AUX SEND connector (50) into the input connector on the effect unit. Plug the output from the effect unit into the AUX RETURN connectors (49).

Note: If the effect unit has stereo outputs, connect it to the MT4X in stereo. Otherwise, plug it into the L/MONO connector.

Note: The MT4X has two auxiliary (AUX SEND and AUX RETURN) channels.

For an alternative setup, you can connect an external effects unit in between the MT4X (STEREO OUT connectors) and your master recorder.

- 3) Set the input select keys to the TAPE position for the individual tracks.
- 4) Press the MONITOR SELECT - STEREO key (10). Set the master fader to the nominal level between "7" and "8".

Rehearsal

- 5) Press the PLAY key to start playback.
- 6) Adjust the channel levels with the channel faders. Set the equalization with the HIGH, MID, and LOW equalizer controls (②). Use the Pan control to adjust the pan position. Set the aux send level with the AUX SEND controls (③). Adjust the auxiliary return levels with the LEVEL controls (⑨).

Set the levels and other parameters of any connected signal processing equipment.

Adjust the record levels on the master recorder.
- 7) When you are satisfied with the levels, press the RETURN TO ZERO key to stop the rehearsal and rewind the tape.

Recording

- 8) Insert a tape into the master recorder.
- 9) Start recording on the master recorder. Press the PLAY key on the MT4X to start playback.

Note: *You may want to remove any count-ins before you create your master tape. There are several ways of doing this. One method is to switch (input select key) the track that contains the count-in to the MIC/LINE position until the count is completed and then switch it to the TAPE. Another method is to set the MT4X to start playback after the count-in. Use the method that you find most comfortable.*

Check the recording

- 10) When the recording is finished, rewind the master recorder and play back the tape.

Tip: *You can add a synchronized MIDI part to your mix. See "Synchronized mixdown" on page 39.*

4 Synchronization

The MT4X has the ability to synchronize MIDI sequencers, rhythm programmers, and other devices to the existing tracks on your tape. The following section describes some of the advanced techniques you can employ.

When you create an overdub recording, you play along with the previously recorded tracks - matching the tempo. This is easy for a guitarist, vocalist, or keyboard player, but not so easy for a MIDI sequencer or rhythm machine. To synchronize MIDI instruments, you need to provide a timecode signal that the MIDI instrument can follow. This involves recording MIDI timecode onto a track using a technique called FSK (Frequency Shift Keying). Typically, the best time to do this is when you are laying down your basic tracks using a MIDI sequencer or rhythm machine to set the tempo.

Some MIDI sequencers and rhythm machines are already equipped with a SYNC OUT connector. You can plug this type of machine directly into the MT4X to record FSK onto one of the tracks.

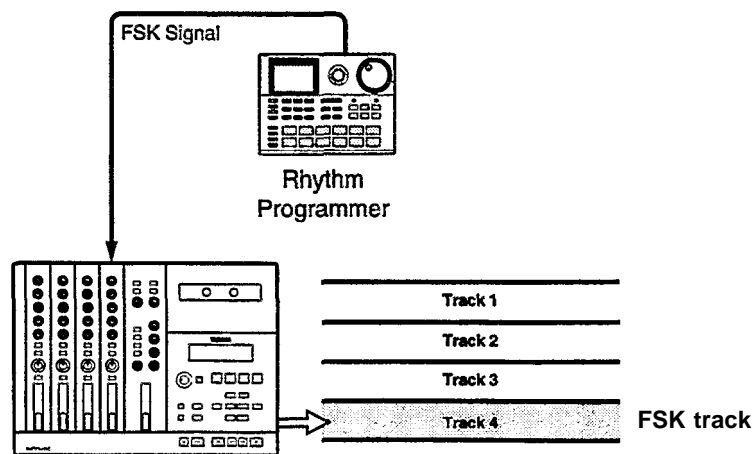

If your MIDI sequencer or rhythm machine is not equipped with a SYNC OUT connector, you may need a MIDI/FSK converter such as the Yamaha YMC10. You plug the MIDI/FSK converter in between your MIDI sequencer or rhythm machine and the MT4X to record FSK onto one of the tracks.

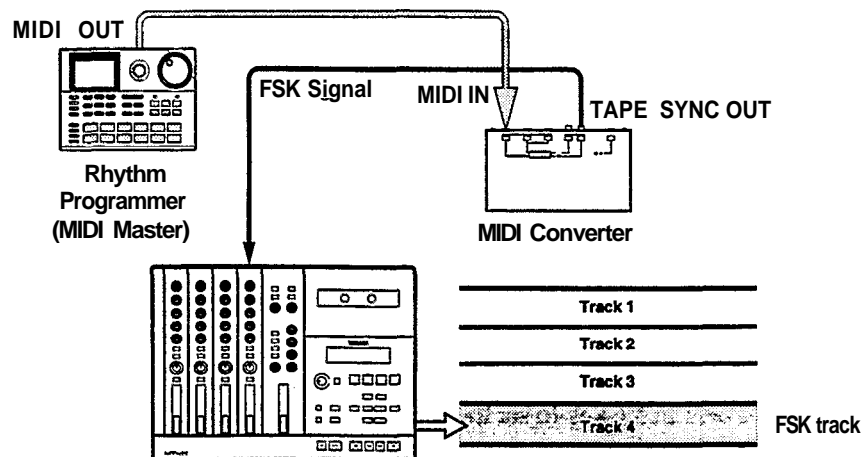



Please refer to the user's manual supplied with your MIDI instrument to see if it can output compatible FSK signals.

FSK recording

Record FSK signals on track 4

The MT4X is equipped with a dbx™ noise reduction system. For recording normal audio signals, the noise reduction system is beneficial. However, dbx™ interferes with the recording of FSK signals. This sometimes results in an unusable sync track. Therefore, the MT4X is also equipped with a SYNC key. When you press the SYNC key, the dbx™ system is defeated on track 4, allowing you to have noise reduction on your audio tracks and a usable sync track.

Connections and setup

- 1) Connect the MIDI/FSK output from your sequencer, rhythm machine, or converter to one of the MIC/LINE INPUT connectors.
- 2) Set the input select key for the corresponding channel to the MIC/LINE position.
- 3) Rotate the GAIN control fully counter-clockwise to the LINE setting.
- 4) Set the equalizer controls to the "0" (flat) position.
- 5) Press the  and rotate the  fully clockwise to select the fourth ASSIGN key: PAN control: (even) group - track 4.
- 6) Set the channel fader to the nominal level between "7" and "8".
- 7) Press the REC SELECT key for track 4.
The REC SELECT - TRACK indicator on the display will flash.
- 8) If dbx™ system is on, press the SYNC key (21).
The SYNC indicator (39) on the display will light.
- 9) If you are going to record audio signals from the MIDI instrument along with the FSK signal, connect the audio outputs to the channel connectors and set the mixer channels. See "Initial recording" on page 15.

Rehearsal

- 10) Press the REHE key to put the MT4X into rehearsal mode.
- 11) Start the MIDI instrument and adjust the recording levels.
Adjust the level of the FSK signals so that the level meters indicate about +6 dB.
- 12) Adjust the monitoring levels.
- 13) Stop the MIDI instrument.

Record the sync track

Note: These instructions assume you have recorded a song on your MIDI sequencer or rhythm machine that consists of a song start, tempo, and a song end. If you programmed tempo changes, these will also be recorded on the FSK track.

- 14) Fast-wind or rewind the tape to the beginning of your recording. Press the COUNTER RESET key to set the tape counter to "0000".
- 15) Press the REC/PAUSE and PLAY keys to start recording.
- 16) Start the MIDI instrument.

Run the song program on the MIDI instrument from beginning to end. The Song Start, Tempo (and tempo changes), and Song End are recorded onto the FSK track.

- 17) When the MIDI program has completed, stop the MIDI instrument and press the RETURN TO ZERO key to stop and rewind the tape.

Synchronized playback

Overdubbing with a synchronized performance

If your MIDI sequencer or rhythm machine cannot accept FSK signals, you may need a MIDI/FSK converter such as the Yamaha YMC10. You need to plug the MIDI/FSK converter in between the MT4X and your MIDI instrument.

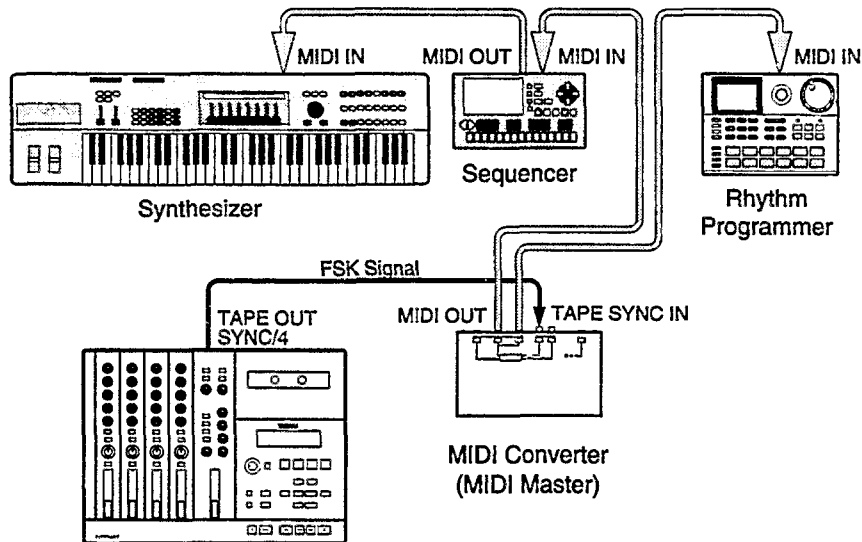

Some MIDI sequencers and rhythm machines can read FSK signals. You can plug this type of machine directly to the MT4X to synchronize to the recorded FSK signal.

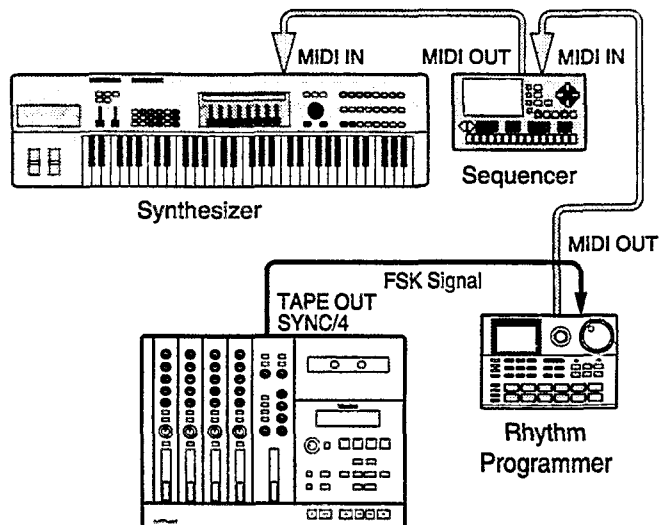

Connections and setup

- 1) Plug a compatible cable from the TAPE OUT - SYNC/4 (5) connector into the MIDI/FSK input on your sequencer, rhythm machine, or converter.

Set the connected MIDI instrument to FSK sync mode, to receive the FSK signals from the MT4X. Set any other connected MIDI instruments to MIDI clock mode to slave to the MIDI device receiving the FSK signals. Perform any other required setup on your MIDI instruments to ensure they perform correctly once the MT4X starts playing the FSK signals.

Please refer to the instruction manual supplied with your MIDI instrument for further setup details.

- 2) Connect your MIDI instrument(s) to a monitor mixer. Then connect the input source for each channel to the corresponding MIC/LINE INPUT connector.

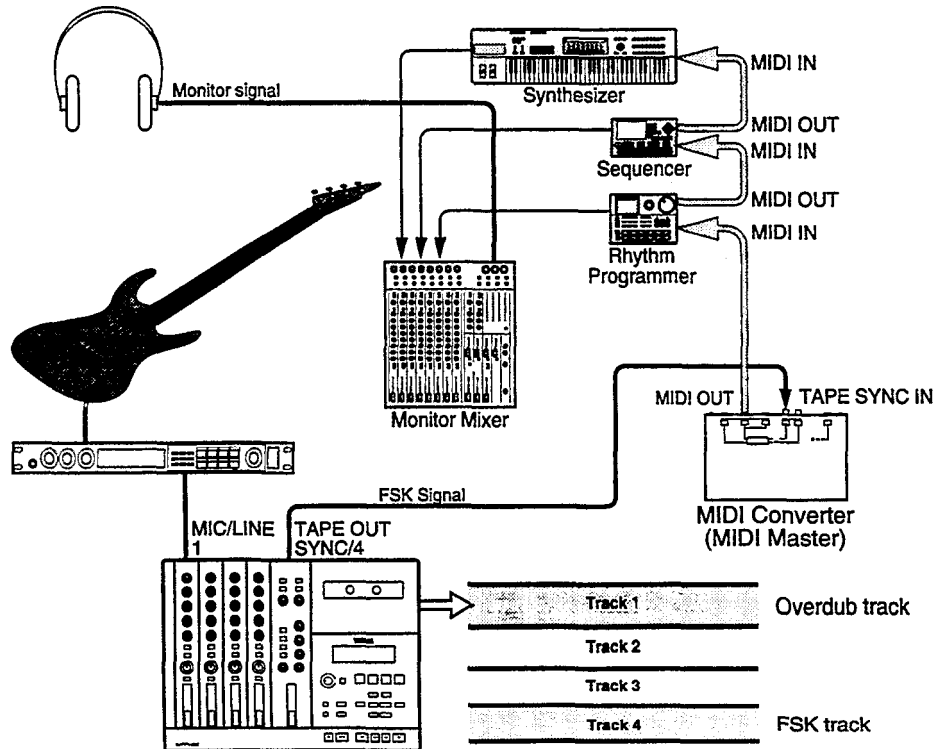

Adjust the input and monitor levels. See "Overdubbing" on page 19.

Tip: You may find it easier to have just one monitor channel to adjust. Plug a cable between the MONITOR OUT connectors and the input channels of the monitor mixer.

- 3) Press the REC SELECT keys for the tracks you want to record.
The corresponding REC SELECT - TRACK indicator on the display will flash.
- 4) If dbx™ system is on, press the SYNC key. The SYNC indicator will light.

Rehearsal

- 5) Press the REHE key to put the MT4X into rehearsal mode.
- 6) Press the PLAY key to start playback.

The MIDI instrument(s) will playback in sync with the data recorded on track 4.

Note: If the MIDI instrument does not play correctly, you probably started the tape at a point after the FSK signal began. You must ensure the tape plays back from before the start of the FSK track.

Play the overdub part along with the MIDI instrument(s) and the previously recorded tracks.

- 7) Adjust the recording and monitoring levels while watching the level meters.
- 8) When you are satisfied with the levels, press the RETURN TO ZERO key to stop the rehearsal and rewind the tape.

Recording

- 9) Press the REC/PAUSE and PLAY keys to start recording.
The MIDI instrument(s) will play automatically. Play the overdub part again.
- 10) When the recording is complete, press the RETURN TO ZERO key to stop and rewind the tape.

Check the recording

- 11) Press the PLAY key to start playback of the tape.
If the resulting recording needs to be redone, repeat from step 5.

Recording a synchronized performance

You may want to record your MIDI instrument(s) while they are synchronized with the FSK signal recorded on track 4. The procedure is similar to the previous section (see "Overdubbing with a synchronized performance" on page 36).

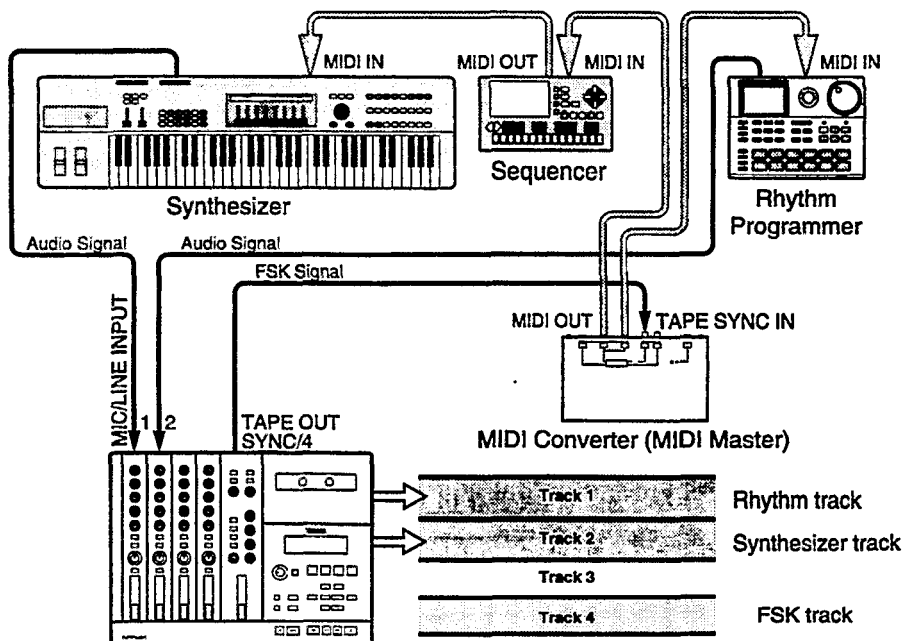

Synchronized mixdown

You can use the FSK signal to synchronize MIDI instruments to the previously recorded tracks on the MT4X while you are creating a mixdown recording (see "Mixdown" on page 32).

One of the advantages of this technique is that you can add multiple instruments to your mix without having to bounce-down tracks. To take full advantage of this technique, you may have to use an external mixer.

Tip: A special feature of the MT4X is its TAPE OUT connectors. These allow you to send the track signals directly from the recorder to your external mixer.

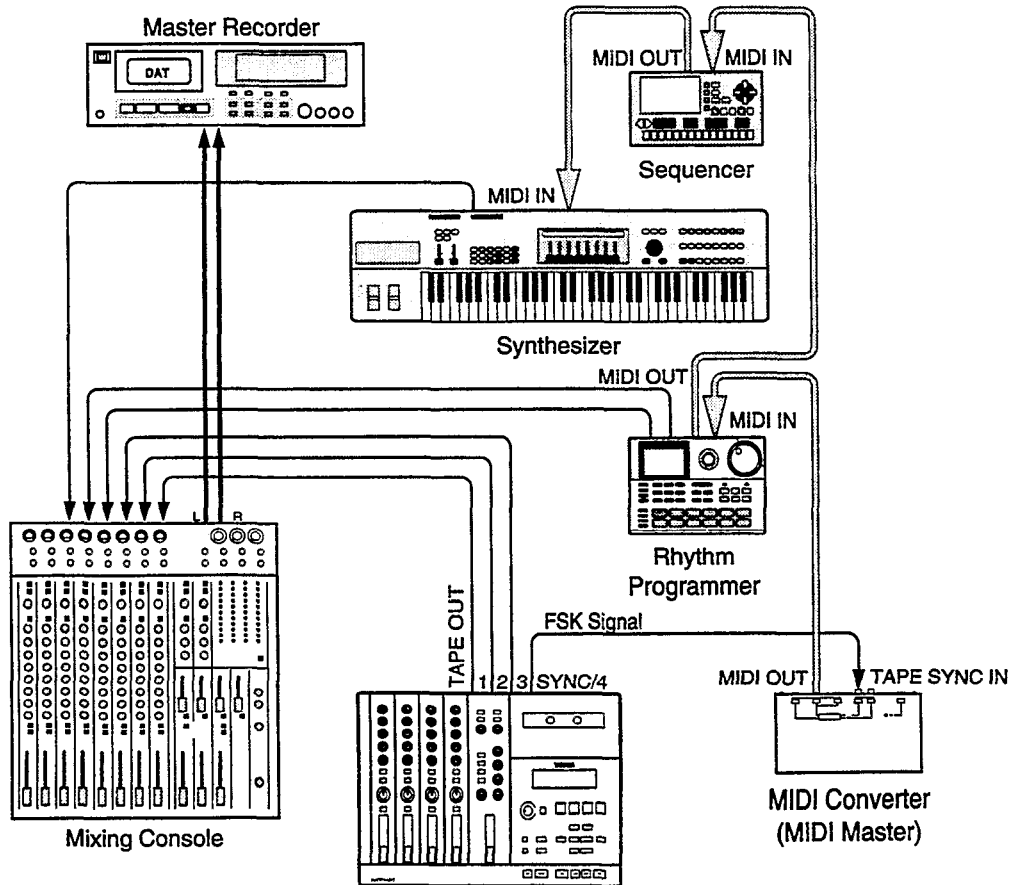

Connections and setup

- 1) Plug a compatible cable from the TAPE OUT - SYNC/4 (51) connector into the MIDI/FSK input on your sequencer, rhythm machine, or converter.
Set the connected MIDI instrument to receive the FSK signals from the MT4X.
- 2) Set any other connected MIDI instruments to MIDI clock mode to slave to the MIDI device receiving the FSK signals. Perform any other required setup on your MIDI instruments to ensure they perform correctly once the MT4X starts playing the FSK timecode.
Please refer to the instruction manual supplied with your MIDI instrument for further setup details.

- 3) Plug compatible cables from the other TAPE OUT connectors (1, 2, and 3) into the inputs of your mixer.

Tip: *An alternative approach is to create a stereo mixdown with the built-in mixer and send that to the external mixer from the STEREO OUT connectors.*

- 4) Connect the audio outputs from the MIDI instruments to the mixer inputs.
- 5) Connect the stereo inputs of the master recorder to the stereo outputs of the mixer.
- 6) Connect any external signal processors to the auxiliary connectors of the mixer.

Rehearsal

- 7) If dbx™ system is on, press the SYNC key. The SYNC indicator will light.
- 8) Press the PLAY key to start playback.
The MIDI instruments will start to playback in sync with the data recorded on track 4.
- 9) Adjust the levels, equalization, and pan of each channel on the mixer. Set the auxiliary send and return.
Adjust the record levels on the master recorder.
- 10) When you are satisfied with the levels, press the RETURN TO ZERO key to stop the rehearsal and rewind the tape.

Recording

- 11) Insert a tape into the master recorder.
- 12) Start recording on the master recorder. Press the PLAY key on the MT4X to start playback.
The synchronized mixdown will be carried out automatically.

Check the recording

- 13) When the recording is finished, rewind the master recorder and play back the tape.

5 Memory Functions

Memo Function

Store a memory location

You can mark two memory locations which can be used to quickly return to a specific point on your tape.

- 1) Fast-wind or rewind the tape to the location you want stored.

For example, you can locate the end of a track just by stopping the tape.

- 2) Press the MEMO-1 or MEMO-2 key (25).

The corresponding MEMO indicator (41) will flash three times and then light.

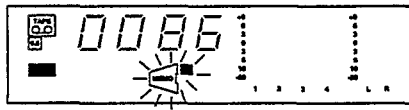

Check the memory locations

- 1) Press and hold the CHECK key (24).
- 2) Press the appropriate MEMO key.

The tape counter (35) will display the corresponding memory point value. The number portion to the MEMO indicator will flash for as long as the two keys are pressed.

The following display shows the MEMO-2 location being checked.

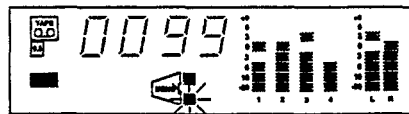

Locate to a stored location

- 1) Press the appropriate LOCATE key (26).

The MT4X will fast-wind or rewind the tape to the stored location. While the tape is in motion, the number portion of the MEMO indicator will flash.

The following display shows the results of pressing the LOCATE-2 key.

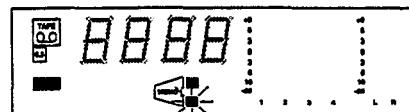

Note: The locate interval must be more than three counts on the tape counter.

If you reset the tape counter, the MT4X will re-calculate the stored memory locations. When you check a memory location, the value displayed will reflect the reset tape counter. When you locate to a memory location, the MT4X will fast-wind or rewind to the correct location.

Repeat Function

The MT4X will repeatedly play a section of the tape between two memory locations.

- 1) Press the REPEAT key (18).

The MT4X will fast-wind or rewind the tape to the first memory location. While the tape transport is in fast-wind or rewind mode, the REPEAT indicator (42) will flash on the display.

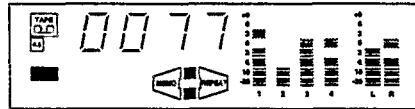

- 2) As soon as the MT4X has reached the first memory location, playback is started. The REPEAT indicator is illuminated.

Repeat notes

- If only one memory location is stored, the MT4X will repeat from the tape counter location "0000" to the stored point.
- Playback is repeated 16 times continuously, then the tape is rewound back to the first memory location and stopped. The REPEAT indicator is switched off.
- You cannot change the memory locations during repeat playback.
- The repeat interval must be more than three counts on the tape counter.

Recording Levels Function

The MT4X will store the maximum recording level for all four tracks and the stereo signal. The location of the highest level is also stored and can be displayed along with the level.

If the signal is beyond the recommended level, the maximum level segment will flash.

dbx™ ON	≥+10dB
dbx™ OFF	≥+6dB

Confirm the maximum level

- 1) Press and hold the CHECK key.
- 2) Press the REHE key (28).

The maximum level segment of the level meters (36) will light for as long as the two keys are pressed. If the level is beyond the recommended level, the segment will flash.

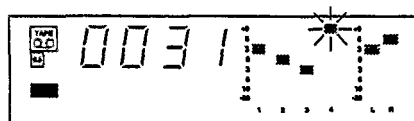

Confirm the tape position

- 1) Press and hold the CHECK key.
- 2) Press the REC SELECT key (17) corresponding to the track you want to check.

The maximum level segment of the selected track will light and the tape counter will display the corresponding location value for as long as the two keys are pressed. If the level is beyond the recommended level, the segment will flash.

The following display shows Track 2 being checked.



Note: If the maximum level is reached a several locations, only the first location is displayed.

If you reset the tape counter after the recording, the location displayed will be incorrect. Unlike the memo function, the MT4X does not re-calculate the maximum level memory locations.

Clear the maximum level data

- 1) Press and hold the STOP key (33).
- 2) Press the CLEAR key (22).

When the data is cleared, the -20 dB segments on the level meters for all four tracks and the stereo signal will flash three times.

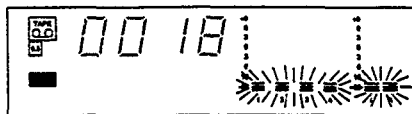

Note: The maximum recording level data is NOT cleared automatically. Before each recording, you should reset the stored levels. Otherwise you could mistake the levels of a previous recording for the current recording.

Appendix

Troubleshooting

If you experience difficulty operating the MT4X, or it does not seem to be working as it should, look up the problem in the following table. You may find it is just a simple error, easy to correct.

Symptom	Possible Cause	Solution
The MT4X cannot be powered ON.	The power cable is not correctly connected.	Make sure the power cable is connected to a suitable AC outlet and plugged into the AC IN connector on the MT4X's rear panel.
	The POWER switch has not been correctly set.	Make sure the POWER switch on MT4X's rear panel is pressed ON.
	Note: <i>If the MT4X still cannot be powered ON, please contact your Yamaha dealer.</i>	
Cannot record.	The REC SELECT key is not set correctly.	Set the REC SELECT key correctly.
	The setting of the ASSIGN key(s) is incorrect.	Select the correct ASSIGN key(s) for the group and tracks you intend to use.
	The cassette is loaded incorrectly.	Make sure the tape is firmly inserted in the cassette compartment.
	The cassette's record protect tabs have been removed.	Make sure that the cassette's record protect tabs are intact.
Cannot hear a connected instrument.	The corresponding input select key is set incorrectly.	Set the input select key to the correct position.
	The fader or monitor is set incorrectly.	Raise the fader for the input module. Make sure the MONITOR SELECT switch is set to CUE and adjust the CUE LEVEL control.
Recordings sound noisy or distorted.	The recording level is set incorrectly.	Set the channel fader so that the level occasionally reaches +9 dB (with dbx™ ON or +3 dB with it OFF). If the signal level is too low, the recording may sound noisy. If it is too high, distortion may occur.
Recordings sound dull, suffer from wow and flutter, or are of poor quality.	The record/playback head and capstan is dirty.	Clean the record/playback head and mechanism. See "Maintenance" on page 45.
	The wrong type of cassette is being used.	Be sure to use high-quality Type II (High Bias, 70 µs EQ) chrome cassettes.
	The cassette tape is defective.	Try a new cassette tape.
Recordings playback at the wrong pitch.	The PITCH control was reset during recording.	Set the PITCH control to the "0" centre-detent position.
	The tape speed was reset.	Press the tape speed select key to set the MT4X back to the correct tape speed.
Tape sync does not function correctly.	The SYNC key was not pressed when the dbx™ system was ON.	Press the SYNC key and connect the FSK source to track 4.
	The FSK track was recorded at too low a level.	Re-record the FSK signal. Make sure the recording level is set to about +3dB.
	The MIDI-to-FSK converter is incorrectly connected.	Make sure the connections are correct.

Maintenance

The MT4X requires regular maintenance to remain in top operating condition. If you observe the following problems, you should clean and possibly demagnetize the unit:

- A drop in level at high frequencies.
- An increase in wow and flutter.
- Fluctuating sound or signal dropout.
- Excessive noise.

Cleaning the recording head and components

The record/playback head is in constant contact with the recording tape. Over time it will become coated with an oxide residue and need to be cleaned. The other components — the capstan and pinchroller — also tend to become coated with residue and dust particles.

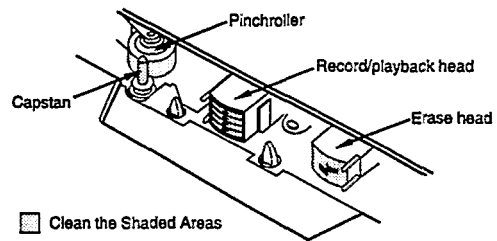

To clean the record/playback head and capstan, use a head-cleaning kit. These kits generally include specially-made cotton swabs and an isopropyl alcohol-based cleaning solution, and are available at audio and electronics shops. Follow the directions on the kit, carefully wiping the record/playback head and the capstan with a swab soaked in cleaning solution. It is best to clean the pinchroller with a non-alcohol based rubber cleaning solution, which is often included in the cleaning kits. Alcohol tends to dry out and corrode the rubber part of the roller.

You should clean the record/playback head and capstan after every 10 hours of use.

Demagnetizing the recording head

As the recording tape passes over the record/playback head, it tends to impart a tiny amount of magnetism to the head. The head collects this magnetism over a period of time, slowly becoming magnetized. You need to demagnetize the head using a commercially-available head demagnetizer. These are also available at most audio and electronics shops.

Note: Read the directions on the demagnetizer carefully. If you do not use the demagnetizer correctly, you could seriously damage the record/playback head. Also, keep recorded tapes away from the demagnetizer when it is in use; the demagnetizer can accidentally erase your tapes.

You should demagnetize the record/playback head after every 20 to 30 hours of use.

Specifications

Model

4-track/4-channel one direction recording and playback cassette recorder with mixer

Tape Transport

Tape Type	C-46 ~ 90 cassette tapes CrO ₂ - Type II (Bias: HIGH; EQ 70 μs)
Track Configuration	4-track/4-channel one direction recording and playback
Heads	4-track Hard Permalloy record/playhead x 1 4-track ferrite erase head x 1
Motor	DC servo motor x 1
Tape Speed	9.5 cm/sec, 4.8 cm/sec
Pitch Control	Approximately ±10%
Wow & Flutter	0.1% WRMS (9.5 cm/sec)

Electrical Specifications

Input connectors	MIC/LINE x 4 AUX RETURN L/MONO, R x 2
Output connectors	AUX SEND x 2 STEREO OUT L, R x 1 MONITOR OUT L, R x 1 TAPE OUT x 4 PHONES L, R x 1

Connectors

MIC/LINE	Input impedance	10 kΩ
	Nominal input level	-10 dB to -50 dB (input fader nominal)
	Minimum input level	-56 dB (GAIN control MAX, input fader maximum)
	Maximum input level	+10 dB (GAIN control MIN, headroom margin)
AUX RETURN L/R 1,2	Input impedance	10 kΩ
	Nominal input level	-10 dB (AUX RETURN - LEVEL control nominal)
	Minimum input level	-16 dB (AUX RETURN - LEVEL control maximum)
STEREO OUT L,R	Output impedance	1 kΩ
	Nominal load impedance	10 kΩ or more
	Nominal output level	-10 dB (at 10 kΩ load)
AUX SEND 1,2	Output impedance	1 kΩ
	Nominal load impedance	10 kΩ or more
	Nominal output level	-10 dB (at 10 kΩ load)
MONITOR OUT L/R	Output impedance	1 kΩ
	Nominal load impedance	10 kΩ or more
	Nominal output level	-10 dB (at 10 kΩ load)
TAPE OUT 1, 2, 3, SYNC/4	Output impedance	1 kΩ
	Nominal load impedance	10 kΩ or more
	Nominal output level	-10 dB (at 10 kΩ load)
PHONES (stereo)	Nominal load impedance	8 to 40 Ω
	Maximum output level	45mw + 45mw (at 40 Ω load)

Mixer

Frequency response (at nominal input and output)	20 Hz to 20kHz +1 dB /- 3dB	MIC IN - STEREO OUT LINE IN-STEREO OUT LINE IN-PHONES OUT
--	-----------------------------	---

Specifications (continued)

Signal-to-Noise ratio (at nominal input and output)	68 dB / IHF-A	MIC IN - STEREO OUT (GAIN control MAX)
	75 dB/IHF-A	LINE IN - STEREO OUT (GAIN control MDM)
Distortion (1 kHz at nominal input and output)	0.1%/30kHz LPF	MIC IN - STEREO OUT (GAIN control MAX)
	0.03%/30kHz LPF	LINE IN - STEREO OUT (GAIN control MIN)
Equalizer	LOW	±12 dB at 80 Hz - Shelving
	MID	±12 dB at 1 kHz - Peaking
	HIGH	±12 dB at 12 kHz - Shelving

Recorder

Frequency Response	40 Hz to 18 kHz, ±3 dB (Tape speed - 9.5 cm/sec, dbx™ NR - OFF)	
Signal-to-Noise ratio	85 dB / IHF-A (at 3% distortion level, dbx™ NR - ON)	
Distortion	2.0% (400 Hz, -10 dB record level)	
Channel separation	70 dB (1 kHz, -10 dB level, BPF, dbx™ NR - ON)	
Erase rate	55 dB (1 kHz, 0 dB record level, dbx™ NR - OFF)	
Noise reduction	dbx™	

General

Control jacks	PUNCH I/O (FC5)	
Power requirements	US and Canada	120 V AC, 60 Hz
	General	230 V AC, 50 Hz
Power consumption	19 W	
Dimensions ⁴ (WxHxD)	414.2 x 110.7 x 311.3 mm	
Weight	4.4 kg	
Accessories	AC power cord	

0 dB = 0.775 V rms

- Specifications are subject to change without notice.
- The dbx™ noise reduction system was manufactured based on a patent licence from THAT Corporation. dbx is a trademark of Carillion Electronics Corporation.

Block Diagram

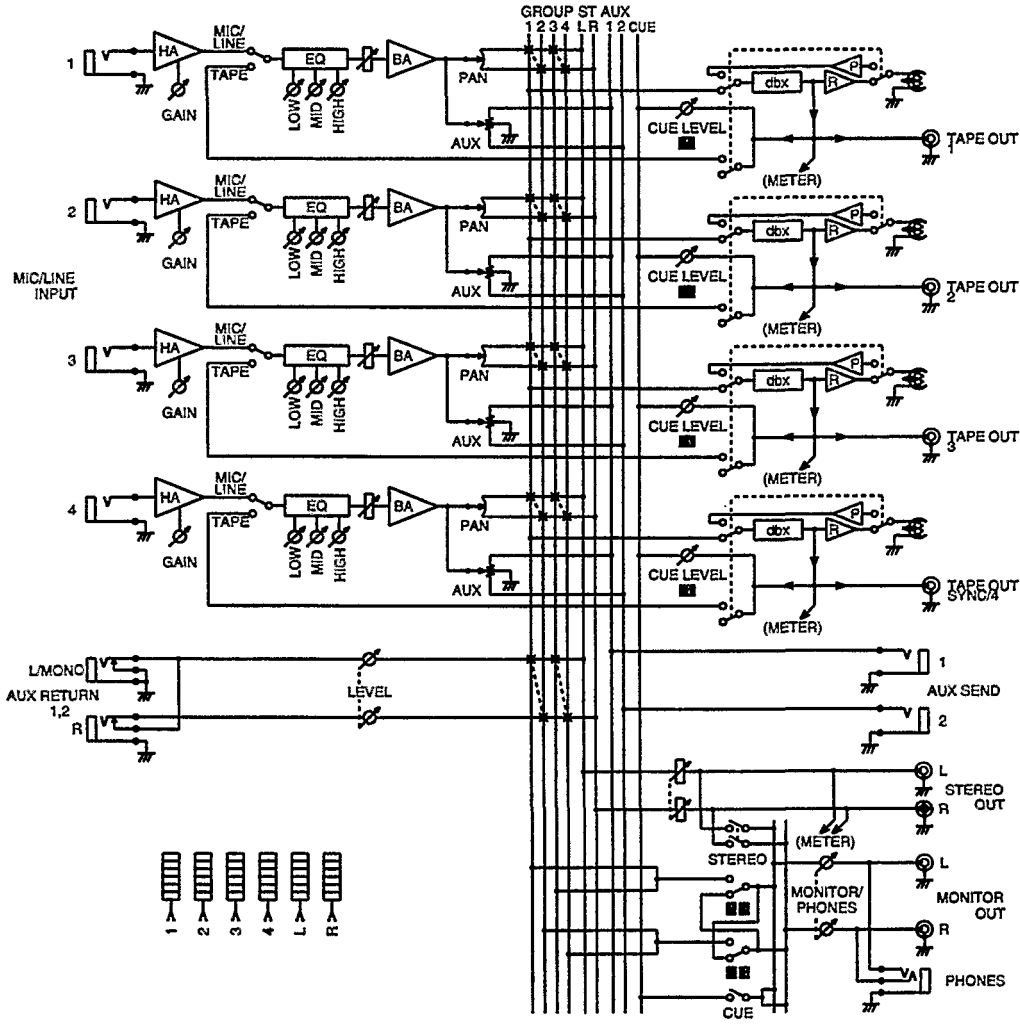

Dimensions

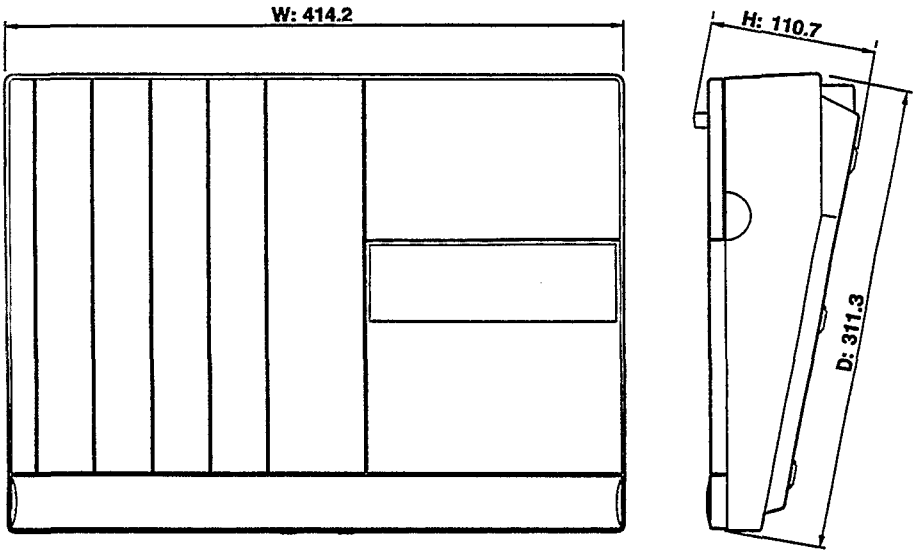

Tracking Sheet

There is a tracking sheet template on the back cover of this manual. You should make a number of photocopies and use them to keep a log of your recording sessions.

Initial tracks

Recording the bassguitar and drum machine:

MIXER				
Channel	1	2	3	4
Input	<input type="checkbox"/> TAPE <input checked="" type="checkbox"/> MIC/LINE	<input type="checkbox"/> TAPE <input checked="" type="checkbox"/> MIC/LINE	<input type="checkbox"/> TAPE <input checked="" type="checkbox"/> MIC/LINE	<input type="checkbox"/> TAPE <input checked="" type="checkbox"/> MIC/LINE
Source	Drum Machine		BASS	
Assign	<input checked="" type="checkbox"/> 1 <input type="checkbox"/> 2 <input type="checkbox"/> 3 <input type="checkbox"/> 4	<input checked="" type="checkbox"/> 1 <input type="checkbox"/> 2 <input type="checkbox"/> 3 <input type="checkbox"/> 4	<input checked="" type="checkbox"/> 1 <input type="checkbox"/> 2 <input type="checkbox"/> 3 <input type="checkbox"/> 4	<input checked="" type="checkbox"/> 1 <input type="checkbox"/> 2 <input type="checkbox"/> 3 <input type="checkbox"/> 4
Pan				
AUX				
EQ				
Fader				

RECORDER				
Track	1	2	3	4
Source	Drum Machine	BASS		

AUX	
Channel	1
Effect	
Assign	<input checked="" type="checkbox"/> 1 <input type="checkbox"/> 2 <input type="checkbox"/> 3 <input type="checkbox"/> 4
Aux	

POSITION	
Start	0004
Stop	0475

MT4X TRACKING SHEET

Title: the Big Bear

Step: 1 Date: Jan 1st

Process: Rhythm tracks

Note: Added eq to bass guitar. Bass run thru lots of fx-pedals

Overdubbing

Recording the synthesizer and MIDI tone generator:

MIXER				
Channel	1	2	3	4
Input	<input type="checkbox"/> TAPE <input checked="" type="checkbox"/> MIC/LINE	<input type="checkbox"/> TAPE <input checked="" type="checkbox"/> MIC/LINE	<input type="checkbox"/> TAPE <input checked="" type="checkbox"/> MIC/LINE	<input type="checkbox"/> TAPE <input checked="" type="checkbox"/> MIC/LINE
Source		Synth	MIDI Organ	
Assign	<input checked="" type="checkbox"/> 1 <input type="checkbox"/> 2 <input type="checkbox"/> 3 <input type="checkbox"/> 4	<input checked="" type="checkbox"/> 1 <input type="checkbox"/> 2 <input type="checkbox"/> 3 <input type="checkbox"/> 4	<input checked="" type="checkbox"/> 1 <input type="checkbox"/> 2 <input type="checkbox"/> 3 <input type="checkbox"/> 4	<input checked="" type="checkbox"/> 1 <input type="checkbox"/> 2 <input type="checkbox"/> 3 <input type="checkbox"/> 4
Pan				
AUX				
EQ				
Fader				

RECORDER				
Track	1	2	3	4
Source			Synth & MIDI Organ	

AUX	
Channel	1
Effect	Rotary speaker effect
Assign	<input checked="" type="checkbox"/> 1 <input type="checkbox"/> 2 <input type="checkbox"/> 3 <input type="checkbox"/> 4
Aux	

POSITION	
Start	0042
Stop	0499

MT4X TRACKING SHEET

Title: the Big Bear

Step: 2 Date: Jan 1st

Process: Synth tracks

Note: Rotary speaker effect on MIDI organ. EQ boost in lower range.

Recording the vocals:

MIXER				
Channel	1	2	3	4
Input	<input type="checkbox"/> TAPE <input checked="" type="checkbox"/> MIC/LINE	<input type="checkbox"/> TAPE <input checked="" type="checkbox"/> MIC/LINE	<input type="checkbox"/> TAPE <input checked="" type="checkbox"/> MIC/LINE	<input type="checkbox"/> TAPE <input checked="" type="checkbox"/> MIC/LINE
Source	Lead vocal		Backing vocal1	Backing vocal2
Assign	<input checked="" type="checkbox"/> 1 <input type="checkbox"/> 2 <input type="checkbox"/> 3 <input type="checkbox"/> 4	<input type="checkbox"/> 1 <input checked="" type="checkbox"/> 2 <input type="checkbox"/> 3 <input type="checkbox"/> 4	<input type="checkbox"/> 1 <input type="checkbox"/> 2 <input checked="" type="checkbox"/> 3 <input type="checkbox"/> 4	<input type="checkbox"/> 1 <input type="checkbox"/> 2 <input type="checkbox"/> 3 <input checked="" type="checkbox"/> 4
Pan				
Aux				
EQ				
Fader				

RECORDER				
Track	1	2	3	4
Source				Lead & backing vocals

AUX		
Channel	1	2
Effect	Stereo w/each channel returned to different AUX	Reverb
Assign	<input checked="" type="checkbox"/> 1 <input type="checkbox"/> 2 <input type="checkbox"/> 3 <input type="checkbox"/> 4	<input type="checkbox"/> 1 <input checked="" type="checkbox"/> 2 <input type="checkbox"/> 3 <input type="checkbox"/> 4
Aux		

POSITION	
Start	0101
Stop	0475

MT4X TRACKING SHEET

Title: the Big Beat
 Step: 3 Date: Jan 1st
 Process: Vocals
 Note: Reverb is only used for the monitor channels (not assigned or recorded). Monitor "STEREO" bus. EQ cut on backing vocals.

Mixdown

Add equalization and effects and record to the master recorder:

MIXER				
Channel	1	2	3	4
Input	<input type="checkbox"/> TAPE <input checked="" type="checkbox"/> MIC/LINE	<input type="checkbox"/> TAPE <input checked="" type="checkbox"/> MIC/LINE	<input type="checkbox"/> TAPE <input checked="" type="checkbox"/> MIC/LINE	<input type="checkbox"/> TAPE <input checked="" type="checkbox"/> MIC/LINE
Source	Drum Machine	Bass	Synth & MIDI Organ	Lead & backing vocals
Assign	<input checked="" type="checkbox"/> 1 <input type="checkbox"/> 2 <input type="checkbox"/> 3 <input type="checkbox"/> 4	<input type="checkbox"/> 1 <input checked="" type="checkbox"/> 2 <input type="checkbox"/> 3 <input type="checkbox"/> 4	<input type="checkbox"/> 1 <input type="checkbox"/> 2 <input checked="" type="checkbox"/> 3 <input type="checkbox"/> 4	<input type="checkbox"/> 1 <input type="checkbox"/> 2 <input type="checkbox"/> 3 <input checked="" type="checkbox"/> 4
Pan				
Aux				
EQ				
Fader				

RECORDER				
Track	1	2	3	4
Source				

AUX		
Channel	1	2
Effect	Vocal reverb	Flanger delay
Assign	<input checked="" type="checkbox"/> 1 <input type="checkbox"/> 2 <input type="checkbox"/> 3 <input type="checkbox"/> 4	<input type="checkbox"/> 1 <input checked="" type="checkbox"/> 2 <input type="checkbox"/> 3 <input type="checkbox"/> 4
Aux		

POSITION	
Start	0005
Stop	0499

MT4X TRACKING SHEET

Title: the Big Beat
 Step: 4 Date: Jan 1st
 Process: Mixdown
 Note: Lots of reverb on vocals and flanger/delay on instruments to get that big beat sound.

Glossary

Auxiliary Bus

The MT4X has two auxiliary buses. These buses are generally used to send signals to external signal processing units.

Auxiliary Send— Each channel module includes an AUX control, which selects an auxiliary bus and determines the amount of signal fed to corresponding the AUX SEND output connector.

Auxiliary Return— The AUX RETURN controls determine the destination and amount of signal that is fed back into the MT4X via the AUX RETURN input connectors. You can return an effect in stereo, to further enhance your recording.

Capstan

A slender metal pillar adjacent to the pinchroller. The capstan is driven by the DC servo motor and controls the tape speed. The tape pulled across the erase and record/playback heads by the pressure between the capstan and pinchroller.

CUE monitor

This bus is used to listen to previously recorded tracks. It is mostly used to assist the musicians recording a new part. You can also process effects through the monitor bus without recording them to tape. The CUE bus is monaural.

DAT (Digital Audio Tape)

A two-channel, 16-bit digital recording system using magnetic tape and a rotary head mechanism. DAT machines are often used as master recording units. Professional units can record at 33 kHz, 44.1 kHz, and 48 kHz sampling rates.

dbx™ noise reduction

A system to reduce tape noise and improve the dynamic range of analog tape. dbx™ employs a pre-emphasis to boost the high frequencies, followed by a 2:1 compression of the signal during recording. The signal is expanded and then de-emphasized on playback. The MT4X uses dbx™ noise reduction to reduce noise and keep your recordings clean and crisp.

Demagnetizer

A hand-held device that removes the residual magnetic field that routinely builds up on a recording head. Without demagnetizing (also called degaussing), this residual magnetic field can cause distortion. Use of a demagnetizer is an integral part of maintaining any tape recorder.

Equalization (EQ)

The process of adjusting (boosting or cutting) the frequency ranges for optimal sound. Many engineers try to record with flat equalization, only adjusting the frequencies on mixdown.

Fader

Each channel module contains a fader, a slider that is used to adjust the level of that channel relative to the other channels. The MASTER module fader is used to adjust the overall stereo level.

FSK (Frequency Shift Keying)

A method of recording MIDI clock data onto one of the tracks of the MT4X. A device translates the data into two distinct frequencies that represent the two binary states: "on" and "off". Some MIDI instruments can directly output FSK sync signals. Otherwise, you will need a MIDI/FSK converter such as the Yamaha YMC10.

GAIN

Various musical instruments and devices output different levels of signal. Gain is a measure of electronic input over output. Each channel module includes a GAIN control that can alter the input levels to compensate for line, instrument, or microphone levels.

Head

A transducer used to convert electrical impulses into patterns of magnetism during recording and to convert patterns of magnetism into electrical impulses during playback. The MT4X uses a special 4-track permalloy record/playback head.

Instrument level

The level of gain output by such devices as an electric bass or guitar.

Line level

The level of gain output by such devices as a synthesizer, drum machine, CD player, etc.

Master recorder

A second tape recorder used during the mixdown process. The master recorder can be any two-track stereo recorder, such as a stereo cassette, reel-to-reel, or DAT recorder.

MIC/LINE input

Each channel module includes a MIC/LINE input to connect a microphone, musical instrument, or electronic device for recording.

MIDI (Musical Instrument Digital Interface)

A digital data format standardized to ensure communication compatibility between electronic musical instruments from different manufacturers. MIDI allows you to control multiple instruments from one keyboard.

Mixdown

Usually the final process in a multitrack recording where you combine the previously recorded tracks (often four), plus any effects or signal processing, into a stereo mix.

Module

The MT4X includes four channel modules. Each module consists of an input section (input select key and GAIN control), an equalization section (HIGH, MID, and LOW controls), an auxiliary section, a routing section (ASSIGN keys and PAN control), and a fader.

MONITOR/PHONES control

Controls the amount of signal fed to the speakers through the left and right MONITOR OUT jacks or to the stereo PHONES (headphone) jack.

Multitrack

A tape recorder with more than two tracks. The MT4X is a four-track machine. Each track can be independently recorded at an optimum level, and then mixed, equalized, processed, and panned into a final mixdown.

Overdub recording

Recording one track while listening to another track or tracks. The process of overdubbing can also be implemented by a synthesizer synchronized to a sync track. See Synchronization.

Pan

A control that sets the relative position of a sound in a stereo image. Each channel module includes a PAN control. The PAN control is also used for track group assignment.

Pinchroller

A small rubber wheel which presses the tape against the capstan.

Ping-Pong recording

Also known as bouncing. The transfer of recordings from several tracks to one other track effectively increase the number of tracks available for recording.

Pitch

The frequency of a musical sound — its relative highness or lowness compared to other notes. The PITCH control changes the pitch of a playback by fine-tuning the speed at which the tape passes over the head.

Post-fader

MT4X's auxiliary sends are configured post fader, which means that the send signal is sourced after the fader. To feed a signal to an external effects processor via the auxiliary send, turn up the AUX control and raise the fader. The advantage is that you can fade both channel and auxiliary send signals simultaneously. Compare with Pre-fader.

Pre-fader

A signal that is sourced before the fader, therefore, the fader has no control on the signal.

Punch-In/Out recording

A recording technique used primarily to correct mistakes by re-recording over a short section of a track.

Stereo mix

A two-track mix with left and right stereo channels. The finished product of a mixdown session.

Striping the tape

Applying a timecode to the tape for synchronization purposes. On the MT4X, you apply the timecode to Track 4.

Synchronization

The technique of coordinating external MIDI instruments and the playback of the MT4X via a timecode. See Overdub recording.

Track

A physical band on a recording tape created by a recording head. The MT4X creates four tracks on one side of a standard audio cassette.

Tracking sheet

A chart that lists what was recorded on each track, the settings used, and in what order.

Tracking Sheet

RECORDER				
Track	1	2	3	4
Source				

POSITION	
Start	
Stop	

AUX		
Channel	1	2
Effect		
Assign		
Aux		

MT4X
TRACKING
SHEET

Title: _____

Step: _____ Date: _____

Process: _____

Notes: _____

MIXER				
Channel	1	2	3	4
Input	<input type="checkbox"/> TAPE <input type="checkbox"/> MIC/LINE	<input type="checkbox"/> TAPE <input type="checkbox"/> MIC/LINE	<input type="checkbox"/> TAPE <input type="checkbox"/> MIC/LINE	<input type="checkbox"/> TAPE <input type="checkbox"/> MIC/LINE
Source				
Assign				
Pan				
Aux				
EQ				
Fader				

MT4X OM
5/20/99 19E0112



MT4X OM