

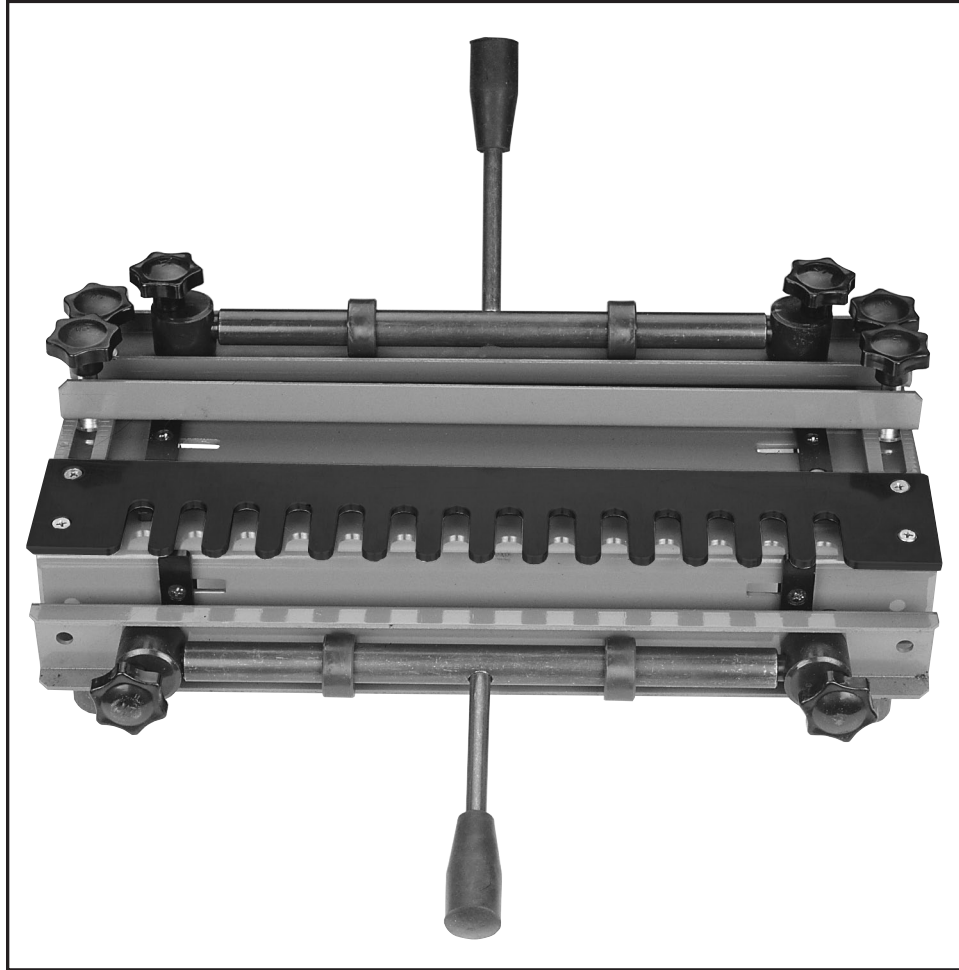

P.O. Box 2309  
Bellingham, WA 98227



# DOVETAIL JIG W1099 OPERATING MANUAL

COPYRIGHT © BY WOODSTOCK INTERNATIONAL, INC. TX 4-085-998  
WARNING: NO PORTION OF THIS MANUAL MAY BE REPRODUCED IN ANY SHAPE  
OR FORM WITHOUT THE WRITTEN APPROVAL OF WOODSTOCK INTERNATIONAL, INC.  
REPRINTED FEBRUARY 1999, PRINTED IN TAIWAN

---

# TABLE OF CONTENTS

---

I.	INTRODUCTION.....	2
II.	COMMENTARY.....	2
III.	SAFETY RULES FOR ALL TOOLS.....	3
IV.	UNPACKING.....	4
V.	ASSEMBLY.....	4
	A.    HAND LEVERS.....	4
	B.    MOUNTING.....	4
VI.	CAPACITIES.....	5
VII.	PREPARATION.....	5
VIII.	ADJUSTMENT LOCATIONS.....	6
IX.	CLAMP ADJUSTING.....	7
X.	SIDE STOP SET UP.....	7
XI.	TEMPLATE ADJUSTMENT.....	9
XII.	FENCE ADJUSTMENT.....	10
XIII.	OPERATIONS.....	11
	A.    REGULAR USE.....	11
	B.    RABBETED DRAWER FRONTS.....	13
XIV.	TROUBLESHOOTING.....	14
	A.    TEAR OUT.....	14
	B.    EXCESSIVE FIT.....	14
	C.    INCOMPLETE FIT.....	14
	D.    OFFSET EDGES.....	15
	E.    FIT TOO TIGHT OR TOO LOOSE.....	15
	F.    UNEVEN FIT.....	15
XV.	WARRANTY.....	16
XVI.	CLOSURE.....	16
XVII.	PARTS DIAGRAM.....	17
XVIII.	PARTS LIST.....	18
XIX.	TOOL DATA.....	18
XX.	INDEX.....	19

COPYRIGHT © BY WOODSTOCK INTERNATIONAL, INC. TX 4-085-998  
WARNING: NO PORTION OF THIS MANUAL MAY BE REPRODUCED IN ANY SHAPE  
OR FORM WITHOUT THE WRITTEN APPROVAL OF WOODSTOCK INTERNATIONAL, INC.  
REVISED FEBRUARY 1999, PRINTED IN TAIWAN

---

## I. INTRODUCTION

---

Woodstock International, Inc. is proud to offer the W1099 12" Dovetail Jig. Suitable for production work or small scale dovetail joinery, the Model W1099 enables you to simultaneously cut  $\frac{5}{8}$ " half-blind dovetails and pins with a router, guide bushing, and dovetail bit. The Dovetail Jig handles stock up to  $1\frac{1}{4}$ " thick and 12" wide and mounts easily to your bench top. Heavy, stamped steel construction provides excellent rigidity and strength, while the horizontal and vertical cam action clamps securely hold your wood in place.

Woodstock is committed to offering top quality products and supporting them through customer service and technical documentation. The manual you are reading represents our latest effort to produce the best documentation possible. If you have any criticisms or comments you feel we should consider for our next printing, please write us at the address below.

Manager, Technical Documentation  
Woodstock International, Inc.  
P.O. Box 2309  
Bellingham, WA 98227

If you have any parts problems or requests, please contact the dealer where the W1099 Dovetail Jig was purchased or call Woodstock International at 1-800-840-8420 between 8am and 5pm Pacific Standard Time, Monday through Friday.

---

---

## II. COMMENTARY

---

To operate this, or any tool, safely and efficiently, it is essential to become as familiar with its characteristics as possible. Take as much time as necessary to become acquainted with the W1099 Dovetail Jig. The time you invest before you use it will be time well spent. Also, read and follow all of the safety procedures noted in this manual. If you do not understand any of the operations or safety guidelines discussed in this manual, please answer all questions before attempting to use this jig. The specifications, drawings, and photographs illustrated in this manual represent the Model W1099 as supplied when the manual was prepared. But owing to Woodstock's policy of continuous improvement, changes to the Model W1099 may occur at any time with no obligation on the part of Woodstock. Should you receive a manual update, please keep it with the manual for future reference.

The information in this manual has been obtained from sources we believe to be as reliable and as up-to-date as possible. We have included some important safety measures which we believe to be essential to this tool's operation. While most safety measures are generally universal, Woodstock reminds you that each work environment is different and safety rules should be considered as they apply to your situation.

We also believe additional sources of information are important to realize the full potential of this tool. Trade journals, woodworking magazines, and your local library are good places to find such information.

### **WARNING**

The Model W1099 was designed for making precise dovetails. It must never be modified and/or used for any other purpose. Modifications or improper use of this tool will void all warranties and MAY CAUSE SERIOUS PERSONAL INJURY. If you are confused about any aspect of the jig, DO NOT use it until you have resolved any questions you might have.

---

### III. SAFETY RULES FOR ALL TOOLS

---

1. **KNOW YOUR POWER TOOL.** Read the owner's manual carefully. Learn the tool's applications and limitations, as well as its particular hazards.
2. **KEEP ALL GUARDS IN PLACE** and in working order.
3. **GROUND ALL TOOLS.** If an adapter is used to accommodate a two-prong receptacle, the adapter plug must be attached to a known ground. Never remove the grounding prong.
4. **REMOVE ADJUSTING KEYS AND WRENCHES.** Make it a habit to check that keys and adjusting wrenches are removed from the machine before turning it on.
5. **KEEP WORK AREA CLEAN.** Cluttered areas and benches invite accidents.
6. **AVOID DANGEROUS ENVIRONMENTS.** Do not use power tools in damp or wet locations or expose them to rain. Keep your work area well lighted.
7. **KEEP CHILDREN AND VISITORS AWAY.** All children and visitors should be kept a safe distance away from your work area.
8. **MAKE WORKSHOP CHILD-PROOF** with padlocks, master switches, or by removing starter keys.
9. **DO NOT FORCE TOOL.** Tools work better and more safely when they are allowed to work at their own speed.
10. **WEAR PROPER APPAREL.** Do not wear loose clothing, gloves, neckties, or jewelry that might get caught in moving parts. Non-slip footwear should be worn. Wear a hat or other protective head wear if your hair is long.
11. **NEVER STAND OR LEAN ON TOOL.**
12. **USE SAFETY GLASSES AND EAR PROTECTION.** Also use a **DUST MASK** if the cutting operation is dusty.
13. **DO NOT OVERREACH.** Keep proper footing and balance at all times.
14. **MAINTAIN TOOLS IN TOP CONDITION.** Keep tools sharp and clean for best and safest performance. Follow instructions for lubricating and changing accessories.
15. **DISCONNECT TOOLS FROM POWER** before servicing and when changing accessories, such as blades, bits, and cutters.
16. **AVOID ACCIDENTAL STARTING.** Make sure the switch is in the "OFF" position before plugging in the cord.
17. **CHECK DAMAGED PARTS.** Do not operate the machine until you are certain it is in perfect running condition.
18. **NEVER LEAVE THE TOOL RUNNING UNATTENDED - TURN POWER OFF.** Do not leave the tool until it comes to a full stop.
19. **DO NOT OPERATE THE TOOL IF USING DRUGS, ALCOHOL, OR MEDICATION.**
20. **DO NOT WORK IN HASTE** or operate machine if you are mentally or physically fatigued.
21. **IF THERE IS SOMETHING YOU DO NOT KNOW OR UNDERSTAND, DO NOT OPERATE MACHINE!** Ask for help first. Confusion can be dangerous.
22. **BAD HABITS ARE DANGEROUS.** Review all safety procedures often.

These safety rules cannot cover every situation in a woodshop. Consider your conditions when setting up and using your jig.

---

## IV. UNPACKING

---

Remove the items packed in the carton. It may be a good idea to save the carton and packing material in case they might be needed in the future. Upon removal of all items from the package, you should have:

1. Dovetail Jig
2. Hand Levers (2)
3. Manual

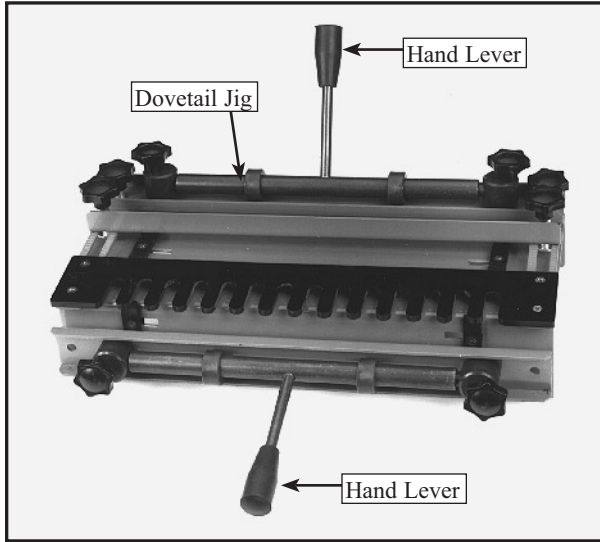

Figure 1 shows the dovetail jig with handles.

---

## V. ASSEMBLY

---

### A. HAND LEVERS

The jig is shipped fully assembled except for the two hand levers. Screw the threaded end of each hand lever into the clamping rods located on the top and front of the dovetail jig. Tighten until secure. Figure 1.

### B. MOUNTING

1. Place the jig on your bench top so the front lap rests against the front of the bench top.
2. Locate the mounting holes in the rear of the jig. Scribe the hole locations and determine whether to use nuts and bolts, or lag screws. Drill the appropriate size holes.
3. Secure the jig to your bench top. Screws can be tightened by inserting a long screwdriver through the unthreaded holes in the back of the jig.

Hint: If you do not wish to permanently devote bench space to the dovetail jig, mount the jig to a piece of  $\frac{3}{4}$ " plywood that can be clamped to your bench top.

## VI. CAPACITIES

The W1099 is designed to produce half-blind dovetail joints with a router,  $\frac{7}{16}$ " guide bushing, and  $14^\circ$ ,  $\frac{1}{2}$ " dovetail router bit. Half-blind dovetails are very strong and are commonly used in fine drawer construction. The term "half-blind" refers to the fact that the pins and tails can only be seen from the side.

1. The W1099 is capable of processing material up to  $1\frac{1}{4}$ " thick and up to 12" wide.
2. It is designed to be used with  $\frac{1}{4}$ " shank,  $\frac{1}{2}$ ",  $14^\circ$  dovetail bits only. The bit should protrude approximately  $\frac{17}{32}$ " below the base.
3. The maximum router base size that can be used with this jig is 7" in diameter.
4. The guide bushing should protrude  $\frac{1}{8}$ " to  $\frac{3}{16}$ " from the base of the router and be  $\frac{7}{16}$ " in outside diameter (O.D.).



This jig can only be used with a guide bushing attached to your router base.

The table below shows the pin widths produced by different sized templates. Your jig comes with a  $\frac{1}{2}$ " template. Other templates are available from your local Woodstock dealer.

Template Size	Bit Size	Bushing Size	Pin Width
$\frac{1}{2}$ "	$\frac{1}{2}$ "	$\frac{7}{16}$ "	$\frac{5}{8}$ "
$\frac{7}{16}$ "	$\frac{1}{2}$ "	$\frac{7}{16}$ "	$\frac{1}{2}$ "
$\frac{9}{16}$ "	$\frac{1}{2}$ "	$\frac{7}{16}$ "	$\frac{3}{4}$ "

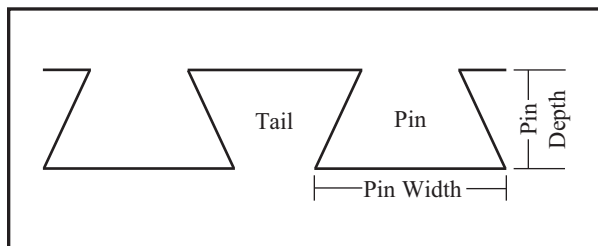

Figure 2 gives a description of dovetail pins.

## VII. PREPARATION

It is important to plan your work before starting. If joining multiple pieces for a drawer or series of drawers, it is best to label the pieces as front, back and sides and which face will be inside or outside. It is also best to label the ends so it is clear which end mates with another. Labeling will save setup time and avoid costly mistakes in the long run.

A typical drawer has a  $\frac{3}{4}$ " thick front with sides made of  $\frac{1}{2}$ " material. The dovetail jig's design requires that you use the same stock thickness for the back as you do for the front. Your drawer fronts and backs must be at least  $\frac{5}{8}$ " thick to fully accommodate the length of the dovetails without compromising strength.

After all the pieces have been cut to size and checked to ensure squareness, set them on a bench in the order that they will be fitted together. Lay each piece down so the inside faces up. Label each piece on the inside as shown in Figure 3.

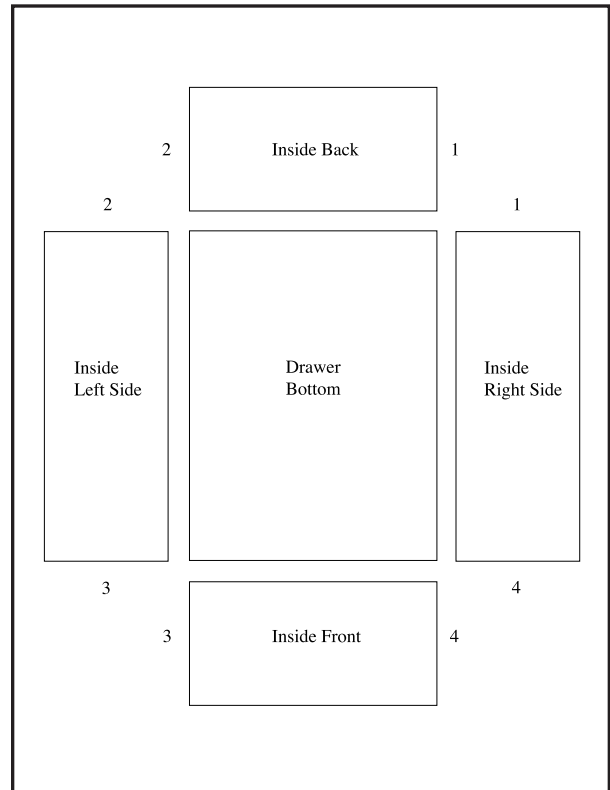

Figure 3 shows the pieces laid out for labeling.

---

## VIII. ADJUSTMENT LOCATIONS

---

The W1099 Dovetail Jig has been designed to accommodate various stock thicknesses and router base sizes. Figure 4 shows the locations for all necessary Dovetail Jig adjustments.

### NOTE

When describing adjustments and operations in this manual, reference is made to the pieces being joined as fronts, backs or sides. These pieces indicate drawer fronts, backs, and sides.

Front and back pieces mount horizontally on top of the jig and side pieces mount vertically in the front of the jig. The insides of the boards always face out!

1. The hand levers clamp your workpiece in place.
2. The fence knobs hold the fence in place. Loosen these knobs to adjust fence position. Router travel is stopped when the router base contacts the fence.
3. The upper side stops align the workpiece horizontally under the template.
4. The front side stops align the vertical workpiece to the horizontal workpiece.
5. The template knobs hold the template in place. Loosen these knobs to adjust template position.
6. The clamping pressure knobs control the height of the clamping bar and adjust cam clamping pressure.

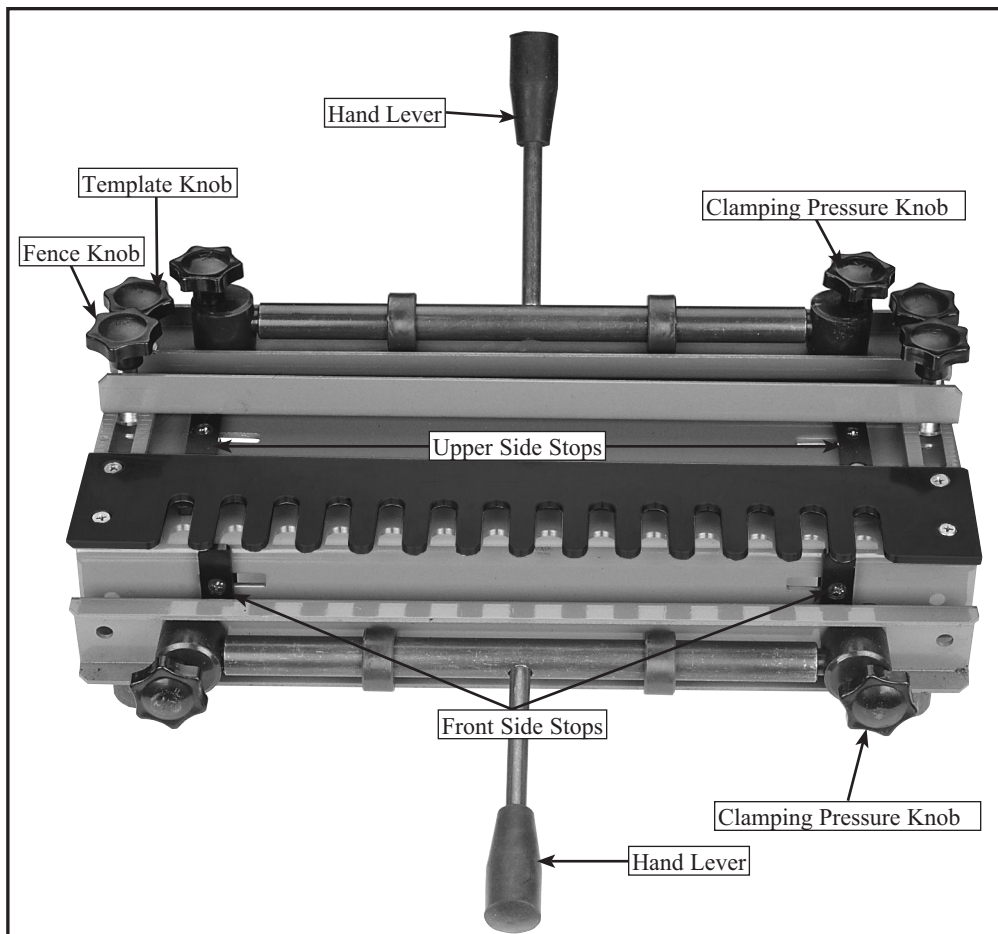

Figure 4 shows the adjustment locations for the dovetail jig.

---

## IX. CLAMP ADJUSTING

---

The clamping pressure should be adjusted so the workpiece can be easily slid under the bar when the hand lever is up. Push the hand lever down to hold the workpiece in place. Figure 5. Do not use excessive force when pushing the lever. If the lever will not lock firmly under normal pressure, loosen the clamping pressure knobs slightly and try again.

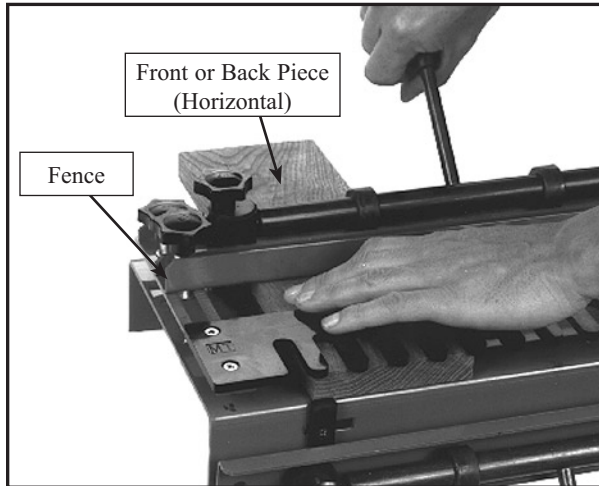

Figure 5 shows clamping down the workpiece.

### IMPORTANT

Since tails and pins are routed in one operation, drawer sides must be offset. The amount of offset is equal to the width of the template fingers.

---

## X. SIDE STOP SET UP

---

The side stops serve three purposes: 1) they position each workpiece square to each other, 2) they offset the two workpieces for proper alignment, and 3) they give lateral support to the workpieces during routing.

**IMPORTANT:** All pieces must be cut perfectly square for the jig to work properly.

To adjust the side stops:

1. Loosen the fence and slide to the rear. Slide the drawer back horizontally under the top clamp and the template. Place the drawer back against either one of the side stops.
2. Loosen the adjustment screws on the side stop and shift the side stop and the workpiece until the wood is centered under the template fingers. Figure 6. Centering ensures that the pins and tails on the ends will be identical to each other. Re-tighten the side stop screws. Do not over-tighten.
3. Grasp the jig template from behind and gently pull it forward. When the template is tight in its full-forward position, clamp the workpiece in place. Repeat this procedure each time you clamp your top workpiece to ensure that subsequent cuts are consistent.

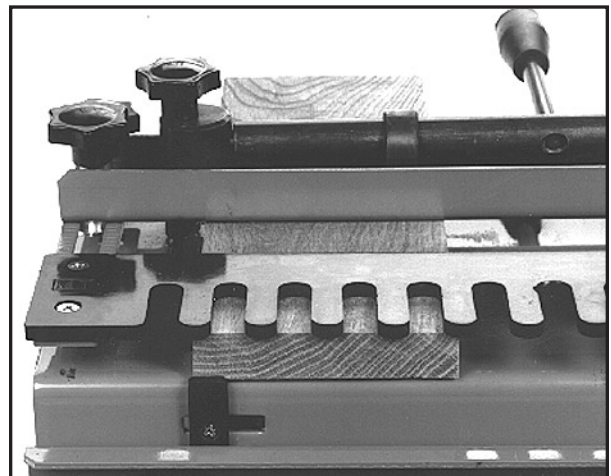

Figure 6 shows the drawer front (or back) equally centered under the fingers of the dovetail jig.



---

## X. SIDE STOP SET UP

---

4. Insert a drawer side under the front clamp. This piece will be vertical. Adjust the height so the end of the vertical board overlaps the end of the horizontal board. At this point it is not crucial that the pieces be flush.
5. Clamp the side in place.
6. Release the horizontal piece and butt it against the side piece mounted in the front of the jig. Ensure that the horizontal piece remains centered under the template fingers. Re-clamp in place.
7. Release the side piece from the front of the jig and remove the front clamping system by unscrewing the clamping adjustment knobs. Remove the template by unscrewing the template adjustment screws.
8. Mark a line on the end of the wood exactly  $\frac{1}{2}$ " from the edge. Use the technique shown in Figure 7 to align the lower left side stop.

If you are using the  $\frac{1}{2}$ " template, scribe the line so the distance from the edge equals the width of the template fingers. (If using the  $\frac{7}{16}$ " template, the offset will be  $\frac{7}{16}$ ".)

9. Loosen the front side stop screws and slide the front side stop against the square. Tighten the two Phillips screws. Be careful: over-tightening could damage the side stops.
10. Replace the front cam clamping system and the template.

Note: The dovetail jig is capable of processing two sets of joints at one time if the sum of the widths of both sets is less than 12". If you wish to make two sets of joints at one time, adjust both sets of side stops at each end of the jig. Refer to Steps 1 through 10 above.

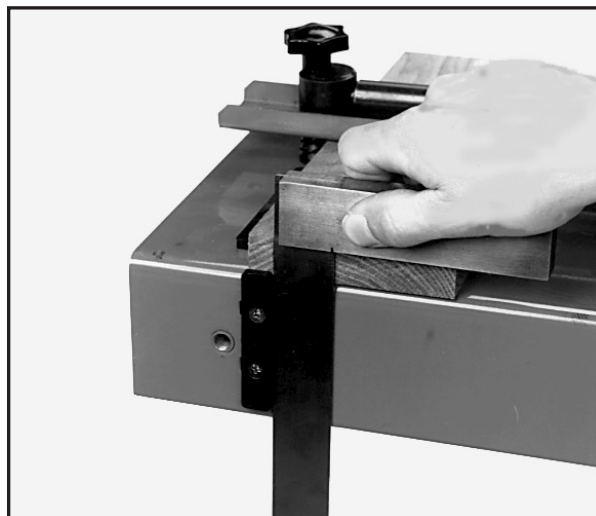

Figure 7 shows aligning the lower left side stop to the line scribed on the end of the front (or back) piece.

### IMPORTANT

For the best results, we recommend using  $\frac{3}{4}$ " (or thicker) material for drawer fronts and backs and material approximately  $\frac{1}{2}$ " (or slightly thicker) for drawer sides. Make sure there is no more than  $\frac{1}{4}$ " difference in wood thickness between the front/back and the sides. Make sure when preparing your lumber for dovetailing – that all materials are squared uniformly to  $90^\circ$ . Out of square lumber will just about guarantee unsatisfactory results.

It is also essential that all adjustments of the jig be set exactly parallel. Before making a cut, inspect:

1. Alignment between front and side workpieces
2. Alignment between the wood and the stops and jig
3. Alignment between the template and the front edge of the wood
4. Alignment between the fence and the front of the template

---

## XI. TEMPLATE ADJUSTMENT

---

The template is adjustable from front to back so that the joint will be hidden when the dovetails are complete. Adjustment is made by loosening the two template lock knobs. Do not adjust the screws holding the template.

To adjust the template to the proper position:

1. Mount your drawer pieces in the jig. The horizontal piece must be tight and flush with the top of the vertical piece. When mounted correctly, the top edge of the vertical piece sits flush with the top of the horizontal piece. Figure 8A.
2. For pieces that are less than  $\frac{7}{8}$ " thick, slide the template so the front edge of the template fingers are  $\frac{1}{8}$ " back from the top edge of the vertical piece. Figure 8B.

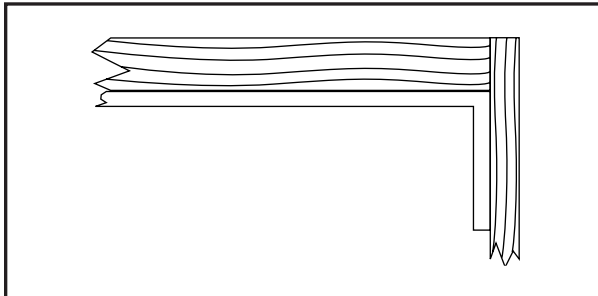

Figure 8A shows the proper positioning between the horizontal and vertical workpieces when mounted in the Dovetail Jig.

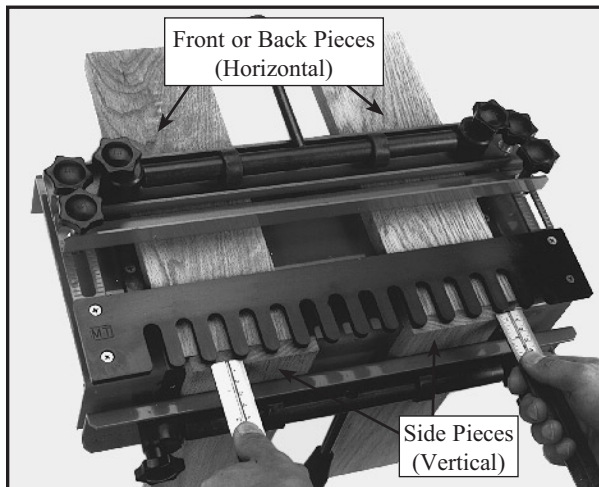

Figure 8B shows checking the template to make sure it is parallel to the top of the vertical pieces. The inside faces are showing.

For side pieces thicker than  $\frac{7}{8}$ ", add  $\frac{1}{8}$ " to the amount that the board exceeds  $\frac{7}{8}$ ". Then, set the front edge of the template fingers back from the edge by that sum. Figure 9.

### **NOTE**

Ensure that the front edge of the template is parallel to the edge of the vertical workpiece. To maintain a high degree of accuracy when adjusting the template, measure at one end of the jig, then measure at the other end. Make adjustments to the template and re-measure both positions.

To measure at both ends of the jig, try shifting the vertical piece to the other end of the jig or clamp two pieces at each end of the jig as shown in Figure 8B. It is not necessary to simultaneously measure with two rulers. The two rulers only represent two measurement locations.

3. Tighten the two template lock knobs and re-check your measurements.

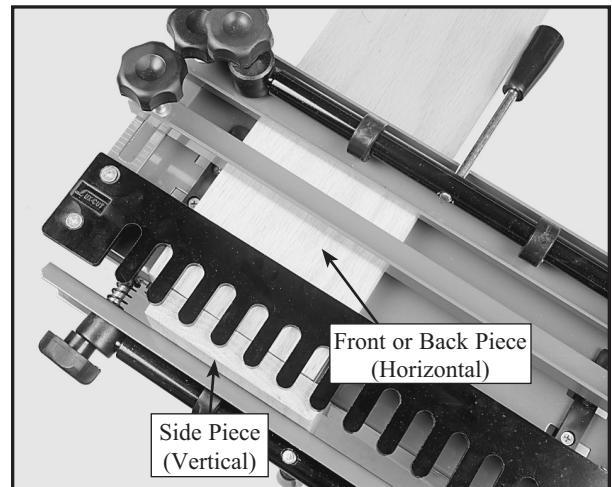

Figure 9 shows the template set back an additional  $\frac{1}{8}$ " for a 1" thick board. The inside faces are showing.

## XII. FENCE ADJUSTMENT

The fence controls the depth of the dovetail pins by limiting the distance that the router travels. The router stops when the router base hits the fence. The fence must be adjusted parallel to the edge of the vertical piece just like the template.

To adjust the fence:

1. Mount a  $\frac{7}{16}$ " O.D. guide bushing in your router base. Measure the amount that the template overlaps the vertical piece. Multiply that number by two. For example, if the template is offset from the edge of the vertical piece by  $\frac{1}{8}$ " and the thickness of the side piece is  $\frac{1}{2}$ ", then the overlap is  $\frac{3}{8}$ ". So,  $\frac{3}{8}$ " x 2 is  $\frac{3}{4}$ ".
2. Now, add  $\frac{1}{32}$ " to the distance you calculated in step 1.
3. Measure the distance from the edge of the router base to the edge of the guide bushing and add it to the distance you calculated in step 2.
4. The distance calculated in step 3 is the distance that the fence should be back from the template. Loosen the two fence lock knobs and slide the fence into position. Ensure that the fence is parallel to the front of the template and tighten the two lock knobs.

Note: The procedure above is not affected by changing the router bit vertical depth of cut.

When you've finished with all the calculations, make a test run using some scrap wood to check your positioning. Fine tune if necessary.

Explanation	Example*	Your Jig
Distance that the template overlaps the vertical piece = A	$A = \frac{3}{8}$ "	$A = \underline{\quad}$ "
Multiply A by 2 = B	$\frac{3}{8}$ " x 2 = B = $\frac{3}{4}$ "	$A \times 2 = B = \underline{\quad}$ "
Add $\frac{1}{32}$ " to B = C	$\frac{3}{4}$ " + $\frac{1}{32}$ " = C = $\frac{25}{32}$ "	$B + \frac{1}{32}$ " = C = $\underline{\quad}$ "
Add C to distance from edge of bushing to edge of router base, D = E	$D = 3\frac{1}{4}$ " $\frac{25}{32}$ " + $3\frac{1}{4}$ " = E = $4\frac{1}{32}$ "	$D = \underline{\quad}$ " $C + D = E = \underline{\quad}$ "
E = distance from edge of template to edge of fence	Total = E = $4\frac{1}{32}$ "	Total = E = $\underline{\quad}$ "

\* Note: The example above reflects  $\frac{3}{4}$ " thick front/back and  $\frac{1}{2}$ " thick sides.

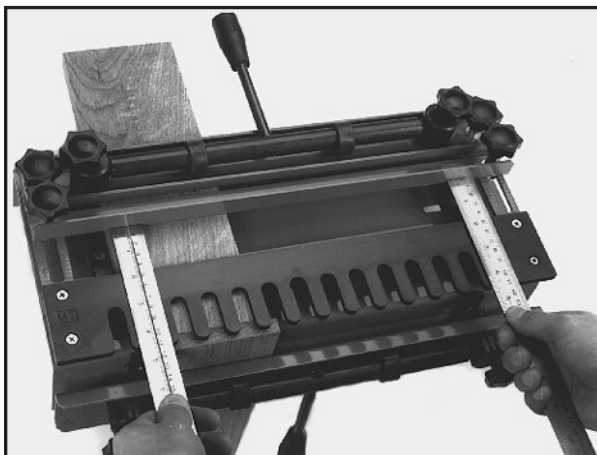

Figure 10 shows checking the alignment of the fence.

### IMPORTANT

When you have come up with a reliable number (E) for your router, base, bushing, and wood thickness combination, record it here and keep it for future reference. E will be different for different wood thicknesses.

---

## XIII. OPERATIONS

---

Your router base must accept a guide bushing with a  $\frac{7}{16}$ " outside diameter and an inside diameter large enough to accept a  $\frac{1}{4}$ " shank dovetail bit. Securely mount the guide bushing to your router.

Refer to your router's operating manual for further instructions.

Choose a  $\frac{1}{2}$ "  $14^\circ$  Dovetail router bit with a  $\frac{1}{4}$ " shank. Ensure that the router is unplugged. Securely mount the bit in the router collet.

Set the router bit to extend  $\frac{17}{32}$ " below the base

plate of the router.

Before cutting tails and pins in a finish piece, it is important to test your adjustments with sample pieces to judge the quality of the joint. It may be necessary to make additional adjustments to the dovetail jig to improve the fit. With the jig completely adjusted, you should be ready to test it out. Review all safety guidelines on Page 2 if you are not sure about the risks associated with operating a router in conjunction with this jig.

### A. REGULAR USE

To use the dovetail jig:

1. Start with joint 1 that you set up in Section VII.
2. Position the mated pieces in the jig so the insides face out and up. Each piece must be tight against the side stops. The back piece is positioned horizontally on top of the jig. The mating side piece positioned vertically in the front of the jig. Secure the drawer pieces with the clamps. The end of the side piece must be flush with the top face of the back piece. Figure 11.

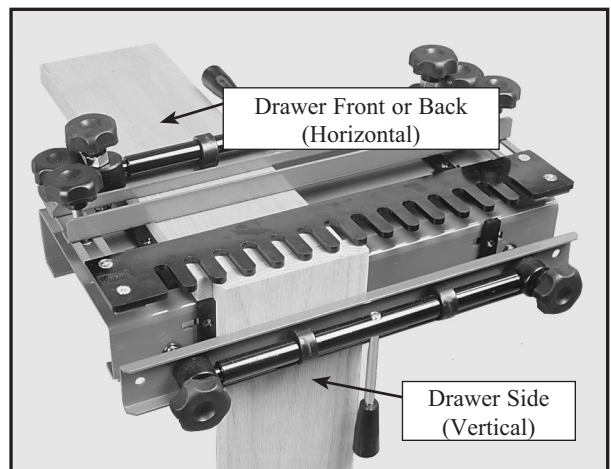

Figure 11 shows the dovetail jig set up for use. The inside faces of the boards are showing.

### TIPS FOR OPTIMUM RESULTS

Add  $\frac{1}{16}$ " to the distance between the template and the router fence to ensure a deep enough cut.

Don't clamp your work down too tight. Over-clamping tends to lift the wood on the front side of the jig.

Maintain steady, even pressure on the router when cutting. Remove materials in several smaller passes, rather than one large pass. This will lessen the chances of damaging your project or your router bit.

Use pieces of scrap wood the same thickness as your workpieces to provide an even base for the template and clamping mechanisms. Place them at the opposite end of the template and clamps before tightening the jig.

Be sure the template is sitting flat across the length of your workpiece before routing to ensure even cut depth.

---

## XIII. OPERATIONS

---

3. The router base and bit must be secure before plugging in your router. Hold the router firmly with both hands and support it on the template. Make sure that the bit is clear of the workpiece.

Turn the router on and gently ease the bit into the work, letting the guide bushing gently contact the template. Facing the dovetail jig, start at your left side and work to the right, following each template finger in and out. Ensure that the router base and guide bushing stay in firm contact with the template. Figure 12.

Hint: If you are using material thicker than  $\frac{7}{8}$ ", cut it in two stages. First, remove the material IN FRONT OF the fingers. Second, remove the material BETWEEN the fingers.



Figure 12 shows using the dovetail jig.

Use care when the router bit exits the workpiece to reduce the risk of tear-out. See section XIV.A. for further instructions.

4. Remove both pieces from the jig and join the dovetails.
5. It may be necessary to tap the two pieces together with a hammer and wood block. If alignment is so poor that the two pieces will not fit together, line up each piece as much as possible and determine the direction and degree of fine adjustment.

If the two pieces do not fit, it is usually because they were not milled square or the pieces were not flush with each other in the jig. See Section XIV.

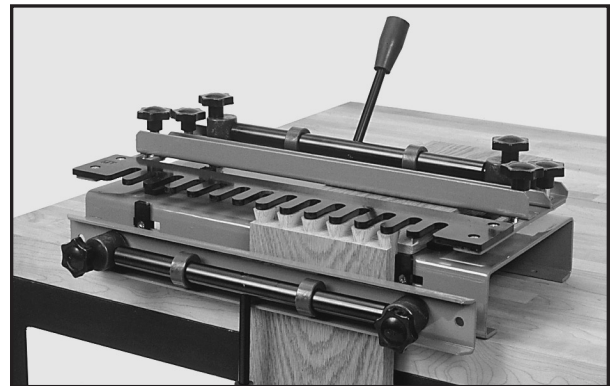

Figure 13 shows dovetails after cutting.



Figure 14 shows a finished drawer and 2 sides ready to be joined.

---

## XIII. OPERATIONS

---

### B. RABBETED DRAWER FRONTS

Drawer fronts that have been rabbeted around the inside edge to create a lip to restrict drawer travel in the closed position require some additional setup.

To produce half-blind dovetails on rabbeted drawer fronts:

1. A spacer must be added to the vertical side stop in the front of the jig to compensate for the rabbet. The width of the spacer must be the same width as the rabbet. Figure 15.
2. The fence must also be set back an additional amount equal to the width of the rabbet.
3. Since the side piece is unsupported by the front piece (the rabbet created a void behind the side piece), it is likely that the router bit will cause tear out each time the bit exits the side piece. To prevent tear out, place a wood spacer cut to the same dimensions as the rabbet for back-up support behind the top edge of the side piece.

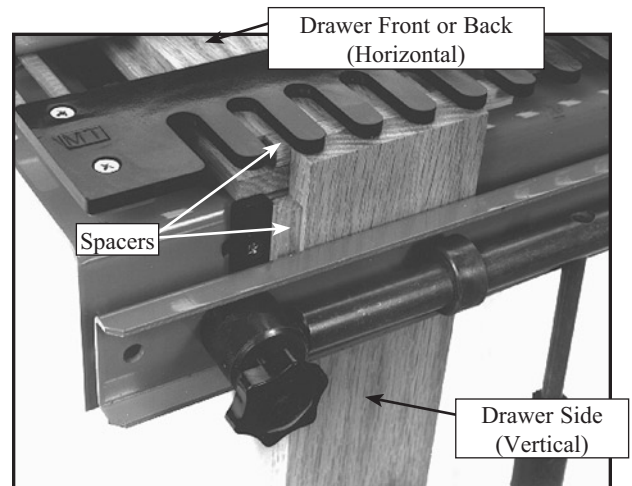

Figure 15 shows lining up a rabbeted board and where to locate the spacers to prevent tear-out. Section XIV.  
A.

---

## XIV. TROUBLESHOOTING

---

### A. TEAR-OUT

When cutting across the grain of the wood, tear-out or splintering may occur when the router bit exits the workpiece. To prevent tear-out, you may scribe a line on the side piece with a sharp knife or awl at the same distance down that router bit will cut. Tear-out can be eliminated or reduced by backing up the workpiece with a scrap piece or simply using extra care when operating the router.

### B. EXCESSIVE FIT

If the pins on the side piece fit too deeply in the tails of the front or back piece, the cut is too deep. Figure 16.

Cause: The distance between the edge of the side piece and fence is set too wide.

Remedy: Adjust the fence forward by the same amount that the pins are exposed. Refer to the procedure described above for fence adjustment.

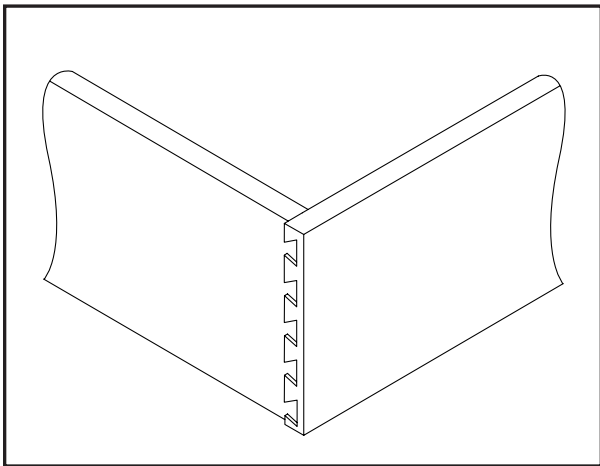

Figure 16 shows excessive fit.

### C. INCOMPLETE FIT

An incomplete fit occurs when the side piece protrudes from the end of the front or back piece. Figure 17.

Cause: The distance between the edge of the side piece and fence is set too narrow.

Remedy: Adjust the fence toward the back of the jig by the same amount that the tails protrude out.

To adjust the fence:

1. Make a reference line indicating the current position of the fence either on a piece of masking tape located on the jig or on the sample piece clamped under the fence.
2. Measure the distance that the tails protrude.
3. Loosen the fence locking knobs and slide the fence toward the back of the jig by the same distance.
4. Ensure that the fence is parallel to the edge of the workpiece and tighten the lock knobs.

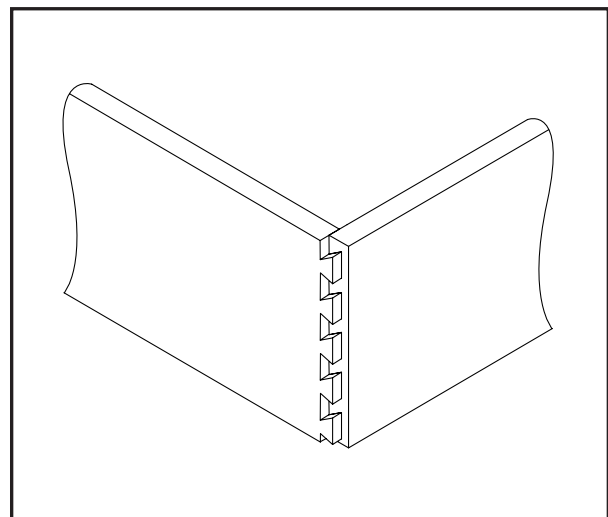

Figure 17 shows incomplete fit.

---

## XIV. TROUBLESHOOTING

---

### D. OFFSET EDGES

If the side piece edge is not aligned with the front or back piece edge, the edges are offset. Figure 18.

Cause: The side stops are not set correctly.

Remedy: Measure the amount of offset on the two test pieces and adjust the front side stop accordingly. The front side stop must be offset from the top side stop by the exact width of the fingers on the template you are using. Ensure that the front side stop remains square to the workpiece mounted

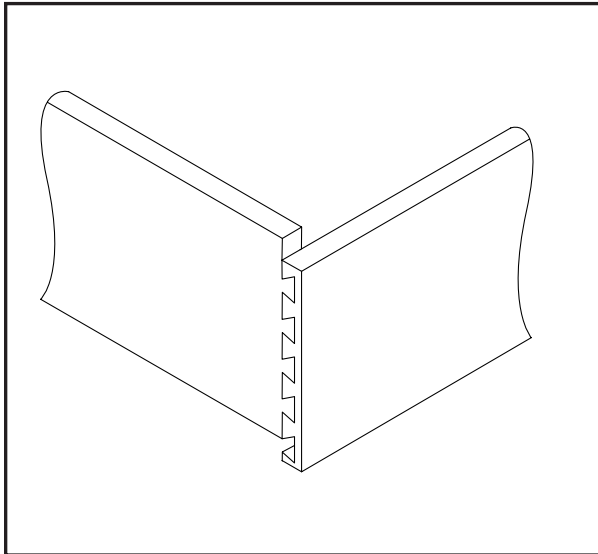

Figure 18 shows offset edges.

### E. FIT TOO TIGHT OR TOO LOOSE

If you find the fit to be about right in every other aspect, but it is simply a little too tight or too loose, the depth of the router bit is probably mal-adjusted.

1. If the fit is too tight, decrease the protrusion of the router bit from the base.
2. If the fit is too loose, increase the protrusion of the router bit from the base.

on top of the jig.

### F. UNEVEN FIT

If the side piece fits either excessively or protrudes at one edge and not the other, the fit is uneven. Figure 19.

Cause: The fence is not parallel to the edge of the workpiece or the template is not parallel to the edge of the workpiece.

Remedy: Adjust the fence or template in the desired direction until it is parallel to the edge of the workpiece. For the highest degree of accuracy, clamp the two workpieces in the front of the jig so they are positioned against the two side stops and measure the distance between the edge of the workpiece and the edge of the fence or template.

Adjust the fence or template so the measurement on the other end of the jig equals the first. Re-check the first measurement in case it changed during adjustment.

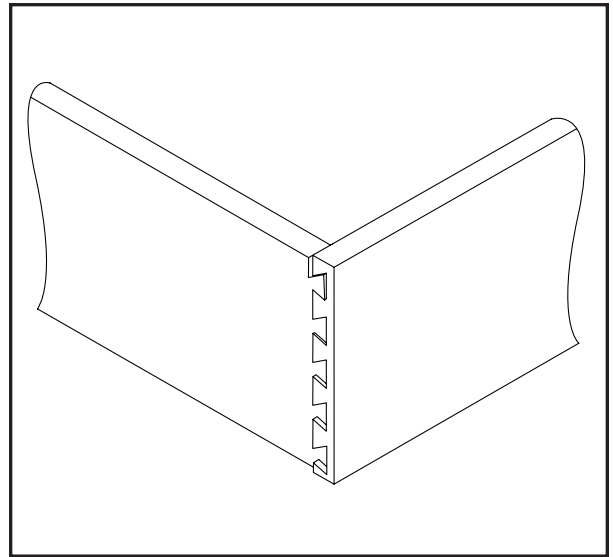

Figure 19 shows uneven fit.



---

## XV. WARRANTY

---

### LIMITED WARRANTY

Woodstock International, Inc. (Woodstock) warrants this product against defects in workmanship and materials under normal use and service for a period of one year. This warranty extends to the original purchaser from the date of purchase. This warranty does not apply to defects due directly or indirectly to misuse, abuse, negligence, accidents, repairs or alterations or lack of maintenance.

This is Woodstock's sole written warranty and any and all warranties that may be implied by law, including any merchantability or fitness, for any particular purpose, are hereby limited to the duration of this written warranty. We do not warrant or represent that the merchandise complies with the provisions of any law or acts. In no event shall Woodstock's liability under this warranty exceed the purchase price paid for the product and any legal actions brought against Woodstock shall be tried in the State of Washington, County of Whatcom.

We shall in no event be liable for death, injuries to persons or property or for incidental, contingent, special or consequential damages arising from the use of our products.

To take advantage of this warranty, the product or part must be returned to the original place of purchase. Proof of purchase must accompany the merchandise. Woodstock reserves the right to change specifications at any time since we constantly strive to achieve better quality equipment.

We make every effort to ensure that our products meet high quality and durability standards and we hope you never need to use this warranty.

---

---

## XVI. CLOSURE

---

The following pages contain general specifications, a parts diagram and list, and index for your Model W1099 Dovetail Jig.

If you need parts or help in assembling your jig, or if you need operational information, we encourage you to contact your dealer. He will be happy to help you.

If you have any parts problems or requests, please contact the dealer where the W1099 Dovetail Jig was purchased or call Woodstock International at 1-800-840-8420 between 8am and 5pm Pacific Standard Time, Monday through Friday.

If you have any comments or concerns dealing specifically with this manual, please write to our Bellingham, Washington location using the address listed in the Introduction.

---

# XVII. PARTS DIAGRAM

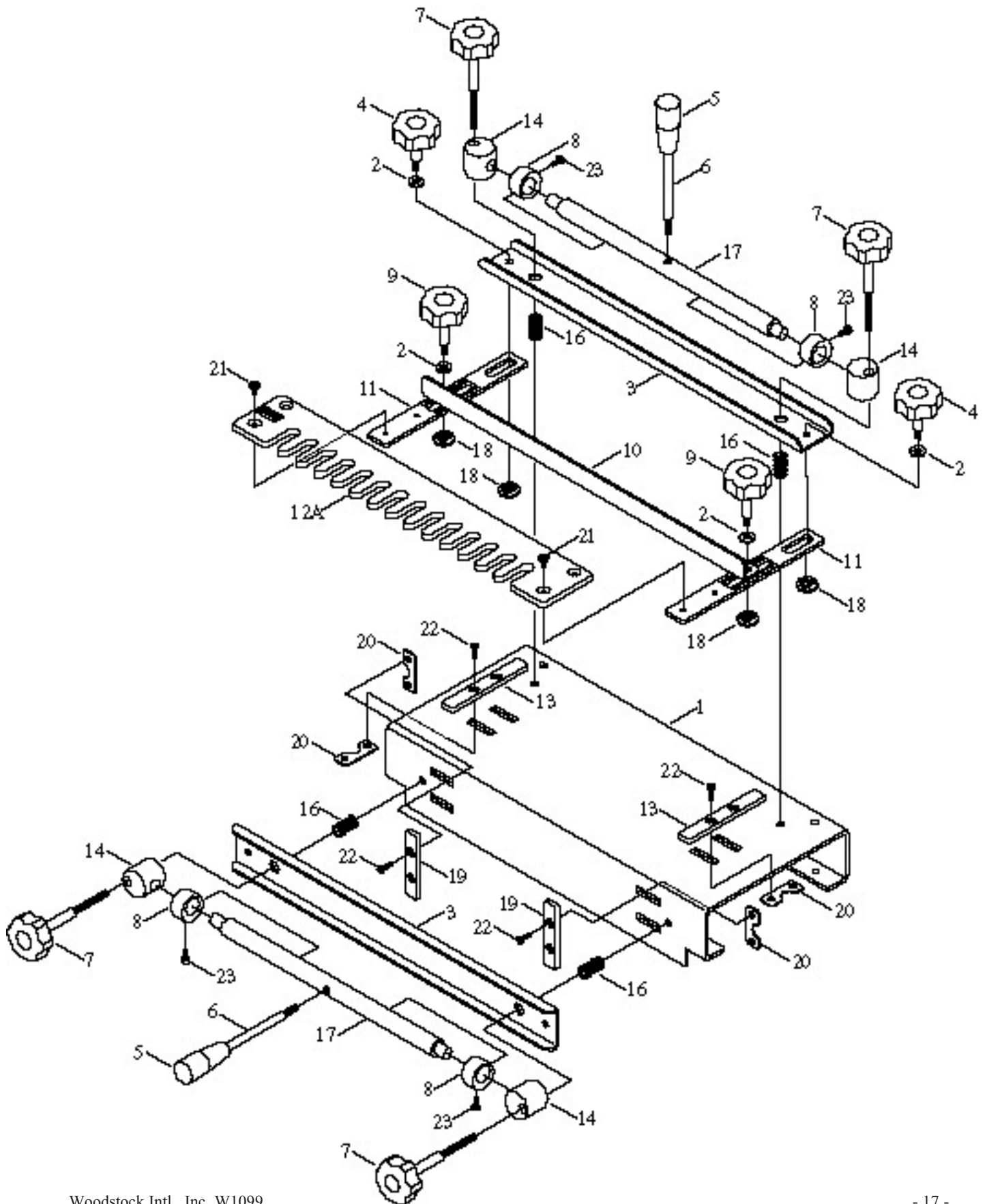

## XVIII. PARTS LIST

REF#	DESCRIPTION	REF#	DESCRIPTION
1	BASE	12B	TEMPLATE 7/16"
2	FLAT WASHER 5/16"	12C	TEMPLATE 9/16"
3	CLAMP	13	SIDE STOP, UPPER
4	TEMPLATE LOCK KNOB	14	HUB
5	LEVER	16	SPRING
6	TENSION LEVER ROD	17	CLAMPING ROD
7	TENSION KNOB	18	T-NUT
8	CAM	19	SIDE STOP, LOWER
9	FENCE LOCK KNOB	20	RETAINER PLATE
10	FENCE	21	FLAT HD SCREW M6-1.0 x 8
11	BRACKET	22	FLAT HD SCREW M5 - 0.8 x 15
12A	TEMPLATE 1/2"	23	PHLP HD SCREW M5 - 0.8 x 12

## XIX. TOOL DATA

### W1099 DOVETAIL JIG

**Overall Dimensions:**

Height..... 6"  
 Width ..... 17"  
 Depth..... 12"  
 Shipping Weight ..... 22 lbs.  
 Weight in Place..... 20 lbs.

**Capacity:**

Material Thickness, sides ..... 5/16" to 1 1/4"  
 Material Thickness, front and back ..... 5/8" to 1 1/4"  
 Maximum Width..... 12"  
 Joint..... 5/8" with 1/2" Template  
 Joint..... 1/2" with 7/16" Template  
 Joint..... 3/4" with 9/16" Template

**Construction:**

Jig..... Pre-Formed Steel  
 Clamps ..... Single lever Adjustable Cam  
 Template ..... Phenolic Plastic

**Router Specifications:**

Maximum Router Base Size ..... 7"  
 Router Bit Required..... 14°, 1/2" Dovetail with 1/4" Shank  
 Guide Bushing Required ..... 7/16" O.D.

Specifications, while deemed accurate, are not guaranteed.

---

## XX. INDEX

---

<b>A</b>	
Address .....	1
Adjustment Locations .....	5
Assembly.....	3
<b>B</b>	
Base, size .....	4
Bit depth.....	4
Bit, size .....	4
<b>C</b>	
Capacities.....	4
Clamp Adjusting.....	6
Closure .....	15
Commentary.....	1
<b>E</b>	
Excessive Fit.....	13
<b>F</b>	
Fence Adjustment .....	9
Fit too Loose .....	14
Fit too Tight .....	14
<b>G</b>	
Guide Bushing .....	4
Tool Data .....	15
<b>H</b>	
Half-blind dovetails .....	4
Hand Lever Assembly .....	3
<b>I</b>	
Incomplete Fit.....	13
Introduction.....	1
Items List .....	3

<b>M</b>	
Material, size.....	4
Mounting.....	3
<b>O</b>	
Offset Edges.....	14
Operations .....	10-12
<b>P</b>	
Parts Diagram .....	16
Parts List .....	17
Pin Depth .....	4
Pin Width .....	4
Preparation .....	4
<b>R</b>	
Rabbeted Drawer Fronts.....	12
Regular Use.....	10-11
<b>S</b>	
Safety Rules for all Tools .....	2
Side Stop Set Up.....	6-7
<b>T</b>	
Tear Out .....	13
Template Adjustment.....	8
Template Sizes.....	4
Tool Data .....	17
Troubleshooting .....	13-14
<b>U</b>	
Uneven Fit.....	14
Unpacking.....	3
<b>W</b>	
Warranty and Returns .....	15

# NOTES