

## Originalbetriebsanleitung

- D -	Betriebsanleitung	2
- GB -	Operating manual	32
- F -	Mode d'emploi	61
- NL -	Gebruikshandleiding	90

## Plast Coat 430

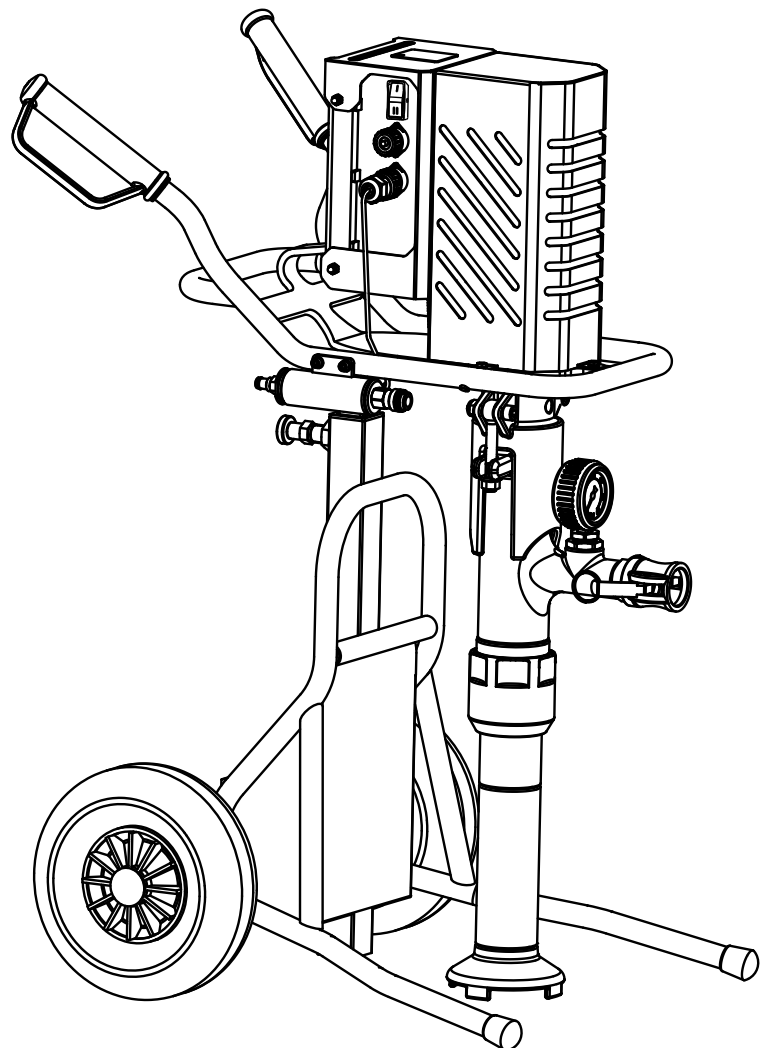

Translation of the original operating instructions

# Warning!

**Mortar spraying machines develop high spraying pressures.**

	<p><b>Attention – Danger of injury!</b></p>
<p>①</p>	<p><b>Never reach into the spray jet with your fingers or hand!</b>  <b>Never point the spray lance at yourself or other persons!</b>  <b>Coating materials are caustic or irritating!</b>  <b>Protect your skin and eyes!</b></p>
<p>②</p>	<p><b>The following points are to be observed in accordance with the operating manual before every start-up:</b></p> <ol style="list-style-type: none"> <li>1. Observe the permissible pressures.</li> <li>2. Check all the connecting parts for leaks.</li> </ol>
<p>③</p>	<p><b>Instructions for regular cleaning and maintenance of the machine are to be observed strictly.</b>  <b>Observe the following point before any work on the machine and at every working break:</b></p> <ol style="list-style-type: none"> <li>1. Observe the curing time of the coating material.</li> <li>2. Depressurize the spray lance and mortar hose.</li> <li>3. Switch off the suction pump.</li> </ol>

## Ensure safety!

## Table of Contents

<b>1</b>	<b>SAFETY REGULATIONS</b>	<b>34</b>	<b>9</b>	<b>MAINTENANCE</b>	<b>49</b>
<b>2</b>	<b>INTRODUCTION TO WORKING WITH THE MORTAR SPRAYING MACHINE PLASTCOAT 430</b>	<b>36</b>	9.1	Mechanical maintenance	49
2.1	Function of the mortar spraying machine PlastCoat 430	36	9.2	Electrical maintenance	49
2.2	Processible coating materials	36	9.3	Long periods of non-usage	49
<b>3</b>	<b>TECHNICAL DATA</b>	<b>36</b>	9.4	Rotor replacement	49
<b>4</b>	<b>EXPLANATORY DIAGRAM FOR PLASTCOAT 430</b>	<b>37</b>	<b>10</b>	<b>ELIMINATING FAULTS</b>	<b>50</b>
4.1	Operating elements and displays on device	38	<b>11</b>	<b>SPARE PARTS LIST FOR PLASTCOAT 430</b>	<b>53</b>
4.2	Drive	39	<b>12</b>	<b>SPARE PARTS LIST OF CARRIAGE</b>	<b>54</b>
4.3	Compressor (accessory)	39	<b>13</b>	<b>SPARE PARTS LIST OF SPRAY LANCE WITH AUTOMATIC CONTROL</b>	<b>55</b>
4.4	Mortar hose for pneumatic spray lance	39	<b>14</b>	<b>SPARE PARTS LIST PNEUMATIC SPRAY LANCE</b>	<b>56</b>
4.5	Pneumatic spray lance	39	<b>15</b>	<b>PLASTCOAT 430 ACCESSORIES</b>	<b>57</b>
4.6	Mortar hose for automatic spray lance	40		Testing of the mortar spraying machine	59
4.7	Automatic spray lance	40		Note on disposal	59
<b>5</b>	<b>TRANSPORTATION</b>	<b>41</b>		Important information on product liability	59
5.1	Moving	41		Guarantee declaration	59
5.2	Transportation in vehicle	41		CE declaration of conformity	119
<b>6</b>	<b>COMMISSIONING</b>	<b>42</b>		European service network	120
6.1	Installation location	42			
6.1.1	Connection to mains power supply/ Extension cable	42			
6.2	Initial starting-up	42			
6.2.1	Scope of supply	42			
6.2.2	Assembly	42			
6.3	Connecting the mortar hose	43			
6.4	Compressor (accessory)	43			
6.5	Connecting the spray lance	43			
6.6	Remote control (accessory)	44			
6.6.1	Remote control assembly	44			
6.7	Preparing the mortar spraying machine	45			
6.8	Beginning of the spraying process	46			
6.9	End of the spraying process	46			
<b>7</b>	<b>GENERAL INFORMATION ABOUT THE APPLICATION TECHNIQUE</b>	<b>47</b>			
7.1	Spraying technique	47			
<b>8</b>	<b>SHUTTING DOWN AND CLEANING</b>	<b>47</b>			
8.1	Cleaning the mortar hose	47			
8.2	Cleaning the device and replacing the stator	47			
8.3	Cleaning the spray lance	49			

## 1 SAFETY REGULATIONS

The following sources are just a sample of those containing safety requirements for mortar conveyors:

- Working reliability regulation, accident prevention regulation "Fundamental principles of prevention"** (BetrSichV, BGV A1) **including explanations and details of BGR A1 (Occupational Safety Regulations)**
- BG 183, Occupational Safety Regulation of the Berufsgenossenschaft der Bauwirtschaft (The statutory accident and insurance prevention institution in the building trade in Germany), mortar conveyors and mortar spraying machines**
- DIN EN 12001: 2004-05, Conveying, spraying and placing machines for concrete and mortar - Safety requirements; German version; German version EN 12001:2003**

The following specifications are to be observed in particular to handle mortar spraying machines safely:

### Usage of the mortar spraying machine

The mortar spraying machine PlastCoat 430 may only be used to process the coating materials described on page 36. **Any other usage is not allowed.**

Proper usage also includes the observance of the operating manual and the observance of the inspection and maintenance conditions. Always keep the operating manual on hand at the point of use of the mortar spraying machine.

The mortar spraying machine PlastCoat 430 may only be operated with a manometer. Only the mortar hose specified by the manufacturer may be used.

Use only marked mortar hoses with at least 40 bars operating pressure.

### Protection of persons

In order to protect eyes, skin and the respiratory organs: **Wear safety goggles, protective clothing, gloves, possibly use protective skin cream and respiratory equipment.** Do not decouple the mortar hose as long as it is under pressure. Watch the manometer! Wear safety goggles! Do not point the spray lance at persons!

In order to protect your ears **wear ear protection.**

Wear safety shoes when transporting the machine or working with it.

People not needed to assist with machine installation, assembly or operation, must keep away from the machine.

The PC 430 is equipped with an EMERGENCY STOP switch for emergencies.

### Breathing masks

Make a breathing mask available to the processor in order to protect against mineral dust. Refer to the regulations of the German employer's liability insurance association ("Berufsgenossenschaft") "Rules for the use of breathing masks" (BGR 190) and "Processing coating materials" (BGV D25).

**Connection to the mains network only via a special feeding point, for example via a distribution board for construction sites, with residual current protective device with INF ≤ 30 mA.**

**Avoid soiling of the socket for the remote control at the control unit.**



**Risk of injury from escaping material. Before switching on, always check that the material tap on the spray lance is closed. Close material tap whenever stopping work.**



**Risk of crushing when adjusting height of holder and connecting material hose. Never operate mortar spraying machine with an exposed rotor. Do not reach into the rotor when it is moving. Risk of crushing. Caution if you have long hair. Only wear close-fitting clothes at work.**

### Cleaning and maintenance

Never decouple mortar hose or disassemble machine when under pressure. Note pressure reading on pressure gauge.

When performing maintenance work, always switch off mortar spraying machine, disconnect mains plug and ensure it cannot be plugged back in by mistake.

Do not spray down the motor and control unit of the mortar spraying machine with a water-jet, high-pressure cleaner or high-pressure steam cleaner. Danger of short-circuits caused by water ingressing.

### Electrical equipment

Work on the machine's electrical equipment may be carried out only by a qualified electrician. The electrical equipment is to be checked regularly. Eliminate faults such as loose connections or scorched cables.

**Keep the label on the mortar spraying machine clean and legible.**



**Whenever the machine is automatically brought to a standstill or during power failure, immediately move the selector switch to "A" to prevent the machine starting back up again unintentionally. There is a danger of injury.**

## Setup on an uneven surface

The mortar spraying machine must be installed as shown in the diagram below to prevent it slipping.

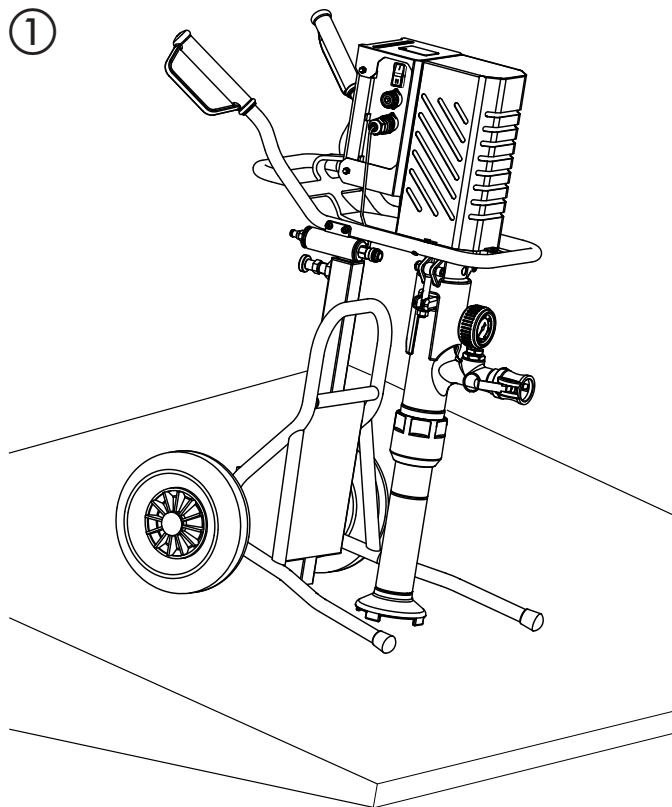

## 2 INTRODUCTION TO WORKING WITH THE MORTAR SPRAYING MACHINE PLASTCOAT 430

The suction pump PlastCoat 430 is conceived for using and processing ready mixed mineral coating materials from a bucket.

The material supply is ensured by the immersion of the suction tube into the material bucket.

The machine is not designed for use as a cleaning device.

### 2.1 FUNCTION OF THE MORTAR SPRAYING MACHINE PLASTCOAT 430

The coating material is fed through the suction effect of the screw pump. The suction effect causes the coating material to enter the eccentric screw pump. This pump builds up the pressure required for transportation through the mortar hose. The compressed air required for atomisation is supplied at the spray lance. The mortar spraying machine can be switched on and off using the electric control. This can also be used to control the delivery volume.

A soft even spray pattern can be achieved by means of the smoothly regulated convey capacity of the coating material.

### 2.2 PROCESSIBLE COATING MATERIALS

- Thermal insulation composite system bonding agent (mineral and artificial resin systems)
- Artificial resin plasters up to 3 mm granular size
- Silicate plasters up to 3 mm granular size
- Silicone resin plasters up to 3 mm granular size
- Mineral final coats up to 3 mm granular size
- Lightweight plaster systems up to 3 mm granular size
- Scraped stucco up to 3 mm granular size
- Thermal insulation plasters
- Restoration plaster
- Porous concrete coating
- Quartz plastic
- Roof coatings
- Fire protection coatings
- Mineral sealing sludges
- Bitumen emulsions
- Armoring filler
- Liquid wood-chip wall paper
- Casement grouting mortar
- Artificial resin rendering base
- Wash primer
- Filling paint, also fibrous
- Elastic coating
- Acoustic plaster, artificial resin bonded
- Fillers, artificial resin bonded

All the coating materials must be suitable for machine processing. Refer to the product data sheet of the coating material to be processed.

Use other coating materials only after agreement with the manufacturer or the WAGNER application technology service.

## 3 TECHNICAL DATA

	<b>PlastCoat 430</b>
Voltage:	230 V~, 50 Hz
Fusing:	16 A time-lag
Device supply cable:	5 m long, 3 x 1.5 mm <sup>2</sup>
Motor output P <sub>i</sub> :	1.8 kW
Max. convey capacity (water):	12 l/min
Max. operating pressure:	40 bar
Max. granular size:	K3 mm
Dimensions L x W x H:	700 x 600 x 1050 mm
Weight:	38 kg
Max. tyre pressure:	2.5 bar
Degree of protection:	IP 55
Max. sound pressure level:	70 dB (A)*
Atomizing air connection:	Rapid action coupling DN 7.2 mm
Max. atomizing air pressure:	10 bar
Minimum required compressed air volume:	280 l/min
Max. mortar hose length:	30 m (and 2.5 m hose whip)
Max. delivery height:	20 m

\* Place of measurement: 1 m distance from unit and 1.60 m above reverberant floor.

## 4 EXPLANATORY DIAGRAM FOR PLASTCOAT 430

- |    |  |    |   |
|----|--|----|---|
| 1  | Drive and control unit complete  | 2  | Base frame with wheels  |
| 3  | Operating light green (indicates that mains voltage is present)                      | 4  | Indicator light red (indicates the presence of a malfunction) |
| 5  | Control panel with selector switch for operating mode and delivery volume controller | 6  | EMERGENCY STOP switch   |
| 7  | Suction tube with inside screw pump  | 8  | Manometer   |
| 9  | Connecting coupling for mortar hose  | 10 | Mortar hose with air hose complete                            |
| 11 | Spray lance  | 12 | Special key   |
| 13 | Suction flange   | 14 | Storage box   |
| 15 | Magnets for fixing locking pins  | 16 | Spray lance air hose connection (pneumatic version only)      |
| 17 | Lock   | 18 | Compressor air hose connection (pneumatic version only)       |
| 19 | Hose / cable holder  | 20 | External controller connection                                |
| 21 | Remote control connection  | 22 | Switch for activating remote control                          |

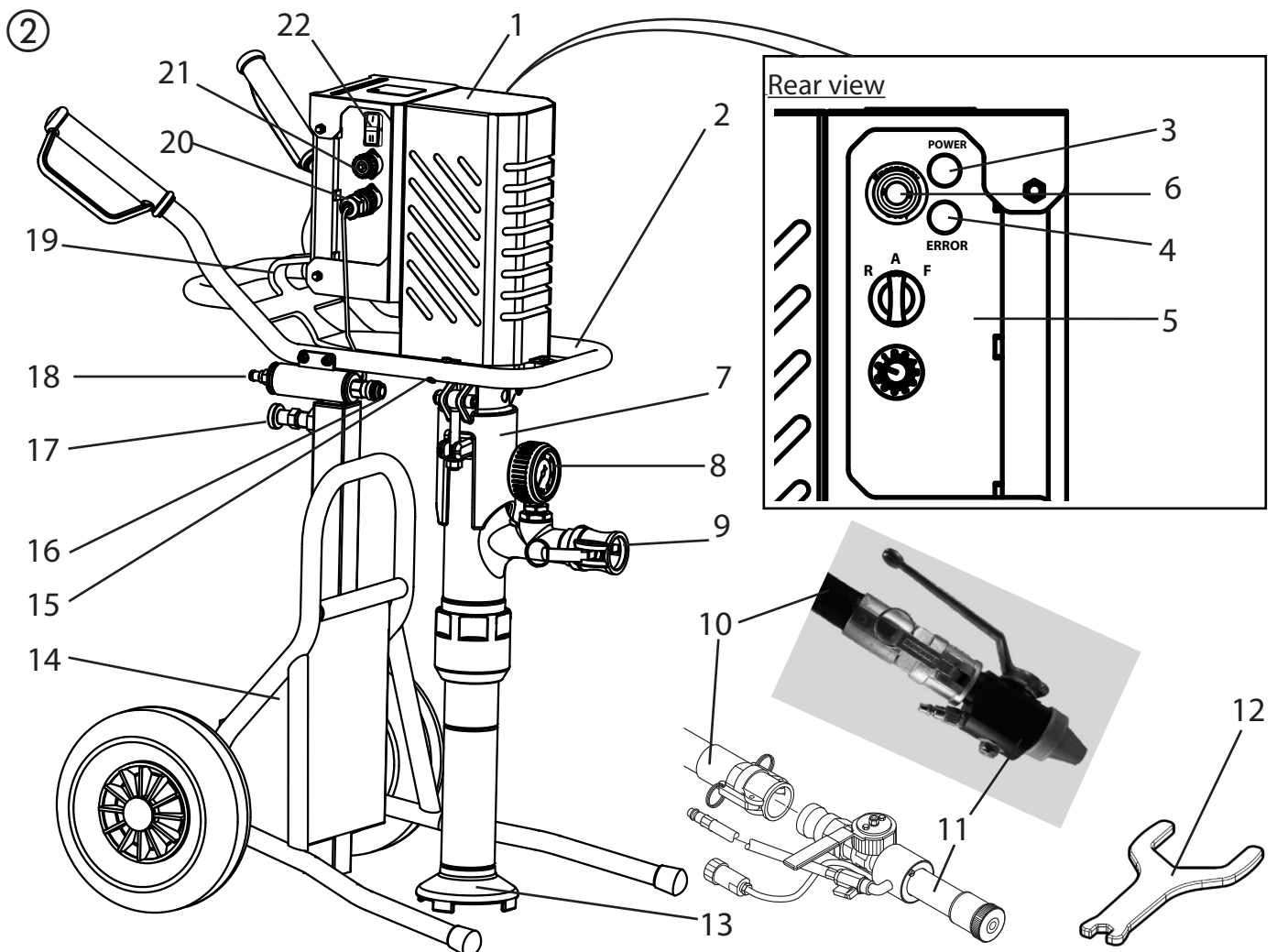

**4.1 OPERATING ELEMENTS AND DISPLAYS ON DEVICE**

- 1 Delivery volume controller 0-10
- 2 Selector switch for operating mode
- 3 Indicator light (Error)
- 4 Operating light (Power)
- 5 EMERGENCY STOP switch
- 6 Switch for activating remote control

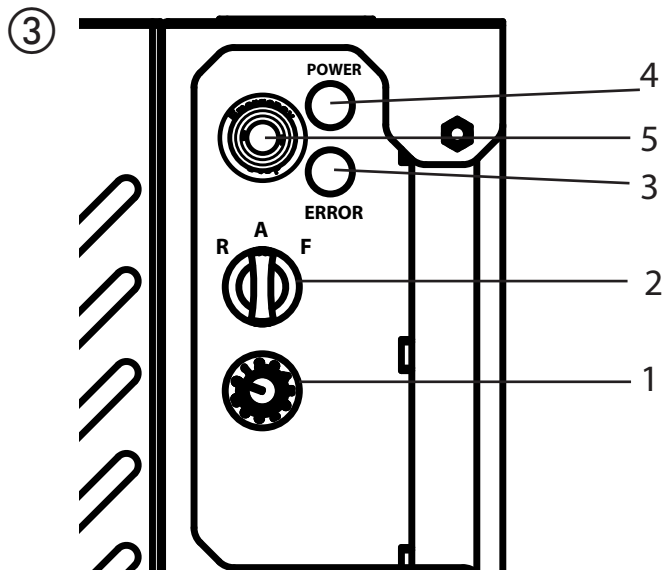

Rear view

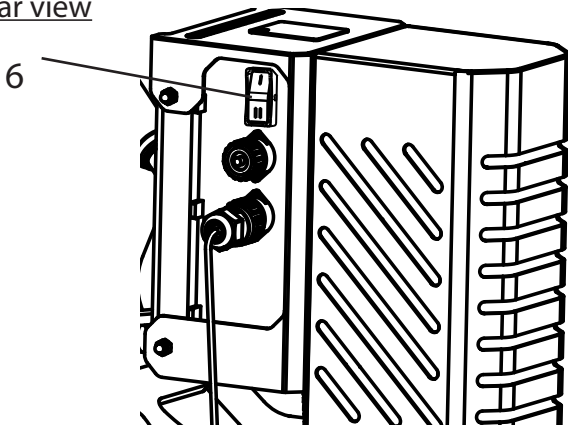

The delivery volume controller (Fig. 3, 1) is used to regulate the convey capacity from 0-10 smoothly.

	The remote control (available separately, art. no. 2308 417) can be used to conveniently control the pump's delivery volume from the spray lance.
--	---

The selector switch (Fig. 3, 2) offers the following modes:

	<p>"A" position = automatic Basic setting for control with an automatic spray lance, pneumatic spray lance or remote control</p>
	<p>"F" position = manual activation Switches on the mortar spraying machine. This setting is required for:</p> <ul style="list-style-type: none"> <li>• suction unit assembly</li> </ul> <p>When using the pneumatic lance, this setting is also needed for:</p> <ul style="list-style-type: none"> <li>• pre-rinsing the mortar hose to improve the material's ability to slide</li> <li>• cleaning</li> </ul>
	<p>"R" position = reverse gear (must be held in this position). This setting is required for:</p> <ul style="list-style-type: none"> <li>• relieving pressure on the mortar hose</li> <li>• suction unit disassembly</li> </ul>

**Detailed explanation of selector switch use:**

If the selector switch is in the "A" position, the PC430 can be switched on and off with the material shut-off on the automatic or pneumatic spray lance.

If there is no spray lance fitted (e.g.: assembly/disassembly of suction unit), the machine is switched on using the "F" switch position and off using the "A" position.

Since the air supply through the compressor needs to be switched off to clean the mortar hose, the pneumatic lance is not controlled using the material shut-off. In this case, the machine must therefore also be switched on using the "F" position.

	<p>Important: control via the selector switch and material shut-off are treated equally. The machine can be switched from the "A" position (control using material shut-off) to "F" at any time. We would therefore recommend that only one person operate the machine.</p>
--	---

The operating light (green, Fig. 3, 4) indicates that the machine is energised and ready.

The indicator light (red, Fig. 3, 3) indicates a fault. For detailed information about this kind of fault, refer to the „Rectification of faults“ section on page 50.

The switch (Fig. 3, 6) allows you to switch between internal and external control. In Position "I", the PC 430 is controlled with the integrated control panel. In Position "II" it is controlled with the remote control.



**i** If the selector switch is in the "F" position when the mains plug is plugged in, the machine will not switch on.  
Briefly move selector switch to "A" and then back to "F" to switch on the machine.

### EMERGENCY STOP switch

When the EMERGENCY STOP switch is pressed, the PC 430 is switched off immediately.

Turn the EMERGENCY STOP switch in order to release it again. The machine remains switched off after release. To switch it on again, the selector switch must be briefly set to "A" and then to "F".

### 4.2 DRIVE

When an overload occurs, the mortar spraying machine switches off automatically (red indicator light lights up).

Move selector switch (Fig. 3, 2) to "A" and disconnect mains plug. Set delivery volume controller (Fig. 3, 1) to „0“.

Wait around 5 minutes, then plug the mortar spraying machine back in and switch on. Set the delivery volume required.

**i** The drive unit heats up during operation. This is normal and not a sign of malfunction.

### 4.3 COMPRESSOR (ACCESSORY)

VKM 592 intake volume 590 l/min

**Note:**

Only operate the compressor in accordance with the enclosed operating manual.

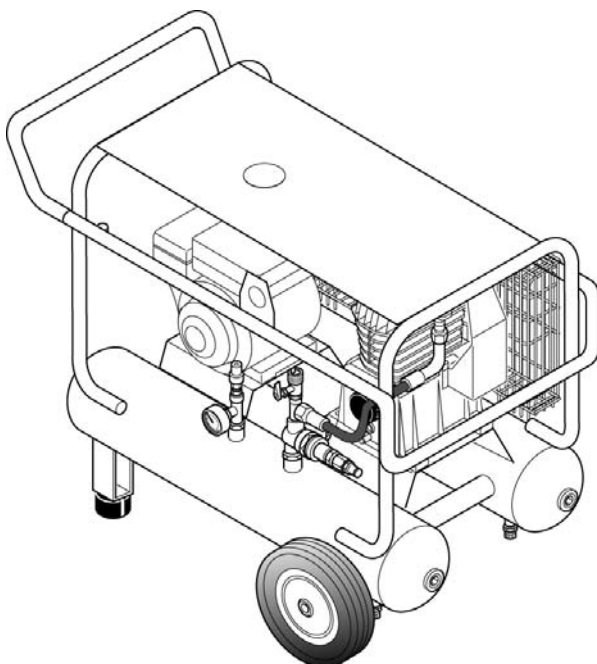

### 4.4 MORTAR HOSE FOR PNEUMATIC SPRAY LANCE

- 1 Material connection mortar spraying machine
- 2 Atomizing air connection compressed air supply
- 3 Material connection spray lance
- 4 Mortar hose
- 5 Atomizing air connection spray lance

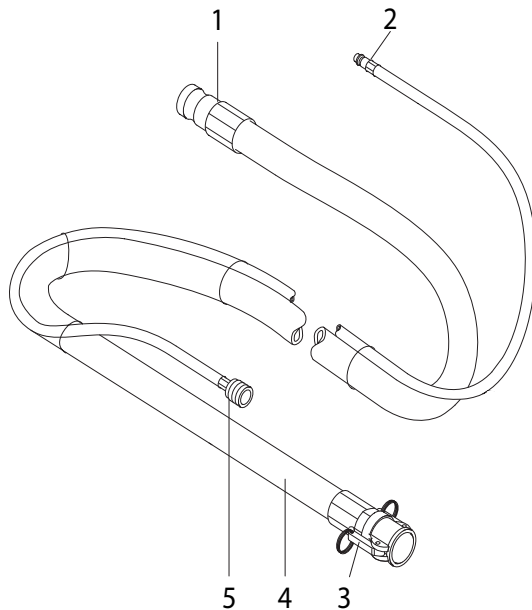

### 4.5 PNEUMATIC SPRAY LANCE

- 1 Atomizing air connection
- 2 Texture tip
- 3 Combined material and air tap  
Open: material tap at 90° to spray lance  
Closed: material tap facing to the rear
- 4 Material connection

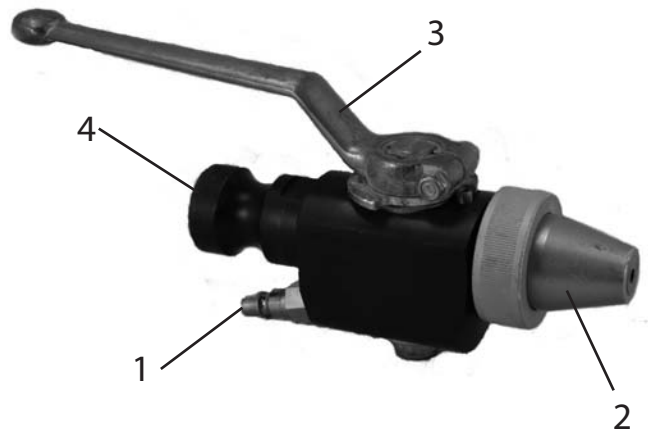

Various texture tips can be used in the spray lance. The tip size depends on the granular size of the coating material and the desired spray pattern.

OVERVIEW

**4.6 MORTAR HOSE FOR AUTOMATIC SPRAY LANCE**

- 1 Material connection mortar spraying machine
- 2 Control cable connection / controller
- 3 Atomizing air connection compressed air supply
- 4 Material connection spray lance
- 5 Mortar hose
- 6 Atomizing air connection spray lance
- 7 Control cable connection/ automatic spray lance

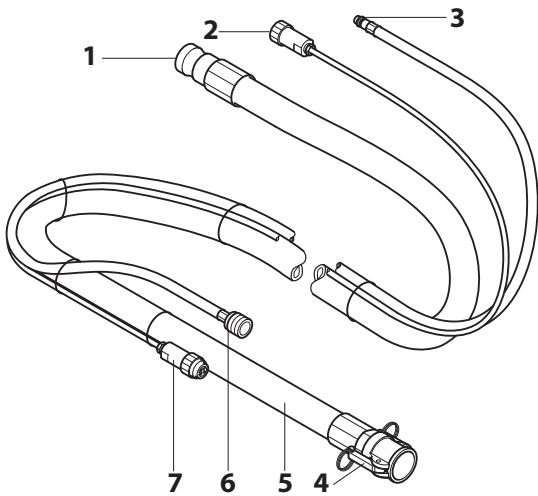

**4.7 AUTOMATIC SPRAY LANCE**

- 1 Material connection
- 2 Switch sleeve, switching the mortar spraying machine on and off using control cable
- 3 Texture tip
- 4 Air tap
- 5 Material tap
- Open: material tap facing to the rear
- Closed: material tap at 90° to spray lance
- 6 Control cable connection
- 7 Atomization air connection

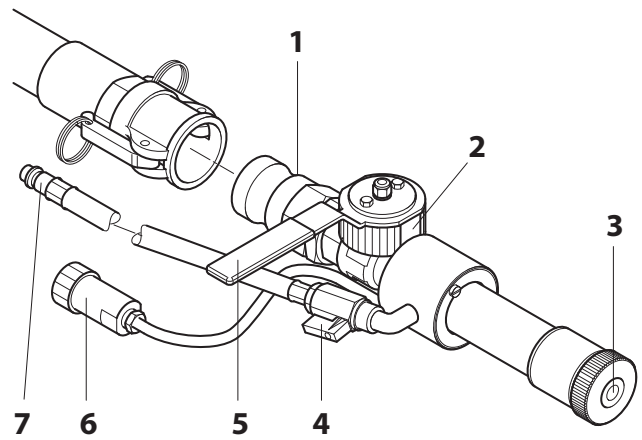

Various texture tips can be used in the spray lance. The tip size depends on the granular size of the coating material and the desired spray pattern.

## 5 TRANSPORTATION

### 5.1 MOVING

Pull safety pin (1) to rear and press down on mortar spraying machine frame (2) until machine engages in the centre position.

Roll up mains cable on cable bracket (3) and remove hose. Tip PC 430 towards rear using handle (4) so it can be easily pulled or pushed by hand.



**The machine must not be transported with a crane.**

### 5.2 TRANSPORTATION IN VEHICLE

Pull safety pin (1) to rear and press down on mortar spraying machine frame (2) until machine engages in the bottom position.

Secure the unit in the vehicle by means of suitable fasteners.



To prevent material residue from escaping from the suction tube, clean machine in advance or seal suction tube.

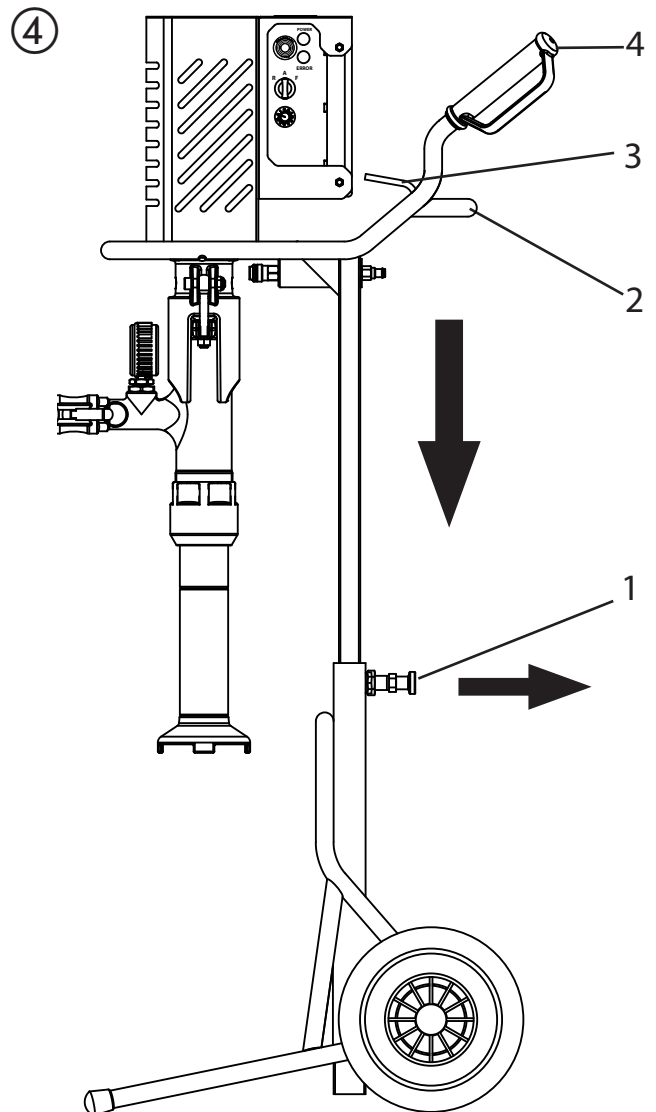

## 6 COMMISSIONING

### 6.1 INSTALLATION LOCATION

The mortar spraying machine and the bucket from which the material to be processed is to be pumped have to be set up on an even and firm underground. This ensures that the machine and bucket cannot slide away or fall over.

#### 6.1.1 CONNECTION TO MAINS POWER SUPPLY/ EXTENSION CABLE

**Connection to the mains network only via a special feeding point, for example via a distribution board for construction sites, with residual current protective device with INF ≤ 30 mA.**

	<p>Lay the device supply cable so that there is no danger of stumbling. Protect against damage, for example against being driven over.</p>
--	--

	<p>Min. wire cross-section 3 x 1.5 mm<sup>2</sup>. Unroll the extension cable completely. Ensure that the coupling pieces and plugs are free of damage.</p>
--	---

- Before connecting the unit to the mains supply, ensure that the line voltage matches that specified on the rating plate.

### 6.2 INITIAL STARTING-UP

#### 6.2.1 SCOPE OF SUPPLY

The machine is supplied by the manufacturer in the following individual components:

- Complete basic machine comprising drive unit, control unit and transport frame with wheels
- Pump unit complete
- Tool : Special key
- Hose package
- Spray lance
- Pump sliding means

#### 6.2.2 ASSEMBLY

Pull safety pin (1) to rear to release lock. Pull PC430 up by its frame (2) until the machine engages in the top position. Spray rotor (3) with a suitable pump lubricant (order no. 9992 824).

Move selector switch (4) to "A" and set delivery volume controller (5) to „0“.

Connect mains plug to mains power supply.

The operation light (6) shows operational readiness.

Fold locking pins (7) up towards the magnet holders in the handle to prevent them being twisted during assembly.

	<p><b>Only the person controlling the machine may assemble the pump unit. Never operate mortar spraying machine with an exposed rotor. Do not reach into the rotor when it is moving. Risk of crushing. Caution if you have long hair. Only wear close-fitting clothes at work.</b></p>
--	---

Slide pump unit (8) over rotor (3) from below and press upwards.

Set delivery volume controller (5) to 1 or 2.

Set selector switch (4) to "F" to switch on pump. The pump unit is automatically drawn up by the rotor.

As soon as the pump unit is in its end position, fold the two locking pins (7) down and use nuts to fix the pump unit.

	<p>If necessary rotate pump unit (8) by hand to move locking pins (7) into end position.</p>
--	--

Set selector switch (4) to "A" to switch off pump.

Disconnect mains plug.

	<p>After assembling the pump unit, secure the union nut (9) on the pump unit, using the special key to do so.</p>
--	---

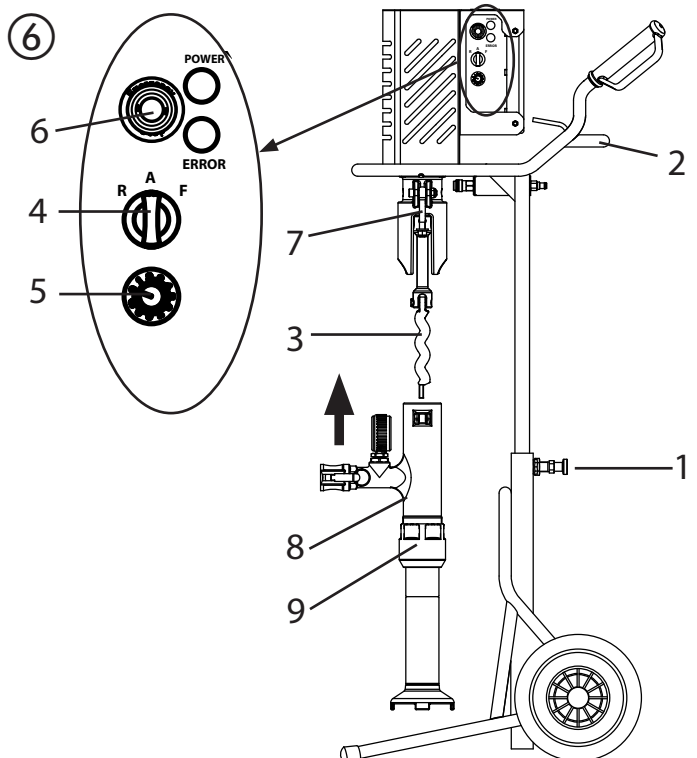



**AUTOMATIC SPRAY LANCE**

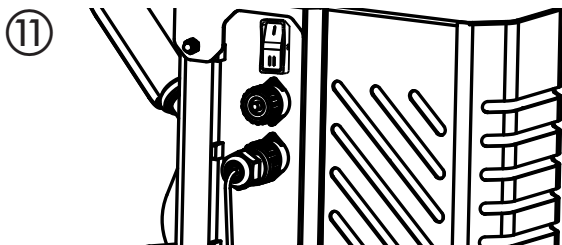
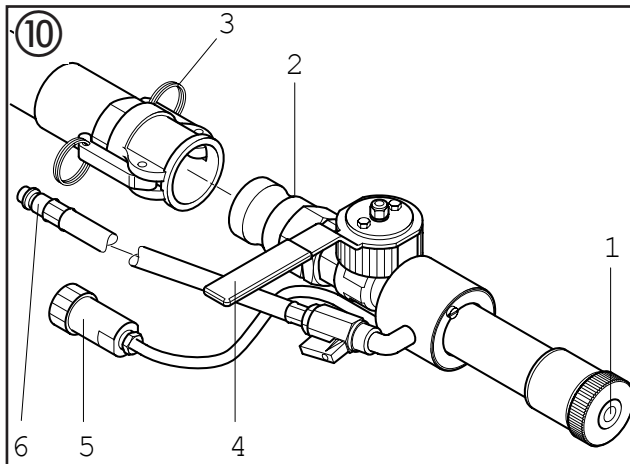

**6.6 REMOTE CONTROL (ACCESSORY/ NOT INCLUDED IN THE SCOPE OF DELIVERY)**

The remote control can be used to set the operating mode (Fig. 13, 1) and delivery volume (Fig. 13, 2) without the operator having to physically go to the machine. The remote control can be secured to the spray lance with a cable tie.

**6.6.1 REMOTE CONTROL ASSEMBLY**

- Ensure that the selector switch (Fig. 6, 4) is in the "A" position and that the mains plug is disconnected.
- Connect connection cable (Fig. 14, 1) to top connection (Fig. 14,2).
- Connect mains plug to mains power supply.
- Set the switch (Fig. 14, 3) to "II", to activate the remote control.

<b>i</b>	If the connection cable is disconnected from the pump, the pump automatically switches off.
----------	---

**PNEUMATIC SPRAY LANCE**

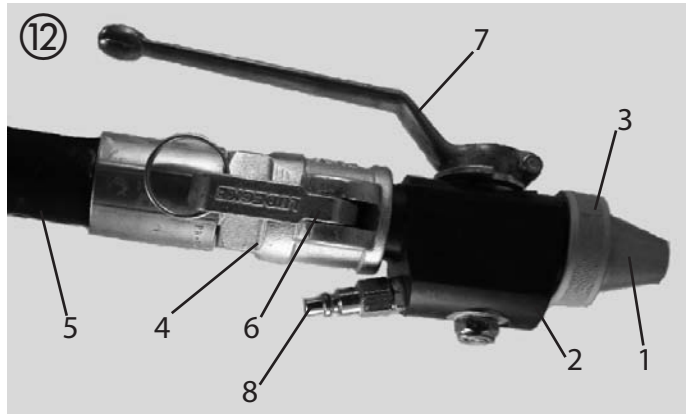

**6.6 REMOTE CONTROL (ACCESSORY/ NOT INCLUDED IN THE SCOPE OF DELIVERY)**

The remote control can be used to set the operating mode (Fig. 13, 1) and delivery volume (Fig. 13, 2) without the operator having to physically go to the machine. The remote control can be secured to the spray lance with a cable tie.

**6.6.1 REMOTE CONTROL ASSEMBLY**

- Ensure that the selector switch (Fig. 6, 4) is in the "A" position and that the mains plug is disconnected.
- Connect connection cable (Fig. 14, 1) to top connection (Fig. 14,2).
- Connect mains plug to mains power supply.
- Set the switch (Fig. 14, 3) to "II", to activate the remote control.

<b>i</b>	If the connection cable is disconnected from the pump, the pump automatically switches off.
----------	---

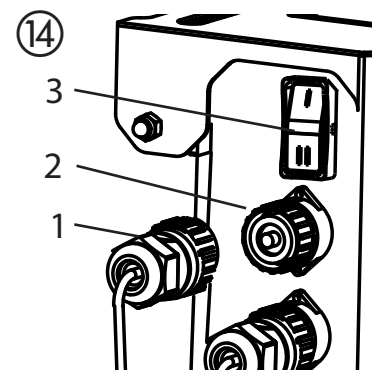
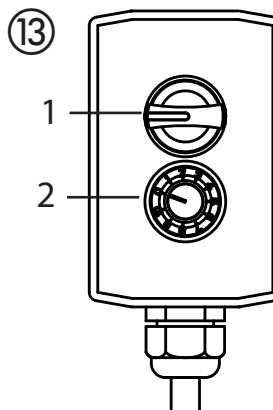

## AUTOMATIC SPRAY LANCE

### 6.7 PREPARING THE MORTAR SPRAYING MACHINE (FIG. 15)

#### Recommended sliding means for the mortar hose

	Water is not sufficient as a sliding means. Danger of clogging! Use cellulose paste (e.g. Metylan wallpaper paste, art no. 2312136)
--	---

- Fill 2–3 l cellulose paste into a suitable container.
- Connect the mortar spraying machine to the mains supply. The operation light (1) shows operational readiness.
- Place container under mortar spraying machine.
- Pull safety pin (2) to the rear and press down mortar spraying machine frame (3) until machine engages in the bottom position.

	<b>Risk of injury from escaping material.</b> <b>Before switching on, always check that the material tap on the spray lance is closed.</b> <b>Close material tap whenever stopping work.</b>
--	--

- Set selector switch (4) to "A".
- Set delivery volume controller (5) to „3“.

	<b>Do not bend the mortar hose!</b> <b>Protect it against damage, for example against being driven over as well as against sharp objects and edges.</b>
--	--

- Hold the spray lance over the container.
- Open material tap (3, Fig. 16) on spray lance (material tap facing to the rear), the mortar spraying machine is switched on.
- If cellulose paste is pumped into the mortar hose, close material tap (3, Fig. 16). (Material tap at 90° to spray lance)
- Replace container and lubricant with container and coating material.
- Hold spray lance above container with cellulose paste.
- Open material tap (3, Fig. 16) on spray lance.
- As soon as coating material exits from spray lance, close material tap (3, Fig. 16).  
The mortar spraying machine is now full and ready.

## PNEUMATIC SPRAY LANCE

### 6.7 PREPARING THE MORTAR SPRAYING MACHINE (FIG. 15)

#### Recommended sliding means for the mortar hose

	Water is not sufficient as a sliding means. Danger of clogging! Use cellulose paste (e.g. Metylan wallpaper paste, art no. 2312136)
--	---

- Fill 2–3 l cellulose paste into a suitable container.
- Connect the mortar spraying machine to the mains supply. The operation light (1) shows operational readiness.
- Place container under mortar spraying machine.
- Pull safety pin (2) to the rear and press down mortar spraying machine frame (3) until machine engages in the bottom position.

	<b>Risk of injury from escaping material.</b> <b>Before switching on, always check that the material tap on the spray lance is closed.</b> <b>Close material tap whenever stopping work.</b>
--	--

- Set selector switch (4) to "A".
- Set delivery volume controller (5) to „3“.
- Switch off compressor.

	<b>Do not bend the mortar hose!</b> <b>Protect it against damage, for example against being driven over as well as against sharp objects and edges.</b>
--	--

- Hold the spray lance over the container.
- Set selector switch to "F".
- Open material tap (1, Fig. 17) on spray lance. (Material tap at 90° to spray lance)
- If cellulose paste is pumped into the mortar hose, close material tap (material tap facing to the rear).
- Set selector switch to "A".
- Replace container and lubricant with container and coating material.
- Hold spray lance above container with cellulose paste.
- Set selector switch to "F".
- Open material tap (1, Fig. 17) on spray lance.
- As soon as coating material exits from spray lance, close material tap (1, Fig. 17).
- Set selector switch to "A".
- Switch on compressor.  
The mortar spraying machine is now full and ready.

**AUTOMATIC SPRAY LANCE**

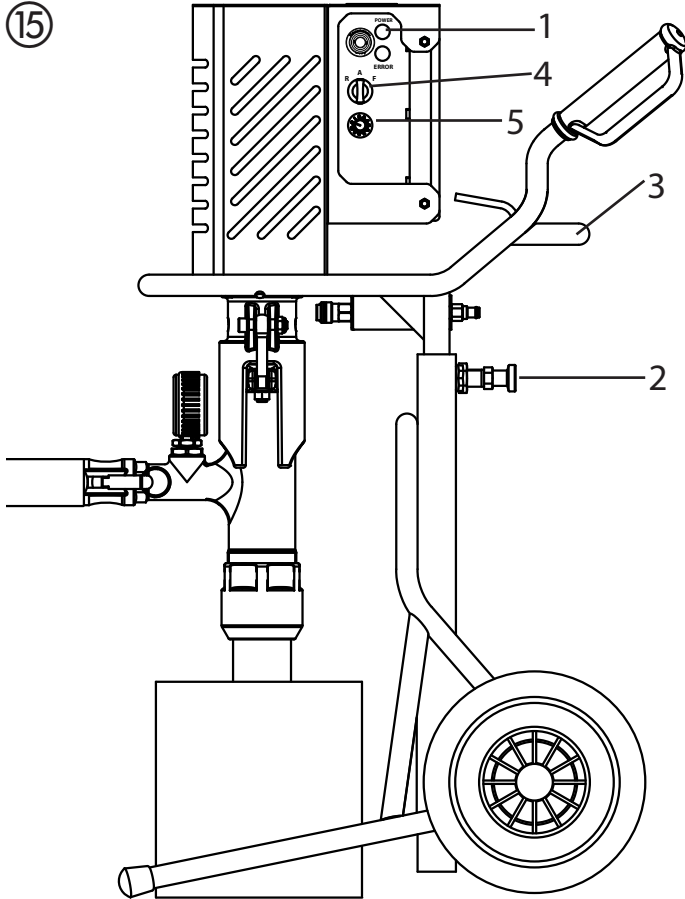

**6.8 BEGINNING OF THE SPRAYING PROCESS**

- Open the air tap (Fig. 16, 2) and material tap (Fig. 16, 1) at the spray lance.
- Set the amount of material using the volume regulator and the amount of air by setting the air tap (Fig. 16, 2) in order to achieve the corresponding spray pattern.

	<b>Increased material tap wear. Do not use the material tap to set the material volume. The delivery volume controller should be used for this purpose.</b>
--	---

**6.9 END OF THE SPRAYING PROCESS**

- Close the material tap (Fig. 16, 3).
- Close the air tap (Fig. 16, 2).

	<b>Always close material tap at end of the spray process.</b>
--	---

**PNEUMATIC SPRAY LANCE**

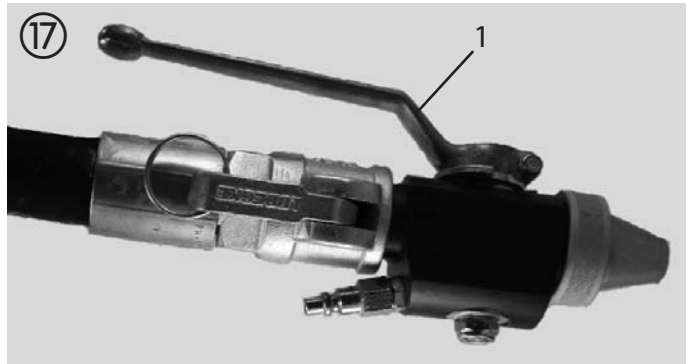
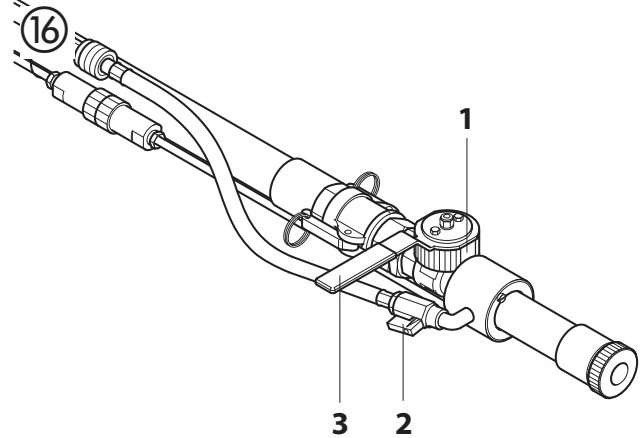

**6.8 BEGINNING OF THE SPRAYING PROCESS**

- Open material tap (1, Fig. 17) on spray lance.
- Set the amount of material using the volume regulator (fig. 15, 5) in order to achieve the corresponding spray pattern.

	<b>Increased material tap wear. Do not use the material tap to set the material volume. The delivery volume controller should be used for this purpose.</b>
--	---

**6.9 END OF THE SPRAYING PROCESS**

- Close material tap (1, Fig. 17) on spray lance.

	<b>Always close material tap at end of the spray process.</b>
--	---



## 7 GENERAL INFORMATION ABOUT THE APPLICATION TECHNIQUE

### 7.1 SPRAYING TECHNIQUE

While spraying hold the spray lance at a uniform distance of 30 – 60 cm from the object. Otherwise the spray pattern will be uneven.

The spray pattern depends on the coating material, viscosity, tip size, convey capacity and amount of atomizing air.

**Examples:**

**Fine texture** → large amount of atomizing air

**Rough texture** → small amount of atomizing air

**Higher convey capacity** → larger amount of atomizing air

Test the desired texture on a test surface.

The lateral limit of the spray jet should not be too sharp. The distance between the spray lance and the object should therefore be selected correspondingly.

The spray edge should be gradual in order to facilitate overlapping of the next coat.

If the spray lance is moved parallel and at an angle of 90° to the surface to be coated, the paint mist is minimized.

**Note:**

Grains and pigments with a sharp edge result in a high rate of wear of the pump, mortar hose, material tap and tip.

## 8 SHUTTING DOWN AND CLEANING

	<b>Do not clean the motor and control unit of the mortar spraying machine moistly. And certainly do not spray down the unit with high-pressure cleaners or high-pressure steam cleaners. Danger of short-circuits caused by water ingressing.</b>
--	---

### 8.1 CLEANING THE MORTAR HOSE

- Pump the paint bucket empty or replace it by an empty vessel/bucket.

**Important: Do not let the mortar spraying machine run dry.**

- Switch off mortar spraying machine and compressor.
- Close material tap on spray lance.

- Remove the texture tip from the spray lance and clean it.
- Submerge suction tube in a bucket full of water and hold spray lance above material container.
- Set delivery volume controller to „5“.
- If using automatic lance, open material tap on spray lance; if using pneumatic lance, set selector switch to “F”.
- Pump material out of hose into container until the material exiting the hose is just a thin liquid.
- If using automatic lance, close material tap on spray lance; if using pneumatic lance, set selector switch to “A”.

	<b>The mortar hose must be pressureless. If necessary, set the selector switch briefly to “R” (reverse). Watch the manometer → 0 bar. Wear safety goggles.</b>
--	--

- Decouple mortar hose from pump unit.
- Decouple spray lance from mortar hose.
- Insert cleaning ball into mortar hose and reconnect mortar hose
- Set selector switch to “F”.
- After a few seconds the cleaning ball is emitted from the spray lance.
- Depending on the processed coating material, repeat the cleaning process 3 – 4 times.

	<b>The mortar hose must be pressureless. If necessary, set the selector switch briefly to “R” (reverse). Watch the manometer → 0 bar. Wear safety goggles.</b>
--	--

- Set selector switch to “A”.
- Decouple mortar hose from pump unit.

	A further cleaning option is to use the cleaning adapter (accessory). This cleaning adapter can be connected to a water hose or a tap by means of the claw coupling. Insert cleaning ball into the mortar hose. Couple the mortar hose to the cleaning adapter and rinse through with water.
--	--

### 8.2 CLEANING THE DEVICE AND REPLACING THE STATOR

- Clean mortar spraying machine. To do so, pump graphite pump sliding means or water mixed with dishwashing liquid through the pump.

## SHUTTING DOWN AND CLEANING

**Dismantling**

**Mortar spraying machine must be depressurised.**  
**If necessary, set the selector switch briefly to "R" (reverse).**  
**Watch the manometer --> 0 bar.**  
**Wear safety goggles.**



Only the person operating the machine may remove the pump unit.

- Move selector switch (1) to "A" and set delivery volume controller (2) to „0“.
- Pull safety pin (3) to rear to release lock. Pull PC430 up by its frame (4) until the machine engages in the top position.
- Loosen the union nut on the pump tube using the special key (approx. a one-quarter turn)
- Remove nuts from locking pins (5). Fold up locking pins so that they remain in contact with magnets in handle.
- Set delivery volume controller (2) to 1 or 2.
- Firmly hold pump unit (6) with one hand. Move selector switch (1) to "R" position (reverse gear) and hold there. As soon as the pump unit (6) has released, move selector switch to "A" and remove pump unit.
- Disconnect mains plug.
- Loosen/unscrew pump pipe (8) from pump unit (6) using the special key provided.
- Remove stator (9) from pump pipe.

**Cleaning the pump unit**

Once the pump pipe has been removed from the pump unit, the pump housing (10) up to the seals can be cleaned with a jet of water and suitable bottle brush.

Thoroughly clean rotor (11), stator (9) and pump pipe (8) with water and a brush too if necessary.

Then spray rotor (11) and stator (9) with a suitable pump lubricant.

Keep the thread of the pump housing and the pump tube clean so that leaking after the assembly is avoided.

**Mounting**

Insert stator (9) in pump pipe (8) such that the journal sits in the largest recess.

Use special key to screw pump pipe back onto pump unit (6).

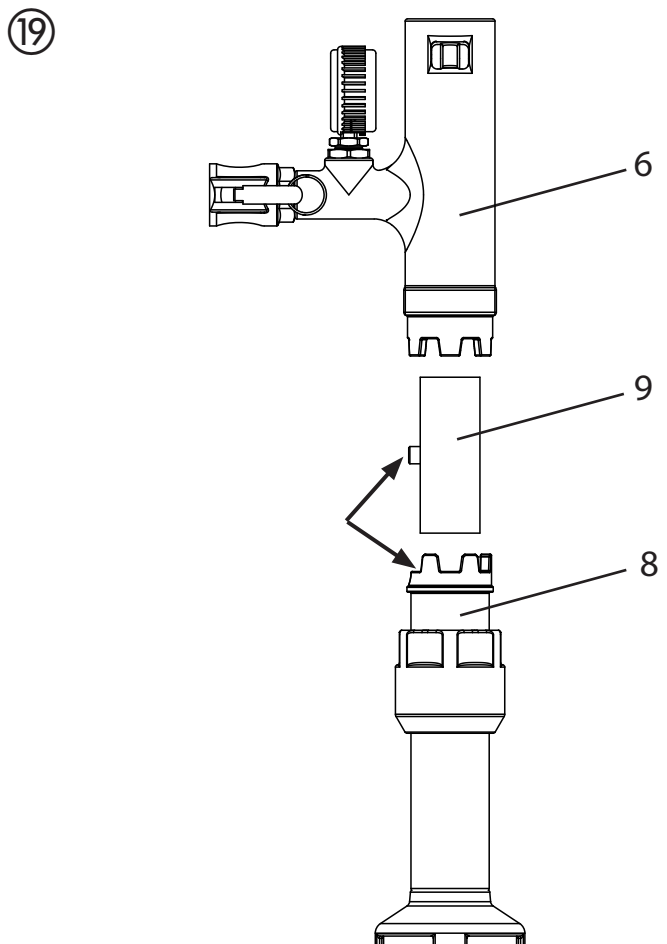
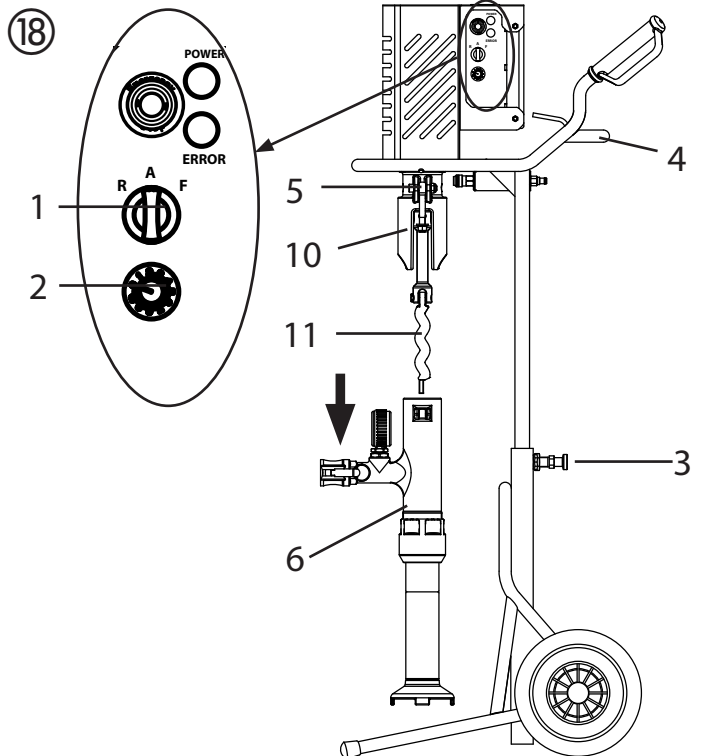

### 8.3 CLEANING THE SPRAY LANCE

- Clean the texture tip.
- Use cleaning needles to clean the air holes in the texture tip.
- Use a bottle brush to clean the inside of the spray lance.

## 9 MAINTENANCE



**ATTENTION!** It is imperative that the machine be deenergized by unplugging the plug before all work and maintenance work. Otherwise there is a danger of short-circuiting! Repairs may only be carried out by qualified personnel who dispose the corresponding training and experience. The device must be tested by a skilled electrician after every repair.

The mortar spraying machine is designed so that a minimum of care and maintenance is required. However, the following work has to be carried out and components checked regularly:

### 9.1 MECHANICAL MAINTENANCE

- Keep the thread at the pump tube and pump housing clean and, if appropriate, seal.
- Check the seals at all the couplings and connecting pieces for leaks. If appropriate, replace worn seals.
- Check the following for damage before every usage:
  - Mortar hose
  - Power cable
  - Control unit
  - Remote control connection cable (if present)
- Check the suction system for leaks during every usage.

### 9.2 ELECTRICAL MAINTENANCE

- The electrical drive and its ventilation slots must always be kept clean and may not be cleaned with water. **Danger of short-circuits.**

### 9.3 LONG PERIODS OF NON-USAGE

If the mortar spraying machine is not used for a longer period, it has to be cleaned thoroughly and protected against corrosion.



Remove pump unit so that rotor cannot seize on stator.

### 9.4 ROTOR REPLACEMENT (FIG. 20)

- Loosen fixing screw (1) and remove old rotor (2).
- Fit new rotor with new fixing screw.
- Glue fixing screw with Loctite 243.



Note: use Loctite 243 only.

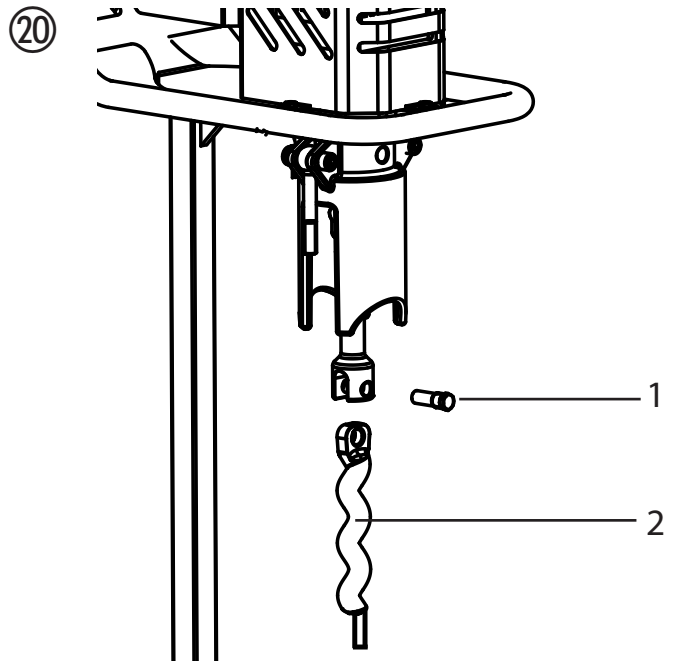

## 10 ELIMINATING FAULTS

MALFUNCTION	POSSIBLE CAUSE	ELIMINATION
Mortar spraying machine not running. Green operating light lights up	Delivery volume controller is set to „0“  Lance control cable not connected or damaged  Switched to remote control operation (Switch 6 Fig. 3 in Position "II") but remote control not connected	Increase delivery volume  Check control cable  Connect a remote control or set switch (6 Fig. 3) to Position "I", in order to switch off operation with remote control.
Mortar spraying machine not running. Green operating light not does not light up	Power supply missing.	<ul style="list-style-type: none"> <li>- Plug in the power plug.</li> <li>- Check the power cable for damage and replace, if necessary.</li> <li>- Check the power supply.</li> </ul>
Mortar spraying machine not running. Red indicator light lights up	Mortar spraying machine was over-loaded/overheated.	Close material tap and disconnect mains plug. Switch the mortar spraying machine on again after about 5 minutes.
Mortar spraying machine cannot be switched on/off by means of the remote control.	Remote control not on.  Remote control line not connected or defect.	Set selector switch to "A" and set switch (Fig. 3, 6) to position "II", in order to activate remote control.  Connect remote control, check connections, check remote control line for damage.
Mortar spraying machine cannot rotate the rotor	Rotor stuck in stator. Pump was not lubricated with pump sliding means.	Set the selector switch alternatively briefly to "F" (forwards) – "R" (reverse). Contact Wagner customer service if the problem cannot be resolved.
Mortar spraying machine builds up pressure in the mortar hose. However, coating material does not arrive at the spray lance.	Coating material "plug" in the mortar hose. Mortar hose not prerinsed with cellulose paste.	<p>Depressurize the mortar hose – set the selector switch to "R" (reverse). Pump the coating material back into the container.</p> <div style="border: 1px solid black; padding: 5px; display: flex; align-items: center;"> <p><b>The mortar hose must be pressureless. Watch the manometer --&gt; 0 bar. Wear safety goggles.</b></p> </div> <p>Decouple mortar hose and rinse with water hose. When the plug has been removed, fill cellulose paste in the mortar hose. Couple the mortar hose back on.</p>

MALFUNCTION	POSSIBLE CAUSE	ELIMINATION
Coating material is suddenly not emitted during spraying.	<p>Texture tip is clogged because of impurity in the coating material or because the granular size is too large.</p> <p>Texture tip too small.</p> <p>Coating material "plug" in the mortar hose. Mortar hose not prerinsed with cellulose paste.</p> <p>No coating material in the container. Pump has sucked in air.</p>	<p>Switch the mortar spraying machine off. Close the material cock at the spray lance. Remove the texture tip and clean it.</p> <p>Select a larger texture tip. Rule of thumb: Granular size x 3 → Tip size</p> <p>Depressurize the mortar hose – set the selector switch to "R" (reverse). Pump the coating material back into the container.</p> <div style="border: 1px solid black; padding: 5px; display: flex; align-items: center;"> <p><b>The mortar hose must be pressureless. Watch the manometer → 0 bar. Wear safety goggles.</b></p> </div> <p>Decouple mortar hose and rinse with water hose. When the plug has been removed, fill cellulose paste in the mortar hose. Couple the mortar hose back on.</p> <p>Top up coating material in container and pump round until coating material exits without bubbles. <b>Attention: Always top up with sufficient coating material. Do not let the pump run dry. Pump overheats, resulting in a danger of „plugs“.</b></p>
Spray pattern is not clean and even.	<p>Air ducts in the texture tip are partially closed with coating material.</p> <p>Air volume incorrectly set.</p> <p>Poor mortar spraying machine cleaning</p> <p>No coating material in the container. Pump has sucked in air.</p>	<p>Switch the mortar spraying machine off. Close the material tap at the spray lance. Remove the texture tip. Clean the air ducts of the texture tip.</p> <p>Change air volume setting.</p> <p>Thoroughly clean mortar spraying machine</p> <p>Top up coating material in container and pump round until coating material exits without bubbles. <b>Attention: Always top up with sufficient coating material. Do not let the pump run dry. Pump overheats, resulting in a danger of „plugs“.</b></p>

ELIMINATING FAULTS

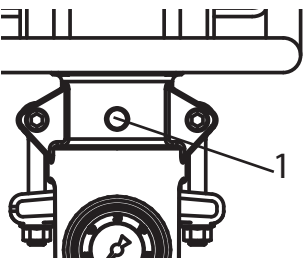
MALFUNCTION	POSSIBLE CAUSE	ELIMINATION
<p>Pressure at the manometer rises to more than 40 bars.</p>	<p>Viscosity of the coating material too high. Mortar hose diameter too small.</p> <p>Mortar hose is too long.</p> <p>Coating material "plug" in the mortar hose. Mortar hose not prerinsed with cellulose paste.</p>	<p>Dilute the coating material.</p> <p>Use a mortar hose with a larger diameter.</p> <p>Use a shorter mortar hose.</p> <p>Depressurize the mortar hose – set the selector switch to "R" (reverse). Pump the coating material back into the container.</p> <div style="border: 1px solid black; padding: 5px; display: flex; align-items: center;"> <p><b>The mortar hose must be pressureless. Watch the manometer --&gt; 0 bar. Wear safety goggles.</b></p> </div> <p>Decouple mortar hose and rinse with water hose. When the plug has been removed, fill cellulose paste in the mortar hose. Couple the mortar hose back on.</p>
<p>Mortar spraying machine does not pump enough coating material.</p>	<p>Convey capacity selected too low.</p> <p>Mortar hose diameter too small.</p> <p>Stator worn.</p> <p>Texture tip too small.</p>	<p>Set the volume regulator higher.</p> <p>Use a mortar hose with a larger diameter.</p> <p>Mount a new stator, if necessary, also a new rotor. <b>Attention:</b> Spray on pump sliding means.</p> <p>Select a larger texture tip. Rule of thumb: Granular size x 3 --&gt; Tip size</p>
<p>Coating material is emitted at the inspection hole (1).</p> 	<p>The shaft seal that seals between the pump unit and the drive unit is worn.</p>	<p>Stop work immediately because otherwise coating material may enter the drive and result in a defect. Clean machine and contact Wagner customer service.</p>

If the defect is not caused by one of the above-mentioned faults, have the defect eliminated by the WAGNER customer service.

## 11 SPARE PARTS LIST FOR PLASTCOAT 430

ITEM	ORDER NO.	DESIGNATION	ITEM	ORDER NO.	DESIGNATION
1	2311 768	Grab handle (1)	5	2312 304	Pipe bend, complete
2	2309 572	Flow switch, complete (pneumatic version only)	6	0342 314	Fix coupling seal M 27
3	2312 306	Rotor and fixing screw	7	2304 954	Stator
4	2304 989	Rubber seal	8	2312 305	Suction tube, complete
			9	2308 535	Special key

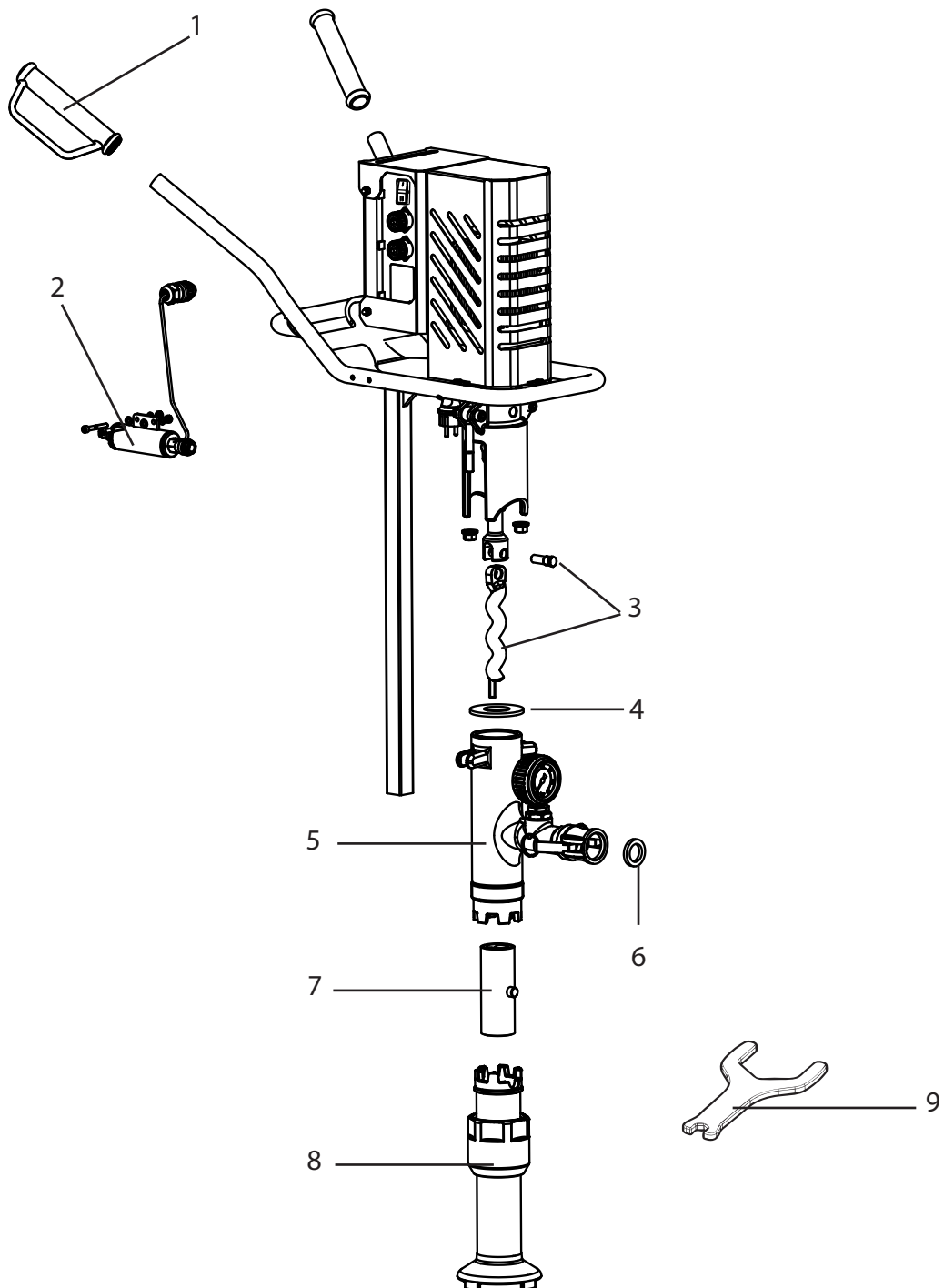

## 12 SPARE PARTS LIST OF CARRIAGE

ITEM	ORDER NO.	DESIGNATION
1	2304 966	Locking pin
2	2312 303	Wheel and wheel cap (1)
3	9990 866	Rubber cover (1)
4	2309 787	Protective cap (1)

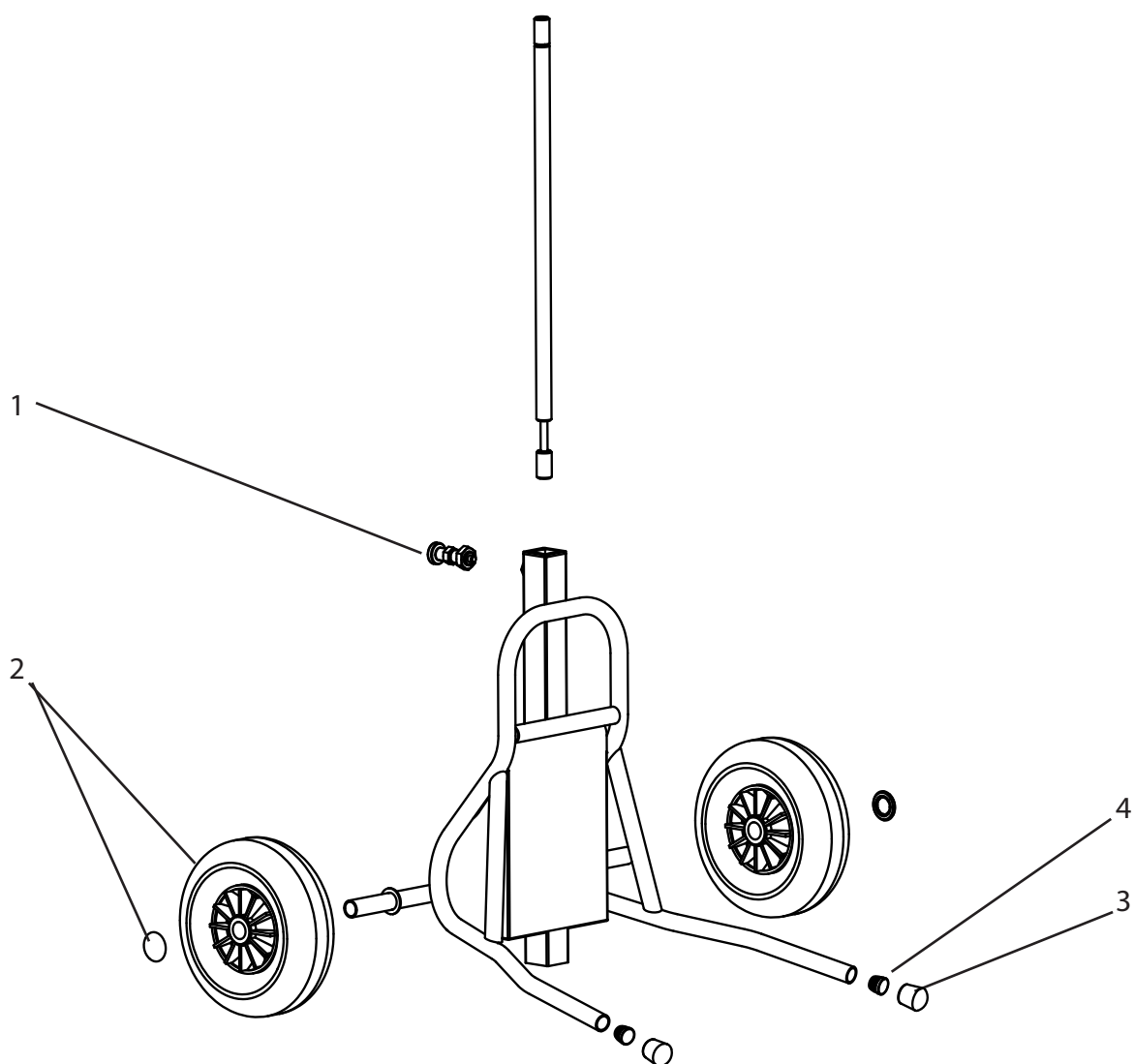



## 13 SPARE PARTS LIST – SPRAY LANCE WITH AUTOMATIC CONTROL

ITEM	PART NO.	DESIGNATION	ITEM	PART NO.	DESIGNATION
	0348 241	Spray lance with automatic control	8	0342 350	Sealing washer
	0348 904	Extension kit 500 mm long (material pipe and air pipe)	9	0342 351	Union nut
	0348 923	Extension kit 800 mm long (material pipe and air pipe)	10	0348 346	Material pipe 100 mm long
				0348 922	Material pipe 800 mm long
1	9910 208	Hexagon nut M8 DIN 985		0348 943	Material pipe 500 mm long
2	9920 102	Washer 8.4 DIN 433	11	9902 309	Pan head tapping screw 4.2 x 16
3	0348 243	Lever	12	0348 460	Cover
4	3051 679	O-ring 35 x 2	13	0348 216	Cable
5	0348 354	Air pipe 100 mm long	14	0348 244	Connection sleeve
	0348 921	Air pipe 800 mm long	15	3105 540	O-ring 26 x 2
	0348 942	Air pipe 500 mm long	16	0348 461	Stop
6	0348 355	Nozzle head	17	9920 104	Washer 4.3
7	0268 779	Texture tip 4	18	0268 338	Ball tap
	0348 915	Texture tip 5	19	9983 237	Double nipple 3/4 in – 1 in
	0268 780	Texture tip 6		9983 238	Double nipple 3/4 in – round thread 32 x 1/8 in
	0348 916	Texture tip 7	20	0342 313	Fix nipple connection V 27*
	0268 781	Texture tip 8 (standard)	21	9991 112	Ball tap*
	0348 917	Texture tip 9	22	0268 604	Air hose*
	0268 782	Texture tip 10			
	0342 327	Texture tip 12			

\* Loctite 222

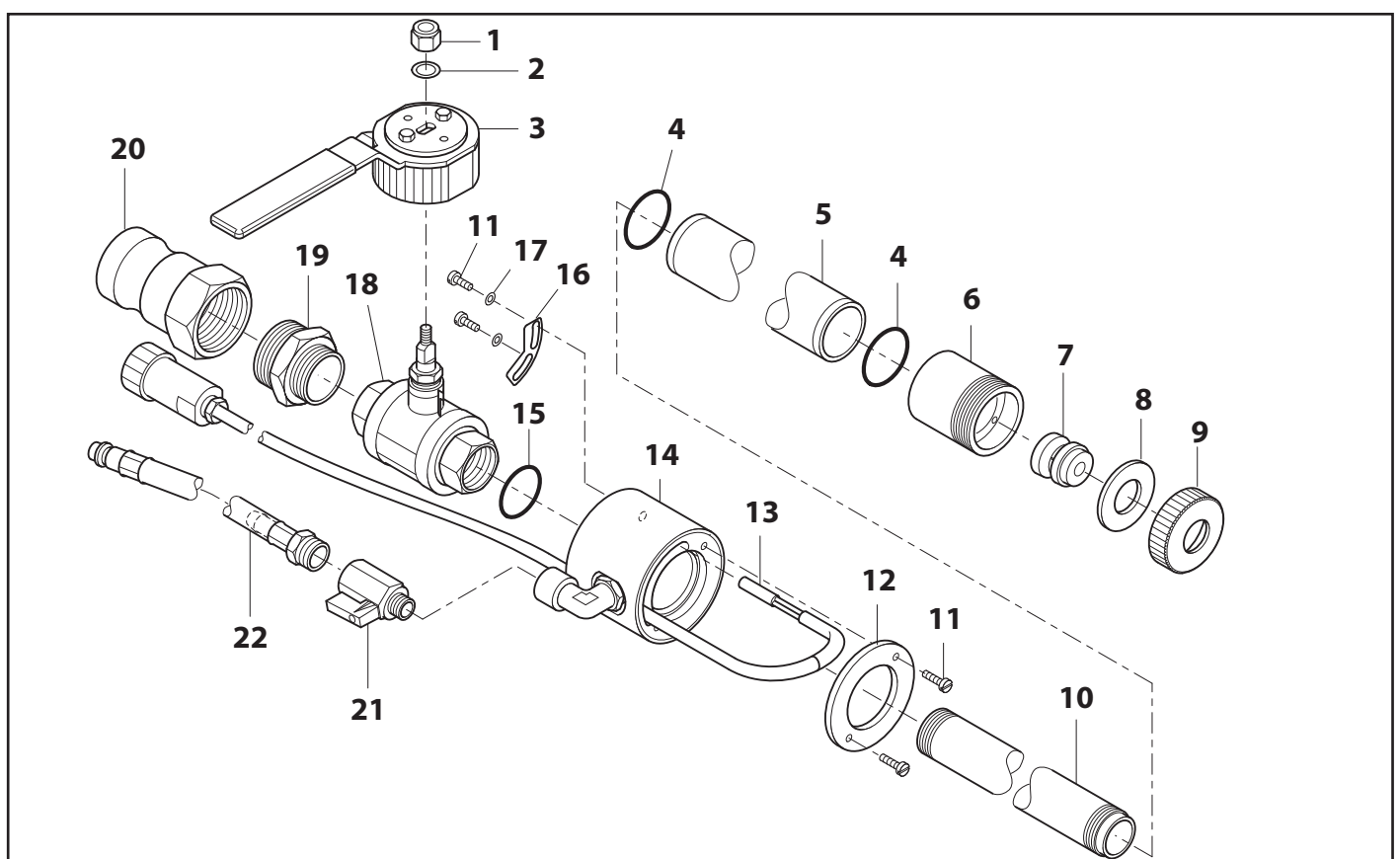

**14 SPARE PARTS LIST – PNEUMATIC SPRAY LANCE**

ITEM	PART NO.	DESIGNATION	ITEM	PART NO.	DESIGNATION
	2310 475	Spray lance complete (pos. 1-8,10-12)	13	2314 215	Texture tip blue (3mm)
9	2312 568	Air hose *		2314 216	Texture tip red (4mm)
12	2312 570	Union nut		2314 217	Texture tip yellow (5mm)
				2314 218	Texture tip black (6mm)
				2314 219	Texture tip green (7mm)
				2315 346	Texture tip (8mm)
				2315 347	Texture tip (10mm)
				2315 348	Texture tip (12mm)

\* Glue with Loctite 243

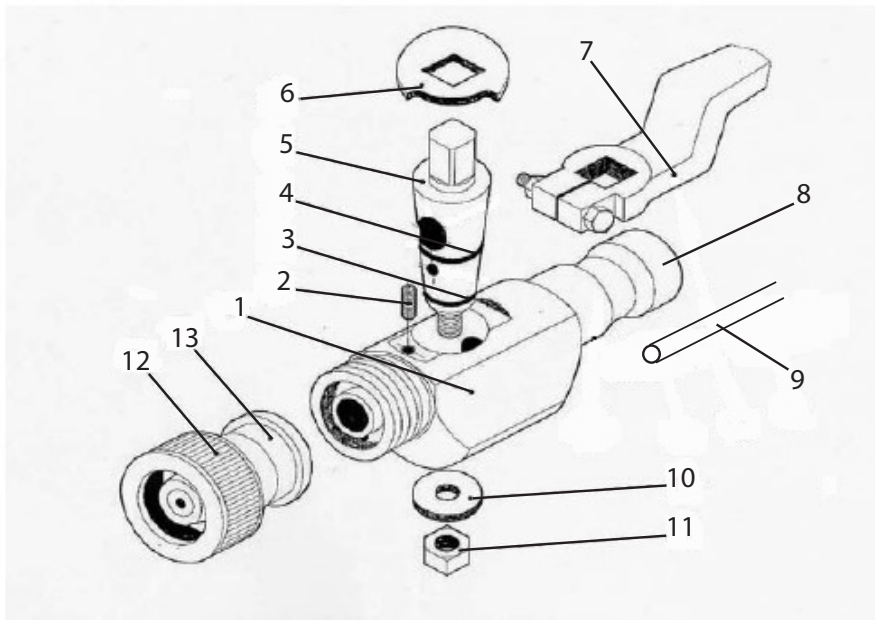

## 15 PLASTCOAT 430 ACCESSORIES

ITEM	ORDER NO.	DESIGNATION	ITEM	ORDER NO.	DESIGNATION
1	0348 241	Automatic spray lance		0348 946	Mortar hose DN 35 – 13,3 m, Connection V 27
2	Texture tips for automatic spray lance 0348241:		12	0342 314	Fix coupling seal M 27
	0268 779	Texture tip 4	13	Mortar hose (including air hose) for pneumatic spray lance 2310475	
	0348 915	Texture tip 5		0342 736	Mortar hose DN 19 – 10 m, Connection V 27 – M 27
	0268 780	Texture tip 6		0342 737	Mortar hose DN 27– 10 m, Connection V 27 – M 27
	0348 916	Texture tip 7		2316 304	Mortar hose DN 19 – 2 m, Connection V 27 – round thread 32 x 1/8
	0268 781	Texture tip 8 (standard)		2311 632	Mortar hose DN 25 – 10 m, Connection V 27 – M 27
	0348 917	Texture tip 9	14	0342 912	Rendering lance 200 U
	0268 782	Texture tip 10	15	0268 726	Rendering tip set 14, 16, 18
	0342 327	Texture tip 12	16	2311 921	Compressor VKM 592, 230 V~, 50 Hz, suction volume 590 l/min
	0268 905	Texture tip set 4, 6, 8, 10	17	2309 956	Large volume container 100 litres incl. lid
3	2310 475	Pneumatic spray lance		2309 960	Large volume container 100 litres incl. lid and bag support with pressing roller
4	Texture tips for pneumatic spray lance 2310475		18	2312 159	Connection kit for large volume container
	2314 215	Texture tip blue (3mm)	19	2308 417	Remote control
	2314 216	Texture tip red (4mm)	20	2309 961	Remote control extension cable 15m (no picture)
	2314 217	Texture tip yellow (5mm)	21	2311 692	Control cable for automatic spray lance 14 m (no picture)
	2314 218	Texture tip black (6mm)	22	2312 136	Lubricant for mortar hose (Metylan wallpaper paste) 125g (no picture)
	2314 219	Texture tip green (7mm)	23	0348 960	Ceiling spray lance
	2315 346	Texture tip (8mm)			
	2315 347	Texture tip (10mm)			
	2315 348	Texture tip (12mm)			
5	0342 916	Cleaning needle			
6	0342 330	Cleaning ball for DN 19 mm			
	0342 331	Cleaning ball for DN 25/27 mm			
7	0342 329	Bottle brush for cleaning the inside of the outlet unit and spray lance			
8	9992 824	Pump sliding means 500 ml			
9	0342 215	Hose holder			
10	0342 241	Cleaning adapter M 27 – GK			
	0348 948	Cleaning adapter M 35 – GK			
11	Mortar hose (including air hose and control cable) for automatic spray lance 0348241				
	2317 758	Mortar hose DN 19 – 2 m, Connection V 27 – round thread 32 x 1/8			
	0342 706	Mortar hose DN 19 – 10 m, Connection V 27			
	0348 930	Mortar hose DN 19 – 20 m, Connection V 27			
	0348 912	Mortar hose DN 27 – 10 m, Connection V 27			

PlastCoat 430 Accessories illustration

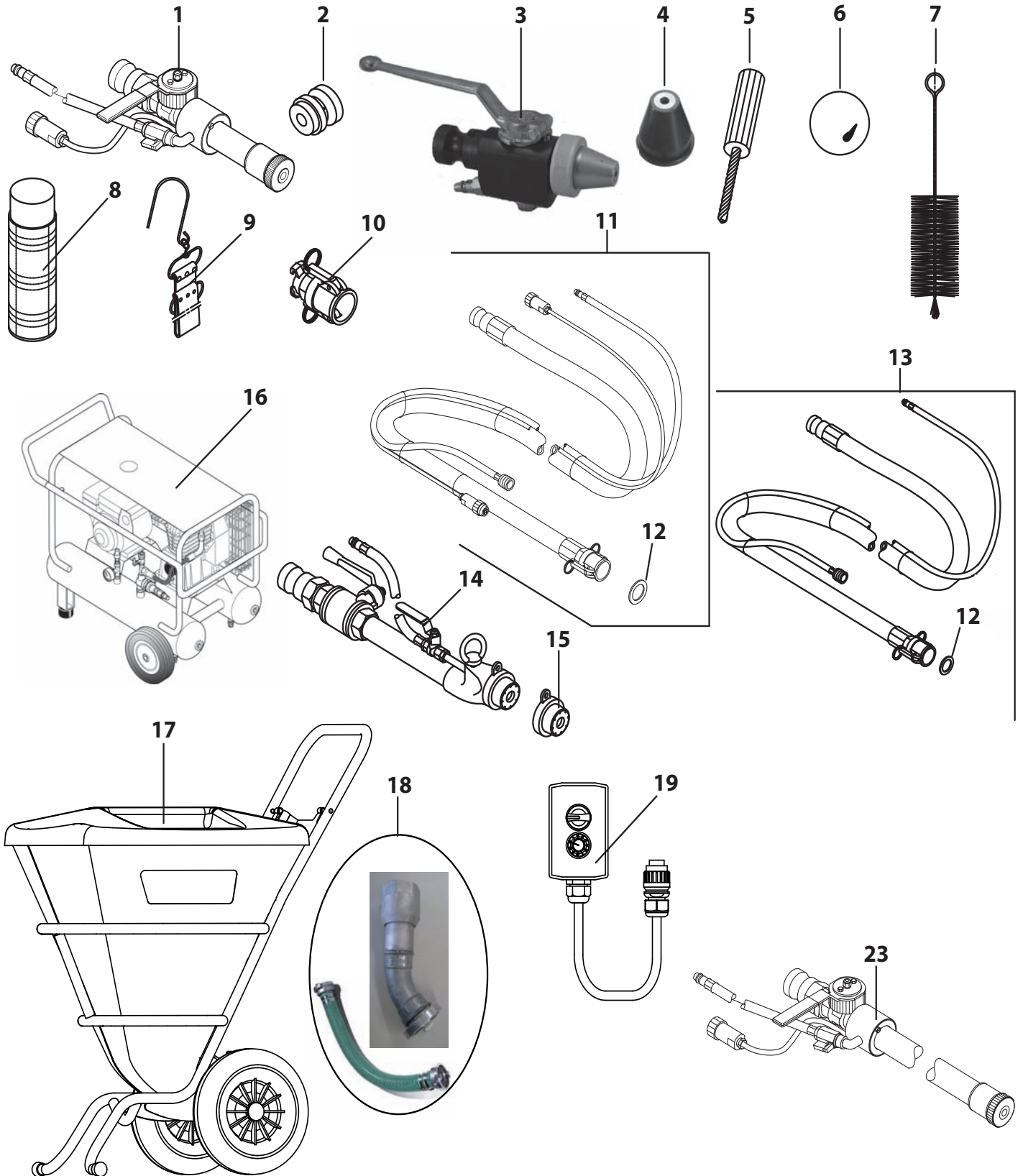

## TESTING OF THE MORTAR SPRAYING MACHINE

For safety reasons, we would recommend having the device checked by an expert as required but at least every 12 months to ensure that it can continue to operate safely.

In the case of unused devices, the check can be postponed until they are next started up.

All (potentially deviating) national inspection and maintenance regulations must also be observed.

If you have any questions, please contact the customer service team at Wagner.

## NOTE ON DISPOSAL

In accordance with European Directive 2002/96/EC on the disposal of waste electrical equipment and its implementation in national law, this product may not be disposed of with the household refuse, but must rather be recycled in an environmentally correct manner.



Your waste WAGNER device will be taken back by us or our representatives and disposed of environmentally correctly. Please contact one of our service points or one of our representatives or us directly to this purpose.

## IMPORTANT INFORMATION ON PRODUCT LIABILITY

An EU directive valid since 01.01.1990 specifies that the manufacturer is only liable for his products if all the parts originate from the manufacturer or are approved by him, and if the units are mounted and operated properly. If accessories or spare parts from third parties are used, liability can be partially or completely inapplicable. In extreme cases the responsible authorities can prohibit the use of the entire unit (German industrial employer's liability insurance association and factory inspectorate).

With original WAGNER accessories and spare parts, compliance with all safety regulations is guaranteed.

## GUARANTEE DECLARATION

(Status 01.02.2009)

### 1. Scope of guarantee

All Wagner professional colour application devices (hereafter referred to as products) are carefully inspected, tested and are subject to strict checks under Wagner quality assurance. Wagner exclusively issues extended guarantees to commercial or professional users (hereafter referred to as "customer") who have purchased the product in an authorised specialist shop, and which relate to the products listed for that customer on the Internet under [www.wagner-group.com/profi-guarantee](http://www.wagner-group.com/profi-guarantee).

The buyer's claim for liability for defects from the purchase agreement with the seller as well as statutory rights are not impaired by this guarantee.

We provide a guarantee in that we decide whether to replace or repair the product or individual parts, or take the device back and reimburse the purchase price. The costs for materials and working hours are our responsibility. Replaced products or parts become our property.

### 2. Guarantee period and registration

The guarantee period amounts to 36 months. For industrial use or equal wear, such as shift operations in particular, or in the event of rentals it amounts to 12 months.

Systems driven by petrol or air are also guaranteed for a 12 month period.

The guarantee period begins with the day of delivery by the authorised specialist shop. The date on the original purchase document is authoritative.

For all products bought in authorised specialist shops from 01.02.2009 the guarantee period is extended to 24 months providing the buyer of these devices registers in accordance with the following conditions within 4 weeks of the day of delivery by the authorised specialist shop.

Registration can be completed on the Internet under [www.wagner-group.com/profi-guarantee](http://www.wagner-group.com/profi-guarantee).

The guarantee certificate is valid as confirmation, as is the original purchase document that carries the date of the purchase. Registration is only possible if the buyer is in agreement with having the data being stored that is entered during registration.

When services are carried out under guarantee the guarantee period for the product is neither extended nor renewed.

Once the guarantee period has expired, claims made against the guarantee or from the guarantee can no longer be enforced.

### 3. Handling

If defects can be seen in the materials, processing or performance of the device during the guarantee period, guarantee claims must be made immediately, or at the latest within a period of 2 weeks.

The authorised specialist shop that delivered the device is entitled to accept guarantee claims. Guarantee claims may also be made to the service centres named in our operating instructions. The product has to be sent without charge or presented together with the original purchase document that includes details of the purchase date and the name of the product. In order to claim for an extension to the guarantee, the guarantee certificate must be included.

The costs as well as the risk of loss or damage to the product in transit or by the centre that accepts the guarantee claims or who delivers the repaired product, are the responsibility of the customer.

### 4. Exclusion of guarantee

Guarantee claims cannot be considered

- for parts that are subject to wear and tear due to use or other natural wear and tear, as well as defects in the product that are a result of natural wear and tear, or wear and tear due to use. This includes in particular cables, valves, packaging, jets, cylinders, pistons, means-carrying housing components, filters, pipes, seals, rotors, stators, etc. Damage due to wear and tear that is caused in particular by sanded coating materials, such as dispersions, plaster, putty, adhesives, glazes, quartz foundation.
- in the event of errors in devices that are due to non-compliance with the operating instructions, unsuitable or unprofessional use, incorrect assembly and/or commissioning by the buyer or by a third party, or utilisation other than is intended, abnormal ambient conditions, unsuitable coating materials, unsuitable operating conditions, operation with the incorrect mains voltage supply/frequency, over-operation or defective servicing or care and/or cleaning.
- for errors in the device that have been caused by using accessory parts, additional components or spare parts that are not original Wagner parts.
- for products to which modifications or additions have been carried out.
- for products where the serial number has been removed or is illegible
- for products to which attempts at repairs have been carried out by unauthorised persons.
- for products with slight deviations from the target properties, which are negligible with regard to the value and usability of the device.
- for products that have been partially or fully taken apart.

### 5. Additional regulations.

The above guarantees apply exclusively to products that have been bought by authorised specialist shops in the EU, CIS, Australia and are used within the reference country.

If the check shows that the case is not a guarantee case, repairs are carried out at the expense of the buyer.

The above regulations manage the legal relationship to us conclusively. Additional claims, in particular for damages and losses of any type, which occur as a result of the product or its use, are excluded from the product liability act except with regard to the area of application.

Claims for liability for defects to the specialist trader remain unaffected.

German law applies to this guarantee. The contractual language is German. In the event that the meaning of the German and a foreign text of this guarantee deviate from one another, the meaning of the German text has priority.

J. Wagner GmbH  
 Division Professional Finishing  
 Otto Lilienthal Strasse 18  
 88677 Markdorf  
 Federal Republic of Germany

J. WAGNER GmbH

Subject to modifications · Printed in Germany

J. Wagner GmbH Otto Lilienthal-Str.18 D-88677 Markdorf



**CE** Konformitätserklärung

Hiermit erklären wir, daß die Bauart von Mörtelspritzmaschine



**CE** Declaration of conformity

Herewith we declare that the supplied version of Mortar spraying machine



**CE** Déclaration de conformité

Par la présente, nous déclarons, que le type de Machine à projeter le mortier



**CE** Konformiteitsverklaring

hiermede verklaren wij, dat de in de handel gebrachte machine Mortelspuitmachine

**WAGNER PC-430, 230V, 50Hz**

folgenden einschlägigen Bestimmungen entspricht:

2006/42 EG, 2004/108 EG, 2006/95 EG

complies with the following provisions applying to it:

2006/42 EG, 2004/108 EG, 2006/95 EG

correspond aux dispositions pertinentes suivantes:

2006/42 EG, 2004/108 EG, 2006/95 EG

voldeet aan de eisen van de in het vervolg genoemde bepalingen:

2006/42 EG, 2004/108 EG, 2006/95 EG

Angewendete harmonisierte Normen, insbesondere:

EN ISO 12100-1/-2, EN 12001, EN 60204-1, EN 55014, EN 61000-3-2 :06, EN 61000-3-3 :08, EN 61000-6-1:07, EN 61000-6-3:07

Applied harmonized standards, in particular:  
Normes harmonisées utilisées, notamment:  
Gebruikte geharmoniseerde normen, in het bijzondere:

Angewendete nationale technische Spezifikationen, insbesondere:

Applied national technical standards and specifications, in particular:

Normes et specifications techniques nationales qui ont été utilisées, notamment:

Gebruikte nationale technische normen en specificaties, in het bijzondere:

**BGR 183**

Vice President Product Planning & Strategy  
Hr. T. Jeltsch (Mr.)

Signature

Head of Development

Hr. J. Ulbrich (Mr.)  
Dokumentationsverantwortlicher  
Responsible person for documents  
Responsable de la documentation  
Documentatieverantwoordelijke

## EUROPA-SERVICENETZ / EUROPEAN SERVICE NETWORK / RÉSEAU DE SERVICE APRÈS-VENTE EN EUROPE

### RETE DI ASSISTENZA EUROPEA / EUROPA – SERVICENETWERK

- |           |  |           |  |           |   |
|-----------|--|-----------|--|-----------|---|
| <b>A</b>  | J. Wagner Ges.m.b.H.<br>Ottogasse 2/20<br>2333 Leopoldsdorf<br>Österreich<br>Tel. +43/ 2235 / 44 158<br>Telefax +43/ 2235 / 44 163<br>office@wagner-group.at   | <b>DK</b> | Wagner Spraytech<br>Scandinavia A/S<br>Helgeshøj Allé 28<br>2630 Taastrup<br>Denmark<br>Tel. +45/43/ 27 18 18<br>Telefax +45/43/ 43 05 28<br>wagner@wagner-group.dk  | <b>GB</b> | Wagner Spraytech (UK) Limited<br>The Coach House<br>2 Main Road<br>Middleton Cheney OX17 2ND<br>Great Britain<br>UK-Helpline 0844 335 0517<br>5 p per minute (landline) |
| <b>B</b>  | Wagner Spraytech Benelux b.v.<br>Veilinglaan 56<br>1861 Meise-Wolvertem<br>Belgium<br>Tel. +32/2/269 46 75<br>Telefax +32/2/269 78 45<br>info@wagner-wsb.nl  | <b>E</b>  | Wagner Spraytech Iberica S.A.<br>P.O. Box 132, Crta. N-340<br>08750 Molins de Rey<br>Barcelona / Espania<br>Tel. +34/93/6800028<br>Telefax +34/93/66800555<br>info@wagnerspain.com                               | <b>I</b>  | Wagner Colora<br>Via Fermi, 3<br>20040 Burago di Molgora (MI)<br>Italia<br>Tel. +39/ 039 / 625 021<br>Telefax +39/ 039 / 685 18 00<br>info@wagnercolora.com             |
| <b>CH</b> | Wagner International AG<br>Industriestrasse 22<br>9450 Altstätten<br>Schweiz<br>Tel. +41/71 / 7 57 22 11<br>Telefax +41/71 / 7 57 22 22<br>wagner@wagner-group.ch  | <b>F</b>  | J. Wagner France S.a.r.l<br>Parc de Gutenberg - Bâtiment F 8<br>8 voie la Cardon,<br>91127 Palaiseau Cedex<br>France<br>Tel. +33/1/825 011 111<br>Telefax +33/1/698 172 57<br>division.batiment@wagner-france.fr | <b>NL</b> | Wagner Spraytech Benelux b.v.<br>Zonneban 10,<br>3542 EC Utrecht<br>Netherlands<br>Tel. +31/ 30/241 41 55<br>Telefax +31/ 30/241 17 87<br>info@wagner-wsb.nl            |
| <b>D</b>  | J. Wagner GmbH<br>Otto-Lilienthal-Straße 18<br>D-88677 Markdorf<br>Postfach 11 20<br>D-88669 Markdorf<br>Deutschland<br>Tel.: +49 / 75 44 / 505 -1664<br>Fax: +49 / 75 44 / 505 -1155<br>wagner@wagner-group.com<br>www.wagner-group.com | <b>CZ</b> | Wagner, spol. s r.o.<br>Nedasovská str. 345<br>155 21 Praha 5 -Zlčín<br>Czechia<br>Tel. +42/ 2 / 579 50 412<br>Telefax +42/ 2 / 579 51 052<br>info@wagner.cz   | <b>S</b>  | Wagner Spraytech<br>Scandinavia A/S<br>Helgeshøj Allé 28<br>2630 Taastrup<br>Denmark<br>Tel. +45/43/ 21 18 18<br>Telefax +45/43/ 43 05 28<br>wagner@wagner-group.dk     |

[www.wagner-group.com](http://www.wagner-group.com)