

Telecommunication Peripheral Products  
**Technical Practice**

**MLC-24**  
Message Waiting  
Lamp Controller  
March 2, 1998

## Add Message Waiting Lamps for Voice Mail....On any Telephone System!



With Viking's **MLC-24** you can integrate visual message waiting indication with nearly any phone system...even those phone systems which do not support message lamps.

The **MLC-24** is compatible with virtually any voice messaging system with "out call" or "dispatch" feature. It can also be activated manually from a Touch Tone phone. The lamps can be reset by the voice mail system or from the user's telephone.

Commands are sent to the controller via C.O. line or analog PABX/KSU station or trunk port. Up to four **MLC-24** controllers can be connected to a single line.

<http://www.VikingElectronics.com>

[E-mail...Sales@VikingElectronics.com](mailto:Sales@VikingElectronics.com)

### Features

- Each MLC-24 controls up to 24 message waiting lamps
- Compatible with 90 to 125V message waiting phones
- Compatible with LED's or Viking **LM-1** or **LM-2** retrofit message waiting lamp kit
- Displays both steady lamp or flash for urgent messages
- Expandable in multiples of 24 lamps
- Uses existing C.O. lines or analog PABX/KSU stations
- Built in diagnostics to aid installer

**Made in the U.S.A.**

### Applications

- Voice mail systems that don't provide message waiting voltage
- Remote voice mail systems
- Staff "In - Out" board
- "Do Not Disturb" lights

**Sales...(715) 386 - 8861**

### Specifications

**Power:** 120V AC/13.8V AC 1.25A, UL listed, adapter provided  
**Dimensions:** 8.25mm x 160mm x 44mm (8.25" x 6.25" x 1.75")  
**Shipping Weight:** 1.36 kg (3 lbs.)  
**Environmental:** 0°C to 32°C (32°F to 90°F) with 5% to 95% non-condensing humidity  
**Connections:** (1) RJ21X male, (1) RJ21X female, (1) RJ11 com port

# Installation

## A. Centrex or PABX Installation with Standard Phones

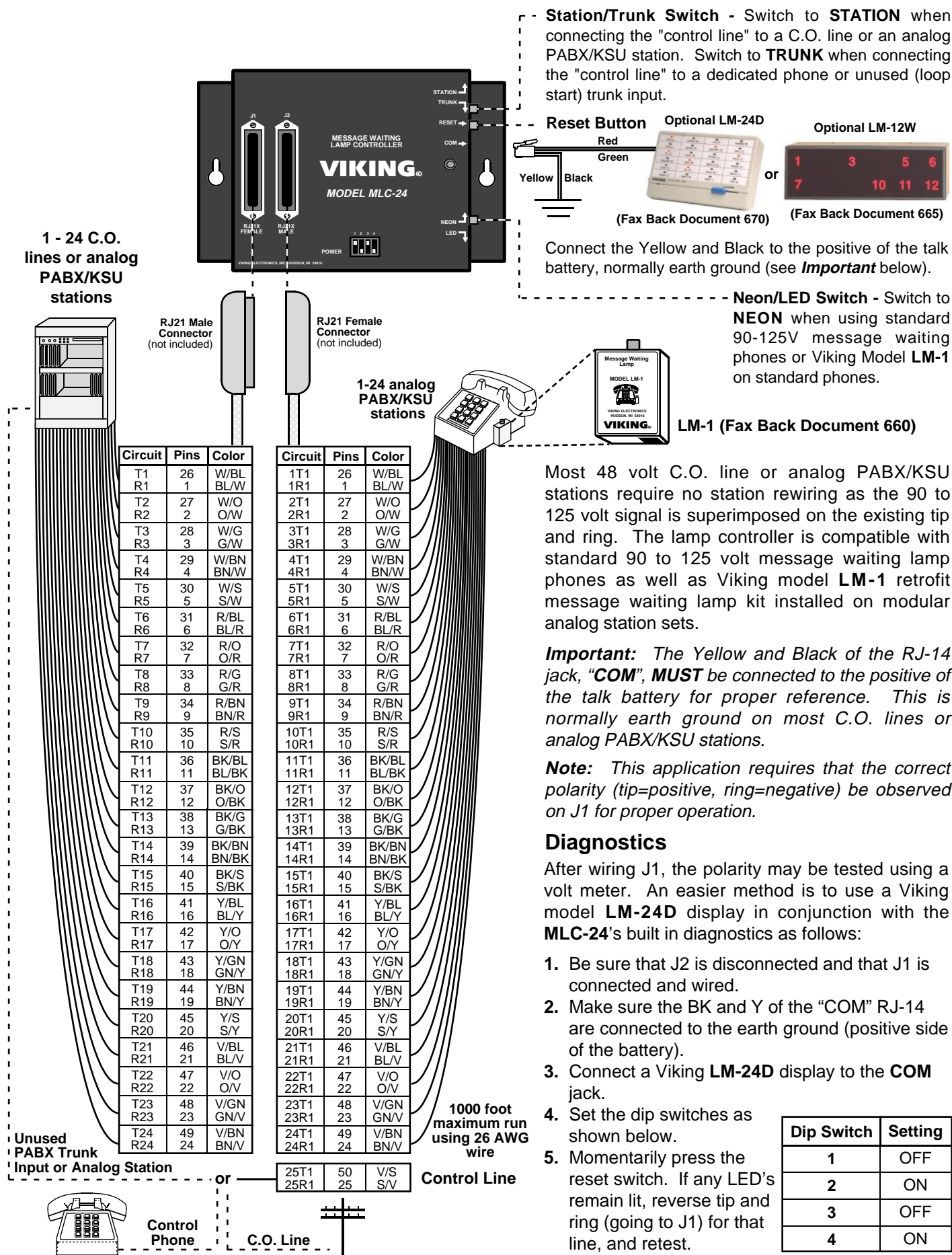

## B. Electronic or Digital Phone Installation with LM-2 Message Waiting Lamps

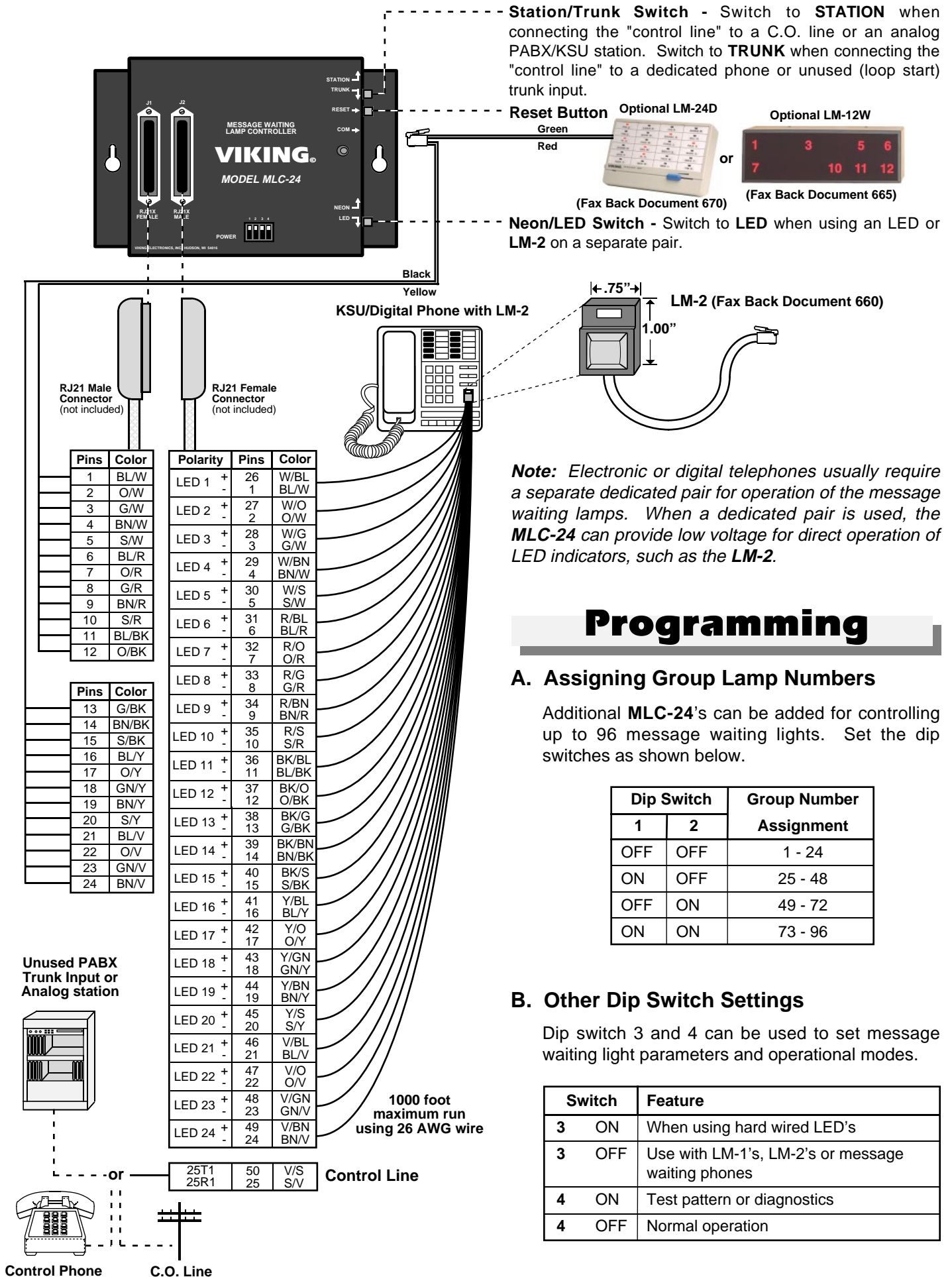

# Operation

A control phone connected directly to the **MLC-24**'s "control line" controls the lamps. The "control line" may also be connected to a C.O. line, analog PABX/KSU station, or an unused C.O. port.

One **MLC-24** controller can serve 24 different station lamps, plus up to three 24 line status displays (**LM-24D** or **LM-12W**) for the receptionist(s). Up to four **MLC-24**'s can be installed on a single extension or line.

In voice mail applications the "dispatch" or "out-call" feature is used to call the extension assigned to the **MLC-24**, which answers and provides a 500 Hz tone. The voice mail system then sends a three digit DTMF code that specifies the status of an individual lamp. For example, a Touch Tone code of "1, 24" would cause lamp 24 to be off, a "2, 24" would cause it to be on steady, a "3, 24" would cause it to flash and a "4, 24" would cause it to fast flash. When the three digit code is complete, the **MLC-24** hangs up. The 3 digit code can also be entered manually from any Touch Tone phone.

In applications where a ringing extension is not available, the **MLC-24** can be programmed to provide talk battery for direct connection to an unused trunk input, a standard DTMF phone or the voice mail "dispatch" or "out-call" port, if compatible.

## A. On Premise Operation

When the **MLC-24** is connected to a station circuit of a PABX, the voice mail system or user must first dial the station (extension) number connected to the **MLC-24**'s "control line." The **MLC-24** will answer with a steady tone. The command codes can then be entered as shown in the table to the right.

Signaling the MLC-24...	Enter Digits
1. ...to turn lamp OFF at station xy*	1 + xy*
2. ...to turn lamp ON at station xy*	2 + xy*
3. ...to flash a lamp at station xy*	3 + xy*
4. ...to fast flash a lamp at station xy*	4 + xy*
5. ...to turn all lamps OFF	1 - 4 + 99

\* xy refers to numbers 1 - 96

## B. Off Premise Operation

When the **MLC-24** is located in a remote facility, the voice mail system or user must call the telephone number of the phone line connected to the "control line" of the **MLC-24** (J2 Pins 25, 50). The **MLC-24** will answer with a steady tone. The command codes can then be entered as shown in the table.

## C. Message Waiting Lamp Illumination

### 1. Neon Message Waiting Phones and/or LM-1 Modular Message Waiting Lamp Retrofit Kit

This kit will illuminate when the receiver is on-hook. They will go out when the receiver is off-hook and go on as the receiver is returned on-hook. The lamp may be extinguished by an off Touch Tone code or by momentarily (.25 - 2 seconds) going off hook.

### 2. LM-2 LED Message Waiting Lamp Kit

This kit will illuminate immediately and remain on until the **LM-2** switch is depressed momentarily (.25 - 2 seconds) or an off Touch Tone code is issued to extinguish the LED.

### 3. LED's

These will illuminate immediately and remain on until an "off" Touch Tone code is issued to extinguish the LED.

## D. Power Failure

In the event of AC power failure, the message waiting lamps will not function. All telco operations will operate as normal.

## E. Special Features

1. With switch positions 1 and 3 in the OFF position and 2 and 4 in the ON position, the display will indicate on or off hook condition for 24 lines (off-hook = LED is on, on-hook = LED is off). **Note:** Depress the reset button on the **MLC-24** after changing switch positions.
2. With switch positions 2 and 3 in the "off" position and 1 and 4 in the "on" position, the installer can generate a test pattern that will aid in the installation. The **MLC-24** will turn the lamps on one at a time, then turn them all off. This will continue until the switches are placed back into position for normal operation.

**Product Support Line...(715) 386-8666**

**Fax Back Line...(715) 386-4345**

Due to the dynamic nature of the product design, the information contained in this document is subject to change without notice. Viking Electronics, its affiliates and/or subsidiaries assume no responsibility for errors and/or omissions contained in this information. Revisions of this document or new editions of it may be issued to incorporate such changes.