

Please visit our web site at:
www.VeriluxStore.com
Call our Customer
Service Department at
1-888-544-4865

(Representatives are available
Monday - Friday, 9 AM - 5 PM Eastern)



Research Park
9 Viaduct Road
Stamford, CT 06907

VT01-MAN-Rev1

Printed in China for: Verilux, Inc.
© Copyright 2005 Verilux, Inc. All rights reserved.

HappyLite® Mini | PLUS

Mood Enhancement System

VT01

WARRANTY

One-Year Limited Warranty

This limited warranty is provided by:

Verilux, Inc., Research Park, 9 Viaduct Road, Stamford, CT 06907

Verilux® warrants this product to be free of defects in materials and workmanship for a period of one year from the invoice date of original retail purchase. During the limited warranty period, Verilux® will, at its option, repair or replace defective parts of this product, at no charge to you, subject to the following limitations. This warranty does not include any postage, freight, transportation, insurance, or delivery fee. This limited warranty does not cover damage, defect, or failure caused by or resulting from accidents, external destruction, alteration, modification, abuse, misuse, or misapplication.

ATTENTION: When returning a product, be aware that damage during shipping is the responsibility of the purchaser and will void any warranty claim. We recommend that you insure the shipment by shipper when returning this product or any parts. Be sure to return product in original packaging.

Note: Verilux® recommends using a quality surge suppressor on all electronics equipment. Voltage variations and spikes can damage electronic components in any system. A quality suppressor can eliminate the vast majority of failures attributed to surges and may be purchased at electronics stores.

Due to ongoing improvements, actual product may have slight variations from the product described in this manual.

TROUBLESHOOTING

Before requesting service on your Verilux® lamp please read the following:

- Make sure all power connectors, cords, and plugs are inserted fully and securely.
- Be sure the bulb is securely seated in the socket. (See page 6)
- Make sure there is power to the wall outlet or try another outlet – not connected to a dimmer.

PROBLEM	CHECK	SOLUTION
Light won't come on	Has the plug come loose?	Insert plug securely into wall outlet.
	Is the bulb old?	Check the bulb for blackening/darkening at the ends (an indicator of bulb life) and replace bulb. See www.VeriluxStore.com .
	Is the bulb connected securely to the socket?	Be sure the bulb is securely seated into the socket, repeat the bulb installation process.
	Is the bulb new?	Sometimes when a new bulb is turned on for the first time the ends will darken, but this will fade after a few minutes.
Blackening/darkening at ends of bulb	Is the bulb old?	With older bulbs darkening of the ends indicates end of bulb life. This doesn't affect operation except to reduce the amount of light available since the phosphor in that area has become inactive). Bulb replacement is recommended.
Light flickers	Has the plug come loose?	Insert plug securely into wall outlet.
	Is the bulb connected securely to the socket?	Be sure the bulb is securely seated into the socket, repeat the bulb installation process.
	Is the lamp connected to a dimmer switch?	Connect lamp plug only to wall outlet without a dimmer switch.

CARE & CLEANING

Your Verilux® lamp is made from high quality materials that will last for many years with a minimum of care.

Clean only with a soft dry cloth – **DO NOT USE SOLVENTS OR CLEANERS CONTAINING ABRASIVES OR AMMONIA**



WARNING: To prevent risk of shock or personal injury when cleaning lamp, make sure you have turned off and unplugged the lamp, and allow sufficient time for the bulb to cool.



Dear Customer,

Thank you for purchasing the Verilux® HappyLite® Mini Plus Mood Enhancement System. You have received an innovative and quality manufactured product, backed by a one-year limited warranty. As a Verilux® customer, your satisfaction means everything to us. We look forward to serving you now and in the future.

Many other healthy lighting products are available through our catalog and online. To request a free copy of our catalog, call our toll-free number 1-888-544-4865. You may also visit us on the web at www.VeriluxStore.com to learn more about all our quality Verilux® products.

Have a Bright Day!

Nicholas Harmon

Nicholas Harmon
President and CEO

IMPORTANT SAFETY INSTRUCTIONS

CAUTION:

- TO REDUCE THE RISK OF ELECTRIC SHOCK, DO NOT DISMANTLE. THERE ARE NO SERVICEABLE PARTS INSIDE.
- TO REDUCE THE RISK OF FIRE OR ELECTRIC SHOCK, DO NOT EXPOSE THIS UNIT TO RAIN OR MOISTURE.



The exclamation point within an equilateral triangle alerts the user to the presence of important operating and maintenance instructions in this owner's guide.

WARNING: TO REDUCE THE RISK OF FIRE, ELECTRIC SHOCK OR PERSONAL INJURY:

- Turn off/unplug and allow to cool before replacing bulb or cleaning.
- Light bulbs get HOT quickly! Do not touch the bulb while the lamp is on.
- Do not look directly at the lighted bulb without the diffuser being in place.
- Do not operate the lamp in close proximity to flammable or combustible vapors, such as aerosol (spray) products or where oxygen is being administered.
- Use only the type of bulb and maximum wattage indicated by Verilux®.
- Never cover the lamp when it is in operation.

BULB REPLACEMENT

Bulb removal and replacement

1. Unplug lamp from power source.
2. To access the bulb, remove the plastic diffuser by depressing the tabs (D) and lifting it out.
3. Firmly hold the bulb base (B) (Do not hold the glass portion of the bulb) and pull bulb from the socket in an outward motion (rocking slightly if needed).
4. To re-install bulb and plastic diffuser, see instructions on page 6

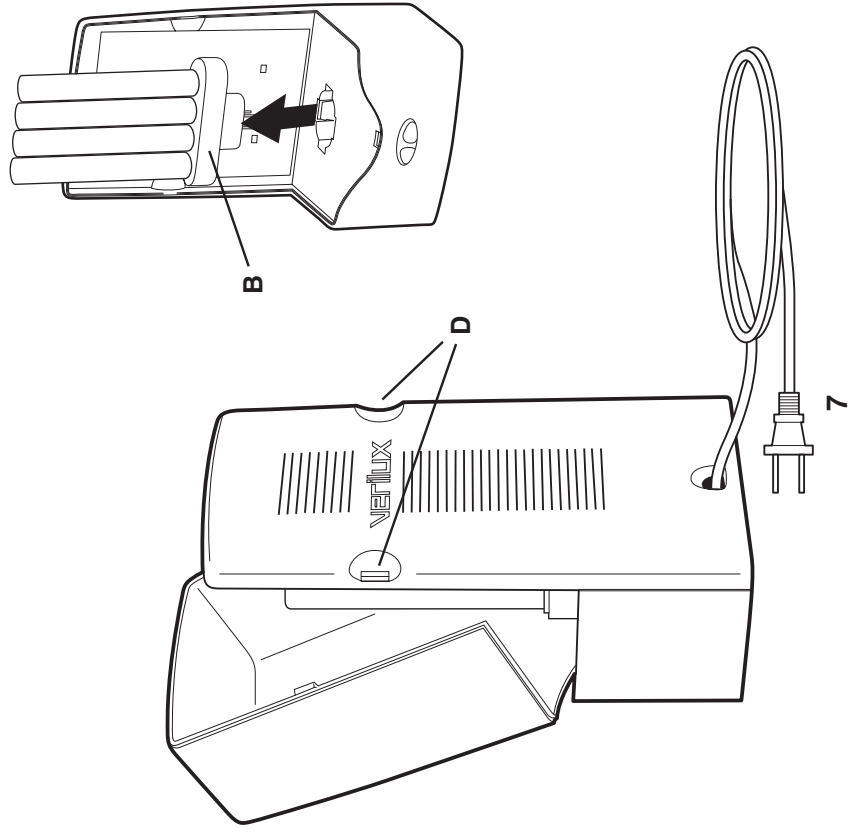

SET-UP INSTRUCTIONS

Bulb & Diffuser Installation

1. Insert bulb into lamp by firmly holding bulb base and push into the socket (See below)

Note: Make sure bulb is fully inserted into the socket. The bottom of the bulb base should touch the plastic housing of the lamp.

2. Attach the plastic diffuser to the lamp body by first inserting the tab located at the bottom of the diffuser (A) into the opening of the lamp base (B).
3. Rotate the plastic diffuser and align the side snap tabs (C) into position – press firmly to snap parts together.

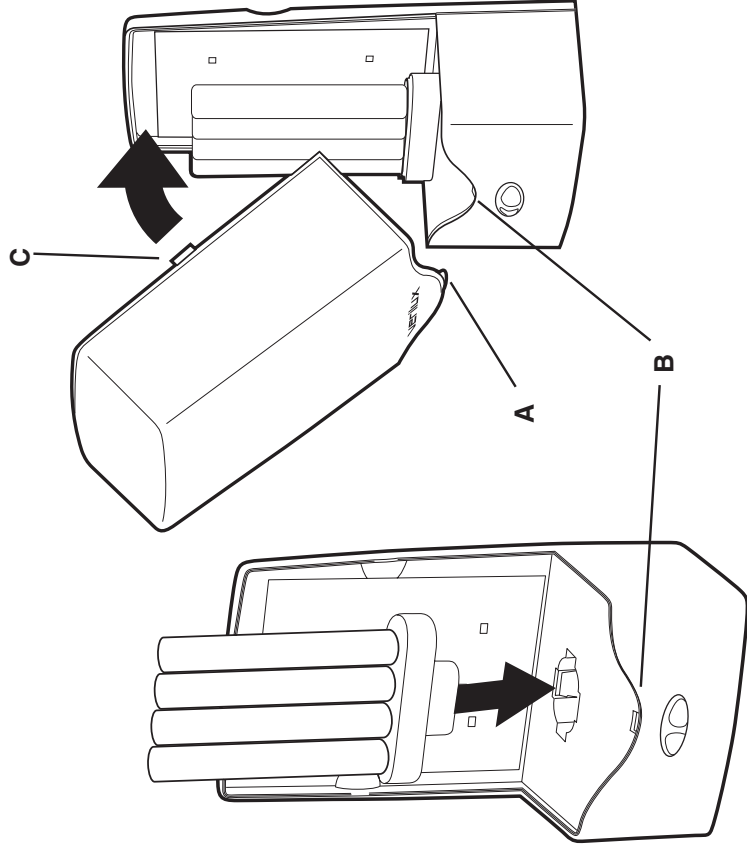

6

IMPORTANT SAFETY INSTRUCTIONS

1. Read these instructions – before using this lamp.
2. Keep these instructions – for future reference.
3. Heed all warnings.
4. Follow all instructions.
5. Do not use this lamp in damp/humid or wet locations.
6. For indoor use only.
7. Clean only with dry cloth.
8. Do not block any ventilation openings.
9. Do not place near any heat sources such as radiators, heat registers, stoves, or other apparatus (including amplifiers) that produce heat.
10. Do not defeat the safety purpose of the polarized plug. A polarized plug has two blades with one wider than the other. The wider blade is provided for your safety. If the provided plug does not fit in your outlet, consult an electrician for replacement of the obsolete outlet.
11. Protect the power cord from being walked on or pinched particularly at plugs, convenience receptacles, and the point where it exits from the lamp.
12. Only use attachments/accessories specified by the manufacturer.
13. Unplug this lamp during lightning storms or when unused for long periods of time.
14. If the lamp has been damaged in any way, such as power-supply cord or plug is damaged, liquid has been spilled or objects have fallen onto the lamp, the lamp has been exposed to rain or moisture, does not operate normally, or has been dropped, it should not be operated. There are no user serviceable parts within this lamp.

SAVE THESE INSTRUCTIONS

3

GENERAL PRECAUTIONS

- Do not use with power supply voltage other than 120V AC
- Avoid placing the lamp in areas that are dusty, humid/moist, lack ventilation, or are subject to constant vibration.
- Not for use with light dimmers, timers, motion detectors, voltage transformers, or extension cords.
- Do NOT use lubricating agent in bulb assembly.
- Close supervision is recommended when this lamp is used by or near children, or others who may not understand the need for these precautions. Do not leave the lamp unattended during use.

This product may cause interference with radios, cordless telephones, or devices that use a wireless remote control, such as televisions.

This lamp has been tested and found to comply with Part 18 of the FCC Rules. These limits are designed to provide reasonable protection against harmful interference in a residential installation. This lamp generates, uses, and can radiate radio frequency energy and, if not used in accordance with the instructions, may cause harmful interference to radio communications. If interference occurs try to correct the interference by one or more of the following measures:

- Reorient or relocate the receiving antenna.
- Increase the separation between the lamp and receiver.
- Connect the lamp into an outlet on a circuit different from that to which the receiver is connected.
- Move the lamp out of the line of sight of the remote control receiver.
- Consult the dealer or an experienced radio/TV technician for help.

Note: This product may cause interference to radio equipment and should not be installed near maritime safety communications equipment or other critical navigation or communication equipment operating between 0.45-30 MHz.

SET-UP INSTRUCTIONS

Unpacking

Please remove all packaging material. Check the carton for the items pictured below:

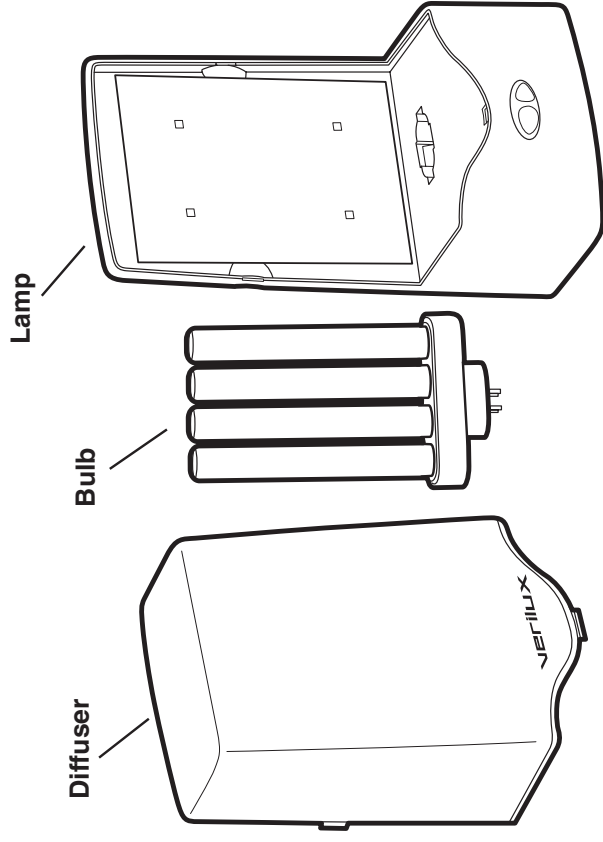

Selecting a location

- Place your Verilux® HappyLite® Mini Plus Mood Enhancement System on a table or other flat surface.
- For best performance, place the lamp within two feet of you.

Note: Avoid placing this lamp in areas that are exposed to direct sunlight or close to heat-radiating products, such as heaters. Do not place the lamp on the top of appliances that radiate heat.



WARNING: DO NOT BLOCK VENTS

Vents are necessary for proper function of the electronic ballast; blocking them may cause overheating of the electronics and increase risk of fire.