



**INSTALLATION MANUAL FOR  
 TCGR DISPLAY CASES (REFRIGERATED BAKERY & COLD DELI) MODELS**



**TCGR-50-CD**



**TCGR-50**



**TCGR-77**

**TABLE OF CONTENTS**

- ▶ **Safety Information**
  - Safety Precautions** \_\_\_\_\_ 1
  - Proper Disposal** \_\_\_\_\_ 2
  - Connecting Electricity** \_\_\_\_\_ 3
  - Adapter Plugs** \_\_\_\_\_ 3
- ▶ **Installation / Operation Instructions**
  - Ownership** \_\_\_\_\_ 4
  - Required Tools** \_\_\_\_\_ 4
  - Uncrating** \_\_\_\_\_ 4
  - Locating** \_\_\_\_\_ 5
  - Leveling Cabinet** \_\_\_\_\_ 5
  - Electrical Instructions** \_\_\_\_\_ 6
  - Wire Gauge Chart** \_\_\_\_\_ 7
  - Start-up** \_\_\_\_\_ 8
  - Shelving Installation** \_\_\_\_\_ 9-10
  - Installing Optional Castors** \_\_\_\_\_ 11
  - Installing Optional Formica Kit** \_\_\_\_\_ 12
- ▶ **Maintenance, Care & Cleaning**
  - Optional Sealing Cabinet To Floor** \_\_\_\_\_ 13
  - Cabinet Cleaning** \_\_\_\_\_ 13
  - Light Bulb Replacement** \_\_\_\_\_ 14
  - Temperature Control Adjustment** \_\_\_\_\_ 15
  - Cleaning The Condenser** \_\_\_\_\_ 16
  - Important Warranty Information** \_\_\_\_\_ 17
  - Stainless Steel Equipment Care and Cleaning** \_\_\_\_\_ 18-19
  - Warranty (U.S.A. and Canada ONLY!)** \_\_\_\_\_ 20

*\*Spanish, German, French, and Dutch versions included.*

**CONGRATULATIONS!**  
*You have just purchased the finest commercial refrigeration available. You can expect many years of trouble-free operation.*

**CURVED GLASS DISPLAY CASES  
 - REFRIGERATED BAKERY & COLD DELI -**

# NOTICE TO CUSTOMER:



**Loss Or Spoilage Of Products  
In Your Refrigerator/Freezer  
Is NOT Covered By Warranty.  
In Addition To Following  
Recommended Installation  
Procedures You Must Run  
The Refrigerator/Freezer  
24 Hours Prior To Usage.**

True Manufacturing Company, Inc.

SAFETY INFORMATION

# **How to Maintain Your *TRUE*® Unit to Receive the Most Efficient and Successful Operation**

*You have selected one of the finest display cases made. It is manufactured under strict quality controls with only the best quality materials available. Your TRUE cooler, when properly maintained, will give you many years of trouble-free service.*

## **WARNING!**

***Use this appliance for its intended purpose as described in this Owner Manual.***

### **SAFETY PRECAUTIONS**

*When using electrical appliances, basic safety precautions should be followed, including the following:*

- This display case must be properly installed and located in accordance with the Installation Instructions before it is used.
- Do not allow children to climb, stand or hang on the shelves in the display case. They could damage the refrigerator and seriously injure themselves.
- Do not touch the cold surfaces in the refrigerated compartment when hands are damp or wet. Skin may stick to these extremely cold surfaces.
- Do not store or use gasoline or other flammable vapors and liquids in the vicinity of this or any other appliance.
- Keep fingers out of the “pinch point” areas; clearances between the doors and between the doors and cabinet are necessarily small; be careful closing doors when children are in the area.

***NOTE: We strongly recommend that any servicing be performed by a qualified individual.***

- Unplug the refrigerator before cleaning and making repairs (switch power off at breaker for hard wired models).
- Setting temperature controls to the 0 position does not remove power to the light circuit, perimeter heaters, or evaporator fans.

SAFETY INFORMATION

**DANGER!**  
**RISK OF CHILD ENTRAPMENT**

**PROPER DISPOSAL OF THE DISPLAY CASE**

---

Child entrapment and suffocation are not problems of the past. Junked or abandoned display cases are still dangerous... even if they will sit for “just a few days.” If you are getting rid of your old display case, please follow the instructions below to help prevent accidents.

**Before You Throw Away Your Old Display Case:**

- **Take off the doors.**
- **Leave the shelves in place so that children may not easily climb inside.**

**Refrigerant Disposal**

Your old refrigerator may have a cooling system that uses “Ozone Depleting ” chemicals. If you are throwing away your old refrigerator, make sure the refrigerant is removed for proper disposal by a qualified service technician. If you intentionally release any refrigerants you can be subject to fines and imprisonment under provisions of the environmental regulations.

**USE OF EXTENSION CORDS**

---

**NEVER USE AN EXTENSION CORD! TRUE will not warranty any display case that has been connected to an extension cord.**

SAFETY INFORMATION

# WARNING!

## HOW TO CONNECT ELECTRICITY

**Hard wiring is required on specific Display Cases.**

**Models standard with power cords: Do not, under any circumstances, cut or remove the third (ground) prong from the power cord.**

**For personal safety, this appliance must be properly grounded.**

Before your new display case is connected to a power supply, check the incoming voltage with a voltmeter. If anything less than 100% of the rated voltage for operation is noted, correct immediately.

Have the circuit checked by a qualified electrician to make sure it is properly grounded.

The display case should always be use it's own individual electrical circuit, which has a voltage rating that matches the rating plate.

This provides the best performance and also prevents overloading building wiring circuits which could cause a fire hazard from overheated wires.

**For models with standard power cord.**

The power cord of this appliance is equipped with a 3-prong (grounding) plug which mates with a standard 3-prong (grounding) wall outlet to minimize the possibility of electric shock hazard from this appliance.

Have the circuit checked by a qualified electrician to make sure it is properly grounded.

If the outlet is a standard 2-prong outlet, it is your personal responsibility and obligation to have it replaced with the properly grounded 3-prong wall outlet.

The display case should always be plugged into it's own individual electrical circuit, which has a voltage rating that matches the rating plate.

This provides the best performance and also prevents overloading building wiring circuits which could cause a fire hazard from overheated wires.

Never unplug your display case by pulling on the power cord. Always grip plug firmly and pull straight out from the outlet.

Repair or replace immediately all power cords that have become frayed or otherwise damaged. Do not use a cord that shows cracks or abrasion damage along its length or at either end.

When removing the display case away from the wall, be careful not to roll over or damage the power cord.

## USE OF ADAPTER PLUGS

**NEVER USE AN ADAPTER PLUG! Because of potential safety hazards under certain conditions, we strongly recommend against the use of an adapter plug.**

**NOTE**

**Hard wired models do not use this receptacle.**

NEMA plugs

TRUE uses these types of plugs. If you do not have the right outlet have a certified electrician install the correct power source.



115/60/1  
NEMA-5-20R

INSTALLATION / OPERATION INSTRUCTIONS

**INSTALLATION / OPERATION INSTRUCTIONS**

**OWNERSHIP**

To insure that your unit works properly from the first day, it must be installed properly. We highly recommend a trained mechanic and electrician install your True equipment. The cost of a professional installation is money well spent.

Before you start to install your True unit, carefully inspect it for freight damage. If damage is discovered, immediately file a claim with the delivery freight carrier.

**True is not responsible for damage incurred during shipment.**

**REQUIRED TOOLS**

- Tin Snips / Band Cutters
- Claw Hammer
- Hex Head Driver
- Adjustable Wrench
- 3/4" (19 mm) Open-End Wrench
- Phillips Head Screwdriver
- Level

**UNCRATING**

**Step 1**

The following procedure is recommended for uncrating the unit:

- A.** Cut metal retaining straps securing protective top skid. Remove the outer packaging by pulling tri-wall nails from skid. Remove (4) cardboard corner pads and dust cover.
- B.** Inspect for concealed damage. Again, immediately file a claim with the freight carrier if there is damage.
- C.** Move your display case as close to the final location as possible before removing the wooden skid.

**REMOTE UNITS (This section applies to remotes only!)**

- Remote cabinets must be ordered as remote. We do not recommend converting a standard self contained to remote system.
- All remote cabinets must be hard wired.
- Remote cabinets are not available with castors.
- All remote cabinets come standard using 404A refrigerant.
- All remote units come standard with expansion valve, liquid line solenoid, heated condensate pan, and defrost timer when applicable.
- Contact True Technical Service for BTU requirements.
- No wiring necessary between cabinet and condensing unit.
- All remote condensing units purchased from True are 208/230 volts single phase.

If you have any questions regarding this section, please call True at 1 (800) 325-6152.

INSTALLATION / OPERATION INSTRUCTIONS

**LOCATING**

**TOOLS REQUIRED:**

- Phillips screw driver
- 3/8" (9.5 mm) socket or 3/8" (9.5 mm) wrench

**Step 2**

**A.** Use a Phillips screw driver and remove four screws from the L-bracket connected the unit to the wood skid (image 1). Then use a 3/8" (9.5 mm) socket or wrench and remove the L-bracket from the unit (image 2).

To avoid damage to glass **DO NOT** lay cabinet on its side or back when removing skid, installing leg levelers, cleaning, etc.

- B.** Lift up from the base and walk unit off the skid and set in final location.
- C.** Unblock doors, (free plastic wedges, blue foam and tape. Remove fiberglass tape securing glass. Remove components: (shelves, brackets, etc.) from inside cabinet.



**1**  
Removing bracket from skid.



**2**  
Removing bracket from cabinet.

**LEVELING**

**Step 3**

**A.** Set unit in its final location. Be sure there is adequate ventilation in your room. Under extreme heat conditions, (100°F+, 38°C+), you may want to install an exhaust fan.

**Warning**

**Warranty is void if ventilation is insufficient.**

**B.** Proper leveling of your True unit is critical to operating success (for non-mobile models). Effective condensate removal and door operation will be effected by leveling.

**Warning**

**Display case must be leveled accurately to ensure front glass door seals properly.**

**C.** The unit should be leveled front to back and side to side with a level. Place the level in the interior floor of the unit and check all four sides.

**D.** If the cabinet is not level adjust leg levelers by first relieving weight to leveler and adjusting by either hand or wrench. Repeat with all leg levelers until cabinet is level in all directions.

**E.** Ensure that the drain hose or hoses are positioned in the pan.

**F. Models with power cord:** Free plug and cord from inside the lower rear of the cooler (do not plug in).

**G. Models with power cord:** The unit should be placed close enough to the electrical supply so that extension cords are never used.

**Warning**

**Compressor warranties are void if the unit is more than 9 ft. (3 m) from plug-in connection or an extension cord is used to connect unit to a power supply.**

## **ELECTRICAL INSTRUCTIONS**

---

### **Step 4**

#### **NOTE**

**Hard wiring for a 30 amp circuit is required on specific Bakery Cases.**

- A.** Before your new unit is connected to a power supply, check the incoming voltage with a voltmeter. If anything less than 100% of the rated voltage for operation is noted, correct immediately.
- B.** Models equipped with 9 ft. (3 m) power cord must be powered at proper operating voltage at all times.  
  
Refer to cabinet data plate for voltage.  
  
True requires that a sole use circuit be dedicated for the unit.

#### **WARNING**

**Compressor warranties are void if compressor burns out due to low voltage.**

#### **WARNING**

**Power supply cord ground should not be removed!**

#### **NOTE**

**To reference wiring diagram - Remove lower rear grill. Wiring diagram is positioned on the ballast box inside lower rear of the cabinet.**



INSTALLATION / OPERATION INSTRUCTIONS

**CONDUCTORS AND CIRCUITS**

**Wire Gauge for 2% Voltage Drop in Supply Circuits.**

115 Volt Amps	Distance In Feet To Center of Load											
	20	30	40	50	60	70	80	90	100	120	140	160
2	14	14	14	14	14	14	14	14	14	14	14	14
3	14	14	14	14	14	14	14	14	14	14	14	12
4	14	14	14	14	14	14	14	14	14	12	12	12
5	14	14	14	14	14	14	14	12	12	12	10	10
6	14	14	14	14	14	14	12	12	12	10	10	10
7	14	14	14	14	14	12	12	12	10	10	10	8
8	14	14	14	14	12	12	12	10	10	10	8	8
9	14	14	14	12	12	12	10	10	10	8	8	8
10	14	14	14	12	12	10	10	10	10	8	8	8
12	14	14	12	12	10	10	10	8	8	8	8	6
14	14	14	12	10	10	10	8	8	8	6	6	6
16	14	12	12	10	10	8	8	8	8	6	6	6
18	14	12	10	10	8	8	8	8	8	8	8	5
20	14	12	10	10	8	8	8	6	6	6	5	5
25	12	10	10	8	8	6	6	6	6	5	4	4
30	12	10	8	8	6	6	6	6	5	4	4	3
35	10	10	8	6	6	6	5	5	4	4	3	2
40	10	8	8	6	6	5	5	4	4	3	2	2
45	10	8	6	6	6	5	4	4	3	3	2	1
50	10	8	6	6	5	4	4	3	3	2	1	1

**Wire Gauge for 2% Voltage Drop in Supply Circuits.**

230 Volt Amps	Distance In Feet To Center of Load											
	20	30	40	50	60	70	80	90	100	120	140	160
5	14	14	14	14	14	14	14	14	14	14	14	14
6	14	14	14	14	14	14	14	14	14	14	14	12
7	14	14	14	14	14	14	14	14	14	14	12	12
8	14	14	14	14	14	14	14	14	14	12	12	12
9	14	14	14	14	14	14	14	14	12	12	12	10
10	14	14	14	14	14	14	14	12	12	12	10	10
12	14	14	14	14	14	14	12	12	12	10	10	10
14	14	14	14	14	14	12	12	12	10	10	10	8
16	14	14	14	14	12	12	12	10	10	10	8	8
18	14	14	14	12	12	12	10	10	10	8	8	8
20	14	14	14	12	10	10	10	10	10	8	8	8
25	14	14	12	12	10	10	10	10	8	8	6	6
30	14	12	12	10	10	10	8	8	8	6	6	6
35	14	12	10	10	10	8	8	8	8	6	6	5
40	14	12	10	10	8	8	8	6	6	6	5	5
50	12	10	10	8	6	6	6	6	6	5	4	4
60	12	10	8	6	6	6	6	6	5	4	4	3
70	10	10	8	6	6	6	5	5	4	4	2	2
80	10	8	8	6	6	5	5	4	4	3	2	2
90	10	8	6	6	5	5	4	4	3	3	1	1
100	10	8	6	6	5	4	4	3	3	2	1	1

INSTALLATION / OPERATION INSTRUCTIONS

**STARTUP**

**Step 5**

- A.** The compressor is ready to operate. Plug in the display case.
- B.** Check the temperature control setting in the lower right of the cabinet backside. The setting should be at No. 3 position to maintain an approximate temperature of 38°F (3.3°C). Set defrost time clock to the correct time of day. Allow unit to function several hours, completely cooling cabinet before changing the control setting.
- C.** Excessive tampering with the control could lead to service difficulties. Should it ever become necessary to replace temperature control, be sure it is ordered from your True dealer or recommended service agent.
- D.** Good air flow in your True unit is critical. Be careful not to overstock product or block air vents.
- E.** Verify that the cabinet lights are working. Bakery cases are shipped with light switches in the "on" position. The toggle switch is located lower right corner at the rear.

**NOTE**

*If the unit is disconnected or shut off, wait five minutes before starting again.*

**RECOMMENDATION**

*Before loading product we recommend you run your True unit empty for two to three days. This allows you to be sure electrical wiring and installation are correct and no shipping damage has occurred. Remember, our factory warranty does not cover product loss!*

**REPLACEMENT PARTS**

*TRUE maintains a record of the cabinet serial number for your unit. If at any time during the life of your display case, a part is needed, you may obtain this part by furnishing the model number and serial number to the company from whom you purchased the cabinet. Call Toll-Free: (800)-424-TRUE (Direct to Parts Department). (800)-325-6152 (U.S.A. & Canada only) or call: (636)-240-2400.*

**REFRIGERATED CURVED GLASS  
DISPLAY CASES**

Hard wired Display Cases are equipped with a service receptacle (found on the upper right cabinet backside). No electrical load greater than 4.0 amps should be connected to it.

INSTALLATION / OPERATION INSTRUCTIONS

**SHELVING INSTALLATION (REFRIGERATED BAKERY)**

**SHELF INSTALLATION:**

- A. Lift each door up and out of track (do not disconnect elastic tubing). Stretch elastic surgical tubing and set doors on each side of unit.
- B. Locate brackets, lights, shelves, etc. from cabinet interior.
- C. Locate shelf supports wrapped in micro foam and install teeth end into stainless pilasters located on interior walls. Adjust to desired height matching right and left pairs. (images 1 & 2).

- D. Locate three horizontal lights wrapped in micro foam and install (light side down). Electrical cords should be on the right to plug into side receptacles.

Hang end hooks of light assembly on two shelf supports (left and right) slide assembly forward until it seats in front notch of shelf support. (image 3).

- E. Install rear brackets by sliding end hooks over rear notch of shelf support. (image 4).
- F. Locate shelves, install top shelf first. With the front lip (tray stop) up and towards cabinet front, place on top of front light assembly and snap shelf into (2) clips on top of rear bracket (image 5).

- G. Plug top light assembly into top receptacle of cabinet interior side wall (image 5).
- H. Repeat procedures for remaining two shelves (image 6).

- I. Replace doors in track.

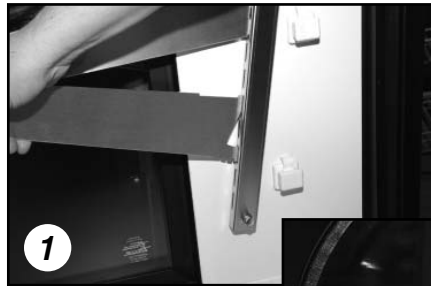

1  
Install shelf supports. teeth end into stainless pilasters.



2  
Adjust to desired height matching right and left pairs.



3  
Hang end hooks of light assembly on front notch of shelf supports.



4  
Install rear brackets.

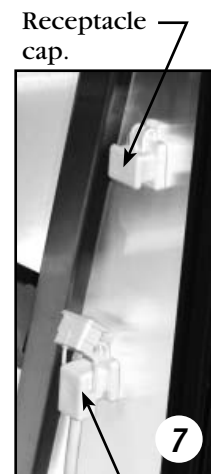

7  
Shelf plug.

**WARNING**

**Shelf mounted lighting requires a closed circuit. All plugs must be plugged into side wall receptacles for lights to work. If less than three shelves are installed be sure attached caps are plugged into receptacle(s) (image 7).**



5  
Snap shelf into position.



6  
Completed assembly.

INSTALLATION / OPERATION INSTRUCTIONS

**SHELVING INSTALLATION (COLD DELI)**

**SHELF INSTALLATION:**

- A.** Lift each door up and out of track (do not disconnect elastic tubing). Stretch elastic surgical tubing and set doors on each side of unit.
- B.** Locate brackets, lights, shelves, etc. from cabinet interior.
- C.** Locate shelf supports wrapped in micro foam and install teeth end into stainless pilasters located on interior walls. Adjust to desired height matching right and left pairs. (images 1 & 2).
- D.** Locate the stainless steel shelf and install with product stop towards the front of the cabinet. Side flaps should overlap shelf support. Be sure to fit shelf support tip into front slot of shelf (images 2 & 3).
- E.** Plug light assembly into any receptacle of cabinet interior side wall (image 4).
- F.** Replace doors in track.

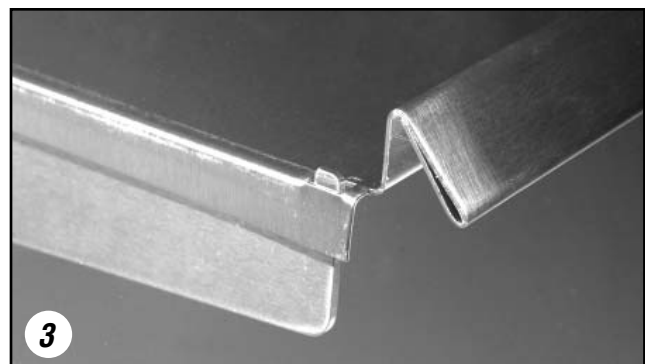
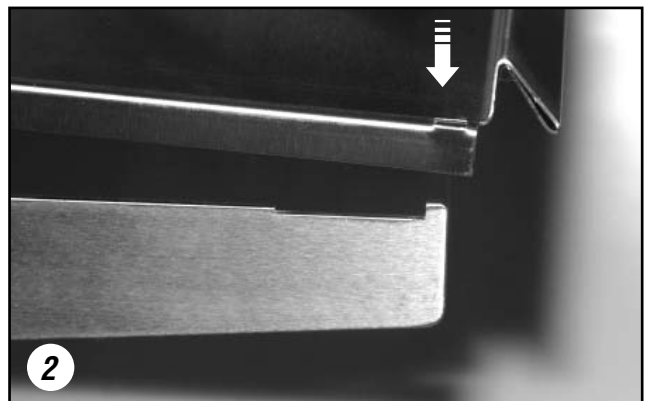

**NOTE**

Three lighting receptacles allow for two additional, "optional", lighted shelves.

**WARNING**

Shelf mounted lighting requires a closed circuit. All plugs must be plugged into side wall receptacles for lights to work. If less than three shelves are installed be sure attached caps are plugged into receptacle(s) (image 4).

INSTALLATION / OPERATION INSTRUCTIONS

**OPTIONAL (INSTALLING OPTIONAL CASTORS)**

**CASTOR INSTALLATION:**

**TOOLS REQUIRED:**

- Castor wrench (if not included contact True)
- Adjustable wrench

**NOTE**

*Castors not available for hard wired or remote models.*

**WARNING**

*Make sure unit is empty of all its contents (shelving, shelving lighting). Make sure power supply has been disconnected.*

- A.** Curved glass can be damaged if you lay unit on its back, side, or front. Use a 6" x 6" (15.2 cm x 15.2 cm) block of wood or equivalent. Slide the block under the cabinet frame rail. This will support the unit while installing castors.
- B.** Leg levelers can be backed out by hand (image 1).
- C.** Take two threaded castors and thread them into the existing leg leveler holes. (image 2). Shims can be used between castor and cabinet frame rail for leveling (image 3). Use the tool provided to tighten the threaded castors (image 4).
- D.** Repeat process for the other side of the cabinet.

**Warning**

*Display case must be leveled accurately to ensure front glass door seals properly.*

- E.** The unit should be leveled front to back and side to side with a level. Place the level in the interior floor of the unit and check all four sides.

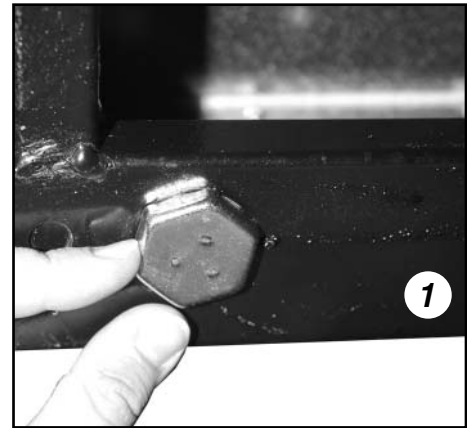

Back out leg levelers by hand, or with adjustable wrench.

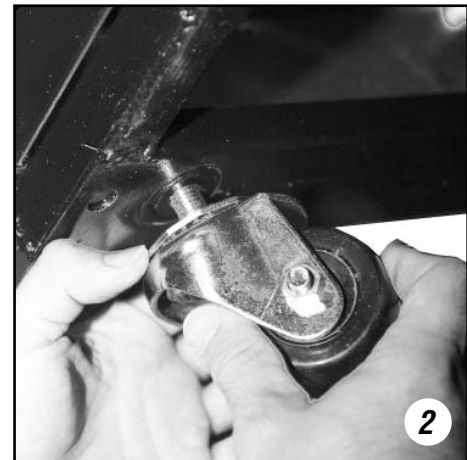

Thread castors into existing leg leveler holes.



Use shims as necessary to level cabinet.



Tighten castor in position with castor wrench.

INSTALLATION / OPERATION INSTRUCTIONS

**OPTIONAL (INSTALLING OPTIONAL FORMICA KIT)**

**FORMICA KIT INSTALLATION:**

**FORMICA KIT COMPONENTS:**

- (2) Formica Top End Panels 10<sup>3</sup>/<sub>4</sub>"w x 33"h (27.3 cm x 83.8 cm).
- (2) Bottom End Panels (1) left side, (1) right side (Formica glued to black plastic panel with 4 key hole slots).
- (1) Formica Front Panel width will vary x 7<sup>5</sup>/<sub>8</sub>"h (19.4 cm)

**NOTE**

*Please use care when installing the Formica. Formica can chip, crack, or break.*

**NOTE**

*Refer to image 1 for placement of Formica panels.*

**A.** Install the front Formica panel.

Be sure bottom end panels are off in order to install front panel. Slide front panel into top and bottom tracks on the front of the cabinet. Make sure panel is even on both left and right end of the cabinet (images 1 & 2).

**B.** Install the top end Formica panels (one on each side).

Be sure bottom end panels are off in order to install top end Formica panel. Both top end panels are the same size so they each can be used for left or right of the cabinet.

Slide panel up into black plastic tracks on the top side panel of each end of cabinet (images 1 & 3).

**NOTE**

*After installing the bottom end pieces the top end panel will stay in place.*

**C.** Install the bottom end Formica panels (one on each side).

(Formica is pre-glued to black plastic panel). Line up the four keyhole slots in each bottom end piece to the (4) screws on the side of the cabinet. Slip the (4) large keyholes from the bottom end piece over the (4) screws. Then push down to fasten the bottom end piece onto the cabinet (images 1 & 3).

**NOTE**

*The bottom left and right pieces are not the same. The taller part of the bottom end piece goes to the rear of the cabinet as shown in image 3.*

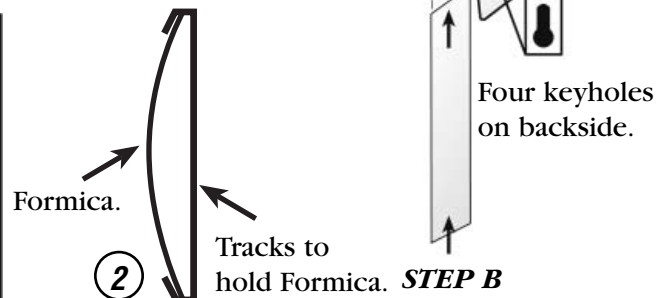
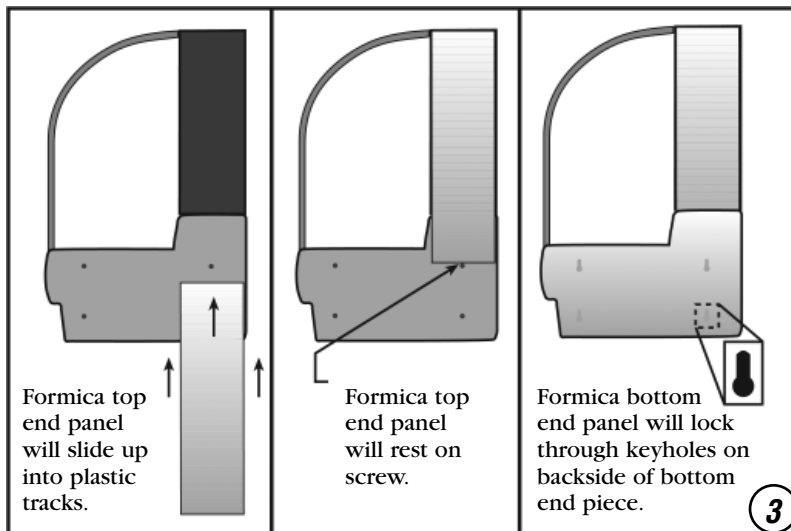
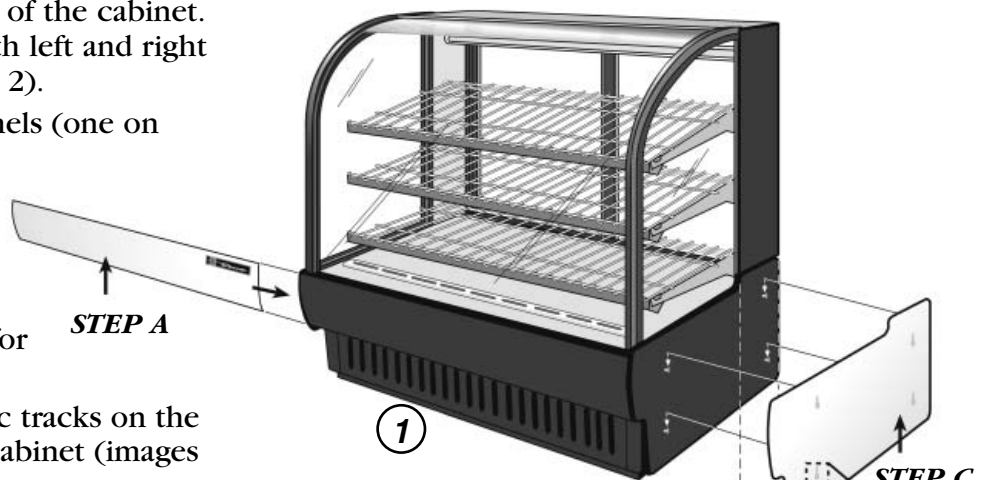

**STEP A**

Side view of Formica sliding into place for front panel and top end panel.

MAINTENANCE, CARE & CLEANING

**OPTIONAL (SEALING CABINET TO FLOOR)**

It may be necessary to seal the bakery case to the floor for local sanitary codes or if the customer so desires. TRUE recommends either of the following methods.

- A. Using a vinyl cove base trim as produced by *Armstrong, Johnson, or Kentile* (available at floor covering suppliers) or  
Using mastics available at hardware stores.
- B. When applying the cove base trim, thoroughly clean both the cabinet and floor of dirt and grease. Apply a recommended contact cement to the cove base trim. After cove base trim has dried, fill in cracks and joints with a caulking

material.

- C. When applying a mastic, thoroughly clean both the cabinet and floor of dirt and grease. Draw an outline of the cabinet on the floor. Raise and block the front side of the cabinet. Apply a bead of mastic to the floor 1/2" (1.3 cm) inside the outline drawn. Lower the cabinet. Raise and block the rear side of the cabinet. Apply the bead of mastic, lower the cabinet.

**CABINET CLEANING**

- The exterior may be wiped clean with mild soap and water. The use of stainless steel cleaners or other such solvents is not recommended on plastic parts. Warm soap and water will suffice.
- *The interior of the display case should be cleaned periodically and we recommend a mild solution of diluted baking soda and water which will help reduce any inherent odors. Do not use harsh cleaners on any surface of the interior.*

**CAUTION:** Do not use any steel wool, abrasive or chlorine based products to clean stainless steel surfaces.

MAINTENANCE, CARE & CLEANING

**LIGHT BULB REPLACEMENT**

**SHELF MOUNTED BULB REPLACEMENT:**

**WARNING**

*When replacing a light bulb make sure power to the unit is either turned off or unplugged.*

- A. Unplug the light assembly from the receptacle on the interior side wall. Remove shelf and light assembly from cabinet.
- B. Remove the lampshield by gently squeezing the sides together and rotating out (image 1).
- C. Remove bulb from the corded end of assembly by holding the bulb and gently pulling up on spring loaded lampholder which will allow enough clearance to remove bulb (image 2).

**NOTE**

*All spring loaded lampholders are located on the left side of the cabinet as you face the front.*

**NOTE**

*Please be aware of your local ordinances for disposal of old florescent bulbs. These bulbs should be disposed of in a safe and proper manner.*

- D. Install new bulb using spring loaded lampholder.
- E. Reinstall light assembly and shelf. Plug cord into side wall receptacle.

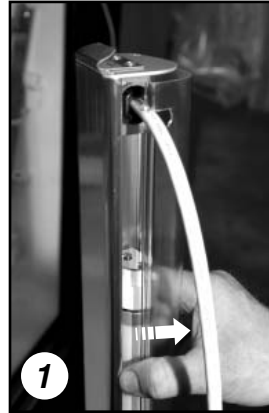

1 Squeeze lampshield and rotate out.

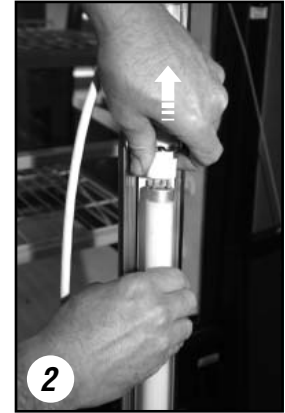

2 Remove bulb by gently pulling up on spring loaded lampholder.

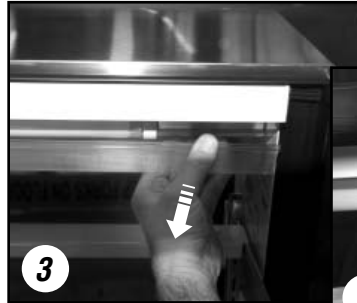

3 Squeeze lampshield and rotate out.

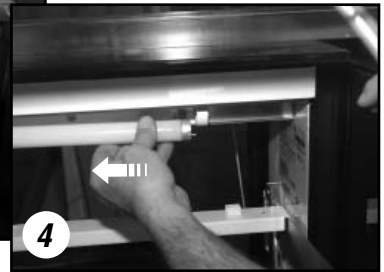

4 Remove bulb by gently pushing bulb into spring loaded lampholder.

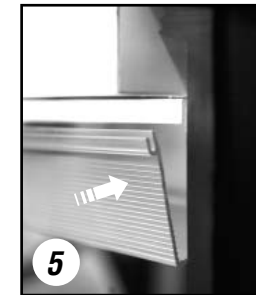

5 Squeeze lampshield "U" channel into position over metal bracket.



6 lampshield "U" channel in position over metal bracket.

**INTERIOR TOP BULB REPLACEMENT:**

**WARNING**

*When replacing a light bulb make sure power to the unit is either turned off or unplugged.*

- A. Remove the lampshield by gently squeezing the sides together and rotating out (image 3).
- B. Remove bulb by gently pushing bulb back into spring loaded lampholder which will allow enough clearance to remove bulb (image 4).
- C. Install new bulb using spring loaded lampholder.
- D. Reinstall light lampshield by sliding rear "U" channel of lampshield over metal bracket and gently squeezing lampshield to fit front "U" channel over front metal bracket (images 5-6).
- E. Image 7 shows assembly properly installed.



7 Interior top light assembly properly installed.



MAINTENANCE, CARE & CLEANING

# TEMPERATURE CONTROL ADJUSTMENT FOR HIGH ALTITUDE ONLY!

**TERMS:**

- Cut-out - Temperature sensed by the controller that shuts the compressor off.
- Cut-in - Temperature sensed by the controller that turns the compressor on.

**TOOLS REQUIRED:**

- Phillips head screwdriver
- 5/64" or 2 mm Allen wrench
- T-7 Torx wrench

- A.** Unplug or disconnect power to the cabinet.
- B.** Remove the screws that secure the temperature control to the inset box, lower right, rear of cabinet.
- C.** Pull out gently from cabinet.

**NOTE**

**Mechanical temperature controllers are affected when functioning at high altitude. The Cut-in and cut-out temperatures will be colder than when the controller functions closer to sea level.**

- D.** For high elevation installations, it may be necessary to "warm-up" the set points. To make the adjustment, insert the appropriate tool in each adjustment screw and turn 1/4 of a revolution clockwise (to the right). This procedure will adjust both the cut-in and cut-out about 2°F warmer.
- E.** Make sure to reconnect the wire to proper spade terminal when reinstalling.

**DANFOSS TEMPERATURE CONTROL**

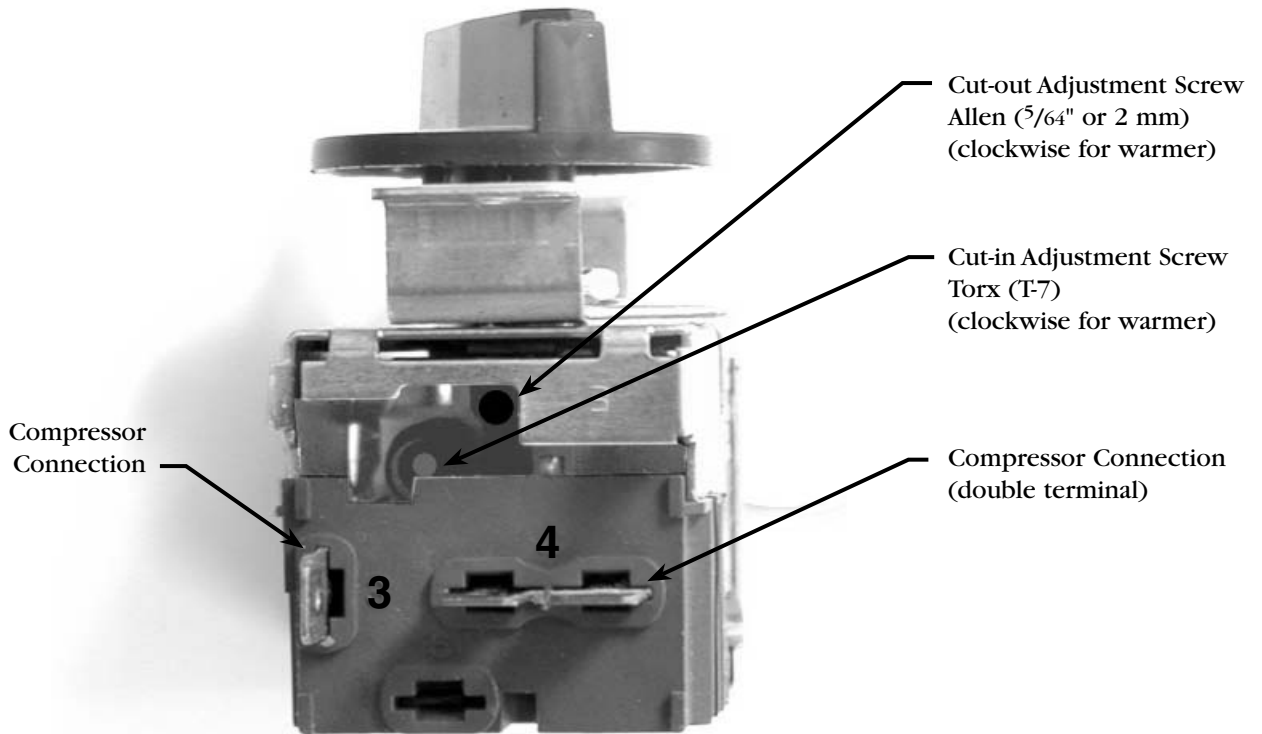

MAINTENANCE, CARE & CLEANING

**CLEANING THE CONDENSER COIL**

When using electrical appliances, basic safety precautions should be followed, including the following

**CONDENSER CLEANING:**

**TOOLS REQUIRED:**

- Phillips screwdriver
- Stiff bristle brush
- Adjustable wrench
- Vacuum

- A.** Disconnect power to unit.
- B.** Take off rear lower grill assembly by removing two (2) bottom screws.  
If necessary, loosen screws holding the top pivot pins. Swing grill up and remove frame hooks from pivot pins at top of louver.
- C.** Remove bolts anchoring compressor assembly to frame rails and carefully slide out (tube connections are flexible).
- D.** Clean off accumulated dirt from condensing coil with a stiff bristle brush.
- E.** After brushing condenser coil vacuum dirt from coil and interior floor.
- F.** Carefully slide compressor assembly back into position and replace bolts.
- G.** Connect unit to power and check to see if condenser is running.
- H.** Reinstall louver assembly onto unit, tighten all screws.

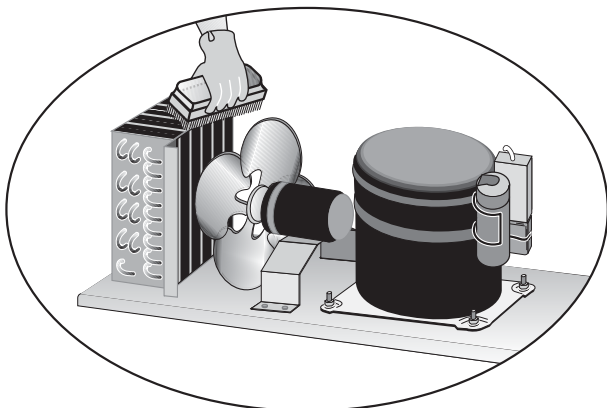
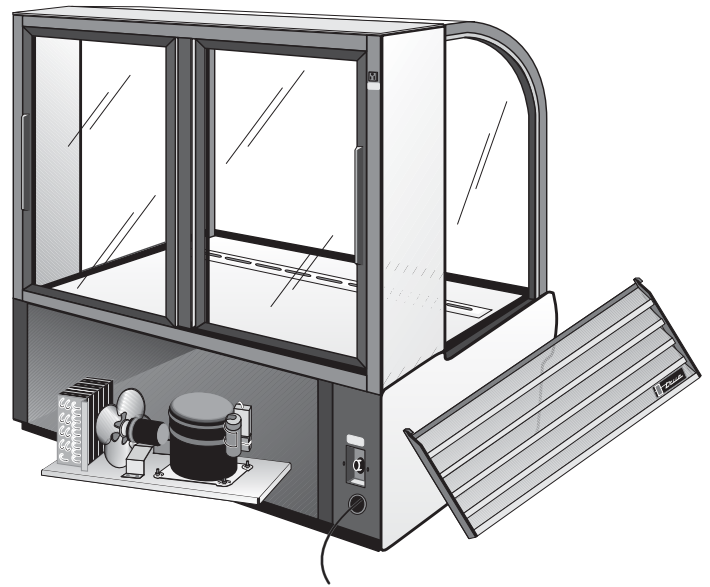

**STEP D**

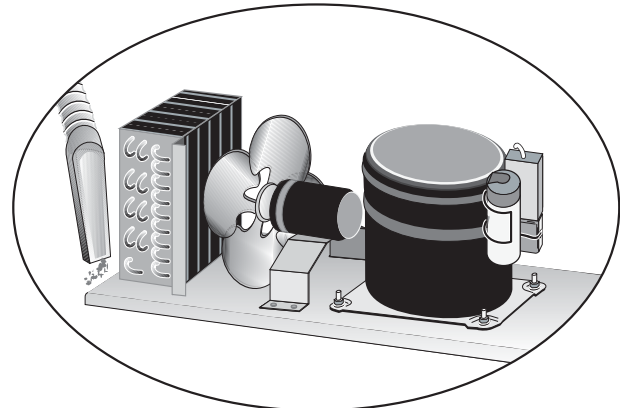

**STEP E**

# **IMPORTANT WARRANTY INFORMATION**

**Condensers accumulate dirt and require cleaning every 30 days. Dirty condensers result in compressor failure, product loss, and lost sales... which are not covered by warranty.**

**If you keep the Condenser clean you will minimize your service expense and lower your electrical costs. The Condenser requires scheduled cleaning every thirty days or as needed.**

**Air is pulled through the Condenser continuously, along with dust, lint, grease, etc.**

**A dirty Condenser can result in NON-WARRANTED part & Compressor Failures, Product Loss, and Lost Sales.**

**Proper cleaning involves removing dust from the Condenser. By using a soft brush, or vacuuming the Condenser with a shop vac, or using CO2, nitrogen, or pressurized air.**

**If you cannot remove the dirt adequately, please call your refrigeration service company.**

**The Condenser looks like a group of vertical fins. You need to be able to see through the condenser for the unit to function at maximum capacity.**

**THE CLEANING OF THE CONDENSER IS NOT COVERED BY THE WARRANTY!**

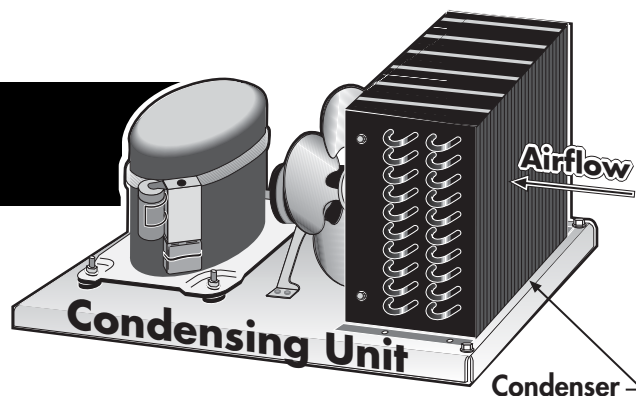

## **HOW TO CLEAN THE CONDENSER:**

- 1. Disconnect the electrical power to the unit.**
- 2. Remove the louvered grill.**
- 3. Vacuum or brush the dirt, lint, or debris from the finned condenser coil.**
- 4. If you have a significant dirt build up you can blow out the condenser with compressed air. (CAUTION MUST BE USED to avoid eye injury. Eye protection is recommended.)**
- 5. When finished be sure to replace the louvered grill. The grill protects the condenser.**
- 6. Reconnect the electrical power to the unit.**

**If you have any questions, please call True Manufacturing at 636-240-2400 or 800-325-6152 and ask for the Service Department.**

**Service Department Availability Monday-Friday 7:30 a.m. to 5:30 p.m. and Saturday 7:45 a.m. to 11:45 a.m. CST.**

## MAINTENANCE, CARE &amp; CLEANING

**STAINLESS STEEL EQUIPMENT CARE AND CLEANING**

**CAUTION:** Do not use any steel wool, abrasive or chlorine based products to clean stainless steel surfaces.

**• Stainless Steel Opponents**

There are three basic things which can break down your stainless steel's passivity layer and allow corrosion to rear its ugly head.

1. Scratches from wire brushes, scrapers, and steel pads are just a few examples of items that can be abrasive to stainless steel's surface.
2. Deposits left on your stainless steel can leave spots. You may have hard or soft water depending on what part of the country you live in. Hard water can leave spots. Hard water that is heated can leave deposits if left to sit too long. These deposits can cause the passive layer to break down and rust your stainless steel. All deposits left from food prep or service should be removed as soon as possible.
3. Chlorides are present in table salt, food, and water. Household and industrial cleaners are the worst type of chlorides to use.

**8 steps that can help prevent rust on stainless steel:****1. Using the correct cleaning tools**

Use non-abrasive tools when cleaning your stainless steel products. The stainless steel's passive layer will not be harmed by soft cloths and plastic scouring pads. Step 2 tells you how to find the polishing marks.

**2. Cleaning along the polish lines**

Polishing lines or "grain" are visible on some stainless steels. Always scrub parallel to visible lines on some stainless steels. Use a plastic scouring pad or soft cloth when you cannot see the grain.

**3. Use alkaline, alkaline chlorinated or non-chloride containing cleaners**

While many traditional cleaners are loaded with chlorides, the industry is providing an ever increasing choice of non-chloride cleaners. If you are not sure of your cleaner's chloride content contact your cleaner supplier. If they tell you that your present cleaner contains chlorides, ask if they have an alternative. Avoid cleaners containing quaternary salts as they can attack stainless steel, causing pitting and rusting.

**4. Water Treatment**

To reduce deposits, soften the hard water when possible. Installation of certain filters can remove corrosive and distasteful elements. Salts in a properly maintained water softener can be to your advantage. Contact a treatment specialist if you are not sure of the proper water treatment.

**5. Maintaining the cleanliness of your food equipment**

Use cleaners at recommended strength (alkaline, alkaline chlorinated or non-chloride). Avoid build-up of hard stains by cleaning frequently. When boiling water with your stainless steel equipment, the single most likely cause of damage is chlorides in the water. Heating any cleaners containing chlorides will have the same damaging effects.

**6. Rinse**

When using chlorinated cleaners you must rinse and wipe dry immediately. It is better to wipe standing cleaning agents and water as soon as possible. Allow the stainless steel equipment to air dry. Oxygen helps maintain the passivity film on stainless steel.

**7. Hydrochloric acid (muriatic acid) should never be used on stainless steel****8. Regularly restore/passivate stainless steel**

MAINTENANCE, CARE & CLEANING

**STAINLESS STEEL EQUIPMENT CARE AND CLEANING**

**Recommended cleaners for certain situations / environments of stainless steel**

- A) Soap, ammonia and detergent medallion applied with a cloth or sponge can be used for routine cleaning.
- B) Arcal 20, Lac-O-Nu Ecoshine applied provides barrier film for fingerprints and smears.
- C) Cameo, Talc, Zud First Impression is applied by rubbing in the direction of the polished lines for stubborn stains and discoloring.
- D) Easy-off and De-Grease It oven aid are excellent for removals on all finishes for grease-fatty acids, blood and burnt-on foods.
- E) Any good commercial detergent can be applied with a sponge or cloth to remove grease and oil.
- F) Benefit, Super Sheen, Sheila Shine are good for restoration / passivation.

**NOTE:**

***The use of stainless steel cleaners or other such solvents is not recommended on plastic parts. Warm soap and water will suffice.***

**WARRANTY INFORMATION (U.S.A. and Canada ONLY!)**

**ONE YEAR PARTS & LABOR WARRANTY**

TRUE warrants to the original purchaser of every new TRUE refrigerated unit, the cabinet and all parts thereof, to be free from defects in material or workmanship, under normal and proper use and maintenance service as specified by TRUE and upon proper installation and start-up in accordance with the instruction packet supplied with each TRUE unit. TRUE's obligation under this warranty is limited to a period of one (1) year from the date of original installation or 15 months after shipment date from TRUE, whichever occurs first.

Any part covered under this warranty that are determined by TRUE to have been defective within one (1) year of original installation or fifteen (15) months after shipment date from manufacturer, whichever occurs first, is limited to the repair or replacement, including labor charges, of defective parts or assemblies. The labor warranty shall include standard straight time labor charges only and reasonable travel time, as determined by TRUE.

**ADDITIONAL FOUR YEAR COMPRESSOR WARRANTY**

In addition to the one (1) year warranty stated above, TRUE warrants its hermetically and semi-hermetically sealed compressor to be free from defects in both material and workmanship under normal and proper use and maintenance service for a period of four (4) additional years from the date of original installation but not to exceed five (5) years and three (3) months after shipment from the manufacturer.

Compressors determined by TRUE to have been defective within this extended time period will, at TRUE's option, be either repaired or replaced with a compressor or compressor parts of similar design and capacity.

The four (4) year extended compressor warranty applies only to hermetically and semi-hermetically sealed parts of the compressor and does not apply to any other parts or components, including, but not limited to, cabinet, paint finish, temperature control, refrigerant, metering device, driers, motor starting equipment, fan assembly or any other electrical component, etcetera.

**404A/134A COMPRESSOR WARRANTY**

The four year compressor warranty detailed above will be voided if the following procedure is not carefully adhered to:

1. This system contains R404A or R134A refrigerant and polyol ester lubricant. The polyol ester lubricant has rapid moisture absorbing qualities. If long exposure to the ambient conditions occur, the lubricant must be removed and replaced with new. For oil amounts and specifications please call True technical service department (800-325-6152). Failure to comply with recommended lubricant specification will void the compressor warranty.
2. Drier replacement is very important and must be changed when a system is opened for servicing. A drier using XH-7 desiccant or an exact replacement solid core drier must be used. The new drier must also be the same capacity as the drier being replaced.
3. Micron level vacuums must be achieved to insure low moisture levels in the system. 500 microns or lower must be obtained.

**WARRANTY CLAIMS**

All claims for labor or parts must be made directly through TRUE. All claims should include: model number of the unit, the serial number of the cabinet, proof of purchase, date of installation, and all pertinent information supporting the existence of the alleged defect.

In case of warranty compressor, the compressor model tag must be returned to TRUE along with above listed information.

Any action or breach of these warranty provisions must be commenced within one (1) year after that cause of action has occurred.

**WHAT IS NOT COVERED BY THIS WARRANTY**

TRUE's sole obligation under this warranty is limited to either repair or replacement of parts, subject to the additional limitations below. This warranty neither assumes nor authorizes any person to assume obligations other than those expressly covered by this warranty.

**NO CONSEQUENTIAL DAMAGES.** TRUE IS NOT RESPONSIBLE FOR ECONOMIC LOSS; PROFIT LOSS; OR SPECIAL, INDIRECT, OR CONSEQUENTIAL DAMAGES, INCLUDING WITHOUT LIMITATION, LOSSES OR DAMAGES ARISING FROM FOOD OR PRODUCT SPOILAGE CLAIMS WHETHER OR NOT ON ACCOUNT OF REFRIGERATION FAILURE.

**WARRANTY IS NOT TRANSFERABLE.** This warranty is not assignable and applies only in favor of the original purchaser/user to whom delivered. ANY SUCH ASSIGNMENT OR TRANSFER SHALL VOID THE WARRANTIES HEREIN MADE AND SHALL VOID ALL WARRANTIES, EXPRESS OR IMPLIED, INCLUDING ANY WARRANTY OF MERCHANTABILITY OR FITNESS FOR A PARTICULAR PURPOSE.

**IMPROPER USAGE.** TRUE ASSUMES NO LIABILITY FOR PARTS OR LABOR COVERAGE FOR COMPONENT FAILURE OR OTHER DAMAGES RESULTING FROM IMPROPER USAGE OR INSTALLATION OR FAILURE TO CLEAN AND/OR MAINTAIN PRODUCT AS SET FORTH IN THE WARRANTY PACKET PROVIDED WITH THE UNIT.

**ALTERATION, NEGLIGENCE, ABUSE, MISUSE, ACCIDENT, DAMAGE DURING TRANSIT OR INSTALLATION, FIRE, FLOOD, ACTS OF GOD.** TRUE is not responsible for the repair or replacement of any parts that TRUE determines have been subjected after the date of manufacture to alteration, neglect, abuse, misuse, accident, damage during transit or installation, fire, flood, or act of God.

**IMPROPER ELECTRICAL CONNECTIONS.** TRUE IS NOT RESPONSIBLE FOR THE REPAIR OR REPLACEMENT OF FAILED OR DAMAGED COMPONENTS RESULTING FROM ELECTRICAL POWER FAILURE, THE USE OF EXTENSION CORDS, LOW VOLTAGE, OR VOLTAGE DROPS TO THE UNIT.

**NO IMPLIED WARRANTY OF MERCHANTABILITY OR FITNESS FOR A PARTICULAR PURPOSE:** THERE ARE NO OTHER WARRANTIES, EXPRESSED, IMPLIED OR STATUTORY, EXCEPT THE ONE (1) YEAR PARTS & LABOR WARRANTY AND THE ADDITIONAL FOUR (4) YEAR COMPRESSOR WARRANTY AS DESCRIBED ABOVE. THESE WARRANTIES ARE EXCLUSIVE AND IN LIEU OF ALL OTHER WARRANTIES, INCLUDING IMPLIED WARRANTY AND MERCHANTABILITY OR FITNESS FOR A PARTICULAR PURPOSE. THERE ARE NO WARRANTIES WHICH EXTEND BEYOND THE DESCRIPTION ON THE FACE HEREOF.

**OUTSIDE U.S.:** This warranty does not apply to, and TRUE is not responsible for, any warranty claims made on products sold or used outside the United States.

**REMOTE CONDENSERS:** True warrants the original purchaser of the remote cabinet one year parts and labor coverage for all cabinet parts thereof to be free from defects in material or workmanship, under normal and proper use and maintenance service, as specified by True. This warranty is limited to the cabinet only. True assumes no liability for remote condensing units.