

**TRICITY BENDIX**

*INSTRUCTION BOOKLET*

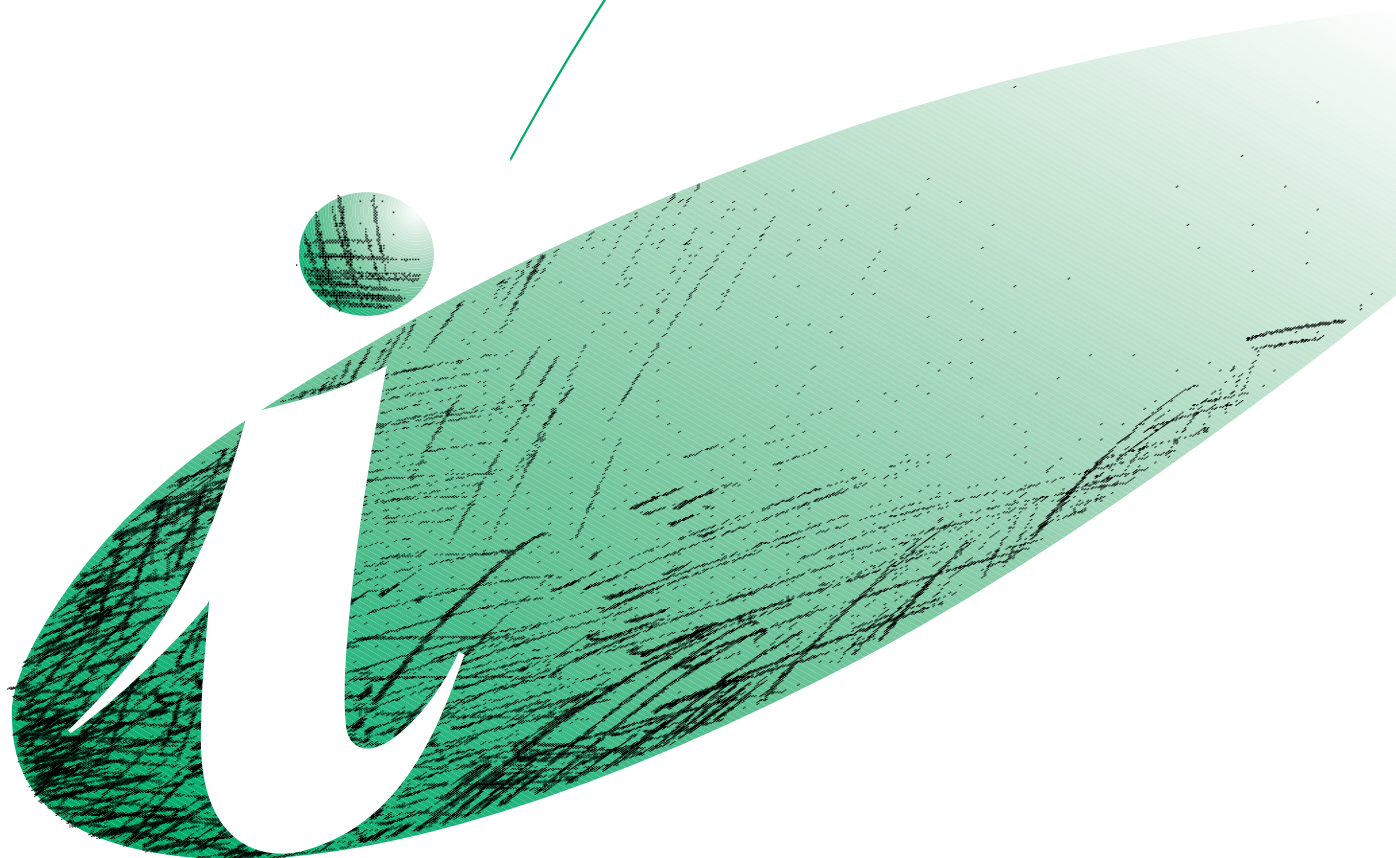

**ELECTRIC COOKER**

**CSIE 223W**

Please read this instruction booklet before using the appliance

# Important Safety Information



**You MUST read these warnings carefully before installing or using the appliance. If you need assistance, contact our Customer Care Department on 08705 950950**

## **Installation**

- This cooker must be installed by qualified personnel, according to the manufacturer's instructions and to the relevant British Standards.
- This cooker is heavy. Take care when moving it.
- Remove all packaging before using the cooker.
- Ensure that the electrical supply complies with the type stated on the rating plate.
- Do not attempt to modify the cooker in any way.
- Do not store flammable materials in the storage drawer.
- Never use plastic dishes in the oven or on the hob hotplates. Never line any part of the oven with aluminium foil.
- Always ensure that the oven vent which is located at the centre back of the hob is left unobstructed to ensure ventilation of the oven cavity.

## **Child Safety**

- This cooker is designed to be operated by adults. Do not allow children to play near or with the cooker.
- The cooker gets hot when it is in use. Children should be kept away until it has cooled.
- Children can also injure themselves by pulling pans or pots off the cooker.

## **During Use**

- This cooker is intended for domestic cooking only. It is not designed for commercial or industrial purposes.
- Do not use this cooker if it is in contact with water. Do not operate the cooker with wet hands.
- Ensure the control knobs are in the 'OFF' position when not in use.
- When using other electrical appliances, ensure the cable does not come into contact with the hot surfaces of the cooker.
- Unstable or misshapen pans should not be used on the hob hotplates as unstable pans can cause an accident by tipping or spillage.
- Never leave the cooker unattended when cooking with oil and fats.
- This cooker should be kept clean at all times. A build-up of fats or foodstuffs could result in a fire.

## **Service**

- This cooker should only be repaired or serviced by an authorised Service Engineer and only genuine approved spare parts should be used.

## **Environmental Information**

- After installation, please dispose of the packaging with due regard to safety and the environment.
- When disposing of an old appliance, make it unusable, by cutting off the cable.

**Keep this instruction book for future reference and ensure it is passed on to any new owner.**

# Contents

## For the User

<b>Important Safety Information</b> .....	<b>2</b>
<b>Description of the Cooker</b> .....	<b>4</b>
<b>Control Panel</b> .....	<b>5</b>
<b>The Oven Cavity</b> .....	<b>5</b>
<b>Accessories</b> .....	<b>5</b>
<b>Operation</b> .....	<b>6</b>
<b>Electric Hotplates</b> .....	<b>6</b>
<b>Electric Oven</b> .....	<b>8</b>
<b>Before the First Use of the Oven</b> .....	<b>8</b>
<b>Using the Oven</b> .....	<b>9</b>
<b>Using the Conventional Oven</b> .....	<b>9</b>
<b>Grilling</b> .....	<b>12</b>
<b>Maintenance and Cleaning</b> .....	<b>13</b>
<b>Cleaning the Oven</b> .....	<b>14</b>
<b>Something Not Working</b> .....	<b>16</b>
<b>Service and Spare Parts</b> .....	<b>17</b>
<b>Guarantee Conditions</b> .....	<b>17</b>

## For the Installer

<b>Instructions for the Installer</b> .....	<b>20</b>
<b>Important Safety Requirements</b> .....	<b>20</b>
<b>Electrical connections</b> .....	<b>21</b>

## Guide to Use the instructions

The following symbols will be found in the text to guide you throughout the Instructions:



Safety Instructions



Step by step instructions for an operation



Hints and Tips



This appliance is manufactured according to the following EEC directives:

73/23 EEC - 90/683 EEC - 93/68 EEC - 89/336 EEC current edition.

### Oven Door Protection Device

All our appliances comply with the European safety standards. Nevertheless, in order to ensure the highest safety level, and avoid small children to be exposed to the heat when the appliance is operated, it is possible to fit a special protection device to the oven door. This device can be purchased in our Service Force Centres, specifying the relevant code (35791) and the Product No. shown on the rating plate.

# Description of the Cooker

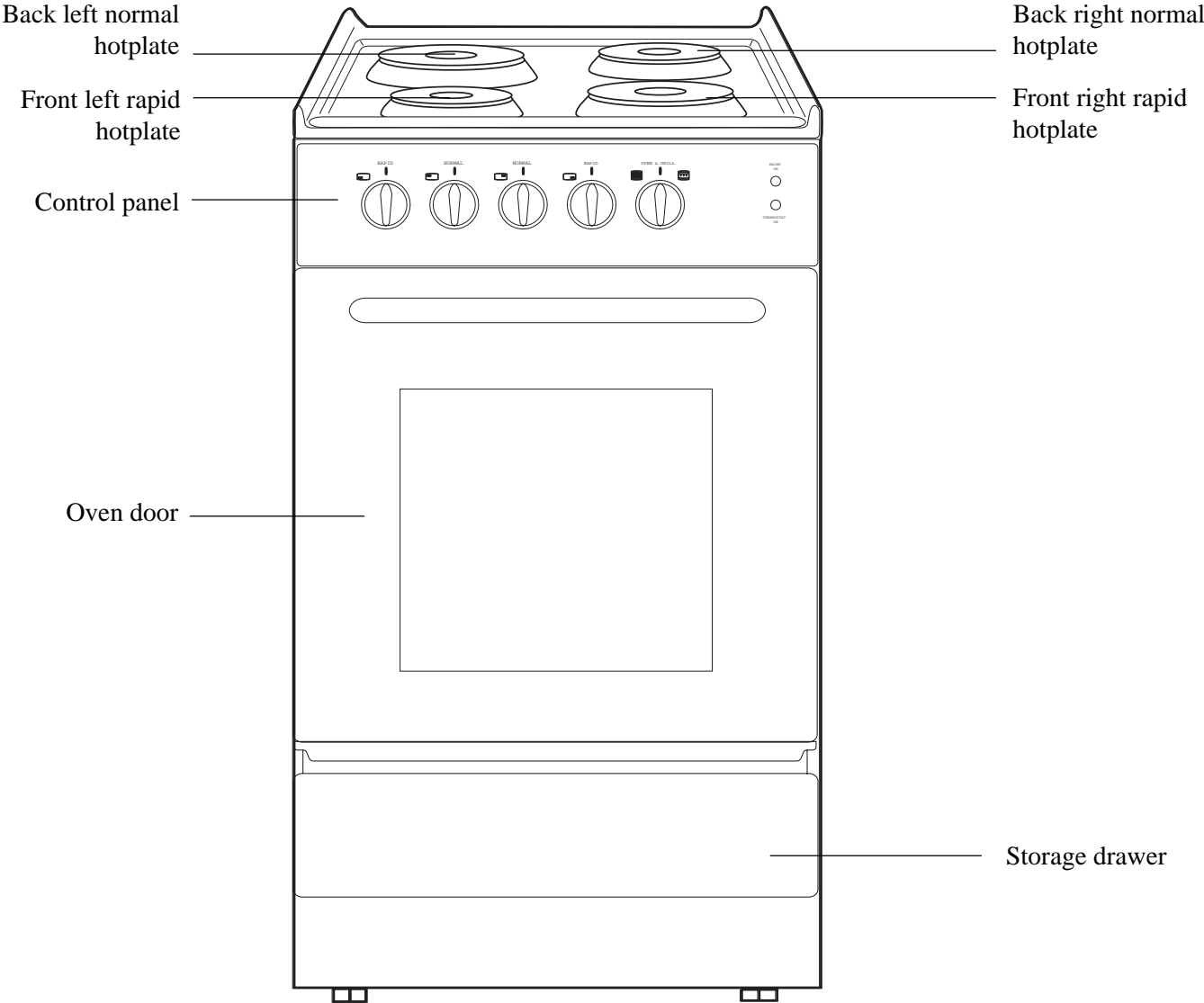

# Control Panel

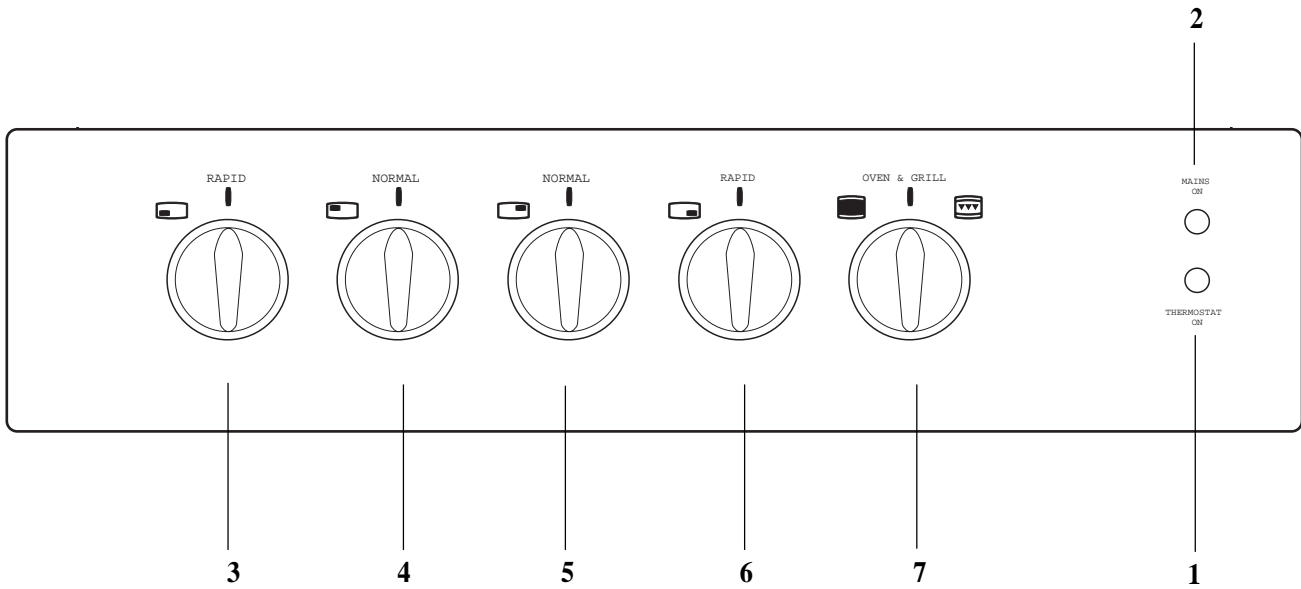

1. Oven Thermostat Pilot Light
2. Cooker Operation Pilot Light
3. Front left hotplate control knob
4. Back left hotplate control knob
5. Back right hotplate control knob
6. Front right hotplate control knob
7. Oven function control knob

## The Oven Cavity

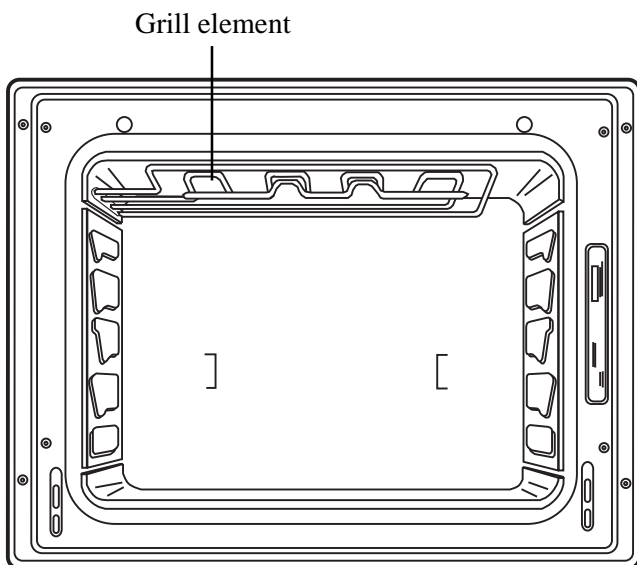

## Accessories

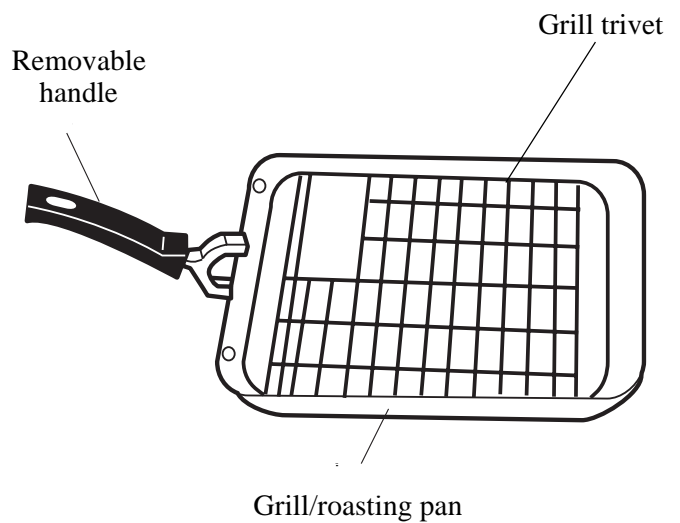

# Operation

## Electric Hotplates

To switch on a hotplate, turn the relevant control knob to the required heat setting.

The control knob is numbered 0 - 6

0 - OFF

1 - Minimum

6 - Maximum.

The hob has two types of hotplates:

### Normal Hotplates (Back right and left)

We recommend the plates are switched to maximum (6) for a short while to boost the plate, and then adjusted to the required setting.

### Rapid Hotplates (Front right and left)

The rapid hotplates indicated by a red spot, will heat up more quickly than a normal plate.

**i** Over a period of time the red spot may disappear, this will not affect the performance of the hotplate.

It is important to note that the plate may smoke a little and produce a slightly unpleasant odour when used for the first time. This is quite normal and will disappear after a few minutes.

Suggestions for the correct setting of the plates are given in the following table.

OFF	0	
Very Gentle	1	To keep food warm To melt butter and chocolate
Gentle	2	To prepare cream-sauces, stews and milk puddings or to fry eggs
Slow	3	Dried vegetables, frozen food, fruit, boiling water or milk
Medium	4	Boiled potatoes, fresh vegetables, pâtés, soups, broths, pancakes or fish
High	5	Larger stews, meat roll, fish, omelettes, steaks
Fast	6	Steaks, escalopes and frying.

## Hints and Tips

Saucepans for use on solid plates should have several characteristics:

- They should be fairly heavy duty
- They should fit the heat area exactly, or be slightly larger for efficient use, NEVER smaller.
- They should have a flat base to ensure good contact with the plate.

This is particularly important when using pans for high temperature frying or pressure cooking.

As soon as liquid starts boiling, turn down the plate control knob so that it will barely keep the liquid simmering.

You can switch off the plate a short while before you finish cooking, and the final stage will be completed on the accumulated heat. Similarly, stews etc. cooked in well covered saucepans cook at lower temperature which is more economical.

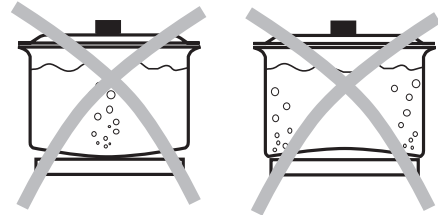
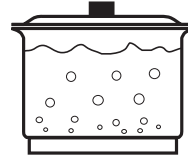

*Ensure pans are large enough to avoid liquids being split onto the plates.*

*Never leave the plates on without a pan on them or with an empty pan on them.*

*Take care never to lean or reach over a hot electric plate. Always point pan handles inward or over the work surface next to the hob to avoid accidentally knocking over a pan as you pass by.*

*Take care when frying food in hot oil or fat, as the overheated splashes could easily ignite.*

*If the control knobs become difficult to turn, please contact your local Tricity Bendix Service Centre.*

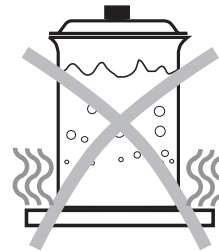
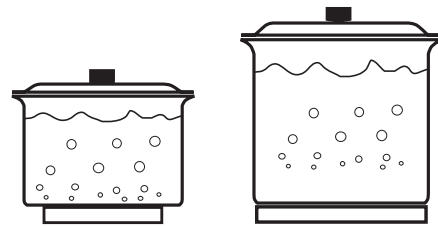

# Electric Oven

## Oven Function Control Knob

**0**

Oven switched off



Heating elements switched on

**0-max**

Range of temperature regulation for conventional cooking



Bottom heating element - The heat comes from the bottom of the oven only



Top heating element - The heat comes from the top of the oven only



Grill - The heat comes only from the top element

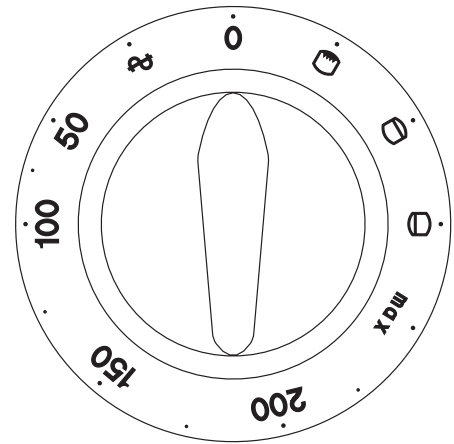

# Before the First Use of the Oven



*Remove **all packaging**, both inside and outside the oven, before using the oven.*

Before first use, the oven should be heated without food. During this time, an unpleasant odour may be emitted. This is quite normal.



1. Set the oven function control knob to MAX.
2. Open a window for ventilation.
3. Allow the oven to run empty for approximately 45 minutes.

This procedure should be repeated with the grill  function for approximately 5-10 minutes.



# Using the Oven



- *Always cook with the oven door closed.*
- *Stand clear when opening the drop down oven door. Do not allow it to fall open - support the door using the door handle, until it is fully open.*



- The oven has four shelf levels, and is supplied with two shelves.  
The shelf positions are counted from the bottom of the oven as shown in the diagram.  
It is important that these shelves are correctly positioned as shown in the diagram.
- Do not place cookware directly on the oven base.

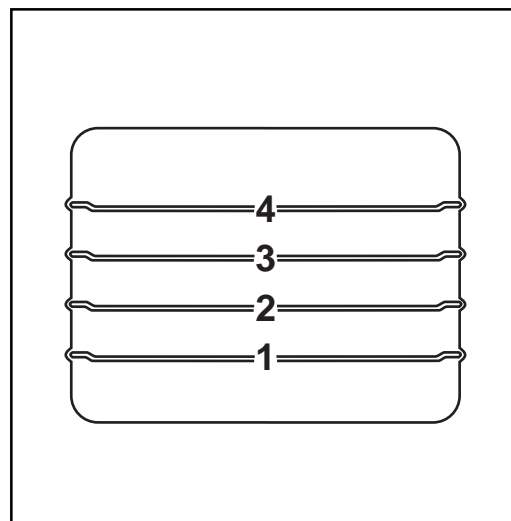

## Hints and Tips

### Condensation and steam

When food is heated it produces steam in the same way as a boiling kettle. The oven vents allow some of this steam to escape. However, **always stand back from the oven when opening the oven door** to allow any build up of steam or heat to release. If the steam comes into contact with a cool surface on the outside of the oven, e.g. a trim, it will condense and produce water droplets. This is quite normal and is not a fault with the oven.

To prevent discoloration, regularly wipe away condensation and also soilage from surfaces.

### Cookware

- Use any oven proof cookware which will withstand temperatures of 250°C.
- Baking trays, oven dishes, etc. should not be placed directly against the grid covering the fan at the back of the oven, or placed on the oven base.
- Do not use baking trays larger than 30 cm x 35 cm (12 in x 14 in) as they will restrict the circulation of heat and may affect performance.

### The effects of dishes on cooking results

Dishes and tins vary in their thickness, conductivity, colour, etc. which affects the way they transmit heat to the food inside them.

- A** Aluminium, earthenware, oven glassware and bright shiny utensils reduce cooking and underneath browning.
- B** Enamelled cast iron, anodized aluminium, aluminium with non-stick interior and coloured exterior and dark, heavy utensils increase cooking and underneath browning.

### Storage Drawer

The storage drawer is located underneath the oven cavity.



During cooking the storage drawer may become hot if the oven is on high for a long period of time, therefore flammable materials such as oven gloves, tea towels, plastic aprons etc. should not be stored in the drawer.

Oven accessories such as baking sheets, will also become hot, therefore care should be taken when removing these items from the drawer whilst the oven is in use or still hot.

# Using the Conventional Oven

## How to Use the Conventional Oven

Turn the oven function control knob to the required temperature.

### THINGS TO NOTE

- The thermostat control light will remain on until the correct temperature is reached. It will then cycle on and off to show that temperature is being maintained.

### Top oven element only

This function is suitable for finishing cooked dishes, eg; lasagne, shepherds pie, cauliflower cheese etc.

### Bottom oven element only

This function is particularly useful when blind-baking pastry or cooking pizza. It may also be used to finish off quiches or flans to ensure the base pastry is cooked through.

## Hints and Tips

The middle shelf position allows for the best heat distribution. To increase base browning simply lower the shelf position. To increase top browning, raise the shelf position.

The material and finish of the baking trays and dishes used will affect base browning. Enamelware, dark, heavy or non-stick utensils increase base browning, while oven glassware, shiny aluminium or polished steel trays reflect the heat away and give less base browning.

Always place dishes centrally on the shelf to ensure even browning.

Stand dishes on suitably sized baking trays to prevent spillage onto the base of the oven and make cleaning easier.

**Do not** place dishes, tins or baking trays directly on the oven base as it becomes very hot and damage will occur.

For faster preheating use the fan oven function to preheat the oven until the oven indicator neon goes out, then switch the selector to the conventional oven setting.

Single level cooking gives best results. If you require more than one level cooking use the fan oven function.

# Cooking Chart

Food	Temperature (°C)	Runner Positions	Cooking Time (mins)
Biscuits - small cakes	160-180	2	25-30
Bread, buns, yeast, doughs	200-220	2	35-45
Casseroles	150-170	1-2	90-180
Queen Victoria sponge	170-190	1-2	20-30
Cakes - madeira, rich fruit	150-170	2	90-150
Choux pastry, eclairs	200-220	2	30-35
Fish	200-220	2	20-40
Fruit pies, plate tarts, crumbles	180-200	2	50-65
Meringues	90-100	2	90-150
Milk puddings	140-160	2	90-150
Pate, terrine (in baine-marie)	160-180	1-2	60-90
Pizzas	200-230	1-2	25-30
Puff pastry, sausage rolls, vol-au-vents	200-220	2	15-25
Quiches, flans	170-200	1-2	50-60
Scones	200-220	2	8-15
Souffle	200-220	2	35-45
Stuffed vegetables	200-220	2	35-45
Roast meat & poultry	180-200	2	see meat + poultry roasting chart
Yorkshire pudding	200-220	2	40-50
Keep food warm, heat dishes	90-100	2	

# Meat and Poultry Roasting Chart

Meat	Cooking Time
Beef	20-35 mins per 1/2kg (lb) + <b>20-35 mins</b>
Beef, boned	25-35 mins per 1/2kg (lb) + <b>25-35 mins</b>
Mutton and Lamb	25-35 mins per 1/2kg (lb) + <b>25-35 mins</b>
Pork and Veal	30-40 mins per 1/2kg (lb) + <b>30-40 mins</b>
Ham	30-40 mins per 1/2kg (lb) + <b>30-40 mins</b>
Chicken	15-20 mins per 1/2kg (lb) + <b>20 mins</b>
Turkey and Goose	15-20 mins per 1/2kg (lb) up to 3.5kg (7.5lb) + <b>15 mins</b>
Duck	25-35 mins per 1/2kg (lb) + <b>20 mins</b>

When roasting, ensure the meat is cooked thoroughly, use a meat thermometer if preferred to check the centre temperature has reached the required temperature (see table below).

MEAT	TEMPERATURES
Beef	Rare - 60°C Medium - 70°C Well Done - 80°C
Pork	Well Done - 80°C
Lamb	Medium - 70°C Well Done - 80°C

# Grilling



*Grilling must be carried out with the oven door closed. The grill pan handles must be removed from the pan.*

## How to Use the Grill

1. Turn the oven control function knob to .
2. Adjust the grid and grill pan runner position to allow for different thicknesses of food. Position the food close to the element for faster cooking and further away for more gentle cooking.

Preheat the grill for a few minutes before sealing steaks or toasting. Adjust the shelf as necessary, during cooking.

## Hints and Tips

- Most foods should be placed on the grid in the grill pan to allow maximum circulation of air to lift the food out of the fats and juices. Food such as fish, liver and kidneys may be placed directly on the grill pan, if preferred
- Food should be thoroughly dried before grilling to minimise splashing. Brush lean meats and fish lightly with a little oil or melted butter to keep them moist during cooking
- Accompaniments such as tomatoes and mushrooms may be placed underneath the grid when grilling meats
- When toasting bread, we suggest that the top runner position is used.
- The food should be turned over during cooking, as required.

Food	Grill Time (Min)
Bacon rashers	2-3 each side
Beefburgers	6-10 each side
Chicken joints	10-15 each side
Chops: lamb	7-10 each side
pork	10-15 each side
Fish: whole trout/herring	8-12 each side
fillets plaice/cod	4-6 each side
Kebabs	10-15 each side
Kidneys: lamb/pig	4-6 each side
Liver: lamb/pig	5-10 each side
Sausages	10-15 turn as required
Steaks: rare	3-6 each side
medium	6-8 each side
well	7-10 each side
Browning only	3-5

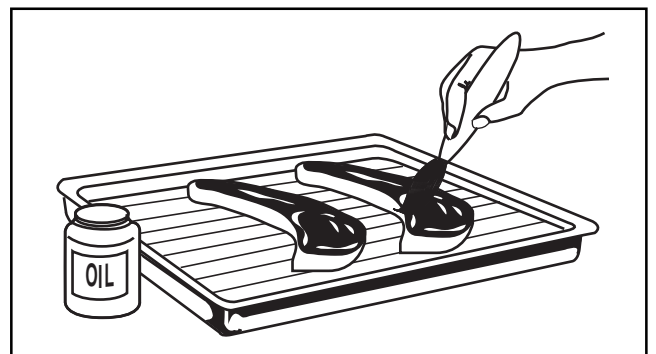

# Maintenance and Cleaning



Before any maintenance or cleaning can be carried out, you must **DISCONNECT** the cooker from the electricity supply.

## The Hob Top

The hob is best cleaned whilst it is still warm, as spillage can be removed more easily than if it is left to cool.

Regularly wipe over the hob top using a soft cloth well wrung out in warm water to which a little washing up liquid has been added. Avoid the use of the following:

- household detergent and bleaches;
- impregnated pads unsuitable for non-stick saucepans;
- steel wool pads;
- bath/sink stain removers.

Should the hob top become heavily soiled, it is recommended that a cleaning product such as Hob Brite or Bar Keepers Friend is used.



## The Hotplates

Spills onto the actual plate should be removed using warm water and a soft brush, nylon or plastic scourer. To keep the plates looking as new, hotplate conditioner can be purchased from most hardware stores, e.g. "4 Hob" by HomeCare Products (follow the manufacturer's instruction for use).

Alternatively, wipe the plates with a drop of olive oil on a kitchen towel to avoid rust. It is important to note that the plate will smoke a little and produce a slightly unpleasant odour when next used.

## Drying

Important: After cleaning, dry the hotplates thoroughly by switching on to a low-medium setting for a few minutes.

## Restoring

To maintain the appearance of your sealed hotplates apply a little salt-free vegetable oil or restorative agent (i.e. "Collo Electrol", or Minky Hotplate Cleaning Cloths) periodically.

*To apply vegetable oil:* first heat the hotplate on a medium setting for 30 seconds then turn off. Pour a very small amount of salt-free oil onto a dry cloth or kitchen paper. Apply a thin coat of oil to the hotplate surface and wipe off any excess. Heat the hotplate on a medium setting for 1 minute.

*To apply restorative agent:* first heat the hotplate on a medium setting for 30 seconds then turn off. Apply a very thin coating of Collo Electrol (using the applicator). Heat the hotplate on a high setting for 2-3 minutes to cure. Some smoke will occur, this is normal and nontoxic. (NB: this product is a restorative agent not a cleanser. It is available from hardware stores).

*Stainless steel parts:* the stainless steel spill rings may become straw coloured with use. Use a proprietary stainless steel cleaner to remove this straw discolouration. This also applies to the area around the hotplates on stainless steel hobs.

# Cleaning the Oven



*Before cleaning always allow the cooling fan to cool the oven down before switching off at the electricity supply.*

*The oven should be kept clean at all times. A build-up of fats or other foodstuffs could result in a fire, especially in the grill pan.*

## Cleaning materials

Before using any cleaning materials on your oven, check that they are suitable and that their use is recommended by the manufacturer.

Cleaners that contain bleach should NOT be used as they may dull the surface finishes. Harsh abrasives should also be avoided.

## External cleaning

Regularly wipe over the control panel, oven door and door seal using a soft cloth well wrung out in warm water to which a little washing up liquid has been added.



*To prevent damaging or weakening the door glass panels avoid the use of the following:*

- Household detergent and bleaches
- Impregnated pads unsuitable for non-stick saucepans
- Brillo/Ajax pads or steel wool pads
- Chemical oven pads or aerosols
- Rust removers
- Bath/Sink stain removers

Clean the outer and inner door glass using warm soapy water. Should the inner door glass become heavily soiled it is recommended that a cleaning product such as Hob Brite, or Bar Keepers Friend is used.



*DO NOT clean the oven door while the glass panels are warm. If this precaution is not observed the glass panel may shatter.*

*If the door glass panel becomes chipped or has deep scratches, the glass will be weakened and must be replaced to prevent the possibility of the panel shattering. Contact your local Service Centre who will be pleased to advise further.*

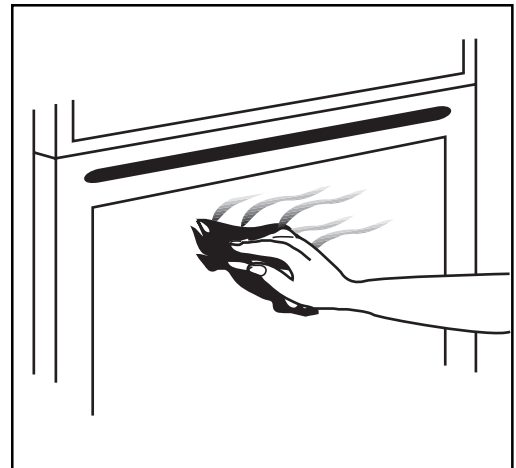

### **Oven Cavity**

The enamelled oven cavity is best cleaned whilst the oven is still warm.

Wipe the oven over with a soft cloth soaked in warm soapy water after each use. From time to time it will be necessary to do a more thorough cleaning, using a proprietary oven cleaner.

### **Oven Shelves**

To clean the oven shelves, soak in warm soapy water and remove stubborn marks with a well wetted soap impregnated pad. Rinse well and dry with a soft cloth.

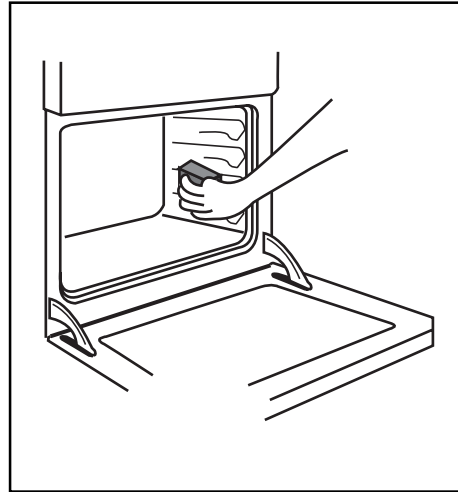

# Something Not Working

If the appliance is not working correctly, please carry out the following checks, before contacting your local Tricity Bendix Service Centre.

**IMPORTANT:** If you call out an engineer to a fault listed below, or to repair a fault caused by incorrect use or installation, a charge will be made even if the appliance is under guarantee.

SYMPTOM	SOLUTION
<ul style="list-style-type: none"> <li>■ The hob hotplate does not heat up.</li> </ul>	<ul style="list-style-type: none"> <li>◆ Check that the unit is plugged in and the electrical supply is switched on</li> <li>◆ Check that the RCCB has not tripped (if fitted)</li> <li>◆ Check the mains fuse has not blown</li> <li>◆ Check the correct control knob has been turned.</li> </ul>
<ul style="list-style-type: none"> <li>■ The plate is not giving satisfactory results</li> </ul>	<ul style="list-style-type: none"> <li>◆ Check the plate is clean and dry</li> <li>◆ Check the cooking pan is the correct size for the plate.</li> <li>◆ Check the cooking pan has a flat bottom</li> <li>◆ Check the setting is correct for the type of cooking.</li> </ul>
<ul style="list-style-type: none"> <li>■ The oven does not come on</li> </ul>	<ul style="list-style-type: none"> <li>◆ Check a cooking function / temperature have been selected.</li> <li>◆ The socket switch or the switch from the mains supply to the cooker are ON.</li> </ul>
<ul style="list-style-type: none"> <li>■ The oven temperature light does not come on</li> </ul>	<ul style="list-style-type: none"> <li>◆ Select a temperature with the oven function control knob.</li> </ul>
<ul style="list-style-type: none"> <li>■ It takes too long to finish the dishes, or they are cooked too fast.</li> </ul>	<ul style="list-style-type: none"> <li>◆ The temperature may need adjusting</li> </ul>
<ul style="list-style-type: none"> <li>■ Steam and condensation settle on the food and the oven cavity.</li> </ul>	<ul style="list-style-type: none"> <li>◆ Refer to the contents of this booklet, especially to the chapter “Using the Oven”.</li> <li>◆ Leave dishes inside the oven no longer than 15-20 minutes after the cooking is completed.</li> </ul>

If after these checks, the appliance still does not work, contact your local Service Force Centre.

When you contact the Service Centre, they will need the following information:

1. Your name, address and post code.
2. Your telephone number
3. Clear and concise details of the fault
4. The model and the serial number (see rating label)
5. Date of purchase



## Service and Spare Parts

If you require spare parts or an engineer contact your local Service Force Centre by telephoning:

**08705 929 929**

Your call will be routed to the Service Centre covering your post code area. The addresses of Tricity Bendix Service Force Centres are detailed on the following pages.

### **CUSTOMER CARE**

For general enquiries concerning your Tricity Bendix appliance and for further information on Tricity Bendix products, contact our Customer Care Department by letter or telephone as follows:

#### **Customer Care Department**

Tricity Bendix  
55-77 High Street  
Slough  
Berkshire SL1 1DZ  
Tel : 08705 950 950

## Guarantee Conditions

### **TRICITY BENDIX STANDARD GUARANTEE CONDITIONS**

We, Tricity Bendix, undertake that if, within 12 months of the date of the purchase, this Tricity Bendix appliance or any part thereof is proved to be defective by any reason only of faulty workmanship or materials, we will, at our option, repair or replace the same **FREE OF ANY CHARGE** for labour, materials or carriage on condition that:

- \* The appliance has been correctly installed and used only on the gas and electricity supply stated on the rating plate.
- \* The appliance has been used for normal domestic purposes only, and in accordance with the manufacturer's instructions.
- \* The appliance has not been serviced, maintained, repaired, taken apart or tampered with by any person not authorised by us.
- \* All service work under this guarantee must be undertaken by a Tricity Bendix Service Force Centre.
- \* Any appliance or defective part replaced shall become the Company's property.
- \* This guarantee is in addition to your statutory and other legal rights.

Home visits are made between **8.30am and 5.30pm** Monday to Friday. Visits may be available outside these hours, in which case a **premium** will be charged.

### **Exclusions**

#### **This guarantee does not cover:**

- \* Damage or calls resulting from transportation, improper use or neglect, the replacement of any light bulbs or removable parts of glass or plastic.
- \* Costs incurred for calls to put right an appliance which is improperly installed or calls to appliance outside the United Kingdom.

- \* Appliances found to be in use within a commercial or similar environment, plus those which are the subject to rental agreements.
- \* Products of Tricity Bendix manufacture which are not marketed by Tricity Bendix.

### **European Guarantee**

If you should move to another country within Europe then your guarantee moves with you to your new home subject to the following qualifications:

- \* The guarantee starts from the date you first purchased your product.
- \* The guarantee is for the same period and to the same extent for labour and parts as exist in the new country of use for this brand or range of products.
- \* This guarantee relates to you and cannot be transferred to another user.
- \* Your new home is within the European Community (EC) or European Free Trade Area.
- \* The product is installed and used in accordance with our instructions and is only used domestically, i.e. a normal household. The electrical supply complies with the specification given in the rating label.
- \* The product is installed taking into account regulations in your new country.

Before you move, please contact your nearest Customer Care centre, listed below, to give them details of your new home. They will then ensure that the local Service Organisation is aware of your move and able to look after you and your appliances.

France	Senlis	+33 (0)3 44 62 22 22
Germany	Nürnberg	+49 (0)911 323 2600
Italy	Pordenone	+39 (0)1678 47053
Sweden	Stockholm	+46 (0)20 78 77 50
UK	Slough	+44 (0)1753 219 898

To contact your local Tricity Bendix Service Force Centre telephone 08705 929 929

### CHANNEL ISLANDS

GUERNSEY Guernsey Electricity  
PO Box 4  
Vale, Guernsey  
Channel Islands

JERSEY Jersey Electricity  
Company  
PO Box 45  
Queens Road  
St Helier  
Jersey  
Channel Islands  
JE4 8NY

### SCOTLAND

ABERDEEN 8 Cornhill Arcade  
(M05) Cornhill Drive  
Aberdeen  
AB2 5UT

AUCHTERMUCHY 33A Burnside  
(M03) Auchtermuchy  
Fife  
KY14 7AJ

BLANTYRE Unit 5  
(M07) Block 2  
Auchenraith Industrial  
Estate  
Rosendale Way  
Blantyre  
G72 0NJ

DUMFRIES 93 Irish Street  
(M01) Dumfries  
Scotland  
DG1 2PQ

DUNOON Briar Hill  
(M 67) 7 Hill Street  
Dunoon  
Argyll  
PA23 7AL

GLASGOW 20 Cunningham Road  
(M04) Clyde Estate  
Rutherglen,  
Glasgow,  
G73 1PP

INVERNESS Unit 3B  
(M06) Smithton Indust. Est.  
Smithton  
Inverness  
IV1 2PD

ISLE OF ARRAN Arran Domestic  
(OWN SALES) Unit 4 The Douglas  
Centre  
Brodick  
Isle of Arran  
KA27 8AJ

ISLE OF BARRA J Zerfah  
(OWN SALES) 244 Bruernish  
Isle of Barra  
Western Islands  
HS9 5QY

ISLE OF BUTE Walker Engineering  
(M66) Glenmhor  
Upper Serpentine Road  
Rothesay  
Isle of Bute  
PA20 9EH

ISLE OF LEWIS ND Macleod  
(M69) 16 James Street  
Stornoway  
Isle of Lewis  
PA872QW

KELSO 2-8 Wood Market  
(M08) Kelso  
Borders TD5 7AX

ORKNEY Corsie Domestic  
(M65) 7 King Street  
Kirkwall  
Orkney KW15 1RE

PERTH Hydro Electrical  
Inveralmond House  
Ruthervenfield Road  
Perth PH1 3AQ

PERTH Graham Begg Unit 4  
(OWN SALES) Airport Ind Estate  
Wick KW1 4QS

SHETLAND Tait Electronic Systems  
Ltd.  
Holmsgarth Road  
Lerwick  
(OWN SALES) Shetland ZE1 0PW

SHETLAND Bolts Shetland Ltd  
26 North Road  
Lerwick  
(OWN SALES) Shetland ZE1 0PE

WHALSAY Leask Electrical  
(OWN SALES) Harlsdale  
Symbister, Whalsay  
Shetland ZE2 9AA

### NORTHERN IRELAND

BELFAST Owenmore House  
(M27) Kilwee Industrial Estate  
Upper Dunmury Lane  
Belfast  
BT17 0HD

### WALES

CARDIFF Guardian Industrial  
(M28) Estate  
Clydesmuir Road  
Tremorfa, Cardiff  
CF2 2QS

CLYWD Unit 6-7 Coed - Parc  
(M14) Abergele Road  
Rhuddlan  
Clwyd  
Wales  
LL18 5UG

OSWESTRY Plas Funnon Warehouse  
(M17) Middleton Road  
Oswestry  
SY11 2PP

HAVERFORDWEST Ark Appliances  
(M75) Cromlech Lodge  
Ambleston  
Haverfordwest  
Pembrokeshire  
SA62 5DS

DYFED West Wales Appliances  
(M77) Service  
Maes Y Coed  
High Mead  
Llanybydder  
Carmarthenshire  
SA40 9UL

### NORTH EAST

GATESHEAD Unit 356a  
(M39) Dukesway Court  
Dukesway  
Team Valley  
Gateshead  
NE11 0BH

GRIMSBY Unit 2  
(M42) Cromwell Road  
Grimsby  
South Humberstone  
DN31 2BN

HULL Unit 1  
(M41) Boulevard Industrial  
Estate  
Hull  
HU3 4AY

LEEDS 64-66 Cross Gates Road  
(M37) Leeds  
LS15 7NN

NEWTON AYCLIFFE Unit 16  
(M45) Gurney Way  
Aycliffe Ind Estate  
Newton Aycliffe  
DL5 6UJ

SHEFFIELD Pennine House  
(M38) Roman Ridge Ind.  
Roman Ridge Road  
Sheffield  
S9 1GB

### NORTH WEST

BIRKENHEAD 1 Kelvin Park  
(M11) Dock Road  
Birkenhead  
L41 1LT

CARLISLE Unit 8  
(M10) South John Street  
Carlisle  
CA2 5AJ

ISLE OF MAN South Quay Ind Estate  
(M64) Douglas  
Isle of Man

LIVERPOOL Unit 1  
(M15) Honeys Green Precinct  
Honeys Green Lane  
Liverpool  
L12 9JH

MANCHESTER Unit 30  
(M09) Oakhill Trading  
Estate  
Devonshire Road  
Worsley  
Manchester  
M28 3PT

PRESTON Unit 250  
(M13) Dawson Place  
Walton Summit  
Bamber Bridge  
Preston  
Lancashire  
PR5 8AL

STOCKPORT Unit 20 Haigh Park  
(M16) Haigh Avenue  
Stockport  
SK4 1QR

To contact your local Tricity Bendix Service Force Centre telephone 08705 929 929

## MIDLANDS

BIRMINGHAM (M18)	66 Birch Road East, Wyrley Road Industrial Estate Witton Birmingham B67DB
BOURNE (M44)	Manning Road Ind Estate Pinfold Road Bourne PE10 9HT
BRIDGNORTH (M72)	1 Underhill Street Bridgnorth Salop WV16 4BB
GLOUCESTER (M23)	101 Rycroft Street Gloucester GL1 4NB
HEREFORD (M31)	Unit 3 Bank Buildings Cattle Market Hereford HE4 9HX
HIGHAM FERRERS (M51)	The Old Barn Westfield Terrace Higham Ferrers NN10 8BB
ILKESTON (M43)	Unit 2 Furnace Road Ilkeston DE7 5EP
LEICESTER (M22)	Unit 7 Oaks Industrial Estate Coventry Road Narborough Leicestershire LE0 5GF
LINCOLN (M40)	Unit 8 Stonefield Park Clifton Street Lincoln LN5 8AA
NEWCASTLE UNDER LYME (M12)	18-21 Croft Road Brampton Industrial Estate Newcastle under Lyme Staffordshire ST5 0TW
NUNEATON (M21)	19 Parmigan Place Townsend Drive Nuneaton CV11 6RX
REDDITCH (M20)	Heming Road Washford Redditch Worcestershire B98 0DH
TAMWORTH (M19)	Unit 3 Sterling Park Claymore Tamworth B77 5DO
WORCESTER (M73)	Unit 1 Northbrook Close Gregorys Mill Ind Estate Worcester WR3 8BP

## LONDON &amp; EAST ANGLIA

BECKENHAM (M79)	11a Gardener Ind Estate Kent House Lane Beckenham Kent BR3 1QZ
CHELMSFORD (M47)	Hanbury Road Widford Ind Estate Chelmsford Essex CM12 3AE
COLINDALE (M53)	Unit 14 Capital Park Capital Way Colindale London NW9 0EQ
ELTHAM (M78)	194 Court Road Mottingham - Eltham London SE9 4EW
ENFIELD (M49)	284 Alma Road Enfield London EN3 7BB
GRAVESEND (M57)	Unit B4, Imperial Business Estate Gravesend Kent DA11 0DL
HARPENDEN (M46)	Unit 4 Riverside Estate Coldharbour Lane Harpenden AL5 4UN
LETCHWORTH (M50)	16-17 Woodside Ind Est. Works Road Letchworth Herts SG6 1LA
LONDON (M76)	2/4 Royal Lane Yiewsley West Drayton Middlesex UB7 8DL
MAIDENHEAD (M60)	Reform Road Maidenhead - Berkshire SL6 8BY
MOLESEY (M61)	10 Island Farm Avenue West Molesey Surrey KT8 2UZ
NEWBURY (M24)	PO BOX 5672 Newbury Berkshire RG14 5GF
IPSWICH (M48)	Unit 2B Elton Park Business Centre Hadleigh Road Ipswich IP2 0DD
NORWICH (M52)	2b Trafalgar Street Norwich NR1 3HN
SUNBURY (M63)	Unit 1a The Summit Hanworth Road Hanworth Ind Estate Sunbury on Thames TW16 5D

## SOUTH EAST

ASHFORD (M58)	Unit 2 Bridge Road Business Estate Bridge Road Ashford Kent TN2 1BB
FLEET (M59)	Unit 1 Redfields Industrial Estate Church Crookham Fleet Hampshire GU13 0RD
HAYWARDS HEATH (M55)	21-25 Bridge Road Haywards Heath Sussex RH16 1UA

## SOUTH WEST

BARNSTAPLE (M30)	P.O. Box 12 Barnstaple North Devon EX31 2YB
BOURNEMOUTH (M26)	63-65 Curzon Road Bournemouth Dorset BH1 4PW
BRIDGEWATER (M35)	6 Hamp Industrial Estate Bridgewater Somerset
BRISTOL (M25)	11 Eldon Way Eldonwall Trading Bristol Avon BS4 3QQ
EMSWORTH (M33)	266 Main Road Southbourne Emsworth PO10 8JL
ISLE OF WIGHT (M34)	Unit 8 Enterprise Court Ryde Business Park Ryde Isle of Wight PO33 1DB
NEWTON ABBOT (M29)	Unit 2 Zealley Industrial Estate Kingsteignton Newton Abbot S. Devon TQ12 3TD
PLYMOUTH (M32)	16 Faraday Mill Cattedown Plymouth PL4 0ST
REDRUTH (M36)	Unit 7D Pool Industrial Estate Wilson Way, Redruth, Cornwall TR15 3QW

# Instructions for the Installer

## Technical Data

**Model Number:** CSIE 223 W

### Dimensions

Height	900 mm
Depth	600 mm
Width	495 mm
Oven Capacity	1.7 Cu. ft

### Hob

Front left heating plate (rapid)	1,565 W/Ø145 mm
Back left heating plate (normal)	1,565 W/Ø180 mm
Back right heating plate (normal)	1,043 W/Ø145 mm
Front right heating plate (rapid)	2,086 W/Ø180 mm
Total rating	6,259 W

### Oven

Top heating element	1,043 W
Bottom heating element	1,215 W
Grill Element	1,877 W
Total rating	2,258 W
Supply voltage (50 Hz)	230-240 V

Total cooker rating 8,517 W

## Important Safety Requirements

This cooker must be installed in accordance with the IEE Wiring Regulations (Current Edition).

Detailed recommendations are contained in the following British Standards Codes Of Practice: B.S. 6172/ B.S. 5440, Par. 2 and B.S. 6891 Current Editions.

### Location

This cooker has been registered as a "Class X" appliance according to Fire Risk Regulations. Any adjacent cabinets or walls must not exceed the cooker's height.

The cooker may be located in a kitchen, a kitchen/diner or bed sitting room, but not in a bathroom or shower room.

The minimum distance combustible material can be fitted above the cooker in line with the edges of the cooker is 420 mm. If it is fitted below 420 mm. a space of 50 mm. must be allowed from the edges of the cooker.

The minimum distance combustible material can be fitted directly above the cooker is 700 mm.

If a cooker hood/extractor is fitted above the cooker, a minimum distance of 685mm must be allowed between the extractor and the hob.

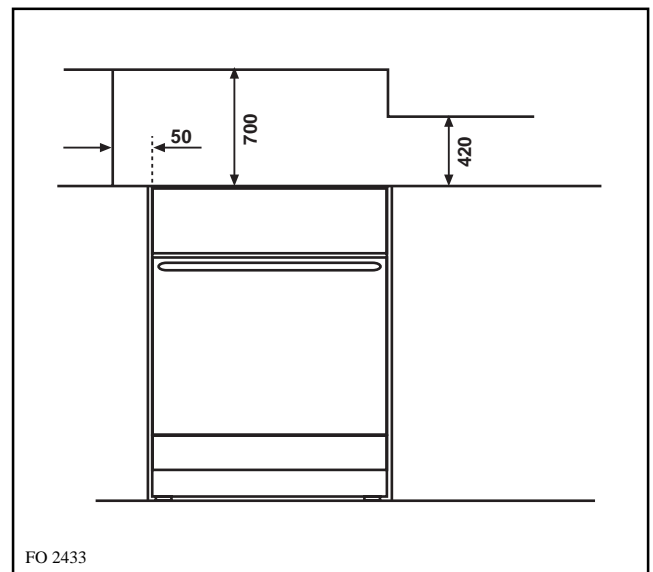

# Electrical connections



Any electrical work required to install this hob should be carried out by a qualified electrician or competent person, in accordance with the current regulations.



**THIS COOKER MUST BE EARTHED.**

**The manufacturer declines any liability should these safety measures not be observed.**

**This cooker is designed to be connected to a 230-240V 50Hz AC electrical supply.**

Before switching on, make sure the electricity supply voltage is the same as that indicated on the hob rating plate. The rating plate is located on the bottom of the hob. A copy is attached on the back cover of this book.

The cooker is supplied without supply cord. A 3 core flexible supply cord must be fitted, in accordance with the specification given in the relevant tables.

- 1) Loosen the two fixing screws securing the back protective screen of the cooker, then lift it up and remove it. This will expose the terminal block on the right bottom corner.
- 2) Loosen the two cable clamp screws and lift the top section of the clamp enough to allow the cable to be passed through.
- 3) Connect the red (live) wire to the terminal which is marked with the letter "L".
- 4) Connect the black (neutral) wire to the terminal which is marked with the letter "N".
- 5) After fitting a green or yellow/green sleeve over the bare copper wire (earth wire), connect the exposed end to the terminal which is marked with the earth symbol  $\perp$  or with the letter "E" coloured green and yellow.

**NOTE:**

The earth wire should be about 2 cm. longer than the live and neutral wires.

- 6) Secure the cable by means of the clamp screws and refit the back protective screen.

The cooker should be connected to a double pole switch with a minimum gap of 3 mm. between the switch contacts and of a type suitable for the required load in compliance with the current electric regulations. The switch should be sited within 2m of the hob and be easily accessible upon completion of the installation.

The switch must not break the yellow and green earth cable at any point.



Ensure that the hob supply cord does not come into contact with surfaces with temperatures higher than 50 deg. C.

## Supply Cable Specifications

### For Uk use only

Connection via	Min. size Cable/flex	Cable / flex type	Fuse
• Cooker Control Circuit	3 x 6 mm <sup>2</sup>	H05 VV-F	30 A

### For Europe use only

Min. size Cable/flex	Cable / flex type	Fuse
3x 2.5 mm <sup>2</sup>	H05 RR-F	30 A

