



**SISTF10xx-140-LR(T)**

## User's Guide

**SISTF10xx-140-LR(T)**

**SISTF10xx-160-LR(T)**

**SISTF10xx-170-LR(T)**

**Stand-Alone Ethernet Switch**

- **10Base-T / 100Base-TX to 100Base-FX**
- **Extended Temperature**
- **Hazardous Environment**

Transition Networks industrial Ethernet switch connects 10Base-T / 100Base-TX twisted-pair copper cable to 100Base-FX fiber-optic cable. It is designed for harsh industrial environments and is also available in models that operate in either standard or extended temperature ranges.

The **SISTF10xx-140-LR(T)** model includes four (4) copper RJ-45 ports and one (1) duplex fiber-optic port.

Part Number	Ports 1 - 4: Copper 10Base-T/100Base-TX	Port 5: Duplex Fiber-Optic 100Base-FX Duplex
-------------	--	---

Standard Temperature Models: 0°C to 60°C (32°F to 140°F):

<b>SISTF1011-140-LR</b>	RJ-45 100 m (328 ft)*	ST, 1300 nm multimode 2 km (1.2 miles)*
<b>SISTF1012-140-LR</b>	RJ-45 100 m (328 ft)*	ST, 1310 nm single mode 15 km (9.3 miles)*
<b>SISTF1013-140-LR</b>	RJ-45 100 m (328 ft)*	SC, 1300 nm multimode 2 km (1.2 miles)*
<b>SISTF1014-140-LR</b>	RJ-45 100 m (328 ft)*	SC, 1310 nm single mode 15 km (9.3 miles)*

Extended Temperature Models: -40°C to 75°C (-40°F to 167°F):

<b>SISTF1011-140-LRT</b>	RJ-45 100 m (328 ft)*	ST, 1300 nm multimode 2 km (1.2 miles)*
<b>SISTF1012-140-LRT</b>	RJ-45 100 m (328 ft)*	ST, 1310 nm single mode 15 km (9.3 miles)*
<b>SISTF1013-140-LRT</b>	RJ-45 100 m (328 ft)*	SC, 1300 nm multimode 2 km (1.2 miles)*
<b>SISTF1014-140-LRT</b>	RJ-45 100 m (328 ft)*	SC, 1310 nm single mode 15 km (9.3 miles)*

\* Typical maximum cable distance. Actual distance is dependent upon the physical characteristics of the network installation.

Installation	4
Operation	5
Cable Specifications	12
Technical Specifications	15
Troubleshooting	17
Compliance Information	20

**SISTF10xx-140-LR(T) / -160-LR(T) / -170-LR(T)**



The **SISTF10xx-160-LR(T)** model includes six (6) copper RJ-45 ports and two (2) duplex fiber-optic ports.

Part Number	Ports 1 - 6: Copper 10Base-T/100Base-TX	Ports 7 & 8: Duplex Fiber-Optic 100Base-FX Duplex
-------------	--	--

Standard Temperature Models: 0°C to 60°C (32°F to 140°F):

<b>SISTF1011-160-LR</b>	RJ-45 100 m (328 ft)*	ST, 1300 nm multimode 2 km (1.2 miles)*
<b>SISTF1012-160-LR</b>	RJ-45 100 m (328 ft)*	ST, 1310 nm single mode 15 km (9.3 miles)*
<b>SISTF1013-160-LR</b>	RJ-45 100 m (328 ft)*	SC, 1300 nm multimode 2 km (1.2 miles)*
<b>SISTF1014-160-LR</b>	RJ-45 100 m (328 ft)*	SC, 1310 nm single mode 15 km (9.3 miles)*

Extended Temperature Models: -40°C to 75°C (-40°F to 167°F):

<b>SISTF1011-160-LRT</b>	RJ-45 100 m (328 ft)*	ST, 1300 nm multimode 2 km (1.2 miles)*
<b>SISTF1012-160-LRT</b>	RJ-45 100 m (328 ft)*	ST, 1310 nm single mode 15 km (9.3 miles)*
<b>SISTF1013-160-LRT</b>	RJ-45 100 m (328 ft)*	SC, 1300 nm multimode 2 km (1.2 miles)*
<b>SISTF1014-160-LRT</b>	RJ-45 100 m (328 ft)*	SC, 1310 nm single mode 15 km (9.3 miles)*

\* Typical maximum cable distance. Actual distance is dependent upon the physical characteristics of the network installation.



The **SISTF10xx-170-LR(T)** model includes seven (7) copper RJ-45 ports and one (1) duplex fiber-optic port.

Part Number	Ports 1 - 7: Copper 10Base-T/100Base-TX	Port 8: Duplex Fiber-Optic 100Base-FX Duplex
-------------	--	---

Standard Temperature Models: 0°C to 60°C (32°F to 140°F):

<b>SISTF1011-170-LR</b>	RJ-45 100 m (328 ft)*	ST, 1300 nm multimode 2 km (1.2 miles)*
<b>SISTF1012-170-LR</b>	RJ-45 100 m (328 ft)*	ST, 1310 nm single mode 15 km (9.3 miles)*
<b>SISTF1013-170-LR</b>	RJ-45 100 m (328 ft)*	SC, 1300 nm multimode 2 km (1.2 miles)*
<b>SISTF1014-170-LR</b>	RJ-45 100 m (328 ft)*	SC, 1310 nm single mode 15 km (9.3 miles)*

Extended Temperature Models: -40°C to 75°C (-40°F to 167°F):

<b>SISTF1011-170-LRT</b>	RJ-45 100 m (328 ft)*	ST, 1300 nm multimode 2 km (1.2 miles)*
<b>SISTF1012-170-LRT</b>	RJ-45 100 m (328 ft)*	ST, 1310 nm single mode 15 km (9.3 miles)*
<b>SISTF1013-170-LRT</b>	RJ-45 100 m (328 ft)*	SC, 1300 nm multimode 2 km (1.2 miles)*
<b>SISTF1014-170-LRT</b>	RJ-45 100 m (328 ft)*	SC, 1310 nm single mode 15 km (9.3 miles)*

\* Typical maximum cable distance. Actual distance is dependent upon the physical characteristics of the network installation.

## Installation

### DIN-Rail Mount

The Ethernet switch includes an aluminum DIN-Rail mounting plate attached to the device's back panel. To mount the device onto a DIN-Rail:

1. Insert the top of the DIN-Rail into the upper slot of the mounting plate. The stiff metal spring should be positioned behind the DIN-Rail.
2. Push down and rotate the device to snap it into place on the DIN-Rail as shown.

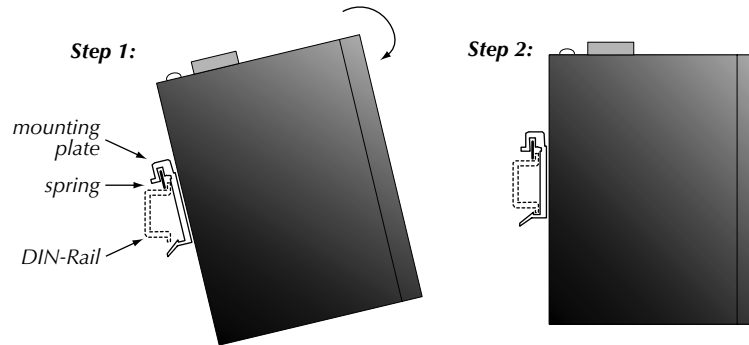

**NOTE:** The Ethernet switch is intended to be grounded to a well-grounded mounting surface such as a metal plate. Install the grounding wire prior to connecting any other device.

### Ground the Ethernet Switch

Grounding the Ethernet switch helps limit the effects of noise due to electromagnetic interference (EMI). The grounding screw is located on the top panel next to the terminal block.

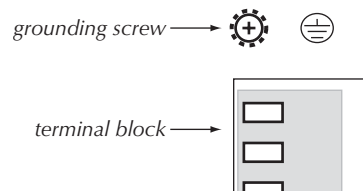

To ground the device:

1. Connect one end of the grounding wire (not included) to the grounding screw by looping one end of the grounding wire under the star washer.
2. Tighten the grounding screw with a phillips-head screwdriver.
3. Connect the other end of the grounding wire to earth ground.

## Installation -- Continued



**CAUTION:** Disconnect the Ethernet switch from the DC power source BEFORE installing and/or wiring the device.

### Install the Fiber Cable

1. Locate or build 100Base-FX fiber cable with male, two-stranded TX to RX connectors installed at both ends.
2. Connect the fiber cables to the Ethernet switch as described:
  - Connect the male **TX** cable connector to the female **TX** port.
  - Connect the male **RX** cable connector to the female **RX** port.
3. Connect the fiber cables to the other device (another media converter, hub, etc.) as described:
  - Connect the male **TX** cable connector to the female **RX** port.
  - Connect the male **RX** cable connector to the female **TX** port.

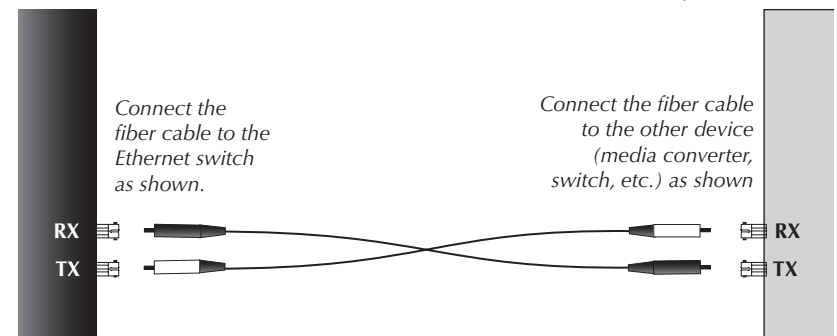

### Install the Copper Cable

The AutoCross feature allows either straight-through (MDI) or crossover (MDI-X) copper cable to be used when connecting devices via the RJ-45 port.

1. Locate or build 10Base-T or 100Base-TX copper cables with male, RJ-45 connectors installed at both ends.
2. Connect the RJ-45 connector at one end of the cable to the RJ-45 port on the Ethernet switch.
3. Connect the RJ-45 connector at the other end of the cable to the RJ-45 port on the other device (PLC, workstation, etc.).



## Installation -- Continued

### Set the Port Alarm Switches

The port alarm feature is used to determine faults at the copper or fiber ports. The dip switches are located on the top panel of the device. Use a small flat blade screwdriver or a similar device to set the switches.

#### SISTF10xx-140-LR(T)

- Switches 1 - 4 correspond to copper ports 1 - 4, respectively.
- Switch 5 corresponds to fiber port 5.

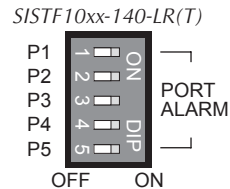

#### SISTF10xx-160-LR(T)

- Switches 1 - 6 correspond to copper ports 1 - 6, respectively.
- Switches 7 and 8 correspond to fiber ports 7 and 8, respectively.

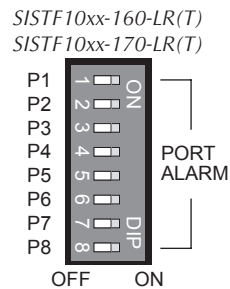

#### SISTF10xx-170-LR(T)

- Switches 1 - 7 correspond to copper ports 1 - 7, respectively.
- Switch 8 corresponds to fiber port 8.

**on** = Enables the corresponding port alarm. If the link for that port fails (or if a power supply input fails), the internal relay forms an open circuit and the FAULT LED lights up.

**off** = Disables the corresponding port alarm. The internal relay forms a closed circuit and the FAULT LED remains off.



**NOTE:** To activate the updated switch setting, cycle the power to the Ethernet switch by turning off the power, then turning it back on.

### Internal Relay

The internal relay that activates the alarm feature is connected to the two middle contacts on the 6-contact terminal block. A user-supplied fault alarm device can be connected to these fault contacts. An example would be to connect the fault circuit to a warning light located in the control room. The light can be set up to turn on when a fault is detected. (See page 7.)

## Installation -- Continued

### Install the Port Alarm Device

A user-supplied port alarm device can be connected to the Ethernet switch to alert the user whenever a power fault or a port fault occurs. At least one port alarm switch (see page 6) must be "ON" to enable the port alarm feature.

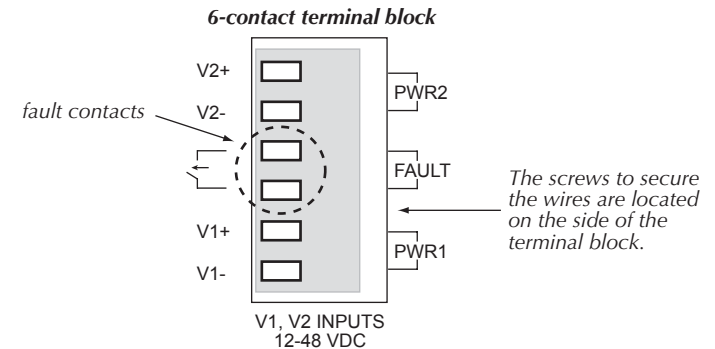

The contacts for the fault alarm are on the 6-contact terminal block, located on the top panel of the Ethernet switch. To install a port alarm device:

1. Insert the two wires from the user-supplied port alarm device into the two terminals marked "FAULT" on the 6-contact terminal block.
2. Secure the wire by tightening the corresponding screw on the side of the terminal block.



**NOTE:** Calculate the maximum possible current in each power wire and signal wire. Observe all electrical codes for maximum current allowed. If the current goes above the maximum ratings, the wiring would overheat, causing serious damage to the network equipment.

#### Please note the following when wiring the network:

- Signal lines must not be directly connected to outdoor wiring.
- Use separate paths to route the power wiring and the signal wiring. If power wiring and signal wiring paths must cross, make sure the wires are perpendicular at the intersection point.
- Do not run signal wiring and power wiring in the same wire conduit. To avoid interference, wires with different signal characteristics should also be routed separately.
- Use the type of signal transmitted through a wire to determine which wires should be kept separate. The rule of thumb is that wiring with similar electrical characteristics can be bundled together.
- Keep input wiring and output wiring separate.
- Where necessary, label the wiring to all devices in the network.

## Installation -- Continued

### Power the Ethernet switch

This device is suitable for use in Class I, Division 2, Groups A, B, C and D or non-hazardous locations only.



**WARNING: EXPLOSION HAZARD** - Do not disconnect equipment unless power has been removed or the area is known to be non-hazardous.



**WARNING: EXPLOSION HAZARD** - Substitution of components may impair suitability for Class I, Division 2.

The Ethernet switch is designed for both a primary and a backup power supply via the 6-contact terminal block, located on the top panel of the device. Both power inputs can be connected simultaneously to live DC power sources. If one power source fails, the other live source acts as a backup, and automatically supplies the Ethernet switch with power.

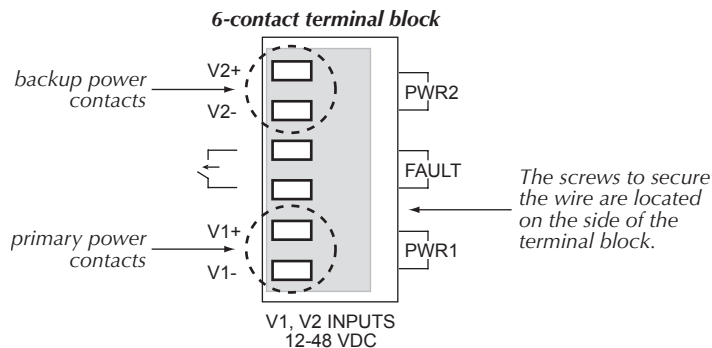

**CAUTION:** Before connecting the Ethernet switch to the 12-48 VDC power source, ensure the power source voltage is stable.

#### To provide PRIMARY (PWR1) power to the Ethernet switch:

1. Insert the positive (+) DC wire from the 12-48VDC power source into the terminal marked "V1+".
2. Insert the negative (-) DC wire into the terminal marked "V1-".
3. Secure the wires by tightening the corresponding screws on the side of the terminal block.

#### To provide BACKUP (PWR2) power to the Ethernet switch:

1. Insert the positive (+) DC wire from the 12-48VDC power source into the terminal marked "V2+".
2. Insert the negative (-) DC wire into the terminal marked "V2-".
3. Secure the wires by tightening the corresponding screws on the side of the terminal block.

## Operation

### Features

#### Auto-Negotiation

With the Auto-Negotiation feature, the Ethernet switch automatically configures itself to achieve the best possible mode of operation over the copper link. The device broadcasts its speed (10 Mb/s or 100 Mb/s) and duplex capabilities (either full- or half-duplex) and negotiates the best mode of operation between the two linked devices.

If the device is connected to a non-negotiating device over the copper link, it will default to 10 Mb/s speed, half-duplex mode.

#### AutoCross

The AutoCross feature allows either straight-through (MDI) or crossover (MDI-X) cables to be used when connecting the Ethernet switch to devices such as PLCs or workstations. AutoCross determines the characteristics of the cable connection and automatically configures the unit to link up, regardless of the cable configuration. (Requires no operator intervention.)

#### Plug-and-Play

The Ethernet switch models are plug-and-play devices, so that software configuration is not required at installation or during maintenance.

#### Switching, Filtering, and Forwarding

Packets are either filtered or forwarded when they arrive at one of the switched ports.

- Packets with source and destination addresses belonging to the same port segment are filtered and constrained to one port (relieving the rest of the network from the need to process them).
- Packets with a destination address to another port segment are forwarded to the appropriate port, and are not sent to the other ports where it is not needed.
- Packets that are used in maintaining the operation of the network (such as the occasional multi-cast packet) are forwarded to all ports.

The Ethernet switch operates in the store-and-forward switching mode, which eliminates bad packets and enables peak performance to be achieved when there is heavy traffic on the network.

#### Switching and Address Learning

The Ethernet switch address table holds up to 1K node addresses, making it suitable for use with large networks. The address tables are self-learning, so that as nodes are added, removed, or moved from one segment to another, the Ethernet switch automatically keeps up with new node locations. An address-aging algorithm deletes the least-used addresses in favor of newer, more frequently used addresses. To reset the address buffer, power down the unit and then power it back up.

## Operation -- Continued

### Status LEDs

Use the status LEDs to monitor the Ethernet switch operation in the network.

#### Power and Fault LEDs

The three LEDs near the top indicate the power and fault status:

**PWR1** (amber) **on** = Primary power is connected to device.

**PWR2** (amber) **on** = Backup power is connected to the device.

**FAULT** (red) **on** = If any of the five (5) port alarm switches are “on” and the link on the corresponding port is inactive (ex: switch 3 is “on” and port 3 is inactive); or there is a loss of either the primary power or backup power.

#### Fiber Port LEDs

The “100M” LEDs indicate the link status of the corresponding fiber port (100Base-FX):

**100M** (green) **on** = Fiber link is active.

**flashing** = Data is being transmitted over the fiber link.

#### Copper Port LEDs

The LEDs embedded in each of the RJ-45 port indicate the status of the corresponding copper link (10/100Base-T/TX):

**10M** (green) **on** = Copper link is active at 10 Mb/s.

**flashing** = Data is being transmitted over the copper link at 10 Mb/s.

**100M** (green) **on** = Copper link is active at 100 Mb/s.

**flashing** = Data is being transmitted over the copper link at 100 Mb/s.

## Operation -- Continued

SISTF10xx-140-LR(T)

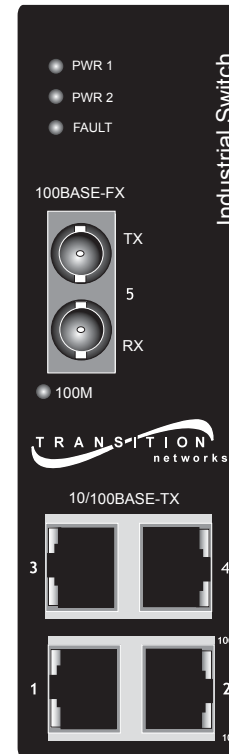

SISTF10xx-160-LR(T)

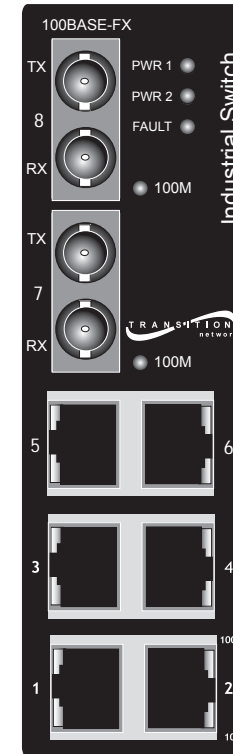

SISTF10xx-170-LR(T)

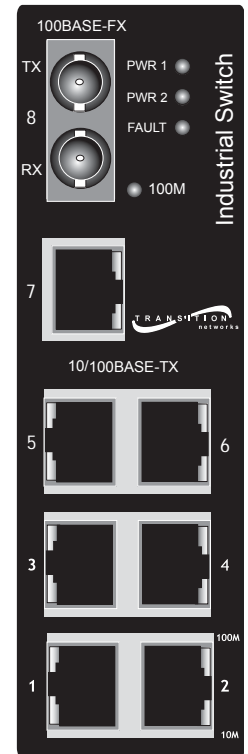



## Cable Specifications

The physical characteristics must meet or exceed IEEE 802.3™ specifications.

### Fiber Cable

Bit Error Rate:	<10 <sup>-9</sup>
Single mode fiber (recommended):	9 μm
Multimode fiber (recommended):	62.5/125 μm
Multimode fiber (optional):	100/140, 85/140, 50/125 μm

### Standard Models

<b>SISTF1011-140-LR</b>	
<b>SISTF1011-160-LR</b>	
<b>SISTF1011-170-LR</b>	1300 nm multimode
Fiber Optic Transmitter Power:	min: -20.0 dBm    max: -14.0 dBm
Fiber Optic Receiver Sensitivity:	min: -36.0 dBm    max: -32.0 dBm
Link Budget:	16.0 dB

<b>SISTF1012-140-LR</b>	
<b>SISTF1012-160-LR</b>	
<b>SISTF1012-170-LR</b>	1310 nm single mode
Fiber Optic Transmitter Power:	min: -15.0 dBm    max: -6.0 dBm
Fiber Optic Receiver Sensitivity:	min: -34.0 dBm    max: -32.0 dBm
Link Budget:	19.0 dB

<b>SISTF1013-140-LR</b>	
<b>SISTF1013-160-LR</b>	
<b>SISTF1013-170-LR</b>	1300 nm multimode
Fiber Optic Transmitter Power:	min: -20.0 dBm    max: -14.0 dBm
Fiber Optic Receiver Sensitivity:	min: -36.0 dBm    max: -32.0 dBm
Link Budget:	16.0 dB

<b>SISTF1014-140-LR</b>	
<b>SISTF1014-160-LR</b>	
<b>SISTF1014-170-LR</b>	1310 nm single mode
Fiber Optic Transmitter Power:	min: -15.0 dBm    max: -6.0 dBm
Fiber Optic Receiver Sensitivity:	min: -34.0 dBm    max: -32.0 dBm
Link Budget:	19.0 dB

## Cable Specifications -- Continued

### Extended Temperature Models

<b>SISTF1011-140-LRT</b>	
<b>SISTF1011-160-LRT</b>	
<b>SISTF1011-170-LRT</b>	1300 nm multimode
Fiber Optic Transmitter Power:	min: -20.0 dBm    max: -14.0 dBm
Fiber Optic Receiver Sensitivity:	min: -36.0 dBm    max: -32.0 dBm
Link Budget:	16.0 dB

<b>SISTF1012-140-LRT</b>	
<b>SISTF1012-160-LRT</b>	
<b>SISTF1012-170-LRT</b>	1310 nm single mode
Fiber Optic Transmitter Power:	min: -15.0 dBm    max: -6.0 dBm
Fiber Optic Receiver Sensitivity:	min: -34.0 dBm    max: -32.0 dBm
Link Budget:	19.0 dB

<b>SISTF1013-140-LRT</b>	
<b>SISTF1013-160-LRT</b>	
<b>SISTF1013-170-LRT</b>	1300 nm multimode
Fiber Optic Transmitter Power:	min: -20.0 dBm    max: -14.0 dBm
Fiber Optic Receiver Sensitivity:	min: -36.0 dBm    max: -32.0 dBm
Link Budget:	16.0 dB

<b>SISTF1014-140-LRT</b>	
<b>SISTF1014-160-LRT</b>	
<b>SISTF1014-170-LRT</b>	1310 nm single mode
Fiber Optic Transmitter Power:	min: -15.0 dBm    max: -6.0 dBm
Fiber Optic Receiver Sensitivity:	min: -34.0 dBm    max: -32.0 dBm
Link Budget:	19.0 dB

This device is certified by the manufacturer to comply with DHHS Rule 21/CFR, Subchapter J applicable at the date of manufacture.

The fiber optic transmitters on this device meet Class I Laser safety requirements per IEC-825/CDRH standards and comply with 21 CFR1040.10 and 21CFR1040.11.



**CAUTION:** Visible and invisible laser radiation when open. Do not stare into beam or view directly with optical instruments.



**CAUTION:** Use of controls, adjustments or the performance of procedures other than those specified herein may result in hazardous radiation exposure.

## Cable Specifications -- Continued

### Copper Cable

**Category 5:** (minimum requirement)

Gauge / Attenuation: 24 to 22 AWG / 22.0 dB per 100m @ 100 MHz

- Straight-through **OR** crossover cable may be used.
- Shielded twisted-pair (STP) **OR** unshielded twisted-pair (UTP) may be used
- Pins 1&2 and 3&6 are the two active pairs in an Ethernet network .
- RJ-45 Pin-out: Pin 1 = TD+, Pin 2 = TD-, Pin 3 = RD+, Pin 6 = RD-
- Use only dedicated wire pairs for the active pins:  
(e.g., blue/white & white/blue, orange/white & white/orange, etc.)
- Do not use flat or silver satin wire.

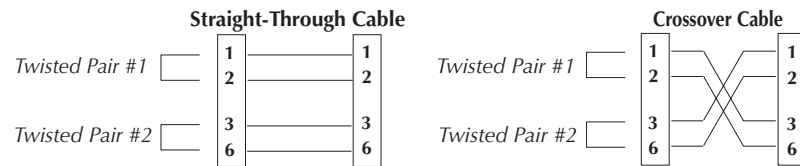

## Technical Specifications

For use with Transition Networks Model Ethernet switch or equivalent

<b>Standards:</b>	IEEE 802.3™, 802.3u™; 802.3x™
<b>Data Rate:</b>	10 Mb/s, 100 Mb/s (copper); 100 Mb/s (fiber)
<b>Processing Type:</b>	Store and Forward w/ IEEE802.3x™ full-duplex, non-blocking flow control
<b>Dimensions:</b>	1.8" x 5.3" x 4.1" (46 mm x 135 mm x 105 mm)
<b>Weight:</b>	1.4 lb. (0.63 kg) (approximate)
<b>Input Voltage:</b>	12-48VDC, 0.2-0.7A, 2.4W (minimum), (redundant inputs)
<b>Input Current:</b>	0.25 A @ 24 VDC ( <i>SISTF10xx-140-LR(T)</i> ) 0.35 A @ 24 VDC ( <i>SISTF10xx-160-LR(T) / -170-LR(T)</i> )
<b>Overload Current:</b>	1.1 A ( <i>SISTF10xx-140-LR(T)</i> ) 1.6 A ( <i>SISTF10xx-160-LR(T) / -170-LR(T)</i> ) reverse polarity protection on all models
<b>Forward &amp; Filtering:</b>	148810 pps
<b>Packet Buffer:</b>	256 KB
<b>Address Table Size:</b>	1000 Unicast MAC addresses
<b>Latency:</b>	< 5 μs
<b>Alarm Relay:</b>	1.0 A @ 24 VDC
<b>Mechanical:</b>	Ingress Protection: IP30
<b>Environment:</b>	Tmra* ( <b>standard temp</b> ): 0 to 60°C (32 to 140°F) Tmra* ( <b>extended temp</b> ): -40 to 75°C (-40 to 167°F) Storage Temperature: -40 to 85°C (-40 to 185°F) Humidity: 5 to 95%, non condensing
<b>Warranty:</b>	Lifetime

\*Manufacturer's rated ambient temperature.

The information contained in this user's guide is subject to change. For the most up-to-date information see the user's guide on line at: [www.transition.com](http://www.transition.com).



**CAUTION:** This device is intended to be supplied by a listed power unit marked LPS or Limited Power Source, provided with a connector for field wiring terminal, and output rated 12-48VDC, 0.2-0.7 A, 24 W minimum.



**CAUTION:** This device is designed for operation with a safety extra-low voltage (SELV) in compliance with IEC950 / EN60950 / VDE0805 and in compliance with the low voltage directive 73/23/EEC and 93/68/EEC.



## Technical Specification -- Continued

This device has been evaluated as EEx nC IIC T4 equipment under DEMKO Certificate No. 03 ATEX 0324537U. Each module is suitable for use in Zone 2 Explosive Atmospheres. The device must be installed in a minimum IP 54 enclosure as defined in IEC 60529 and EN 60529.

This device is a building-in type. The installation into a certain end equipment shall comply with fire enclosure request of IEC 60950/EN60950 or similar sentence.

### EMS Type Tests

Test	Description	Test Levels	Severity	
IEC61000-4-2	ESD	Air discharge	+/- 8 KV	3
		Contact discharge	+/- 6 KV	3
		ESD contact discharge	+/- 6 KV	3
IEC61000-4-3	Radiated RFI	Housing	10V/m, 80 MHz - 1 GHz AM 1 KHz, 80% mod 10 V/m, 0.9 - 1.8 GHz FM 200 Hz 50% square	3
IEC61000-4-4	Burst (Fast Transient)	Power supply lines	+/- 2 KV	3
		Communication lines	+/- 1 KV	3
		Relay	+/- 1 KV	3
IEC61000-4-5	Surge	Power supply lines	+/- 2 KV, 12 Ω, CM +/- 1 KV, 2 Ω, DM	3
		Relay	+/- 2 KV, 12 Ω, CM +/- 1 KV, 2 Ω, DM	3
IEC61000-4-6	Induced (Conducted RFI)	Power supply lines	10 Vrms, 150-80 MHz AM 1 KHz, 80% mod	3
		Communication lines	10 Vrms, 150-80 MHz AM 1 KHz, 80% mod	3
		Relay	10 Vrms, 150-80 MHz AM 1 KHz, 80% mod	3

### Environmental Type Tests

Test	Description	Test Levels
IEC 60068-2-6	Vibration	10 - 500 - 10 Hz, 0.5 oct./min, 4g, X, Y, Z (3 axes)
IEC 60068-2-27	Shock	50 g, 11 ms, +/-X, +/-Y, +/- Z (6 direction)
IEC 60068-2-32	Free fall	75 cm, 1 corner, 3 edges, 6 faces (total 10 drops)

## Troubleshooting

If the device fails, isolate and correct the fault by determining the answers to the following questions and then taking the indicated action:

### 1. Is the PWR1 LED illuminated?

#### NO

- Ensure the power source is the proper voltage (12 - 48 VDC).
- Ensure the (+) and (-) wires from the power source are inserted properly in the terminal block contacts labeled "PWR1".
- Contact Tech Support: 800-260-1312, Int'l: 00-1-952-941-7600.

#### YES

- Proceed to step 2.

### 2. Is the PWR2 LED illuminated?

#### NO

- Ensure the power source is the proper voltage (12 - 48 VDC).
- Ensure the (+) and (-) wires from the power source are inserted properly in the terminal block contacts labeled "PWR2".
- Contact Tech Support: 800-260-1312, Int'l: 00-1-952-941-7600.

#### YES

- Proceed to step 3.

### 3. Is the FAULT LED illuminated?

#### YES

- If one or more port alarm switches (1 - 5) is **ON**, the device lost the corresponding fiber or copper link, or the primary power or backup power.
- Ensure the problem copper or fiber link is properly connected.
- Contact Tech Support: 800-260-1312, Int'l: 00-1-952-941-7600.

#### NO

- Proceed to step 4.

### 4. Is a 100M LED (near a fiber link) illuminated?

#### NO

- Check the corresponding fiber cables for proper connection.
- Verify that the TX and RX cables on the device are connected to the RX and TX ports, respectively, on the other device.
- Contact Tech Support: 800-260-1312, Int'l: 00-1-952-941-7600.

#### YES

- Proceed to step 5.

## Troubleshooting -- Continued

### 5. Is a 100M LED (near the fiber links) flashing?

#### NO

- If there is activity on the corresponding fiber port, disconnect and reconnect the fiber cable to restart the initialization process.
- If there is no activity on the corresponding fiber port, contact Tech Support: 800-260-1312, Int'l: 00-1-952-941-7600.

#### YES

- Proceed to step 6.

### 6. Are any of the 10M LEDs (on the RJ-45 port) illuminated?

#### YES

- The device has selected 10 Mb/s for the twisted-pair link.
- If the speed is not correct, disconnect and reconnect the twisted-pair cable to restart the initialization process.
- Proceed to step 7.

#### NO

- Proceed to step 7.

### 7. Are any of the 100M LEDs (on the RJ-45 port) illuminated?

#### YES

- The device has selected 100 Mb/s for the twisted-pair link.
- If the speed is not correct, disconnect and reconnect the twisted-pair cable to restart the initialization process.
- Contact Tech Support: 800-260-1312, Int'l: 00-1-952-941-7600.

#### NO

- Check the twisted-pair cables for proper connection.
- Contact Tech Support: 800-260-1312, Int'l: 00-1-952-941-7600.

## Contact Us

### Technical Support

Technical support is available 24 hours a day

US and Canada: **1-800-260-1312**

International: **00-1-952-941-7600**

### Transition Now

Chat live via the Web with Transition Networks Technical Support.

Log onto **www.transition.com** and click the **Transition Now** link.

### Web-Based Seminars

Transition Networks provides seminars via live web-based training.

Log onto **www.transition.com** and click the **Learning Center** link.

### E-Mail

Ask a question anytime by sending an e-mail to our technical support staff.

**techsupport@transition.com**

### Address

Transition Networks, 6475 City West Parkway, Minneapolis, MN 55344, USA  
 telephone: 952-941-7600, toll free: 800-526-9267, fax: 952-941-2322

TRANSITION networks		Declaration of Conformity
Name of Mfg:	<b>Transition Networks</b> 6475 City West Parkway, Minneapolis MN 55344, USA	
Model:	<b>Ethernet Switch Series Redundant Ring Industrial Switches</b>	
Part Number(s):	<b>SISTF1011-140-LR, SISTF1012-140-LR, SISTF1013-140-LR,            SISTF1014-140-LR, SISTF1011-140-LRT, SISTF1012-140-LRT,            SISTF1013-140-LRT, SISTF1014-140-LRT            SISTF1011-160-LR, SISTF1012-160-LR, SISTF1013-160-LR,            SISTF1014-160-LR, SISTF1011-160-LRT, SISTF1012-160-LRT,            SISTF1013-160-LRT, SISTF1014-160-LRT            SISTF1011-170-LR, SISTF1012-170-LR, SISTF1013-170-LR,            SISTF1014-170-LR, SISTF1011-170-LRT, SISTF1012-170-LRT,            SISTF1013-170-LRT, SISTF1014-170-LRT</b>	
Regulation:	<b>EMC Directive 89/336/EEC</b>	
Purpose:	To declare that the <b>Ethernet Switch</b> to which this declaration refers is in conformity with the following standards.	
	EN 55022:1998 Class A; FCC Part 15 Subpart B; 21CFR subpart J;	
	UL 60950; UL 508; CSA C22.2 no 60950; EN 60950;	
	UL/cUL Class 1, Div 2, Groups A, B, C, D; ATEX Class 1, Zone 2, EExnC IIC;	
	EN61000-4-2, -4-3, -4-4, -4-5, -4-6; IEC 60068-2-6, -2-27, -2-32	
	<b>I, the undersigned, hereby declare that the equipment specified above conforms to the above Directive(s) and Standard(s).</b>	
		December 3, 2004
	Stephen Anderson, Vice-President of Engineering	Date

**NOTE:** The following part numbers are UL listed: SISTF1013-140-LR, SISTF1013-140-LRT, SISTF1014-140-LR, SISTF1014-140-LRT, SISTF1013-160-LR, SISTF1013-160-LRT, SISTF1014-160-LR, SISTF1014-160-LRT, SISTF1013-170-LR, SISTF1013-170-LRT, SISTF1014-170-LR, SISTF1014-170-LRT,

---

# Compliance Information

## UL Listed; C-UL Listed (Canada)

**NOTE:** The following part numbers are UL listed: SISTF1013-140-LR, SISTF1013-140-LRT, SISTF1014-140-LR, SISTF1014-140-LRT, SISTF1013-160-LR, SISTF1013-160-LRT, SISTF1014-160-LR, SISTF1014-160-LRT, SISTF1013-170-LR, SISTF1013-170-LRT, SISTF1014-170-LR, SISTF1014-170-LRT.

## CISPR22/EN55022 Class A; CE Mark

### FCC Regulations

This equipment has been tested and found to comply with the limits for a Class A digital device, pursuant to part 15 of the FCC rules. These limits are designed to provide reasonable protection against harmful interference when the equipment is operated in a commercial environment. This equipment generates, uses, and can radiate radio frequency energy and, if not installed and used in accordance with the instruction manual, may cause harmful interference to radio communications. Operation of this equipment in a residential area is likely to cause harmful interference, in which case the user will be required to correct the interference at the user's own expense.

### Canadian Regulations

This digital apparatus does not exceed the Class A limits for radio noise for digital apparatus set out on the radio interference regulations of the Canadian Department of Communications. Le présent appareil numérique n'émet pas de bruits radioélectriques dépassant les limites applicables aux appareils numériques de la Class A prescrites dans le Règlement sur le brouillage radioélectrique édicté par le ministère des Communications du Canada.

### European Regulations

#### Warning

This is a Class A product. In a domestic environment this product may cause radio interference in which case the user may be required to take adequate measures.

#### Achtung !

Dieses ist ein Gerät der Funkstörgrenzwertklasse A. In Wohnbereichen können bei Betrieb dieses Gerätes Rundfunkstörungen auftreten. In diesem Fall ist der Benutzer für Gegenmaßnahmen verantwortlich.

#### Attention !

Ceci est un produit de Classe A. Dans un environnement domestique, ce produit risque de créer des interférences radioélectriques, il appartiendra alors à l'utilisateur de prendre les mesures spécifiques appropriées.



**CAUTION: RJ connectors are NOT INTENDED FOR CONNECTION TO THE PUBLIC TELEPHONE NETWORK. Failure to observe this caution could result in damage to the public telephone network.**

**Der Anschluss dieses Gerätes an ein öffentliches Telekommunikationsnetz in den EG-Mitgliedstaaten verstösst gegen die jeweiligen einzelstaatlichen Gesetze zur Anwendung der Richtlinie 91/263/EWG zur Angleichung der Rechtsvorschriften der Mitgliedstaaten über Telekommunikationsendeinrichtungen einschliesslich der gegenseitigen Anerkennung ihrer Konformität.**

### Trademark Notice

All trademarks and registered trademarks are the property of their respective owners.

### Copyright Restrictions

© 2004 Transition Networks.

All rights reserved. No part of this work may be reproduced or used in any form or by any means - graphic, electronic, or mechanical - without written permission from Transition Networks.

Printed in the U.S.A.

**33311.A**

---