

INSTRUCTION MANUAL

the **first years**®

True Fit

Convertible carseat

Model 630



⚠ WARNING ⚠

DEATH or SERIOUS INJURY can occur

- Failure to use this Convertible Seat properly increases the risk of serious injury or death in a sudden stop or crash.
- Do not install or use this Convertible Seat until you have read and understood the instructions in this manual.

Section 1 - Introduction

Dear Parents,

Thank you for purchasing *The First Years C630 True Fit*. We hope that it will make your baby's travel safer, easier, and more comfortable.

We believe the *True Fit* is the easiest Convertible Seat to use. We do more testing than most companies to make it as safe as possible. And, we use the latest methods to assure the highest quality.

We have tried very hard to keep our instructions simple and understandable. We apologize for beginning our instructions with so many warnings but they are very important for you to properly restrain your child. Read and understand all of the instructions and warnings. The safety of your child depends on it!

If you have any questions or need assistance, please contact the **highly trained First Years Staff at 1-888-899-2229.**

**Keep this instruction manual for future use.
Store in pocket on the back of Convertible Seat.**

***No car seat can guarantee protection from injury
in every situation, but proper use helps reduce
the risk of serious injury or death.***

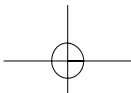

Section 2 - Table Of Contents

Section 1 Introduction.....1

Section 2 Table Of Contents.....2

Section 3 Warnings.....4

Section 4 Use Recommendations.....6

Section 5 Convertible Seat Parts.....9

Section 6 Selecting A Vehicle Seating Location....11

Section 7 Installation and Use.....19

7.1 Forward Facing w/ Auto Belt.....19

7.2 Forward Facing w/ LATCH.....23

7.3 Rear Facing w/ Auto Belt.....25

7.4 Rear Facing with LATCH.....29

7.5 Aircraft Use.....33

7.6 Child Placement in Restraint.....34

7.7 Selecting Harness Height.....35

7.8 Shoulder Height Adjustment.....36

7.9 Tether Storage.....36

7.10 5 Pt. Buckle.....37

7.11 Chest Clip.....38

7.12 Adjust Harness Tension.....39

Section 2 - Table Of Contents

Section 7 Installation and Use - continued

7.13 2 Position Crotch Buckle Adjustment	40
7.14 Seat Insert Use.....	40
7.15 Harness Length Adjustment.....	41
7.16 Recline Foot Adjustment.....	42
7.17 Upper Seatback Removal.....	43
7.18 Upper Seatback Installation	44
7.19 Pad Removal	45
7.20 Installation Pictograms	47

Section 8 Safety Checklist/Safe Practices.....48

Section 9 Additional Information.....50

Section 10 Care and Cleaning.....51

Section 11 Replacement Parts.....51

Section 3 - Warnings

⚠ WARNING ⚠ **DEATH or SERIOUS INJURY can occur**

- Failure to follow these instructions and Convertible Seat labels can result in injury or death to a child from striking the vehicle's interior during a sudden stop or crash.
 - Even if the Convertible Seat seems easy to use on your own, it is important to read these instructions and the vehicle owner's manual for details you might miss.
- The instructions in this manual and in your vehicle owner's manual must be followed carefully. If there is a conflict between the two, the vehicle owner's manual must be followed if it relates to the vehicle's seat belt, LATCH or airbags.
- Failure to use the automobile seat belt or LATCH or to adjust it properly can result in your child striking the vehicle's interior during a sudden stop or crash. Serious injury or death can occur.
- DO NOT allow others (baby sitters, friends, grandparents, etc.) to use this Convertible Seat unless they read and understand the instructions and labels. and can demonstrate proper use to your satisfaction.
- Use only car seat accessories manufactured by The First Years. Accessories can affect your child's safety in a sudden stop or crash.
- DO NOT modify or attach any toys, padding, or other items to this Convertible Seat. Untested modifications or padding could result in injury in a crash.
- Secure this Convertible Seat with the vehicle seat belt or LATCH bars at all times (even when there is no child in it). An unsecured child restraint can injure others if a crash occurs.

WARNING

DEATH or SERIOUS INJURY can occur

- **Direct sunlight can make Convertible Seat surfaces hot enough to burn your child. Use caution and check the vehicle and Convertible Seat on hot, sunny days.**
- **NEVER leave child unattended under any circumstance**
- **DO NOT use this Convertible Seat if it has been in a crash. (There may be hidden damage and it must be replaced.) Your insurance company may provide some assistance replacing this convertible seat.**
- **DO NOT use this Convertible Seat if it is damaged in any way or has missing parts. Refer to section 5 for True Fit parts.**
- **STOP USING THIS Convertible Seat AND THROW IT AWAY after the date on the back of the seat. THROW IT AWAY in a dark trash bag.....Do Not sell to a thrift or consignment shops, garage sales or at flea markets.**
- **NEVER use this Convertible seat in the home, boats , motor homes with side facing seats or other non certified uses. Only use this restraint in Automobiles and Aircraft.**

Section 4 - Use Recommendations

The First Years advises parents that children should use a child restraint with a built-in harness system until they exceed the weight or height limits specified by the manufacturer.

C630 True Fit Convertible Seat Rear Facing Use Requirements:

This child restraint, **without** the upper seatback in a rear facing position is, designed for use by children whose:

- Weight is between 5 and 22 lbs (2,3 and 10 kg), and
- Head is 1 inch below the top of the seat.

Child **MUST** meet **BOTH** of these requirements to use this Convertible Seat without the upper seatback installed.

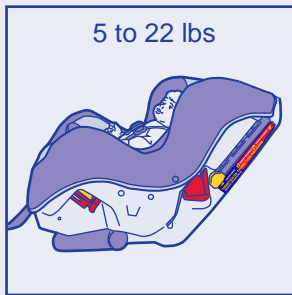
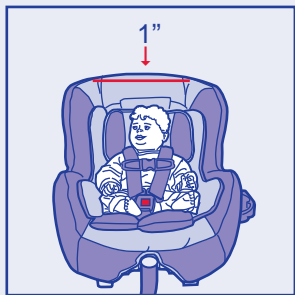

Rear Facing
Use Only

Section 4 - Use Recommendations

C630 True Fit Convertible Seat Rear Facing

Use Requirements:

This child restraint, **with** the upper seatback installed in a rear facing position, is designed for use by children whose:

- Weight is between 5 and 35 lbs (2,3 and 15,88 kg), and
- Head is 1 inch below the top of the seat.

Child **MUST** meet **BOTH** of these requirements to use this Convertible Seat.

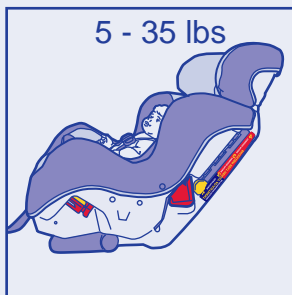
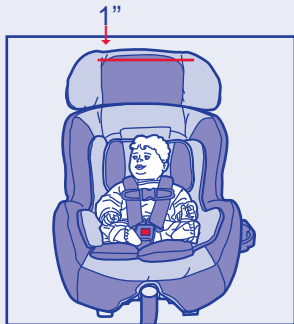

Section 4 - Use Recommendations

C630 True Fit Convertible Seat Forward Facing

Use Requirements:

This child restraint, with the upper seatback installed in a forward facing position, is designed for use by children whose:

- Weight is between 23 and 65 lbs (10,43 and 29 kg), and
- Height is 50 inches (127 cm) or less.
- Age is 1 year.

Child **MUST** meet **ALL** of these requirements to use this Convertible Seat forward facing.

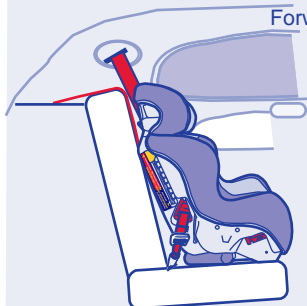
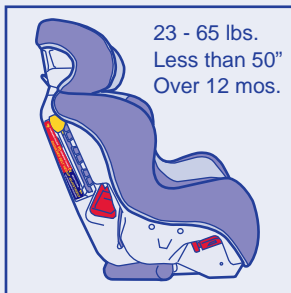

WARNING !

NEVER install the C630 True Fit in a forward facing position without the upper seat back installed.

Section 5 - Convertible Seat Parts

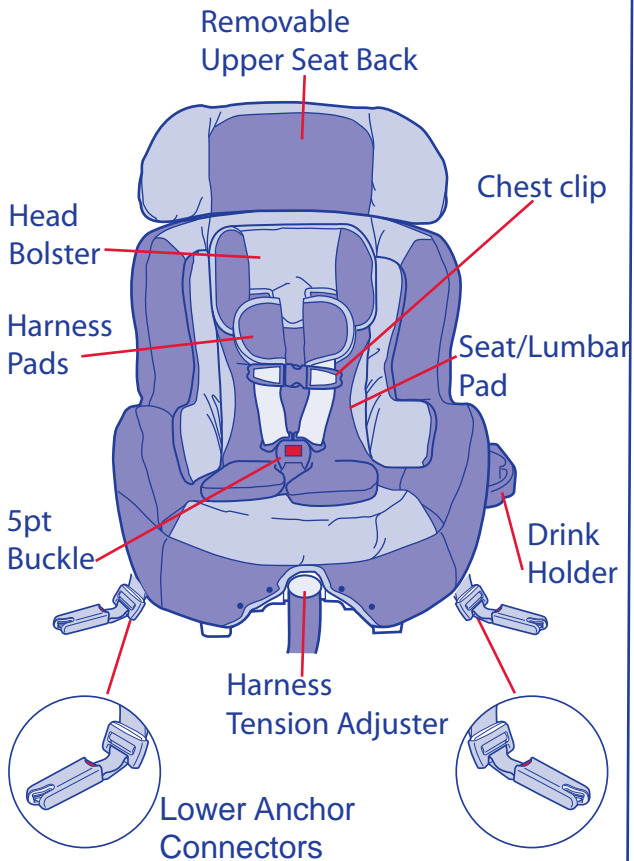

Section 5 - Convertible Seat Parts

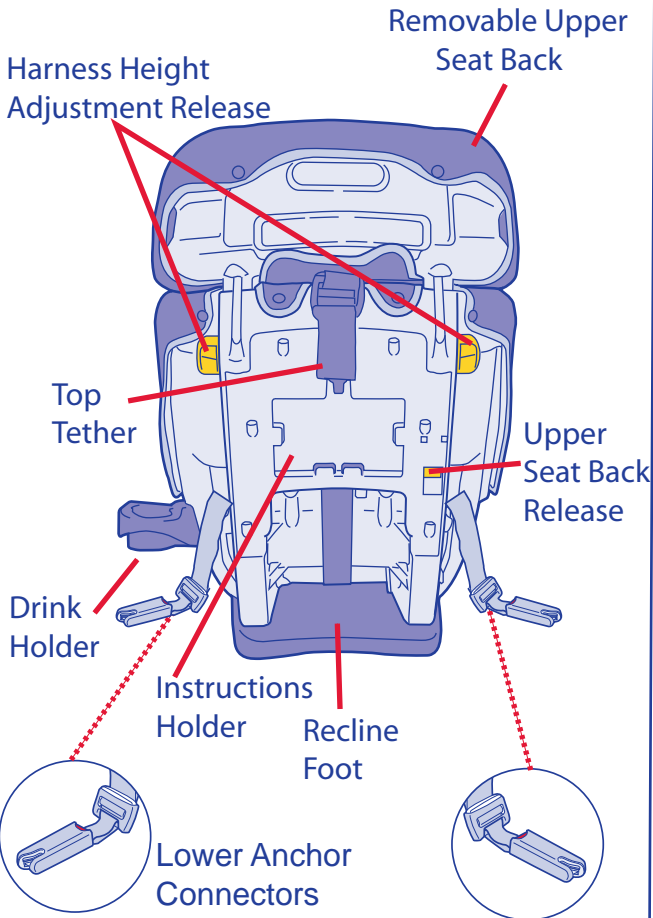

⚠ WARNING ⚠

DEATH or SERIOUS INJURY can occur

- Only use this Convertible Seat with the vehicle's seat belts or LATCH System.
- DO NOT use this Convertible Seat with vehicle seat belts mounted to the vehicle door or door frame.
- DO NOT use this Convertible Seat if it cannot be properly installed. Some child restraints will not fit some vehicle seating positions.
- NEVER use this Convertible Seat in any vehicle seating position equipped with an active air bag. Read your vehicle's owners manual to see how to turn off your airbag if you have no back seat or a child must ride in the front seats. For side airbags see page 12.
- DO NOT use this Convertible Seat in rear seat of a compact pickup truck. Severe head injury or death can occur.
- DO NOT Use this Convertible Seat in a vehicle with side facing seats or rear facing vehicle seats. See page 13
- NEVER attempt to install this Convertible Seat without the upper seat back installed in forward facing position.
- NEVER use this restraint in a forward facing position with the removable upper seatback removed.
- NEVER attach two LATCH lower anchors to the same LATCH attachment point.
- NEVER use both the LATCH lower anchors and the vehicle's seat belts at the same time.



DO NOT place rear-facing child seat on front seat with air bag. DEATH OR SERIOUS INJURY can occur.

The back seat is the safest place for children 12 and under.

NO coloque el asiento infantil para el automóvil orientado hacia atrás en el asiento delantero del vehículo que tenga una bolsa neumática de seguridad. El niño podría MORIR O SUFRIR LESIONES GRAVES. El asiento trasero es el lugar más seguro para los niños de 12 años o menores.



Section 6 - Selecting A Vehicle Seating Location

1. National Highway Traffic Safety Administration (NHTSA) alerts vehicle owners that, according to accident statistics, children under age 13 are safer when properly restrained in the rear seating positions rather than in front seating positions.
2. Refer to vehicle owner's manual for car seat installation instructions for your specific vehicle.
 - Use of Convertible Seats in a vehicle rear seat location.
 - LATCH anchor connector points maximum weight ratings
 - Never put Convertible Seats in a front seat location unless permitted by vehicle owner's manual.
 - For vehicles with air bags, refer to vehicle owner's manual for child restraint installation information.
 - If a vehicle front seat location with an air bag must be used, follow the vehicle manufacturer's instructions to disable air bags that could cause serious injury to child and move seat back as far as possible.

The First Years Policy Statement Use Of True Fit Convertible Seat Child Restraint In Conjunction With Side Airbags

To determine the types of side impact air bag(s) your vehicle may have for individual seating positions, please refer to your owner's manual. The First Years True Fit Convertible Seat child restraint may be used in any rear seating position equipped only with side impact airbags that are roof mounted with "curtain" type deployment. For all other vehicles with other types of side impact airbags, please refer to your specific vehicles owner's manual for appropriate use of child restraints, or call the automobile manufacturer for more information.

Section 6 - Selecting A Vehicle Seating Location

3. Vehicle Seats:

DO NOT use this Convertible Seat with the following vehicle seats:



Seats Which Face Sides Of Vehicle



Seats Which Face Rear Of Vehicle



Rear Seats Of Small Extended Cab Pickup Trucks

4. Vehicle Seat Belt Systems:

Use only the vehicle's lap and shoulder belt, lap belt or LATCH system when restraining this Convertible Seat.

Design and operation of vehicle seat belt systems vary from vehicle to vehicle and from seating location to seating location in the same vehicle. Not all vehicle seat belts can be used with a child restraint. Refer to the information in this section on the various types of vehicle seat belt systems.



Lap and Shoulder Belt

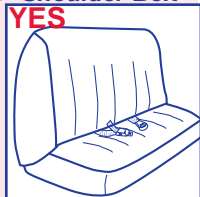

Lap Belt Only

Section 6 - Selecting A Vehicle Seating Location

4. Vehicle Seat Belt Systems:

DO NOT use this Convertible seat with the following vehicle seat belts.



*Passive Restraints
Motorized
Shoulder Belt*

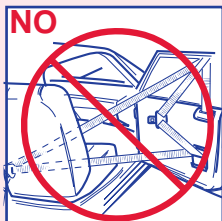

*Passive Restraints
Lap Or Shoulder
Belt Mounted On
Front Door*

5. LATCH Lower Anchor Points

Consult your automobile's owner's manual or manufacturer for location and availability of LATCH anchor points.

Lower
Anchor Point
Locations

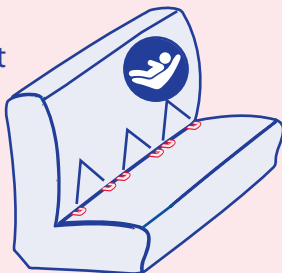

Section 6 - Selecting A Vehicle Seating Location

What is LATCH?

LATCH is a new system for attaching the child restraint to your vehicle seat. LATCH connects a child restraint to your automobile without using a seat belt. It is called Universal Anchorage System (UAS) in Canada or ISOFIX in Europe.

LATCH stands for **L**ower **A**nchor and **T**ethers for **C**hildren.

If your vehicle is equipped with **LATCH** lower anchor attachment points, the lower anchor attachment points may be visible at the seat crease. If not, the symbol below may be affixed near the seat crease to indicate the attachment points.



LATCH Lower Anchor symbol

Top Tether Locations are indicated by the following symbols.



LATCH Top Tether symbol

Consult your vehicle's owner's manual for your vehicle's exact LATCH locations, anchor identifications and usage requirements.

NOT all vehicles have the same locations or maximum weight requirements for LATCH!

Section 6 - Selecting A Vehicle Seating Location

LATCH - Top Tether Anchor Locations

Ceiling mount

Rear
Package Shelf

Pick up
Truck

Vehicle With
Reinforced Seats →

Floor
Mounts

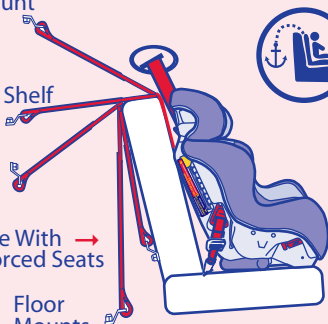

LATCH - Lower Anchor Attachment Points

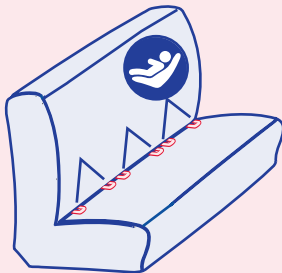

This child restraint is equipped with lower anchor and top tether connectors.

Section 6 - Selecting A Vehicle Seating Location

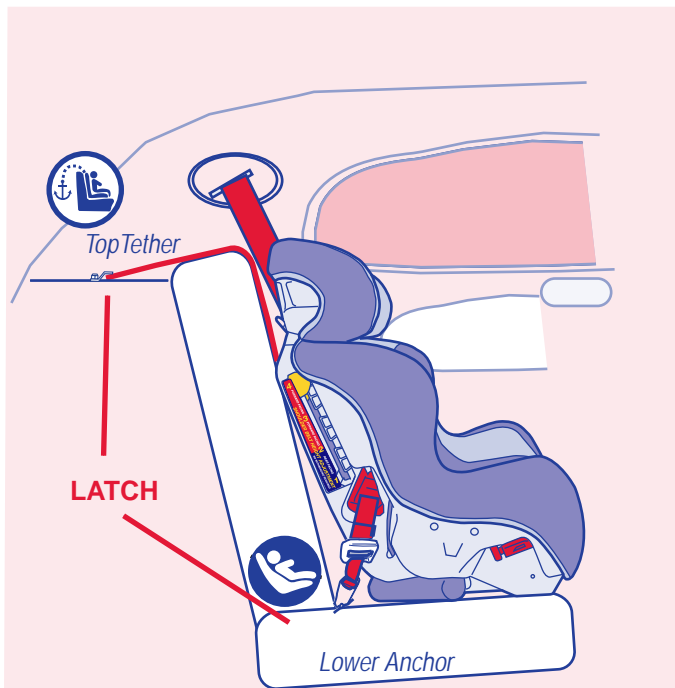

Maximum Child Weight for LATCH

Lower Anchor	48lbs (21kg)
Top Tether	48lbs (21kg)

Use the vehicle's seat belt for children weighing more than 48 lbs.(21kg) or refer to your automobile's owner's manual for the maximum weight allowances for LATCH installation.

▲ WARNING ▲
DEATH or SERIOUS INJURY can occur

- Use only in a rear facing position when using restraint with an infant weighing less than 22 Pounds. (9kg)
- Use only with children who weigh between 5 and 65 pounds (2,3 and 29 kg) and whose height is 50 inches (127 cm) or less. Rear Facing 5-22 pounds with the removable upper seatback removed. Rear facing 5-35 (2.3-15,9 kg) pounds with removable upper seatback installed. Forward facing 1 year and 23 pounds to 65 pounds(10,43-29kg).
- Snugly adjust the belts (Harness) provided with this child restraint around your child. Snug means you can not pinch webbing once buckled.
- Secure the top anchorage strap provided with this restraint.
- Secure this child restraint with the vehicle's child restraint Anchorage system (LATCH) if available or with a seat belt.
- Follow all instructions on this child restraint and in the written Instructions located on the back of the seat. Do not use without instructions. Call 1-888-899-2229 to obtain instructions.
- Register your child restraint with Learning Curve.
- **DO NOT** place this rear facing child seat in a front seat that has an active airbag.
- **NEVER** leave child unattended under any circumstance.

Section 7 - Installation and Use

7.1 - Forward Facing Installation with Seat Belt and Top Tether



Top Tether

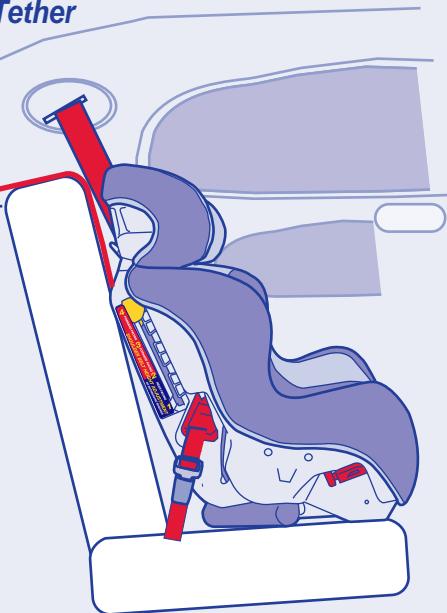

- 1 - Ensure vehicle is level.
- 2 - Place this restraint in a rear seating position.



Section 7 - Installation and Use

7.1 Forward Facing with Seat Belt and Tether Installation

- 3 Lift back flap and place harness to side.
- 4 Unlock and lower forward facing lock off.
- 5 Route auto belt through forward facing belt path.
- 6 Put weight in seat with hand to compress the automobile seat cushion.
- 7 With weight still in seat, insert the buckle tongue into the buckle and adjust seat belt as tight as possible. Pull up on buckle tongue to ensure the buckle is secure.
- 8 Raise forward lockoff over the seat belt.

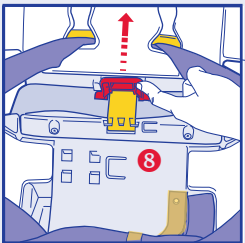
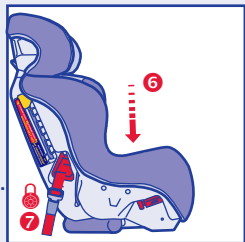
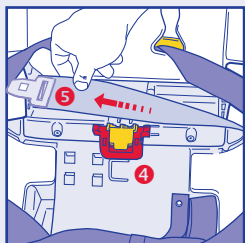

Section 7 - Installation and Use

7.1 Forward Facing with Seat Belt and Top Tether Installation

- 8 Cont.**-Engage the red lock tab and press down to lock.

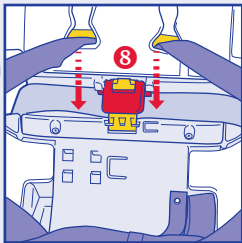

- 9** Lower flap and secure hook and loop fasteners.



- 10** Attach Top Tether to a designated anchor point.

- 11** Pull Top Tether strap until webbing strap is snug.

Your automobile's owner's manual will give the anchor locations and maximum weight of the restraint's occupant for LATCH connections.

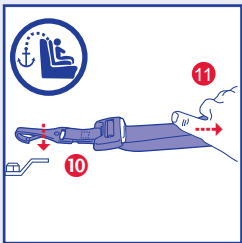

- 12** Check for movement of the restraint at the safety belt path. The restraint should not move more than 1 inch in any direction.

If the restraint moves more than 1 inch repeat all steps until all safety steps are met.

7.2 **LATCH** - Forward Facing Installation with Lower Anchor and Top Tether

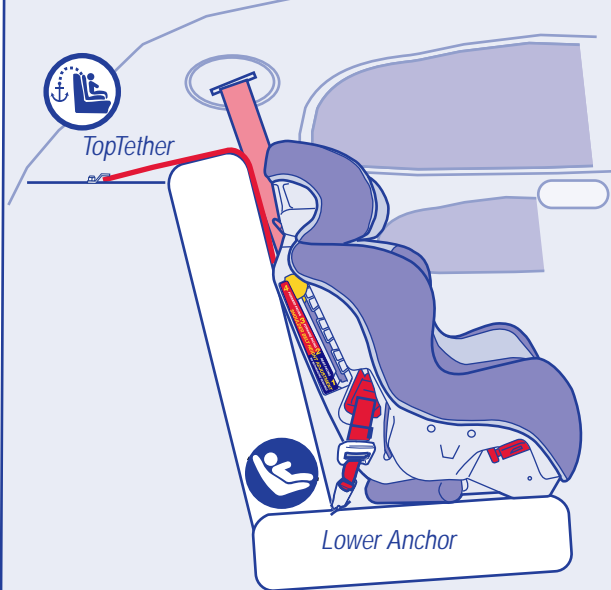

- 1 Ensure vehicle is level.
- 2 Place this restraint in a rear seating position designated as lower anchor compatible. Refer to your automobile's owner's manual for **LATCH** locations.

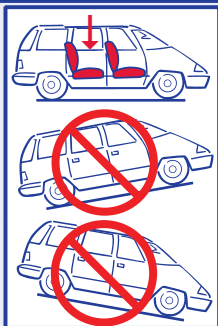

Section 7 - Installation and Use

7.2 **LATCH** - Forward Facing Lower Anchor with Top Tether

3 Lift back flap and place harness to side.



4 Unlock and lower forward facing lock off.

5 Route lower anchors through forward facing belt path.

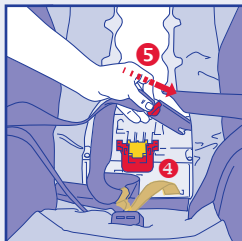

6 Press down on seat with hand to compress the automobile seat cushion.

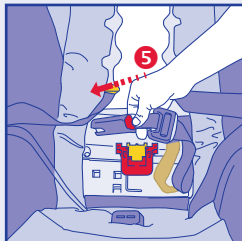

7 With weight in seat, insert the lower anchor connector on to the vehicle connector anchor point. Tighten the lower anchor connector by pulling up on the webbing end. Pull up on the lower anchor connector to ensure the lower anchor is securely fastened.

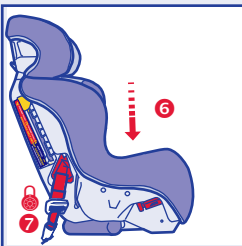

Section 7 - Installation and Use

7.2 LATCH - Forward Facing Lower Anchor with Top Tether

- 8 Raise forward lock off over the LATCH belt. Engage the red lock tab and press down to lock.

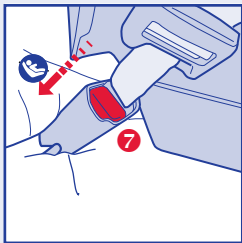

- 9 Lower flap and secure hook and loop fasteners.

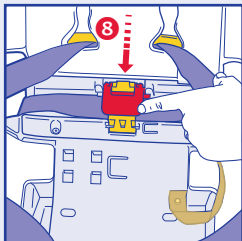

- 10 Attach Top Tether connector to a designated vehicle anchor point.

- 11 Pull Top Tether until webbing strap is snug.
Your automobile's owner's manual will give the anchor locations and maximum weight of the restraint's occupant for LATCH connections.



- 12 Check for movement of the restraint at the safety belt path. The restraint should not move more than 1 inch in any direction.

If the restraint moves more than 1 inch, repeat all safety steps until all steps are met.

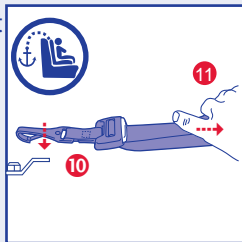

7.3 Rear Facing Installation with Seat Belt.

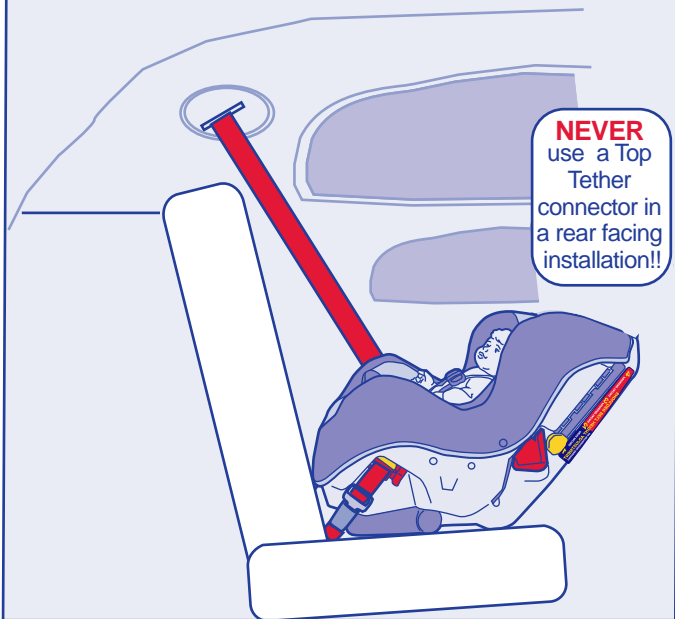

The True Fit, in a Rear Facing installation was designed with a removable upper seatback to allow for a proper installation when the upper seatback comes in contact with the front seat. If the upper seatback comes in contact with the front seat and prevents a 45 degree installation, remove the upper seatback and install the True Fit at 45 degrees per the instructions in this section. To remove the upper seatback refer to section 7.17 and read all **WARNINGS**. Reinstall the upper seat back when child reaches 22 lbs. Keep child rear facing as long as possible

If you have any question regarding the use of the upper seat back or any other questions please contact the First Years staff at **1-888-899-2229**.

7.3 Rear Facing Installation with Seat Belt.

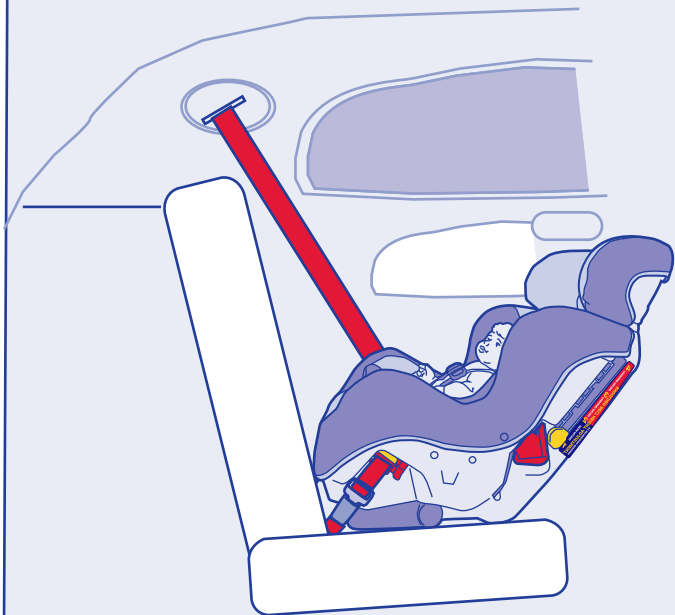

- 1 Ensure vehicle is level.
 - 2 Move recline foot to the reclined position and place this restraint in a rear seating position.
- Note:** If needed a towel or pool noodle can be used for extra elevation and angle adjustment.



Section 7 - Installation and Use

7.3 Rear Facing installation with Seat Belt .

- 3 Unsnap the 4 front snaps and the 2 side snaps. Lift and fold back padding.

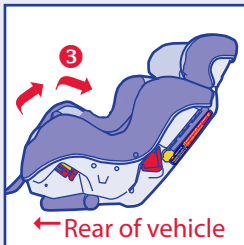

- 4 Rotate red rear facing lock off toward the center of the restraint.

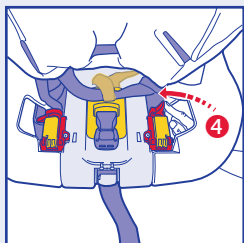

- 5 Lift the yellow arm away from lock off.

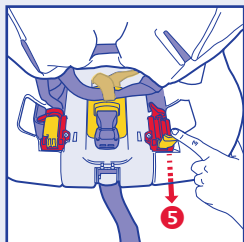

- 6 Rotate red rear facing lock off toward the center of the restraint.

- 7 Lift the yellow arm away from lock off.

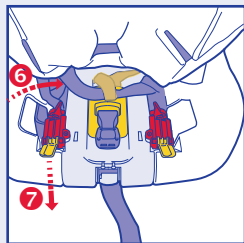

7.3 Rear Facing Installation with Seat Belt .

- 8 Route seat belt through the rear facing safety belt path.
- 9 Press down on seat with hand to compress the automobile seat cushion.
- 10 With weight still in seat, insert the seat buckle tongue into the buckle and pull seat belt tight as possible. Pull up on buckle tongue to ensure the buckle is secure.
- 11 Press yellow arm into place and hold.
- 12 Rotate red lock to the locked position. You will feel the red lock, snap into position. *Repeat other side.*
- 13 Ensure the angle indicator line is level with the ground to keep the child's airway open.
- 14 Check for movement of the restraint at the safety belt path. The restraint should not move more than 1 inch in any direction. **If the restraint moves more than 1 inch, repeat all steps until all safety steps are met.**
- 15 Fold pad down and fasten all snaps.

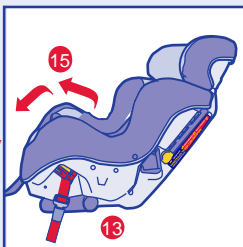
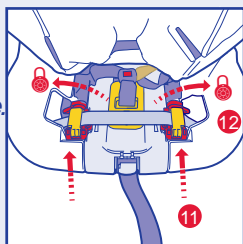
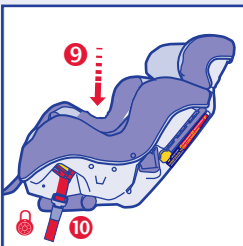
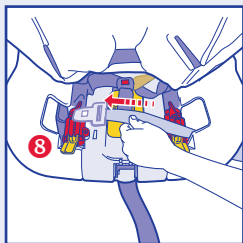

7.4 Rear Facing Installation with Lower Anchor

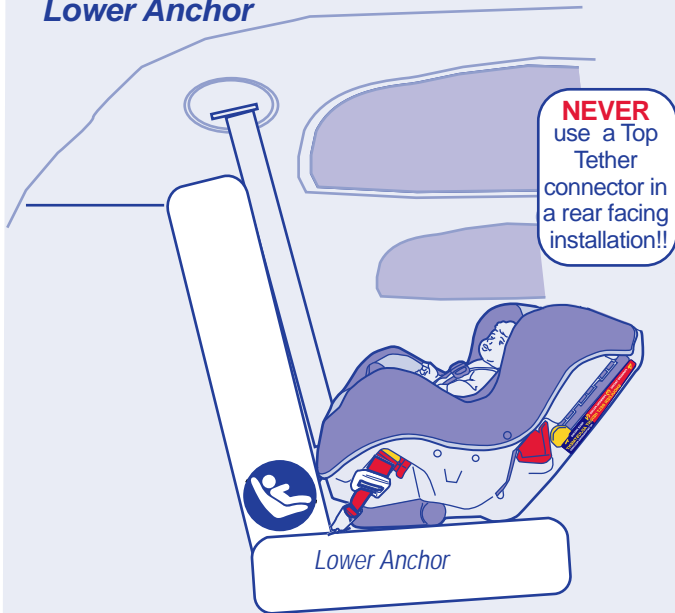

The True Fit, in a Rear Facing installation, was designed with a removable upper seatback to allow for a proper installation when the upper seatback comes in contact with the front seat. If the upper seatback comes in contact with the front seat and prevents a 45 degree installation, remove the upper seatback and install the True Fit at 45 degrees per the instructions in this section. To remove the upper seatback refer to section 7.17 and read all **WARNINGS**. Reinstall the upper seat back when child reaches 22 lbs. Keep child in a rear facing position as long as possible

If you have any question regarding the use of the upper seat back or any other questions please contact the First Years staff at

1-888-899-2229

7.4 Rear Facing Installation with Lower Anchor

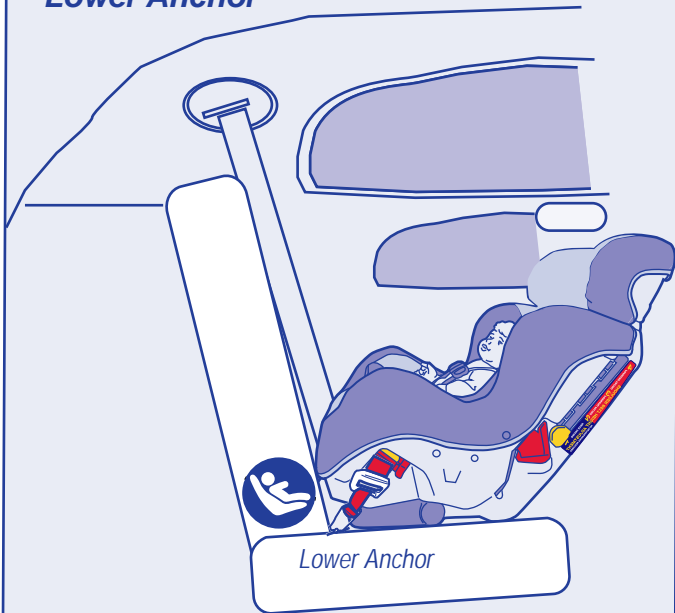

① Ensure vehicle is level.

② Move recline foot to the reclined position and place this restraint in a rear seating position designated as lower anchor compatible. Refer to your automobile's owner's manual for **LATCH** locations.



Section 7 - Installation and Use

7.4 - Rear Facing Installation w/ Lower Anchor

- 3** Unsnap the 4 front snaps and the 2 side snaps. Lift and fold back padding.

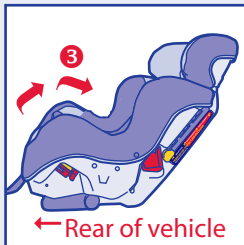

- 4** Rotate red rear facing lock off, lock toward the center of the restraint.

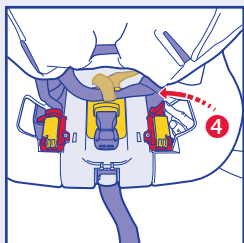

- 5** Lift the yellow arm away from lock off.

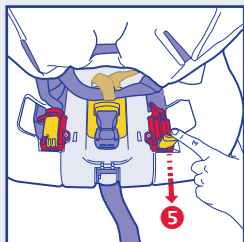

- 6** Rotate red rear facing lock off, lock toward the center of the restraint.

- 7** Lift the yellow arm away from lock off.

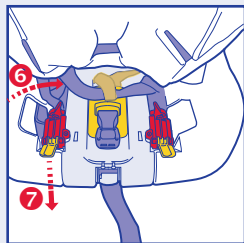

Section 7 - Installation and Use

7.4 - Rear Facing Installation w/ Lower Anchor.

- 8 Route lower anchor connector connectors through rear facing safety belt path.

NOTE: Remove any twist in webbing to ensure the webbing lies flat for securing the restraint to the vehicle.

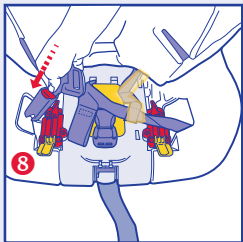
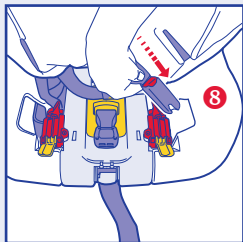

- 9 Press down on seat with hand to compress the automobile seat cushion.

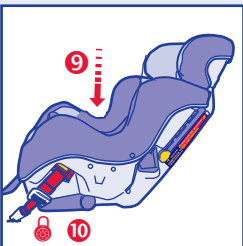

- 10 With weight in seat, insert the lower anchor connector onto the vehicle connector anchor point. Tighten the lower anchor connector by pulling up on the webbing end. Pull up on the lower anchor connector to ensure the lower anchor is securely fastened.

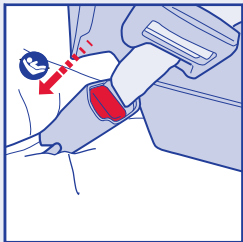

Section 7 - Installation and Use

7.4 - Rear Facing Installation w/ Lower Anchor

- 11 Press yellow arm into place and hold.
- 12 Rotate red lock to the locked position. You will feel the red lock, snap into position. Repeat other side.
- 13 Ensure the angle indicator line is level with the ground to keep the child's airway open.
- 14 Check for movement of the restraint at the safety belt path. The restraint should not move more than 1 inch in any direction.

If the restraint moves more than 1 inch, repeat all steps until all safety steps are met.

- 15 Fold pad down and fasten all snaps.

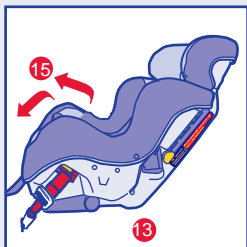
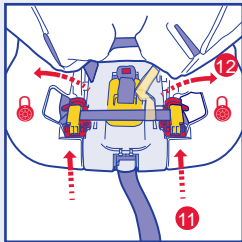

7.5 - Aircraft Use

- 1 Follow the seat belt installation for use in an Aircraft.
- 2 Consult your airline for requirements to use this restraint.

7.6 Child Placement in Restraint

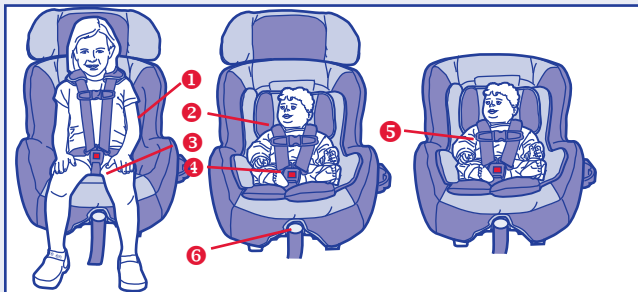

- 1 Place child in the restraint with the child's back flat against the back of the restraint and the child's bottom touching the seat.
- 2 Place harness straps over the child's shoulders. Note: Check the height of the harness straps at the child's shoulders.
- 3 Place 5 pt. crotch buckle strap at crotch but not under.
- 4 Insert the silver buckle tongues into the buckle. Note: Pull up and test buckle tongues to be sure they are secure.
- 5 Place chest clip at arm pit level. Insert chest clip tabs and press together. Pull outward on chest clip's ends to be sure it is secure.
- 6 Pull on harness adjuster to tighten harness straps. *A snug strap should not allow any slack. It lies in a relatively straight line without sagging. It does not press on to the child's flesh or push the child's body into an unnatural position.*

7.7 Selecting the Harness Height Location

Rear Facing Harness Strap Height- Harness straps should be located in the nearest position at or below the shoulder.

The True Fit has been safety tested with the **1** height insert and head pillows that are included with this restraint. The height insert is needed until the child's shoulder is at or above position 1.

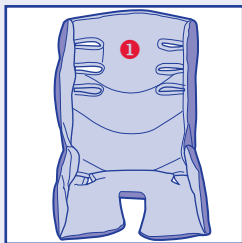
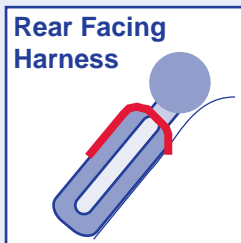

Forward Facing Harness Strap Height- Harness strap should be located in the slot at or **slightly** above the child's shoulder

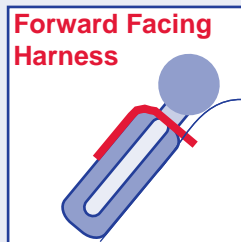

7.8 Shoulder Height Adjustment

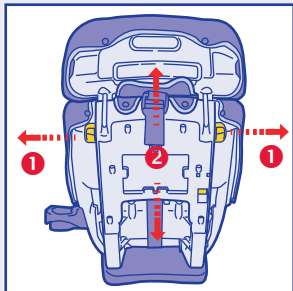
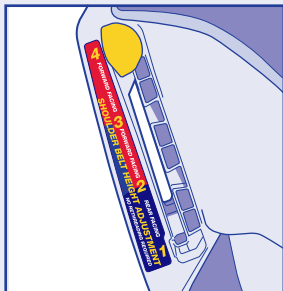

Shoulder Height Positions

<i>Facing Direction</i>	<i>Position</i>
Rear	1, 2 & 3
Forward	2, 3 & 4

Height Adjustment

- 1 Pull on yellow release handles
- 2 Raise or lower to the appropriate position.

7.9 Tether Storage

- 1 Store top tether on back of seat when not used in a rear facing installation.

Use top tether in all forward facing installations

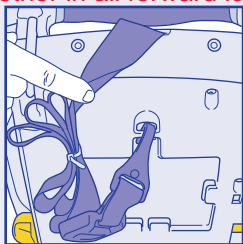

7.10 - 5 Point Buckle

To Unlock the 5 Point Buckle

- 1 Press the red button until 5 point buckle releases.
- 2 Pull buckle tongues up to remove.

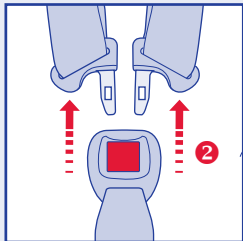
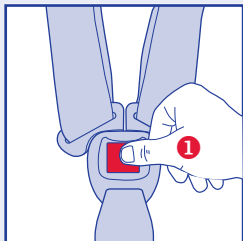

To Lock the 5 Point Buckle

- 1 Align and insert the silver buckle tongues one at a time until the tongues lock in place.
- Note:** Pull up on buckle tongues to test and ensure buckle is secure.

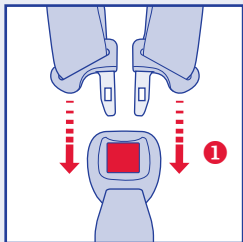

7.11 Chest Clip

To Unlock the Chest Clip

- 1 Squeeze center locking tabs.
- 2 Pull Chest clip apart.

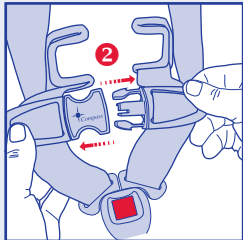
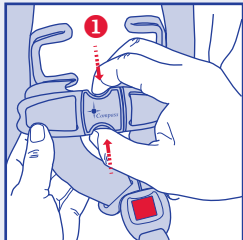

To Lock the Chest Clip

- 1 Align locking tabs and press Chest Clip together until tabs snap into place.

Note: Gently pull on Chest Clip to ensure Chest Clip is secure.

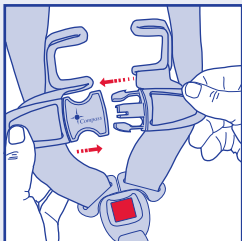

7.12 Adjusting Harness Tension

To Tighten Harness System Tension

- 1 Pull on the harness tension adjuster to tighten harness straps.

Tension Tip!

A snug strap should not allow any slack. It lies in a relatively straight line with out sagging. It does not press on to the child's flesh or push the child's body into an unnatural position.

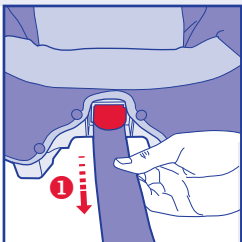

To Loosen Harness System Tension

- 1 Lift the metal tab and
- 2 gently pull on the harness strap over the child's shoulder.

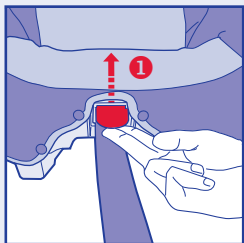

7.13 2 Position Crotch Buckle Adjustment

To change position

- 1 Press the crotch buckle plunger down with fingers and move position.

Fit Note: The crotch buckle should be at the crotch but not under.

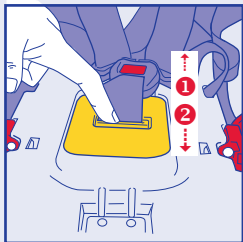

1-Rear Position.

2-Forward Position.

Note: For children weighing more than 50lbs use the forward position

7.14 Seat Insert Use

The True Fit has been safety tested with the **1** height insert and head pillows that are included with this restraint. The height insert is needed until the the child's shoulder is at or above position 1.

DO NOT use this height insert for infants/children above 22lbs (10kg) or in a forward facing position.

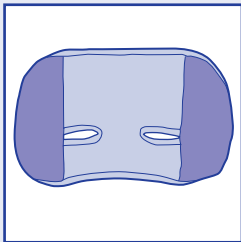
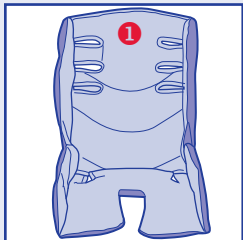

7.15 Harness Length Adjustment

To Adjust Harness Length

- 1 Unhook the harness straps from the metal plate and move to the desired adjustment.
- 2 Ensure the harness strap ends are **fully hooked** on the metal plate. Both side must look alike!!

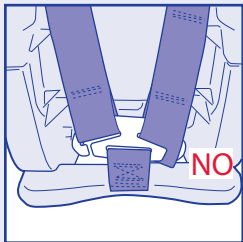
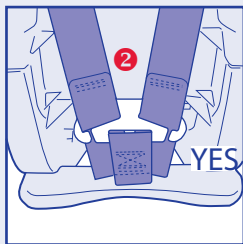
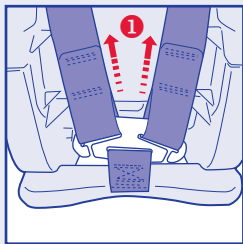

7.16 Recline Foot Adjustment

The Recline foot has two positions.

- 1 Forward Facing Upright
- 2 Rear Facing Recline

To change to position of the rear facing recline foot, grasp the recline foot and move toward the desired location.

Always adjust the recline foot **upright** to the upright position when forward facing.

Always adjust the recline foot to the **recline** position when rear facing. Angling the restraint to keeps the baby's head back and airway open. Note: If needed a towel or pool noodle can used for extra elevation and angle adjustment.

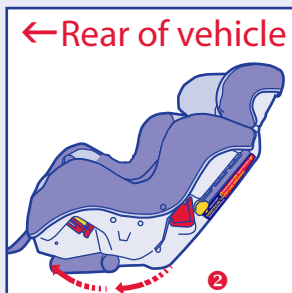
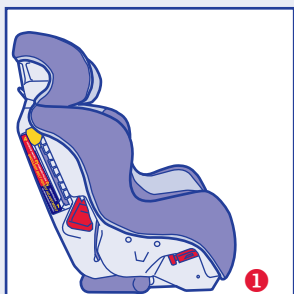

7.17 Upper Seatback Removal

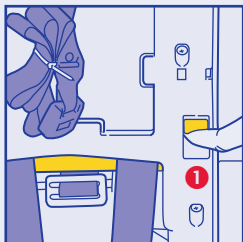
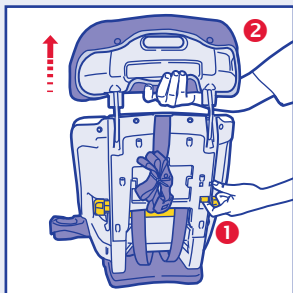

Remove the upper seat back by lifting the yellow release tab **1** and pulling up on the upper seat back **2**.

NOTE: DO NOT store the upper seat back in the passenger compartment. Store the upper seat back in a secure location like your trunk or garage.

⚠ WARNING ⚠

DEATH or SERIOUS INJURY can occur

The upper seat back must be installed:

When the child weighs more than 22 lbs

or

The top of the child's head is within 1 inch of the top of the restraint

or

The restraint is forward facing.

7.18 Upper Seatback Installation



Installation

Align the upper seat back rods and push rods into the openings until you hear or feel a click. Pull up on the upper seat back to ensure the removeable upper seat back is locked in position.

⚠ WARNING ⚠

DEATH or SERIOUS INJURY can occur

The upper seat back must be installed:

When the child weighs more than 22 lbs

or

The top of the child's head is within 1 inch of the top of the restraint.

or

The restraint is forward facing.

7.19 Pad Removal & Laundering

Pad Removal

- 1 Unfasten the 4 elastic loops located on the bottom of the True Fit.
- 2 Unfasten the 10 snaps located on the edge of the pad.
- 3 Lift the seatback flap.
- 4 Remove the upper seat back.
- 5 Remove the pad to launder.
- 6 Upper seat pad. Unfasten 4 snaps and remove.

To Launder

Hand wash in cool water with mild detergent and hang to dry.

DO NOT Machine wash or dry in dryer.

Section 7 - Installation and Use

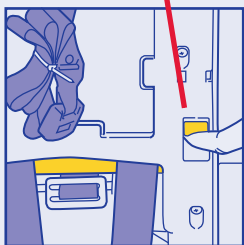
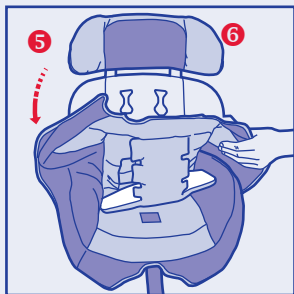
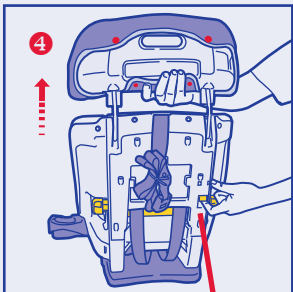
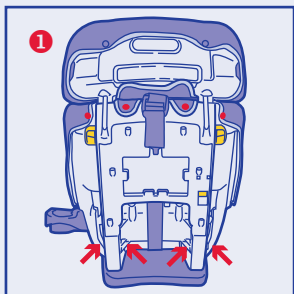

7.20 Installation Pictograms

Rear Facing

Lap Belt



Lap / Shoulder



Lower Anchor



Rear Facing

Lap Belt



Lap / Shoulder



Lower Anchor



Forward Facing

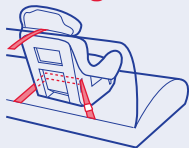

Lap Belt/
Top Tether

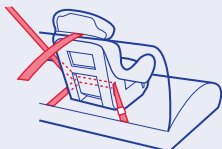

Lap / Shoulder
w/ Top Tether

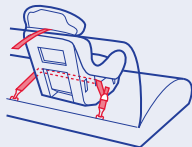

LATCH
Lower Anchor
w/ Top Tether

Section 8 - Safety Checklist/Safe Practices

Safe Practices

For assistance with installation or use, contact one of the following sources:

- Learning Curve at:
Phone: 1-888-899-2229
Email: CS@learningcurve.com
- A certified Child Passenger Safety (CPS) Technician in your area. To locate a CPS Technician in your area, log onto www.nhtsa.dot.gov and select "Child Passenger Safety" and then select "Technician Contact Locator".

Or attend a car seat check-up event. For car seat check-up event location and timing:

- Log onto www.nhtsa.dot.gov and select "Child Seat Inspections".
- Log onto www.seatcheck.org.
- Call 1-866-SEAT CHECK (1-866-732-8243).

- * **EVERYONE rides buckled up or the vehicle DOES NOT GO! Make NO EXCEPTIONS** for adults or children!
 - If someone unbuckles, the vehicle **STOPS!** Being firm and consistent will result in fewer discipline problems as children grow older. An unrestrained person can be thrown into and injure other passengers.
 - **NEVER** try to tend to a crying child's needs while driving. Never take a child out of a child restraint for comforting while the vehicle is moving.
- * Put heavy or sharp items in the trunk. Loose items can be deadly in a crash.
- * If you need to use a blanket in cold weather, put the child in the restraint and cover both with the blanket.

Section 8 - Safety Checklist/Safe Practices

Safety Checklist

- Did you read and understand these instructions and labels on the convertible car seat?
- Is the child the proper weight and height for the seat in the rear facing position?
- If the child is in the rear facing position, are the shoulder straps at or below the child's shoulders?
- Have you checked the angle indicator line to be horizontal in the rear facing position?
- If the child is over 22 lbs, have you reinstalled the head rest?.
- If the top of the child's head is within 1" of the top of the head rest and the seat is rear facing, have you reinstalled the upper seat back?
- If the seat is forward facing, have you reinstalled the upper seat back?
- Is the child the proper weight and height for the seat in the forward facing position?
- If the child is in the forward facing position, are the shoulder straps at or above the child's shoulders?
- Did you pull the harness adjuster tight? You should not be able to pinch the harness if the harness is properly tightened.
- Is the child restraint buckled in the automobile with either the LATCH system or the auto safety belt system?
- Current date is not after "Do Not use After" date on bottom of convertible ?
- Has the airbag been deactivated in a vehicle with a front only seat?

Section 9 - Additional Information

Certification:

This child restraint system conforms to all applicable Federal Motor Vehicle Safety Standards for use in motor vehicles.

This Convertible Seat is certified for use in motor vehicles.

Aircraft Use:

This Restraint is Certified for Aircraft Use.

Vehicle Seat Protection:

Protect vehicle seat. Use a thin car seat mat, thin towel, or thin blanket under the Convertible Seat.

Instruction Manual Storage:

Store instruction manual in pocket on the back of the Convertible Seat.

Convertible Seat Useful Life:

DO NOT use this Convertible Seat after date on bottom of seat Parts may be missing, damaged, or the Convertible Seat may have been in a crash.

Registration Information:

“Child restraints (car seats) could be recalled for safety reasons. You must register this restraint to be reached in a recall. Send your name, address, and the restraint’s model number and manufacturing date to:

Learning Curve Brands

Attn: Consumer Services

2021 9th St. SE

Dyersville, IA 52040

or call 1-888-899-2229 or log onto www.learningcurve.com

For recall information, call the U.S. Government's Vehicle Safety Hotline at 1-888-327-4236, (TTY 1-800-424-9153) or go to <http://NHTSA.gov>.”

Section 10 - Care and Cleaning

Removing Seat Pad:

- Follow directions on page 45.

Cleaning Seat Pad, Head Bolster and Height Insert:

- Hand wash in cool water and mild soap.
- Air dry.

Cleaning Shell:

- Wipe with mild solution of soap and water. Avoid wetting labels.
- Rinse with clean water.
- Never use "household" detergents or solvents.

Reattach Seat Pad:

- Follow directions on page 45 to reattach pad.

Section 11 - Replacement Parts

We know pads get worn or damaged. Some companies charge outrageous prices when their parts wear out. At *The First Years*, we will sell you replacement parts at or near our cost plus what it costs us to handle and ship them. They are still expensive, but we promise they are fair prices. **Of course, replacement instructions are always free.** Please call for current prices on other items.

True Fit Notes

Blank page for notes.

Keep this instruction manual for future use.
Store in pocket on back of the Convertible Seat.



Learning Curve Brands
Attn: Consumer Services
2021 9th St. SE
Dyersville, IA 52040

or call 1-888-899-2229

or log onto www.learningcurve.com