

# Service Manual

**Supplement**

Compact Disc Changer

Compact Disc Changer

**SL-PD349**  
**SL-PD665**  
**SL-PD687**  
**SL-PD887**

■ This document is supplementary to the following Service Manuals:

Model No.	Area Code	Order No.
SL-PD349	(P)	AD9404110A1
SL-PD665	(PP)	AD9401023A1
SL-PD687	(E) (EB) (EG) (GC) (GN)	AD9502043C8
SL-PD887	(E) (EB) (EG)	AD9502066A2
	(GC) (GN)	AD9502067A3

**Colour (K) ... Black Type**

**Areas**

- P ..... U.S.A.
- PP ..... U.S.A. and Canada.
- E ..... Europe.
- EB ..... Great Britain.
- EG ..... Germany and Italy.
- GC ..... Asia, Latin America, Middle Near East and Africa.
- GN ..... Oceania.

■ **Purpose**

Please be informed of that the "Traverse Deck (Ass'y)" and "CD Servo P.C.B." of the CD unit have been changed on production.

■ **Applicable Serial Number Suffix**

Model No.	SL-PD349	SL-PD665	SL-PD687	SL-PD887
Serial No. Suffix	from "K" onward	from "I" onward	from "F" onward	from "F" onward

■ **How to distinguish in CD unit**

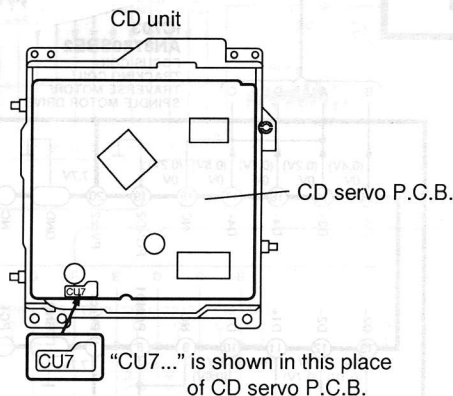

■ **Interchangeability**

The "NEW" Traverse Deck (Ass'y) (RAE0152Z) and the "FORMER" Traverse Deck (Ass'y) are interchangeable. Even if the CD unit has the former servo P.C.B., only the traverse deck is changeable to the new one.

**⚠ WARNING**

This service information is designed for experienced repair technicians only and is not designed for use by the general public. It does not contain warnings or cautions to advise non-technical individuals of potential dangers in attempting to service a product. Products powered by electricity should be serviced or repaired only by experienced professional technicians. Any attempt to service or repair the product or products dealt with in this service information by anyone else could result in serious injury or death.

# Schematic Diagram (New CD Unit)

## A CD SERVO CIRCUIT

### OPTICAL PICKUP CIRCUIT

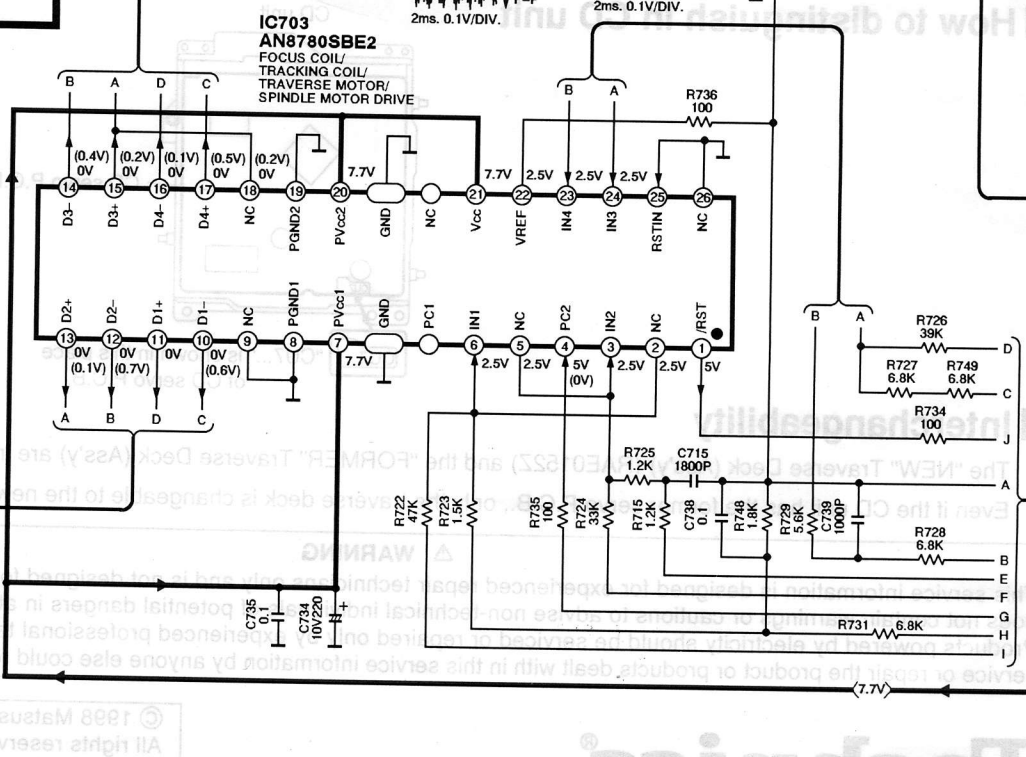
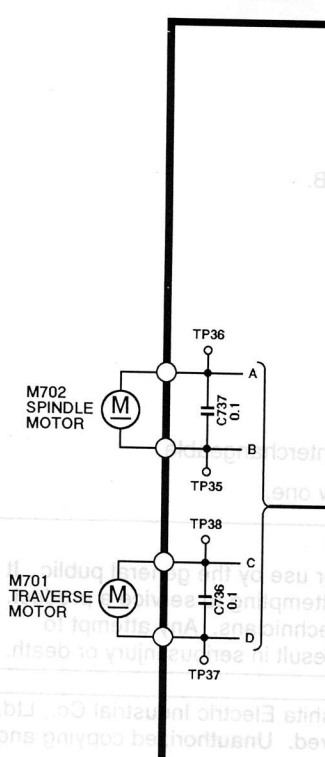
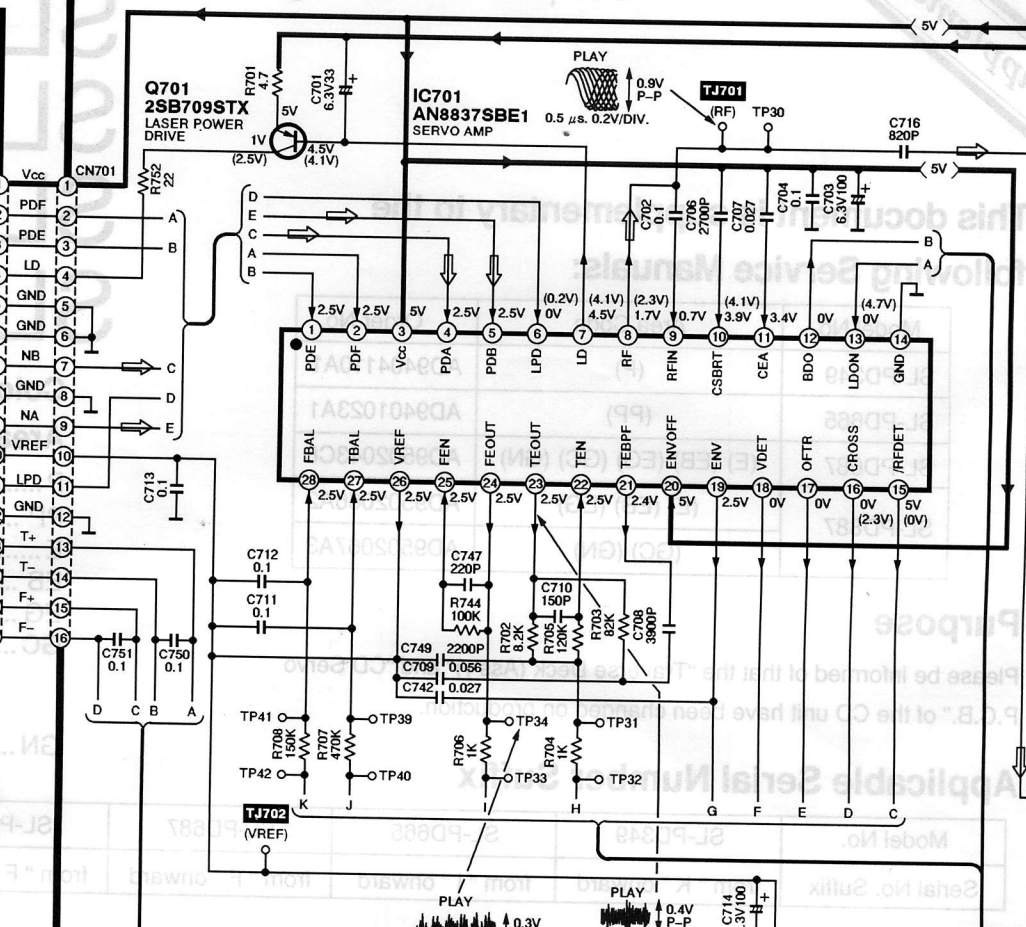
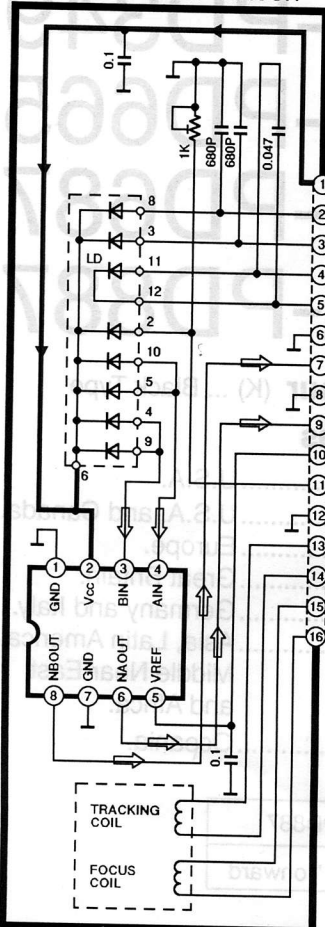

Note: ● → : CD signal line ● → : Positive voltage lines

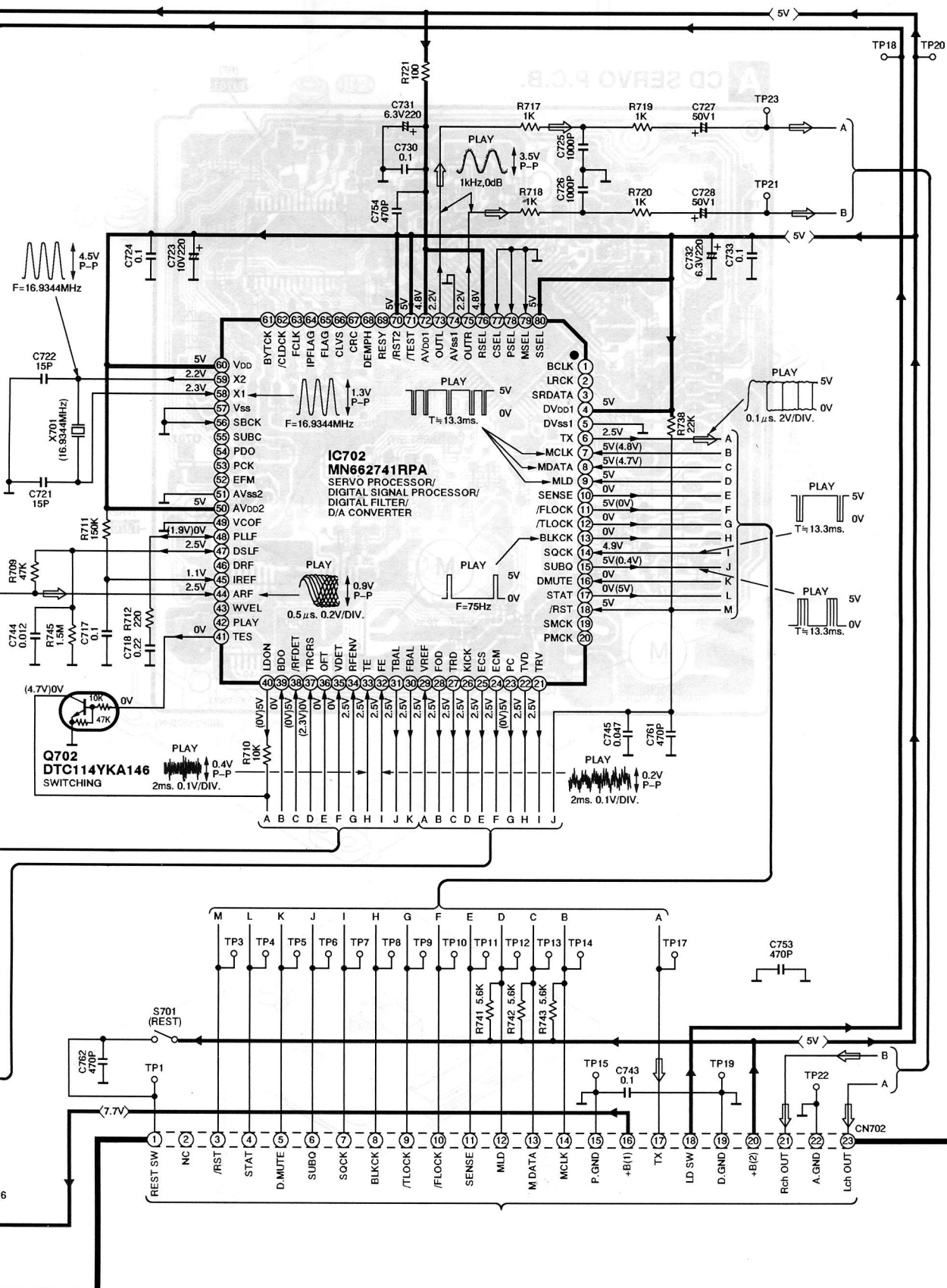

# Printed Circuit Board Diagram (New CD Unit)

Note: This printed circuit board diagram may be modified at any time with the development of new technology.

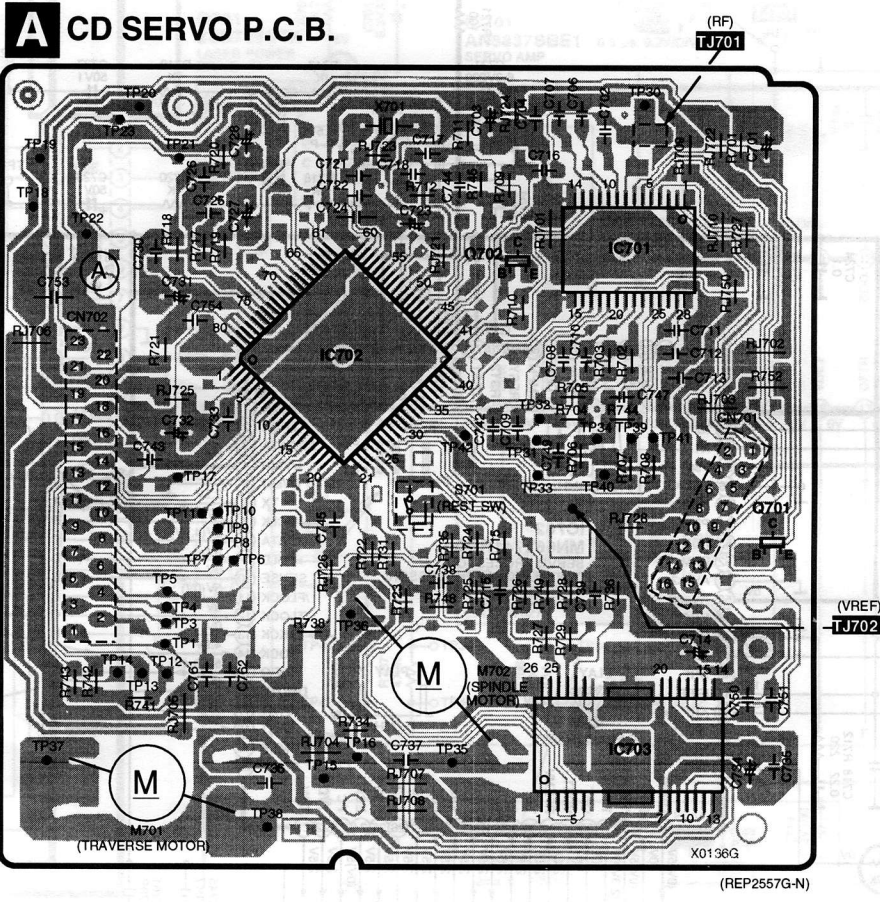

■ CD Unit Parts Location (New CD Unit)

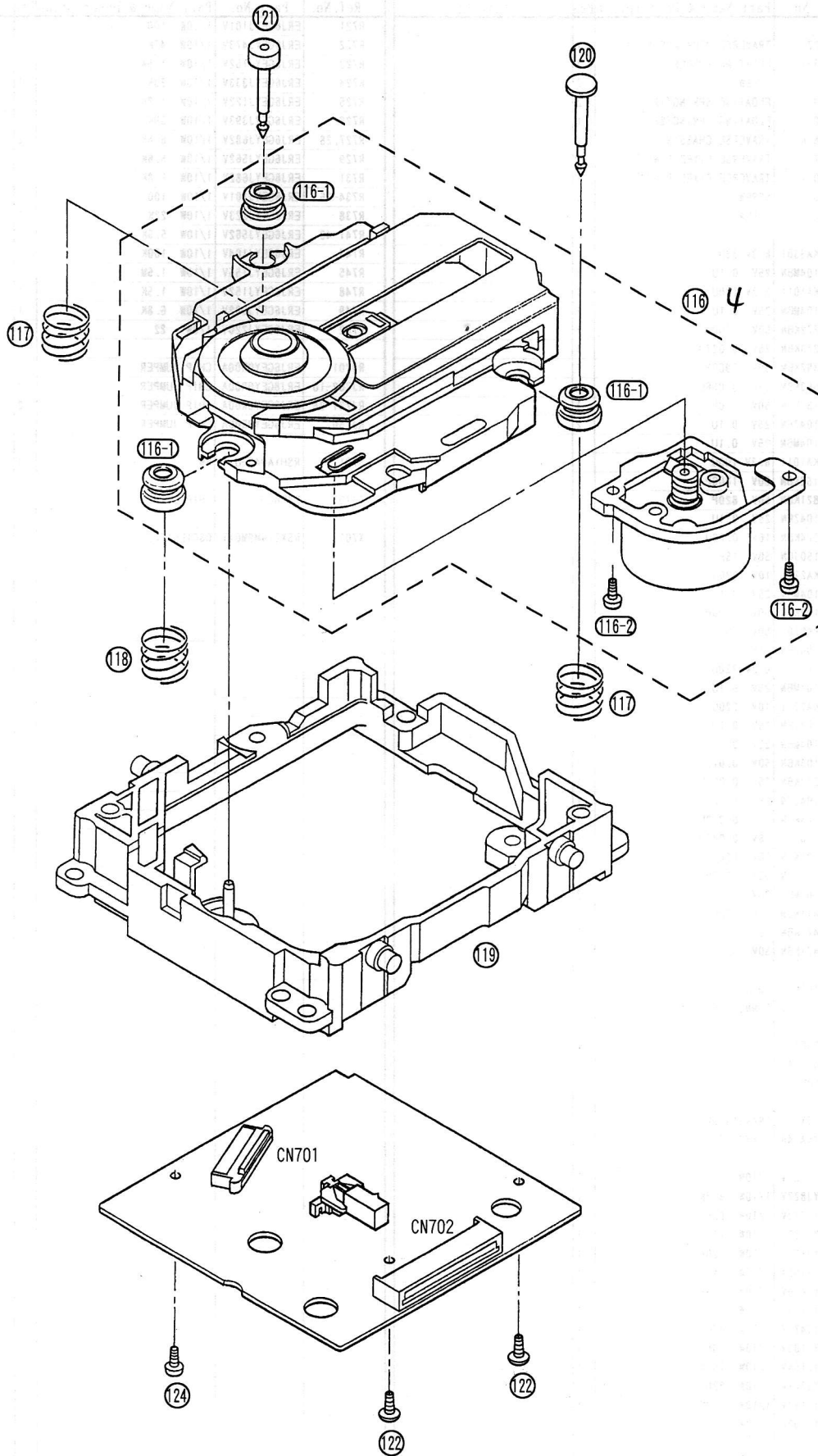

# Replacement Parts List (New CD Unit)

Ref.No.	Part No.	Part Name & Description	Pcs	Remarks	Ref.No.	Part No.	Part Name & Description	Pcs	Remarks
△ 116	RAE0152Z	TRAVERSE DECK ASS'Y	1		R721	ERJ6GEYJ101V	1/10W 100	1	
116-1	SHGD113-1	FLOATING RUBBER	3		R722	ERJ6GEYJ473V	1/10W 47K	1	
116-2	SNSD38	SCREW	2		R723	ERJ6GEYJ152V	1/10W 1.5K	1	
117	RME0109	FLOATING SPRING(1)	2		R724	ERJ6GEYJ333V	1/10W 33K	1	
118	RME0142	FLOATING SPRING(2)	1		R725	ERJ6GEYJ122V	1/10W 1.2K	1	
119	RMR0698-K	TRAVERSE CHASSIS	1		R726	ERJ6GEYJ393V	1/10W 39K	1	
120	RMS0627	TRAVERSE FIXED PIN(1)	1		R727, 28	ERJ6GEYJ682V	1/10W 6.8K	2	
121	RMS0350-1	TRAVERSE FIXED PIN(2)	1		R729	ERJ6GEYJ562V	1/10W 5.6K	1	
122	XTV2+6G	SCREW	2		R731	ERJ6GEYJ682V	1/10W 6.8K	1	
124	XTN2+6G	SCREW	1		R734-36	ERJ6GEYJ101V	1/10W 100	3	
					R738	ERJ6GEYJ223V	1/10W 22K	1	
C701	ECEA0JKA3301	6.3V 33U	1		R741-43	ERJ6GEYJ562V	1/10W 5.6K	3	
C702	ECUZNE104MBN	25V 0.1U	1		R744	ERJ6GEYJ104V	1/10W 100K	1	
C703	ECEA0JKA1011	6.3V 100U	1		R745	ERJ6GEYJ155V	1/10W 1.5M	1	
C704	ECUZNE104MBN	25V 0.1U	1		R748	ERJ6GEYJ152V	1/10W 1.5K	1	
C706	ECUV1H272KBN	50V 2700P	1		R749	ERJ6GEYJ682V	1/10W 6.8K	1	
C707	ECUV1E273KBN	25V 0.027U	1		R752	ERJ8GEYJ220V	1/8W 22	1	
C708	ECUV1H392KBN	50V 3900P	1						
C709	ECUV1E563KBN	25V 0.056U	1		RJ701	ERJ6GEYOR00A	CHIP JUMPER	1	
C710	ECUV1H151KCN	50V 150P	1		RJ702-10	ERJ8GEYOR00A	CHIP JUMPER	9	
C711, 12	ECUWNE104ZFN	25V 0.1U	2		RJ721-28	ERJ6GEYOR00A	CHIP JUMPER	8	
C713	ECUZNE104MBN	25V 0.1U	1		RJ750	ERJ6GEYOR00A	CHIP JUMPER	1	
C714	ECEA0JKA1011	6.3V 100U	1						
C715	ECUV1H182KBN	50V 1800P	1		S701	RSH1A043-U	SW	1	
C716	ECUV1H821KBN	50V 820P	1						
C717	ECUWNE104ZFN	25V 0.1U	1		TJ701	EYF8CU	CHIP CLIP	1	
C718	ECUVNC224KBN	16V 0.22U	1						
C721, 22	ECUV1H150JCN	50V 15P	2		X701	RSX216M9M01T	OSCILLATOR	1	
C723	ECEA1AKA2211	10V 220U	1						
C724	ECUZNE104MBN	25V 0.1U	1						
C725, 26	ECUE1H102KBN	50V 1000P	2						
C727, 28	ECEA1HPK0101	50V 1U	2						
C730	ECUWNE104ZFN	25V 0.1U	1						
C731, 32	ECEA0JKA2211	6.3V 220U	2						
C733	ECUZNE104MBN	25V 0.1U	1						
C734	ECEA1AKA2211	10V 220U	1						
C735-37	ECUWNE104ZFN	25V 0.1U	3						
C738	ECUZNE104MBN	25V 0.1U	1						
C739	ECUV1H103KBN	50V 0.01U	1						
C742	ECUV1E273KBN	25V 0.027U	1						
C743	ECUWNE104ZFN	25V 0.1U	1						
C744	ECUV1E123KBN	25V 0.012U	1						
C745	ECUE1C473KBN	16V 0.047U	1						
C747	ECUV1H221KBN	50V 220P	1						
C749	ECUV1H222KBN	50V 2200P	1						
C750, 51	ECUZNE104MBN	25V 0.1U	2						
C753	ECUV1H471KBN	50V 470P	1						
C754	ECUE1H471KBN	50V 470P	1						
C761, 62	ECUE1H471KBN	50V 470P	2						
CN701	RJU035T016-1	SOCKET (16P)	1						
CN702	RJS1A6723-1Q	CONNECTOR (23P)	1						
IC701	AN8837SBE1	IC	1						
IC702	MN662741RPA	IC	1						
IC703	AN8780SBE2	IC	1						
Q701	2SB709STX	TRANSISTOR	1						
Q702	DTC114YKA146	TRANSISTOR	1						
R701	ERJ6GEYJ4R7V	1/10W 4.7	1						
R702	ERJ6GEYJ822V	1/10W 8.2K	1						
R703	ERJ6GEYJ823V	1/10W 82K	1						
R704	ERJ6GEYJ102A	1/10W 1K	1						
R705	ERJ6GEYJ124V	1/10W 120K	1						
R706	ERJ6GEYJ102A	1/10W 1K	1						
R707	ERJ6GEYJ474V	1/10W 470K	1						
R708	ERJ6GEYJ154V	1/10W 150K	1						
R709	ERJ6GEYJ473V	1/10W 47K	1						
R710	ERJ6GEYJ103V	1/10W 10K	1						
R711	ERJ6GEYJ154V	1/10W 150K	1						
R712	ERJ6GEYJ221V	1/10W 220	1						
R715	ERJ6GEYJ122V	1/10W 1.2K	1						
R717-20	ERJ6GEYJ102A	1/10W 1K	4						

# Service Manual

**Supplement 2**



Compact Disc Changer

- SL-PD469
- SL-PD665
- SL-PD687
- SL-PD787
- SL-PD887
- SL-PD987

Please file and use this Service Manual together with the Service Manual for Model No. SL-PD469 Order No. AD9502038A1 (P)  
 Model No. SL-PD665 Order No. AD9501011C1 (PP)  
 Model No. SL-PD687 Order No. AD9501003C1 (P,PC)  
 Model No. SL-PD787 Order No. AD9501009C1 (P,PC)  
 Model No. SL-PD887 Order No. AD9501010C1 (P,PC)  
 Model No. SL-PD987 Order No. AD9501004C1 (PP)

**Colour**  
 (K) ... Black Type

**Note :** This Supplement Service Manual is intended to provide additional information or correction to the existing service manual for model No. SL-PD469, SL-PD665, SL-PD687, SL-PD787, SL-PD887, SL-PD987.  
 Be sure to update your Service Manual for future reference.

**Area**

Suffix for Model No.	Area	Colour
(P)	U.S.A.	(K)
(PC)	Canada	
(PP)	U.S.A. and Canada	

**C.I.T.**

**INGRESO DE INFORMACION**

ARCHIVO : \_\_\_\_\_

F. INGRESO: 8-6-98

\*MASH is a trademark of NTT.

**CD SECTION : RAE0152Z-M TRAVERSE DECK SERIES**

**⚠ WARNING**

This service information is designed for experienced repair technicians only and is not designed for use by the general public. It does not contain warnings or cautions to advise non-technical individuals of potential dangers in attempting to service a product. Products powered by electricity should be serviced or repaired only by experienced professional technicians. Any attempt to service or repair the product or products dealt with in this service information by anyone else could result in serious injury or death.

# Schematic Diagram

## A CD SERVO CIRCUIT

### OPTICAL PICKUP CIRCUIT

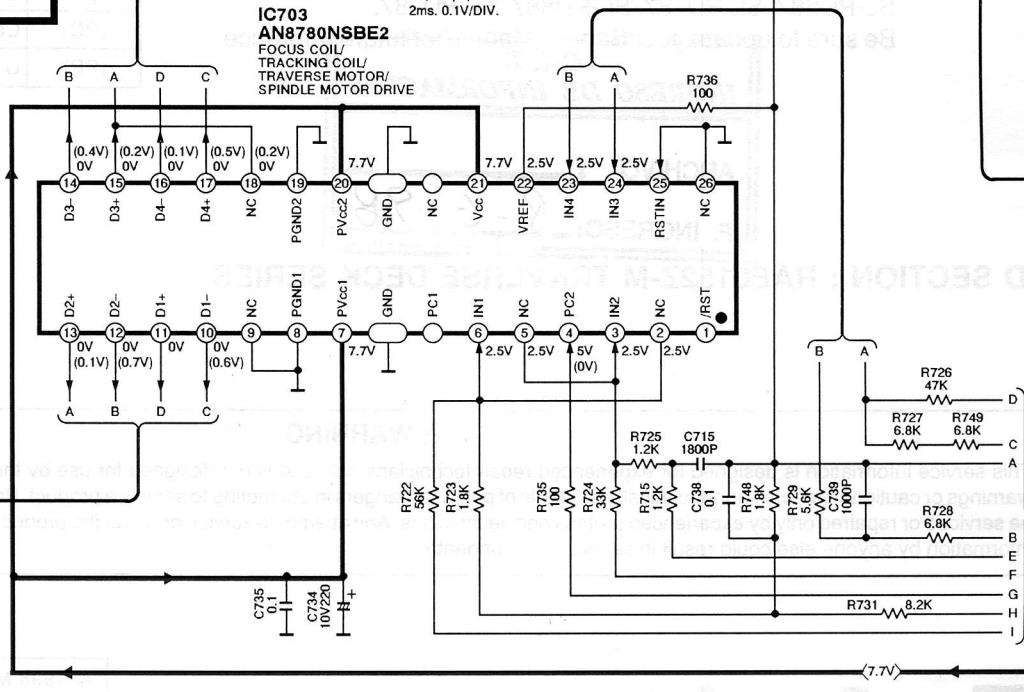
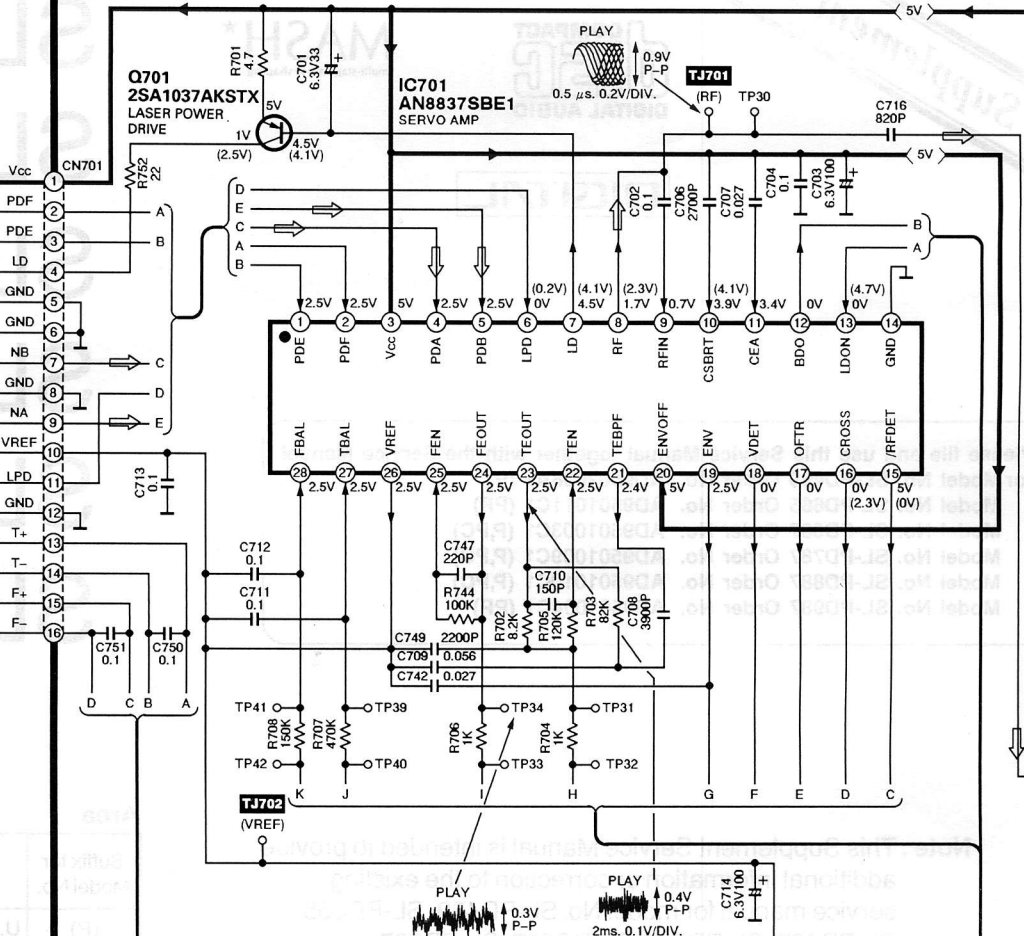
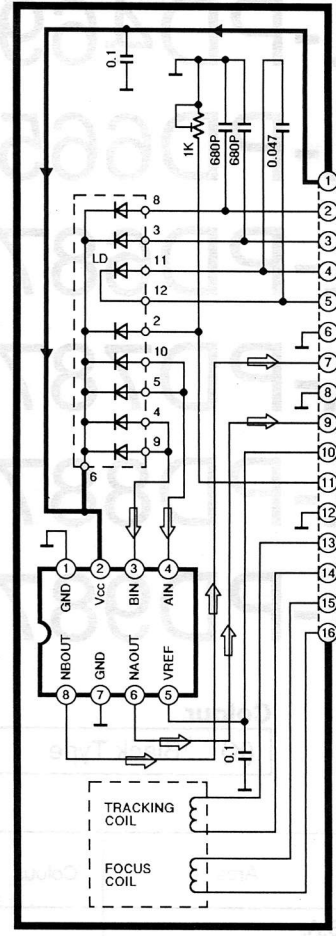



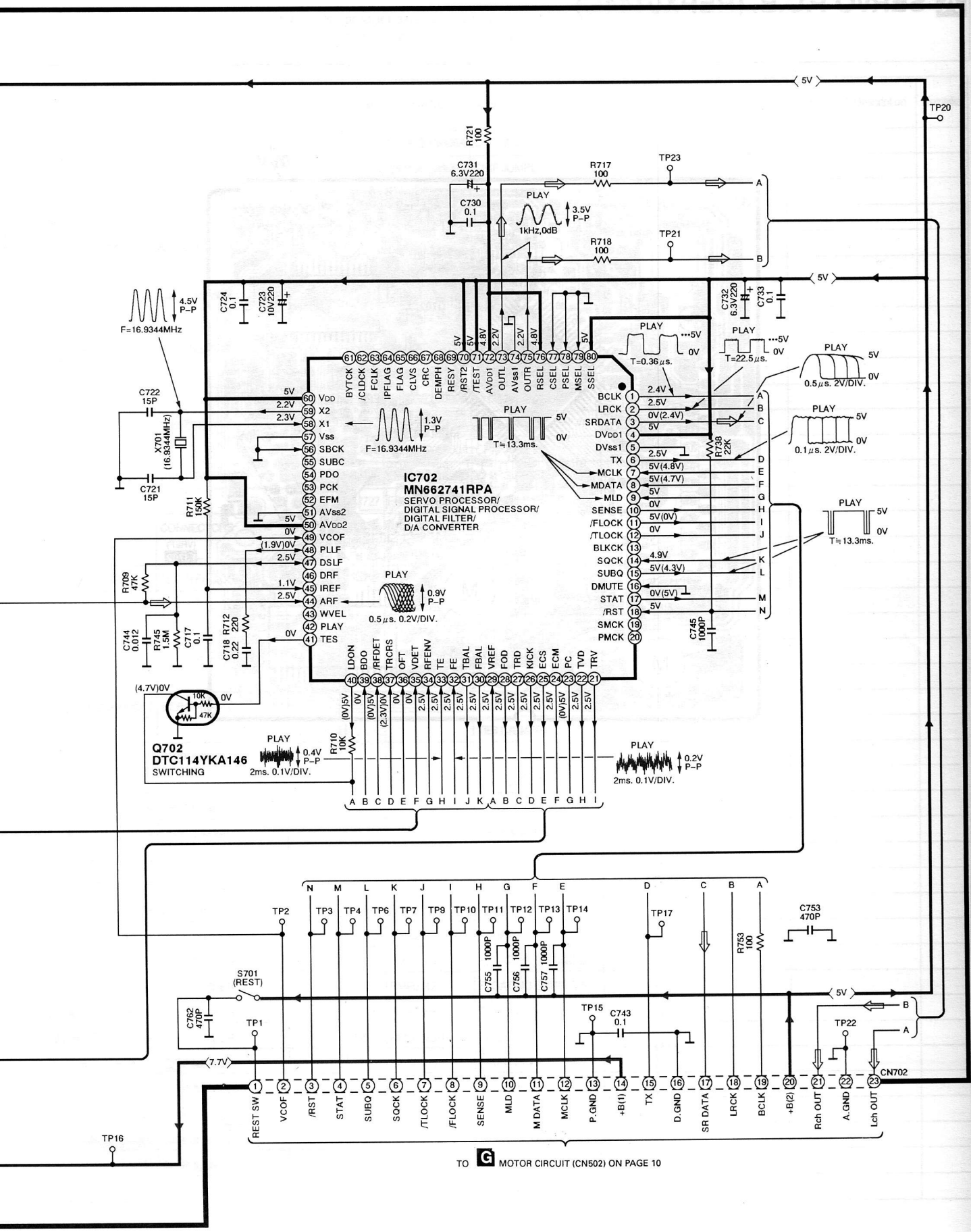

TO MOTOR CIRCUIT (CN502) ON PAGE 10

Printed Circuit Board (NEW)

A SERVO P.C.B. (REPX0144C)

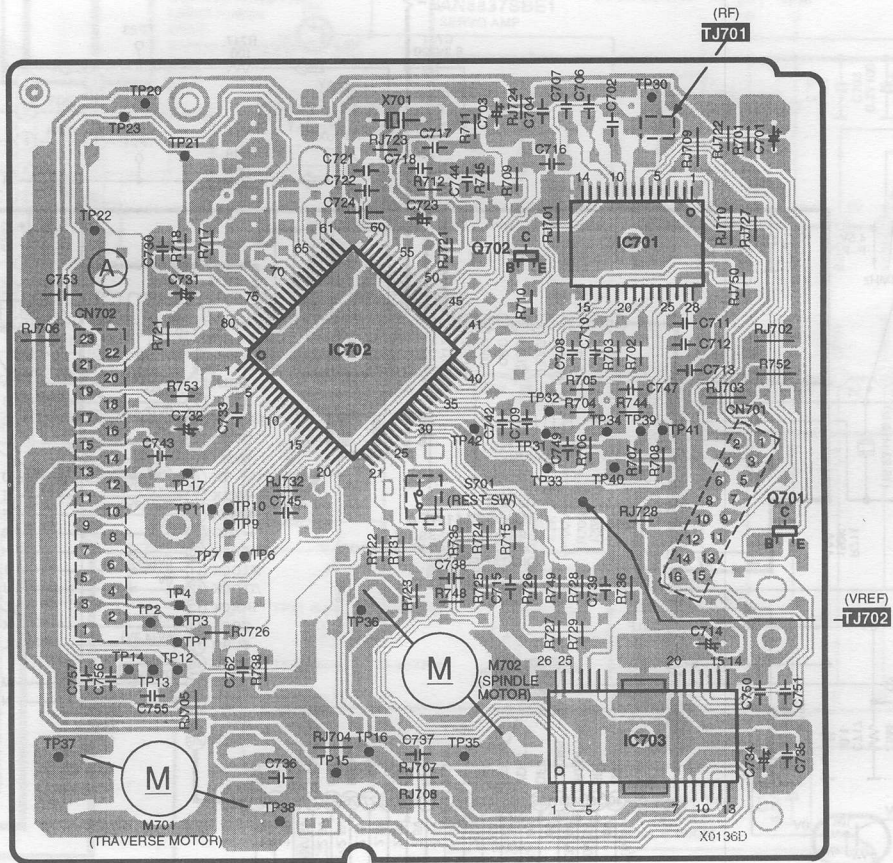

# CD Replacement Parts List

Notes: New and Original are not compatible. Use proper parts as required.  
 [M] Indicates in the Remarks columns indicates parts supplied by MESA.

RefNo.	PartNo.	PartName & Description	Remarks	RefNo.	PartNo.	PartName & Description	Remarks	RefNo.	PartNo.	PartName & Description	Remarks
		<b>INTEGRATED CIRCUITS</b>		RJ709	ERJ8GEY0R00A	CHIP JUMPER					
				RJ709	ERJ8GEY0R00A	CHIP JUMPER					
IC701	AN8837SBE1	IC, HEAD AMP		RJ710	ERJ8GEY0R00A	CHIP JUMPER					
IC702	MN662741RPA	IC, DIGITAL LSI		RJ710	ERJ8GEY0R00A	CHIP JUMPER					
IC703	AN8780NSBE2	IC, 4 CH DRIVE		RJ721	ERJ6GEY0R00A	CHIP JUMPER					
				RJ721	ERJ6GEY0R00A	CHIP JUMPER					
		<b>TRANSISTORS</b>		RJ722	ERJ6GEY0R00A	CHIP JUMPER					
				RJ722	ERJ6GEY0R00A	CHIP JUMPER					
Q701	2SA1037AKSTX	TRANSISTOR		RJ723	ERJ6GEY0R00A	CHIP JUMPER					
Q702	DTC114YKA146	TRANSISTOR		RJ723	ERJ6GEY0R00A	CHIP JUMPER					
				RJ724	ERJ6GEY0R00A	CHIP JUMPER					
		<b>SWITCHES</b>		RJ724	ERJ6GEY0R00A	CHIP JUMPER					
				RJ726	ERJ6GEY0R00A	CHIP JUMPER					
S701	RSH1A043-U	REST SWITCH		RJ726	ERJ6GEY0R00A	CHIP JUMPER					
				RJ727	ERJ6GEY0R00A	CHIP JUMPER					
		<b>CONNECTORS</b>		RJ727	ERJ6GEY0R00A	CHIP JUMPER					
				RJ728	ERJ6GEY0R00A	CHIP JUMPER					
CN701	RJS2A6016	16 PIN FFC CONNECTOR		RJ728	ERJ6GEY0R00A	CHIP JUMPER					
CN702	RJS1A6723-1Q	23 PIN FFC CONNCTOR		RJ732	ERJ6GEY0R00A	CHIP JUMPER					
				RJ732	ERJ6GEY0R00A	CHIP JUMPER					
		<b>OSCILLATORS</b>		RJ750	ERJ6GEY0R00A	CHIP JUMPER					
				RJ750	ERJ6GEY0R00A	CHIP JUMPER					
X701	RSXZ16M9M01T	CERAMIC OSC									
						<b>TEST JUMPER</b>					
		<b>CHIP JUMPERS</b>									
				TJ701	EYF8CU	TEST JUMPER					
RJ701	ERJ6GEY0R00A	CHIP JUMPER									
RJ701	ERJ6GEY0R00A	CHIP JUMPER				<b>MECHANISMS</b>					
RJ702	ERJ8GEY0R00A	CHIP JUMPER									
RJ702	ERJ8GEY0R00A	CHIP JUMPER		116	RAE0152Z-M	TRV					
RJ703	ERJ8GEY0R00A	CHIP JUMPER		116-1	SHGD113-1	FLOATING CUSHION					
RJ703	ERJ8GEY0R00A	CHIP JUMPER		116-2	SNSD38	SCREW					
RJ704	ERJ8GEY0R00A	CHIP JUMPER		117	RME0109	FLOATING SPRING B					
RJ704	ERJ8GEY0R00A	CHIP JUMPER		118	RME0142	FLOATING SPRING A					
RJ705	ERJ8GEY0R00A	CHIP JUMPER		119	RMR0698-K	TRY CHASSIS					
RJ705	ERJ8GEY0R00A	CHIP JUMPER		120	RMS0123-1	FIXED PIN B					
RJ706	ERJ8GEY0R00A	CHIP JUMPER		121	RMS0350	FIXED PIN A					
RJ706	ERJ8GEY0R00A	CHIP JUMPER		124	XTN2+6G	PCB SCREW					
RJ707	ERJ8GEY0R00A	CHIP JUMPER									
RJ707	ERJ8GEY0R00A	CHIP JUMPER									
RJ708	ERJ8GEY0R00A	CHIP JUMPER									
RJ708	ERJ8GEY0R00A	CHIP JUMPER									

## ■ Resistors & Capacitors (Servo P.C.B.)

Notes : \* Capacitor values are in microfarad ( $\mu\text{F}$ ) unless specified otherwise, P=Pico-farads (pF) F=Farads (F)  
 \* Resistors values are in ohms, unless specified otherwise, 1k=1,000(OHM), 1M=1,000k(OHM)

RefNo.	PartNo.	Values&Remarks	RefNo.	PartNo.	Values&Remarks	RefNo.	PartNo.	Values&Remarks
		<b>RESISTORS</b>			<b>CAPACITORS</b>	C756	ECUZ1H102KBN	1000P 50V
R701	ERJ6GEYJ4R7A	4.7 1/10W	C701	ECEA0JKA330I	33 6.3V	C757	ECUZ1H102KBN	1000P 50V
R702	ERJ6GEYJ822A	8.2K 1/10W	C702	ECUZ1E104MBN	0.1 25V	C762	ECUZ1H471KBN	470P 50V
R703	ERJ6GEYJ823A	82K 1/10W	C703	ECEA0JKA101I	100 6.3V			
R704	ERJ6GEYJ102A	1K 1/10W	C704	ECUZ1E104MBN	0.1 25V			
R705	ERJ6GEYJ124A	120K 1/10W	C706	ECUZ1H272KBN	2700P 50V			
R706	ERJ6GEYJ102A	1K 1/10W	C707	ECUZ1E273KBN	0.027 25V			
R707	ERJ6GEYJ474A	470K 1/10W	C708	ECUZ1H392KBN	3900P 50V			
R708	ERJ6GEYJ154A	150K 1/10W	C709	ECUZ1E563KBN	0.056 25V			
R709	ERJ6GEYJ473A	47K 1/10W	C710	ECUV1H151KCN	150P 50V			
R710	ERJ6GEYJ103A	10K 1/10W	C711	ECUZ1E104ZFN	0.1 25V			
R711	ERJ6GEYJ154A	150K 1/10W	C712	ECUZ1E104ZFN	0.1 25V			
R712	ERJ6GEYJ221A	220 1/10W	C713	ECUZ1E104MBN	0.1 25V			
R715	ERJ6GEYJ122A	1.2K 1/10W	C714	ECEA0JKA101I	100 6.3V			
R717	ERJ6GEYJ101A	100 1/10W	C715	ECUZ1H182KBN	1800P 50V			
R718	ERJ6GEYJ101A	100 1/10W	C716	ECUZ1H821KBN	820P 50V			
R721	ERJ6GEYJ101A	100 1/10W	C717	ECUZ1E104ZFN	0.1 25V			
R722	ERJ6GEYJ563A	56K 1/10W	C718	ECUZ1C224KBN	0.22 16V			
R723	ERJ6GEYJ182A	1.8K 1/10W	C721	ECUZ1H150JCN	15P 50V			
R724	ERJ6GEYJ333A	33K 1/10W	C722	ECUZ1H150JCN	15P 50V			
R725	ERJ6GEYJ122A	1.2K 1/10W	C723	ECEA1AKA221I	220 10V			
R726	ERJ6GEYJ473A	47K 1/10W	C724	ECUZ1E104MBN	0.1 25V			
R727	ERJ6GEYJ682A	6.8K 1/10W	C730	ECUZ1E104ZFN	0.1 25V			
R728	ERJ6GEYJ682A	6.8K 1/10W	C731	ECEA0JKA221I	220 6.3V			
R729	ERJ6GEYJ562A	5.6K 1/10W	C732	ECEA0JKA221I	220 6.3V			
R731	ERJ6GEYJ822A	8.2K 1/10W	C733	ECUZ1E104MBN	0.1 25V			
R735	ERJ6GEYJ101A	100 1/10W	C734	ECEA1AKA221I	220 10V			
R736	ERJ6GEYJ101A	100 1/10W	C735	ECUZ1E104ZFN	0.1 25V			
R738	ERJ6GEYJ223A	22K 1/10W	C736	ECUZ1E104ZFN	0.1 25V			
R744	ERJ6GEYJ104A	100K 1/10W	C737	ECUZ1E104ZFN	0.1 25V			
R745	ERJ6GEYJ155A	1.5M 1/10W	C738	ECUZ1E104MBN	0.1 25V			
R748	ERJ6GEYJ182A	1.8K 1/10W	C739	ECUZ1H102KBN	1000P 50V			
R749	ERJ6GEYJ682A	6.8K 1/10W	C742	ECUZ1E273KBN	0.027 25V			
R752	ERJ8GEYJ220A	22 1/8W	C743	ECUZ1E104ZFN	0.1 25V			
R753	ERJ6GEYJ102A	1K 1/10W	C744	ECUZ1E123KBN	0.012 25V			
			C745	ECUZ1H102KBN	1000P 50V			
			C747	ECUV1H221KBN	220P 50V			
			C749	ECUZ1H222KBN	2200P 50V			
			C750	ECUZ1E104MBN	0.1 25V			
			C751	ECUZ1E104MBN	0.1 25V			
			C753	ECUZ1H471KBM	470P 50V			
			C755	ECUZ1H102KBN	1000P 50V			

■ CD Loading Unit Parts Location

