

QRG  
L S 2 2 0 8



**symbol**<sup>®</sup>



© 2003 SYMBOL TECHNOLOGIES, INC. All rights reserved.

Symbol reserves the right to make changes to any product to improve reliability, function, or design.

Symbol does not assume any product liability arising out of, or in connection with, the application or use of any product, circuit, or application described herein.

No license is granted, either expressly or by implication, estoppel, or otherwise under any patent right or patent, covering or relating to any combination, system, apparatus, machine, material, method, or process in which Symbol products might be used. An implied license exists only for equipment, circuits, and subsystems contained in Symbol products.

Symbol and the Symbol logo are registered trademarks of Symbol Technologies, Inc. Other product names mentioned in this manual may be trademarks or registered trademarks of their respective companies and are hereby acknowledged.

Symbol Technologies, Inc.

One Symbol Plaza

Holtsville, N.Y. 11742-1300

<http://www.symbol.com>

#### Patents

This product is covered by one or more of the following U.S. and foreign Patents:

U.S. Patent No. 4,593,186; 4,603,262; 4,607,156; 4,652,750; 4,673,805; 4,736,095;  
4,758,717; 4,760,248; 4,806,742; 4,816,660; 4,845,350; 4,896,026; 4,897,532; 4,923,281;  
4,933,538; 4,992,717; 5,015,833; 5,017,765; 5,021,641; 5,029,183; 5,047,617; 5,103,461;  
5,113,445; 5,130,520; 5,140,144; 5,142,550; 5,149,950; 5,157,687; 5,168,148; 5,168,149;  
5,180,904; 5,216,232; 5,229,591; 5,230,088; 5,235,167; 5,243,655; 5,247,162; 5,250,791;  
5,250,792; 5,260,553; 5,262,627; 5,262,628; 5,266,787; 5,278,398; 5,280,162; 5,280,163;  
5,280,164; 5,280,498; 5,304,786; 5,304,788; 5,306,900; 5,324,924; 5,337,361; 5,367,151;  
5,373,148; 5,378,882; 5,396,053; 5,396,055; 5,399,846; 5,408,081; 5,410,139; 5,410,140;  
5,412,198; 5,418,812; 5,420,411; 5,436,440; 5,444,231; 5,449,891; 5,449,893; 5,468,949;  
5,471,042; 5,478,998; 5,479,000; 5,479,002; 5,479,441; 5,504,322; 5,519,577; 5,528,621;  
5,532,469; 5,543,610; 5,545,889; 5,552,592; 5,557,093; 5,578,810; 5,581,070; 5,589,679;  
5,589,680; 5,608,202; 5,612,531; 5,619,028; 5,627,359; 5,637,852; 5,664,229; 5,668,803;  
5,675,139; 5,693,929; 5,698,835; 5,705,800; 5,714,746; 5,723,851; 5,734,152; 5,734,153;  
5,742,043; 5,745,794; 5,754,587; 5,762,516; 5,763,863; 5,767,500; 5,789,728; 5,789,731;  
5,808,287; 5,811,785; 5,811,787; 5,815,811; 5,821,519; 5,821,520; 5,823,812; 5,828,050;  
5,848,064; 5,850,078; 5,861,615; 5,874,720; 5,875,415; 5,900,617; 5,902,989; 5,907,146;  
5,912,450; 5,914,478; 5,917,173; 5,920,059; 5,923,025; 5,929,420; 5,945,658; 5,945,659;  
5,946,194; 5,959,285; 6,002,918; 6,021,947; 6,029,894; 6,031,830; 6,036,098; 6,047,892;  
6,050,491; 6,053,413; 6,056,200; 6,065,678; 6,067,297; 6,082,621; 6,084,528; 6,088,482;  
6,092,725; 6,101,483; 6,102,293; 6,104,620; 6,114,712; 6,115,678; 6,119,944; 6,123,265;  
6,131,814; 6,138,180; 6,142,379; 6,172,478; 6,176,428; 6,178,426; 6,186,400; 6,188,681;  
6,209,788; 6,209,789; 6,216,951; 6,220,514; 6,243,447; 6,244,513; 6,247,647; 6,308,061;  
6,250,551; 6,295,031; 6,308,061; 6,308,892; 6,321,990; 6,328,213; 6,330,244; 6,336,587;  
6,340,114; 6,340,115; 6,340,119; 6,348,773; 6,380,949; 6,394,355; D305,885; D341,584;  
D344,501; D359,483; D362,453; D363,700; D363,918; D370,478; D383,124; D391,250;  
D405,077; D406,581; D414,171; D414,172; D418,500; D419,548; D423,468; D424,035;  
D430,158; D430,159; D431,562; D436,104.  
Invention No. 55,358; 62,539; 69,060; 69,187, NI-068564 (Taiwan); No. 1,601,796; 1,907,875;  
1,955,269 (Japan); European Patent 367,299; 414,281; 367,300; 367,298; UK 2,072,832;  
France 81/03938; Italy 1,138,713  
rev. 06/02

## **Introduction**

The LS 2208 scanner combines excellent scanning performance and advanced ergonomics to provide the best value in a lightweight laser scanner.

Whether used as a hand-held scanner or in hands-free mode in a stand, the LS 2208 scanner ensures comfort and ease of use for extended periods of time.

## Parts of the Scanner

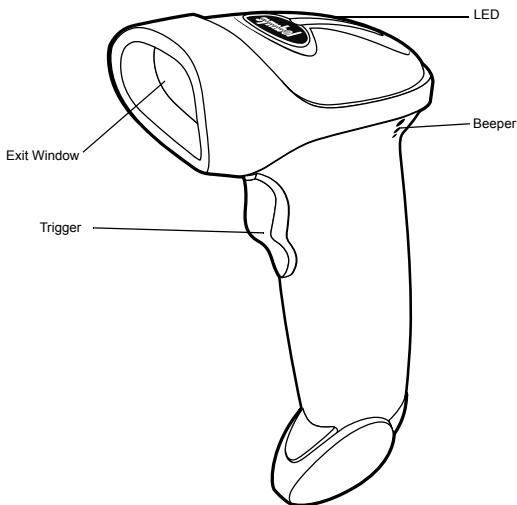

## Installing the Interface Cable

1. Plug the interface cable modular connector into the cable interface port on the bottom of the scanner's handle.

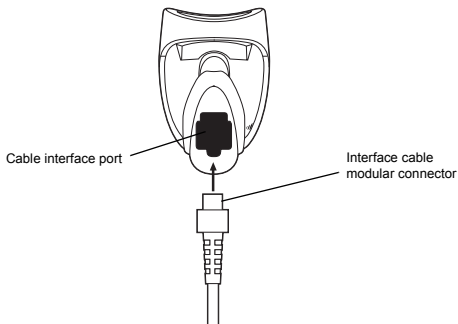

2. Connect the other end of the interface cable to the host.
3. Connect the power supply to the cable (if necessary).
4. Scan the appropriate bar code(s) beginning on page 65 to communicate with the host.

## Removing the Interface Cable

Unplug the installed cable's modular connector by depressing the connector clip with the tip of a screwdriver.

## Aiming

Note: The scanner performs best when it is not exactly perpendicular to the bar code.

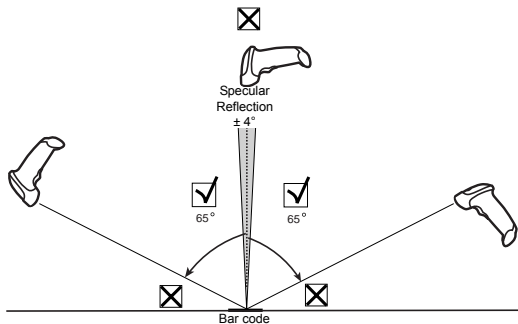

## Scanning In Hand-Held Mode

1. Ensure all connections are secure.
2. Aim the scanner at the bar code.

# Q u i c k R e f e r e n c e

3. Ensure the scan line crosses every bar and space of the symbol.

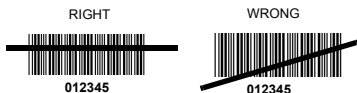

4. Upon successful decode, the scanner beeps and the LED turns green.

## Scanning in Hands-Free Mode

In the stand, the scanner is in constant-on mode. When you remove the scanner from the stand it operates in its normal hand-held mode.

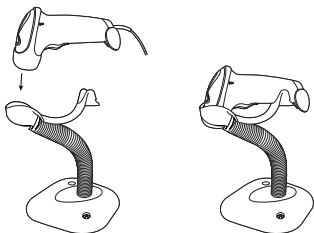

1. Insert scanner in stand.
2. Present bar code and ensure the scan line crosses every bar and space of the symbol.
3. Upon successful decode, the scanner beeps and the LED turns green.

## Troubleshooting

Problem	Possible Cause	Possible Solutions
Nothing happens when you follow the operating instructions.	No power to the scanner.	Check the system power. Ensure the power supply is connected if your configuration requires a power supply.
	Interface/power cables are loose.	Check for loose cable connections.
Laser comes on, but symbol does not decode.	Scanner is not programmed for the correct bar code type.	Ensure the scanner is programmed to read the type of bar code you are scanning.
	Bar code symbol is unreadable.	Check the symbol to make sure it is not defaced. Try scanning test symbols of the same bar code type.
	Distance between scanner and bar code is incorrect.	Move the scanner closer to or further from the bar code.
Symbol is decoded, but not transmitted to the host.	Scanner is not programmed for the correct host type.	Scan the appropriate host type bar code.



# Q u i c k R e f e r e n c e

<b>Problem</b>	<b>Possible Cause</b>	<b>Possible Solutions</b>
Scanned data is incorrectly displayed on the host.	Scanner is not programmed to work with the host.	<p>Ensure proper host is selected.</p> <p>Check the scanner's host type parameters or editing options. For RS-232, ensure the scanner's communication parameters match the host's settings.</p> <p>For a keyboard wedge configuration, ensure the system is programmed for the correct keyboard type, and the CAPS LOCK key is off .</p> <p>Ensure editing options (e.g., UPC-E to UPC-A Conversion) are properly programmed.</p>

L S 2 2 0 8

A large, light gray watermark logo consisting of the letters 'Q', 'R', and 'G' in a serif font, positioned behind the product code 'LS 2208'.

## **Présentation**

Le lecteur LS 2208 combine une excellente performance de lecture et des composants ergonomiques avancés, résultant en un lecteur laser ultra-léger d'un excellent rapport qualité-prix. Utilisé en mode portable ou en mode mains-libres, le lecteur LS 2208 assure un confort et une facilité d'utilisation pour des périodes de temps prolongées.

## Description du lecteur

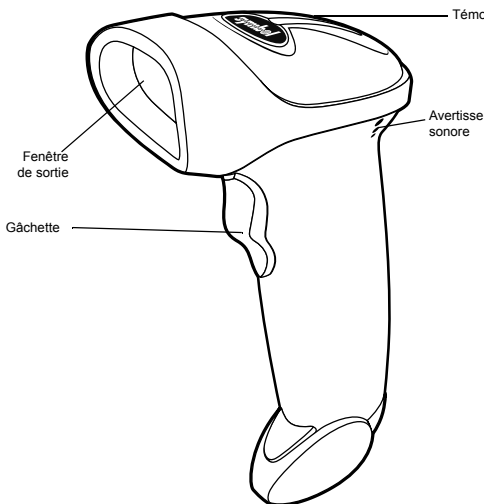

## Installation du câble d'interface

1. Branchez le connecteur modulaire du câble d'interface au port correspondant dans la partie inférieure de la poignée du lecteur.

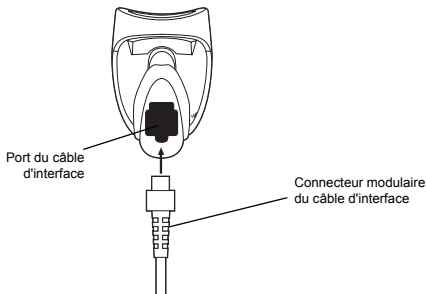

2. Branchez l'autre extrémité du câble d'interface à l'ordinateur central.
3. Branchez le câble au secteur (si nécessaire).
4. Pour que le lecteur communique avec l'ordinateur central, lisez le/les code(s) à barres prévu(s) à cet effet à la page 65.

## Retrait du câble d'interface

Pour débrancher le connecteur modulaire du câble, appuyez sur le clip du connecteur avec l'extrémité d'un tourne-vis.

## Visée

Remarque : Le lecteur lit mieux lorsqu'il n'est pas complètement perpendiculaire

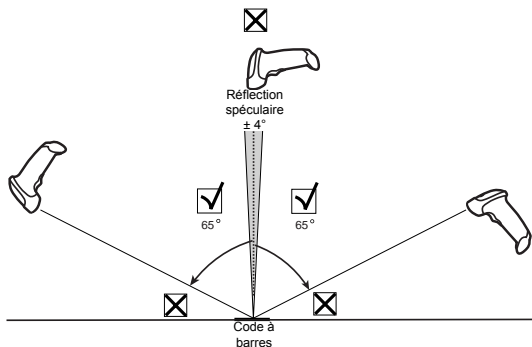

## Lecture en mode portable

1. Vérifiez tous les branchements.
2. Dirigez le lecteur sur le code à barres.
3. La ligne de lecture doit impérativement recouvrir toutes les barres et tous les espaces du code.

L S 2 2 0 8



4. Lorsque la lecture est terminée, le lecteur émet un bip sonore et le témoin vire au vert.

## Lecture en mode mains-libres

Lorsque le lecteur est placé dans son support, il est en constante opération. Si vous le sortez de son support, il passe en mode portable normal.

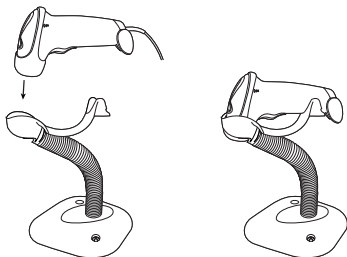

1. Placez le lecteur dans son support.
2. Présentez le code devant la fenêtre de sortie du lecteur en veillant à ce que la ligne de lecture couvre bien toutes les barres et tous les espaces du code.
3. Lorsque la lecture est terminée, le lecteur émet un bip sonore et le témoin vire au vert.

## Dépannage

Problème	Cause éventuelle	Solutions possibles
Vous avez suivi les instructions d'utilisation et pourtant rien ne se produit.	Le lecteur n'est pas alimenté.	Vérifiez l'alimentation du système. Si votre lecteur doit être alimenté au secteur, vérifiez qu'il est bien branché.
	Les câbles d'interface/d'alimentation sont mal branchés.	Vérifiez les branchements.
Le faisceau s'allume mais le code n'est pas déchiffré.	Le lecteur n'est pas programmé pour ce type de code à barres.	Vérifiez que le lecteur est compatible avec le type de code à barres que vous essayez de lire.
	Le code à barres est illisible.	Vérifiez que le code n'est pas endommagé. Essayez de lire des codes du même type.
	La distance entre le lecteur et le code à barres est incorrecte.	Rapprochez ou éloignez le code à barres du lecteur.

Problème	Cause éventuelle	Solutions possibles
Le code est déchiffré, mais n'est pas transmis à l'ordinateur central.	Le lecteur n'est pas programmé pour le bon ordinateur central.	Lisez le code à barres correspondant à l'ordinateur central utilisé.
L'affichage sur l'ordinateur central des données lues est incorrect.	Le lecteur n'a pas été programmé pour fonctionner avec cet ordinateur central.	<p>Assurez-vous d'avoir sélectionné le bon ordinateur central.</p> <p>Vérifiez les paramètres et les options d'édition de l'ordinateur central.</p> <p>Pour le RS-232, vérifiez que les paramètres de communication du lecteur correspondent à la configuration de l'ordinateur central.</p> <p>Pour l'émulation clavier, vérifiez que le système a été configuré pour le bon type de clavier et que la touche VERROUILLAGE est désactivée.</p> <p>Vérifiez que les options d'édition (par ex. Conversion UPC-E à UPC-A) sont correctement configurées.</p>



## **Introduzione**

Lo scanner della 2208 combina eccellenti prestazioni di lettura a caratteristiche ergonomiche avanzate, offrendo il miglior rapporto qualità/prezzo per uno scanner laser leggero e facilmente manovrabile. Sia usato in modalità portatile che su di un supporto in modalità mani libere, lo scanner LS 2208 assicura confort e agevolezza d'utilizzo prolungati.

L S 2 2 0 8

## Parti dello scanner

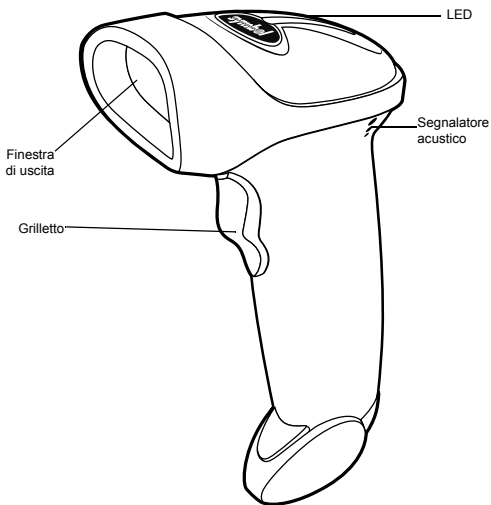

## Installazione del cavo di interfaccia

1. Inserire il connettore modulare del cavo di interfaccia nella relativa porta, nella parte inferiore del manico dello scanner.

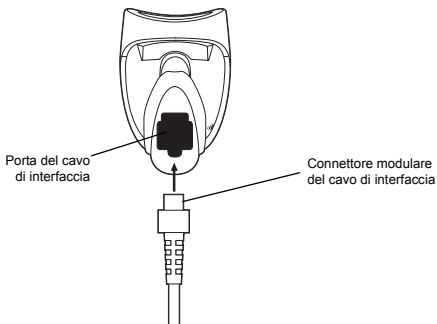

2. Collegare l'altra estremità del cavo di interfaccia all'host.
3. Collegare il cavo dell'alimentazione, se necessario.
4. Eseguire la scansione del codice o dei codici a barre riportati a pag. 65 per comunicare con l'host.

## Rimozione del cavo di interfaccia

Scollegare il connettore modulare del cavo installato premendo il fermaglio del connettore con la punta di un cacciavite.

## Puntamento

Nota: Lo scanner funziona meglio quando non è perfettamente perpendicolare al codice a barre.

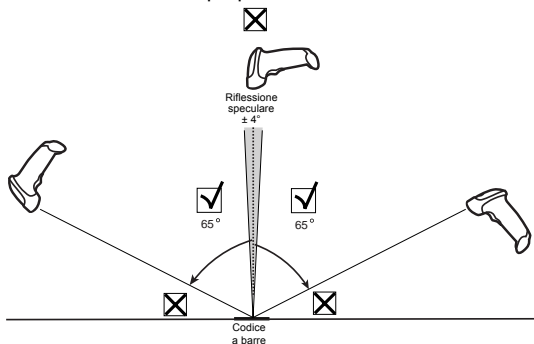

## Modalità di scansione portatile

1. Assicurarsi che tutte le connessioni siano a posto.
2. Rivolgere lo scanner sul codice a barre.
3. Assicurarsi che la linea di scansione incroci ogni barra e ogni spazio del simbolo.

# G u i d a   r a p i d a



4. Dopo la decodifica con esito positivo, lo scanner emette un segnale acustico e il LED diventa verde.

## Modalità di scansione a mani libere

Posizionato sul supporto, lo scanner è sempre attivo. Quando viene tolto dal supporto, lo scanner funziona nella sua normale modalità portatile.

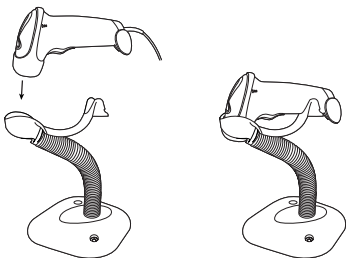

1. Inserire lo scanner nel supporto.
2. Presentare il codice a barre e assicurarsi che la linea di scansione incroci ogni barra e ogni spazio del simbolo.
3. Dopo la decodifica con esito positivo, lo scanner emette un segnale acustico e il LED diventa verde.

## Risoluzione dei problemi

Problema	Possibile causa	Possibile soluzione
Eseguendo le istruzioni d'uso, non accade nulla.	Lo scanner non riceve alimentazione.	Controllare l'alimentazione del sistema. Verificare il collegamento dell'alimentazione se questa è richiesta dalla configurazione.
	La connessione dei cavi di interfaccia/alimentazione si è allentata.	Controllare se la connessione dei cavi si è allentata.
Il laser è attivo, ma il simbolo non viene decodificato.	Lo scanner non è programmato per il corretto tipo di codice a barre.	Assicurarsi che lo scanner sia programmato per leggere il tipo di codice a barre da sottoporre a scansione.
	Il simbolo del codice a barre è illeggibile.	Controllare il simbolo per assicurarsi che non sia danneggiato. Eseguire la lettura di simboli di prova dello stesso tipo di codice a barre.
	La distanza tra lo scanner e il codice a barre non è corretta.	Avvicinare o allontanare lo scanner al o dal codice a barre.
Il simbolo viene decodificato ma non viene trasmesso all'host.	Lo scanner non è programmato per il corretto tipo di host.	Eseguire la lettura del codice a barre del tipo di host corretto.

# G u i d a r a p i d a

<b>Problema</b>	<b>Possibile causa</b>	<b>Possibile soluzione</b>
I dati letti vengono visualizzati in modo errato sull'host.	Lo scanner non è programmato per funzionare con l'host.	<p>Assicurarsi che sia stato selezionato l'host appropriato. Verificare le opzioni di modifica o i parametri del tipo di host dello scanner.</p> <p>Sul modello RS-232, assicurarsi che i parametri di comunicazione dello scanner corrispondano alle impostazioni dell'host.</p> <p>In emulazione di tastiera, accertarsi che il sistema sia programmato per il tipo di tastiera appropriato e che il tasto CAPS LOCK non sia selezionato.</p> <p>Verificare che le opzioni di modifica (ad es. per la conversione UPC-E - UPC-A) siano correttamente programmate.</p>



## **Einführung**

Der Scanner LS 2208 kombiniert eine exzellente Scanleistung mit fortschrittlicher Ergonomie und bietet damit das beste Preis-/Leistungsverhältnis für leichtgewichtige Laserscanner. Ob Sie ihn nun im manuellen oder stationären Modus verwenden, der LS 2208 Scanner garantiert auch über über längere Zeiträume stets Komfort und Bedienerfreundlichkeit.



## Teile des Scanners

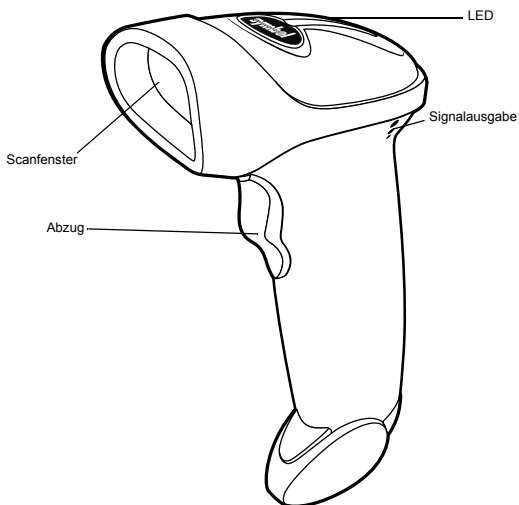

## Installieren des Schnittstellenkabels

1. Verbinden Sie den Modularstecker des Kabels mit dem Schnittstellenanschluss unten im Griff des Scanners.

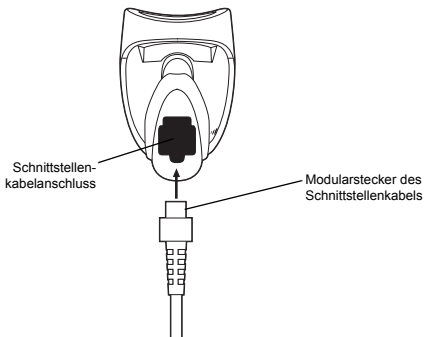

2. Schließen Sie das andere Ende des Schnittstellenkabels an den Host an.
3. Schließen Sie das Kabel an die Stromversorgung an (falls notwendig).
4. Scannen Sie die entsprechenden Strichcodes auf Seite 65 ff., um die Kommunikation mit dem Host einzurichten.

## Entfernen des Schnittstellenkabels

Lösen Sie den Modularstecker des Schnittstellenkabels, indem Sie mit einem Schraubendreher auf den Steckerclip drücken.

## Zielen

Hinweis: Der Scanner funktioniert am besten, wenn er nicht genau rechtwinklig auf den Strichcode gerichtet ist.

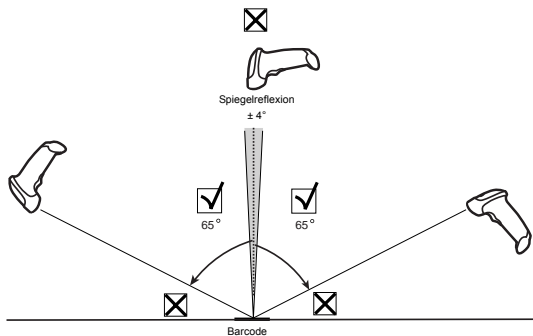

## Scannen im Freihandmodus

1. Vergewissern Sie sich, dass alle Anschlüsse korrekt sind.

L S 2 2 0 8

# QRG

2. Zielen Sie mit dem Scanner auf den Strichcode.
3. Stellen Sie sicher, dass die Scanzeile über alle Striche und Zwischenräume des Symbols geführt wird.



4. Ist die Dekodierung erfolgt, gibt der Scanner einen Piepton aus und die LED leuchtet grün.

## Scannen im stationären Modus

Im Tischständer bleibt der Scanner konstant eingeschaltet. Wenn Sie den Scanner aus dem Ständer nehmen, schaltet er in den normalen Handbetrieb um.

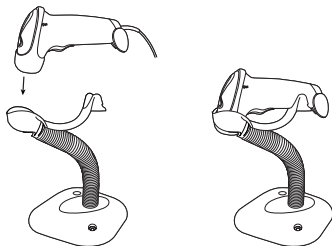

1. Setzen Sie den Scanner in den Ständer ein.
2. Halten Sie den Barcode vor den Scanner. Es muss gewährleistet sein, dass die Scanzeile über alle Balken und Zwischenräume des Symbols geführt wird.

# K u r z ü b e r s i c h t

- Ist die Dekodierung erfolgt, gibt der Scanner einen Piepton aus und die LED leuchtet grün.

## Problembehebung

Problem	Mögliche Ursache	Lösungsvorschläge
Es passiert nichts, obwohl Sie die Bedienungsanleitung befolgt haben.	Die Stromversorgung zum Scanner ist unterbrochen.	Prüfen Sie die Stromanschlüsse. Stellen Sie sicher, dass die Stromversorgung angeschlossen ist (sofern Ihr System über Netzstrom arbeitet).
	Die Schnittstellen-/Stromkabel sitzen nicht richtig.	Prüfen Sie, ob die Kabel korrekt angeschlossen sind.
Der Laser ist zwar aktiviert, es erfolgt allerdings keine Symboldekodierung.	Der Scanner ist auf das Lesen dieses Strichcodetyps nicht programmiert.	Prüfen Sie, ob der Scanner auf das Lesen dieses Strichcodetyps programmiert ist.
	Das Strichcodesymbol ist beschädigt.	Prüfen Sie, ob das Strichcode beschädigt oder nicht korrekt aufgedruckt ist. Scannen Sie testweise andere Strichcodes desselben Typs.
	Der Strichcode ist zu weit vom Scanner entfernt.	Verringern bzw. vergrößern Sie die Distanz zwischen Strichcode und Scanner.
Das Symbol wird dekodiert, aber nicht an den Host übertragen.	Der Scanner ist nicht auf den korrekten Hosttyp programmiert.	Scannen Sie den korrekten Strichcode für die Hosttyp-Programmierung.

Problem	Mögliche Ursache	Lösungsvorschläge
<p>Die gescannten Daten werden auf dem Host nicht korrekt angezeigt.</p>	<p>Der Scanner ist für ein korrektes Arbeiten mit dem Host nicht programmiert.</p>	<p>Prüfen Sie, ob der richtige Host ausgewählt ist. Prüfen Sie die Hosttypparameter des Scanners oder die Bearbeitungsoptionen. Wenn Sie die RS-232-Schnittstelle verwenden, stellen Sie sicher, dass die Kommunikationsparameter des Scanners mit den Einstellungen des POS-Hosts übereinstimmen.</p> <p>Wenn Sie die Keyboard Wedge-Schnittstelle verwenden, stellen Sie sicher, dass der Scanner mit dem entsprechenden Ländercode programmiert und die Feststelltaste (Seite 66) deaktiviert ist.</p> <p>Prüfen Sie, ob die Bearbeitungsoptionen (z. B. UPCE-zu-UPCA-Konvertierung) richtig programmiert sind.</p>

## **Introducción**

El scanner LS 2208 combina excelentes prestaciones de lectura y avanzado diseño ergonómico para ofrecer el mejor valor en un scanner de láser de poco peso. Ya se utilice en modo manual o en modo manos libres con soporte, el scanner LS 2208 garantiza comodidad y facilidad de uso durante largos períodos de tiempo.

## Partes del scanner

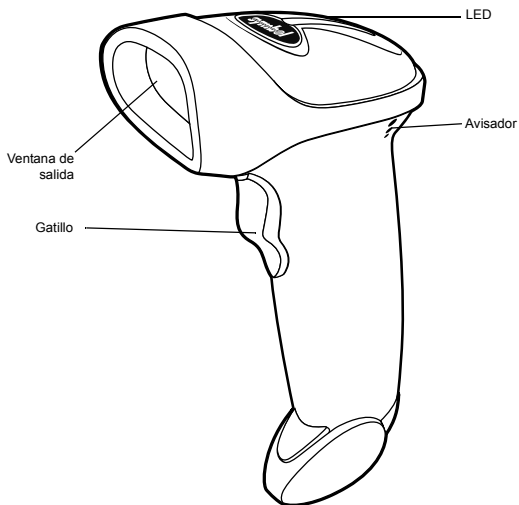



## Instalación del cable de interfaz

1. Enchufe el conector modular del cable de interfaz en el puerto para cable de interfaz (parte inferior del mango del scanner).

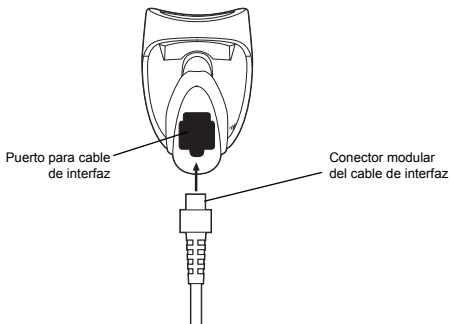

2. Conecte el otro extremo del cable de interfaz al host.
3. Conecte la fuente de alimentación al cable (si es necesario).
4. Realice una lectura de los códigos de barras apropiados empezando en la página 65 a fin de establecer comunicación con el host.

## Extracción del cable de interfaz

Desenchufe el conector modular del cable instalado presionando el clip del conector con la punta de un destornillador.

## Cómo apuntar al código de barras

**Nota:** El scanner ofrece mayor rendimiento cuando no está situado exactamente en dirección perpendicular al código de barras.

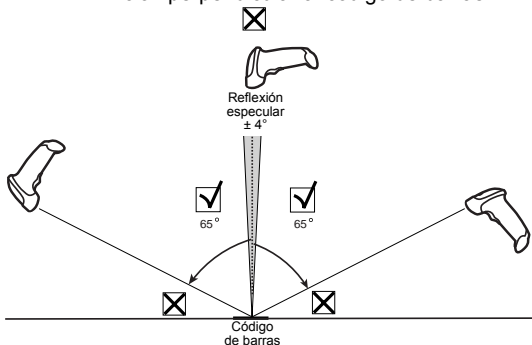

## Lectura en modo manual

1. Asegúrese de que todas las conexiones son seguras.
2. Apunte el scanner hacia el código de barras.
3. Cerciórese de que la línea de lectura cruza todas las barras y los espacios del símbolo.

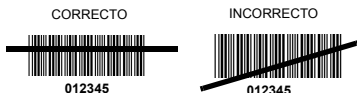

4. Una vez realizada correctamente la decodificación, el scanner emite una señal sonora y el LED se ilumina en color verde.

## Lectura en modo manos libres

Cuando se coloca en su soporte, el scanner está en modo de activación constante. Si se extrae del soporte, el scanner funciona en modo manual normal.

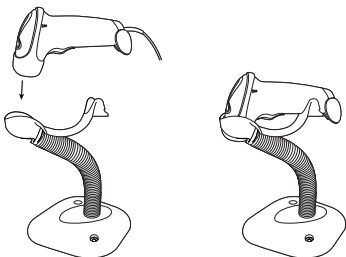

1. Coloque el scanner en su soporte.
2. Exponga el código de barras al scanner y cerciórese de que la línea de lectura cruza todas las barras y los espacios del símbolo.
3. Una vez realizada correctamente la decodificación, el scanner emite una señal sonora y el LED se ilumina en color verde.

## Solución de problemas

Problema	Posibles causas	Posibles soluciones
No ocurre nada cuando sigo las instrucciones de funcionamiento.	El scanner no recibe alimentación.	Compruebe la alimentación del sistema. Cerciérese de que la fuente de alimentación está conectada, en caso de que su configuración requiera una fuente de alimentación.
	Los cables de interfaz/alimentación están sueltos.	Compruebe si hay algún cable suelto.
El láser se enciende, pero el símbolo no se decodifica.	El scanner no está programado para aceptar el tipo de código de barras que desea leer.	Cerciérese de que el scanner está programado para aceptar el tipo de código de barras que quiere leer .
	El símbolo del código de barras es ilegible.	Cerciérese de que el símbolo no está dañado. Intente leer símbolos de prueba del mismo tipo de código de barras.
	La distancia entre el scanner y el código de barras no es la adecuada.	Acerque o aleje el scanner del código de barras, según sea necesario.

# R e f e r e n c i a r á p i d a

<b>Problema</b>	<b>Posibles causas</b>	<b>Posibles soluciones</b>
El símbolo se decodifica, pero no se transmite al host.	El scanner no está programado para el tipo de host que está utilizando.	Realice una lectura de un código de barras apropiado para el tipo de host que utiliza.
Los datos leídos no aparecen correctamente en el host.	El scanner no está programado para funcionar con el host.	<p>Asegúrese de que ha seleccionado el host adecuado.                      Compruebe los parámetros o las opciones de edición de host del scanner.                      Para RS-232, asegúrese de que los parámetros de comunicación del scanner se corresponden con los ajustes del host.</p> <p>Para una configuración de emulación de teclado, compruebe que el sistema está programado para el tipo de teclado correcto y que la tecla CAPS LOCK (Bloq Mayús) está desactivada.</p> <p>Cerciórese de que las opciones de edición (p. ej., conversión de UPC-E a UPC-A) están programadas correctamente.</p>



## **Introdução**

O scanner LS 2208 combina excelente desempenho de leitura e ergonomia avançada para oferecer a melhor relação custo-benefício em um scanner a laser. Quer seja utilizado como um scanner manual ou no modo sem o uso das mãos, em um suporte, o scanner LS 2208 é fácil de usar e confortável, mesmo por longos períodos de tempo.

# R e f e r ê n c i a

## Partes do scanner

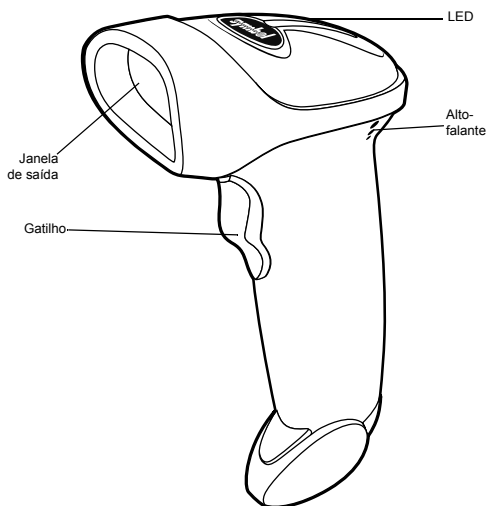

## Instalando o cabo de interface

1. Plugue o conector modular do cabo de interface à porta de interface do cabo, na parte inferior da alça do scanner.

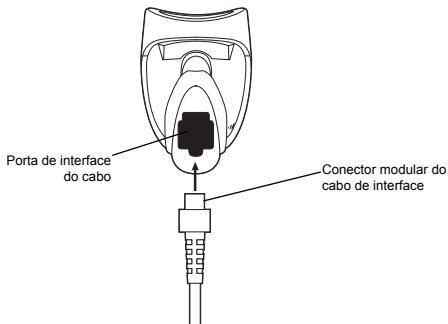

2. Conecte a outra extremidade do cabo de interface ao host.
3. Conecte a fonte de alimentação ao cabo (se necessário).
4. Leia os códigos de barras adequados, a partir da página 65, para se comunicar com o host.



## Removendo o cabo de interface

Retire o conector modular do cabo instalado pressionando a presilha do conector com a ponta de uma chave de fenda.

## Direcionamento

Nota: O scanner apresenta um melhor desempenho quando não está exatamente perpendicular ao código de barras.

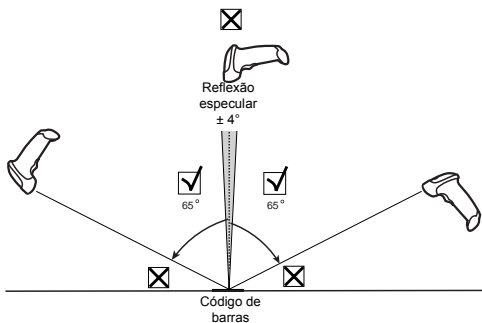

## Leitura no modo manual

1. Verifique se todas as conexões estão firmes.
2. Direcione o scanner para o código de barras.

L S 2 2 0 8



3. Verifique se a linha de leitura cruza todos os espaços e barras do símbolo.



4. Quando o scanner emitir um sinal sonoro e o LED ficar verde, isso indica que a decodificação foi concluída com êxito.

## Leitura no modo sem o uso das mãos

No suporte, o scanner está no modo de ativação constante. Ao ser removido do suporte, ele passa a funcionar no modo manual normal.

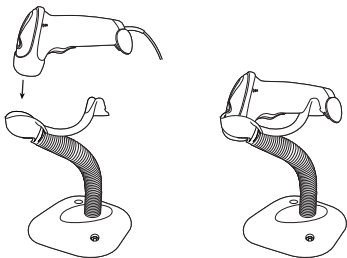

1. Coloque o scanner no suporte.

## R e f e r ê n c i a

2. Apresente o código de barras e verifique se a linha de leitura cruza todos os espaços e barras do símbolo.
3. Quando o scanner emitir um sinal sonoro e o LED ficar verde, isso indica que a decodificação foi concluída com êxito.

## Solução de problemas

Problema	Causa possível	Soluções possíveis
Nada acontece quando você segue as instruções de operação.	O scanner está sem alimentação.	Verifique a alimentação do sistema. Caso a sua configuração exija uma fonte de alimentação, verifique se ela está conectada.
	Os cabos de interface/alimentação estão frouxos.	Verifique se as conexões do cabo estão frouxas.
O laser liga, mas o código de barras não é decodificado.	O scanner não está programado para o tipo de código de barras correto.	Verifique se o scanner está programado para ler o tipo de código de barras que está sendo lido.
	O símbolo do código de barras está ilegível.	Verifique o símbolo para certificar-se de que não esteja apagado. Tente ler outros símbolos de teste com o mesmo tipo de código de barras.
	A distância entre o scanner e o código de barras está incorreta.	Aproxime ou afaste o scanner do código de barras.
O símbolo foi decodificado, mas não foi transmitido para o host.	O scanner não está programado para o tipo de host correto.	Leia o código de barras do tipo de host adequado.

# R e f e r ê n c i a

<b>Problema</b>	<b>Causa possível</b>	<b>Soluções possíveis</b>
Os dados lidos são exibidos no host de forma incorreta.	O scanner não está programado para trabalhar com o host.	<p>Verifique se o host correto está selecionado.</p> <p>Verifique as opções de edição ou os parâmetros de tipo de host do scanner.</p> <p>Para o RS-232, certifique-se de que os parâmetros de comunicação do scanner correspondam às configurações do host.</p> <p>Para uma configuração de emulação de teclado, verifique se o sistema está programado para o tipo de teclado correto e se a tecla CAPS LOCK está desativada.</p> <p>Verifique se as opções de edição (por exemplo, conversão UPC-E para UPC-A) estão programadas corretamente.</p>

# LS 2208

## はじめに

The LS 2208 スキャナは、優れたスキャン性能と先進の人間工学的設計を兼ね備えた、最高品質の軽量レーザスキャナです。LS 2208 スキャナは、ハンドヘルドモードまたはスタンドを使ってハンズフリーモードで使用することができます。操作が簡単で使い勝手が良く、未永くお使いいただけます。

# ク イ ッ ク リ フ ァ レ ン ス

## 各部の名称

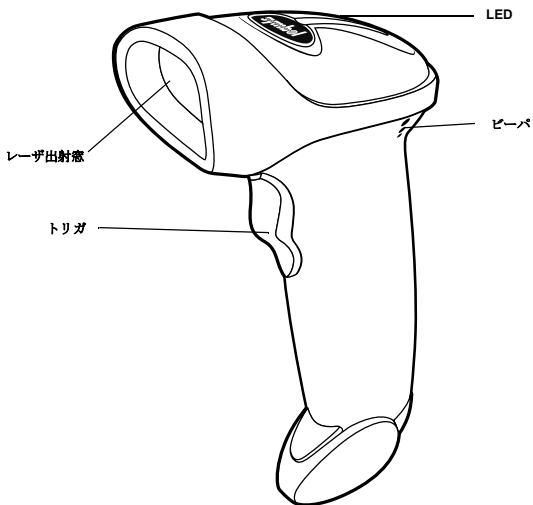

## インタフェースケーブルを取り付ける

1. インタフェースケーブルのモジュラコネクタをスキャナハンドルの底面にあるケーブルインタフェースポートに差し込みます。

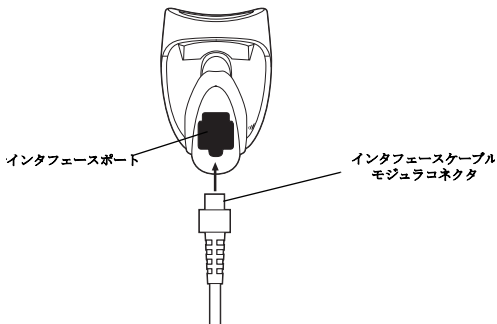

2. インタフェースケーブルのもう片方の端をホストに接続します。
3. ケーブルを電源に接続します (スキャナに電源が必要な場合)。
4. 65 ページ以降に記載されているバーコードメニューをスキャンして、ホストとの通信を設定します。

## インタフェースケーブルを取り外す

ドライバの先端などを使ってコネクタクリップを押し、ケーブルのモジュラコネクタを抜きます。



# ク イ ッ ク リ フ ァ レ ン ス

## 読み取り操作のポイント

注： スキャナをバーコードに直角に向けず  
に、出射角度を少しずらすと、最も読み  
取り性能が高くなります。

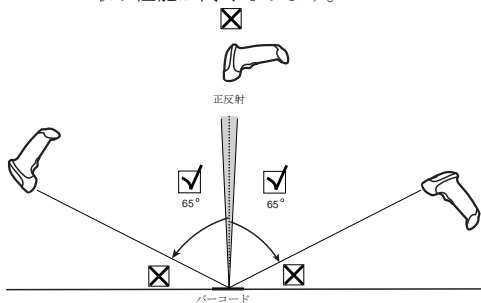

## ハンドヘルドモードでのスキャン

1. 接続がすべて正しく行われていることを確かめます。
2. スキャナをバーコードに向けます。
3. スキャンラインは、バーコード全体を横切るようにスキャンしてください。



4. バーコードを読み取ると、ビープ音が鳴り、LEDが緑色に点灯します。

## ハンズフリーモードでのスキャン

スキャナをスタンドに取り付けている間は、常にハンズフリーモードの状態です。スキャナをスタンドから取り外すと、ハンドヘルドモードに切り替わります。

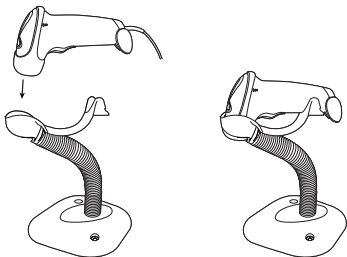

1. スキャナをスタンドに取り付けます。
2. スキャンラインがバーコード全体を横切るように、バーコードをかざします。
3. バーコードを読み取ると、ビープ音が鳴り、LEDが緑色に点灯します。

# ク イ ッ ク リ フ ァ レ ン ス

## トラブルシューティング

症状	考えられる原因	解決方法の例
説明どおりに操作しているが、全く動作しない。	スキャナの電源が入っていない。	装置の電源が入っているか確かめてください。電源に接続する必要があるスキャナの場合、電源に接続されているか確かめてください。
	インタフェース / 電源ケーブルが外れたり緩んでいる。	ケーブルが外れたり緩んでいないか確かめてください。
レーザは出射するが、バーコードを読み取れない。	そのバーコードタイプの読み取りがスキャナにプログラムされていない。	スキャンするバーコードタイプの読み取りがスキャナにプログラムされているか確かめてください。
	バーコードの不良が原因で読み取れない。	バーコードに欠陥がないか確かめてください。同じタイプの他のバーコードをスキャンしてみてください。
	スキャナとバーコードの距離が不適當。	スキャナをバーコードに近づけるか遠ざけてください。
バーコードを読み取っても、ホストにデータ送信されない。	接続しているホストタイプが、スキャナに正しく設定されていない。	バーコードメニューを使って、正しいホストタイプを設定してください。

# LS2208

症状	考えられる原因	解決方法の例
<p>読み取ったデータがホストで正しく表示されません。</p>	<p>スキャナがホストで正常に動作するように設定されていない。</p>	<p>ホストタイプが正しく設定されていることを確かめてください。 スキャナのホストタイプのパラメータまたは編集オプションが正しく設定されているか確かめてください。 RS-232 の場合、スキャナの通信パラメータが POS 端末の設定と一致しているか確かめてください。</p> <p>キーボードウェッジで接続している場合、キーボードタイプが正しく設定され、CAPS LOCK キー がオフになっていることを確かめてください。</p> <p>編集オプション (UPCE から UPCA に変換など) が正しくプログラムされているか確かめてください。</p>

## 快 速 查 询

### 简介

LS 2208 扫描器组合了高性能扫描和高级的人机工程学优点，为轻便型扫描器增添了价值。无论手持或放在支架上作免提扫描器使用，LS 2208 保证使用简便和轻巧舒适。

L S 2 2 0 8

## 扫描器部件

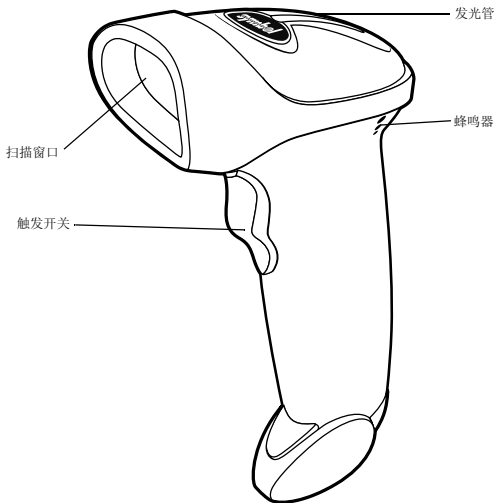

## 快速查询

### 安装接口电缆

1. 将接口电缆方型连接器插入扫描器柄底部的电缆接口端口。

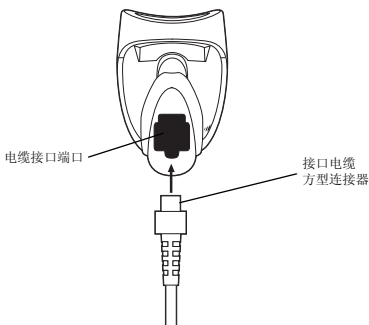

2. 将接口电缆的另一端连接到主机。
3. 将电缆接至电源 (如有必要)。
4. 从第65页开始对相应条码进行扫描, 以与主机通讯。

### 拆除接口电缆

用螺丝刀头按住连接器夹子, 拔出已插入的电缆方型连接器。

L S 2 2 0 8

## 瞄准

注：扫描器与条码不完全垂直时扫描效果最佳。

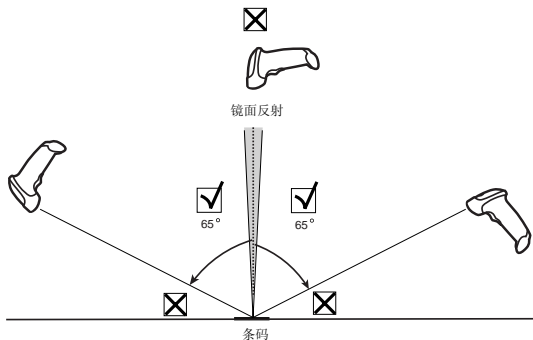

## 以手持模式扫描

1. 请确保所有连接的牢固。
2. 将扫描器对准条码。
3. 请确保扫描线扫过符号的所有条形及空格。

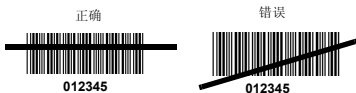

4. 成功解码后，扫描器会发出蜂鸣声且发光管发出绿光。



### 以免提模式扫描

当置于支架上时，扫描器处于固定模式。若将扫描器从支架上移开，它将以正常的手持模式运行。

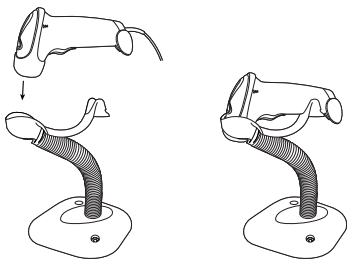

1. 将扫描器放入支架。
2. 瞄准条码，确保扫描线扫过符号的所有条形及空格。
3. 成功解码后，扫描器会发出蜂鸣声且发光管发出绿光。

## 疑难解答

问题	可能原因	可能的解决办法
如果遵循操作说明，扫描器无任何反应。	扫描器未接通电源。	检查系统电源。如果扫描器配置需要电源，则应确保已连接完毕。
	接口 / 电源电缆松动。	检查电缆连接是否松动。
激光出现但符号未解码。	没有将扫描器编程为适用于该条码类型的程序。	确保已将扫描器编程为能够读取待扫描条码类型。
	条码符号不可读。	检查符号以确保其未受损伤。试着扫描相同条码类型的测试符号。
	扫描器与条码的距离不合适。	将扫描器从条码移近或移远。
符号解码完成，但未传至主机。	没有将扫描器编程为适用于该主机类型的程序。	扫描相应的主机类型条码。

## 快速查询

问题	可能原因	可能的解决办法
扫描数据在主机上显示有误。	没有将扫描器编程为能与主机协同工作的程序。	<p>请确保选择了正确的主机。检查扫描器主机类型参数或编辑选项。对于 RS-232, 应确保扫描器的通讯参数与主机设置相匹配。</p> <p>对于键盘仿真配置, 应确保为系统编制了适用于键盘类型的程序, 并且 CAPS LOCK 键处于关闭状态。</p> <p>确保为编辑选项 (例如, 从 UPC-E 到 UPC-A 的转换) 正确编制了程序。</p>



## 소개

LS 2208 조 스캐너는 우수한 스캔 성능과 첨단 인체 공학을 결합하여 경량 레이저 스캐너의 가치를 한 단계 높였습니다. 핸드헬드 스캐너로 사용할 수 있음과 동시에 사용자 요구에 따라 핸즈프리 모드로 사용 가능하여 LS 2208 조 스캐너는 오랜 시간 동안 편리하게 사용할 수 있습니다.

## 스캐너의 구성 부품

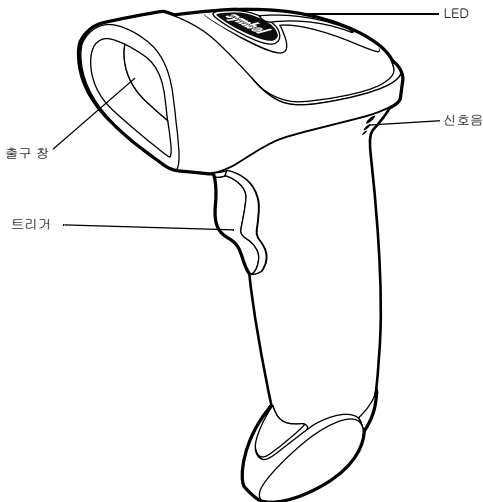

## 인터페이스 케이블 설치

1. 인터페이스 케이블 커넥터를 스캐너의 손잡이 아래쪽에 있는 케이블 인터페이스 포트에 꽂으십시오.

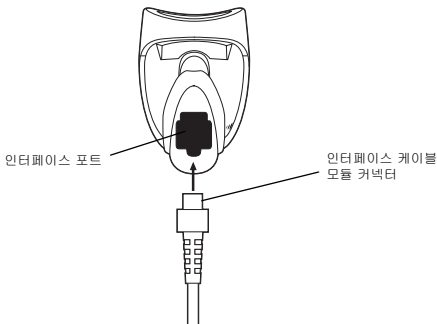

2. 인터페이스 케이블의 다른 쪽 끝을 호스트에 연결하십시오.
3. 전원 공급 장치를 케이블에 연결하십시오 (필요할 경우).
4. 65 페이지부터 시작되는 바코드 중에서 해당 바코드를 스캔하여 호스트와의 통신을 설정하십시오.

## 인터페이스 케이블 제거

드라이버 끝으로 커넥터 클립을 누르고 설치된 케이블의 모듈 커넥터를 빼십시오.

# 요 약 설 명 서

## 조준

참고 : 스캔 성능은 스캐너를 바코드에 정확하게 수직으로 맞추지 않을 경우가 가장 좋습니다 .

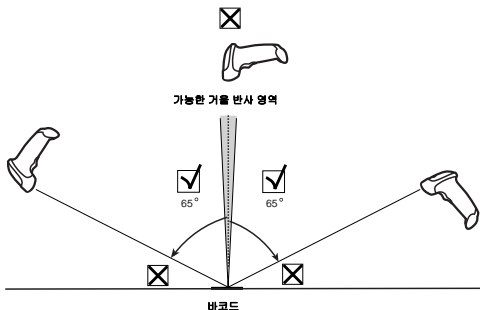

## 핸드헬드 모드 스캔 작업

1. 모든 연결이 안전한지 확인하십시오 .
2. 스캐너를 바코드에 대십시오 .
3. 스캔 라인이 바코드 기호의 모든 바와 공백에 걸쳐 표시되도록 하십시오 .



- 성공적으로 디코딩되면 스캐너에서 삐 소리가 나고 LED가 녹색으로 바뀝니다.

## 핸즈프리 모드 스캔 작업

받침대에 올려 놓으면 스캐너가 고정 모드로 작동하고 받침대에서 스캐너를 빼면 일반적인 핸드헬드 모드로 작동합니다.

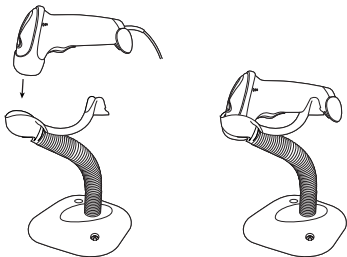

- 스캐너를 받침대에 고정시키십시오.
- 스캔 라인이 바코드 기호의 모든 바와 공백에 걸쳐 표시되도록 바코드를 대십시오.
- 성공적으로 디코딩되면 스캐너에서 삐 소리가 나고 LED가 녹색으로 바뀝니다.



## 요 약 설 명 서

### 문제 해결

문제	문제 발생 원인	해결 방법
설명서의 지시에 따라 작동했는데 아무 변화가 없습니다.	스캐너에 전원이 연결되지 않은 경우.	시스템 전원을 확인하십시오. 전원 공급 장치를 사용하도록 구성한 경우에는 전원 공급 장치가 연결되었는지 확인하십시오.
	인터페이스 / 전원 케이블이 빠진 경우.	연결 케이블이 빠지지 않았는지 확인하십시오.
레이저는 나오는데 기호가 디코딩되지 않습니다.	스캐너에 정확한 바코드 유형이 프로그램되지 않은 경우.	스캔하려는 바코드 유형을 읽을 수 있도록 스캐너를 프로그래밍하십시오.
	바코드 기호를 읽을 수 없는 경우.	바코드 기호가 손상되지 않았는지 확인하십시오. 동일한 유형의 다른 바코드 기호를 스캔해 보십시오.
	스캐너와 바코드 사이의 거리가 맞지 않는 경우.	스캐너를 바코드 가까이 또는 멀리 이동시키십시오.
바코드 기호가 디코딩되지만 호스트에 전송되지 않습니다.	스캐너에 정확한 호스트 유형이 프로그램되지 않은 경우.	해당 호스트 유형 바코드를 스캔하십시오.

# LS2208

문제	문제 발생 원인	해결 방법
<p>스캔한 데이터가 호스트에 정확하게 표시되지 않습니다 .</p>	<p>스캐너가 호스트와 함께 작동하도록 프로그램되지 않은 경우 .</p>	<p>호스트를 정확하게 선택하십시오 .                      스캐너의 호스트 유형 매개변수나 편집 옵션을 확인하십시오 .                      RS-232 의 경우에는 스캐너의 통신 매개변수가 호스트의 설정과 일치해야 합니다 .</p> <p>키보드를 사용하도록 구성한 경우에는 시스템에 정확한 키보드 유형을 프로그램하고 CAPS LOCK 키는 꺼야 합니다 .</p> <p>편집 옵션 ( 예 : UPC-E 와 UPC-A 사이의 변환 ) 이 제대로 프로그램되었는지 확인하십시오 .</p>

## Programming Bar Codes

Following are some frequently used programming bar codes.

Note: For additional host types, refer to the *LS 2208 Product Reference Guide*, p/n 72-58808-xx, available on the LS 2208 CD, or on the Symbol Web site, <http://www.symbol.com/manuals>.

### Set Defaults

Scanning this bar code sets all parameters to their default values.



SET DEFAULTS

### Host Type

If you are using a Synapse cable (i.e., part number STlxx-xxxx), the scanner autodetects the Synapse cable you are using, so you do not need to scan bar codes to enable the synapse host.



If you are using a USB interface, the scanner autodetects the USB and defaults to the HID keyboard interface. See page 72 to select the IBM Hand-Held host type. Refer to the *LS 2208 Product Reference Guide*, p/n 72-58808-xx, for additional USB host types.

If you are using Keyboard Wedge, RS-232, Wand Emulation, Undecoded Scanner Emulation, or IBM 46XX, you must select that host type from the following bar codes:

### ***Keyboard Wedge Host Type***



**IBM PC/AT and IBM PC COMPATIBLES**

Q u i c k R e f e r e n c e

***Country Keyboard Types (Country Codes)***



**NORTH AMERICAN**



**FRENCH Windows**



**FRENCH CANADIAN Windows 95/98**

LS 2208



**GERMAN Windows**



**SPANISH Windows**



**ITALIAN Windows**

Q u i c k R e f e r e n c e



**SWEDISH Windows**



**UK ENGLISH Windows**



**JAPANESE Windows**

LS2208



PORTUGUESE-BRAZILIAN Windows

***RS-232 Host Types***



STANDARD RS-232



ICL RS-232



NIXDORF RS-232 MODE A



Q u i c k R e f e r e n c e



**NIXDORF RS-232 MODE B**



**FUJITSU RS-232**



**OPOS/JPOS**

L S 2 2 0 8

QRG

***USB Host Types***



**HID KEYBOARD EMULATION**



**IBM HAND-HELD USB**

***IBM 46XX Host Types***



**PORT 5B**



**PORT 9B**

# Q u i c k R e f e r e n c e

## ***Wand Emulation Host Type***



**SYMBOL WAND**

Many Wand hosts require input as Code 39 data. Scan the following bar codes to enable or disable transmission of data to the Wand host as Code 39 data.



**ENABLE CONVERT TO CODE 39 FOR WAND HOST**



**DISABLE CONVERT TO CODE 39 FOR WAND HOST**

## ***Undecoded Emulation Host Type***

Scan the bar code below to enable the Undecoded Emulation Host.



**ENABLE UNDECODED EMULATION HOST**

# LS 2208

## **Carriage Return/Line Feed**

To append a carriage return/line feed to all transmitted data, scan the following bar codes in the order shown. To cancel this operation, scan the “Set Defaults” bar code on page 65, or refer to the *LS 2208 Product Reference Guide*.



**SCAN OPTIONS**



**<DATA><SUFFIX>**



**ENTER**

# Q u i c k R e f e r e n c e

## Ergonomic Recommendations

**Caution:** In order to avoid or minimize the potential risk of ergonomic injury follow the recommendations below. Consult with your local Health & Safety Manager to ensure that you are adhering to your company's safety programs to prevent employee injury.

- Reduce or eliminate repetitive motion
- Maintain a natural position
- Reduce or eliminate excessive force
- Keep objects that are used frequently within easy reach
- Perform tasks at correct heights
- Reduce or eliminate vibration
- Reduce or eliminate direct pressure
- Provide adjustable workstations
- Provide adequate clearance
- Provide a suitable working environment
- Improve work procedures.

## Regulatory Information

All Symbol devices are designed to be compliant with rules and regulations in locations they are sold and will be labeled as required.

Any changes or modifications to Symbol Technologies equipment, not expressly approved by Symbol Technologies, could void the user's authority to operate the equipment.

## Radio Frequency Interference Requirements



Note: This equipment has been tested and found to comply with the limits for a Class B digital device, pursuant to Part 15 of the FCC rules. These limits are designed to provide reasonable protection against harmful interference in a residential

installation. This equipment generates, uses, and can radiate radio frequency energy and, if not installed and used in accordance with the instruction manual, may cause harmful interference to radio communications. However there is no guarantee that interference will not occur in a particular installation. If the equipment does cause harmful interference to radio or television reception, which can be determined by

turning the equipment off and on, the user is encouraged to try to correct the interference by one or more of the following measures:

- Re-orient or relocate the receiving antenna
- Increase the separation between the equipment and receiver
- Connect the equipment into an outlet on a circuit different from that to which the receiver is connected
- Consult the dealer or an experienced radio/TV technician for help.

## Radio Frequency Interference Requirements - Canada

This Class B digital apparatus complies with Canadian ICES-003.

Cet appareil numérique de la classe B est conforme à la norme NMB-003 du Canada.

## Marking and European Economic Area (EEA)

### Statement of Compliance



Symbol Technologies, Inc., hereby declares that this device is in compliance with all the applicable Directives, 89/336/EEC, 73/23/EEC. A Declaration of Conformity may be obtained from <http://www2.symbol.com/doc/>.

## Laser Devices



Symbol products using lasers comply with US 21CFR1040.10, and IEC825-1:1993, EN60825-1:1994+A11:1996. The laser classification is marked on one of the labels on the product.

Class 1 Laser devices are not considered to be hazardous when used for their intended purpose. The following statement is required to comply with US and international regulations:

**Caution:** Use of controls, adjustments or performance of procedures other than those specified herein may result in hazardous laser light exposure. Class 2 laser scanners use a low power, visible light diode. As with any very bright light source, such as the sun, the user should avoid staring directly into the light beam. Momentary exposure to a Class 2 laser is not known to be harmful.

# Q u i c k R e f e r e n c e

## Scanner Labeling

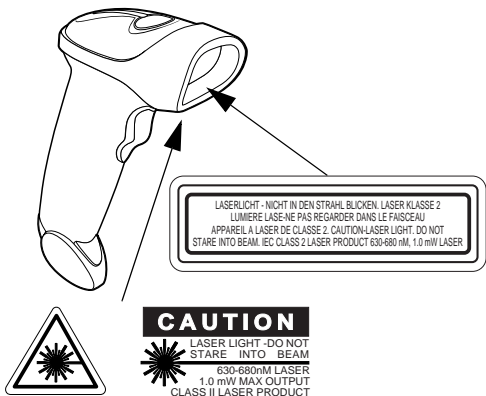

# LS 2208

In accordance with Clause 5, IEC 825 and EN60825, the following information is provided to the user:



**ENGLISH**  
CLASS 1  
CLASS 2

CLASS 1 LASER PRODUCT  
LASER LIGHT  
DO NOT STARE INTO BEAM  
CLASS 2 LASER PRODUCT

**HEBREW**

מוצר לייזר רמה 1  
רמה 1  
אור לייזר  
רמה 2  
אין להביט אל תוך הזרם  
מוצר לייזר רמה 2

**DANISH / DANSK**

KLASSE 1  
KLASSE 2

KLASSE 1 LASERPRODUKT  
LASERLYF  
SE IKKE IND I STRÅLEN  
KLASSE 2 LASERPRODUKT

**ITALIAN / ITALIANO**

CLASSE 1  
CLASSE 2

PRODOTTO AL LASER DI CLASSE 1  
LUCE LASER  
NON FISSARE IL RAGGIOPRODOTTO  
AL LASER DI CLASSE 2

**DUTCH / NEDERLANDS**

KLASSE 1  
KLASSE 2

KLASSE-1 LASERPRODUKT  
LASERLICHT  
NIET IN STRAAL STAREN  
KLASSE-2 LASERPRODUKT

**NORWEGIAN / NORSK**

KLASSE 1  
KLASSE 2

LASERPRODUKT, KLASSE 1  
LASERLYS IKKE STIRR INN I LYSSTRÅLEN  
LASERPRODUKT, KLASSE 2

**FINNISH / SUOMI**

LUOKKA 1  
LUOKKA 2

LUOKKA 1 LASERTUOTE  
LASERVALO  
ÄLÄ TUIJOTA SÄDETTÄ  
LUOKKA 2 LASERTUOTE

**PORTUGUESE / PORTUGUÊS**

CLASSE 1  
CLASSE 2

PRODUTO LASER DA CLASSE 1  
LUZ DE LASER NÃO FIXAR O RAIO LUMINOSO  
PRODUTO LASER DA CLASSE 2

**FRENCH / FRANÇAIS**

CLASSE 1  
CLASSE 2

PRODUIT LASER DE CLASSE 1  
LUMIERE LASER  
NE PAS REGARDER LE RAYON FIXEMENT  
PRODUIT LASER DE CLASSE 2

**SPANISH / ESPAÑOL**

CLASE 1  
CLASE 2

PRODUCTO LASER DE LA CLASE 1  
LUZ LASER  
NO MIRE FIJAMENTE EL HAZ  
PRODUCTO LASER DE LA CLASE 2

**GERMAN / DEUTCH**

KLASSE 1  
KLASSE 2

LASERPRODUKT DER KLASSE 1  
LASERSTRAHLEN  
NICHT DIREKT IN DEN LASERSTRAHL SCHAUEN  
LASERPRODUKT DER KLASSE 2

**SWEDISH / SVENSKA**

KLASS 1  
KLASS 2

LASERPRODUKT KLASS 1  
LASERLJUS STIRRA INTE MOT STRÅLEN  
LASERPRODUKT KLASS 2



# Q u i c k R e f e r e n c e

## Recommandations ergonomiques

Attention : pour éviter ou minimiser le risque potentiel d'une blessure ergonomique, respectez les recommandations suivantes. Consultez votre responsable local de l'hygiène, de la santé et de la sécurité, pour vous assurer que vous respectez les programmes de sécurité de votre entreprise, qui ont pour but d'éviter toute blessure d'employé.

- Réduisez ou éliminez les mouvements répétitifs
- Maintenez une position naturelle
- Réduisez ou éliminez la force excessive
- Conservez à portée de la main les objets fréquemment utilisés
- Effectuez toutes les tâches à une hauteur correcte
- Réduisez ou éliminez les vibrations
- Réduisez ou éliminez la pression directe
- Fournissez des postes de travail réglables
- Prévoyez un dégagement suffisant
- Prévoyez un cadre de travail approprié
- Améliorez les procédures de travail.

## Informations réglementaires

Tous les dispositifs de Symbol sont conçus pour respecter les règles et réglementations dans les lieux où ils sont vendus, et ils sont étiquetés en fonction des besoins.

Tous les changements ou toutes les modifications apportés à l'équipement de Symbol Technologies qui ne sont pas approuvés de façon explicite par Symbol Technologies, risquent de rendre nulle et non avenue l'autorisation accordée à l'utilisateur d'exploiter cet équipement.

## Obligations en ce qui concerne les parasites en radiofréquence



Remarque : cet appareil a été testé et les résultats de ces tests ont révélé qu'il respecte les limites d'un appareil numérique de classe B en conformité avec les règles de la Partie 15 de la FCC. Ces limites sont conçues pour offrir une protection raisonnable contre les parasites dangereux dans une installation résidentielle. Cet appareil produit, utilise et peut rayonner une énergie sous la forme de radiofréquences et, s'il n'est pas installé et employé en conformité avec ces consignes, il peut

provoquer des parasites dangereux au niveau des communications radios. Cependant, il n'y a aucune garantie que des parasites ne vont pas se produire dans une installation particulière. Si cet appareil provoque des parasites dangereux qui affectent la réception d'un poste de radio ou de télévision, ce que vous pouvez déterminer en mettant hors circuit puis en circuit cet appareil, nous encourageons l'utilisateur à essayer de corriger ces parasites en employant au moins l'une des méthodes suivantes :

- Changer l'orientation ou l'emplacement de l'antenne de réception
- Augmenter l'écartement entre cet équipement et le récepteur
- Brancher cet équipement sur la sortie d'un circuit différent de celui sur lequel le récepteur est branché
- Consulter le concessionnaire ou un technicien en radio et télévision expérimenté pour obtenir une assistance.

## Obligations en matière d'interférence en radiofréquence - Canada

Cet appareil numérique de la classe B est conforme à la norme canadienne ICES-003.

Cet appareil numérique de la classe B est conforme à la norme NMB-003 du Canada.

## Marquage et zone économique européenne (ZEE)

### Déclaration de conformité



Symbol Technologies, Inc., déclare par la présente que cet appareil est conforme aux obligations essentielles et autres clauses pertinentes des Directives 1999/5/CE, 89/336/CEE et 73/23/CEE. Vous pouvez obtenir une déclaration de conformité en vous adressant à <http://www2.symbol.com/doc/>.

### Appareils lasers



Les appareils Symbol à rayons laser sont conformes à la norme américaine 21CFR1040.10, ainsi qu'aux normes européennes CEI825-1:1993, EN60825-1:1994+A11:1996. La classification des rayons lasers figure sur l'une des étiquettes de l'appareil.

Les appareils à rayons laser de classe 1 ne sont pas considérés comme dangereux, à condition de les utiliser pour les activités prévues. La déclaration suivante est nécessaire pour respecter les réglementations américaines et internationales :

# Q u i c k R e f e r e n c e

Attention : l'utilisation de commandes, réglages ou procédures autres que celles qui sont spécifiées dans ce document, risque d'entraîner une exposition dangereuse à des rayons laser.

Les scanners à rayons laser de classe 2 utilisent une diode lumineuse de faible puissance. Comme c'est le cas avec n'importe quelle source lumineuse très brillante comme, par exemple, le soleil, l'utilisateur doit éviter de regarder directement le faisceau lumineux. Une exposition momentanée à un rayon laser de classe 2 ne présente pas de danger connu.

## Raccomandazioni ergonomiche

Avvertenza: Al fine di evitare o minimizzare il rischio di lesioni ergonomiche, attenersi alle raccomandazioni fornite di seguito. Rivolgersi al Responsabile Salute e sicurezza per verificare la corretta adesione ai programmi di sicurezza aziendali finalizzati alla prevenzione degli infortuni sul lavoro.

- Limitare o eliminare i movimenti ripetitivi
- Mantenere una postura naturale
- Limitare o eliminare i movimenti che richiedono l'applicazione di una forza eccessiva
- Tenere sempre a disposizione gli oggetti usati più frequentemente
- Eseguire attività alle corrette altezze
- Limitare o ridurre le vibrazioni
- Limitare o ridurre la pressione diretta
- Predisporre postazioni di lavoro regolabili
- Predisporre un adeguato spazio libero
- Predisporre un ambiente di lavoro idoneo
- Migliorare le procedure di lavoro.

## Informazioni normative

Tutti i dispositivi Symbol sono stati progettati in modo da garantire la conformità alle norme e ai regolamenti vigenti nei luoghi in cui vengono venduti e verranno etichettati secondo quanto prescritto.

Ogni alterazione o modifica apportata alle apparecchiature Symbol Technologies che non abbia ricevuto l'espressa autorizzazione della società Symbol Technologies può invalidare l'autorizzazione dell'utente all'utilizzo dell'apparecchiatura.

L S 2 2 0 8

## Requisiti in materia di interferenze in radiofrequenza



Nota: Questa apparecchiatura è stata testata ed è risultata conforme ai limiti previsti per un dispositivo digitale in classe B, ai sensi delle norme FCC, parte 15. Questi limiti sono stati fissati allo scopo di garantire una adeguata protezione

contro le interferenze dannose in un impianto di tipo domestico. Questa apparecchiatura genera, sfrutta e può irradiare energia in radiofrequenza e, se non installata e utilizzata secondo le istruzioni, può causare interferenze dannose alle comunicazioni radio. Tuttavia, l'assenza di interferenze in un particolare impianto non può essere garantita. Qualora si riscontri che questa apparecchiatura dia effettivamente luogo a interferenze dannose alla ricezione del segnale radio o televisivo, cosa che può essere accertata accendendo e spegnendo l'apparecchiatura, si invita l'utente a tentare di porre rimedio all'interferenza assumendo una o più delle seguenti azioni correttive:

- riorientare o collocare in un diverso punto l'antenna ricevente;
- aumentare la distanza tra l'apparecchiatura e il ricevitore;
- collegare l'apparecchiatura ad una presa di un circuito diverso da quello a cui è collegato il ricevitore;
- richiedere l'assistenza del rivenditore o di un tecnico radio/TV qualificato.

## Radio Frequency Interference Requirements - Canada

This Class B digital apparatus complies with Canadian ICES-003.

Cet appareil numérique de la classe B est conforme à la norme NMB-003 du Canada.

## Marcatura nell'Area Economica Europea (AEE)

### Dichiarazione di conformità



Symbol Technologies, Inc., dichiara che questo dispositivo è conforme a tutte le Direttive applicabili 89/336/CEE, 73/23/CEE. Una Dichiarazione di conformità può essere scaricata dal sito <http://www2.symbol.com/doc/>.

### Dispositivi laser



I dispositivi Symbol con funzionamento al laser sono conformi alle norme US 21CFR1040.10 e IEC825-1:1993, EN60825-1:1994+A11:1996. La classificazione laser è riportata su una delle etichette apposte sul dispositivo.

# Q u i c k R e f e r e n c e

I dispositivi laser in classe 1 non sono considerati pericolosi quando utilizzati per gli scopi previsti. La seguente dichiarazione è necessaria per conformare il dispositivo alle regolamentazioni statunitensi e internazionali:

**Avvertenza:** Qualsiasi operazione di comando, regolazione o esecuzione di procedure non espressamente prevista in questo documento può determinare una pericolosa esposizione alla luce laser.

I lettori laser in classe 2 sfruttano un diodo luminoso visibile a bassa potenza. Come con qualsiasi altra sorgente luminosa particolarmente brillante, come la luce solare, l'utente dovrà evitare di fissare direttamente il fascio luminoso. L'esposizione momentanea ad un laser in classe 2 non è considerata dannosa.

## **Ergonomische Empfehlungen**

**Vorsicht:** Die folgenden Empfehlungen sollten beachtet werden, um potenzielle Gesundheitsbeschwerden am Arbeitsplatz zu vermeiden oder zu minimieren. Wenden Sie sich an Ihren Gesundheits- und Sicherheitsbeauftragten vor Ort, um sicherzustellen, dass Sie mit den Sicherheitsvorschriften Ihres Unternehmens vertraut sind, die dem Schutz von Mitarbeitern am Arbeitsplatz dienen.

- Einseitige, sich ständig wiederholende Bewegungen sollten vermieden oder reduziert werden
- Es sollte auf eine geeignete Körperhaltung geachtet werden
- Größere Körperkräfte sollten vermieden oder reduziert werden
- Gegenstände, die häufig verwendet werden, müssen im funktionellen Greifraum liegen
- Die Arbeitshöhe soll der Körpergröße und der Art der Arbeit angepasst sein
- Gegenstände müssen schwingungsfrei aufgestellt werden
- Wenn starke Muskelkräfte eingesetzt werden müssen, ist eine geeignete Körperhaltung zu ermöglichen und für Abstützungen zu sorgen, damit der Kraftweg durch den Körper kurz und einfach gehalten wird
- Tische und Sitze sollten verstellbar sein
- Für Körperbewegungen soll ausreichend Raum vorgesehen sein
- Es sollte ein geeignetes Arbeitsumfeld geschaffen werden
- Arbeitsabläufe sollten optimiert werden.

## Regulatorische Informationen

Alle Symbol-Geräte sind so konstruiert, dass sie die Normen und Richtlinien der Länder erfüllen, in denen sie verkauft werden. Außerdem werden alle Symbol-Geräte je nach Land mit den erforderlichen Prüfzeichen versehen und entsprechend der Bestimmungen des Landes beschriftet.

Jegliche Änderungen an Geräten von Symbol Technologies, die nicht ausdrücklich von Symbol Technologies genehmigt wurden, könnten dazu führen, dass dem Benutzer die Erlaubnis für den Gebrauch des Geräts entzogen wird.

## Forderungen für Hochfrequenzstörungen



Hinweis: Dieses Gerät wurde geprüft und erfüllt die Grenzwerte für ein digitales Gerät der Klasse B laut Teil 15 der FCC-Richtlinien. Diese Grenzwerte wurden aufgestellt, um einen angemessenen Schutz vor Störungen zu

garantieren, wenn das Gerät in einer Wohngegend eingesetzt wird. Dieses Gerät erzeugt, verwendet und kann unter Umständen Funkfrequenzen aussenden und kann sich, sofern es nicht gemäß der Bedienungsanleitung angeschlossen und eingesetzt wird, störend auf anderen Funkfrequenzen auswirken. Eine Garantie, dass bei einer bestimmten Installation keine Störungen auftreten, kann nicht gegeben werden. Sollte das Gerät Störungen beim Radio- oder TV-Empfang verursachen, die durch Aus- und Einschalten der Geräte erkannt werden können, sollten die Störungen durch eine oder mehrere der folgenden Maßnahmen behoben werden:

- Neuausrichtung oder Umstellung der Empfangsantenne
- Vergrößerung des Abstands zwischen Gerät und Empfänger
- Anschluss des Geräts an eine andere Steckdose als die, an der der Empfänger angeschlossen ist
- Beratung durch den Händler oder einen Radio-/Fernsehtechniker.

## Radio Frequency Interference Requirements - Canada

This Class B digital apparatus complies with Canadian ICES-003.

Cet appareil numérique de la classe B est conforme à la norme NMB-003 du Canada.

# Q u i c k R e f e r e n c e

## **Zeichen und der europäische Wirtschaftsraum (EWR) Konformitätserklärung**



Symbol Technologies, Inc. erklärt hiermit, dass dieses Gerät alle anwendbaren Richtlinien (89/336/EEC und 73/23/EEC) erfüllt. Eine Konformitätserklärung kann unter <http://www2.symbol.com/doc/> heruntergeladen werden.

## **Lasergерäte**



Symbol-Geräte mit Lasern erfüllen die folgenden Normen und Richtlinien: US 21CFR1040.10, IEC825-1:1993 und EN60825-1:1994+A11:1996. Die Laserklassifizierung ist auf einem der Aufkleber auf dem Gerät angegeben.

Lasergерäte der Klasse 1 werden als ungefährlich eingestuft, sofern sie für ihren vorgesehenen Zweck eingesetzt werden. Die folgende Warnung muss laut US- und internationalen Bestimmungen aufgeführt werden:

Vorsicht: Die Verwendung von Bedienelementen, die Veränderung von Einstellungen oder die Durchführung von Prozeduren, die hier nicht erwähnt sind, können dazu führen, dass Personen gefährlichem Laserlicht ausgesetzt werden.

Laserscanner der Klasse 2 arbeiten mit einer sichtbaren Niedervolt-Lichtdiode. Wie bei jeder hellen Lichtquelle, wie z. B. auch der Sonne, sollte vermieden werden, direkt in den Lichtstrahl zu blicken. Über Gefahren bei einer kurzzeitigen Aussetzung des Laserlichts eines Laserscanners der Klasse 2 ist nichts bekannt.

## **Recomendaciones ergonómicas**

Precaución: para evitar o reducir al mínimo el posible riesgo de lesiones ergonómicas siga estas recomendaciones. Consulte al Director local de Seguridad e Higiene para asegurarse de que cumple los programas de seguridad de su empresa para evitar daños de los empleados.

- Reduzca o elimine movimientos repetitivos
- Mantenga una posición natural
- Reduzca o elimine la fuerza excesiva
- Mantenga cerca de usted los objetos que utilice frecuentemente
- Realice las tareas a la altura adecuada
- Reduzca o elimine las vibraciones
- Reduzca o elimine la presión directa

# LS2208

- Facilite puestos de trabajo adaptables
- Facilite la distancia adecuada
- Facilite un entorno de trabajo adecuado
- Mejore los métodos de trabajo.

## Información sobre normativas

Todos los dispositivos de Symbol están diseñados para cumplir con las reglas y normativas de los lugares donde se venden, y estarán etiquetados según sea necesario.

Cualesquiera cambios o modificaciones de los equipos de Symbol Technologies, que no hayan sido expresamente autorizados por Symbol Technologies, podrán anular el permiso del usuario para utilizarlos.

## Requisitos de interferencias de las radiofrecuencias



·Nota: Se ha comprobado que este equipo cumple las limitaciones de un dispositivo digital de Clase B, de conformidad con la Parte 15 de las normas FCC. Estos

límites están pensados para ofrecer protección razonable contra las interferencias peligrosas en lugares residenciales. Este equipo genera, utiliza y puede radiar frecuencias de radio y si no se instala y utiliza de conformidad con las instrucciones, puede causar interferencias perjudiciales para las comunicaciones de radio. Sin embargo, no hay garantías de que no se produzcan interferencias en determinadas instalaciones. Si este equipo causa interferencias perjudiciales para la recepción de radio o televisión, que se pueden determinar apagando y encendiendo el equipo, se pide a los usuarios que intenten corregir las interferencias con alguna de las siguientes medidas:

- Vuelva a orientar o colocar la antena receptora
- Aumente la separación entre el equipo y el receptor
- Conecte el equipo en una toma de un circuito distinto del que esté conectado el receptor
- Consulte al distribuidor o a un técnico especializado en radio / TV.

## Radio Frequency Interference Requirements - Canada

This Class B digital apparatus complies with Canadian ICES-003.

Cet appareil numérique de la classe B est conforme à la norme NMB-003 du Canada.



## La marca y el Área Económica Europea (AEE)

### Declaración de cumplimiento



Symbol Technologies, Inc. declara por la presente que este dispositivo cumple todas las directivas correspondientes, 89/336/EEC, 73/23/EEC. Se puede obtener una Declaración de Conformidad en <http://www2.symbol.com/doc/>

### Dispositivos láser



Los dispositivos Symbol que utilizan rayos láser cumplen las normas US 21CFR1040.10 e IEC825-1:1993, EN60825-1:1994+A11:1996. La clasificación láser está marcada en una de las etiquetas del dispositivo.

Los dispositivos láser de Clase 1 no se consideran peligrosos cuando se utilizan para la finalidad para la que están pensados. Es necesaria la siguiente declaración para cumplir las normativas de EE.UU. e internacionales:

**Precaución:** El empleo de controles, los ajustes o la realización de los procedimientos de manera distinta a la especificada en este documento pueden tener como consecuencia la exposición peligrosa a los rayos láser.

Los lectores láser de Clase 2 utilizan un diodo de luz visible de baja potencia. Como con cualquier fuente de luz brillante, como la del sol, el usuario deberá evitar mirar fija y directamente al rayo de luz. No se ha demostrado que sea peligrosa la exposición momentánea a un láser de Clase 2.

## Recomendações Ergonómicas

**Cuidado:** A fim de evitar ou minimizar o risco potencial de lesões ergonómicas, observe as recomendações que se seguem. Consulte o seu Gestor de Saúde e Segurança local a fim de se certificar que está a respeitar os programas de segurança da sua empresa para evitar lesões dos funcionários.

- Reduza ou elimine os movimentos repetitivos
- Mantenha uma postura natural
- Reduza ou elimine a força excessiva
- Mantenha os objectos que são utilizados frequentemente num local de fácil acesso

- Execute as tarefas às alturas correctas
- Reduza ou elimine as vibrações
- Reduza ou elimine pressões directas
- Diligencie postos de trabalho ajustáveis
- Diligencie espaços livres adequados
- Diligencie um ambiente de trabalho adequado
- Melhore os procedimentos de trabalho.

## Informação Regulamentar

Todos os dispositivos da Symbol foram concebidos para estar em conformidade com as normas e regulamentações nos locais onde são vendidos e serão rotulados conforme necessário.

Quaisquer alterações ou modificações a equipamento da Symbol Technologies sem o seu expreso consentimento pode anular o direito de utilização do equipamento.

## Alimentação de Energia

Nota: Utilize apenas uma alimentação de energia (50-14000-010) aprovada pela Symbol com uma potência nominal de 5.2 Vdc e um mínimo de 650 A. A alimentação de energia está certificada segundo a norma EN60950 com potências SELV.

Hinweis: Benutzen Sie nur eine Symbol Technologies genehmigt Stromversorgung (50-14000-010) in den Ausgabe: 5.2Vdc und minimum 650mA. Die Stromversorgung ist bescheinigt nach EN60950 mit SELV Ausgaben.

## Requisitos de Interferências por Radiofrequência



Nota: Este dispositivo foi testado e certificado como estando em conformidade com os limites para um dispositivo digital de Classe B, nos termos da Parte 15 das normas da Comissão Federal de Comunicações (FCC) dos EUA. Estes limites

destinam-se a oferecer uma protecção razoável contra interferências prejudiciais numa instalação residencial. Este equipamento gera, utiliza e pode irradiar energia de radiofrequência e, se não for instalado e utilizado de acordo com as instruções, pode causar interferências prejudiciais às comunicações de rádio. No entanto, não há qualquer garantia de que não ocorrerão interferências numa determinada instalação. Se o equipamento causar interferências prejudiciais à recepção de rádio ou televisão, o que

# Q u i c k R e f e r e n c e

pode ser determinado ligando e desligando o aparelho, o utilizador é encorajado a tentar corrigir a interferência empreendendo uma ou mais das seguintes medidas:

- Reorientar ou reposicionar a antena de recepção
- Aumentar a distância entre o equipamento e o receptor
- Ligar o equipamento a uma tomada de alimentação num circuito diferente daquele ao qual o receptor está ligado
- Consultar o vendedor ou um técnico de rádio/TV habilitado.

## Radio Frequency Interference Requirements - Canada

This Class B digital apparatus complies with Canadian ICES-003.

Cet appareil numérique de la classe B est conforme à la norme NMB-003 du Canada.

## Marcação e Área Económica Europeia (AEE)

### Declaração de Conformidade



Pela presente, a Symbol Technologies, Inc. declara que este dispositivo está em conformidade com todas as Directivas aplicáveis, 89/336/EEC, 73/23/EEC. É possível obter uma Declaração de Conformidade em <http://www2.symbol.com/doc/>

### Dispositivos de Laser



Os dispositivos da Symbol que utilizam lasers obedecem às normas US 21CFR1040.10 e IEC825-1:1993, EN60825-1:1994+A11:1996. A classificação de laser está marcada numa das etiquetas no dispositivo.

Os dispositivos Laser de Classe 1 não são considerados perigosos quando utilizados para o seu fim previsto. A declaração seguinte é necessária para cumprimento das normas americanas e internacionais:

**Cuidado:** A utilização de controlos, ajustes ou a realização de procedimentos diferentes daqueles aqui especificados pode resultar em exposição perigosa a luz do laser.

Os exploradores laser de Classe 2 utilizam um díodo de luz visível de baixa energia. Como com qualquer fonte de luz muito intensa, tal como o sol, o utilizador deve evitar olhar directamente para o feixe de luz. Não se conhecem quaisquer efeitos prejudiciais da exposição momentânea a um laser de Classe 2.

## 人間工学関係の推奨事項

**注意：**人身事故の危険を避けるか、またはそのような危険を最小限に抑えるために、次の推奨事項に従ってください。地元の健康・安全マネージャーと相談し、社員の人身事故を防ぐための貴社の安全プログラムを守っていることを確認してください。

- 同じ動きを繰り返すことをできる限り避けてください
- 自然な姿勢を維持してください
- 過剰な力をかけることをできる限り避けてください
- 頻繁に使うものは、届きやすい場所に保管してください
- 正しい高さで作業を行ってください
- 振動をできる限り避けてください
- 直接の圧力をできる限り避けてください
- 調節可能ワークステーションを提供してください
- 十分な間隙を提供してください
- 適切な作業環境を提供してください
- 作業手順を改善してください。

## 法規情報

All Symbol 機器は、販売されている場所の規則・法規に準拠するよう設計されており、必要に沿ったラベルが付きまます。

Symbol Technologies の明示的な承認を受けずに Symbol Technologies 製の装置を変更または改変した場合、ユーザーが装置を使用する許可が無効になることがあります。

### レーザー機器



レーザーを使用している Symbol の機器は、US 21CFR1040.10、及び IEC825-1:1993、EN60825-1:1994+A11:1996 に準拠しています。レーザー種別は、機器のラベルの一つに記されています。種別 1 レーザー機器は、その目的どおりに使用した場合には危険がないとみなされています。次の文は、米国及び国際法規に従うために必要です：

**注意：**本書において指定された以外のコントロール、調節または手順を実行すると、危険なレーザー光線に晒される可能性があります。

## 人体工学建议

**警告：**为避免或减少对人体造成伤害的潜在危险，请遵循以下建议。与您当

# Q u i c k R e f e r e n c e

地的“健康和安全管理人员”协商，确保遵守公司的安全计划以防职工受到伤害。

减少或消除重复的动作

- 保持自然的位置
- 减少或消除过多的强制力
- 保持经常使用的物体在容易得到的范围内
- 在正确的高度执行作业
- 减少或消除振动
- 减少或消除定向压力
- 提供可调节的工作台
- 提供足够的间距
- 提供合适的工作环境
- 改善工作过程。

## 规章信息

所有 Symbol 设备都遵照出售所在地的规章制度设计，并按照规定进行标记。

如果未经过 Symbol Technologies 明确地批准，对 Symbol Technologies 设备进行任何更换或修改，将可能导致取消用户操作此设备的授权。

## 激光设备



设备使用的激光符合 US 21CFR1040.10、IEC825-1:1993 和 EN60825-1:1994+A11:1996。在设备的一个标签上标有激光分类。

第 1 类激光设备用于既定用途时，不存在危险。下列陈述要求符合美国及国际规章：

警告：除此详细说明之外的使用控制、步骤调整或执行，可能导致危险的激光辐射。

第 2 类激光扫描仪使用低功率、可见的发光二极管。与任何非常明亮的光源一样，如太阳，用户应避免直接凝视光线。第 2 类激光瞬间辐射的危害不可知。

## 인간공학적 권고사항

**주의 :** 인적 사고의 잠재적 위험을 방지하거나 최소화하려면 아래의 권고사항을 따르십시오. 회사의 안전 프로그램을 준수하여 종업원의 부상을 방지할 수 있도록 지역의 건강 안전 담당자와 협의하십시오.

- 반복 동작을 줄이거나 없앤다.
- 자연스런 위치를 유지한다.
- 과도한 힘을 줄이거나 없앤다.
- 자주 사용하는 물건은 쉽게 닿는 곳에 놓는다.
- 정확한 높이에서 작업을 수행한다.
- 진동을 줄이거나 없앤다.
- 직접적인 압력을 줄이거나 없앤다.
- 조정 가능한 작업 장소를 제공한다.
- 적절한 거리를 확보한다.
- 알맞은 작업 환경을 제공한다.
- 작업 절차를 개선한다.

## 규제 정보

모든 Symbol 장비는 판매 지역의 규정과 규칙에 부합하도록 설계되었으며 필요 시 표찰이 부착됩니다

Symbol Technologies 의 명확한 승인이 없이 Symbol Technologies 장비를 변경하거나 개조하면 해당 장비에 대한 사용자 운용 권한이 취소될 수 있습니다

## 레이저 장치



레이저를 사용하는 Symbol 장비는 US 21CFR1040.10 과 IEC825-1:1993, EN60825-1:1994+A11:1996 규정을 준수합니다. 레이저 등급은 장비의 표찰 중 하나에 표시됩니다.

1 등급 레이저 장비는 본래의 목적으로 사용 시 위험하지 않은 것으로 간주됩니다. 다음 선언문은 미국 및 국제 규제 표준을 준수하는 데 필수입니다.

**주의 :** 여기에 명시된 항목 이외의 제어 조작, 조정 작업 또는 절차를 사용하면 위험한 레이저 광선에 노출될 수 있습니다.

2등급 레이저 스캐너에서는 저전력 가시광선 다이오드를 사용합니다. 사용자는 태양광선과 같이 아주 밝은 광원의 광선을 직접 쳐다보지 말아야 합니다.

2 등급 레이저에 순간적으로 노출되는 것은 위험하지 않은 것으로 알려져 있습니다.

# Q u i c k R e f e r e n c e

## Warranty

**(A) Warranty** Symbol Technologies (hereafter "Seller") hardware Products are warranted against defects in workmanship and materials for a period of sixty (60) months from the date of shipment and for the life of the product with regard to the Scan Element (consisting of a Flexure mirror assembly and magnet) embedded in the products, unless otherwise provided by Seller in writing, provided the Product remains unmodified and is operated under normal and proper conditions. Warranty provisions and durations on software, integrated installed systems, Product modified or designed to meet specific customer specifications ("Custom Products"), remanufactured products, and reconditioned or upgraded products, shall be as provided in the applicable Product specification in effect at the time of purchase or in the accompanying software license.

**(B) Spare Parts** Spare parts (i.e. parts, components, or subassemblies sold by Seller for use in the service and maintenance of Products) are warranted against defects in workmanship and materials for a period of thirty (30) days from the date of shipment. Spare parts may be new or originate from returned units under the conditions set forth in subsection D below.

**(C) Repair of Symbol-branded hardware** For repairs on Symbol-branded hardware Products under this Agreement, including repairs covered by warranty, the repair services provided are warranted against defects in workmanship and materials on the repaired component of the Product for a period of thirty (30) days from the shipment date of the repaired Product, or until the end of the original warranty period, whichever is longer.

**(D) Product Service** Products may be serviced or manufactured with parts, components, or subassemblies that originate from returned products and that have been tested as meeting applicable specifications for equivalent new material and Products. The sole obligation of Seller for defective hardware Products is limited to repair or replacement (at Seller's option) on a "return to service depot" basis with prior Seller authorization. Customer is responsible for shipment to the Seller and assumes all costs and risks associated with this transportation; return shipment to the Customer will be at Seller's expense. Customer shall be responsible for return shipment charges for product returned where Seller determines there is no defect ("No Defect Found"), or for product returned that Seller determines is not eligible for warranty repair. No charge will be made to Buyer for replacement parts for warranty repairs. Seller is not responsible for any damage to or loss of any software programs, data or removable data storage media, or the restoration or reinstallation of any software programs or data other than the software, if any, installed by Seller during manufacture of the Product.

**(E) Original Warranty Period** Except for the warranty applying solely to the repaired component arising from a repair service as provided in Section C above, the aforementioned provisions do not extend the original warranty period of any Product that had either been repaired or replaced by Seller.

**(F) Warranty Provisions** The above warranty provisions shall not apply to any Product (i) which has been repaired, tampered with, altered or modified, except by Seller's authorized service personnel; (ii) in which the defects or damage to the Product result from normal wear and tear, misuse, negligence, improper storage, water or other liquids, battery leakage, use of parts or accessories not approved or supplied by Symbol, or failure to perform operator handling and scheduled maintenance instructions supplied by Seller; (iii) which has been subjected to unusual physical or electrical stress, abuse, or accident, or forces or exposure beyond normal use within the specified operational and environmental parameters set forth in the applicable Product specification; nor shall the above warranty provisions apply to any expendable or consumable items, such as batteries, supplied with the Product.

EXCEPT FOR THE WARRANTY OF TITLE AND THE EXPRESS WARRANTIES STATED ABOVE, SELLER DISCLAIMS ALL WARRANTIES ON PRODUCTS FURNISHED HEREUNDER INCLUDING ALL IMPLIED WARRANTIES OF MERCHANTABILITY AND FITNESS FOR A PARTICULAR USE. ANY IMPLIED WARRANTIES THAT MAY BE IMPOSED BY LAW ARE LIMITED IN DURATION TO THE LIMITED WARRANTY PERIOD. SOME STATES OR COUNTRIES DO NOT ALLOW A LIMITATION ON HOW LONG AN IMPLIED WARRANTY LASTS OR THE EXCLUSION OR LIMITATION OF INCIDENTAL OR CONSEQUENTIAL DAMAGES FOR CONSUMER PRODUCTS. IN SUCH STATES OR COUNTRIES, FOR SUCH PRODUCTS, SOME EXCLUSIONS OR LIMITATIONS OF THIS LIMITED WARRANTY MAY NOT APPLY.

The stated express warranties are in lieu of all obligations or liabilities on the part of Seller for damages, including but not limited to, special, indirect or consequential damages arising out of or in connection with the use or performance of the Product or service. Seller's liability for damages to Buyer or others resulting from the use of any Product or service furnished hereunder shall in no way exceed the purchase price of said Product or the fair market value of said service, except in instances of injury to persons or property.

# Service Information

Before you use the unit, it must be configured to operate in your facility's network and run your applications.

If you have a problem running your unit or using your equipment, contact your facility's Technical or Systems Support. If there is a problem with the equipment, they will contact the Symbol Support Center:

United States	1-800-653-5350 1-631-738-2400	Canada	905-629-7226
United Kingdom	0800 328 2424	Asia/Pacific	337-6588
Australia	1-800-672-906	Austria/Österreich	1-505-5794-0
Denmark/Danmark	7020-1718	Finland/Suomi	9 5407 580
France	01-40-96-52-21	Germany/Deutschland	6074-49020
Italy/Italia	2-484441	Mexico/México	5-520-1835
Netherlands/Nederland	315-271700	Norway/Norge	+47 2232 4375
South Africa	11-8095311	Spain/España	91 324 40 00 Inside Spain
Sweden/Sverige	84452900		+34 91 324 40 00 Outside Spain
Latin America Sales Support	1-800-347-0178 Inside US +1-954-255-2610 Outside US		
Europe/Mid-East Distributor Operations	Contact local distributor or call +44 118 945 7360		

For the latest version of this guide go to: <http://www.symbol.com/manuals>.



**72-58807-02**  
**Revision A — September 2003**

Symbol Technologies, Inc. One Symbol Plaza Holtsville, NY 11742-1300