

SWISHER OWNER'S/OPERATOR'S MANUAL

E4-S3000 TRIMMER

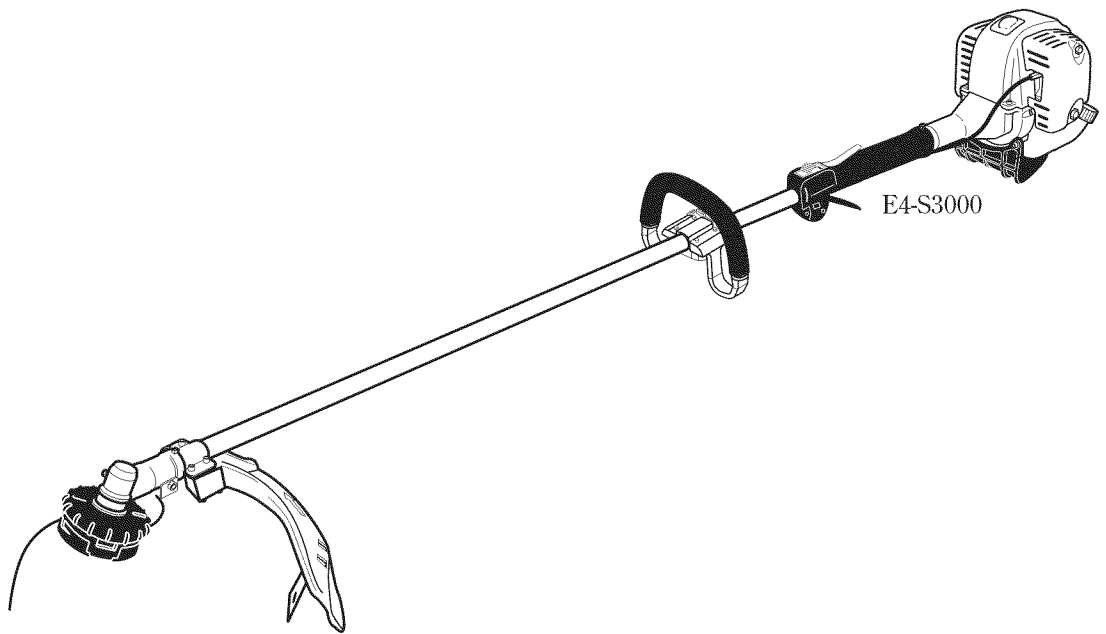

WARNING!

Minimize the risk of injury to yourself and others!
Read this manual and familiarize yourself with the
contents. Always wear eye and hearing protection
when operating this unit.

SWISHER

Part Number 81950 Rev.12/07

Introduction

The Swisher E4-S3000 hand held power equipment has been designed and built to deliver superior performance and reliability without compromise to quality, comfort, safety or durability.

Swisher engines represent the leading edge of high-performance engine technology, delivering exceptionally high power with remarkably low displacement and weight. As an owner/operator, you'll soon discover for yourself why Swisher is simply in a class by itself!

IMPORTANT!

The information contained in this owner's/operator's manual describes units available at the time of publication.

Swisher reserves the right to make changes to products without prior notice, and without obligation to make alterations to units previously manufactured.



WARNING!

The engine exhaust from this product contains chemicals known to the State of California to cause cancer, birth defects or other reproductive harm.

Contents

PAGE

Attention Statements	2
Safety Information.....	3
Safety Labels.....	4
Product Description.....	5
Specifications.....	5
Assembly and Adjustments.....	6
Engine Fuel.....	9
Starting the Engine.....	9
Stopping the Engine	10
Adjusting Engine Idle	10
Checking Unit Condition.....	11
Shoulder Strap.....	11
Cutting Grass with a Trimmer Head	11
Maintenance	12
Long Term Storage.....	15
Troubleshooting Guide	16
Emission System Warranty.....	18

Attention Statements

Throughout this manual are special "attention statements".



WARNING!

A statement preceded by the triangular attention symbol and the word "WARNING" contains information that should be acted upon to prevent serious bodily injury.

CAUTION!

A statement preceded by the word "CAUTION" contains information that should be acted upon to prevent mechanical damage.

IMPORTANT!

A statement preceded by the word "IMPORTANT" is one that possesses special significance.

NOTE:

A statement preceded by the word "NOTE" contains information that is handy to know and may make your job easier.



Read and follow this operators manual. Failure to do so could result in serious injury.



Wear eye and hearing protection at all times during the operation of this unit.



Keep bystanders at least 50 feet (15 m) away during operation.



Beware of thrown or ricocheted objects.



Do not operate this unit with a blade unless the unit is equipped with a Swisher-approved handlebar or barrier.



Always wear a harness when operating this unit with a blade. A harness is also recommended when using trimmer line.



If unit is used as a brushcutter, beware of blade thrust. A jammed blade can cause the unit to jerk suddenly and may cause the operator to lose control of the unit.

IMPORTANT!

The operational procedures described in this manual are intended to help you get the most from this unit as well as to protect you and others from harm. These procedures are guidelines for safe operation under most conditions, and are not intended to replace any safety rules and/or laws that may be in force in your area. If you have questions regarding your E4-S3000, or if you do not understand something in this manual, contact Swisher Inc. at (800) 222-8183, or go to www.swisherinc.com for assistance. You may also contact Swisher at the address printed on the back of this Manual.

General Safety Instructions

Work Safely

Swisher trimmers operate at very high speeds and can do serious damage or injury if they are misused or abused. Never allow a person without training or instruction to operate this unit!



WARNING!

Never make unauthorized attachment installations. Do not use attachments not approved by Swisher for use on this unit.

Stay Alert

You must be physically and mentally fit to operate this unit safely.



WARNING!

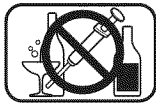

Never operate power equipment of any kind if you are tired or if you are under the influence of alcohol, drugs, medication or any other substance that could affect your ability or judgement.



WARNING! Use Good Judgment

ALWAYS wear eye protection to shield against thrown objects.

NEVER run the engine when transporting the unit.

NEVER run the engine indoors! Make sure there is always good ventilation. Fumes from engine exhaust can cause serious injury or death.

ALWAYS clear your work area of trash or hidden debris that could be thrown back at you or toward a bystander.

ALWAYS use the proper cutting tool for the job.

ALWAYS stop the engine immediately if it suddenly begins to vibrate or shake. Inspect for broken, missing or improperly installed parts or attachments.

NEVER extend trimming line beyond the length specified for your unit.

ALWAYS keep the unit as clean as practical. Keep it free of loose vegetation, mud, etc.

ALWAYS hold the unit firmly with both hands when cutting or trimming, and maintain control at all times.

ALWAYS keep the handles clean.

ALWAYS disconnect the spark plug wire before performing any maintenance work.

The Properly Equipped Operator

Wear close-fitting clothing to protect legs and arms. Gloves offer added protection and are strongly recommended. Do not wear clothing or jewelry that could get caught in machinery or underbrush. Secure hair so it is above shoulder level. NEVER wear shorts!

Wear hearing protection devices and a broad-brimmed hat or helmet.

Always wear eye protection such as goggles or safety glasses.

Always wear a shoulder strap or a harness when operating a unit equipped with a blade.

Always operate with both hands firmly gripping the unit.

Keep away from the rotating trimmer line or blade at all times, and never lift a moving attachment above waist-high.

Keep a proper footing and do not overreach—maintain your balance at all times during operation.

Wear appropriate footwear (non-skid boots or shoes); do not wear open-toed shoes or sandals. Never operate the unit while barefoot!

Always make sure the appropriate cutting attachment shield is correctly installed and in good condition.

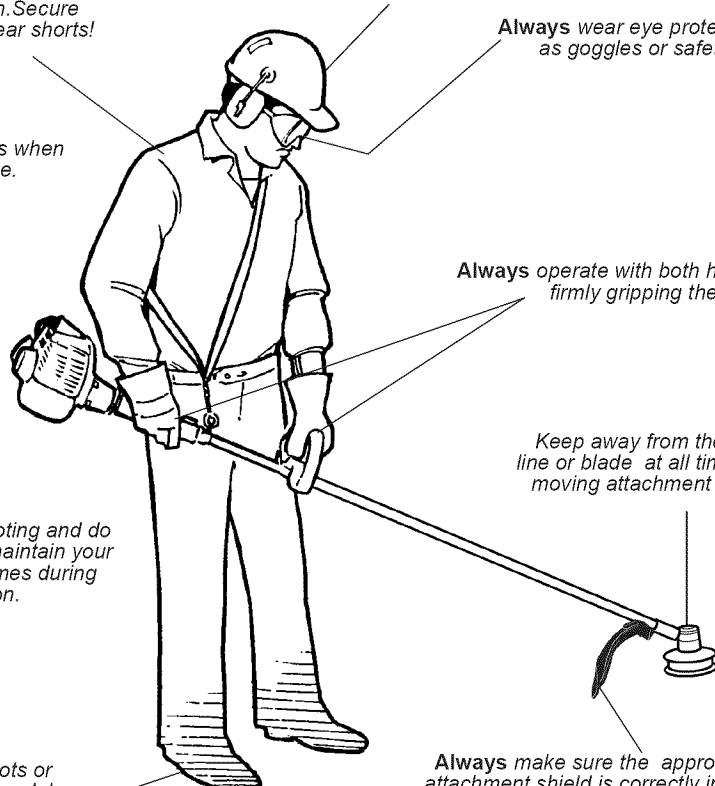
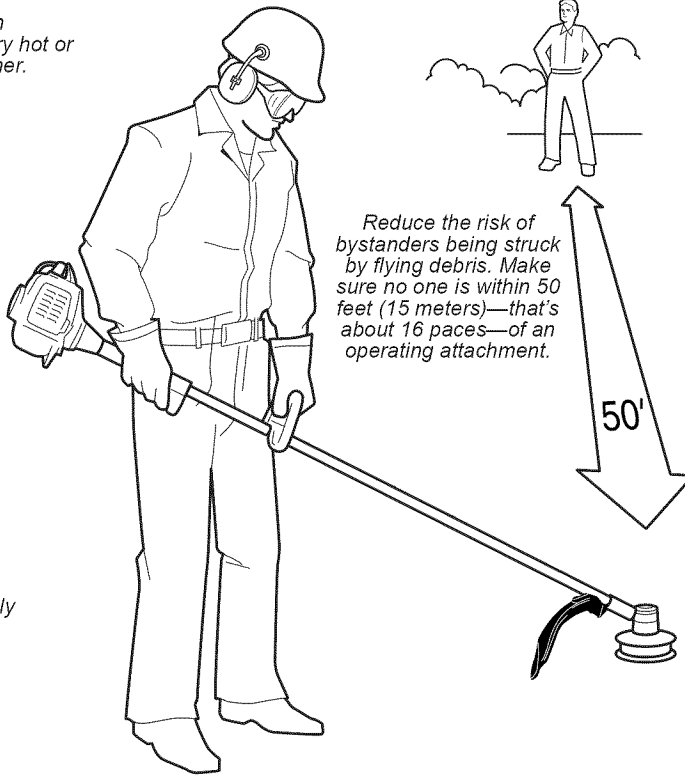

Figure 1

Be Aware of the Working Environment

Avoid long-term operation in very hot or very cold weather.

Make sure bystanders or observers outside the 50-foot "danger zone" wear eye protection.



Reduce the risk of bystanders being struck by flying debris. Make sure no one is within 50 feet (15 meters)—that's about 16 paces—of an operating attachment.

50 FEET

When operating in rocky terrain or near electric wires or fences, use extreme caution to avoid contacting such items with the cutting attachment.

Be extremely careful of slippery terrain, especially during rainy weather.

Always make sure the appropriate cutting attachment shield is correctly installed.

Be constantly alert for objects and debris that could be thrown either from the rotating cutting attachment or bounced from a hard surface.

If contact is made with a hard object, stop the engine and inspect the cutting attachment for damage.

Figure 2

Safety Labels

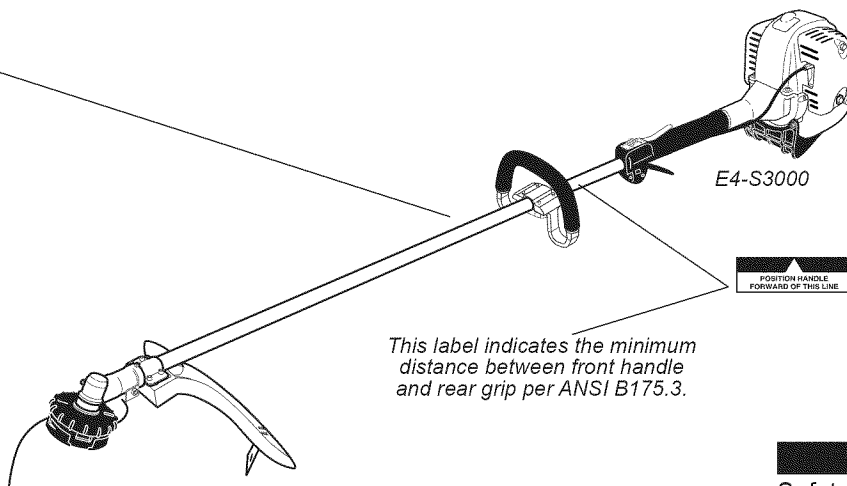

IMPORTANT

Safety and Operation Information Labels: Make sure all information labels are undamaged and readable. Immediately replace damaged or missing information labels. New labels are available, Contact Swisher Inc. at (800) 222-8183, or go to www.swisherinc.com for assistance. You may also contact Swisher at the address printed on the back of this Manual.

Figure 3

Product Description

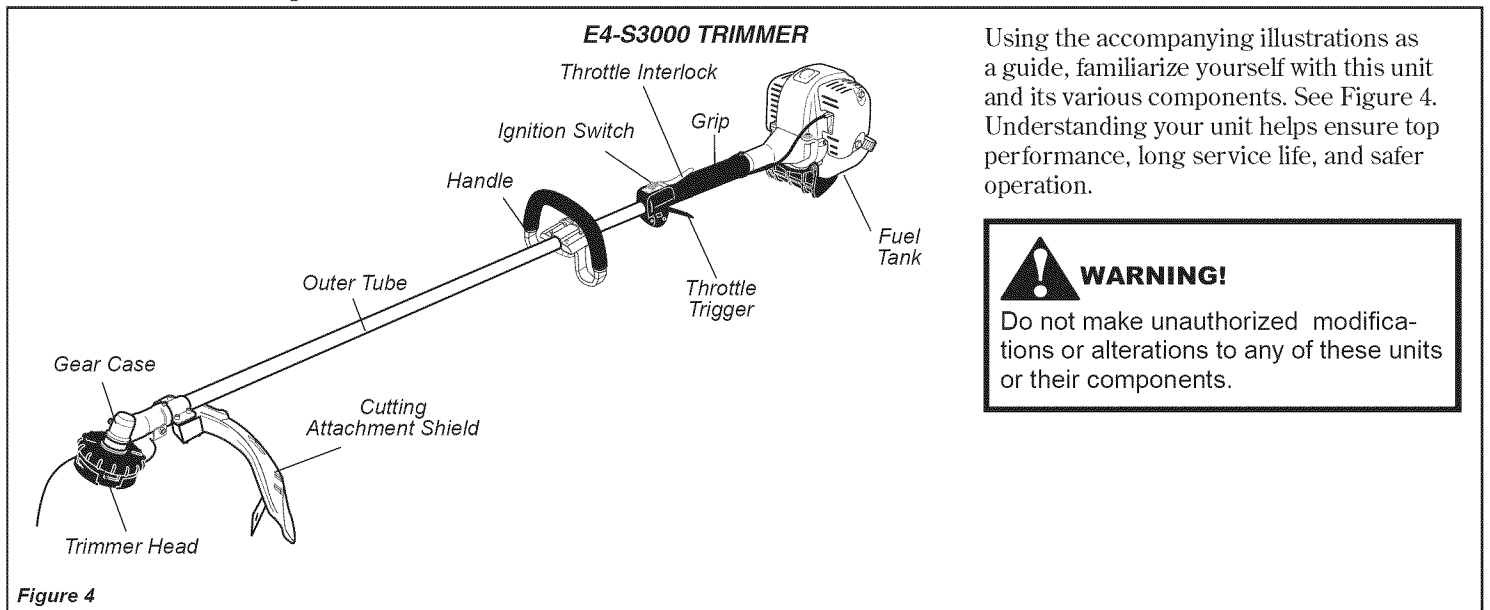

Figure 4

Using the accompanying illustrations as a guide, familiarize yourself with this unit and its various components. See Figure 4. Understanding your unit helps ensure top performance, long service life, and safer operation.

WARNING!

Do not make unauthorized modifications or alterations to any of these units or their components.

Specifications E4-S3000

Dry weight (less attachments)	11.0 lb./5.0 kg	Spark plug	NGK CMR5H
Engine model	SF2510E	Air cleaner type	Non-reversible heavy-duty filter element
Engine type	Power Boost Chamber	Starting method	Recoil
Bore x stroke	1.3 x 1.1 in./34 x27 mm	Stopping method	Slide switch
Displacement	1.5 cu. in./ 24.5 cc	Transmission type	Automatic, centrifugal clutch w/bevel gear
Maximum power	1.1 HP/0.8 kW @ 7500 rpm (min ⁻¹)	EPA Emission Compliance Period**	Category A
Fuel/oil ratio	50:1 with ISO-L-EGD or JASO FC class 2-cycle mixing oil*	** The EPA emission compliance referred to on the emission compliance label located on the engine, indicates the number of operating hours for which the engine has been shown to meet Federal emission requirements. Category C = 50 hours (Moderate), B = 125 hours (Intermediate) and A = 300 hours (Extended).	
Carburetor type	Walbro WYL, diaphragm-type		
Fuel tank capacity	20.3 oz./600 ml		
Ignition	One-piece electronic, program-controlled		

Specifications are subject to change without notice.

Swisher E4 engine oil meets or exceeds these specifications and is recommended for all Swisher products.

This unit comes fully assembled with the exception of the cutting attachment shield and cutting attachment.

Prior to Assembly

Before assembling, make sure you have all the components required for a complete unit and inspect unit and components for any damage.

- Engine and shaft assembly
- Cutting attachment
- Kit containing cutting attachment shield mounting bracket and hardware, this owner's/operator's manual and tool kit for routine maintenance. Tool kits vary by model and may include a hex wrench set, a spark plug/screwdriver combination wrench, and a spanner.

IMPORTANT!

The terms "left", "left-hand", and "LH"; "right", "right-hand", and "RH"; "front" and "rear" refer to directions as viewed by the operator during normal operation.

Assembly and Adjustments

Handle

1. Position the handle on the outer tube as shown. See Figure 3.
2. Install the mounting bracket with the socket head cap screws. Tighten the screws finger-tight ONLY at this time.
3. Locate the handle in the best position for operator comfort (usually about 10 inches ahead of the throttle assembly).
4. Secure the handle by alternately tightening the four socket-head screws in a diagonal or "criss-cross" fashion.

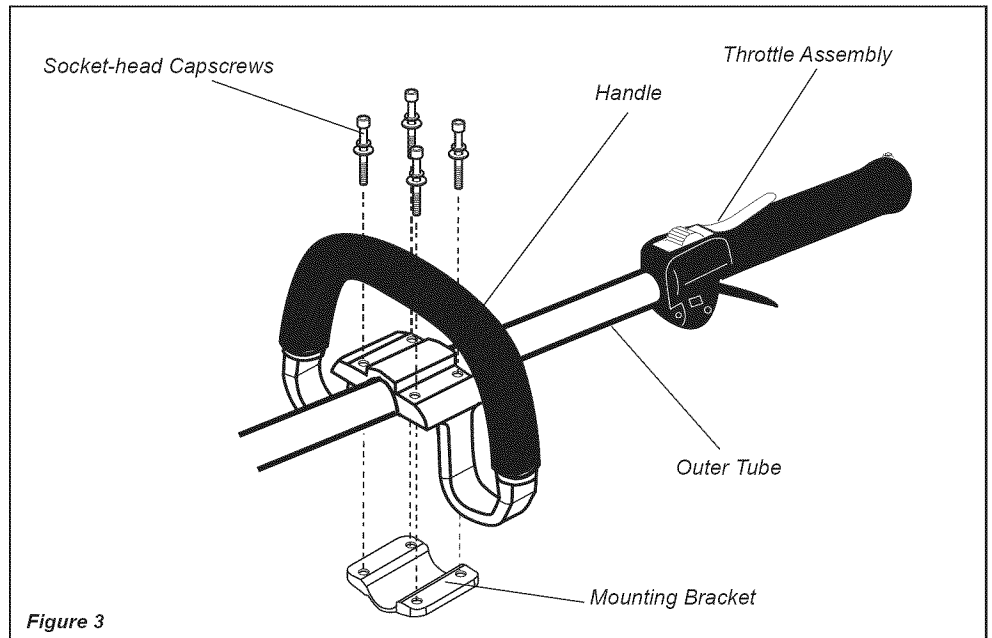

Assembly and Adjustments

Adjust Throttle Lever Free Play E4-S3000

The throttle lever free play should be approximately 3/16-1/4 inch (4-6 mm). See Figure 6. Make sure that the throttle lever operates smoothly without binding. If it becomes necessary to adjust the lever free play, follow the procedures and illustrations that follow.

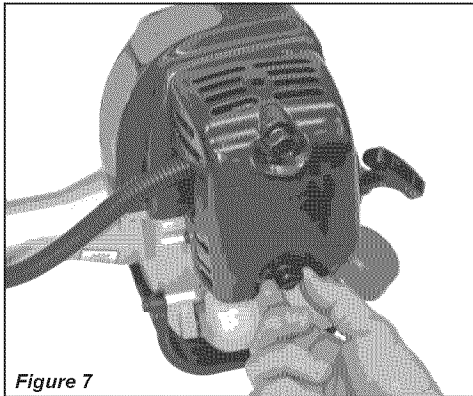
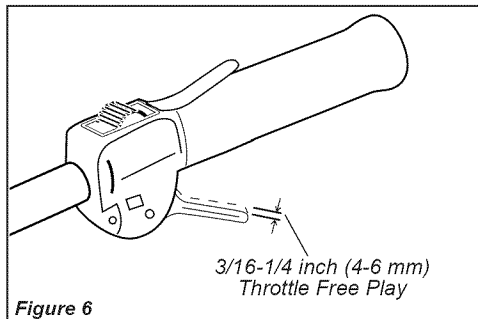

1. Remove the air cleaner cover by loosening the two thumbscrews. See Figure 7.
2. Loosen the lock nut on the cable adjuster. See Figure 8.

3. Turn the cable adjuster in or out as required to obtain proper free play 3/16-1/4 inch (4-6 mm). See Figure 8.
4. Tighten the locknut.

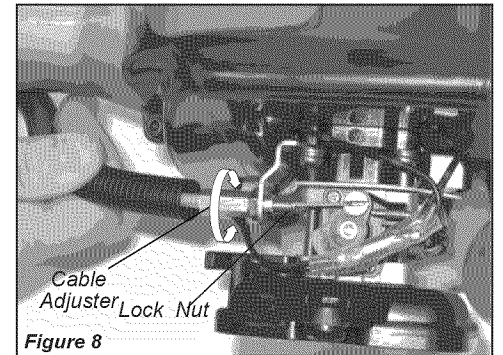

5. Reinstall the air cleaner cover.

Assembly and Adjustments

Cutting Attachment Shield

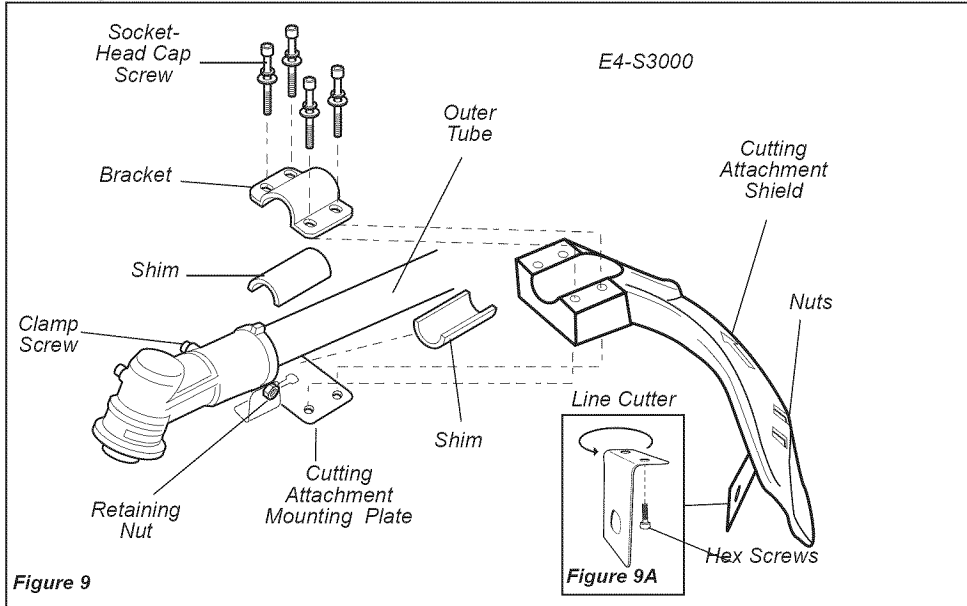

WARNING!
NEVER operate the unit without the cutting attachment shield installed and tightly secured!

CAUTION!
Make sure the clamp screw and retaining nut are securely tightened before tightening the four socket-head cap screws.

Install the Cutting Attachment Shield E4-S3000

1. Insert the cutting attachment shield between the outer tube and the cutting attachment mounting plate. See Figure 9.
2. Fit the two shims and the bracket over the outer tube and loosely install the four socket-head screws. See Figure 9.
3. Tighten the four socket-head cap screws to secure the cutting attachment shield.

NOTE:

It may be necessary to loosen the retaining nut and clamp screw to adjust cutting attachment shield mounting plate.

To Change Position of Line Cutter.

The line cutter can be positioned in 2 positions to obtain different line length for cutting.

1. Remove the 2 hex screws with a 4mm hex wrench. See Figure 9A.
2. Rotate line cutter. See Figure 9A.
3. Reinstall the two hex screws and tighten them securely.

WARNING!
The line cutter is very sharp. Wear gloves to protect your hands when handling.

NOTE:

Be careful to not lose the 2 nuts in the cutting attachment shield, they are not captured.

Install the Trimmer Head



WARNING!

A standard grass trimmer machine should NEVER be operated with blade-type attachments.

1. Turn the trimmer over so that the gearcase output shaft faces UP. See Figure 5.
2. Remove and discard the plastic retaining plug.
3. Position the tool holder as shown, and slide the holder onto the output shaft. See Figure 5.
4. Rotate the tool holder and shaft until the notch in the holder aligns with the notch on the gearcase flange, and use the long end of the hex wrench to lock the output shaft in position. See Figure 6.
5. While holding the hex wrench, thread the trimmer head onto the output shaft, turning counter-clockwise.

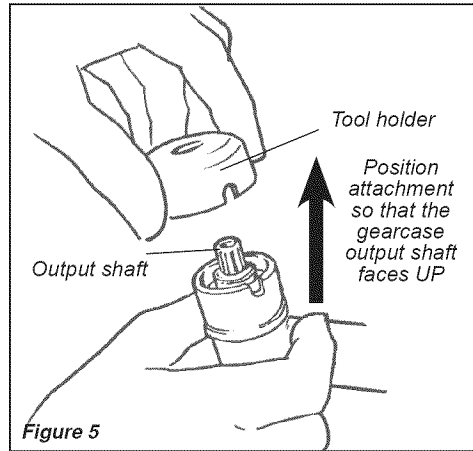

Figure 5

6. Using hand pressure only, tighten the trimmer head firmly on the gearshaft. See Figure 6.
7. Remove the hex wrench.

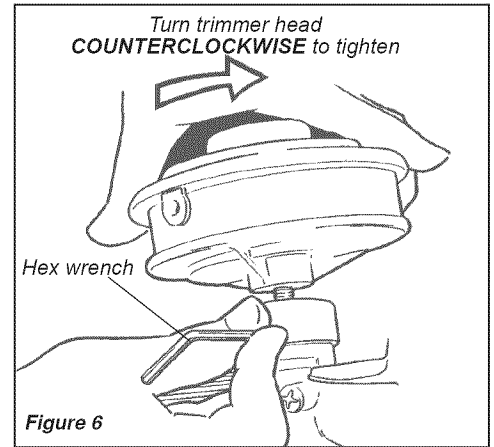

Figure 6

IMPORTANT!

The trimmer head has a left-hand thread. Turn the trimmer head counter-clockwise to install.

Mixing Fuel

CAUTION!

Never use any type of gasoline containing more than 10% alcohol by volume! Some types of gasoline contain alcohol as an oxygenate. Oxygenated gasoline may cause increased operating temperatures. Under certain conditions, alcohol-based gasoline may also reduce the lubricating qualities of some 2-cycle mixing oils. Generic oils and some outboard oils may not be intended for use in high-performance engines, and should never be used in your Swisher engine.

CAUTION!

This engine is designed to operate on a 50:1 mixture consisting of unleaded gasoline and ISO-L-EGD or JASO FC class 2-cycle mixing oil only. Use of non-approved mixing oils can lead to excessive carbon deposits.

- Use only fresh, clean unleaded gasoline with a pump octane of 87 or higher.
- Mix all fuel with a 2-cycle air-cooled mixing oil that meets or exceeds ISO-LEGD and/or JASO FC classified oils at 50:1 gasoline/oil ratio.

Examples of 50:1 mixing quantities

- 1 gallon of gasoline to 2.6 oz. mixing oil
- 5 liters of gasoline to 100 ml. mixing oil

IMPORTANT!

Mix only enough fuel for your immediate needs! If fuel must be stored longer than 30 days and Swisher E4 Engine Oil with fuel stabilizer is not used, it should first be treated with a fuel stabilizer such as STA-BIL™.

Swisher E4 Engine Oil is a registered JASO FC classified oil and also meets or exceeds ISO-L-EGD performance requirements. Swisher E4 engine oil is recommended for use in all Swisher low emissions engines and also includes a fuel stabilizer.

Filling the Fuel Tank



WARNING!

Minimize the Risk of Fire

NEVER smoke or light fires near the engine.

ALWAYS stop the engine and allow it to cool before refueling. Avoid overfilling and wipe off any fuel that may have spilled.

ALWAYS inspect the unit for fuel leaks before each use. During each refill, check that no fuel leaks from around the fuel cap and/or fuel tank.

If fuel leaks are evident, stop using the unit immediately. Fuel leaks must be repaired before using the unit.

ALWAYS move the unit at least 10 feet (3 meters) away from a fuel storage area or other readily flammable materials before starting the engine.

NEVER place flammable material close to the engine muffler.

NEVER operate the engine without the muffler and spark arrester screen in place.

1. Place the trimmer on a flat, level surface.
2. Clear any dirt or other debris from around the fuel filler cap.
3. Remove the fuel cap, and fill the tank with clean, fresh fuel.
4. Reinstall the fuel filler cap and tighten firmly.

Starting the Engine



WARNING!

The cutting attachment may rotate when the engine is started!



WARNING!

Never start the engine without the tool assembly and cutting attachments installed to the engine. Failure to do so could damage the engine and increase unexpected risk to the operator and any bystander.



WARNING!

Never start the engine from the operating position.

IMPORTANT!

Engine ignition is controlled by a two position switch mounted on the throttle housing labeled, "I" for ON or START and "O" for OFF or STOP.

Slide the ignition switch to the "ON" position. See Figure 6.

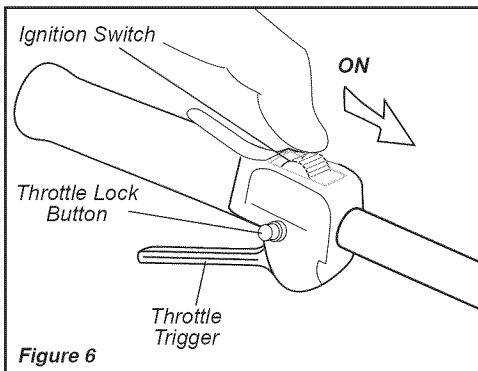

Set the choke lever to the "CLOSED" position if engine is cold.

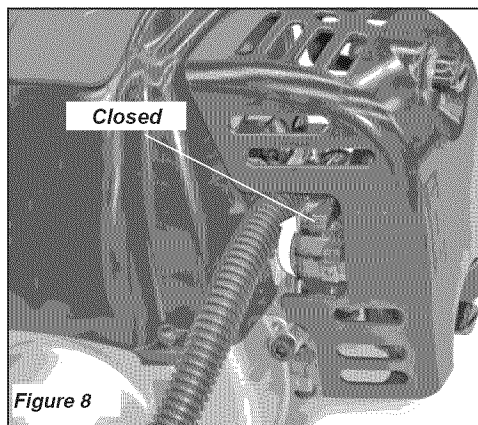

When the engine starts, slowly move the choke lever to the "OPEN" position. See Figure 10. (If the engine stops after the initial start, close the choke and restart.)

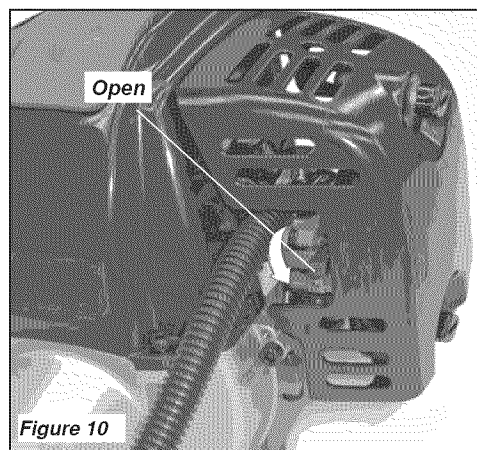

Set the throttle lever to the "fast idle";

Squeeze the throttle lever toward the hand grip on the shaft tube.

Depress and hold the throttle lock button.

While depressing the throttle lock button, release the throttle lever. See Figure 6.

Press the primer bulb until fuel can be seen flowing in the transparent return tube.

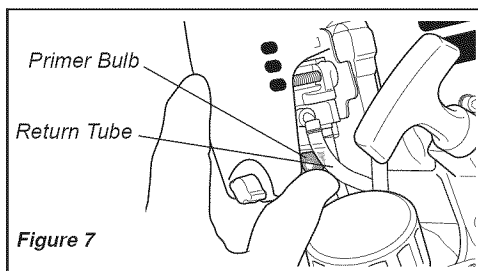

While holding the outer tube firmly with your left hand, use your other hand to slowly pull the recoil starter handle until resistance is felt, then pull quickly to start the engine.

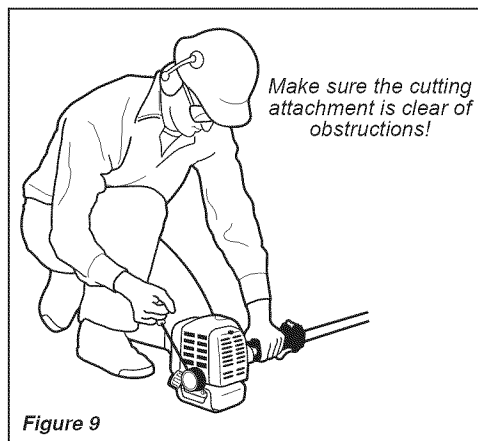

IMPORTANT!

If the engine fails to start after several attempts with the choke in the closed position, the engine may be flooded with fuel. If flooding is suspected, move the choke lever to open position and repeatedly pull the recoil starter to remove the excess fuel and start the engine. If the engine still fails to start, See the section "Starting a Flooded Engine" for instructions.

IMPORTANT!

The primer system only pushes fuel through the carburetor. Repeatedly pressing the primer bulb will not flood the engine with fuel.

CAUTION!

Do not pull the recoil starter to the end of the rope travel. Pulling the recoil starter to the end of the rope travel can damage the starter.

When the Engine Starts...

- After the engine starts, allow the engine to warm up at idle 2 or 3 minutes before operating the unit.
- After the engine is warm, pick up the unit and clip on the shoulder strap.
- Advancing the throttle makes the cutting attachment turn faster; releasing the throttle permits the attachment to stop turning. If the cutting attachment continues to rotate when the engine returns to idle, carburetor idle speed should be adjusted (see "Adjusting Engine Idle").

Stopping the Engine

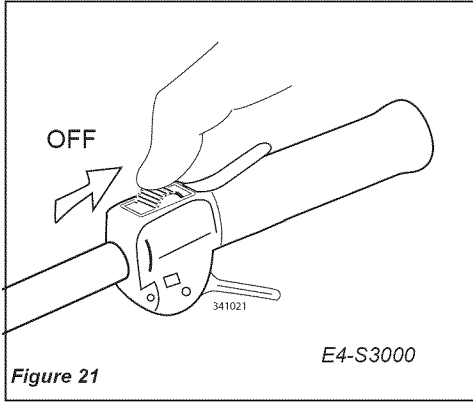

Idle the engine briefly before stopping (about 2 minutes), then slide the ignition switch to the “O” (Engine OFF) position.

Adjusting Engine Idle

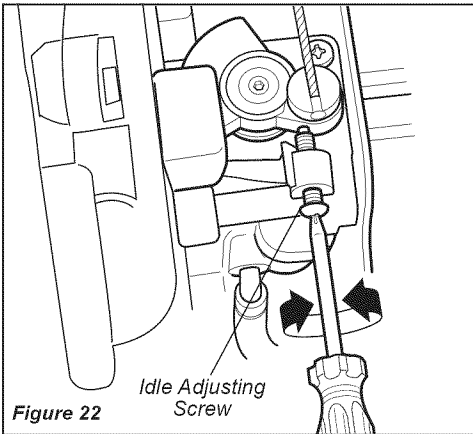

The engine must return to idle speed whenever the throttle lever is released. Idle speed is adjustable, and must be set low enough to permit the engine clutch to disengage the cutting attachment.

Idle Speed Adjustment



WARNING!

The cutting attachment must **NEVER** rotate at engine idle! If the idle speed cannot be adjusted by the procedure described here, return the trimmer to your Swisher dealer for inspection.

1. Place the trimmer on the ground, then start the engine, and then allow it to idle 2-3 minutes until warm.
2. If the attachment rotates when the engine is at idle, reduce the idle speed by turning the idle adjustment screw counter-clockwise. See Figure 22.
3. If a tachometer is available, the engine idle speed should be final adjusted to 3,000 (± 300) RPM (min^{-1}).
4. Carburetor fuel mixture adjustments are preset at factory and cannot be serviced in the field.

Checking Unit Condition

NEVER operate the unit with the cutting attachment shield or other protective devices removed!



WARNING!

A cutting attachment shield or other protective device is no guarantee of protection against ricochet. **YOU MUST ALWAYS GUARD AGAINST FLYING DEBRIS!**

Use only authorized Swisher parts and accessories with your Swisher trimmer. Do not make modifications to this unit without written approval from Swisher, Inc.

ALWAYS make sure the cutting attachment is properly installed and firmly tightened before operation.

NEVER use a cracked or warped cutting attachment: replace it with a serviceable one.

ALWAYS make sure the cutting attachment fits properly into the appropriate attachment holder. If a properly installed attachment vibrates, replace the attachment with new one and re-check.

ALWAYS stop the engine immediately and check for damage if you strike a foreign object or if the unit becomes tangled. Do not operate with broken or damaged equipment.

NEVER allow the engine to run at high RPM without a load. Doing so could damage the engine.

NEVER operate a unit with worn or damaged fasteners or attachment holders.

Shoulder Strap

Operating With A Trimmer Head

NOTE:

Although a shoulder strap accessory is not required for use with a grass trimmer, a shoulder strap can increase operator comfort during extended periods of operation. See Figure 23.

Adjust the shoulder strap so the shoulder pad rests comfortably on the off-side shoulder and the cutting path of the cutting attachment is parallel to the ground. Make sure all hooks and adjustment devices are secure.

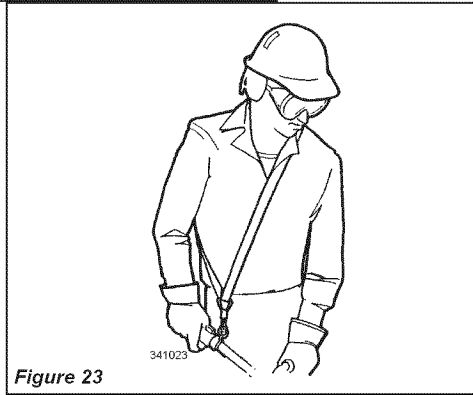

Figure 23

Cutting Grass—Units equipped with a trimmer head

Your Swisher unit may be equipped with one of several Swisher trimmer head models, each with features for specific applications and/or operational requirements.

NOTE:

For proper operation, always refer to the instructions accompanying the trimmer head being used. Available trimmer head styles include:

- **Semi-automatic.** Trimmer line is indexed when the operator taps the trimmer head on the ground during operation.
- **Manual.** The operator indexes line manually with the grass trimmer stopped.
- **Fixed.** The operator must stop the unit and add new lengths of trimmer line manually.
- **Flail.** This device, designed for clearing weeds and light brush, features three nylon blades attached to the head by pivots.

NOTE:

Additional hardware may be required to mount the Fixed Line or the Flail type trimmer heads.

CAUTION!

Do not push the rotating line into trees, wire fences or any material that could tangle or break line ends.

Engine Operating Speeds

Operate the unit at full throttle while cutting grass.

CAUTION!

Operation of trimmer without a cutting attachment shield and using excessive line length can lead to premature clutch failure.

CAUTION!

Operation at low RPM can lead to premature clutch failure.

Hold the trimmer so the trimmer head is angled slightly into the area to be cut. To ensure maximum trimmer-line service life, cut only with the tip of the trimmer line. Cut grass by swinging the trimmer from left to right. Keep the trimmer head horizontal. See Figure 24.

Trimming and Mowing Grass

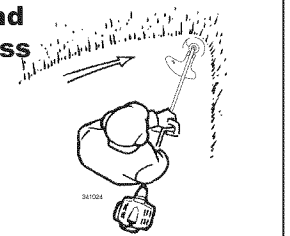

Figure 24

Edging

Tilt the handle about 100° to the left (from horizontal) and move forward, holding the trimmer vertically as shown in Figure 25.

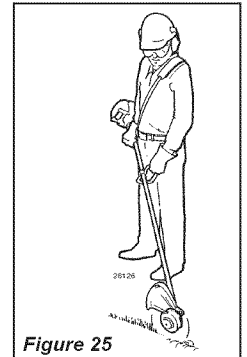

Figure 25

General Maintenance

IMPORTANT!

MAINTENANCE, REPLACEMENT OR RE-PAIR OF EMISSION CONTROL DEVICES AND SYSTEMS MAY BE PERFORMED BY ANY REPAIR ESTABLISHMENT OR INDIVIDUAL; HOWEVER, WARRANTY REPAIRS MUST BE PERFORMED BY A DEALER OR SERVICE CENTER AUTHORIZED BY SWISHER. THE USE OF PARTS THAT ARE NOT EQUIVALENT IN PERFORMANCE AND DURABILITY TO AUTHORIZED PARTS MAY IMPAIR THE EFFECTIVENESS OF THE EMISSION CONTROL SYSTEM AND MAY HAVE A BEARING ON THE OUTCOME OF A WARRANTY CLAIM.



WARNING!

Before performing any maintenance, repair or cleaning work on the unit, make sure the engine and cutting attachment are completely stopped. Disconnect the spark plug wire before performing service or maintenance work.



WARNING!

Non-standard parts may not operate properly with your unit and may cause damage and lead to personal injury.

NOTE:

Using non-standard replacement parts could invalidate your Swisher warranty.

Muffler

This unit must never be operated with a faulty or missing spark arrester or muffler. Make sure the muffler is well secured and in good condition. A worn or damaged muffler is a fire hazard and may also cause hearing loss.

Spark Plug

Keep the spark plug and wire connections tight and clean.

Fasteners

Make sure nuts, bolts, and screws (except carburetor adjusting screws) are tight.

Air Filter

The E4 engine that powers your Swisher model is a hybrid 4-stroke engine. As a hybrid, the engine is lubricated by oil mixed with the gasoline and air from the carburetor that moves through and around the internal parts

of the engine in a similar way that a 2-stroke engine is lubricated. Without the heavy duty 2-stage air filter equipped on all E4 engines, dust and dirt could also move through the engine, decreasing engine life, increasing valve

wear and the need for more frequent valve adjustments. To keep your E4 engine strong and reliable, Swisher recommends that you check and service the air filter as instructed in the 10-Hour Maintenance section that follows.

Daily Maintenance

Prior to each work day, perform the following:

- Remove dirt or debris from the engine, check the cooling fins and air cleaner for clogging and clean them as necessary.

- Carefully remove any accumulation of dirt or debris from the muffler or the fuel tank. Dirt build-up in these areas could cause engine overheating, induce premature wear, or create a fire hazard.

- Check for loose or missing screws or components. Make sure the cutting attachment is securely fastened.
- Check the entire unit for leaking fuel or grease.

10-Hour Maintenance

(more frequently in dusty conditions)

- Remove the air cleaner cover by loosening the two thumbscrews. See Figure 28A.
- Remove and inspect the pre-filter. If the pre-filter is torn or otherwise damaged, replace it with a new one. See Figure 28B.
- Clean the pre-filter with soap and water. Let dry before reinstalling.
- Inspect the air cleaner element. If the element is damaged or distorted, replace it with a new one.
- Tap filter gently on a hard surface to dislodge debris from element or use compressed air from the inside to blow debris out and away from the air cleaner element.

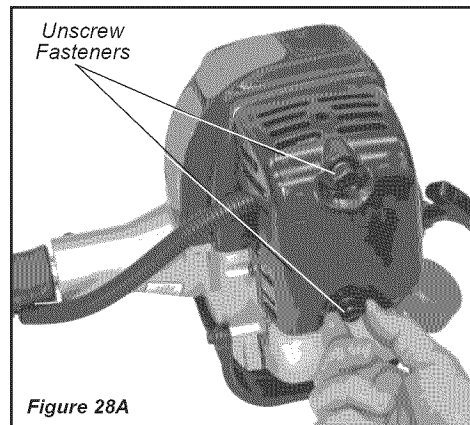

Figure 28A

- Install the air cleaner element, pre-filter and cover in the reverse order of removal.

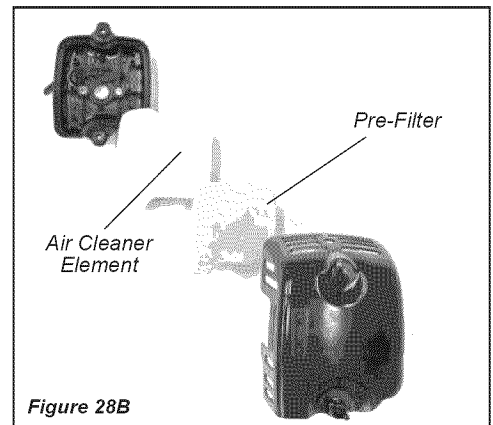

Figure 28B

IMPORTANT!

Direct the air stream at the inside face of the filter only!

CAUTION!

Never operate the unit if the air cleaner assembly is damaged or missing!

10/15-Hour Maintenance

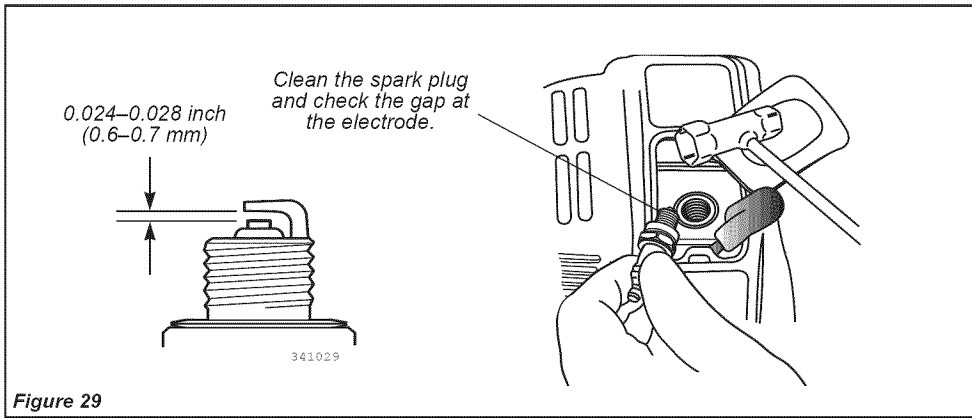

Every 10 to 15 hours of operation:

Remove and clean the spark plug. Adjust the spark plug electrode gap to 0.024 - 0.028 inch (0.6 - 0.7 mm). If the spark plug must be replaced, use only an NGK CMR5H or equivalent resistor type spark plug of the correct heat range. See Figure 29.

NOTE:

The NGK CMR5H also meets the requirements for electro magnetic compliance (EMC).

CAUTION!

Before removing the spark plug, clean the area around the plug to prevent dirt and debris from getting into the engine's internal parts.

50-hour Maintenance

Every 50 hours of operation (more frequently in dusty or dirty conditions):

- Remove and clean the cylinder cover and clean grass and dirt from the cylinder fins.
- Remove the cutting attachment, cutting attachment holder and gear shaft collar. Remove the filler plug from the side of the gear case and press new grease into the gear case until old grease is pushed out. Use only lithium-base grease. See Figure 30.
- Lubricate main shaft splines.
- Use a hooked wire to extract the fuel filter from inside the fuel tank. See Figure 31.

Remove and replace the filter element.

CAUTION!

Make sure you do not pierce the fuel line with the end of the hooked wire. The line is delicate and can be damaged easily.

Before reinstalling the new filter element, inspect the condition of all the fuel system components (fuel pick-up line, fuel return line, tank vent line, tank vent, fuel cap and fuel tank). If damage, splitting or deterioration is noted, the unit should be removed from service until it can be inspected or repaired by a Swisher-trained service technician.

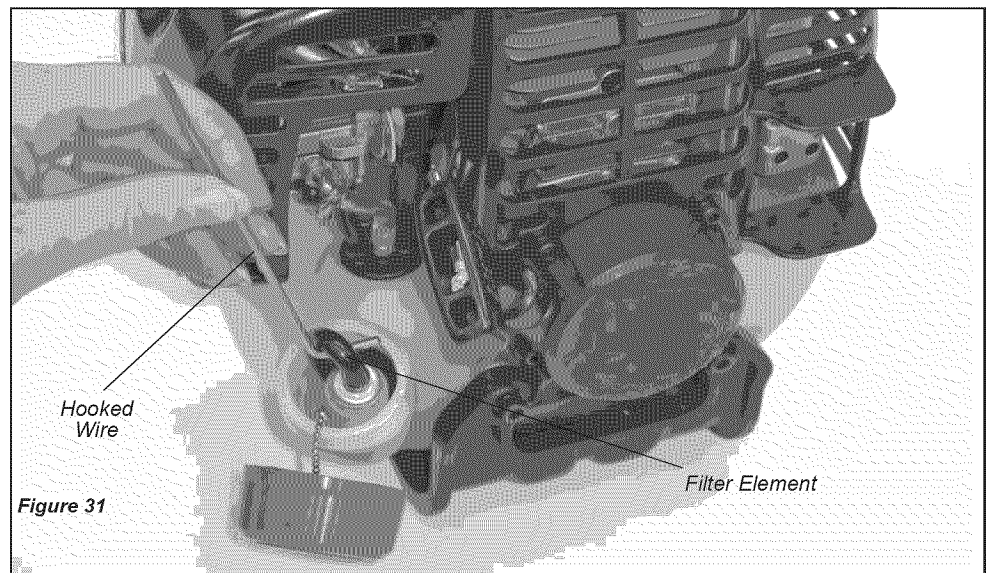
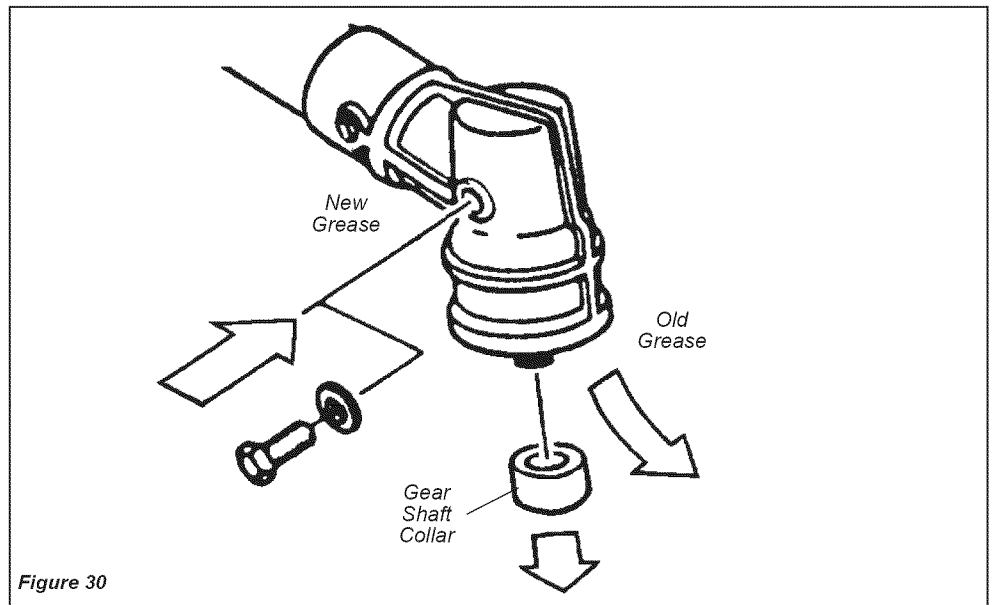

139/150-Hour Maintenance

Maintenance after first 139-hours, then every 150-hours thereafter.

- Combustion chamber should be decarbonized, and the valve clearance should be adjusted. It is highly recommended that this is done by a Swisher-trained service technician.

- Replace the spark plug annually: Use only NGK CMR5H or equivalent resistor type spark plug of the correct heat range. Set spark plug electrode gap to 0.024-0.028 inch (0.6-0.7 mm).

Valve Adjustment

1. Remove cylinder cover, rocker arm cover, and spark plug. Rotate the crankshaft while observing the piston through the spark plug opening. When the piston is at the top of the compression stroke (TDC), the valves can be adjusted.

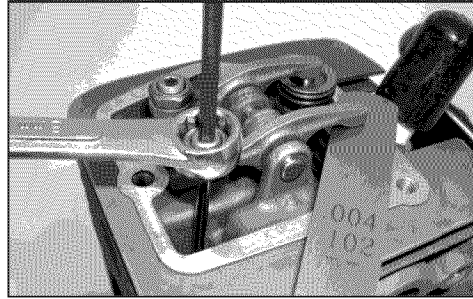

NOTE:
The NGK CMR5H also meets the requirements for electro magnetic compliance (EMC).

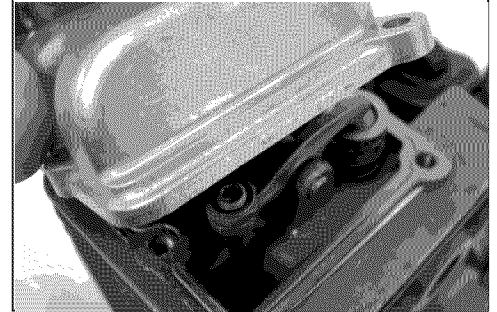

CAUTION!

- Performing a valve adjustment incorrectly may cause hard starting and/or can damage the engine.
- If you are unfamiliar with this engine or uncomfortable with this procedure, consult with an authorized Swisher servicing dealer.

2. Loosen adjuster locknut so that the 2.5 mm Allen socket head adjustment screw can turn freely.
3. Insert 0.10 mm (0.004") feeler gauge between valve stem tip and rocker arm.
4. Turn adjustment screw (clockwise = tighter, counter-clockwise = looser) until feeler gauge is almost snug. Back off just enough to allow gauge to slip out with limited resistance.
5. While holding the adjustment screw in place with the Allen driver, tighten the locknut with a wrench.

6. Turn engine over several times, and return to TDC-compression. Recheck with proper feeler gauge to make sure clearance adjustment did not change as a result of tightening the locknut. Readjust as necessary.
7. Replace rocker arm cover gasket to assure proper sealing and install cover.

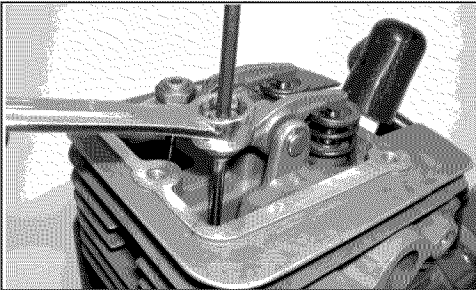

IMPORTANT!
If a new gasket is not available and/or the old gasket is not damaged, the old gasket may be reused. Never use cracked or damaged gaskets!

Spark Arrester Screen Maintenance

If the engine becomes sluggish and low on power, check and clean the spark arrester screen.

WARNING!
Never operate the unit with a damaged or missing muffler or spark arrester! Operating with a missing or damaged spark arrester is a fire hazard and could also damage your hearing.

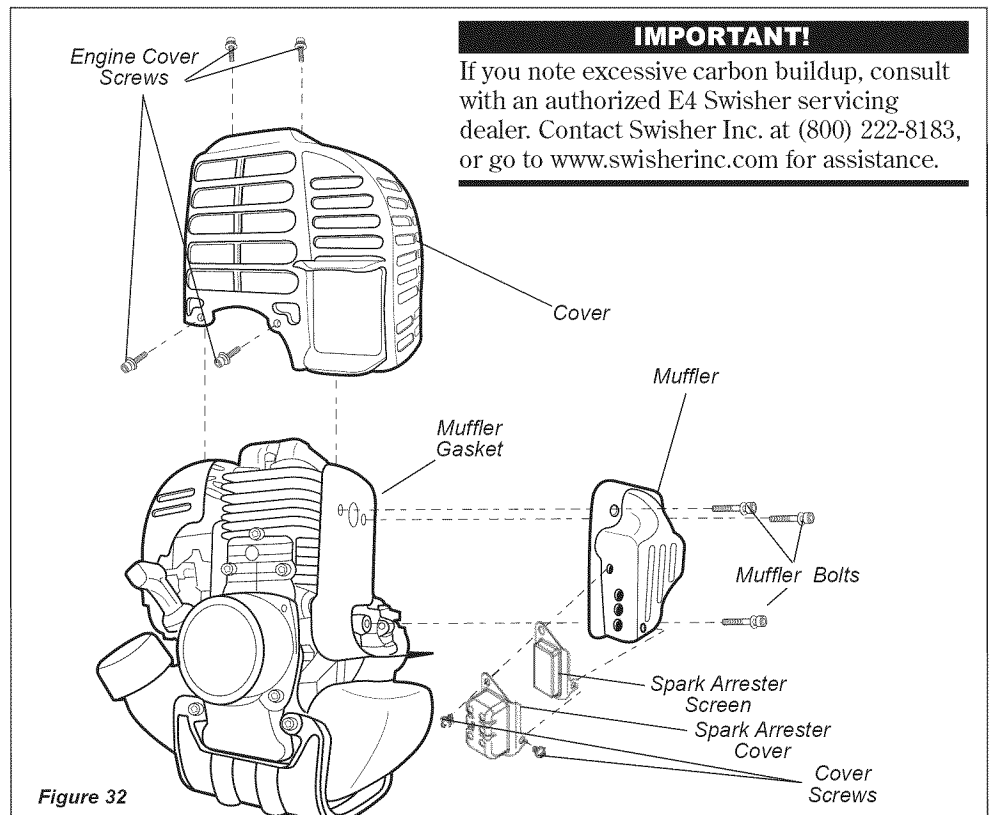

These instructions refer to Figure 32.

1. With a 3 mm hex wrench remove the 3 engine cover screws and the engine cover.
2. With a 4 mm hex wrench remove the 3 muffler bolts and the muffler.
3. With a small flat bladed screwdriver remove the 2 screws holding the spark arrester screen and cover to the muffler.
4. Remove the screen and clean it with a stiff bristle brush.
5. Inspect the cylinder exhaust port for any carbon buildup.
6. Reassemble the spark arrester, muffler and engine cover in the reverse order of disassembly.

Long Term Storage

Whenever the unit will not be used for 30 days or longer, use the following procedures to prepare it for storage:

- Clean external parts thoroughly.
- Drain all the fuel from the fuel tank.

IMPORTANT!

All stored fuels should be stabilized with a fuel stabilizer such as STA-BIL™, if Swisher E4 Engine Oil with fuel stabilizer is not used.

CAUTION!

Gasoline stored in the carburetor for extended periods can cause hard starting and could also lead to increased service and maintenance cost.

- Remove the remaining fuel from the fuel lines and carburetor.
 1. Prime the primer bulb until no more fuel is passing through.
 2. Start and run the engine until it stops running.
 3. Repeat steps 1 and 2 until the engine will no longer start.

- Remove the spark plug and pour about 1/4 ounce of 2-cycle mixing oil into the cylinder through the spark plug hole. Slowly pull the recoil starter 2 or 3 times so oil will evenly coat the interior of the engine. Reinstall the spark plug.
- Before storing the unit, repair or replace any worn or damaged parts.
- Remove the air cleaner element from the carburetor and clean it thoroughly with soap and water. Let dry and reassemble the element.
- Store the unit in a clean, dust-free area.

Speed-Feed® 375 Loading Instructions P/N 78890-28000

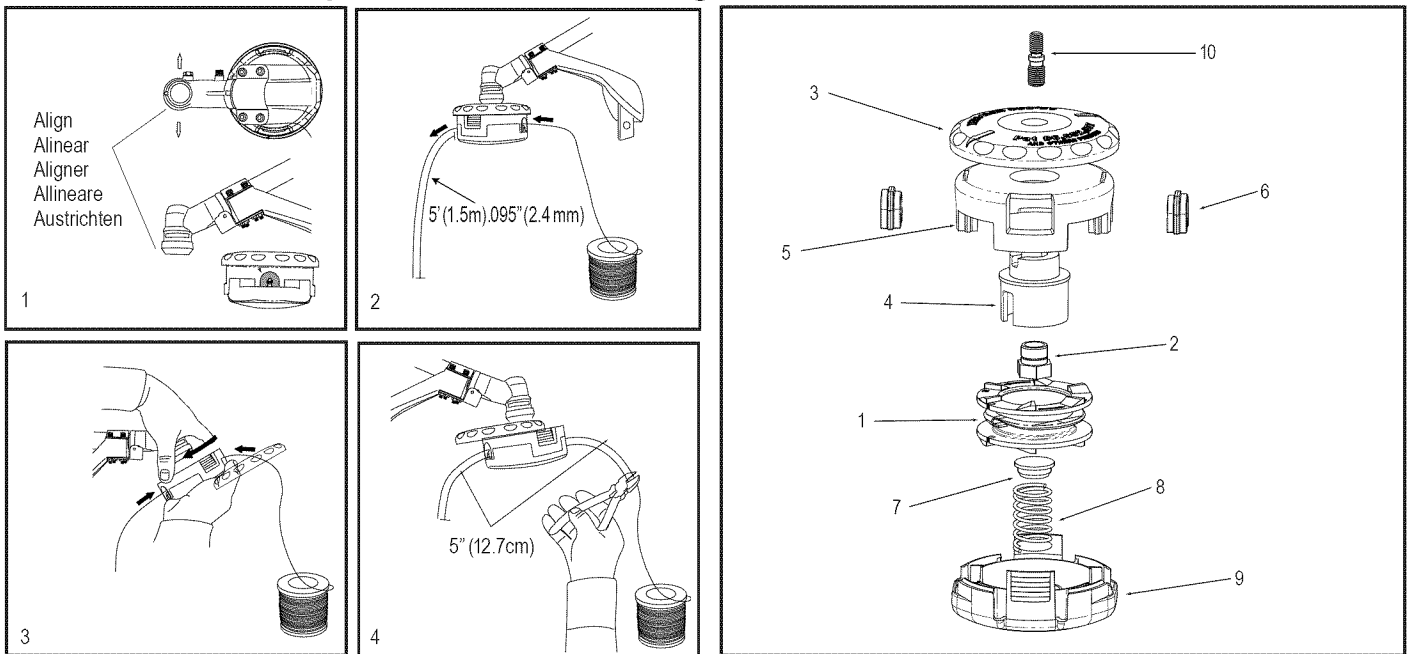

No.	Part Number	Part Name	Descripción	Nom de la pièce	Denominazione	Beschreibung	Qty.
1	78890-11330	SPOOL LH	CARRETE LH	BOBINE LH	BOBINA LH	SPULE LH	1
2	78890-11380	BUSHING	BUJE	BAGUE	BOCCOLA	REDUZIERRING	1
3	78890-11310	KNOB	PERILLA	POIGNEE	MANOPOLA	DREHSCHLEIBE	1
4	28820-07350	CORE	BASE CENTRAL	MOYEU	PARTE INTERNA	KERNSTÜCK	1
5	78890-11320	EYELET CARRIER	SOPORTE DE BOQUILLAS	CORP DE POULIE	SUPPORTO DELL'OCCHIELLO	FENSTERELEMENT	1
6	28820-07340	EYELET	BOQUILLAS	PASSE-CÂBLE	OCCHIELLO	FENSTER	2
7	28820-07380	CAP	TAPA	CAPUCHON	CAPPELLO	VERSCHLUSSAUFBAU	1
8	17500-23600	SPRING	RESORTE	RESSORT	GRUPPO MOLLA	FEDER	1
9	28820-09310	COVER	TAPA	COUVERCLE	COPERCHIO	DECKEL	1
10	78890-25310	STUD, 7 MM LH	PERNO, 7 MM LH	BOULON, 7 MM LH	BULLONE, 7 MM	SCHRAUBBOLZEN, 7 MM	1

Troubleshooting Guide

ENGINE DOES NOT START

What To Check	Possible Cause	Remedy
Does the engine crank?	NO Faulty recoil starter. Fluid in the crankcase. Internal damage.	Consult with an authorized servicing dealer.
YES		
Good compression?	NO Loose spark plug. Excess wear on cylinder, piston, rings. Valves not seating.	Tighten and re-test. Consult with an authorized servicing dealer.
YES		
Does the tank contain fresh fuel of the proper grade?	NO Fuel incorrect, stale or contaminated; mixture incorrect.	Refill with fresh, clean unleaded gasoline with a pump octane of 87 or higher mixed with a 2-cycle air cooled mixing oil that meets or exceeds ISO-L-EGD and/or JASO FC classified oils at 50:1 gasoline/oil ratio.
YES		
Is fuel visible and moving in the return line when priming?	NO Check for clogged fuel filter and/or vent. Priming pump not functioning properly.	Replace fuel filter or vent as required; restart. Consult with an authorized servicing dealer.
YES		
Is there spark at the spark plug wire terminal?	NO The ignition switch is in "O" (OFF) position. Shorted ignition ground. Faulty ignition unit.	Move switch to "I" (ON) position and restart. Consult with an authorized servicing dealer. Consult with an authorized servicing dealer.
YES		
Check the spark plug.	If the plug is wet, excess fuel may be in the cylinder. The plug is fouled or improperly gapped. The plug is damaged internally or of the wrong size.	Crank the engine with the plug removed, reinstall the plug, and restart. Clean and regap the plug to 0.024 - 0.028 inch (0.6 - 0.7 mm). Restart. Replace the plug with an NGK CMR5H or equivalent resistor type spark plug of the correct heat range. Set spark plug electrode gap to 0.024-0.028 inch (0.6-0.7 mm).

LOW POWER OUTPUT

What To Check	Possible Cause	Remedy
Is the engine overheating?	Operator is overworking the unit. Carburetor mixture is too lean. Improper fuel ratio. Fan, fan cover, cylinder fins dirty or damaged. Carbon deposits on the piston or in the muffler.	Shorten trimmer line. Cut at a slower rate. Consult with an authorized servicing dealer. Refill with fresh, clean unleaded gasoline with a pump octane of 87 or higher mixed with a 2-cycle air cooled mixing oil that meets or exceeds ISO-L-EGD and/or JASO FC classified oils at 50:1 gasoline/oil ratio. Clean, repair or replace as necessary. Consult with an authorized servicing dealer.
Engine is rough at all speeds. May also have black smoke and/or unburned fuel at the exhaust.	Clogged air cleaner element. Loose or damaged spark plug. Air leakage or clogged fuel line. Water in the fuel. Piston seizure. Faulty carburetor and/or diaphragm. Valve clearance set incorrectly.	Service the air cleaner element. Tighten or replace. Repair or replace filter and/or fuel line. Replace the fuel. See page 10. Consult with an authorized servicing dealer. Consult with an authorized servicing dealer. Consult with an authorized servicing dealer.
Engine is knocking.	Overheating condition. Improper fuel. Carbon deposits in the combustion chamber. Valve clearance set incorrectly.	See above. Check fuel octane rating; check for presence of alcohol in the fuel (pg. 10). Refuel as necessary. Consult with an authorized servicing dealer. Consult with an authorized servicing dealer.

Troubleshooting Guide (continued)

ADDITIONAL PROBLEMS

Symptom	Possible Cause	Remedy
Poor acceleration.	Clogged air filter. Clogged fuel filter. Lean fuel/air mixture. Idle speed set too low.	Clean the air filter. Replace the fuel filter. Consult with an authorized servicing dealer. Adjust: 3,000 (\pm 300) RPM (min^{-1}).
Engine stops abruptly.	Switch turned off. Fuel tank empty. Clogged fuel filter. Water in the fuel. Shorted spark plug or loose terminal. Ignition failure. Piston seizure.	Reset the switch and restart. Refuel. See page 10. Replace fuel filter. Drain; replace with clean fuel. See page 10. Clean and replace spark plug, tighten the terminal. Replace the ignition unit. Consult with an authorized servicing dealer.
Engine difficult to shut off.	Ground (stop) wire is disconnected or switch is defective. Overheating due to incorrect spark plug. Overheated engine.	Test and replace as required. Idle engine until cool. Clean and regap the plug to 0.024 - 0.028 inch (0.6 - 0.7 mm). Correct plug: NGK CMR5H or equivalent resistor type spark plug of the correct range. Idle engine until cool.
Top of engine is getting dirty and oily.	Valve cover is leaking.	Consult with an authorized servicing dealer.
Cutting attachment rotates at engine idle.	Engine idle too high. Broken clutch spring or worn clutch spring boss. Loose attachment holder.	Set idle: 3,000 (\pm 300) RPM (min^{-1}). Replace spring/shoes as required, check idle speed. Inspect and re-tighten holders securely.
Engine will not idle down.	Engine idle set too high. Engine has an air leak.	Set idle: 3,000 (\pm 300) RPM (min^{-1}). Consult with an authorized servicing dealer.

ADDITIONAL PROBLEMS

Symptom	Possible Cause	Remedy
Excessive vibration.	Warped or damaged cutting attachment. Loose gearcase. Bent main shaft/worn or damaged bushings. Trimmer line not wound properly on spool.	Inspect and replace attachment as required. Tighten gearcase securely. Inspect and replace as necessary. Rewind trimmer line.
Cutting attachment will not rotate.	Shaft not installed in powerhead or gearcase. Broken shaft. Damaged gearcase.	Inspect and reinstall as required. Consult with an authorized servicing dealer. Consult with an authorized servicing dealer.

Emission System Warranty Statement (Administered by Shindaiwa Corporation)

Your Warranty Rights and Obligations

The California Air Resources Board, the U.S. Environmental Protection Agency and Shindaiwa Corporation are pleased to explain the exhaust and evaporative emission control system warranty on your new small off-road (non-road) engine.

In California, new small off-road engines must be designed, built, and equipped to meet the State's stringent anti-smog standards. In other states, new 1997 and later non-road engines must meet the Federal EPA's stringent anti-smog standards. Shindaiwa Corporation must warrant the emission control system on your small off-road engine for the periods of time listed below, provided there has been no abuse, neglect, or improper maintenance of your small off-road engine.

Your engine exhaust and evaporative emission control system includes parts such as the carburetor, fuel tank, the ignition system and, if equipped, the catalytic converter. These components are specifically listed below.

Where a warrantable condition exists, Shindaiwa Corporation will repair your small off-road engine at no cost to you including diagnosis, parts, and labor.

Manufacturer's Warranty Coverage

When sold within the U.S., this engine's emission control system is warranted for a period of two (2) years from the date this product is first delivered to the original retail purchaser.

During the warranty period, Shindaiwa Corporation will, at their option, repair or replace any defective emission-related component on this engine. During the original Warranty Period, these Warranty Rights are automatically transferable to subsequent owners of this product.

What is Covered by this Warranty

1. Carburetor Internal Components
 - Throttle Valve, Needle, Jet, Metering Diaphragm
2. Fuel Tank
3. Ignition System Components
 - Ignition Coil
 - Flywheel Rotor
4. Catalytic Converter (if originally equipped)

The emission control system for your particular Shindaiwa Corporation engine may also include certain related hoses and connectors.

Owners Warranty Responsibilities

As the small off-road engine owner, you are responsible for the performance of the required maintenance listed in this owners manual. Shindaiwa Corporation recommends that you retain all receipts covering maintenance on your small off-road engine, but Shindaiwa Corporation cannot deny warranty solely for the lack of receipts or for your failure to ensure the performance of all scheduled maintenance.

As the small off-road engine owner, you should be aware, however, that Shindaiwa Corporation may deny you warranty coverage if your small off-road engine or a part has failed due to abuse, neglect, improper maintenance, or unapproved modifications.

You are responsible for presenting your small off-road engine to an authorized Shindaiwa Corporation Dealer as soon as a problem exists. The warranty repairs should be completed in a reasonable amount of time, not to exceed 30 days.

If you have any questions regarding your warranty rights and responsibilities, you should contact a Shindaiwa Corporation customer service representative or your local Shindaiwa Dealer.

Consequential Damages

In the event that other component parts of this product are damaged by the failure of a warranted part, Shindaiwa Corporation will repair or replace such component parts at no charge to you.

What is Not Covered

- Failures caused by abuse, neglect, or improper maintenance procedures.
- Failures caused by the use of modified or non-approved parts or attachments.

This Warranty is Administered by:

Shindaiwa Corporation
11975 SW Herman Road
Tualatin, OR 97062
(503) 692-3070

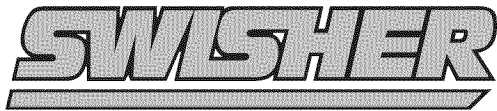

Swisher
P.O. Box 67
Warrensburg, MO 64093

Part Number 81950
Revision 12/2007