

# **PARTS MANUAL**

**Model**

**SGX7500  
GENERATORS**

PUB-EP  
Rev. 03/11



**Industrial Power Products**

Robin America, Inc.

905 Telser Road • Lake Zurich, IL 60047 • Phone: 847-540-7300 • Fax: 847-438-5012  
e-mail: [sales@robinamerica.com](mailto:sales@robinamerica.com) • [www.subarupower.com](http://www.subarupower.com)

© Copyright 2011 Robin America, Inc.

# GROUP INDEX

<b>Group Name</b>	<b>Page</b>
CRANKCASE GROUP .....	4
CRANKSHAFT GROUP .....	8
INTAKE and EXHAUST GROUP .....	10
GOVERNOR GROUP .....	14
COOLING and STARTING GROUP .....	16
FUEL, LUBRICATION GROUP .....	18
ELECTRIC.....	22

FIG. 1 CRANKCASE GROUP

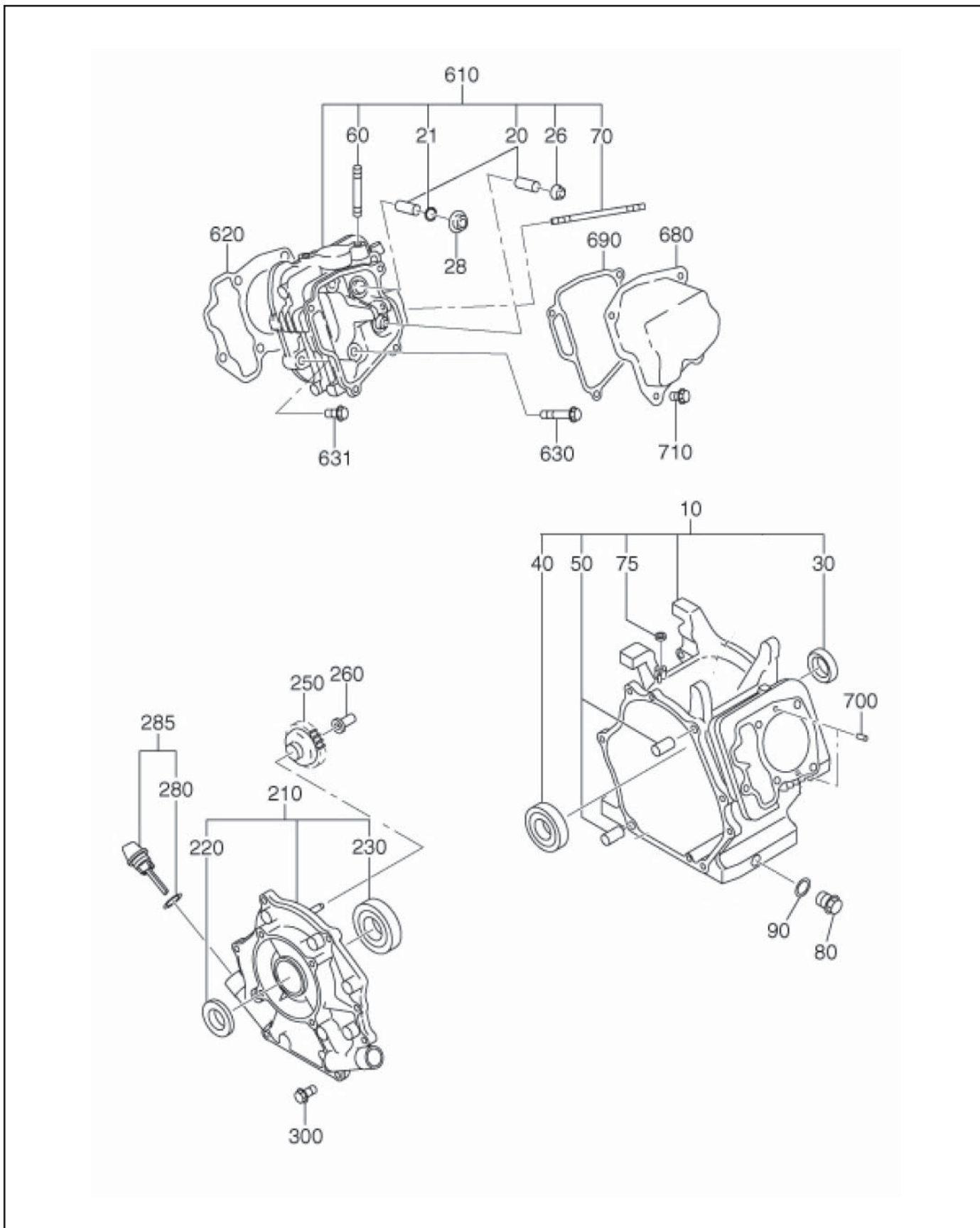



FIG. 2 CRANKSHAFT GROUP

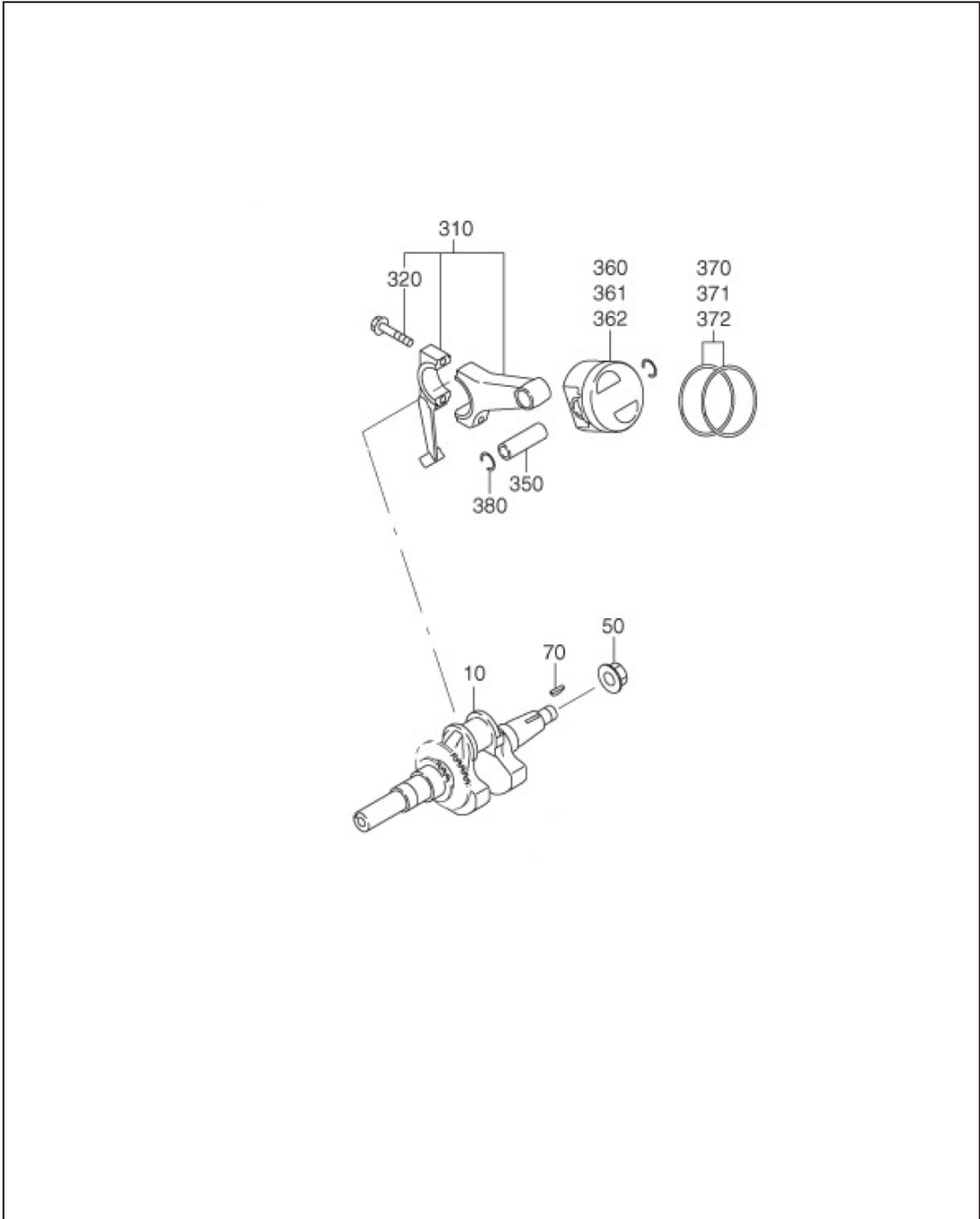
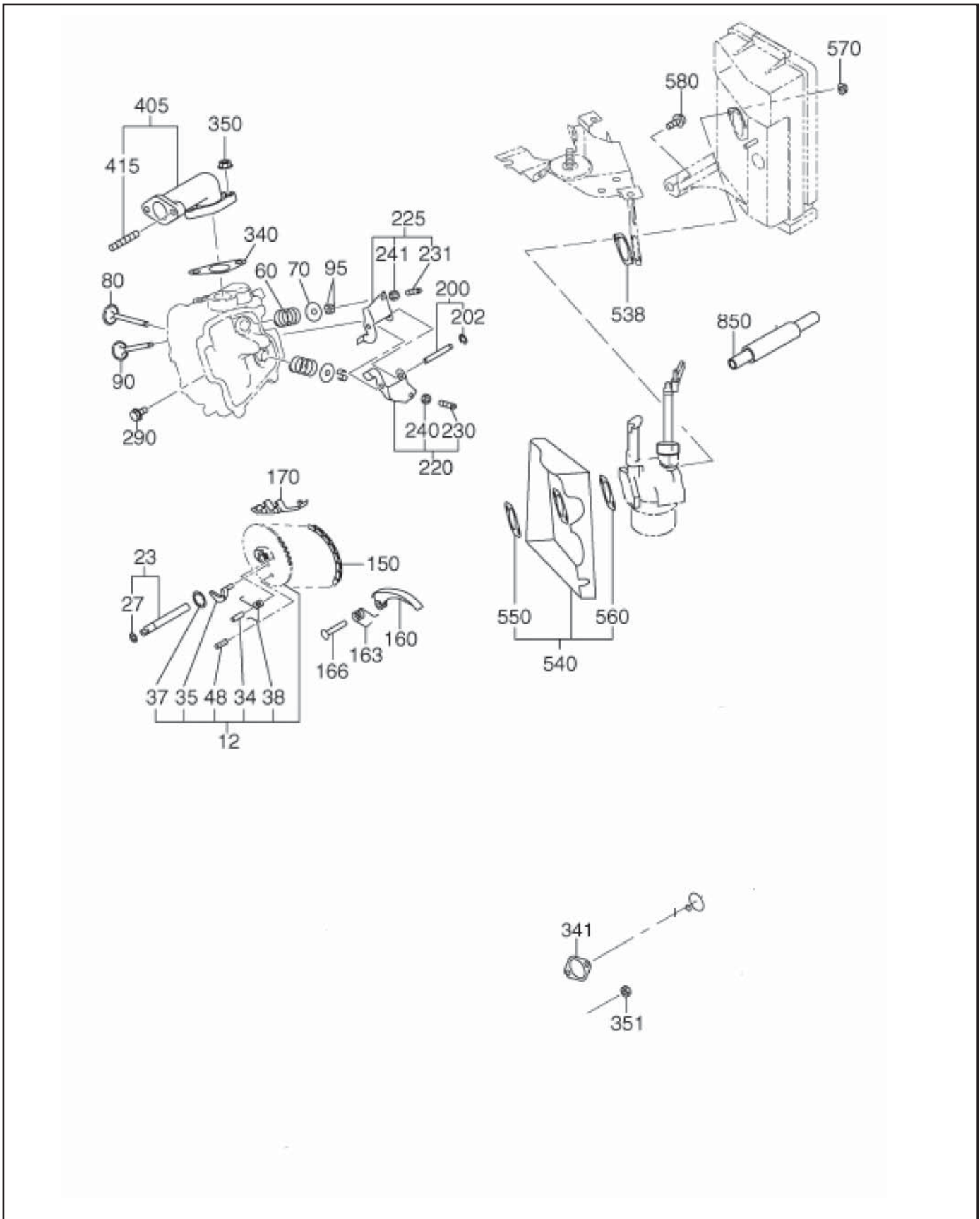



FIG. 3 INTAKE and EXHAUST GROUP





**FIG. 3 INTAKE and EXHAUST GROUP**

Ref.	Part Number	Description	Qty	Remarks	To-From	Fig.
12	20B-31601-10	CAMSHAFT AY	1		8522-	300
	20B-31601-00	CAMSHAFT AY	1		-8521	300
23	20B-35101-21	PIN(CAM SHAFT)CP	1		8583-	300
	20B-35101-11	PIN(CAM SHAFT)CP	1		-8582	300
27	024-00700-21	O-RING	1		8583-	300
	024-00700-20	O-RING	1		-8582	300
34	005-19041-00	SPRING PIN	2	4.4DX10LX0.8T	-8521	300
	005-19041-00	SPRING PIN	1	4.4DX10LX0.8T	8522-	300
35	277-36401-03	RELEASE LEVER	1		-	300
37	20B-36501-03	CLIP	1		-	300
38	277-38702-03	RETURN SPRING	1	5.1DX0.6DX4.4L N=7	-	300
48	031-80500-20	ROLL PIN	1		-	300
60	246-33611-03	VALVE SPRING	2	22.2DX2.9DX37L N=6.5	-	300
70	246-33711-13	SPRING RETAINER	2	7.6DX26DX8T	-	300
80	20B-33401-H3	INTAKE VALVE	1		-	300
90	20B-33501-H3	EXHAUST VALVE	1		-	300
95	246-35501-03	COLLET-VALVE	4		-	300
150	20B-35601-H1	TIMING CHAIN CP	1		-	300
160	277-36911-03	TENTIONER	1		-	300
163	277-37101-03	SPRING(TENTIONER)	1	10DX1.8DX14L N=4.5	-	300
166	277-36902-03	PIN(TENTIONER)	1	6DX13DX34L	-	300
170	277-36913-13	CHAIN GUIDE	1		-	300
200	20B-35001-01	PIN(ROCKER)CP	1		-	300
202	003-13060-00	CLIP	1	6DX12DX0.8T	-	300
220	20B-36101-00	ROCKER ARM(IN) AY	1		-	300
225	20B-36102-10	ROCKER ARM(EX) AY	1		-	300
230	014-90500-20	ADJUST SCREW	1	M5X0.5X23L	-	300
231	014-90500-20	ADJUST SCREW	1	M5X0.5X23L	-	300
240	017-00500-30	NUT	1	M5X0.5X4.1H	-	300
241	017-00500-30	NUT	1	M5X0.5X4.1H	-	300
290	011-00600-10	FLANGE BOLT	1	M6X1.0X14DX8L	-	300
340	20B-35201-03	GASKET(MUFFLER)	1		-	300
341	277-35201-01	GASKET CP(EXHAUST)	1	T=1.6 28D 8.5DX52P	-	300
350	002-38080-00	FLANGE NUT	2	M8X1.25X17DX7.5H	-	300
351	002-38080-00	FLANGE NUT	2	M8X1.25X17DX7.5H	-	300
405	20B-34001-01	EXHAUST PIPE CP	1		-	300
415	010-50802-90	STUD	2	M8X1.25X30L	-	300
538	20B-35903-13	GASKET 3	1		-	300
540	20B-32901-J1	INSULATOR CP	1		-	300
550	20B-35902-H3	GASKET 2	1		-	300
560	20B-35901-H3	GASKET 1	1		-	300
570	002-38060-00	FLANGE NUT	2	M6X1.0X13DX6H	-	300
580	001-04061-60	FLANGE BOLT	1	M6X1.0X13DX16L	-	300
850	X85-11001-70	RUBBER PIPE	1		-	300

**FIG. 3 INTAKE and EXHAUST GROUP**

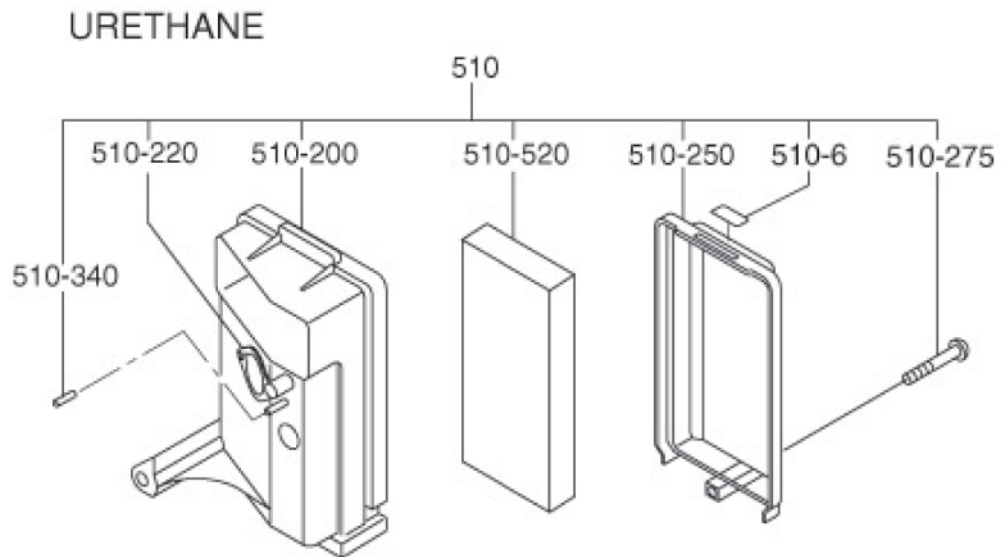
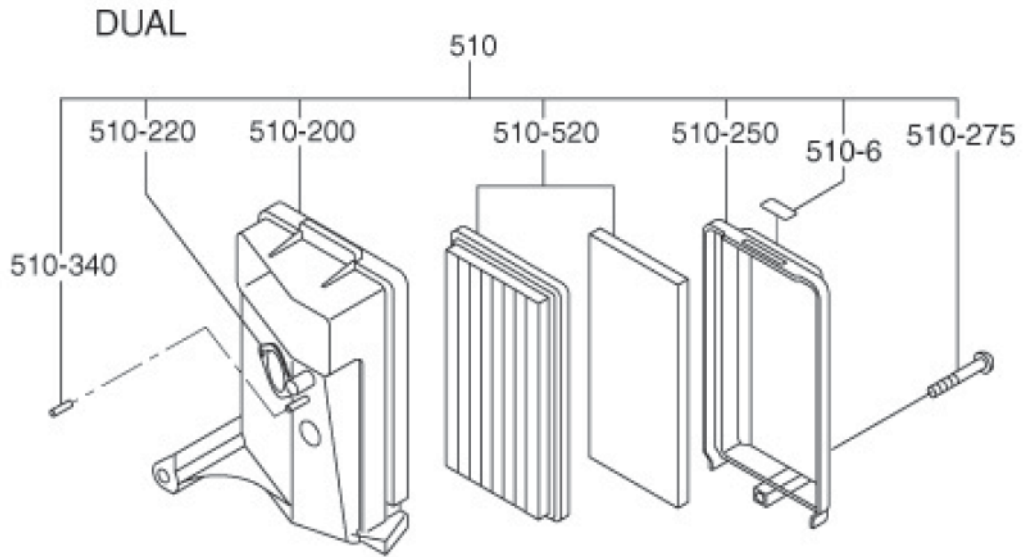
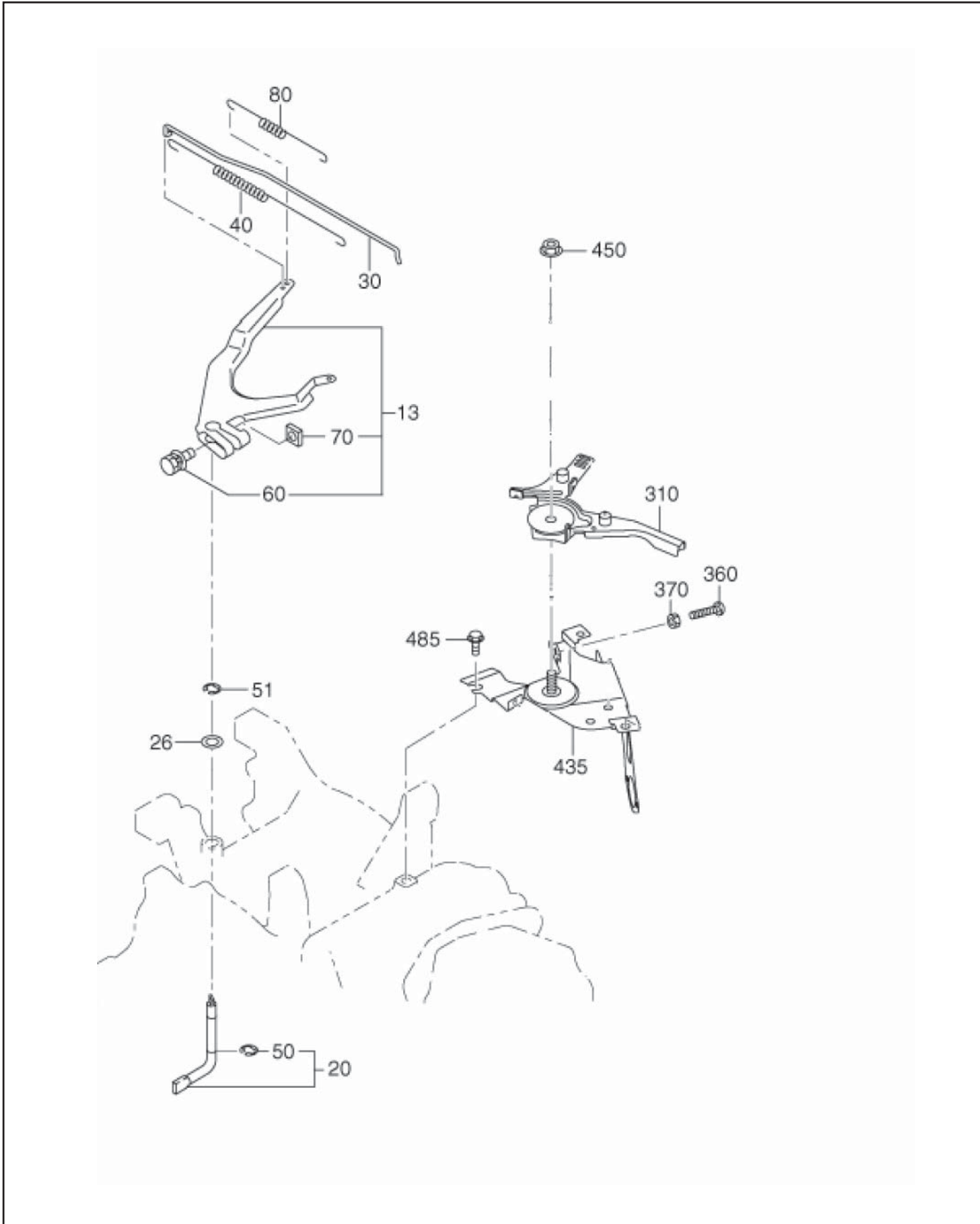

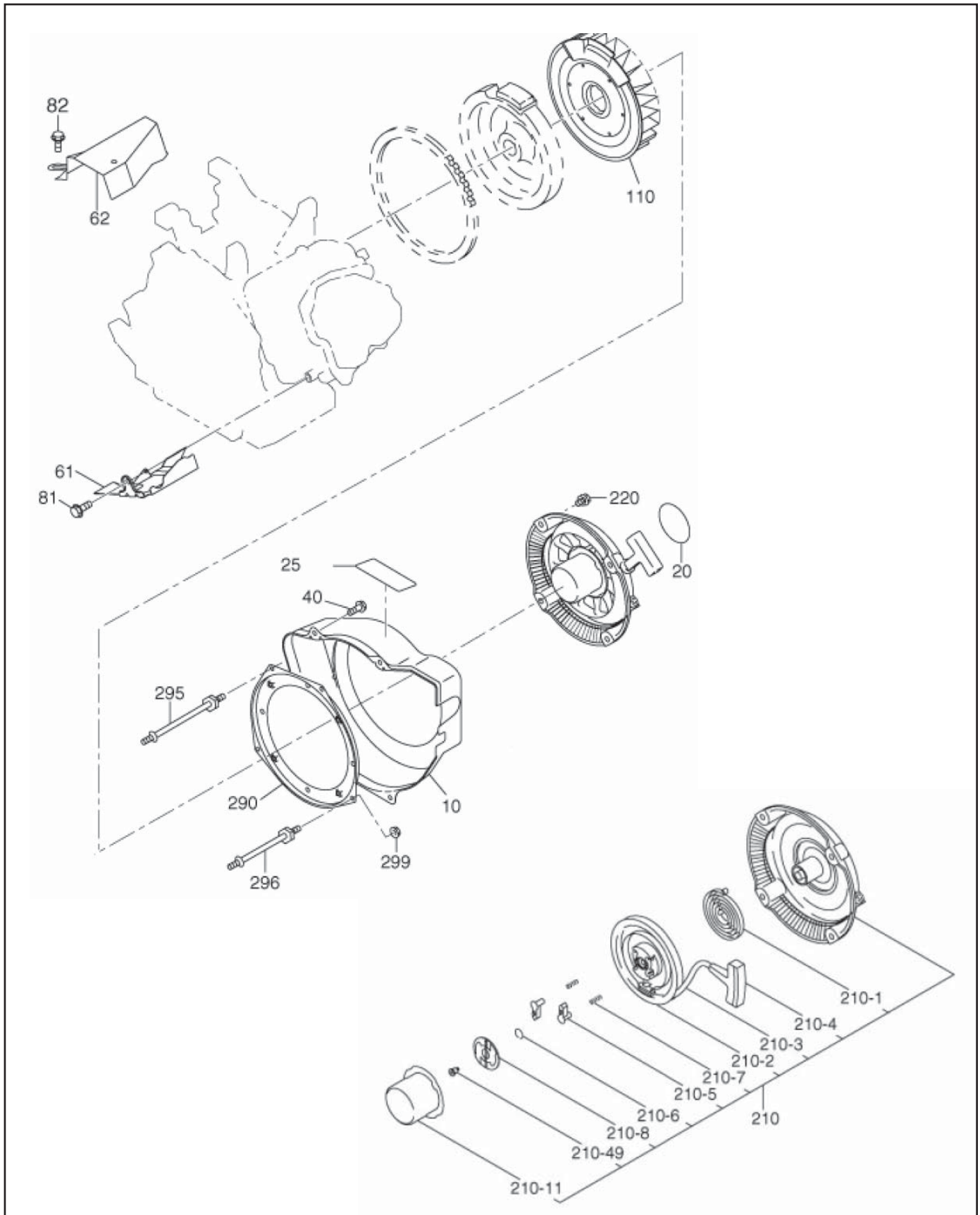

FIG. 4 GOVERNOR GROUP



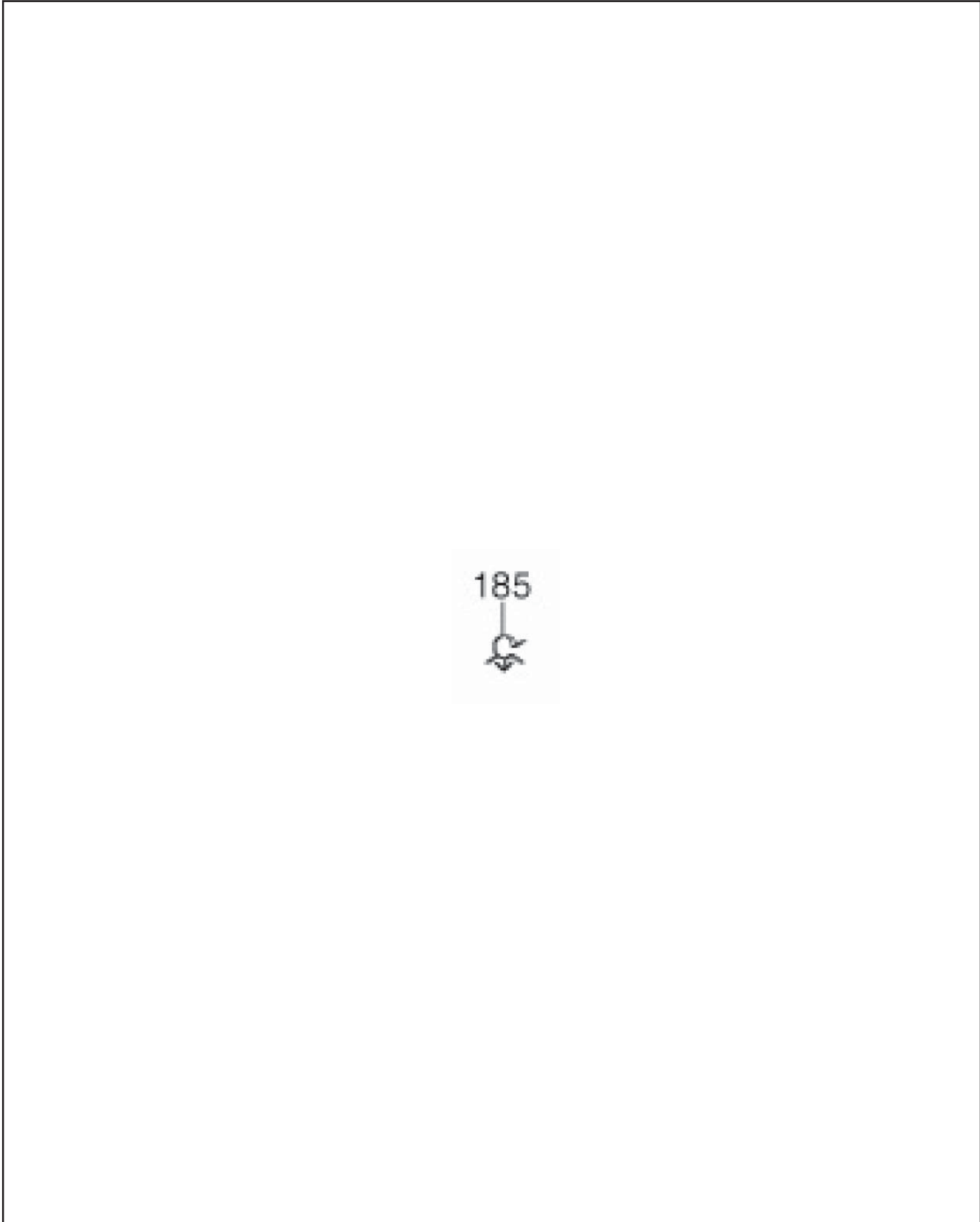

**FIG. 5 COOLING and STARTING GROUP**





**FIG. 6 FUEL LUBRICANT GROUP**



185  
↓  
⊕





**FIG. 6 FUEL LUBRICANT GROUP**

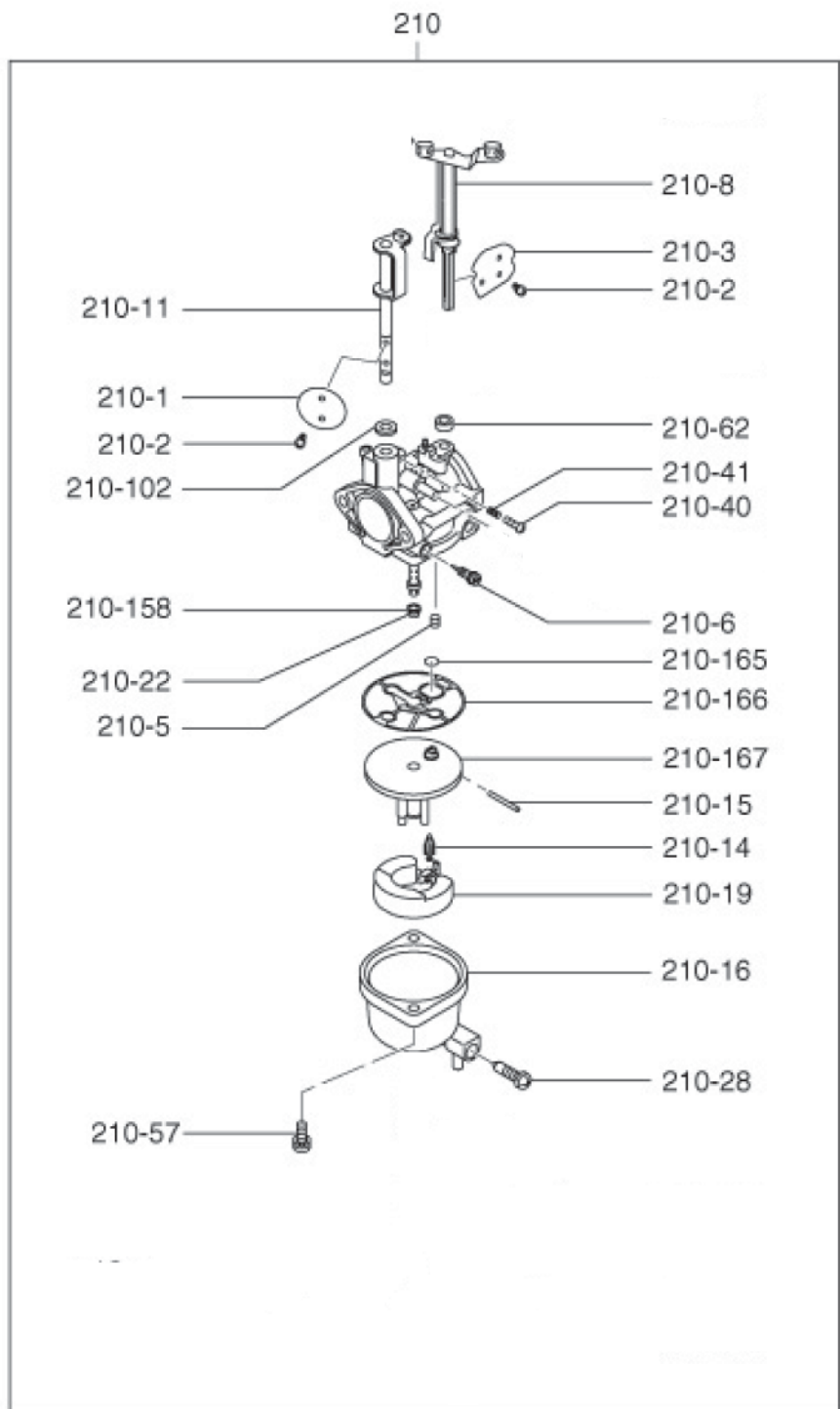



FIG. 7 ELECTRIC GROUP

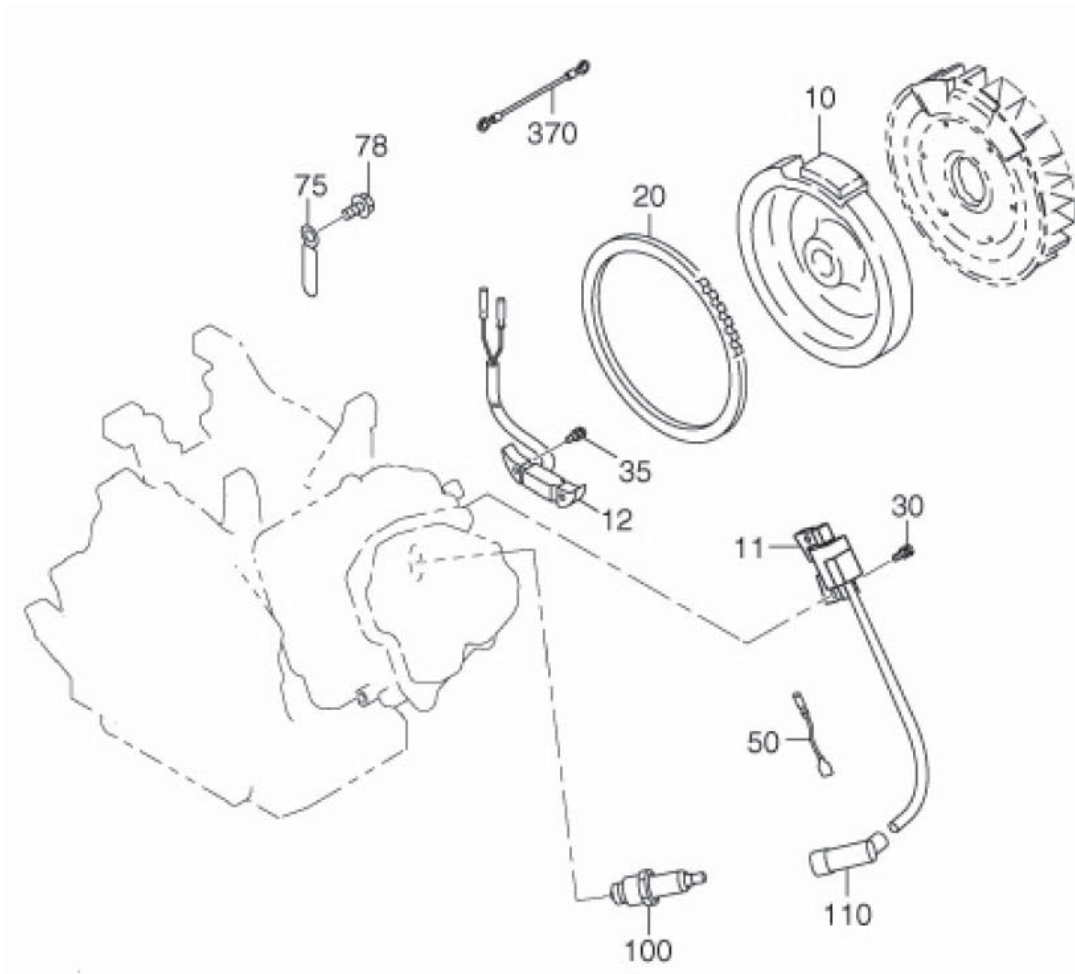
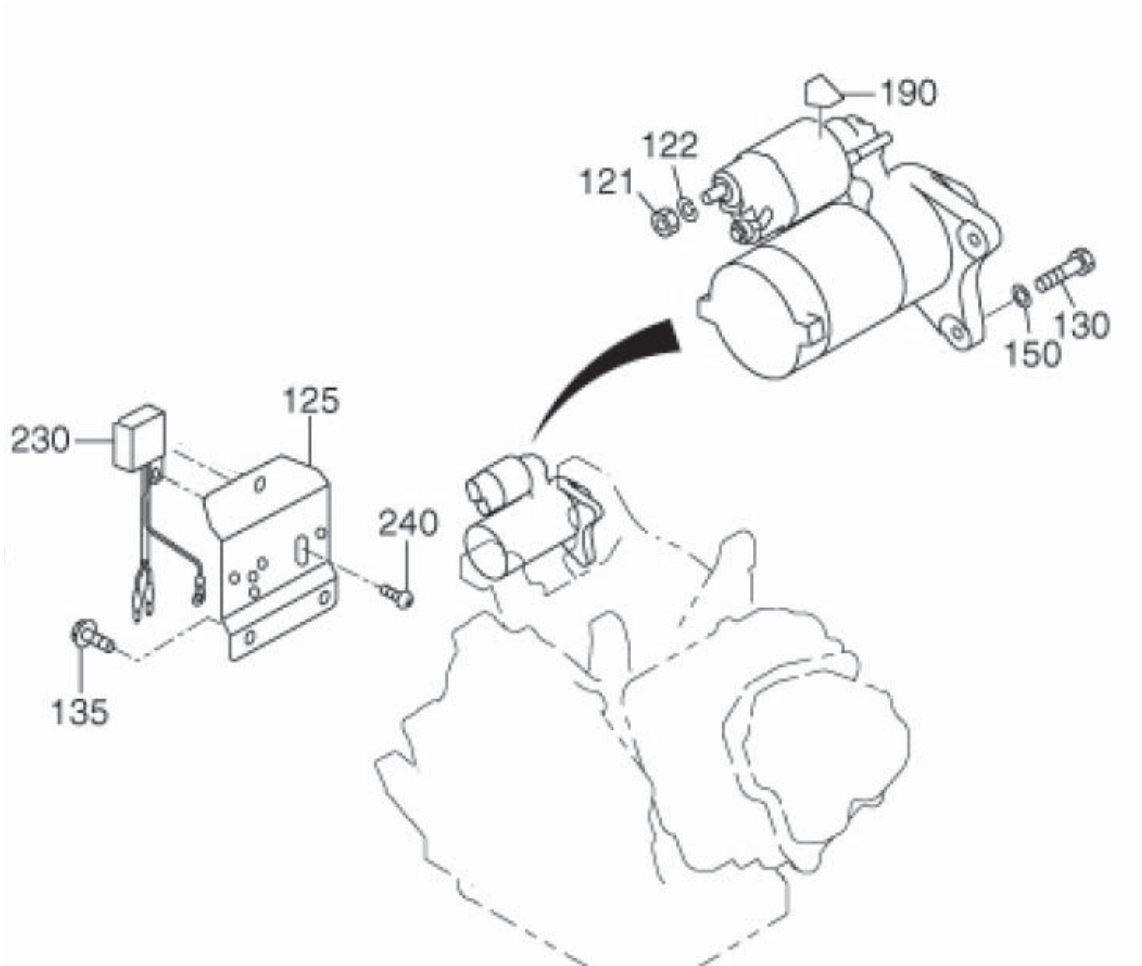



FIG. 7 ELECTRIC GROUP





**FIG. 7 ELECTRIC GROUP**

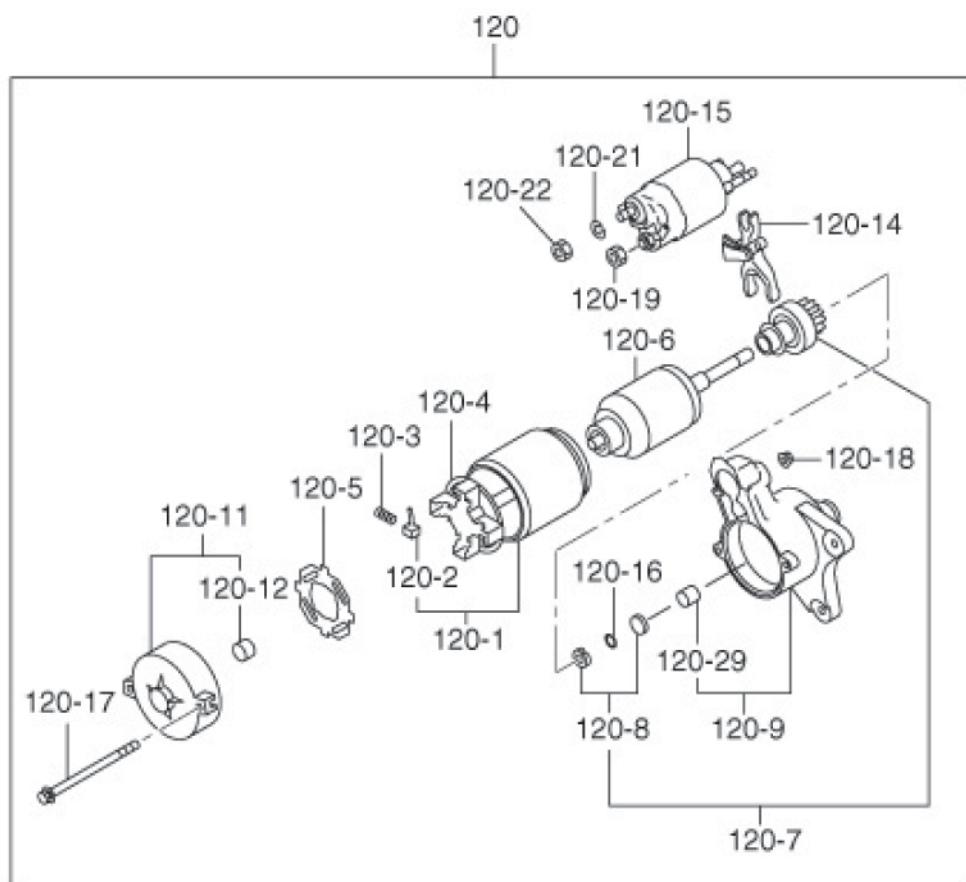





FIG. 7 ELECTRIC GROUP

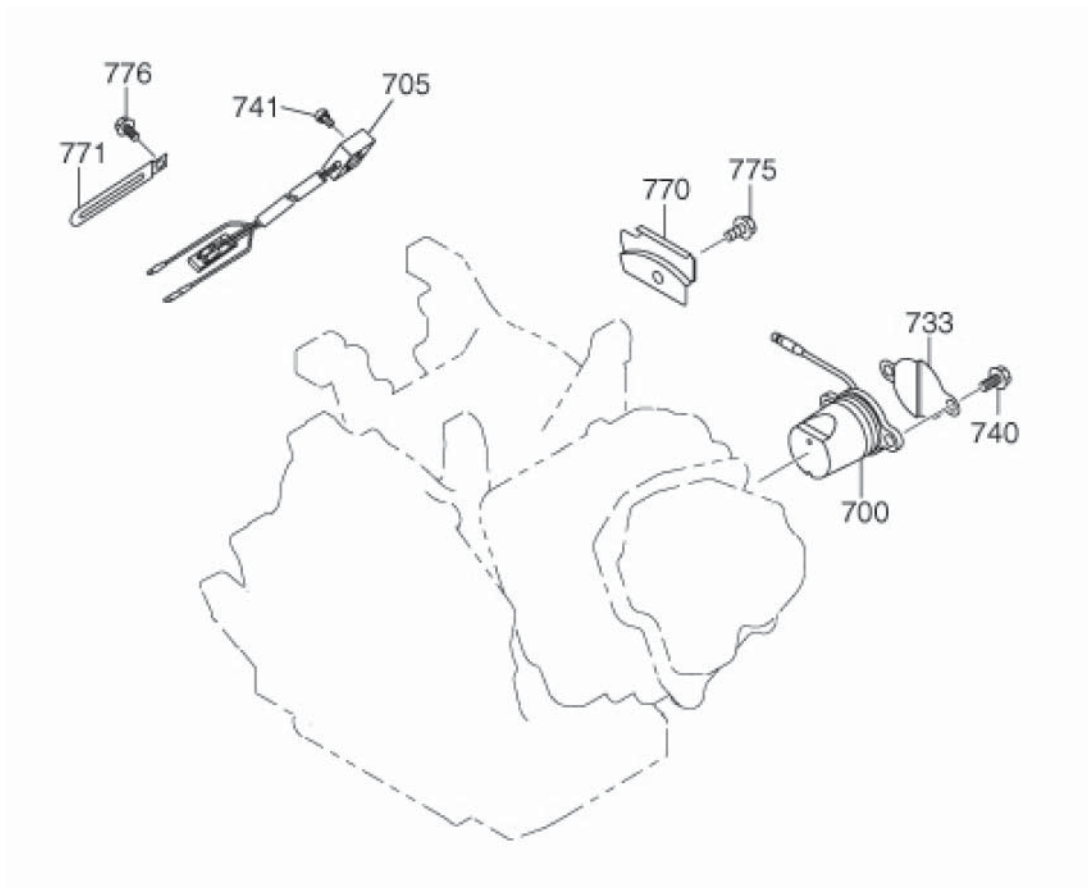



FIG. 22 GROUP

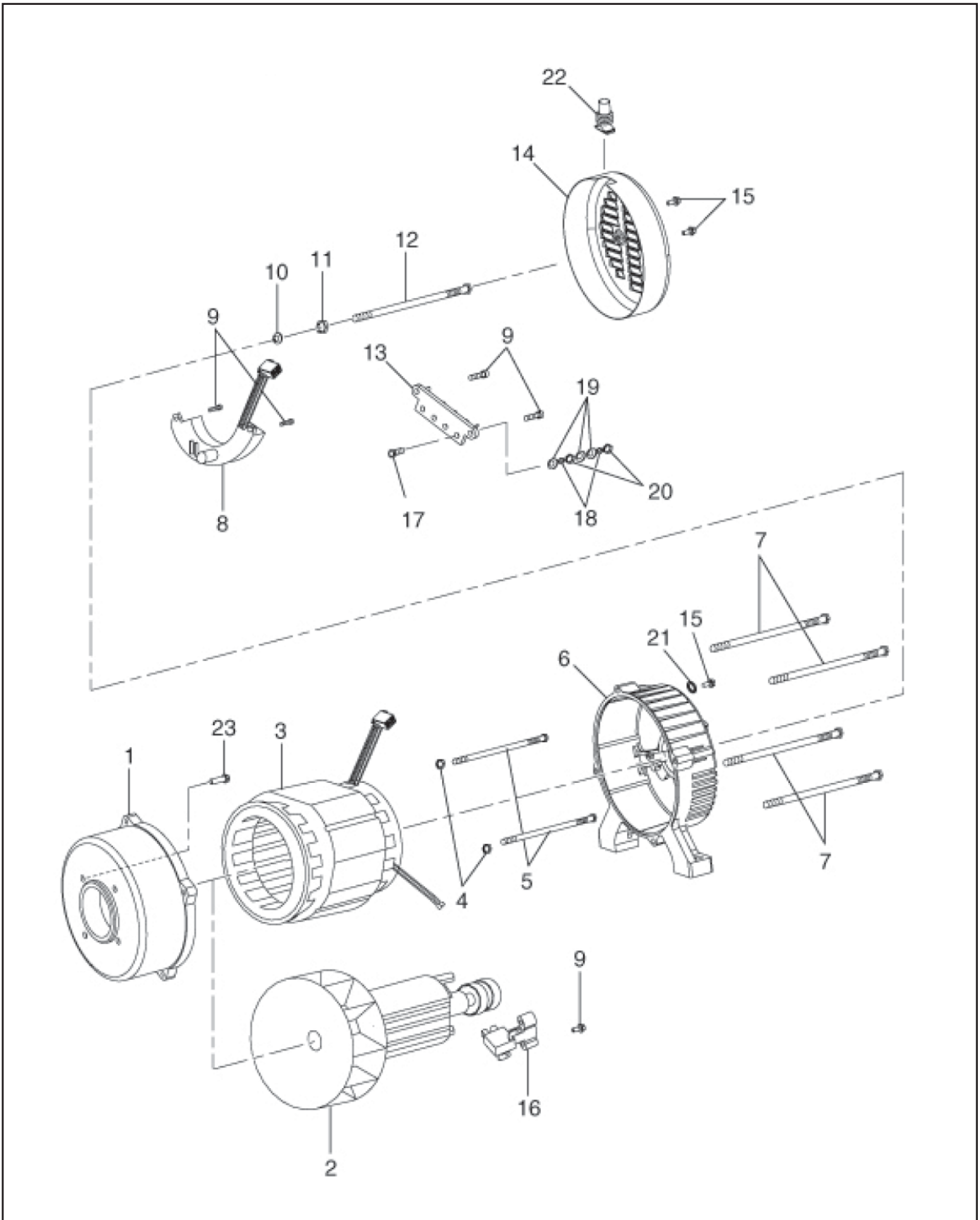
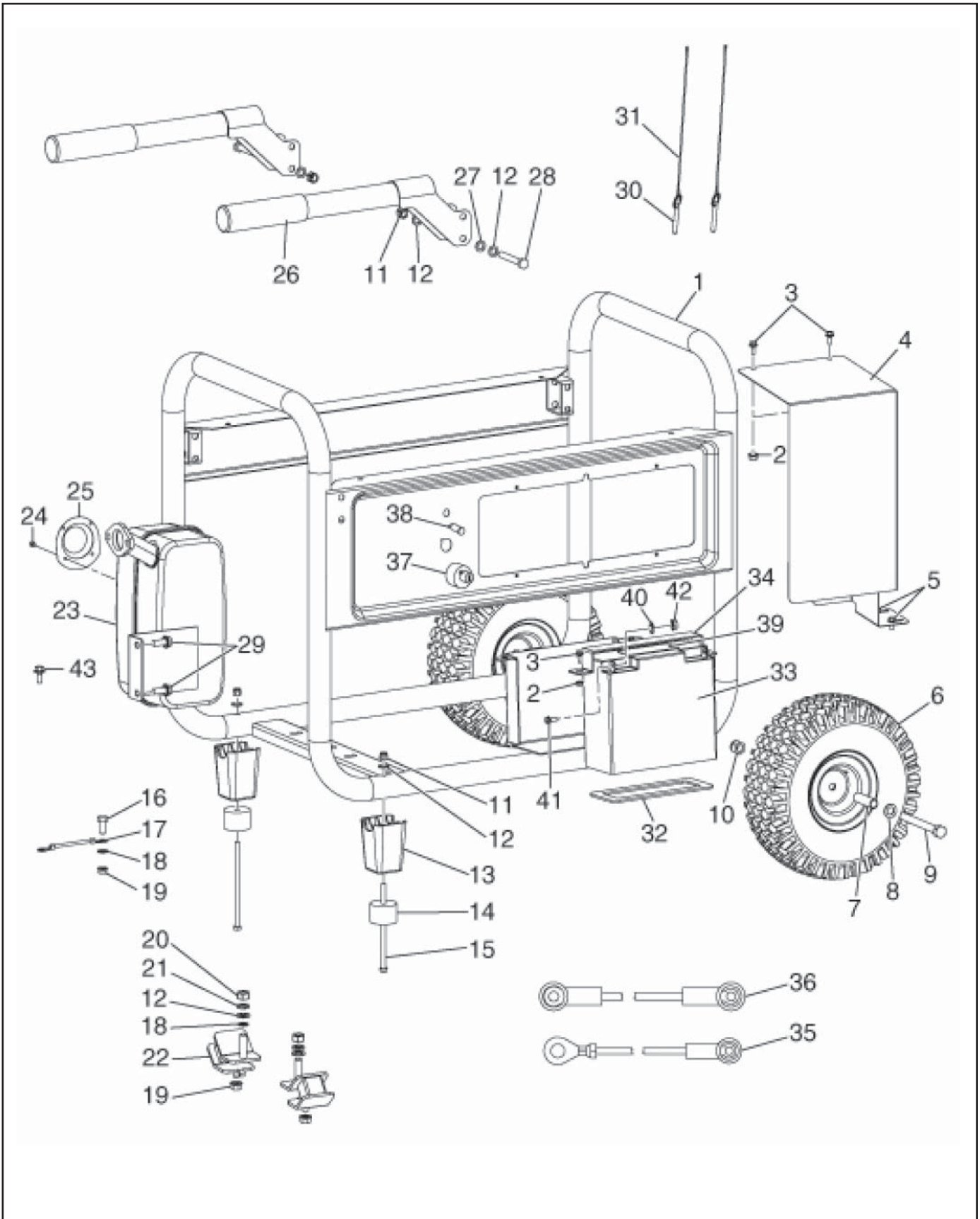



FIG. 23 GROUP



## FIG. 23 GROUP

Ref.	Part Number	Description	Qty	Remarks	To-From	Fig.
1	RGR30030001	CARRIER ASSY	1		-	2300
2	RGR325491002	NUT HEX FLANGE	4		-	2300
3	RGRGB166741BF5	BOLT HEX FLANGE	4		-	2300
4	RGR30020014	HEATSHIELD	1		-	2300
5	RGRGB158564SF4	TAPPING SCREW	2		-	2300
6	RGR310223001	WHEEL	2		-	2300
7	RGR638498001	SPACER	2		-	2300
8	RGRGBT971W10	WASHER FLAT	2		-	2300
9	RGR661558002	BOLT HH	2		-	2300
10	RGR678659001	NUT LOCK	2		-	2300
11	RGR678259003	NUT LOCK	4		-	2300
12	RGRGBT971W8	WASHER FLAT	10		-	2300
13	RGR80010012	PLASTIC FOOT	2		-	2300
14	RGR570355001	RUBBER FOOT	2		-	2300
15	RGR0501620115	BOLT HEX	2		-	2300
16	RGR661502005	BOLT HEX	1		-	2300
17	RGR290404001	ASSY WIRE GROUND	1		-	2300
18	RGRGB8622WS8	WASHER STAR	2		-	2300
19	RGR678145002	BOLT HEX	5		-	2300
20	RGR30020015	NUT HEX	4		-	2300
21	RGRGB93WL8	WASHER LOCK	4		-	2300
22	RGR30020007	ISOLATOR GENERATOR	4		-	2300
23	RGR30030011	MUFFLER ASSY	1		-	2300
24	RGR661306001	TAPPING SCREW	4		-	2300
25	RGR30010011	SPARK ARRESTOR	1		-	2300
26	RGR310224002	HANDLE ASSY	2		-	2300
27	RGR80010014	WASHER NYLON	2		-	2300
28	RGR660591004	BOLT HEX	2		-	2300
29	RGR660599002	BOLT HEX FLANGE	2		-	2300
30	RGR310712001	RELEASE PIN	2		-	2300
31	RGR310715001	LANYARD	2		-	2300
32	RGR7001002	GASKET	1		-	2300
33	RGR75040001	BATTERY	1		-	2300
34	RGR678714006	BRACKET	1		-	2300
35	RGR290419001	BATTERY CABLE	1		-	2300
36	RGR290418001	BATTERY CABLE	1		-	2300
37	RGR30030012	SWITCH	1		-	2300
-1	RGR1036350001	KEY	1		-	2300
38	227-77002-00	LED LAMP AY	1		-	2300
39	RGR570630002	GASKET	1		-	2300
40	RGRGBT95W5	WASHER FLAT	2		-	2300
41	RGRGBT292B5	BOLT	2		-	2300
42	RGRGBT61771	NUT HEX FLANGE	2		-	2300
43	RGRGB5789BF616	BOLT HEX FLANGE	1		-	2300

FIG. 24 GROUP

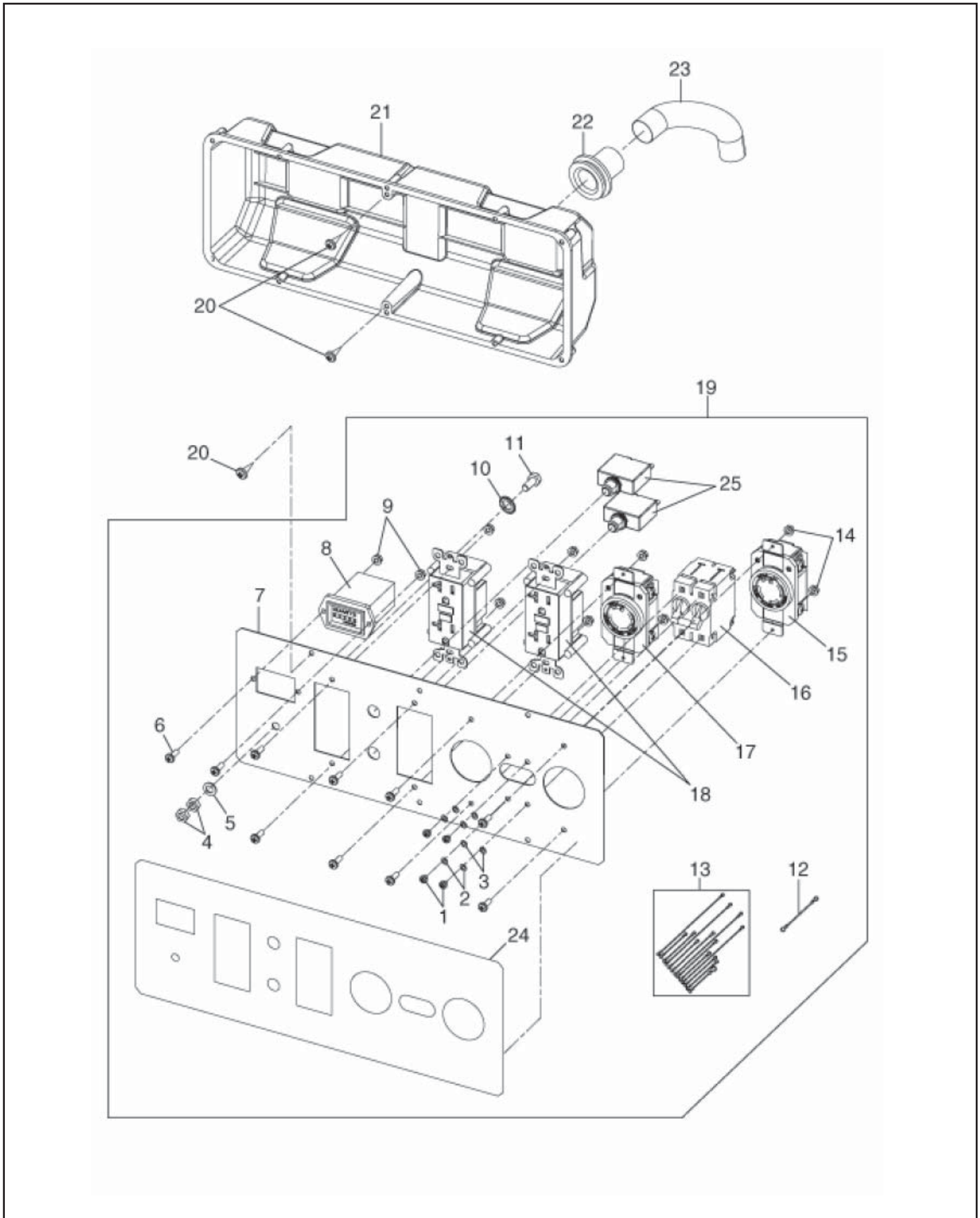





FIG. 26 GROUP

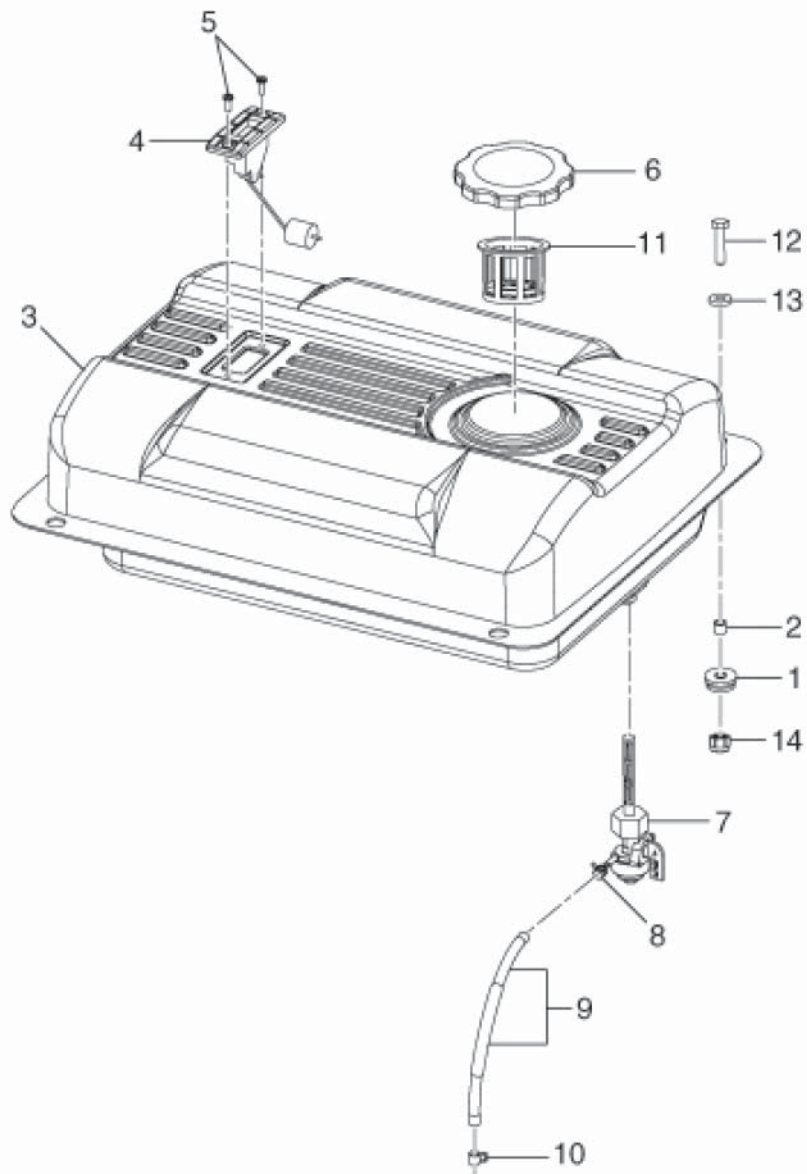
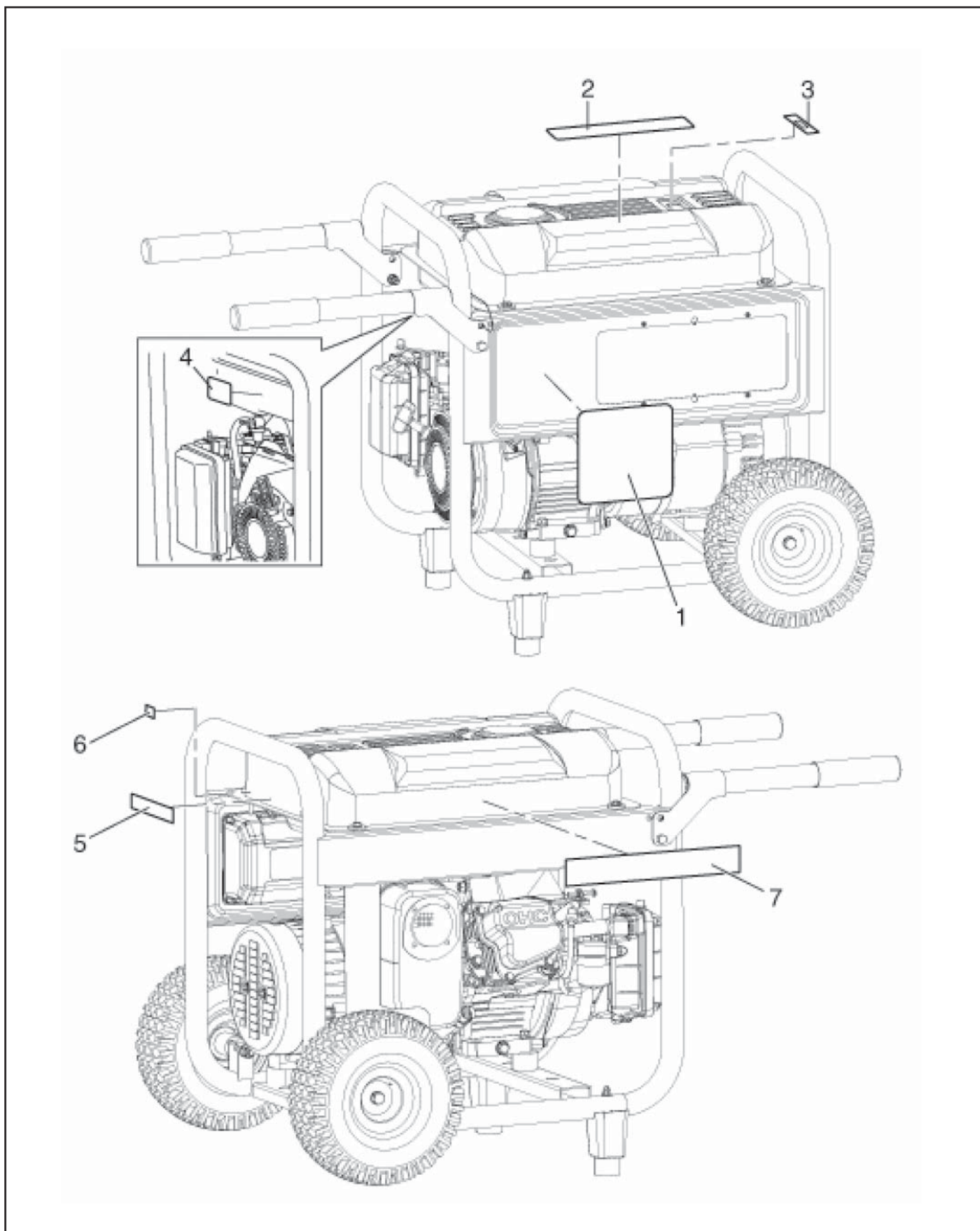



FIG. 29 GROUP





PRINTED IN THE USA

## Robin America, Inc

905 Telsler Road • Lake Zurich, IL 60047  
Phone: 847-540-7300 • Fax: 847-438-5012  
e-mail: [sales@robinamerica.com](mailto:sales@robinamerica.com) • [www.subarupower.com](http://www.subarupower.com)