

**STERLCOOL PORTABLE CHILLER**  
Service and Instruction Manual  
Models: CFP05-W through CFP30-W  
and CFP05-A through CFP25-A

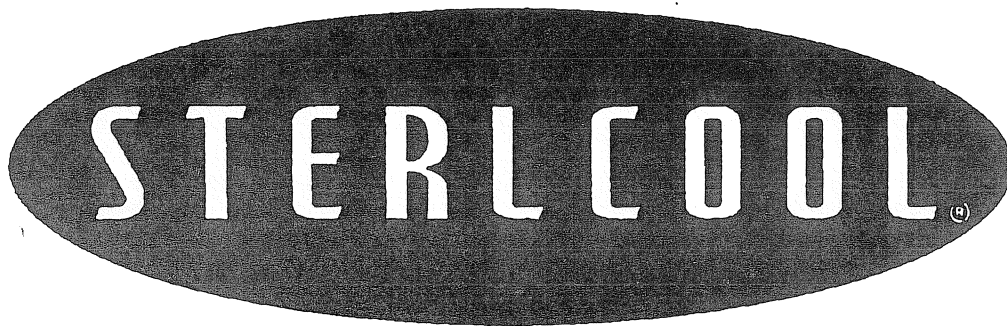

**Process  
Cooling / Chilling  
Systems**

**STERLING, INC.**  
5200 West Clinton Avenue, P.O. Box 23435, Milwaukee, Wisconsin 53223-0435  
*Manufacturers of Temperature Control Equipment Since 1916*

STERLING, INC. warrants all portable chillers to be free from defects in workmanship and material when used under the conditions recommended by STERLING, INC.

The Company's obligation under this warranty is limited to make good, at its factory, any parts which shall, within one (1) year after delivery of equipment of its manufacture to the original purchaser, be returned to STERLING, INC., with transportation prepaid, and which its examination shall disclose to its satisfaction to have been defective. The Company neither assumes nor authorizes any other person or persons to assume for it any liability in connection with the sale of its equipment, except under the conditions of this warranty.

This warranty does not cover any labor charges for replacement of parts, adjustments, repair, nor any other work done. This warranty shall not apply to any apparatus which, in its opinion, has been subjected to misuse, negligence, temperatures, or pressures in excess of the limits recommended by the Company, or which shall have been repaired or altered outside the Company's factory.

Replacement of defective material will be F.O.B. our factory.

Replacement of component parts not of its manufacture will be limited to the warranty of the manufacturer of such parts.

# Table of Contents



<b>SAFETY CONSIDERATIONS</b>	<b>2</b>
<b>GENERAL INFORMATION</b>	<b>3</b>
INTRODUCTION . . . . .	3
NECESSARY DOCUMENTS . . . . .	3
MODELS COVERED . . . . .	3
AVAILABLE OPTIONS . . . . .	4
Operating Voltages . . . . .	4
Cooling Ranges . . . . .	4
Intake Air Filters . . . . .	4
Special Pumps . . . . .	4
Reservoirs . . . . .	4
Static Fans . . . . .	4
Automatic Make Up Systems . . . . .	4
Low Ambient Fan Cycling Pressure Switch . . . . .	5
UNCRATING . . . . .	5
WATER-COOLED PORTABLE CHILLER SPECIFICATIONS . . . . .	6
AIR-COOLED PORTABLE CHILLER SPECIFICATIONS . . . . .	7
<b>INSTALLATION</b>	<b>8</b>
ELECTRICAL CONNECTIONS . . . . .	8
PROCESS WATER CONNECTIONS - ALL MODELS . . . . .	8
To Process . . . . .	8
From Process . . . . .	8
Process Water Connection Sizing Considerations . . . . .	8
Process Water By-Pass Valve . . . . .	8
Water Treatment . . . . .	10
WATER-COOLED CONDENSER WATER SUPPLY . . . . .	10
Condenser Water In . . . . .	10
Condenser Water Out . . . . .	10

AIR-COOLED CONDENSER AIR SUPPLY .....	10
Condensing Air Temperature .....	12
MOTOR DIRECTION CHECK .....	12
Compressor .....	12
Water Pump .....	12
Condenser Fan .....	12
WATER RESERVOIR .....	12
AUTOMATIC WATER MAKE UP OPTION .....	14
AVOIDING FREEZE-UP WITH AUTO MAKE-UP .....	15
Chemical Feeder .....	15
Make Up Reservoir .....	15
<b>SEQUENCE OF OPERATION</b> .....	<b>16</b>
CHILLED WATER CIRCUIT .....	16
REFRIGERATION CIRCUIT .....	16
<b>ELECTRO-MECHANICAL COMPONENTS</b> .....	<b>24</b>
FREEZESTAT CONTROL .....	24
CRANKCASE HEATER .....	24
HIGH PRESSURE CUT OUT .....	24
LOW PRESSURE CUT OUT .....	24
OIL PRESSURE SWITCH - 15, 20, 25 & 30 HP Compressors .....	25
FAN CYCLING SWITCH - Air-cooled Models Only .....	25
CFP05-A and CFP7.5-A .....	25
CFP10-A Through CFP25-A .....	25
CFP10-A Through CFP25-A with Optional Fan Cycling Switch .....	25
FLOAT SWITCH .....	25
REMOTE START/STOP INTERLOCK .....	26
<b>START-UP CHECK LISTS</b> .....	<b>27</b>
INTRODUCTION .....	27



WATER-COOLED CHILLER START-UP CHECK LIST . . . . .	27
WATER-COOLED CHILLER START-UP . . . . .	27
AIR-COOLED CHILLER START-UP CHECK LIST . . . . .	28
AIR-COOLED CHILLER START-UP . . . . .	28

**CONTROL OPERATION** **29**

---

THE MICROPROCESSOR CONTROL . . . . .	29
CONTROL OPERATION RANGE . . . . .	30
CONTROL PANEL INDICATOR LIGHTS . . . . .	30
Green PV LED . . . . .	30
Orange SV LED . . . . .	30
OUT (1) LED . . . . .	30
OUT (2) LED . . . . .	30
AT LED . . . . .	30
ALM 1 LED . . . . .	30
ALM 2 LED . . . . .	30
CONTROL PUSH-BUTTONS . . . . .	31
Set Button . . . . .	31
Down Arrow Button . . . . .	31
Up Arrow Button . . . . .	31
Left Arrow Button . . . . .	31
MICROPROCESSOR CONTROL OPERATION . . . . .	31

**GRAPHIC PANEL** **32**

---

INTRODUCTION . . . . .	32
HIGH REFRIGERANT PRESSURE LIGHT . . . . .	32
LOW REFRIGERANT PRESSURE LIGHT . . . . .	32
LOW OIL PRESSURE LIGHT . . . . .	32
LOW WATER LEVEL LIGHT . . . . .	32
LOW WATER TEMPERATURE LIGHT . . . . .	33
SYSTEM POWER LIGHT . . . . .	33

<b>ROUTINE MAINTENANCE</b>	<b>34</b>
<hr/>	
LUBRICATION .....	34
CLEANING AIR-COOLED CHILLER FILTERS .....	34
CONDENSER MAINTENANCE .....	34
Air-Cooled: .....	34
Water-Cooled: .....	34
<b>TROUBLESHOOTING CHECK LIST</b>	<b>35</b>
<hr/>	

Note: Performance figures stated in this manual are based on a Standard Atmosphere of 59°F at 29.92" Hg (1013.2 millibars), at sea level, using 60 hz power. Ambient air temperature is an important consideration in choosing a chiller. Sterling, Inc. can advise you on proper selection and sizing of systems for your operating environment.

Sterling, Inc. is committed to a continuing program of product improvement. Specifications, appearance, and dimensions described in this manual are subject to change without notice.

# 1. SAFETY CONSIDERATIONS

---

STERLCOOL Portable Chillers are designed to provide safe and reliable operation when installed and operated within design specifications, following national and local safety codes.

To avoid possible personnel injury or equipment damage when installing, operating or maintaining this equipment, use good judgment and follow these safe practices:

- Follow all SAFETY CODES.
- Wear SAFETY GLASSES and WORK GLOVES.
- Use care when LOADING, UNLOADING, RIGGING or MOVING this equipment.
- Operate this equipment within design specifications.
- OPEN, TAG AND LOCK ALL DISCONNECTS before working on equipment. It is a good idea to remove the fuses and carry them with you.
- Make sure the chiller is properly GROUNDED before switching power on.
- When welding or brazing in or around this equipment be sure VENTILATION is ADEQUATE. PROTECT adjacent materials from flame or sparks by shielding with sheet metal. An approved FIRE EXTINGUISHER should be close at hand and ready for use if needed.
- The refrigeration system can develop refrigerant pressures in excess of 500 PSI. DO NOT CUT into the system until pressure has been relieved.
- Do not jump or bypass any electrical safety control.
- Do not restore power until all tools, test equipment etc. have been removed and the panels replaced.
- Only PROPERLY TRAINED personnel familiar with the information within this manual should work on this equipment.

## 2. GENERAL INFORMATION

---

### 2.1. INTRODUCTION

---

STERLCOOL's Portable Water Chillers are reliable, accurate and easy to use process cooling units. They are available in both air- and water-cooled designs in a range of sizes from 5 to 30 horsepower. All are self contained, fully assembled and shipped ready to use.

A properly installed, operated and maintained Portable Chiller will provide many years of reliable operation. To get the most satisfaction from your new chiller, read and follow the instructions in this manual.

### 2.2. NECESSARY DOCUMENTS

---

The following documents are necessary for the operation, installation and maintenance of STERLCOOL's Portable Chillers. Additional copies are available from Sterling, Inc. Familiarize the appropriate personnel with these documents:

- This manual.
- The electrical schematic and connection diagram mounted inside the control enclosure. Typical schematics for general reference are provided in Figures 14 and 15.
- The operation and installation manuals for installed accessories and options.
- The Customer Parts List included in the information packet.

### 2.3. MODELS COVERED

---

This manual provides operation, installation, and maintenance instructions for STERLCOOL Portable Chillers.

Model numbers can be found on the chiller's serial tag. Please know the model number, serial number and operating voltage of your chiller if you need to contact Sterling, Inc.

Portable Chiller models are designated by compressor horsepower (5, 7½, 10, 15, 20, 25, and 30) and the cooling method used. For example, a five horsepower air-cooled portable chiller is designated CFP05-A; a water-cooled five horsepower unit is a CFP05-W.

All sizes are available with either cooling method with the exception of the 30 horsepower, which is available in the water-cooled configuration only.

## **2.4. AVAILABLE OPTIONS**

---

Portable Chillers are available with options that tailor the unit to your requirements. Some are factory installed, some can be retro-fitted in the field. Consult your sales representative.

### **2.4.1 Operating Voltages**

Portable Chillers are available configured for 208/230-3-60, 380/415-3-50, 460-3-60, 515-3-50, 575-3-60 volts.

### **2.4.2 Cooling Ranges**

Portable Chillers are offered in two cooling ranges. R-22 charged chillers cool 20°F to 70°F processes. Low temperature R-502 units are used with 0°F to 30°F processes.

### **2.4.3 Intake Air Filters**

Intake air filters are highly recommended for air-cooled Portable Chillers.

### **2.4.4 Special Pumps**

Special pump options are available for greater pressure and flow rates. One and two pump configurations with 1½, 3, 5, 7½, and 10 horsepower pumps are offered.

### **2.4.5 Reservoirs**

A 40 gallon reservoir is standard. Water-cooled Portable Chillers are available without a reservoir for processes that use their own reservoir.

### **2.4.6 Static Fans**

Static fans are available for installations where the exiting air is to be exhausted through ductwork. They are available on 5 through 15 horsepower air-cooled Portable Chillers and may be field retro-fitted without sheet metal modification.

### **2.4.7 Automatic Make Up Systems**

This option includes a float valve in the reservoir and the necessary solenoid valve and pipe fittings to connect a Portable Chiller to an automatic make up system. Sterling, Inc. offers the necessary components for automatic make-up and water treatment systems. See Section 3.7 for more details.

### 2.4.8 Low Ambient Fan Cycling Pressure Switch

Applications with low ambient temperatures benefit from this option. A pressure switch in the compressor cycles the primary fan OFF and ON in low ambient temperatures to maintain efficient condensing pressures.

## 2.5. UNCRATING

- Portable Chillers are shipped mounted on a skid, enclosed in a plastic wrapper and open crated on all four sides and top.
- Pry the crating away from the skid and remove. Use a pry bar to remove the blocks securing the unit to the skid.
- Lift the unit off the skid with a fork truck. Insert forks between skid and chiller from the side until they protrude beyond the opposite side of the unit. The forks must be equidistant from the center line of the unit and the unit must be balanced on the forks.
- Lift slowly and only high enough to clear the skid. Use a pry bar if necessary to remove the skid from the unit.
- Lower slowly. The unit will land on its casters and can be rolled into position.

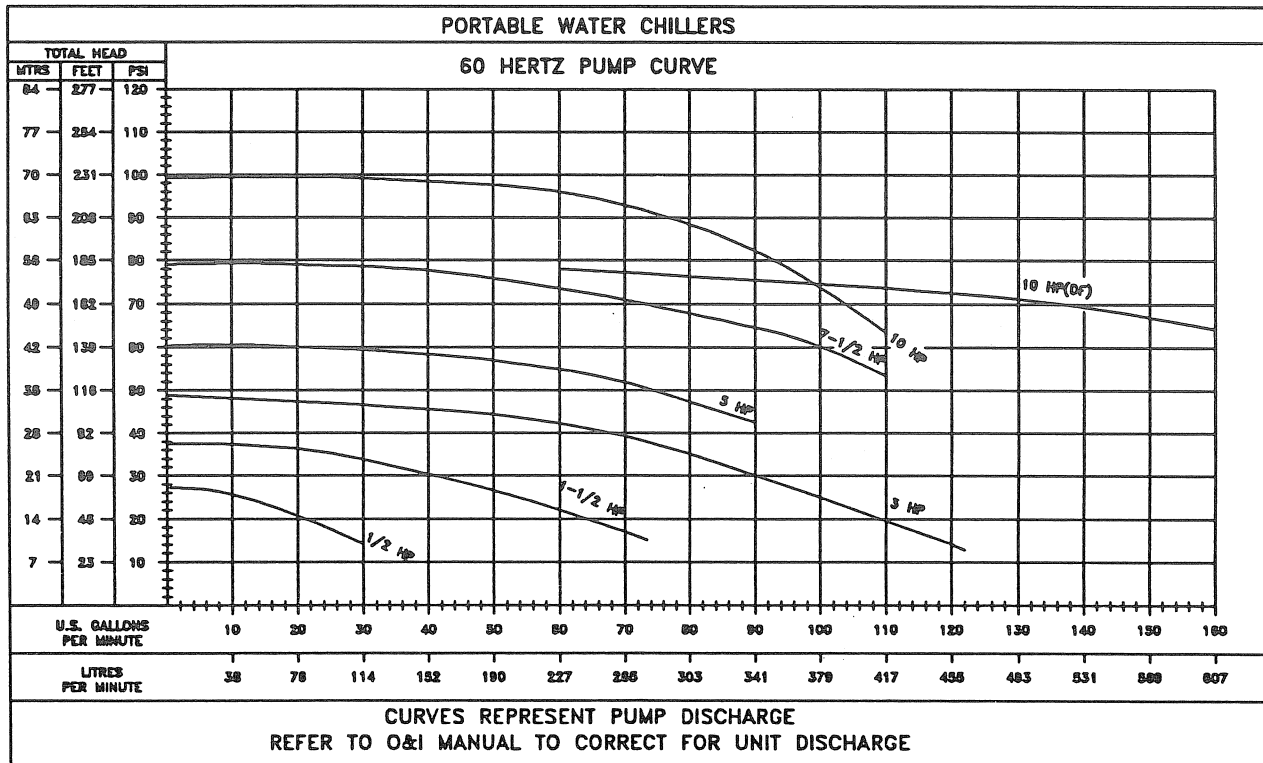
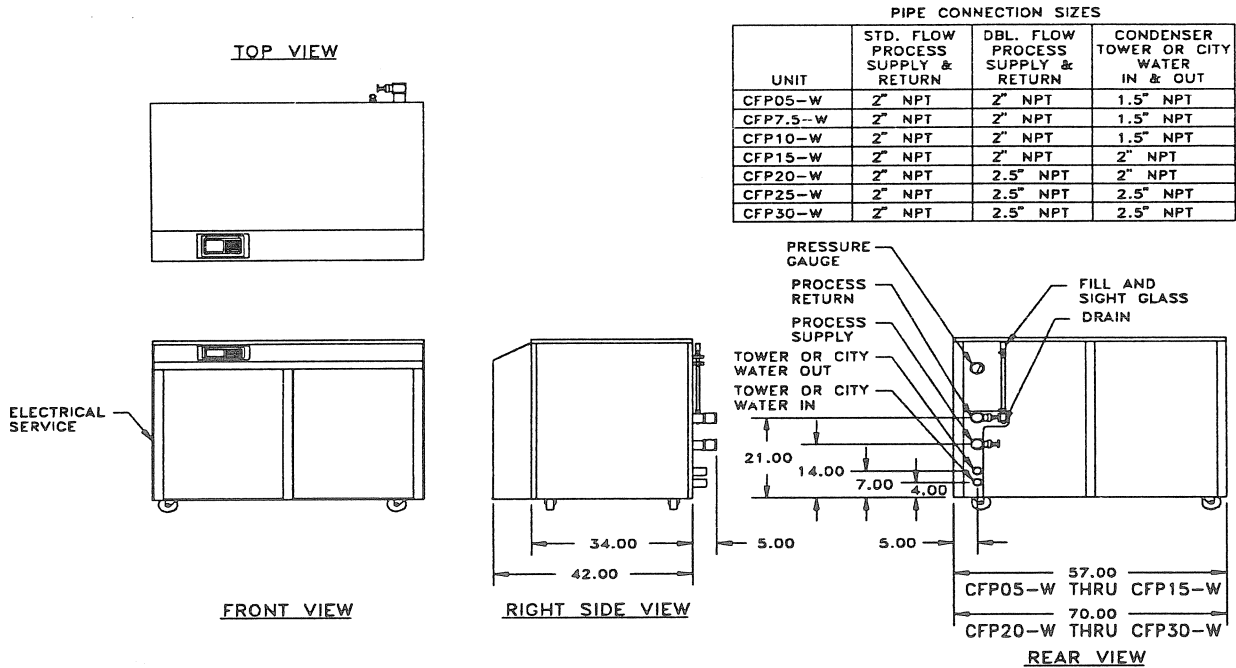

Figure 1  
60 Hertz Pump Curves

GENERAL INFORMATION

## 2.6. Water-Cooled Portable Chiller Specifications



WATER COOLED CHILLER OUTLINE DIMENSIONS  
CFP05-W THRU CFP30-W

WATER-COOLED PORTABLE CHILLER SPECIFICATIONS											
Water-Cooled Chiller Model Number	Cooling Capacity	Chilled Water	Standard Pump	Pipe Size	Total Running Amps	Nominal Condenser Water		Dimensions			Shipping Weight
	Tons	Nom. GPM	HP	Inches	460-3-60 VAC	City Water GPM	Tower Water GPM	Length Inches	Width Inches	Height Inches	Pounds
CFP05-W	6	12	1 1/2	2	13.5	6	18	65	34	45	1,400
CFP7.5-W	8	18	1 1/2	2	17.5	10	24	65	34	45	1,600
CFP10-W	10	24	1 1/2	2	23.5	12	31	65	34	45	1,625
CFP15-W	15	36	1 1/2	2	32.5	18	45	65	34	45	1,900
CFP20-W	19	45	3	2	39.5	25	60	78	34	45	2,100
CFP25-W	24	60	3	2	47.5	30	75	78	34	45	2,100
CFP30-W	27	72	5	2	65.5	36	90	78	34	45	2,200

- Based on 50°F chilled water supply temperature.
- Flow rate based on 2.4 gpm/ton at 25 psi or higher. Alternate pumps available.
- Requirement based on availability of 70°F city water or 85°F tower water at 25 psi minimum. Consult factory for other conditions.



## 2.7. Air-Cooled Portable Chiller Specifications

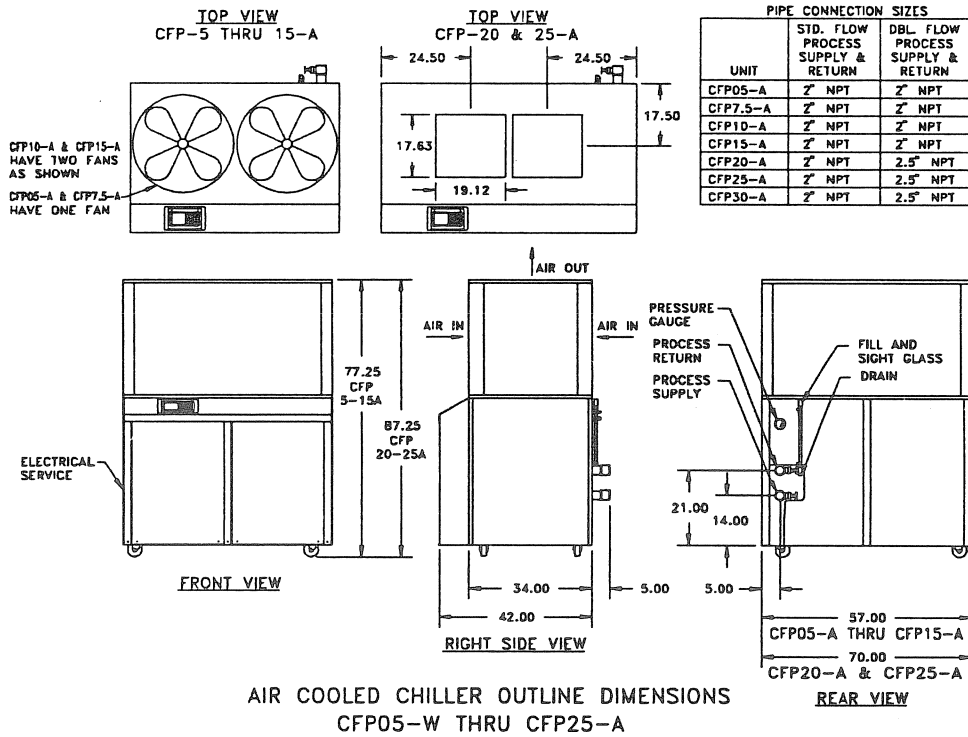

Air-Cooled Portable Chiller Specifications										
Air-Cooled Chiller Model Number	Cooling Capacity	Nominal Chilled Water	Standard Pump	Pipe Size	Total Running Amps	Condenser Air Flow	Dimensions			Shipping Weight
	Ton	GPM	HP	Inches	460-3-60 VAC	CFM	Length Inches	Width Inches	Height Inches	Pounds
CFP05-A	5	12	1½	2	15	6,000	65	34	77	1,300
CFP7.5-A	7	18	1½	2	19.5	6,000	65	34	77	2,100
CFP10-A	8½	24	1½	2	27	12,000	65	34	77	2,300
CFP15-A	13½	36	1½	2	36	12,000	65	34	77	2,400
CFP20-A	17½	45	3	2	52.5	18,000	78	34	87	2,450
CFP25-A	23	60	3	2	60.5	18,000	78	34	87	2,600

- Based on 50°F chilled water supply temperature and 95°F ambient air temperature. Consult factory for other requirements.
- Flow rate based on 2.4 gpm/ton at 25 psi or higher. Alternate pump sizes available.

## **3. INSTALLATION**

---

### **3.1. ELECTRICAL CONNECTIONS**

---

Check serial tag voltage and amperage requirements and make sure your electrical service conforms. Total running amps for Portable Chillers can also be found in Tables 2.6 and 2.7

Bring properly sized power leads and ground from a fused disconnect (installed by your electrician) to the unit. Use Fusetrons in the disconnect switch, sized according to the National Electrical Code recommendations listed on the electrical schematic mounted inside the control enclosure door.

- ELECTRICAL CONNECTIONS MUST COMPLY WITH ALL APPLICABLE ELECTRICAL CODES
- THE CHILLER MUST BE GROUNDED IN ACCORDANCE WITH NEC ARTICLE 250
- VOLTAGE MUST BE WITHIN +/- 10% OF NAMEPLATE RATING

### **3.2. PROCESS WATER CONNECTIONS - ALL MODELS**

---

#### **3.2.1 TO PROCESS**

The chilled water supply, labeled "TO PROCESS" is the outlet for the chilled water leading to the process being cooled.

#### **3.2.2 FROM PROCESS**

The chilled water return, labeled "FROM PROCESS" is the inlet leading from the process back into the chiller to be cooled and re-circulated.

#### **3.2.3 PROCESS WATER CONNECTION SIZING CONSIDERATIONS**

All external chilled water connections to the process must be of adequate size. See Tables 2.6 and 2.7 for sizing recommendations. The largest possible openings and passages should be provided for the flow of chilled water through platens, dies, molds or other pieces of equipment.

It is extremely important to have a minimum pressure drop external to the unit.

#### **3.2.4 PROCESS WATER BY-PASS VALVE**

Portable Chillers have a spring loaded by-pass valve used as a safety feature.

If the chilled water shut-off valves are inadvertently closed while the chiller is running, the factory set by-pass valve will open and allow a small amount of water to flow through the chiller. This protects the chiller from freeze-up and allows the other safety features to remain effective.

The by-pass valve should not be adjusted or tampered with.

Figure 2  
Condenser GPM Pressure Drop Curves

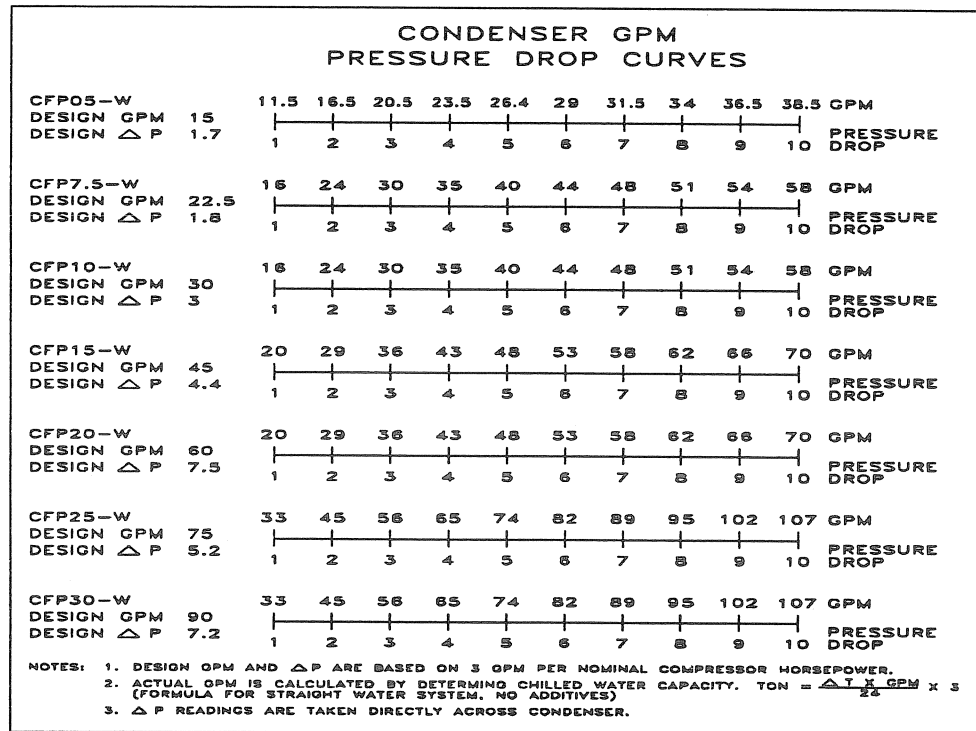
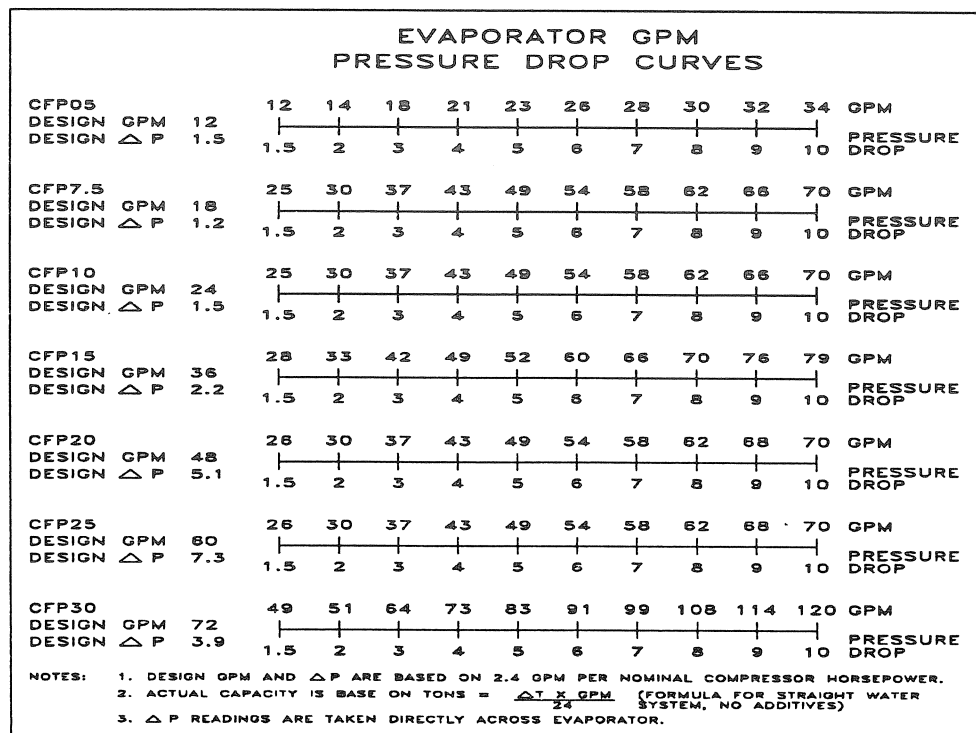

Figure 3  
Evaporator GPM Pressure Drop Curves



## INSTALLATION

### 3.2.5 WATER TREATMENT

Water treatment is an integral part of any piping system. In some locations, raw water may be used in the system without problem; in other locations, it will result in large deposits of scale and corrosion. Sterling Inc. recommends consulting a professional water treatment specialist for a water treatment plan tailored to meet the requirements of your process.

## **3.3. WATER-COOLED CONDENSER WATER SUPPLY**

---

- Water-cooled Portable Chillers can use either city or tower water as a cooling medium.
- All of the external piping and connections supplying and discharging water to and from the condenser should be full size.

### 3.3.1 CONDENSER WATER IN

The condenser water supply, located at the rear of the Portable Chiller, is the inlet for city or tower water.

Water should be supplied at a maximum temperature of 85°F and a minimum pressure of 25 psi. A water regulating valve is a standard feature in the condenser water supply line.

**THE WATER REGULATING VALVE IS FACTORY SET. IT SHOULD NOT BE ADJUSTED EXCEPT BY A QUALIFIED REFRIGERATION TECHNICIAN.**

Normal R-22 refrigerant condensing pressure with 85°F water at 25 psi entering condenser water temperature is 210 psi.

### 3.3.2 CONDENSER WATER OUT

The condenser water return located at the rear of the chiller is the outlet for water after it has passed through the condenser. It is connected to the tower inlet or to a sewer or other approved discharge receiver.

## **3.4. AIR-COOLED CONDENSER AIR SUPPLY**

---

- Air-cooled Portable Chillers use the surrounding air to cool the condenser.
- Install the chiller in an area where there is free passage of air for condensing and provisions for removal of heated air from the area. Do not locate this chiller in locations where steam, hot air or fume exhausts will be drawn into the chiller.
- Air-cooled condensers and filters must be cleaned frequently. Failure to do so will result in reduced capacity, increased operating costs and possible failure of the equipment. See Section 9 for cleaning instructions.
- Normal maximum R-22 refrigerant condensing pressure with 95°F air entering the condenser is 260 psi.

- The duct sizes in Figures 4 & 5 provide maximum capacity, do not reduce.
- Dampers to the outside must be closed whenever the fans or blowers are not operating.
- Support the ductwork from the building structure, not the chiller.
- Maximum total external static load should not exceed .3" WG.
- Provide 18" minimum clearance per side for the air intakes.
- Backdraft dampers must be installed in the cycling fan/blower discharge to prevent recirculation of discharge air.
- Discharge pants are required on CFP25-A and CFP30-A.

Figure 4  
Typical CFP05-A through  
CFP20-A Ductwork

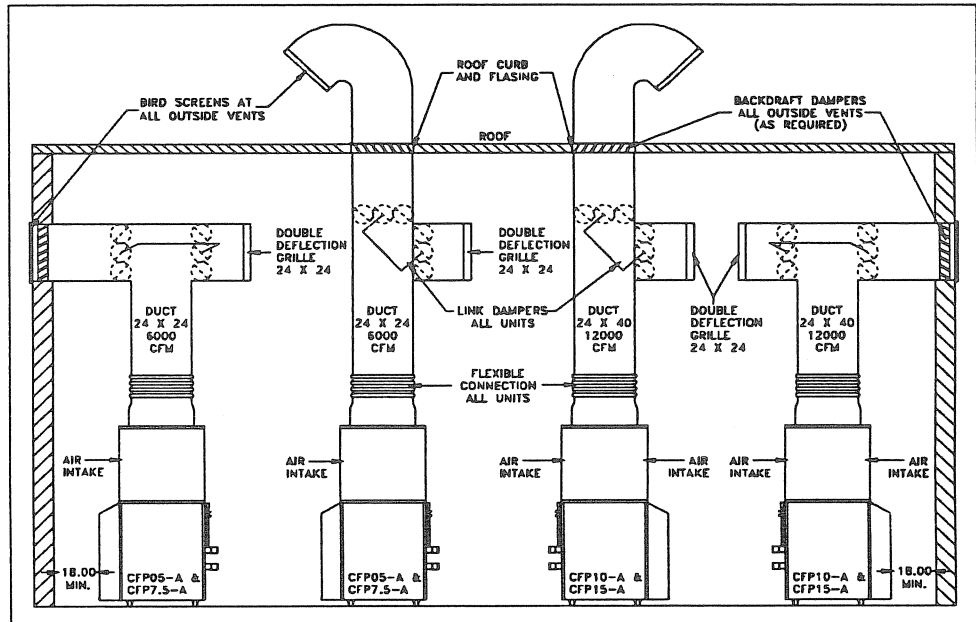
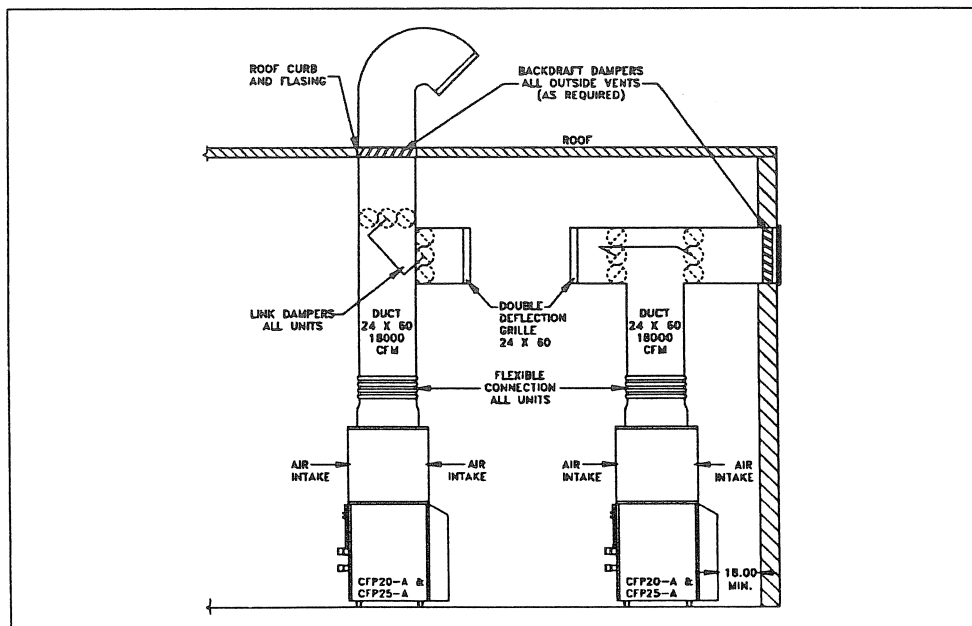

Figure 5  
Typical CFP20-A  
& CFP25A Ductwork



## INSTALLATION

### 3.4.1 CONDENSING AIR TEMPERATURE

Air-cooled Portable Chillers are designed to operate at a minimum condenser entering air temperature of approximately 60°F.

Operation of the equipment at a lower condenser entering air temperature can cause the low pressure cut out to shut down the unit due to the low refrigerant pressure.

It is recommended that the ambient temperature be maintained at 60°F or above.

## **3.5. MOTOR DIRECTION CHECK**

---

### 3.5.1 COMPRESSOR

Portable Chiller compressors will run properly in either direction.

### 3.5.2 WATER PUMP

Correct pump rotation is indicated by a positive pressure of 20 to 30 psi on the To Process pressure gauge. Check the pump curves in Figure 1 for Portable Chillers with special order pumps.

### 3.5.3 CONDENSER FAN

Air should be drawn through the condenser and discharged vertically from the chiller.

To change rotation direction:

- Disconnect and lock out power at the fused disconnect.
- Reverse any two motor leads at the power source.
- Do not switch leads at the motor or motor starters.

## **3.6. WATER RESERVOIR**

---

Portable Chillers are shipped with an antifreeze solution to protect against freeze-up damage in transit. The reservoir will have a solution of 70% water and 30% ethylene glycol during the summer months and 50% water and 50% ethylene glycol during the winter months.

During start-up and when additional solution is required, refer to the recommended ethylene glycol/water solution curve in Figure 8. Add a pre-mixed solution of industrial quality [not automotive] ethylene glycol and water to provide freeze protection to a temperature 20°F below the chiller's normal operating temperature.

For corrosion protection, an inhibitor suitable for the protection of the materials in the system should be added.

If straight water use is desired, contact the Sterling, Inc. Engineering Department.

Figure 6  
Typical Field Piping for Over-  
head Process Supply and  
Return

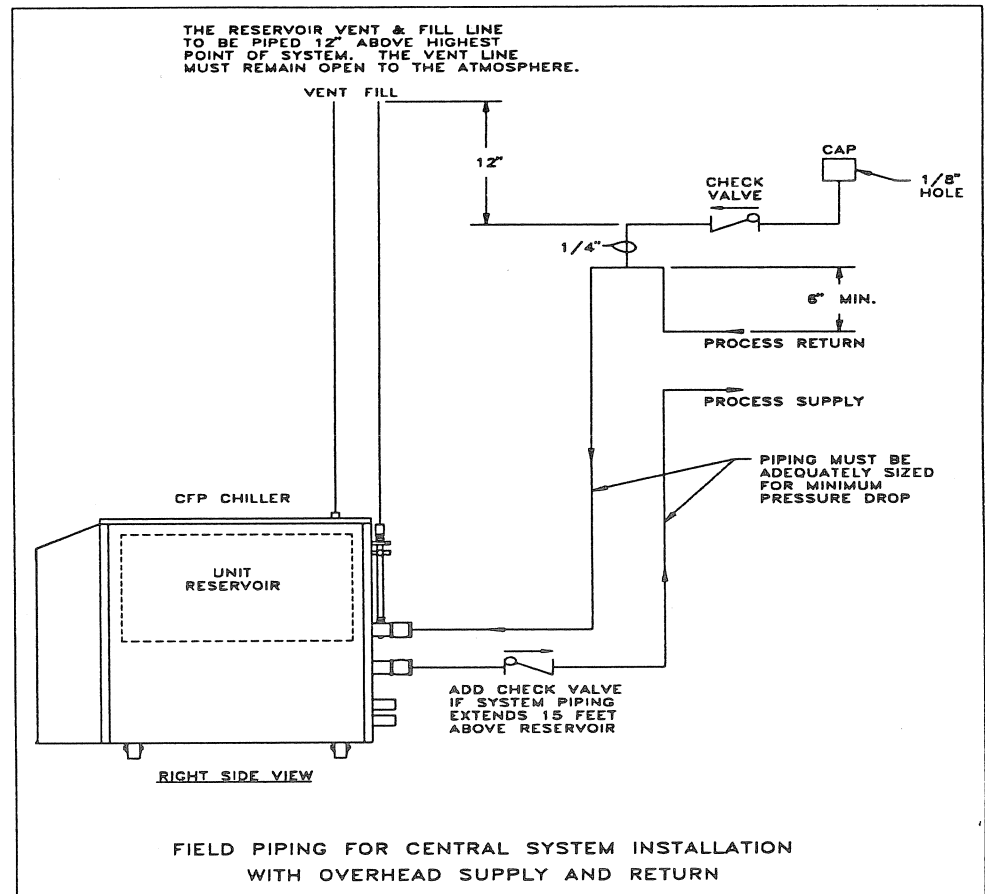

**DO NOT CONNECT MAKE UP WATER DIRECTLY TO THE CHILLED WATER RESERVOIR UNLESS AN APPROVED AUTOMATIC WATER MAKE UP SYSTEM IS INSTALLED. SEE NEXT SECTION .**

The reservoir is not designed to withstand water pressure in excess of 5 psi. The fill opening and vent line must be vented to the atmosphere for proper operation. The optional automatic make up system is described in the next section.

If your application has chilled water or process piping above the reservoir fill and vent level, install a standpipe to a point one foot above the highest point in the system.

In applications where the process or its piping is 15 feet or more above the reservoir, steps must be taken to prevent over-pressurization of the reservoir. This condition can occur on system shut down when the water in the system drains into the reservoir.

To prevent this, install a check valve in the unit "TO PROCESS" line and a vacuum breaker at the high point of the return "FROM PROCESS" line. See Figure 6 for details.

NOTE: The reservoir's reserve capacity can hold a maximum volume equal to 25 feet of 2 inch pipe.

### 3.7. AUTOMATIC WATER MAKE UP OPTION

The Portable Chiller may be connected to an automatic make up system if the optional package (float switch, pipe fittings, solenoid valve, pressure regulating valve and 1/2" NPT City Water Make Up connection) is factory installed.

Refer to Figure 7 for the additional components necessary for this installation. Your piping must provide backflow protection to protect city water supply and prevent over-pressurization of the reservoir.

**WARNING: PREVENT RESERVOIR OVER-PRESSURIZATION BY SETTING THE REQUIRED PRESSURE REGULATING VALVE TO LIMIT MAKE UP WATER PRESSURE TO LESS THAN 5 PSI.**

**THE RESERVOIR MUST REMAIN VENTED TO THE ATMOSPHERE.**

**WARNING: IF THE AUTOMATIC MAKE UP SYSTEM IS CONNECTED TO A CITY WATER SYSTEM, PROVISIONS MUST BE MADE TO PREVENT BACKFLOW CONTAMINATION. AN APPROVED BACKFLOW PREVENTER MUST BE INSTALLED IN ACCORDANCE WITH LOCAL CODES.**

Figure 7  
Optional City Water Make Up Piping Schematic

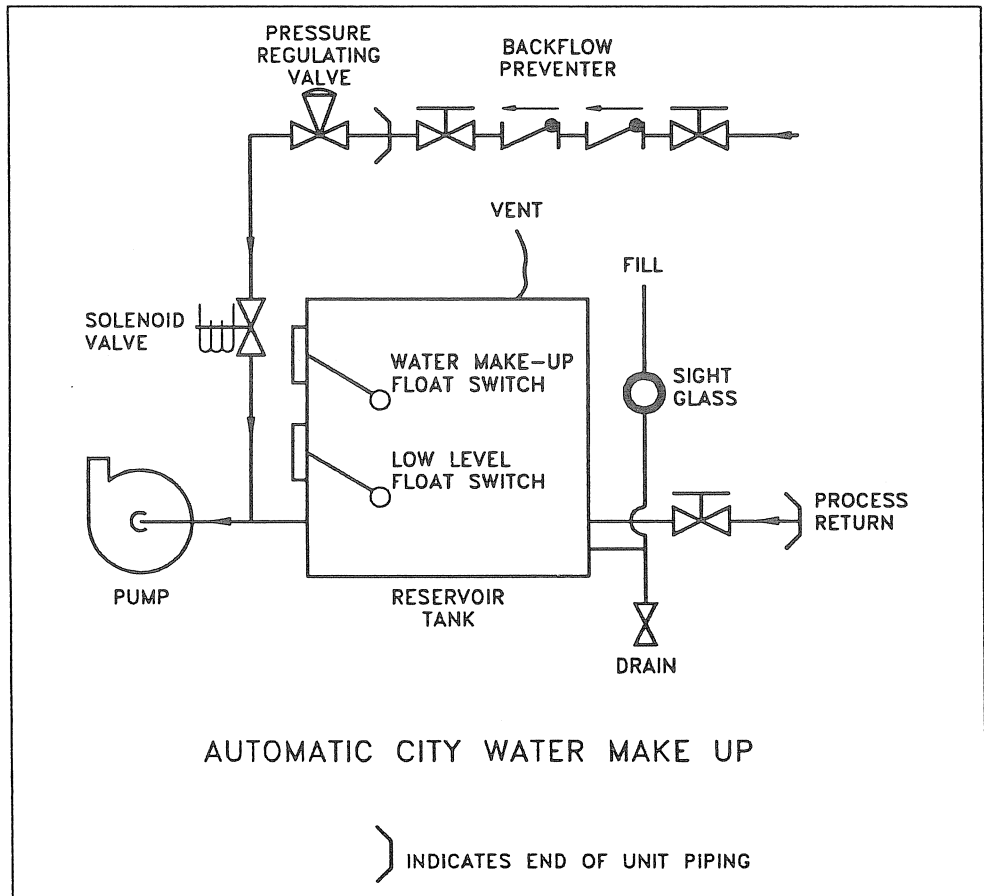



### 3.8. AVOIDING FREEZE-UP WITH AUTO MAKE-UP

**WARNING: THE ADDITION OF STRAIGHT CITY WATER INTO A GLYCOL/WATER MIXTURE WILL DILUTE THE SOLUTION AND EVENTUALLY LEAD TO SYSTEM FREEZE-UP. DAMAGE FROM FREEZE-UP IS NOT COVERED BY THE STERLING, INC. WARRANTY.**

To prevent system freeze-up in Automatic Make Up applications, a system to replenish the glycol must be used. Two methods are described below:

#### 3.8.1 Chemical Feeder

Use a chemical feeder to meter glycol into the make up water and maintain the desired water/glycol mixture. Contact the Sterling Sales Department for more information on this equipment.

#### 3.8.2 Make Up Reservoir

Glycol/water solution may be mixed in a tank and used as a source of make up fluid. Consult the Sterling Sales Department for more information on this piping configuration.

Figure 8  
Recommended Glycol/Water Solution Percentages for a Range of Process Temperatures

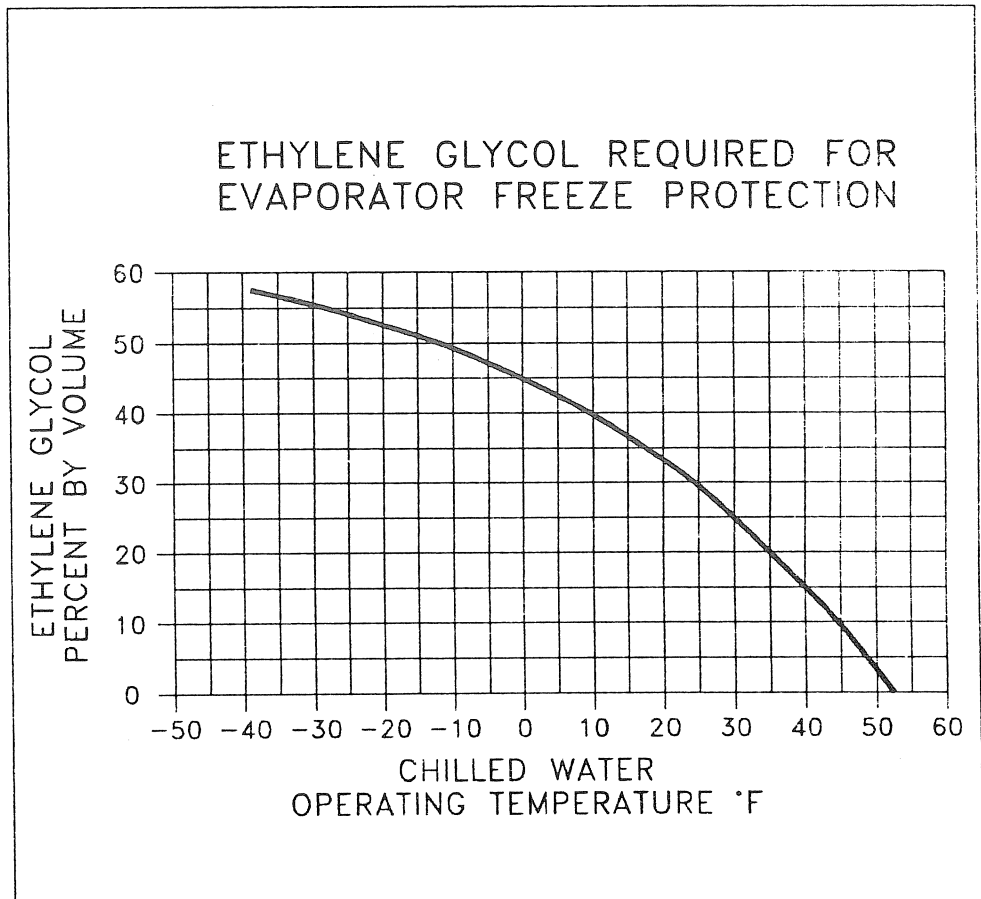

SEQUENCE OF OPERATION

Figure 10  
Two Pump CFP Portable Chiller  
Piping Diagram

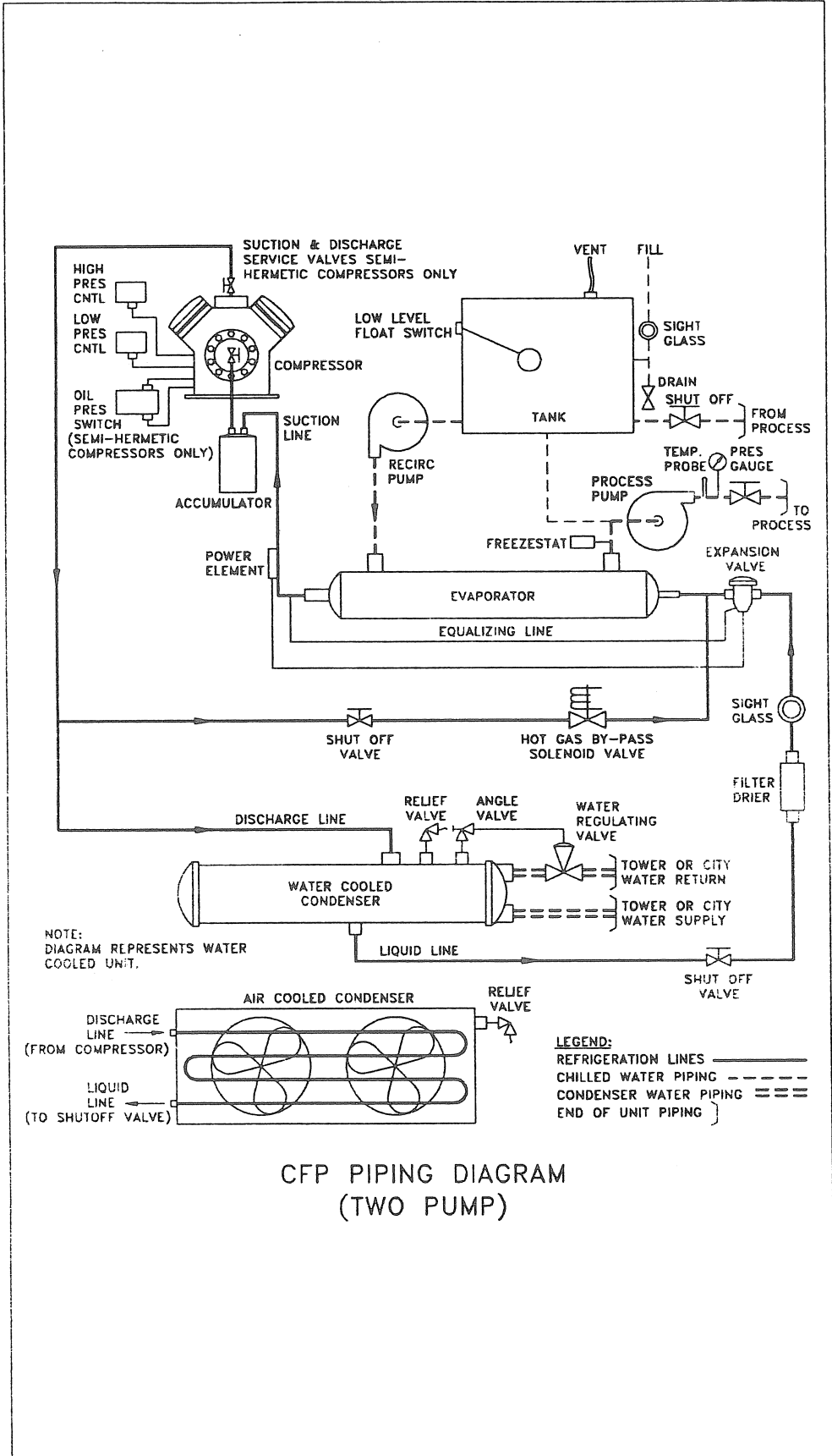
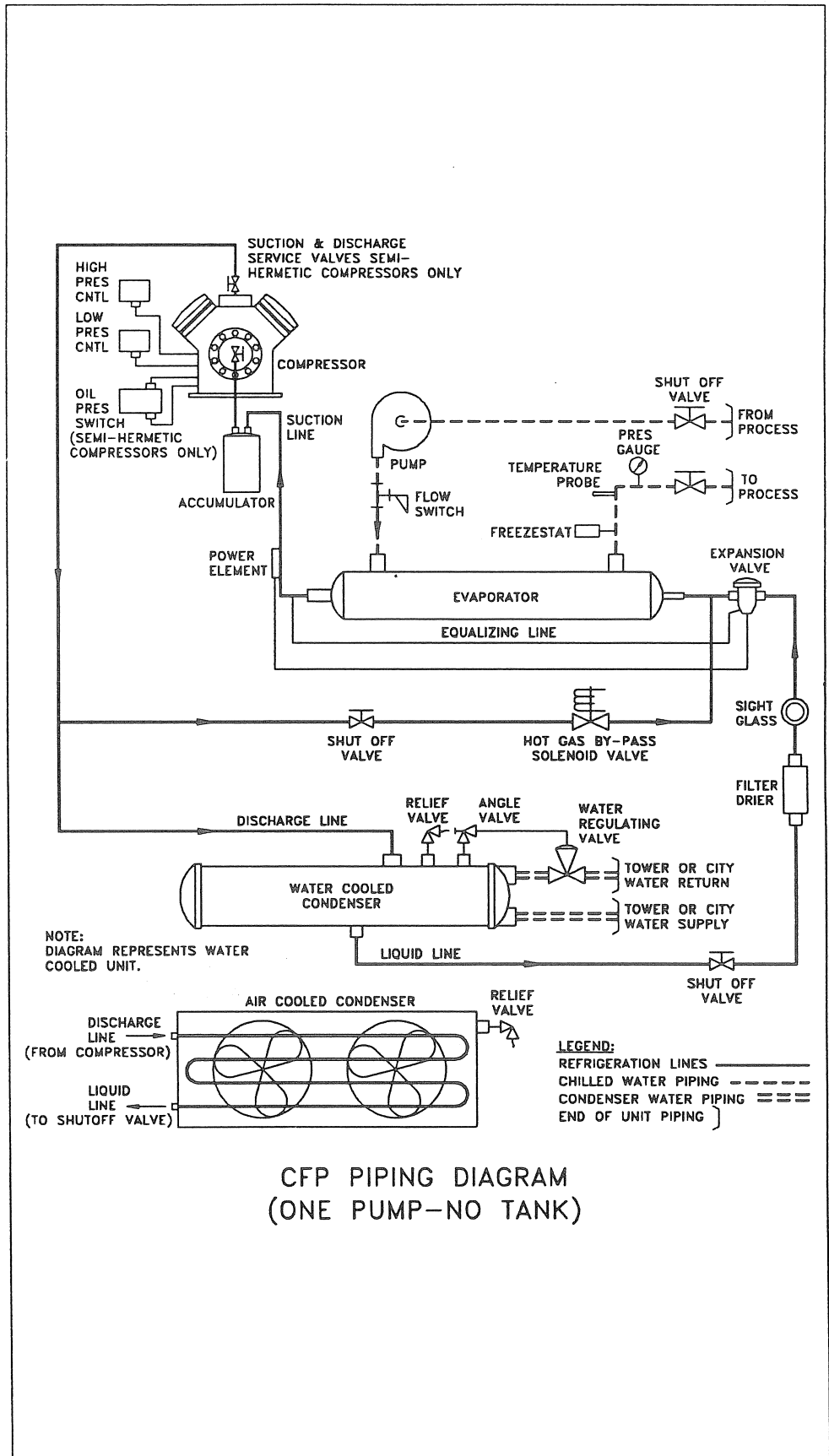

Figure 11  
One Pump, No Tank CFP Portable  
Chiller Piping Diagram



SEQUENCE OF OPERATION

Figure 12  
Two Pump, No Tank CFP  
Portable Chiller Piping Dia-  
gram

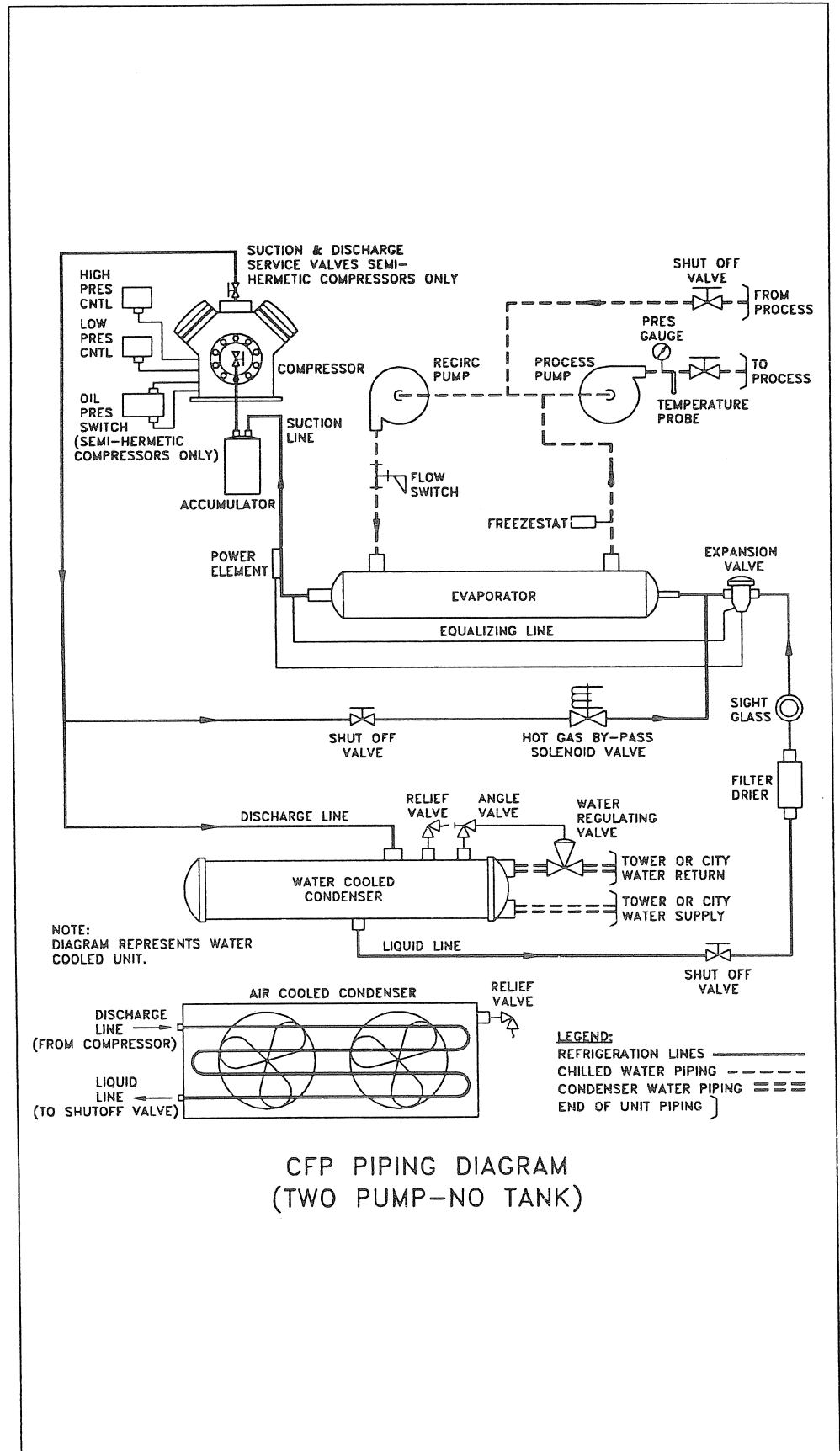
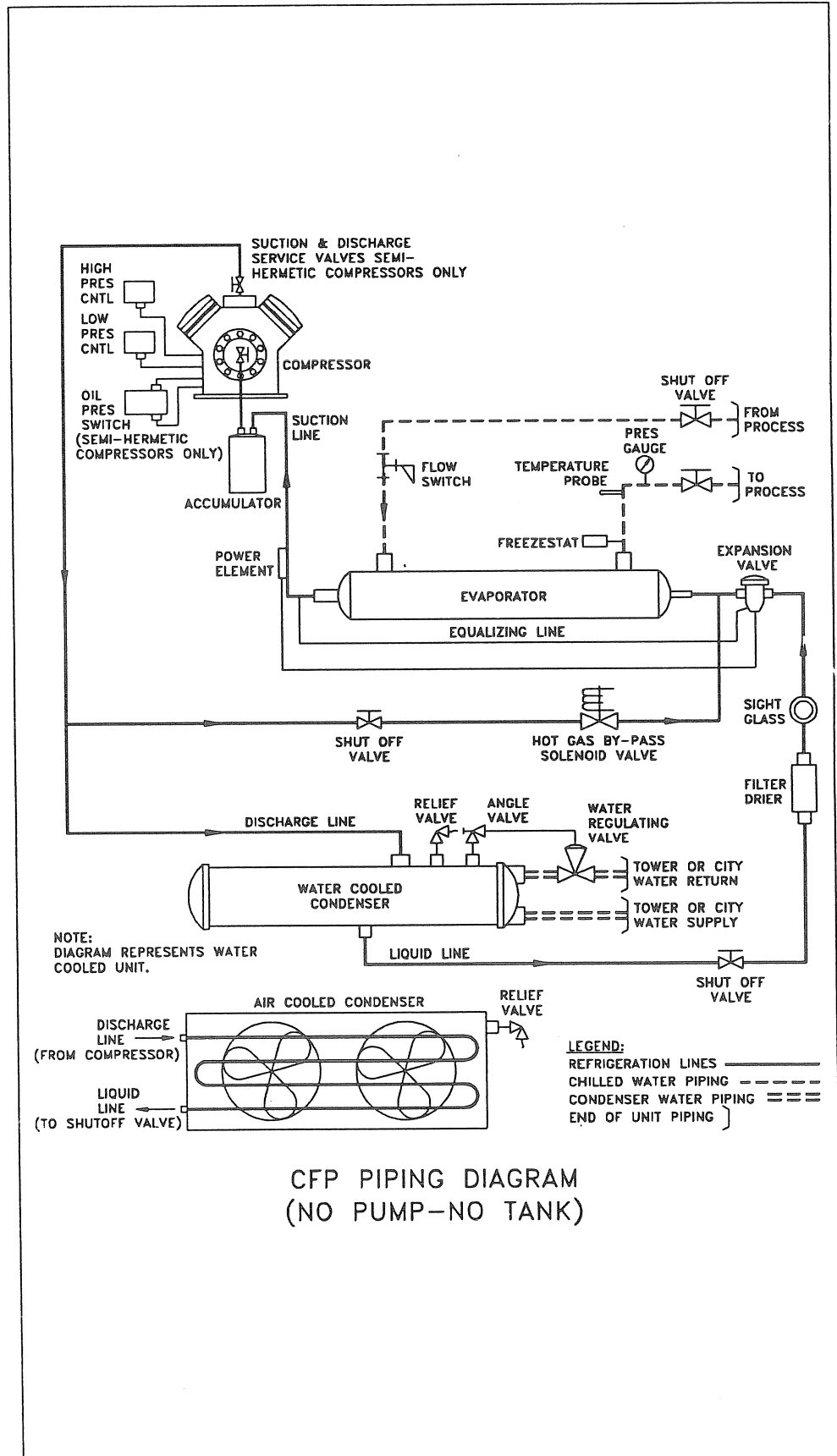

Figure 13  
No Pump, No Tank CFP  
Portable Chiller Piping Dia-  
gram



SEQUENCE OF OPERATION

Figure 14  
 Typical Water-Cooled CFP  
 Portable Chiller Electrical  
 Schematic.  
 Refer to the Schematic  
 Mounted in the Electrical  
 Enclosure for Unit-Specific  
 Details

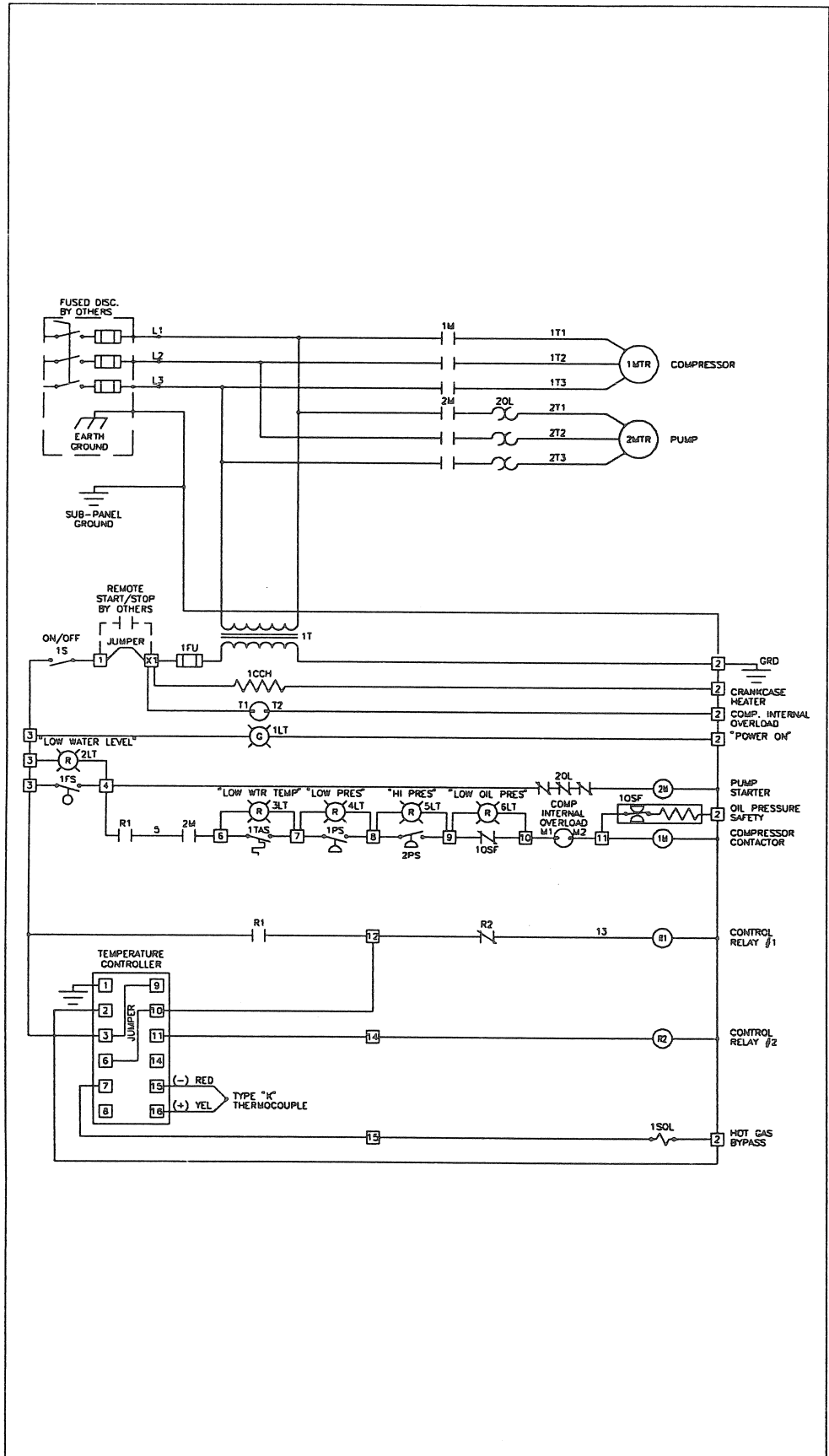
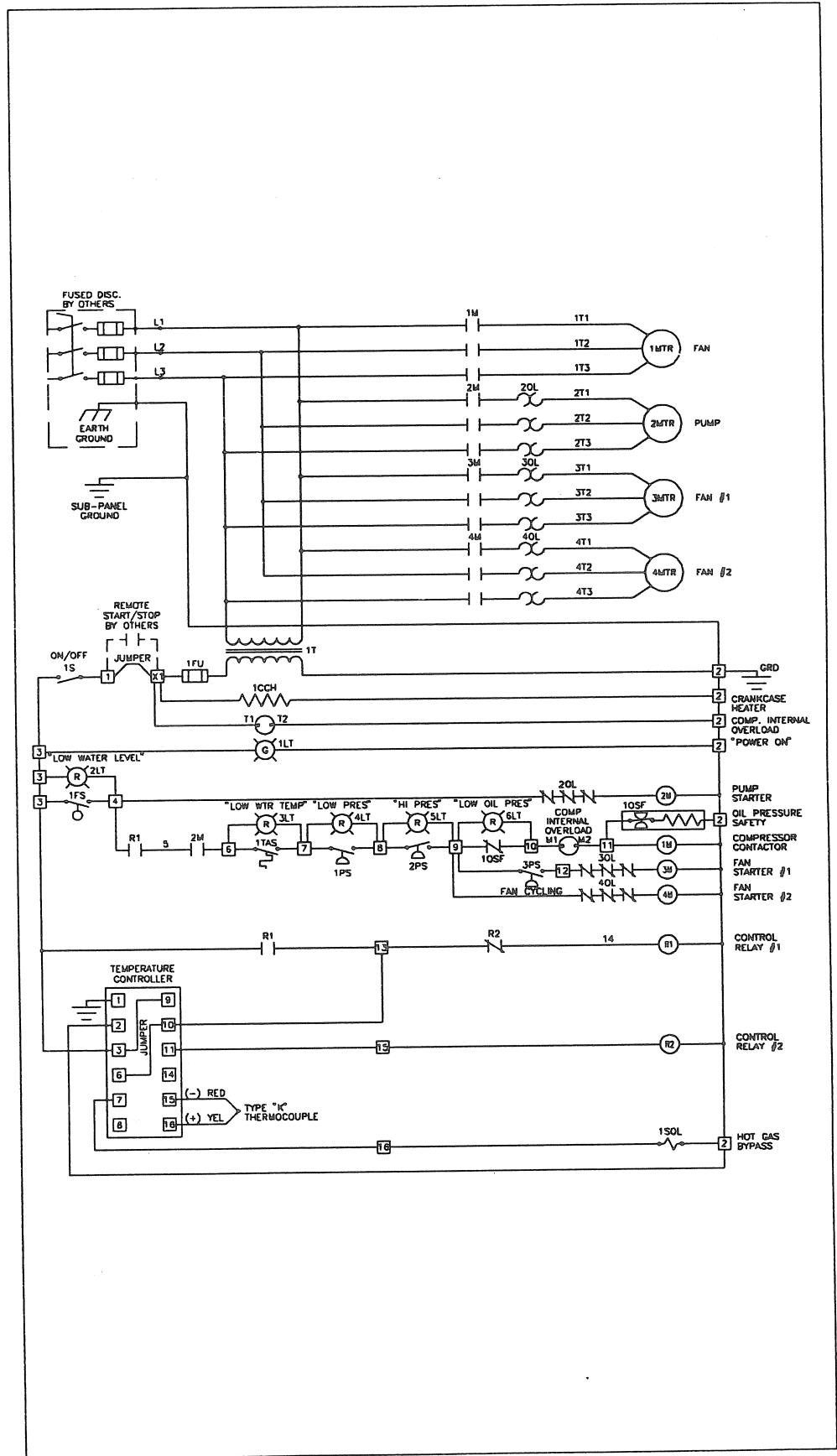

Figure 15  
 Typical CFP Air-Cooled Portable Chiller Electrical Schematic.  
 Refer to the Schematic Mounted in the Electrical Enclosure for Unit-Specific Details.



## 5. ELECTRO-MECHANICAL COMPONENTS

---

### 5.1. FREEZESTAT CONTROL

---

The Freezestat is a safety feature that will shut down the compressor should the chilled water temperature approach the freezing point. The chilled water pump will continue to run.

The freezestat cut out temperature is factory-set at 40°F. This is correct for a supply water temperature of 50°F - the rated capacity operating temperature.

If lower chilled water temperatures are desired, the process water must be mixed with industrial grade antifreeze (See Figure 8) to provide protection down to 20°F below the desired operating temperature. The freezestat cut out temperature can then be reset to a temperature 10°F below the desired operating temperature.

**CAUTION: FREEZESTAT ADJUSTMENT MUST BE PERFORMED BY A QUALIFIED REFRIGERATION SERVICE TECHNICIAN. THE STERLING, INC. PRODUCT WARRANTY DOES NOT COVER A SYSTEM FREEZE-UP.**

### 5.2. CRANKCASE HEATER

---

Portable Chillers have a crankcase heater wired through the control transformer which operates continuously whenever power is applied to the chiller.

**ENERGIZE THE CRANKCASE HEATER FOR 24 HOURS BEFORE INITIAL START UP TO DRIVE DISSOLVED REFRIGERANT FROM THE COMPRESSOR OIL. FAILURE TO DO THIS WILL DAMAGE THE COMPRESSOR.**

### 5.3. HIGH PRESSURE CUT OUT

---

This electro-mechanical safety feature opens the control circuit if the system condensing pressure exceeds 350 psi.

**THE HIGH PRESSURE CUT OUT IS A MANUAL RESET CONTROL. CALL A REFRIGERATION SERVICE TECHNICIAN TO ANALYZE THE PROBLEM AND TO RESET THE CONTROL.**



## **5.4. LOW PRESSURE CUT OUT**

---

This electro-mechanical safety feature prevents the evaporator temperature from dropping below a pre-set point.

It is factory set to open the control circuit at 30 psi for R-22. Low temperature chillers using R-502 are factory set to open the control circuit at 22 psi. This permits 20°F operation with a 70% water, 30% ethylene glycol coolant mixture.

This control automatically resets when the refrigerant pressure reaches 70 psi. Low temperature units reset at 57 psi.

## **5.5. OIL PRESSURE SWITCH - 15, 20, 25 & 30 HP Compressors**

---

This safety feature is a differential pressure switch that monitors crankcase oil pressure.

If the oil pressure should drop to an unsafe pressure level for more than two minutes, the switch will open the control circuit.

**THE OIL PRESSURE SAFETY SWITCH IS A MANUAL RESET CONTROL. CALL A REFRIGERATION SERVICE TECHNICIAN TO ANALYZE THE PROBLEM AND TO RESET THE CONTROL.**

## **5.6. FAN CYCLING SWITCH - AIR-COOLED MODELS ONLY**

---

### **5.6.1 CFP05-A and CFP7.5-A**

These models have one fan. The fan cycling switch turns on the fan when the condenser pressure reaches 275 psi and turns it off when the pressure drops below 200 psi.

### **5.6.2 CFP10-A Through CFP25-A**

These models have two fans. One turns on every time the compressor operates and will continue to run if the compressor is shut down by the high pressure control.

The fan cycling switch turns on the second fan when the condenser pressure reaches 275 psi and turns it off when the pressure drops below 200 psi.

### **5.6.3 CFP10-A Through CFP25-A with Optional Fan Cycling Switch**

Portable Chillers may be supplied with an optional fan cycling switch for applications with low ambient air temperatures. This switch cycles fans ON and OFF to maintain efficient condensing pressures.

If the optional fan cycling switches are installed, the primary fan (FAN 1) turns on at 250 psi and off at 200 psi. FAN 2 cycles on at 275 psi and off at 225 psi.

## 5.7. FLOAT SWITCH

This safety feature shuts down the system if the water in the reservoir falls below a safe level. Pump cavitation and freeze-up would otherwise occur.

## 5.8. REMOTE START/STOP INTERLOCK

An additional contact is provided to allow the remote starting or stopping of the Portable Chiller from a remote location.

To use this feature, remove the jumper between terminals X1 and 1 on TB2. Supply a switch or dry contact interlock connected in series between these two terminals.

Refer to the schematic glued inside the control enclosure door or the typical schematics in Figure 14.

Figure 16  
Typical CFP Portable Chiller  
Sub-Panel Layout

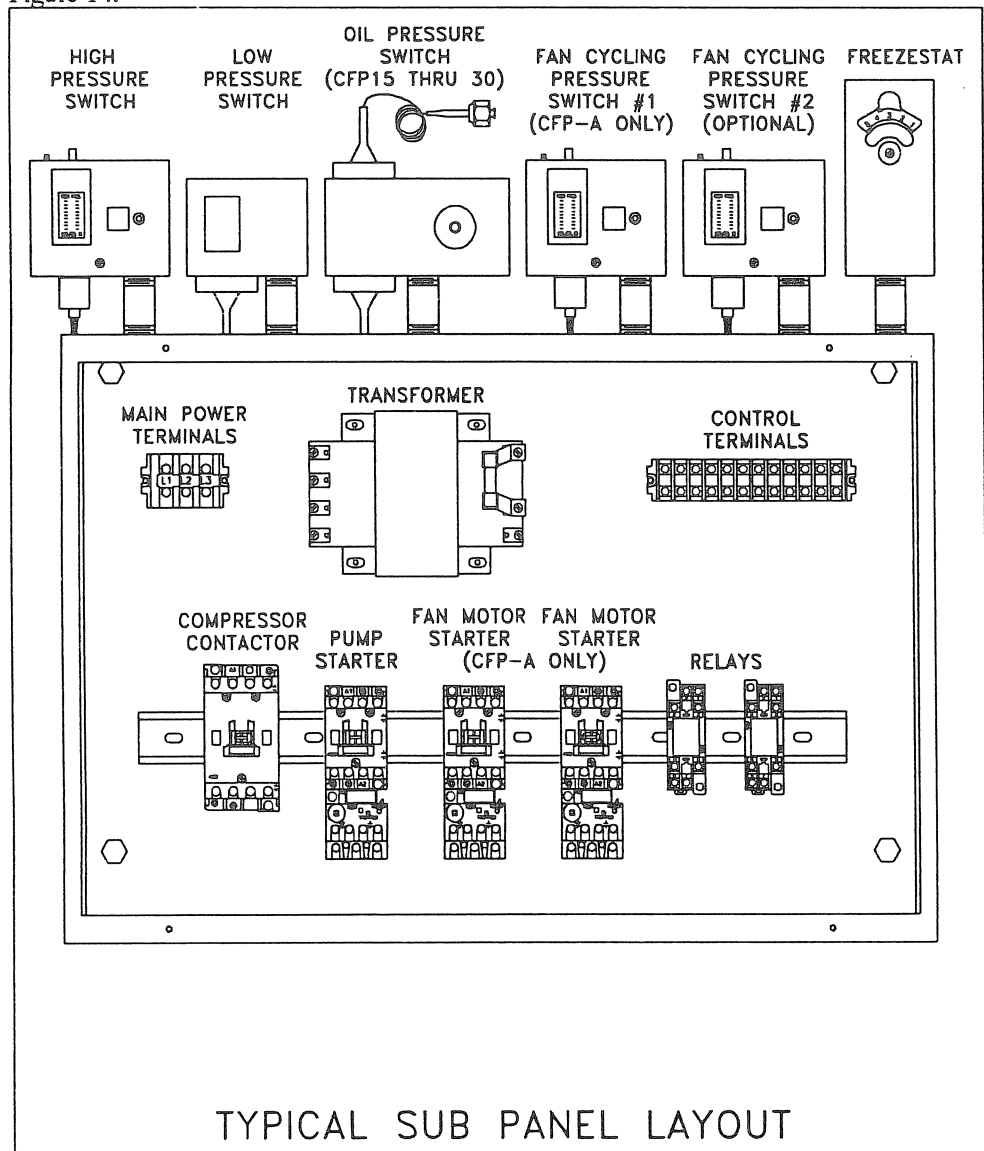

## 6. START-UP CHECK LISTS

---

### 6.1. INTRODUCTION

---

Follow the check lists below for the start-up of your new chiller. These lists assume the installation information elsewhere in this manual has been read and followed. New chillers should be started up and checked by a qualified refrigeration service technician.

### 6.2. WATER-COOLED CHILLER START-UP CHECK LIST

---

- Check the shipping papers against the serial tag to be sure chiller size, type and voltage is correct for the process that will be controlled.
- Check the transformer primary voltage connections to be sure they are configured for the electrical power you are using. The voltage at the main power connection must read within +/-10% of the voltage listed on the serial tag. Electrical connections must conform to all applicable codes.
- The chilled water To-Process and From-Process connections should be completed.
- The chilled water supply valve on the chiller must be open.
- Be sure the reservoir tank and chilled water circuit piping are filled to the full mark with a water/glycol mixture. The water/glycol mixture should provide for freeze protection to at least 20°F below the desired leaving water temperature.
- The tower or city condenser-cooling WATER IN and WATER OUT connections should be completed and an adequate supply of condenser water must be available.
- Connect the main power to the unit and bump-start it to check for proper rotation direction. If the pump is operating backwards, reverse any two main power leads at the incoming terminal block. The crankcase heater should be ON for at least 24 hours before start-up to force dissolved refrigerant gas from the compressor oil.
- Check your work and proceed to Start-Up in the next section.

### 6.3. WATER-COOLED CHILLER START-UP

---

- Turn ON the chiller and put it under a process load.
- Set the Control to the desired process temperature using the shift, set up or down arrow buttons.
- Adjust the Freezestat Cut-Out dial, located above the electrical enclosure, to 10°F below the desired process temperature.
- Check the pump amp draw and pump pressure. The amp draw reading must be within the running load and service factor amps.

## START-UP CHECK LISTS

- Operate the chiller, looking for leaks and listening for unusual noises or vibrations that could indicate improper operation.

### **6.4. AIR-COOLED CHILLER START-UP CHECK LIST**

- Check the shipping papers against the serial tag to be sure chiller size, type and voltage is correct for the process that will be controlled.
- Check the transformer primary voltage connections to be sure they are configured for the electrical power you are using. The voltage at the main power connection must read within +/-10% of the voltage listed on the serial tag. Electrical connections must conform to all applicable codes.
- The chilled water To-Process and From-Process connections should be completed.
- The chilled water supply valve on the chiller must be open.
- Be sure the reservoir tank and chilled water circuit piping are filled to the full mark with a water/glycol mixture. The water/glycol mixture should provide for freeze protection to at least 20°F below the desired leaving water temperature.
- The air-cooled condenser should have an adequate supply of air for proper operation.
- Connect the main power to the unit and bump-start it to check for proper rotation direction. If the pump is operating backwards, reverse any two main power leads at the incoming terminal block. The crankcase heater should be ON for at least 24 hours before start-up to force dissolved refrigerant gas from the compressor oil.
- Check your work and proceed to Start-Up in the next section.

### **6.5. AIR-COOLED CHILLER START-UP**

- Turn ON the chiller and put it under a process load.
- Set the Control to the desired process temperature using the shift, set and up or down arrow buttons.
- Adjust the Freezestat Cut-Out dial, located above the electrical enclosure, to 10°F below the desired process temperature.
- Check the pump amp draw and pump pressure. The amp draw reading must be within the running load and service factor amps.
- Operate the chiller, looking for any leaks and listening for unusual noises or vibrations that could indicate improper operation.

# 7. CONTROL OPERATION

## 7.1. THE MICROPROCESSOR CONTROL

The control is an easy-to-operate microprocessor based PID control. When the process reaches the Set Point, the PID control in the cycles the hot-gas bypass valve to maintain the proper leaving water temperature.

The control has been fully factory tuned and tested. The control is configured at the factory and needs no adjustment. Set the desired process temperature Set Point and the control does the rest.

Figure 17  
The Microprocessor Control

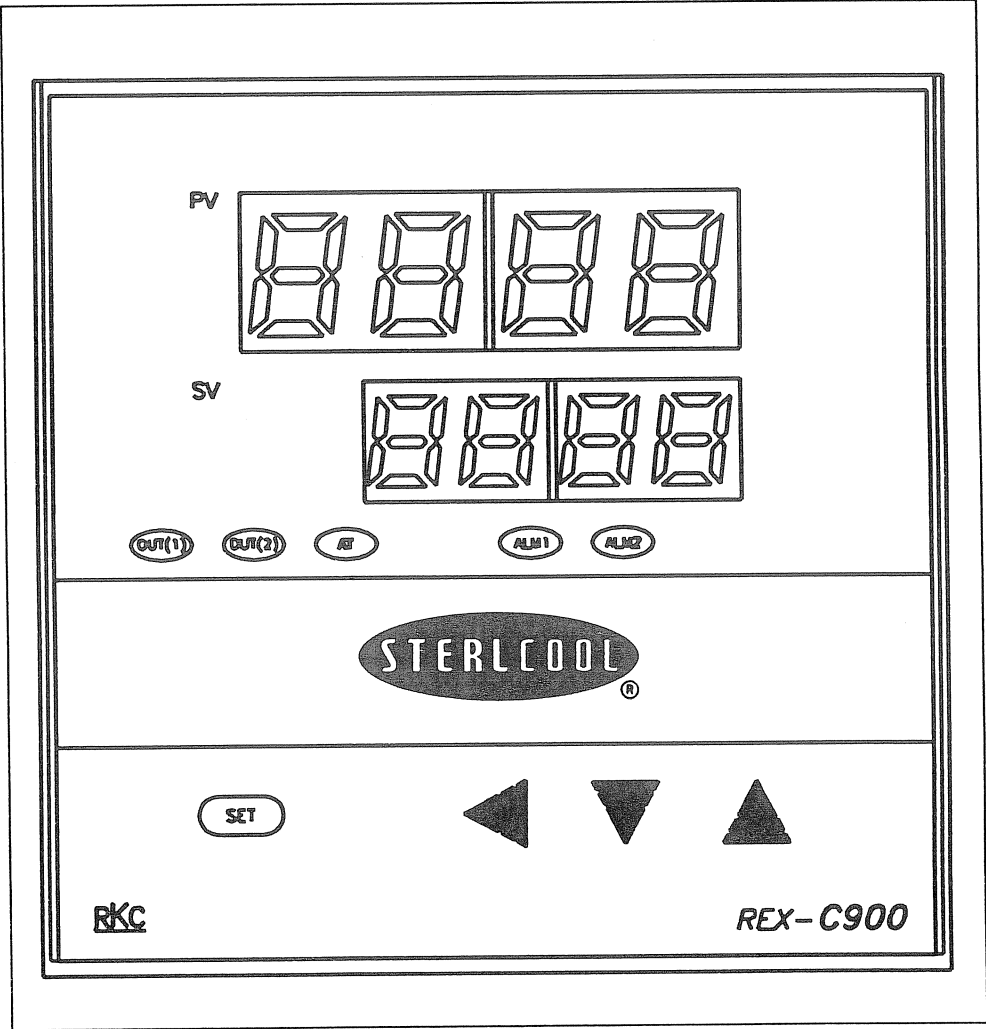

## 7.2. CONTROL OPERATION RANGE

---

Standard R-22 Portable Chillers	Optional R-502 Portable Chillers
20°F to 70°F	0°F to 30°F

## 7.3. CONTROL PANEL INDICATOR LIGHTS

---

### 7.3.1 GREEN PV LED

The large green numeric LED display on the face of the control displays the actual process temperature at the To-Process thermocouple.

### 7.3.2 ORANGE SV LED

The orange LED display on the face of the control displays the desired process Set Point.

### 7.3.3 OUT (1) LED

The green OUT (1) LED lights whenever the hot-gas bypass feature is operating.

### 7.3.4 OUT (2) LED

The yellow OUT (2) LED is not used in the Portable Chiller microprocessor control.

### 7.3.5 AT LED

The green AT (Auto-Tune) LED flashes during the Auto-Tune sequence. The microprocessor control has been tuned at the factory; no field auto-tuning is needed.

### 7.3.6 ALM 1 LED

The ALM 1 red LED lights whenever the temperature at the To-Process thermocouple rises 2°F or more above the process Set Point. The compressor will turn on and run until the process Set Point has been achieved. This +2°F control point is factory set for proper compressor operation.

### 7.3.7 ALM 2 LED

The ALM 2 red LED lights whenever the temperature at the To-Process thermocouple drops 2° F or more below the process Set Point. The compressor is shut down until the process temperature is regained.

## **7.4. CONTROL PUSH-BUTTONS - See Figure 17**

---

### **7.4.1 SET BUTTON**

This button is used along with the arrow buttons to set the process set point. When the Set button is pressed, the four orange set point LEDs glow. The brightest LED (on the right) may then be adjusted with the up or down arrow buttons. Press the left arrow button to highlight the next LED to the left. When the desired process set point is displayed, press the Set button again to accept the new set point.

- If the Set button is pressed, but no attempt is made to change the set point, the display will return to the original set point.
- The microprocessor control will not accept a set point outside of the control's operating range.

### **7.4.2 DOWN ARROW BUTTON**

This button lowers the value of the currently highlighted SV LED.

### **7.4.3 UP ARROW BUTTON**

This button raises the value of the currently highlighted SV LED.

### **7.4.4 LEFT ARROW BUTTON**

This button highlights each SV LED in succession. Press it once to move one LED to the left. The highlight will wrap to the starting point after the leftmost LED is highlighted.

## **7.5. MICROPROCESSOR CONTROL OPERATION**

---

To Change Set Point:

- Press the Set button.
- Press the up or down arrow button to change the highlighted LED to the desired value.
- Press the left arrow button to highlight the next LED to the left if desired. Use the up or down arrow buttons to change the highlighted LED's value.
- Press the Set button to accept the new setpoint. The new set point will be displayed. To abort the change, do not press the set button; the previous set point will return.

## **8. GRAPHIC PANEL**

---

### **8.0.1 INTRODUCTION**

This Section describes the indicator lights installed on the graphic control panel. Refer to Figure 18 for the indicator light locations.

### **8.0.2 HIGH REFRIGERANT PRESSURE LIGHT**

This indicator lights if the condensing pressure exceeds 350 psi. The chiller will go into an idle mode until the High Pressure Cut Out is manually reset. Call a qualified refrigeration service technician for service.

### **8.0.3 LOW REFRIGERANT PRESSURE LIGHT**

This indicator lights if the refrigerant pressure drops below a safe level. The compressor will stop and remain off until the pressure reaches 70 psi. The light will go out and the chiller will then resume operation automatically.

### **8.0.4 LOW OIL PRESSURE LIGHT**

This indicator light, installed on chillers with 15 horsepower compressors and larger, lights if compressor oil pressure drops to a dangerously low pressure level. After two minutes of low oil pressure, the Portable Chiller will shut down. This is a manual reset control. Call a qualified refrigeration service technician for repairs.

### **8.0.5 LOW WATER LEVEL LIGHT**

This light is illuminated when the float switch in the reservoir senses that the water/glycol level has dropped below an acceptable level. Add enough water/glycol mixture to fill the tank to the operating level, or check the operation of the automatic water make up if one is installed. Use a mix that will provide freeze protection to at least 20°F below the process temperature.



**8.0.6 LOW WATER TEMPERATURE LIGHT**

This indicator lights if the chilled water drops below the Freezestat setting. This prevents possible system freeze-up. The compressor will shut off and the chilled water pump will operate until the temperature rises above the Freezestat setting.

**Warning: The Sterling warranty does not cover damage due to system freeze-up. A proper Freezestat setting will prevent freeze-up.**

**8.0.7 SYSTEM POWER LIGHT**

This indicator lights whenever the power switch is in the ON position and the control circuit is energized.

Note: The crankcase heater is energized whenever main power is applied to the chiller. The position of the power switch does not affect the operation of the crankcase heater.

Figure 18  
Portable Chiller Graphic Panel

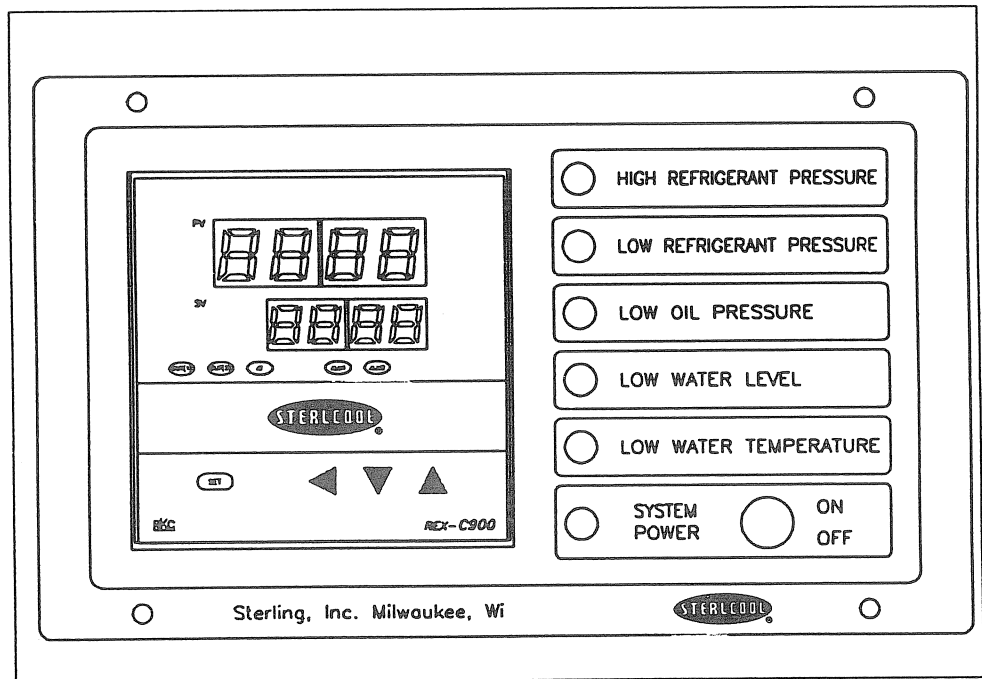

## 9. ROUTINE MAINTENANCE

---

### 9.1. LUBRICATION

---

Every three months, grease all fan bearings, fan motors, and pump motors that do not have permanently sealed bearings. Remove grease relief plug (motors only) before adding grease. Failure to do so may result in dislodging the bearing grease retainer which will eventually cause bearing failure.

Compressors are hermetically sealed and no oiling is required.

### 9.2. OPTIONAL AIR-COOLED CHILLER FILTERS

---

The use and cleaning of optional filters is important to keep your Portable Air-Cooled Chiller operating at peak capacity in contaminated air. Clean them whenever they are dirty.

To clean, slide the filter from its mount and hose down with clean water. If the dirt is heavy, use a mild detergent and rinse well. Allow the filter to dry completely before replacing it on the chiller. Spare filters are recommended. Use a spare while cleaning the other.

Blowing out a filter with compressed air does not satisfactorily clean it and may damage the filter.

**WARNING: Sterling Inc. highly recommends the use of air filters.**

### 9.3. CONDENSER MAINTENANCE

---

Dirty condenser heat exchange surfaces reduce system capacity.

#### 9.3.1 Air-Cooled:

Brush or vacuum light dirt accumulations. Avoid bending or damaging the fins. Heavy soil accumulations on the coil require professional steam cleaning. Washing from the outside will only make matters worse.

#### 9.3.2 Water-Cooled:

Remove dirt in the condenser tubes with a nylon tube brush.

Mineral deposits can be removed by circulating liquid de-scaling solution through the water side of the condenser. Follow the directions on the container.

The refrigerant side is sealed and requires no routine maintenance.

# 10. TROUBLESHOOTING CHECK LIST

PROBLEM	CAUSE	SOLUTION
Unit will not Run	No power.	Check main disconnect fuses, wiring, and power lead to unit.
	Wrong voltage supplied to the unit.	Voltage must be within plus or minus 10% of nameplate rating.
	Defective on/off switch.	Replace.
	Control circuit fuse blown.	Replace, check transformer. Check crankcase heater.
	Defective control transformer.	Replace.
	Reservoir float switch circuit open.	Add anti-freeze solution as required to bring liquid level up to normal.
	Pump motor off on overload.	Reset and test.
Pump runs, compressor cycles at short intervals.	Freeze control setting too high.	Lower set point to 10°F below desired leaving water temperature.
The leaving water temperature is too high.	Improper water/glycol solution.	Be sure the antifreeze mixture protection is right for the process.
	Defective freezestat control.	Replace
	Refrigerant charge is low.	Call service to find and repair the leak.
	The refrigerant pressure switch is set too high.	Call service to adjust the pressure switch pressure control to 30 psi R-22 cut out and 50 psi cut in.
Pump pressure low (refer to curves for normal pressure for various pumps).	Pump running in reverse.	Verify proper rotation; if incorrect, reverse any two main power leads. Re-verify for correct rotation.
	Check for foreign matter.	Clean the system.

TROUBLESHOOTING CHECK LIST

PROBLEM	CAUSE	SOLUTION
Pump runs; compressor will not.	Freeze control set higher than liquid in system.	Lower freeze control temperature to 10°F below desired leaving temperature.
	Defective freezestat.	Replace.
	Refrigerant low.	Check the refrigerant charge.
	Pressure switch contacts open.	Sight glass should be clear while compressor runs. Call for service if bubbling or foaming.
	Refrigerant high pressure cut out switch contacts open.	Clean the air filters. Check condenser fans for proper rotation. Check for dirty condenser. Check for condenser air obstruction
	Fan motor out on overload.	Reset and test.
	Defective fan cycling control.	Replace.
	Defective fan motor.	Repair or replace.
	Compressor internal overload open. Allow time to cool and reset.	Check for high/low voltage. Must be within plus or minus 10% of nameplate rating. Check for poor compressor electrical connections.
	Compressor contactor holding coil open.	Repair or replace.
	Defective pump motor interlock to compressor control circuit.	Repair or replace.
	Broken wire in the compressor control circuit.	Locate and repair.
Pump pressure is too high.	Restricted water flow	Check for partially closed valves etc. Be sure all lines are properly sized.
Unit runs continuously, but not enough cooling power.	Restricted condenser air flow.	Clean filters. Clean condenser.
	Unit low on refrigerant.	Call service.
	Inefficient compressor.	Call service.
	Unit under-sized for application.	Call sales representative.