

/ Marley HP7000 Fan Clamped Blade Shank – 192" thru 240" /

User Manual 01-1139A

Fan Components

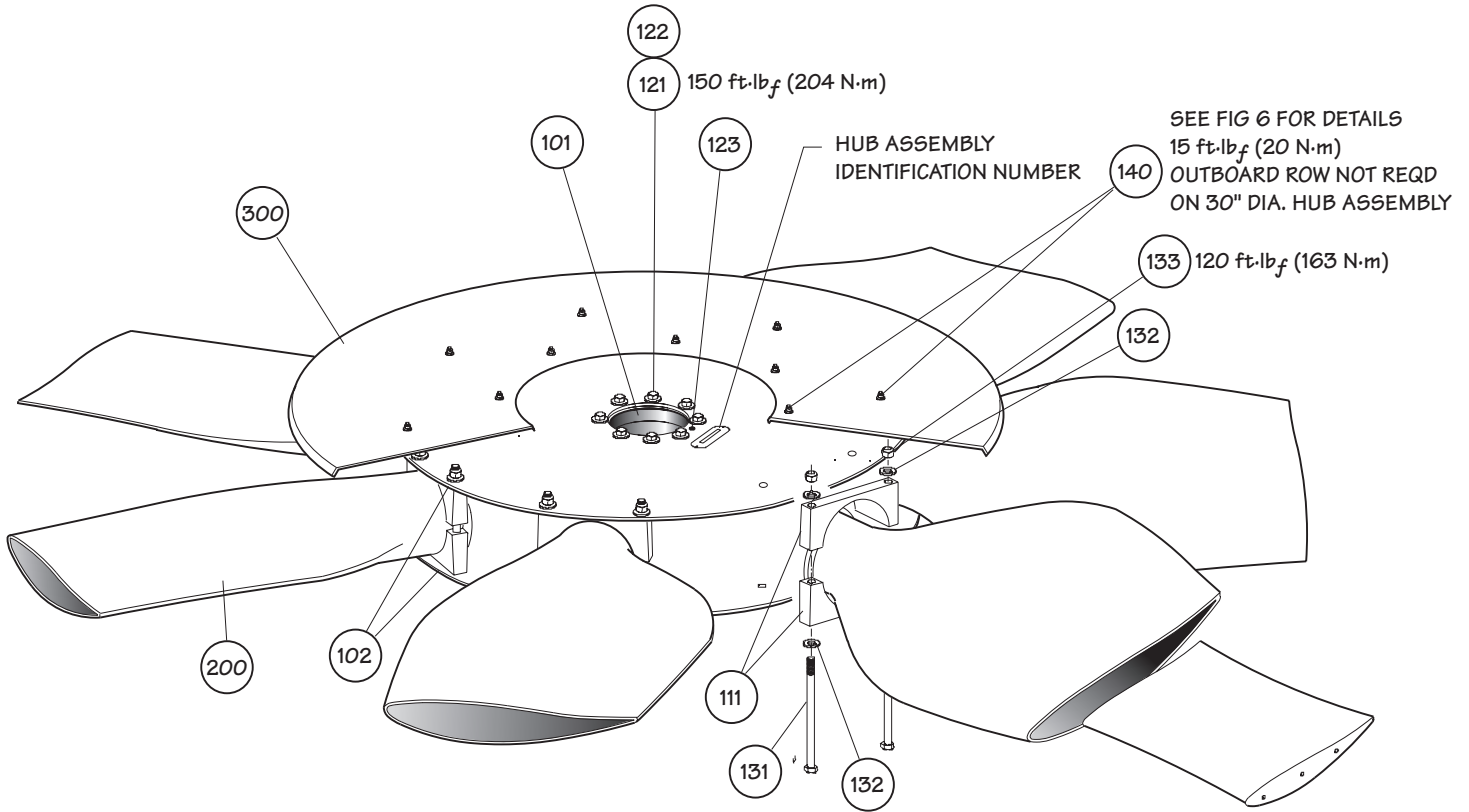

- 100 Hub**
- 101 Hub Center
- 102 Hub Plate
- 110 Kit-Blade Clamp**
- 111 Blade Clamp
- 120 Kit-Center Hub Hardware**
- 121 Cap Screw 5/8"
- 122 Flat Washer 5/8"
- 123 Pin 1/2"
- 130 Kit-Blade Clamp Hardware**
- 131 Machine Bolt 3/4"
- 132 Flat Washer 3/4"
- 133 Locking Hex Nut 3/4" or Hex Nut 3/4" and Lock Washer 3/4"
- 134 Thread Lubricant
- 140 Kit-Hub Cover Hardware**
- 141 Machine Bolt 3/8"
- 142 Flat Washer 3/8"
- 143 Lock Washer 3/8"
- 144 Hex Nut 3/8"
- 145 Locking Hex Nut 3/8"
- 146 Spacer
- 150 Kit-Balance Hardware**
- 160 Manual**
- 200 Blade**
- 300 Hub Cover**

Figure 1 – Typical Fan Assembly

actual component appearance may vary

Order No. _____

Trial Pitch Angle _____

Final Pitch Angle _____

Speed-rpm _____

Contract hp _____

Fan Hub Installation

The following instructions detail the process for installing a Marley HP7000 Fan on a Marley Geareducer® with a tapered fan (output) shaft and bolted fan hub retention. Installation on other gear reduction units may be different. Contact your Marley sales representative for supplemental instructions if required.

1—Remove the retention plate and hardware from the top of the Geareducer shaft. Thoroughly clean the fan shaft, fan shaft key, and the fan hub center bore to remove any debris and/or protective coatings. After cleaning, apply a coat of anti-seize compound to the top 5" (130mm) of the fan shaft.

2—Prior to hub installation, fully seat the key in the fan shaft keyway. The key is a tight fit across the width and must never be altered.

3—Raise the fan hub above the fan shaft for installation. Slowly lower the hub onto the shaft with the keyways properly aligned. Make certain the key does not slide down during installation. Stake the key in the keyway with a center punch if necessary.

The fan shaft key should be approximately centered in the engaged portion of the hub when engaged on the shaft. Verify the center hub is fully seated by visual inspection.

4—The hub retention plate will sit on top of the spool. Discard the retention bolts that come with the Geareducer. New retention bolts are provided with the hub cover hardware kit. Torque bolts to 50 ft·lb_f (68 N·m).

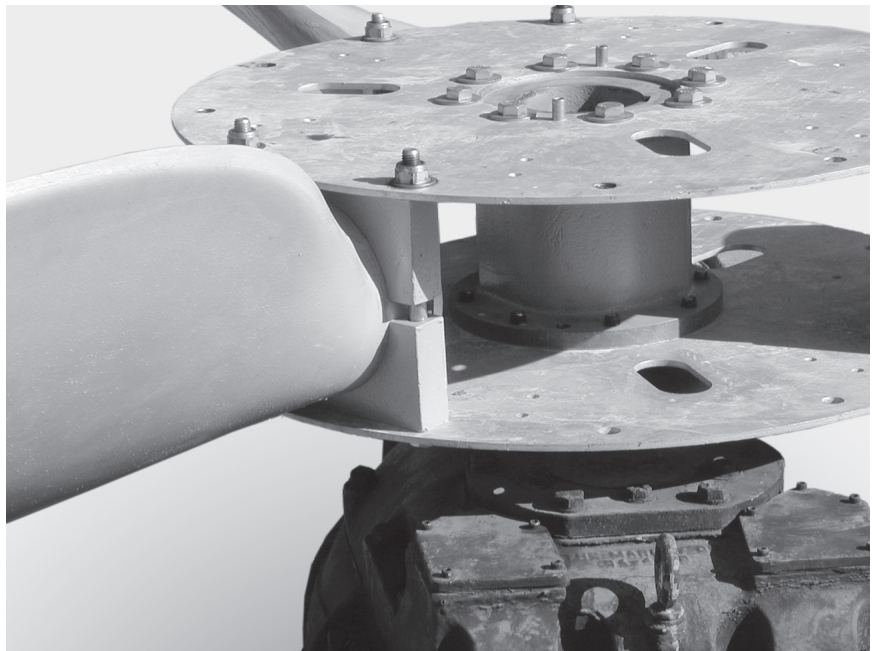

Figure 2

Fan Blade Installation

Marley HP7000 fan blades are manufactured to equal moment weight and blade clamps to equal static weight. The blades and clamps can be installed in any position without affecting fan balance.

Note

At the end of the blade shank on a nameplate is inscribed a letter code (i.e. "A" or "B" etc.). When installing or replacing blades use only blades with the same letter code.

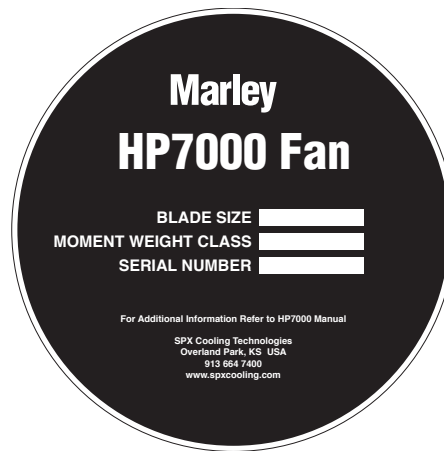

Figure 3–Blade Nameplate

1–Lubricate the $\frac{3}{4}$ " bolt and $\frac{3}{4}$ " hex-nut threads with thread lubricant. Set the hardware aside.



Figure 4

2—Remove one set of blade clamps from the hub assembly. Blade clamps are installed on the hub assembly at the factory with spacers for shipping purposes. Remove and discard the spacers. Position the blade clamps around the shank of a blade with the machined-face end of the blade clamp against the blade safety shoulder. See **Figure 5**. Large nylon cable ties can be used to hold blade clamps on the blade during installation providing easier assembly.

3—Insert the blade with blade clamps around the shank and with

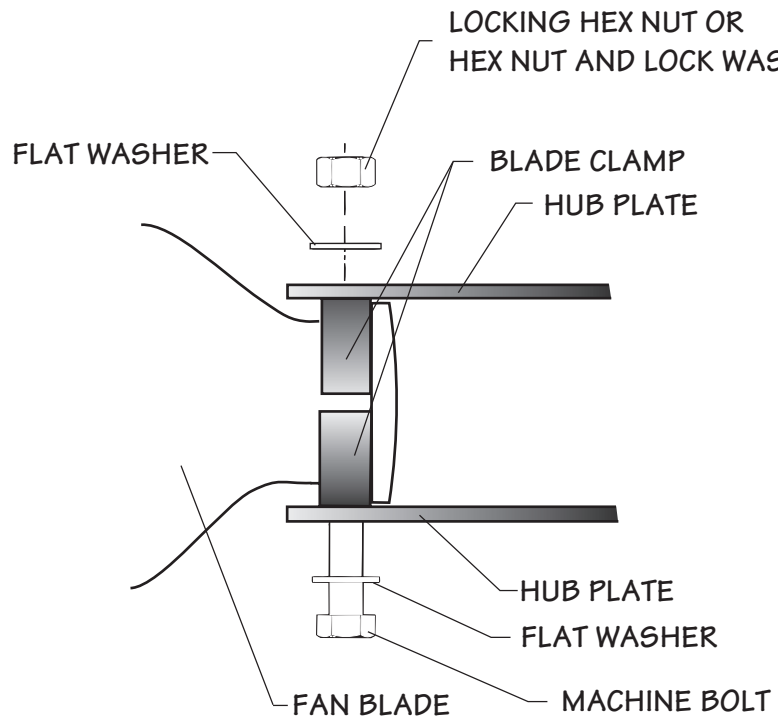

Figure 5

the concave blade side (TOP) on the discharge side between the hub assembly plates as shown in **Figure 4**. Vertically align the two bolt holes in the clamps and plates. Install two lubricated $\frac{3}{4}$ " bolts, four $\frac{3}{4}$ " flat washers, (two $\frac{3}{4}$ " lock washers if hardware material is monel), and two $\frac{3}{4}$ " hex nuts, engaging the nuts only three to four threads as shown in **Figure 5**. Do not tighten the hardware until all the blades have been installed. The blade must be free to rotate in the clamp for pitch adjustment.

4—Repeat until all blades, clamps, and hardware have been installed in the hub assembly.

Adjusting Fan Blade Pitch

Note

The trial pitch is the calculated setting for design conditions (water rate, heat load, air density, and brake horsepower). The trial pitch is provided by SPX Cooling Technologies (see page 2).

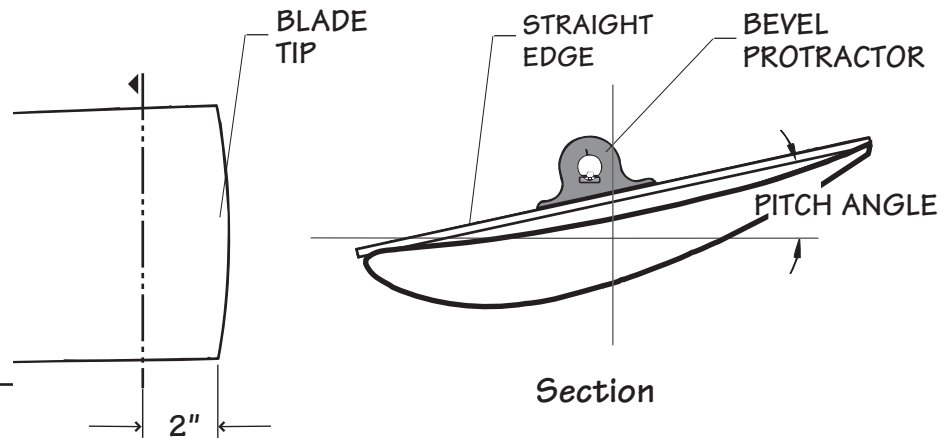

Figure 6

1—Select a position on the fan circumference and rotate each blade to this common location when setting or checking blade pitch. Support the blade tip to maintain a common rotation plane while setting the fan pitch. The pitch is set within 2" (51mm) of the blade tip by placing a bevel protractor on top of a parallel sided straight edge that extends across blade width as shown in **Figure 6**.

2—Pull the blade outward so the safety shoulder is in contact with the blade clamp, then set the pitch. See **Figure 5**. Blades should be within $\pm 1/4^\circ$ of the desired pitch angle. After the desired setting is obtained, progressively tighten the $3/4$ " hex nuts to 120 ft·lb_f (163 N·m) torque. Recheck the pitch angle. If required, loosen the hex nuts and reset the pitch as necessary until the proper pitch angle is obtained with the $3/4$ " hex nuts at 120 ft·lb_f (163 N·m) torque.

3—Repeat step 2 for all blades.

4—Check the vertical blade-tip track variation. The allowable vertical variation from a reference plane is ± 1 " (25mm). If a blade's tip track is out of tolerance, loosen the $3/4$ " hardware and change the blade tip support location higher or lower as required to adjust the tip track. Recheck blade pitch angle.

Hub Cover Installation

Install the hub cover as shown in **Figure 1** and **Figure 7**. Tighten all hex nuts to 15 ft·lb_f (20 N·m) torque.

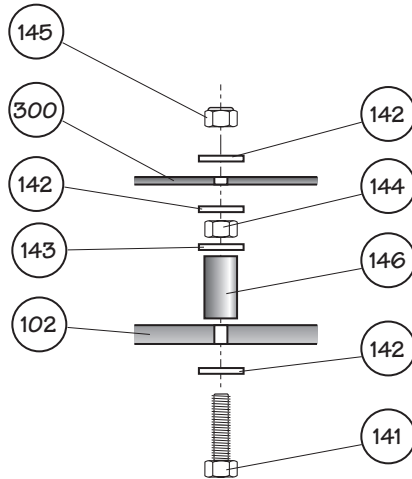

Figure 7

Fan Maintenance

Preventative maintenance will prolong useful life and assure continued trouble-free operation. After the first week and subsequently at six month intervals:

- Torque all hardware to specifications referenced in this manual.
- Visually inspect the fan for airborne debris damage, contact with fan cylinder segments, and corrosive attack. Correct any situations determined detrimental to fan operation.
- Remove any accumulated scale or dirt.
- Clear blade drain holes.

Service

Proper identification of your fan is necessary to insure you receive correct replacement parts. The Marley cooling tower serial number can be used to determine the fan and any components installed and maintained as original equipment on a Marley cooling tower. The fan diameter and moment weight class from the blade nameplate (see **Figure 3**) is required to identify blades for replacement. The fan hub



assembly identification number (see **Figure 1**) is required to identify a replacement hub assembly or repair components. Please provide the Marley sales representative the necessary information when ordering replacement fans or components.

Blades can be replaced without rebalancing the entire fan.

If rebalancing is desired, contact the Marley sales representative in your area.

Motor Load

The corrected horsepower should be close to but not exceed the contract horsepower specified. Determine corrected horsepower using the following equation.

$$HP_C = \frac{VOLTS_A \times AMPS_A \times DENSITY_A}{TY_D} \times HP_N$$

HP _C	=	Corrected Horsepower	DENSITY _A	=	Actual Air Density
VOLTS _A	=	Actual Volts	VOLTS _N	=	Nameplate Volts
AMPS _A	=	Actual Amperage	AMPS _N	=	Nameplate Amperage
			HP _N	=	Nameplate Horsepower

Actual volts and amperage must be obtained with the fan running and the specified rate of water flowing over the tower after the motor and Geareducer have reached operating temperature (approximately 30 minutes of operation).

Note

Measurements taken on motors operating with Variable Frequency Drive controls may read up to 15% high from errors in measuring the approximated sine wave. Instruments capable of measuring a squared off wave form accurately should be used for measuring power in this situation.

Do not exceed 30 sec/hour total motor starting time as motor may overheat.

SPX Cooling Technologies

Balcke | Hamon Dry Cooling | Marley

/ 7401 W 129 Street // Overland Park, KS USA 66213 // +1 913 664 7400 // spxcooling@ct.spx.com // www.spxcooling.com /

In the interest of technological progress, all products are subject to design and/or material change without notice
©2005 SPX Cooling Technologies, Inc. | Printed in USA