

INSTRUCTION MANUAL

SONAMP® 275 SE / 275X3 SE

STEREO POWER AMPLIFIER



IMPORTANT SAFETY INSTRUCTIONS

CAUTION: Read all of these instructions before you operate and save instructions for later use.

- 1. Read Instructions** — All these safety and operating instructions should be read before the amplifier is operated.
- 2. Retain Instructions** — These safety and operating instructions should be retained for future reference.
- 3. Heed Warnings** — All warnings on the amplifier and in the operating instructions should be adhered to.
- 4. Follow Instructions** — All operating and use instructions should be followed.
- 5. Water and Moisture** — The amplifier should not be used near water — for example, near a bathtub, washbowl, kitchen sink, laundry tub, in a wet basement, or near a swimming pool, and the like.
- 6. Carts and Stands** — The amplifier should be used only with a cart or stand that is recommended by the manufacturer.
 - An amplifier and cart combination should be moved with care. Quick stops, excessive force, and uneven surfaces may cause the amplifier and cart combination to overturn.
- 7. Caution:** To prevent electric shock, do not use the amplifier's polarized plug with an extension cord, receptacle, or other outlets unless the blades can be fully inserted to prevent blade exposure.
- 8. Ventilation** — The amplifier should be situated so that its location or position does not interfere with its proper ventilation. For example, the amplifier should not be situated on a bed, sofa, rug, or similar surface that may block the ventilation openings; or be placed in a built-in installation, such as a bookcase or cabinet, that may impede the flow of air through the ventilation openings.
- 9. Heat** — The amplifier should be situated away from heat sources such as radiators, heat registers, stoves, or other appliances (including other amplifiers) that produce heat.
- 10. Power Sources** — The amplifier should be connected to a power supply only of the type described in the operating instructions or as marked on the amplifier.
- 11. Grounding or Polarization** — Precautions should be taken so that the grounding or polarization means of the amplifier is not defeated.
- 12. Power-Cord Protection** — Power supply cords should be routed so that they are not likely to be walked on or pinched by items placed upon or against them, paying particular attention to cords at plugs, convenience receptacles, and the point where they exit from the amplifier.
- 13. Cleaning** — The amplifier should be cleaned only as recommended by the manufacturer.
- 14. Non-Use Periods** — The power cord of the amplifier should be unplugged from the outlet when left unused for a long period of time.
- 15. Object and Liquid Entry** — Care should be taken so that objects do not fall and liquids are not spilled into the enclosure through openings.
- 16. Damage Requiring Service** — The amplifier should be serviced by qualified service personnel when:
 - a. The power-supply cord or the plug has been damaged; or
 - b. Objects have fallen or liquid has been spilled into the amplifier; or
 - c. The amplifier has been exposed to rain; or
 - d. The amplifier does not appear to operate normally or exhibits a marked change in performance; or
 - e. The amplifier has been dropped or the enclosure damaged.

- 17. Servicing** — The user should not attempt to service the amplifier beyond that described in the operating instructions. All other servicing should be referred to qualified service personnel.



CAUTION: TO REDUCE THE RISK OF ELECTRIC SHOCK, DO NOT REMOVE COVER (OR BACK) NO USER SERVICEABLE PARTS INSIDE REFER SERVICING TO AUTHORIZED SERVICE PERSONNEL.

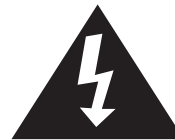

The lightning flash with arrowhead symbol, within an equilateral triangle, is intended to alert the user to the presence of uninsulated dangerous voltage within the product's enclosure that may be of sufficient magnitude to constitute a risk of electric shock to persons.



The exclamation point within an equilateral triangle is intended to alert the user to the presence of important operating and maintenance (servicing) instructions in the literature accompanying the appliance.

WARNING: TO PREVENT FIRE OR SHOCK HAZARD, DO NOT EXPOSE THIS APPLIANCE TO RAIN OR MOISTURE. THE APPLIANCE SHALL NOT BE EXPOSED TO DRIPPING OR SPLASHING. NO OBJECTS FILLED WITH LIQUIDS, SUCH AS VASES, SHALL BE PLACED ON THE APPLIANCE.



WARNING
MOVE WITH CARE

INSTRUCTION MANUAL

SONAMP® 275 SE / 275X3 SE

STEREO POWER AMPLIFIER



INTRODUCTION

Thank you for purchasing the Sonamp® 275 SE/275X3 SE. These amps incorporate Sonance's exclusive SAT™ (Smart Amp Technology) module that allows you to customize the amplifier to the installation by simply removing two screws on the back panel and inserting the desired module. The 275 SE/275X3 SE (Sound Enhancement) amplifiers include a factory-installed BBE® Sound Enhancement SAT module. The BBE process improves presence and detail of speakers, especially at lower listening volumes. This makes it particularly effective at improving the sound quality of distributed audio systems playing background music. BBE restores clarity and definition (or focus) to spoken voices, making paging systems easier to understand without having to run them at high volumes. The BBE process is so effective that it can even compensate for inferior sound from poor-quality source material or compressed sources like MP3, etc. In addition to manual control, the BBE effect can also be triggered on/off and the effect amount changed (+6dB or +9dB) by an external control voltage.

The 275 SE/275X3 SE also includes these important features:

- Recessed power switch that prevents accidental turn-off
- Tamper-resistant, recessed input level and auto-on sensitivity controls
- Auto-on dip switch for turn-on delay (2, 4, 6, 8, 12 seconds)
- Defeatable high-pass filter to protect in-wall volume controls
- Bridge/mono switch (not available on 275X3 SE)
- Ground lift switch
- High-current amplifier topology that can operate at 2.66 ohms
- Defeatable auto-on signal sensing
- Active current limit, short-circuit and speaker protection
- Signal preset LEDs
- Protect/Clipping LEDs for easy level setup
- Auto-resetting thermal protection shutoff
- Inrush current-limiting circuit

This manual applies to the 275 SE, 273X3 SE and their rack-mount versions. Except where noted, the installation, connection and use instructions are identical for all models.

BOX CONTENTS

Your Sonamp 275 SE/275X3 SE box should contain the following items:

- (1) Sonamp 275 SE or 275X3 SE amplifier
- (1) IEC Power cord (Note: A power cord is not included with 230V models)
- (1) Rack-mount hardware package (RMF versions only)
- (1) Speaker zone label sheet (275X3 SE only)

UNPACKING

Save the carton and the styrofoam inserts for future safe transport in case you move or the amplifier ever requires shipping for repair. Note, it is best if you place it into an additional outer "overcarton" before shipment to minimize a chance of theft in shipment.

Before you proceed, find the serial number which is located on the rear panel of the amplifier and note it here for future reference:

S/N _____

PLACING THE AMPLIFIER

- Keep the amplifier out of direct sunlight and away from windows that could let in rain.

- The amplifier should be placed away from heat sources such as hot air ducts or radiators.
- Do not place the amplifier directly on carpet that could interfere with airflow into its bottom vent openings.
- If you place your amplifier on the floor near your speakers, elevate it up off the carpet.
- If you stack your components, it is better to place the amplifier above or alongside your other components. When driven hard, the amplifier creates significant heat and can affect components stacked on top of it.
- If you place the amplifier inside a cabinet, allow ample ventilation and at least 2" clearance on top and both sides.
- Very sensitive low-level sources might pick up some hum radiated from the amplifier's power supply.

POWERING THE AMPLIFIER

AC Line Cord

The Sonamp 275 SE/275X3 SE feature a removable IEC power cord to allow for easy installation. Plug the female end of the power cord into the connector on the rear panel (Figure 1, #23) and plug the male end into a grounded wall socket. **DO NOT plug the power cord into an AC outlet on your preamplifier/receiver.**

CAUTION: TO PREVENT ELECTRIC SHOCK, DO NOT DEFEAT THE THIRD PRONG OF THE POWER CORD PLUG.

ATTENTION: AFIN D'EVITER TOUT RISQUE D'ELECTROCUTION, NEPAS ENLEVER LA 3EME FICHE DE LA PRISE ELECTRIQUE.

Use only a heavy-duty extension cord, if required, to avoid starving the amplifier of all the current necessary for full-power operation.

A.C. On LED (Figure 1, #3)

This LED indicates that the AC power line cord is plugged into a live AC outlet. If the main AC line fuse ever opens, this LED will go out. To use the Auto-On feature, this LED must remain on at all times. The Power switch has no effect on this LED.

AC Fuse (Figure 1, #22)

This will blow to protect the unit from possible internal parts failure. NEVER replace the fuse with any size other than that indicated on the rear panel to avoid more serious damage. Substitution of a larger fuse may create serious damage to internal parts and will void your Sonance warranty.

CAUTION: For continued protection against fire, replace the fuse with only the same type and rating.

Ground Lift Switch (Figure 1, #20)

The Sonamp 275 SE/275X3 SE feature a ground lift switch to eliminate hum caused by ground loops. This is often set up by the chassis making contact in a rack system. This eliminates the need to insulate the rack mount faceplates with nylon washers.

MAKING CONNECTIONS

Before making any signal or speaker connections, make sure the amplifier's power is turned OFF and its power cord is unplugged.

When making connections, make sure there is no strain or tension on input leads or speaker wires that could cause them to pull loose later on.

INSTRUCTION MANUAL

SONAMP® 275 SE / 275X3 SE STEREO POWER AMPLIFIER

Figure 1:
Front and
Rear Panels

275 SE FRONT

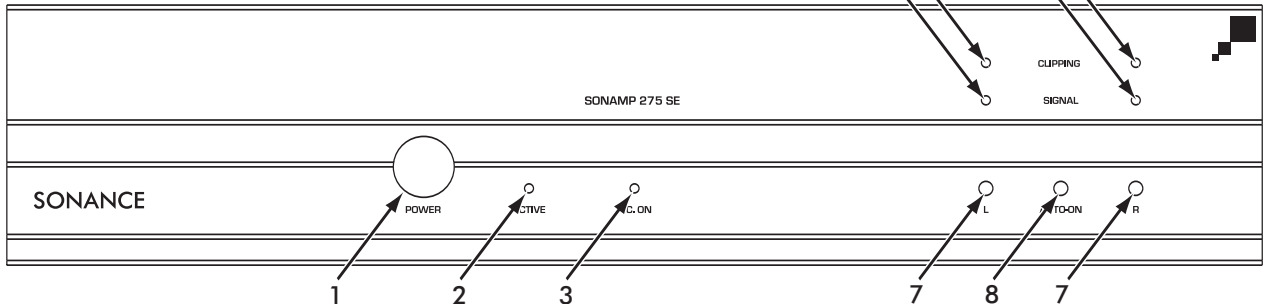

275 SE REAR

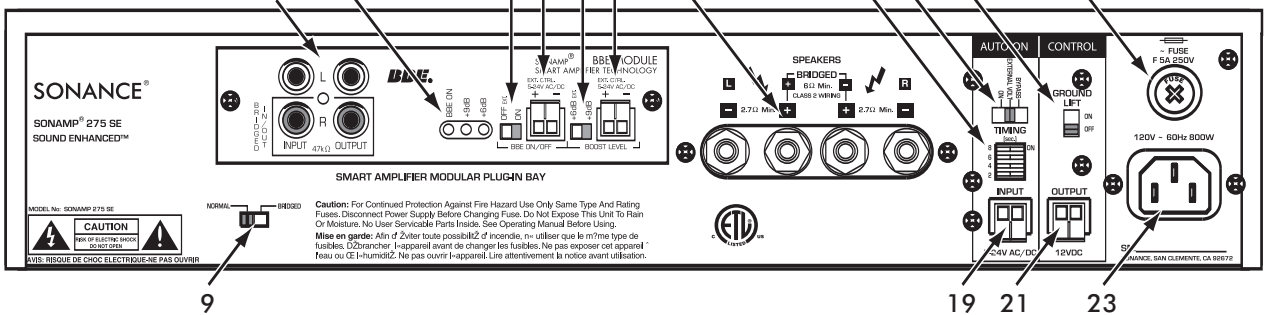

- | | | | |
|---------------------------------------|---|--|--|
| 1. POWER SWITCH | 8. AUTO-ON SENSITIVITY ADJUSTMENT | 14. BBE EFFECT LEVEL SWITCH | 19. AUTO-ON CONTROL VOLTAGE INPUT CONNECTION |
| 2. ACTIVE L.E.D. | 9. AMPLIFIER BRIDGE SWITCH (275 SE ONLY) | 15. BBE EFFECT LEVEL EXTERNAL CONTROL CONNECTION | 20. GROUND LIFT SWITCH |
| 3. AC ON L.E.D. | 10. RCA INPUT/OUTPUT JACKS (275 X3 SE ONLY) | 16. SPEAKER CONNECTORS | 21. CONTROL VOLTAGE OUTPUT CONNECTION |
| 4. SPEAKER SELECTORS (275 X3 SE ONLY) | 11. BBE STATUS LEDs | 17. AUTO-ON TIMING DELAY DIP SWITCHES | 22. FUSE |
| 5. SIGNAL L.E.D.s | 12. BBE ON/OFF SWITCH | 18. AUTO-ON SWITCH | 23. POWER CORD CONNECTION |
| 6. CLIPPING L.E.D.s | 13. BBE ON/OFF EXTERNAL CONTROL CONNECTION | | |

275X3 SE FRONT

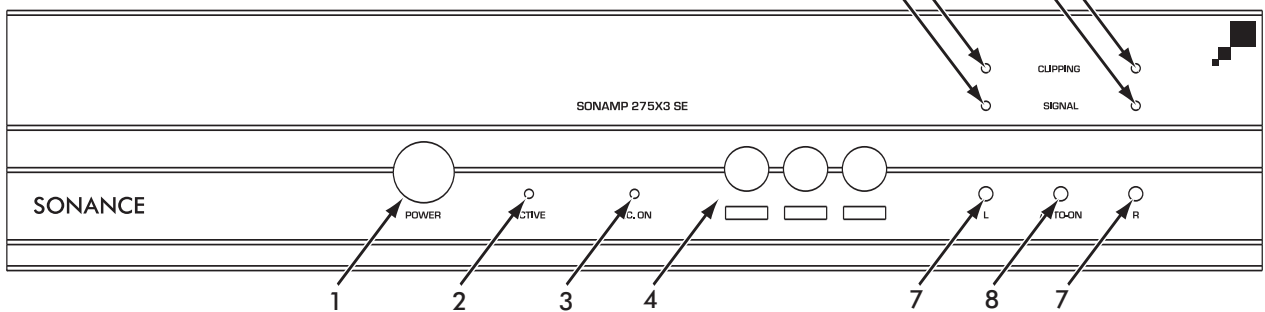

275X3 SE REAR

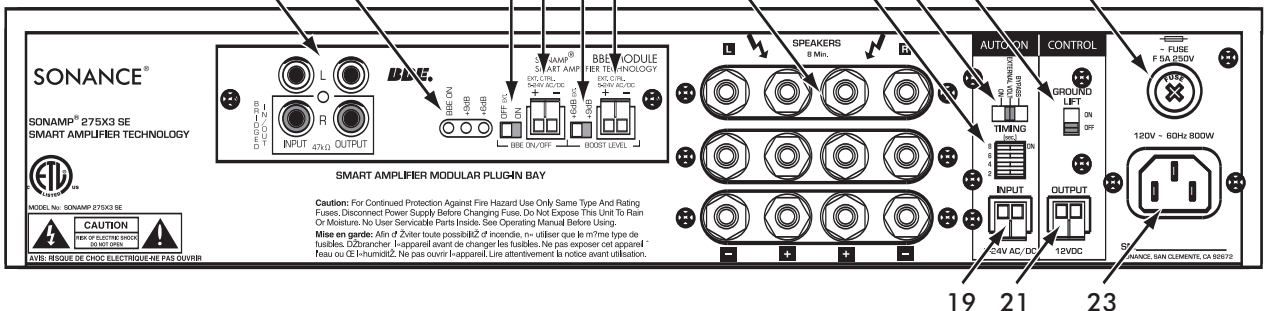

INSTRUCTION MANUAL

SONAMP® 275 SE / 275X3 SE

STEREO POWER AMPLIFIER

Input Connections (Figure 1, #10)

Input signal is connected via the R and L RCA Input jacks. Make sure these are consistent with the R and L outputs from your preamplifier or source device.

Output Connections (Figure 1, #10)

The BBE SAT module included with the 275 SE/ 275X3 SE includes buffered R and L RCA output jacks. These can link additional power amplifiers to a single source component without using messy Y-cord adaptors.

Note: The buffered output signal is not BBE-processed.

Speaker Connectors (Figure 1, #16)

The speaker connectors on the Sonamp 275 SE/275X3 SE are hex style “5-way” binding posts. They can accept wire terminated in spade lugs, pins, single and double banana connectors as well as bare wire.

Caution: Do not over-tighten when using a hex nut-driver or socket.

Making Speaker Connections: Stereo Operation (Figure 2)

All four connections are required for stereo operation — negative signal paths can NOT be combined. Minimum total impedance is 2.66 ohms (three pairs of 8-ohm speakers).

It is important to observe correct speaker polarity when using this amplifier in the stereo mode. One side of the speaker lead will have some sort of mark, either printing, a raised ridge on the insulation, or different color of conductor. This permits you to know which wire you had connected to the + and which to the – speaker terminal so you can do exactly the same at the power amplifier terminals. If polarity of one speaker is reversed, the speakers will be out of phase from each other, which will severely degrade sound quality. Sonance recommends that red = “R+”, black = “R-”, white = “L+” and green = “L-”. Most importantly, adopt a color protocol and stick with it.

Making Speaker Connections: Bridged Operation – 275 SE only (Figure 2)

The 275 SE can operate in single-channel bridged mode, which increases the amplifier’s power to 250 watts RMS (twice its 4-ohm stereo rating).

Note When operating the amplifier in the bridged mode be sure the speakers are rated to handle the increased output power.

For bridged operation, use only the two positive (red) speaker connectors and the right channel input connector. Make sure that the Amplifier Bridge Switch (Figure 1, #9) is set to the correct position.

IMPORTANT: Minimum impedance for bridged operation is 6 ohms.

Connecting Multiple Speakers

The 275 SE and 275X3 SE are both capable of handling a minimum total impedance of 2.66 ohms without strain or distortion. This means you can safely connect up to three pairs of high-quality 8-ohm speakers (we recommend Sonance speakers, of course!). You can connect the three sets of speakers to the same set of speaker connection posts on the 275 SE or connect one set to each of the three sets of speaker connection posts on the 275X3 SE.

Caution: If any of your speakers have a rated impedance of less than 8 ohms, be sure that the total speaker impedance is not less than 2.66 ohms per channel. If you are in doubt, consult your Sonance dealer, custom installer, or Sonance Technical Service. To calculate impedance, use the following equation:

$$\frac{1}{\left(\frac{1}{A}\right) + \left(\frac{1}{B}\right) + \left(\frac{1}{C}\right) + \left(\frac{1}{D}\right)}$$

Figure 2:
Proper
Speaker
Connections

NORMAL STEREO

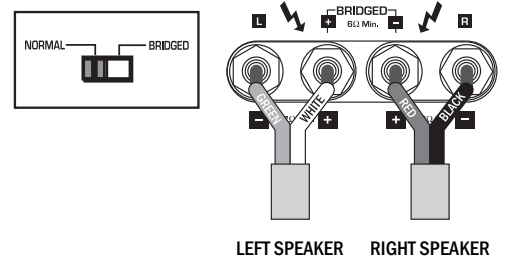

BRIDGED (275 SE ONLY)

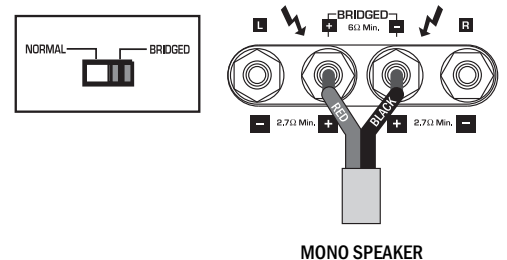

OPERATING THE 275 SE/275X3 SE

Operating Tip

The Sonamp 275 SE and 275X3 SE have an ingenious and very sophisticated auto turn on/off circuit. Please read these instructions completely so you do not get frustrated trying to operate them for the first time.

Power Switch (Figure 1, #1)

Press once to the “in” position to turn the amplifier on. Press again to the “out” position to turn the amp off. Leave the Power Switch in the “in” position when using either of the the Auto On Modes (see below).

Auto-On Modes

The Auto-On switch located on the rear panel (Figure 1, #18) selects between “On” (audio trigger mode), “External Volt” (control voltage activation mode), and “Bypass” (activated only by the Power Switch).

Audio Trigger Mode (Auto-On Switch “ON” Position)

When the Auto On switch is set to the ON (left-hand) position, any audio signal arriving at the amplifier’s input connectors will trigger the automatic turn-on circuitry to activate the amplifier for operation. The Active LED on the front panel (Figure 1, #2) illuminates when the amplifier is operational. The sensitivity of the Auto-On circuit can be increased or decreased by adjusting the level control on the front panel (Figure 1, #8).

The amplifier will remain on for approximately 3½ minutes after the audio signal has ceased. This provides ample time to prevent erratic operation from pauses between musical passages or while changing sources. The Audio Trigger feature frees you from having to place the amplifier in a rack with the other components. Here are a few installation possibilities:

- Local-room system coupled with a multi-CD changer.
- Surround sound rear or side channels.
- Multi-room, multi-source control systems.
- Use the Audio Trigger Mode with the delay settings to control a 16-zone system with 4 amplifiers. (See Figure 11, on page 10.)
- Or even an amplifier-controlled lava lamp! (See Figure 12, on page 11).

INSTRUCTION MANUAL

SONAMP® 275 SE / 275X3 SE

STEREO POWER AMPLIFIER



External Voltage Mode (Auto-On Switch "External Volt" Position)

The 275 SE/275X3 SE also feature a removable voltage input connector to connect other electronics with voltage control outputs. When the Auto-On switch is set to the "Voltage Trigger" (center) position, the voltage trigger monitors the voltage input connector (Figure 1, #19) and turns the amplifier ON when a voltage (either AC or DC) between 5V and 24V is detected.

Bypass Mode (Auto-On Switch "Bypass" position)

When the auto On switch is set to the BYPASS (right-hand) position, the Auto-On circuit is bypassed. In this mode, the amplifier is active any time the front-panel Power switch is in the "in" position.

Auto-On Delay Time Switches (Figure 1, #17)

The Auto-On Delay Time Switches allow you to set Auto-On turn-on delay times ranging from less than 1 second up to 12 seconds (see the table to the right as well as Figure 3 and Figure 11). When more than one Sonamp is being used, the Delay Time settings can be staggered to allow the amps to turn on at different times. This avoids taxing AC power lines beyond the capability of the circuit breaker(s).

DELAY SWITCHES				
2	4	6	8	X = ON O = OFF
X	X	X	X	< 1 SECOND DELAY
X	X	O	O	= 1 SECOND DELAY
X	O	O	O	= 2 SECOND DELAY
O	X	X	O	= 3 SECOND DELAY
O	X	O	O	= 4 SECOND DELAY
O	O	X	X	= 5 SECOND DELAY
O	O	X	O	= 6 SECOND DELAY
O	O	O	X	= 8 SECOND DELAY
O	O	O	O	= 12 SECOND DELAY

Voltage Output

Connector (Figure 1, #21)

The 275 SE and 275X3 SE feature a removable Voltage Output connector that provides 12V DC to control other devices such as Sonance A/V Automation Products, 12V relays, or other Sonamps (See Figure 4). The current draw on the connection should not exceed 200mA.

Active LED (Figure 1, #2)

This LED shows the amplifier's operational activity. The first time AC power is applied to the amplifier the Active LED will illuminate for about 1.75 minutes and then extinguish. This is a normal reaction of the Auto-On circuitry the very first time it receives power.

Thereafter, the 275 SE/275X3 SE are ready for automatic operation. In the Auto-On mode, the Active LED illuminates at the presence of an audio signal to the input jacks. When the Auto-On feature is defeated the Active LED functions as a normal on/off power indicator.

Note: Whenever AC power to the 275 SE/275X3 SE has been interrupted, the Active LED will illuminate for about 1.75 minutes when the power is first restored.

AC On LED (Figure 1, #3)

This LED indicates that the AC power cord is plugged-into a live AC outlet. If the amplifier's main AC fuse ever opens, this LED will extinguish. This LED must remain ON at all times for the amplifier's Auto-On features to operate. The amplifier's Power switch (Figure 1, #1) has no effect on the AC On LED.

Speaker Switch – 275X3 SE only (Figure 1, #4)

The Sonamp 275X3 SE has three pairs of speaker outputs. Each pair may be selected individually by one of the three front-panel push-button switches. The low impedance capability of the 275X3 SE allows connection of up to 3 pairs of 8-ohm speakers directly to the amplifier's output stage. The amplifier does not depend on an acoustically-inferior series connection for safe

operation. This eliminates any interactions between speaker systems, in-wall volume controls, etc.

Input Level Controls (Figure 1, #7)

The front-panel Input Level controls are recessed for adjustment by screw-driver only. This prevents accidental tampering with levels. The Level controls are factory-set to a nominal level safe for connecting a CD player output directly to the amplifier's line inputs. This would be the case in a receiver *Tape Out*/multiple autoformer-type volume control installation (Plug and Play).

For systems that incorporate in-wall volume controls: Use the Input Level controls to achieve the maximum desired listening level. Use the amplifier's *Overload* LEDs (Figure 1, #6) to assist when adjusting levels to the desired maximum. Set the input level controls to just below the LED's flash point. This practice helps to prevent autoformer saturation, distortion, or burnout of the in-wall volume control while also improving audio resolution.

For systems that do not incorporate in-wall volume controls: Use the Input Level controls to limit maximum safe gain to protect speakers or to optimize the signal-to-noise ratios between the source components and amplifier. Many output level controls on source components are overly-sensitive near their minimum position; by reducing the amplifier's Input Level control settings, you "compel" the source component's volume control to operate in its more uniform adjustment range. You can also use the amplifier's Input Level controls to adjust left/right channel balance for off-center listening positions.

Auto-On Sensitivity Adjustment (Figure 1, #8)

This control is conveniently placed on the front panel between the left and right Input Level controls. It is pre-set at its mid rotation setting, which works for most applications. If the source equipment's output level is low, rotate the Auto-On Sensitivity control *clockwise* so the Auto-On circuitry will respond at the lower level. If the source equipment's output has some low residual noise, rotating the Auto-On Sensitivity control *counterclockwise* will raise the Auto-On trigger level above the noise level, so it responds only to the signal level.

Clipping LEDs (Figure 1, #6) and Protection Circuits

The 275 SE/275X3 SE have independent L and R Clipping LEDs that alert you when the amplifier's normal operation has been exceeded. If the Clipping LEDs are constantly illuminated, a short circuit is most likely present. The speaker relay will disconnect when a DC offset condition is detected, thus preventing damaged voice coils.

The 275 SE/275X3 SE employ active-limiting protection circuits. When an over-current condition is realized, the amplifier will actively limit the amount of power delivered to the speaker connectors. No longer will annoying relay clicking get in the way of listening to an audio program.

Note: It is always a good idea to turn off the power switch while you are trouble-shooting for shorted connections or faults with source components.

INSTRUCTION MANUAL

SONAMP® 275 SE / 275X3 SE

STEREO POWER AMPLIFIER

BBE® CONNECTIONS AND OPERATION

Figure 3: BBE SAT Module Controls and Indicators

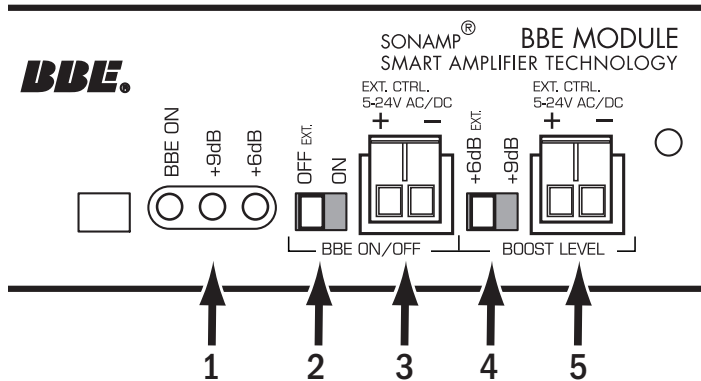

- Status LEDs:** Illuminate to show if the BBE process is ON, and how much processing (+6dB or +9dB) is being applied.
- BBE ON/OFF switch:** In the *OFF EXT.* position, BBE processing is bypassed; in the *ON* position BBE processing is applied.
 - When this switch is in the *OFF EXT.* position BBE processing can be automatically activated when an external control voltage is applied to the *BBE ON/OFF EXT. CTRL.* connector.
- BBE ON/OFF EXT. CTRL. connector:** When a control voltage appears at this connection and the *BBE ON/OFF* switch is in the *OFF EXT.* position, BBE processing is automatically activated.
 - The connection accepts AC or DC control voltages between 5V and 24V.
- BOOST LEVEL +6dB EXT./+9dB switch:** Sets the amount of BBE processing being applied to either +6dB or +9dB.
 - When this switch is in the +6dB *EXT.* position the amount of BBE processing being applied can be automatically changed to +9dB when an external control voltage is applied to the *BOOST LEVEL EXT. CTRL.* connector.
- BOOST LEVEL EXT. CTRL. connector:** When a control voltage appears at this connection, and the *BOOST LEVEL* switch is in the +6dB *EXT.* position, the amount of BBE processing being applied is automatically changed to +9dB.
 - The connection accepts AC or DC control voltages between 5V and 24V.

High-Pass Filter Settings (Figure 4)

The 275 SE and 275X3 SE have high-pass filters located on the BBE SAT Module circuit board. The filter settings are determined by the positions of a pair of shorting sleeves on jumper pins.

IMPORTANT: The high-pass filter jumpers are set at the factory in the high-pass filter ON position. Sonance HIGHLY RECOMMENDS that these jumpers remain in the ON position if the amplifier will be used in a system that includes in-wall volume controls for the speakers. The amplifier's high-pass filters reduce infrasonic energy and help protect autoformer-based volume controls from saturation and overload.

To bypass the high-pass filters, set the jumpers to the OFF position:

- The jumper pins are located in the marked area of the BBE SAT module circuit board, as shown in the upper portion of Figure 4.
- As shown in the lower portion of Figure 4, remove the shorting sleeves from their factory-set (ON) position on the jumper pins and replace them in the OFF positions. Make sure you insert the shorting sleeves all the way onto the jumper pins.

Figure 4: BBE SAT Module High-Pass Filter Jumpers

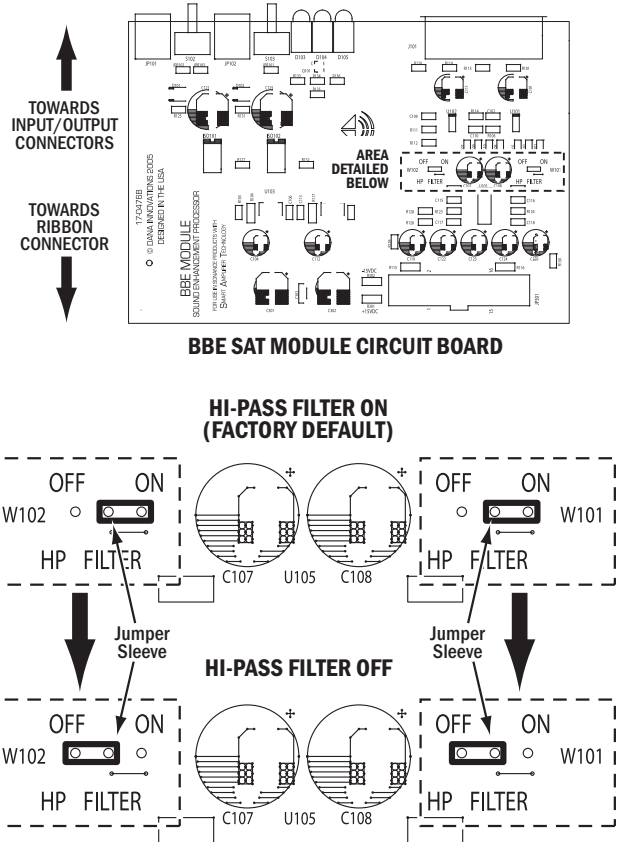

BBE SAT Module Connections

Systems With No External Control Capability (Figure 5)

- Connect the BBE module's *Input* jacks to the stereo line-level source.
 - If you're operating the 275 SE in the bridged mode, use the *R* input only.
- Connect the amplifier's speaker outputs to the speakers.
- If you wish to feed the source's signal to additional amplifiers, connect them to the BBE module's *Output* jacks.

Note: The signal sent through the module's *Output* jacks is not BBE processed.

Systems With External Control Capability (Figure 6)

The BBE sound enhancement process can be activated and the amount of BBE processing changed by an external control voltage. This allows an audio system with two different sources to employ BBE processing for only one source, or to employ different amounts of BBE processing for the different sources.

Figure 6 shows a system with two sources (such as would be used in a doctor's office): a CD player playing uncompressed audio that doesn't require BBE processing, and an iPort™ with an iPod® playing compressed audio files that could benefit from BBE enhancement. Both sources are connected to a Sonance AL1 Line-Level Switcher that automatically switches to the iPod connections whenever it senses an audio signal from the iPod. Whenever AL1 selects the iPod input it also sends a +12V control voltage to the BBE module's *BBE ON/OFF EXT. CTRL.* connector, which activates the BBE processing.

INSTRUCTION MANUAL

SONAMP® 275 SE / 275X3 SE

STEREO POWER AMPLIFIER



Figure 5: BBE Module Connections in a System with No External Control Capability

Line-Level Stereo Source Component
(CD player, satellite radio tuner, etc.)

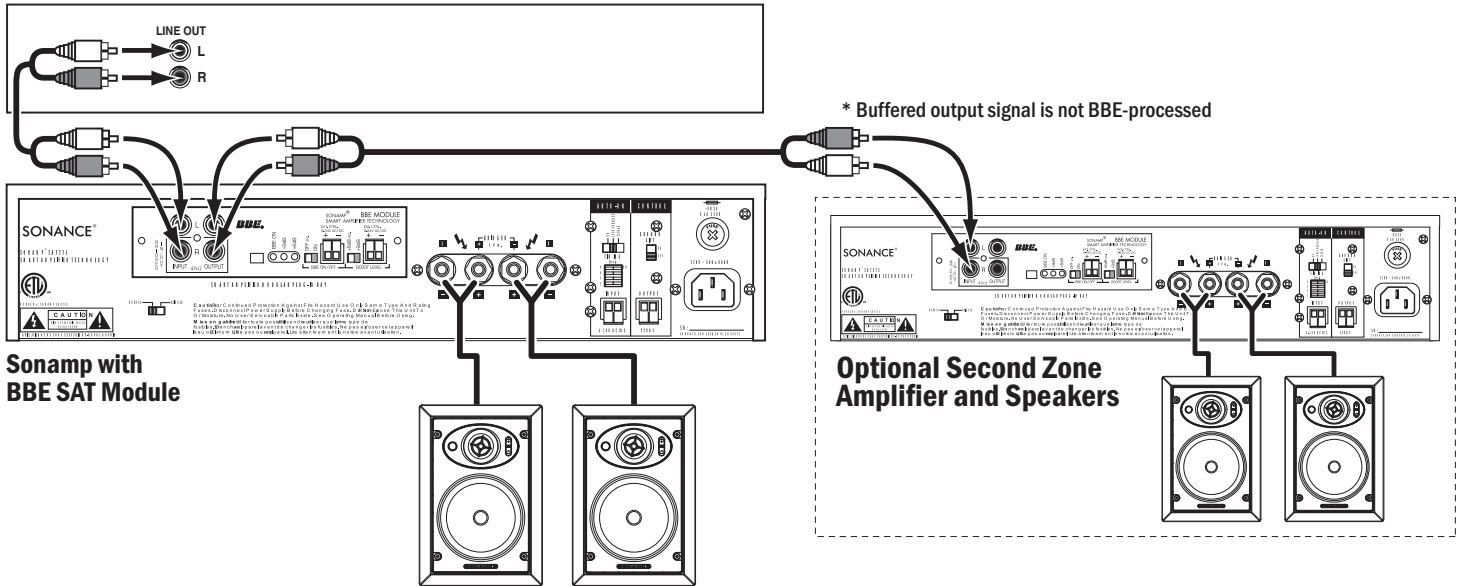
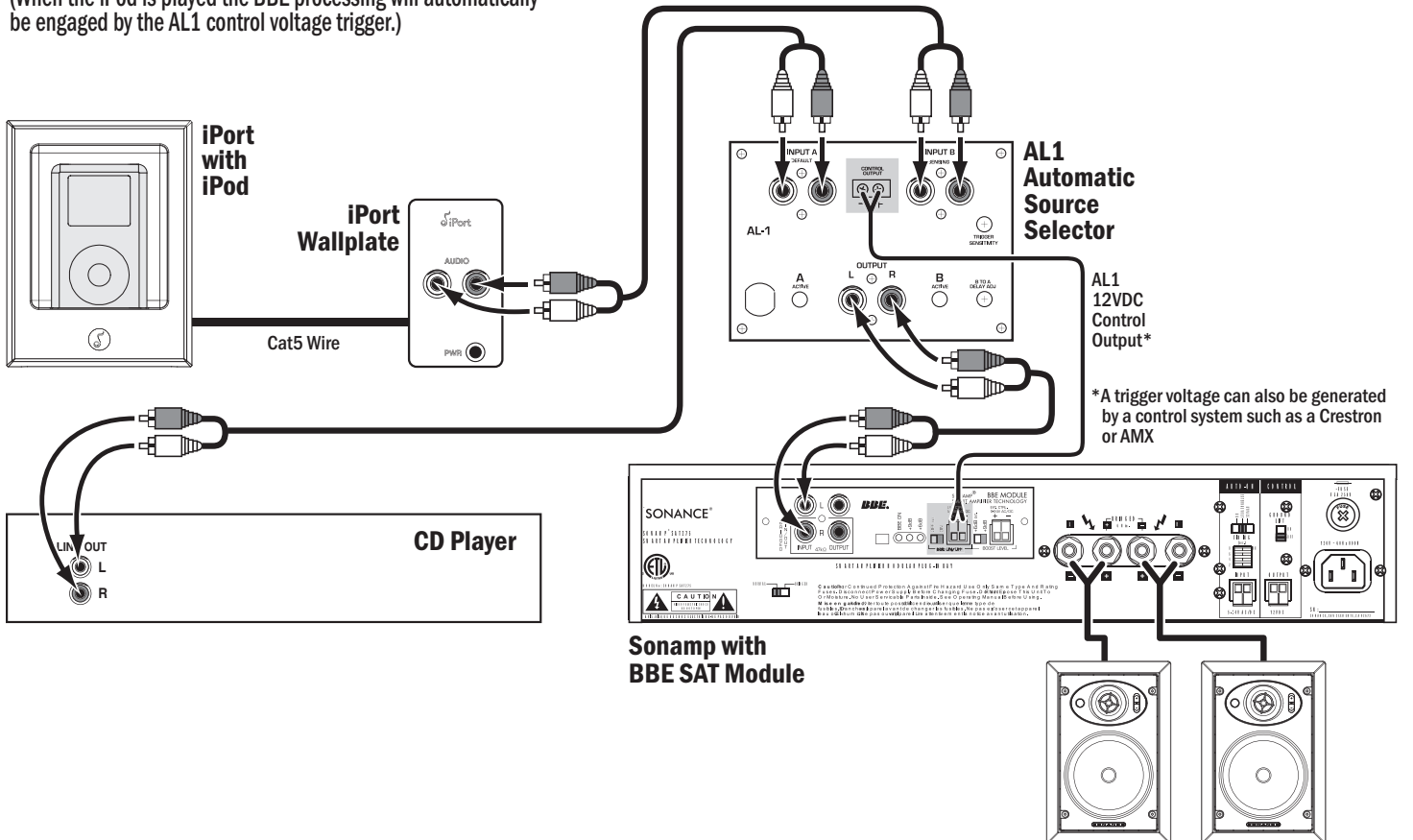

Figure 6: BBE Module Connections in a System with External Control Capability

(When the iPod is played the BBE processing will automatically be engaged by the AL1 control voltage trigger.)



INSTRUCTION MANUAL

SONAMP® 275 SE / 275X3 SE

STEREO POWER AMPLIFIER



When the AL1 no longer detects an audio signal from the iPod it automatically switches to the CD player input and removes the +12V control voltage. When the control voltage is removed the BBE module switches the BBE processing off.

The BBE module has a second control voltage input (the *BOOST LEVEL EXT. CTRL.* connector) that operates in the same way, but changes the amount of BBE processing from +6dB to +9dB. This connector can be employed when different amounts of BBE processing are desired for two different sources.

Note: The BBE module's External Control inputs can also be triggered by voltage from a Crestron or similar control system.

1. Connect the BBE module's *Input* jacks to the AL1 switcher's *Outputs*.
 - If you're operating the Sonamp in the bridged mode, use the *R* input only.
2. Connect the outputs of the two sources to the AL1's *A* and *B* inputs.
 - Connect the source that you want BBE processed to the *B* inputs.
3. Connect the AL1's *Control Output* to the BBE module's *BBE ON/OFF EXT. CTRL.* input.
 - Make sure that the module's *BBE ON/OFF* switch is in the *OFF EXT.* position.
4. Connect the Sonamp's speaker outputs to the speakers.
5. If you wish to feed the AL1's signal to additional amplifiers, connect them to the BBE module's *Output* jacks. (The signal through the jacks is not BBE processed).
 - If the additional amplifiers are equipped with BBE module, run parallel control voltage connections to the other BBE modules.

REPLACING THE BBE SAT MODULE (Figure 7)

The 275 SE/275X3 SE Smart Amplifier Technology module bay allows future upgradability, greatly increasing the life span of the amplifier and making it compatible with new protocols. A new module can be easily swapped for the included BBE SAT module. Refer to the following steps and Figure 7 for SAT Module removal and installation.

IMPORTANT: Make sure the amplifier's Power switch is Off and its power cord is disconnected before removing the SAT module.

Figure 7: SAT Module Removal and Installation

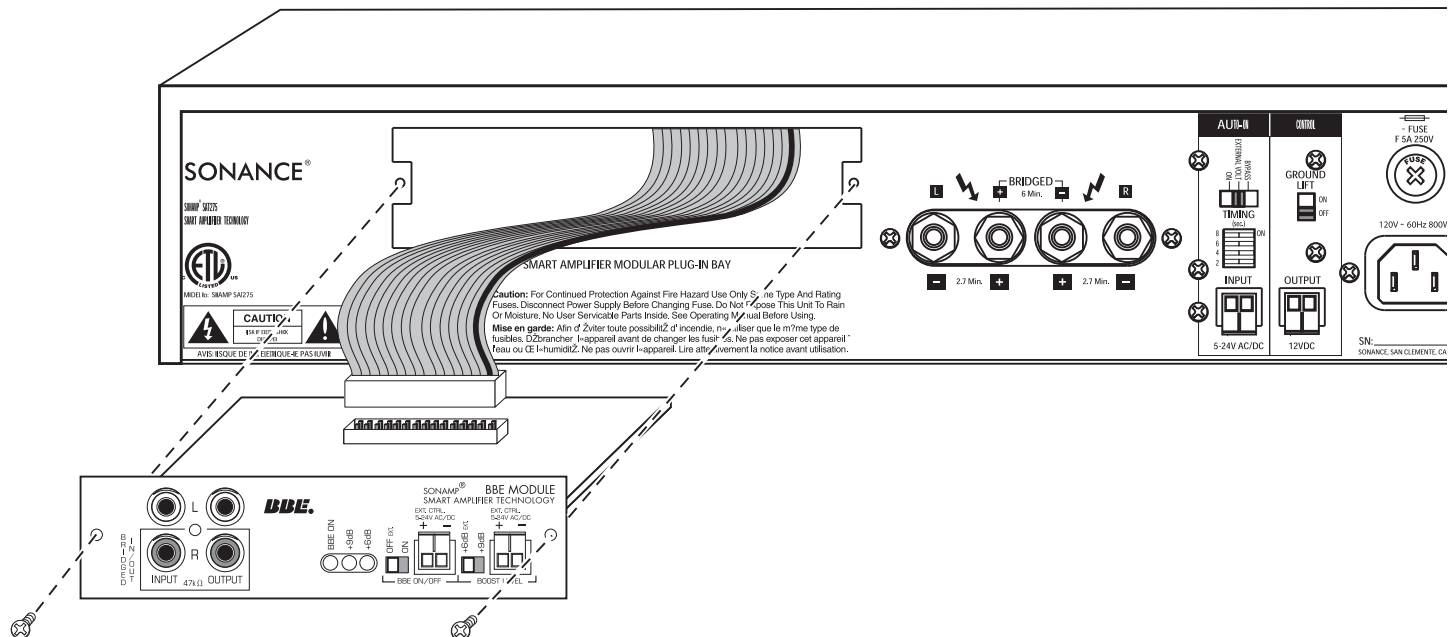

1. Unscrew and save the two screws holding the BBE SAT module in place.
2. Gently pull the module out of the SAT module bay.
3. Flip the tabs on the ends of the ribbon connector socket outward to release it and disconnect the cable. (Note the alignment of the connector.)
4. Select the desired position of any jumpers on the new SAT module (i.e. high pass filter).
5. Re-connect the ribbon cable to the ribbon cable connector on the new SAT module so that it clicks into place. Make sure the connector is aligned properly.
6. Slide the SAT module into the SAT module bay.
7. Replace the two mounting screws.

The following paragraphs explain how each SAT module can be used with the Sonamp 275 SE/275X3 SE. Currently available SAT modules are the LR1 and AL1 (sold separately). The BBE SAT module is also available separately, for use with other Sonamp models that have SAT module bays. Contact your Sonance-Authorized installer or dealer for more information on these or other SAT module options.

Figure 8: LR1 SAT Module

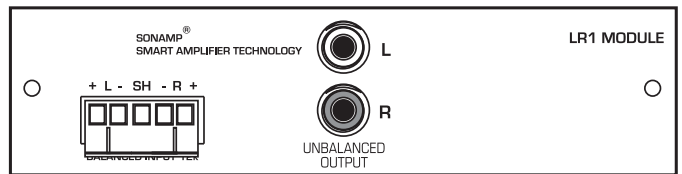

LR1 Module (Figure 8)

The LR1 — Balanced Line Receiver — module features a circuit that cancels out noise on long audio runs, (typically greater than thirty feet). This module has an input impedance of 12k ohms and is perfectly matched with the Sonance LS1 Balanced Line Sender (sold separately). This increases installation options, allowing the amplifier to be placed some distance from the rest of the audio system. The LR1 Module provides unbalanced (unity gain) stereo output jacks to feed signal to other amplifiers or other system components.

INSTRUCTION MANUAL

SONAMP® 275 SE / 275X3 SE

STEREO POWER AMPLIFIER



Figure 9: AL1 SAT Module

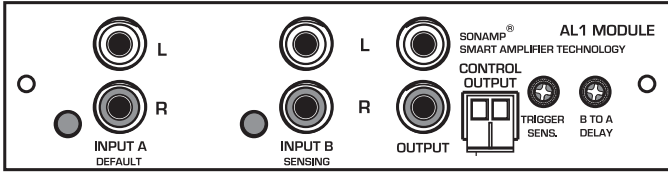

AL1 Module (Figures 9 & 10)

The AL1 — Automatic Line-Level Switcher — module has a default input as well as a sensing input. When signal is detected at the sensing input, that signal is fed to the amplifier as well as its output jacks. At the same time a 12V DC control signal is present on the removable screw connector.

The sensing input has a sensitivity control as well as a delay adjustment which controls the time the module waits after the signal at the sensing jack subsides before switching back to the default input.

Figure 10 shows a 275 SE amplifier with the AL1 module in a restaurant installation. The module's default input is connected to the house restaurant audio and the sensing input monitors the paging microphone. The output is feeding a second 275 SE that has the factory-installed BBE module.

Figure 10: Restaurant/Bar System Using One Sonamp 275 SE with an AL1 Module and Another 275 SE with the BBE Module

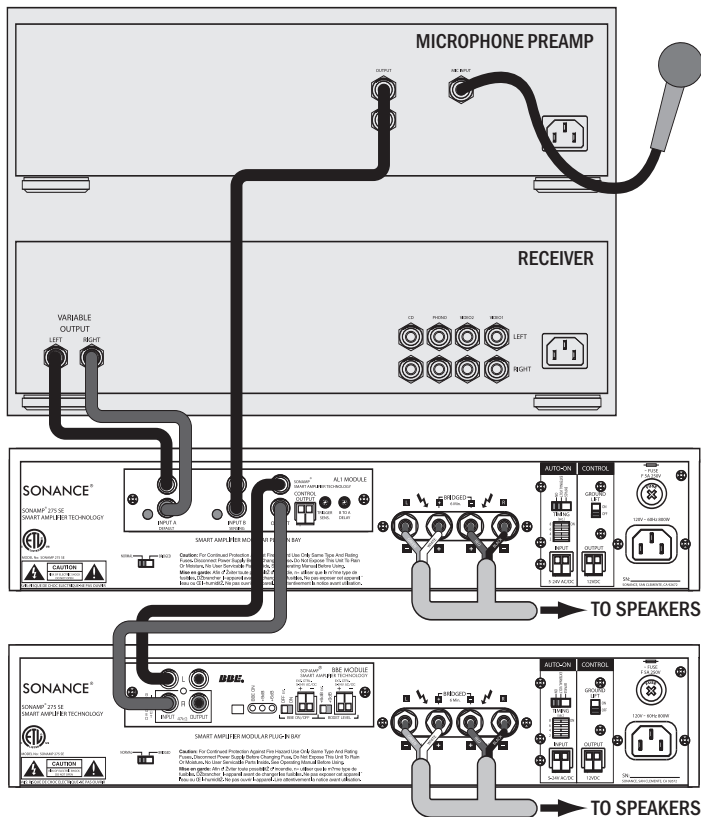

SPECIFICATIONS

Rated Power (20Hz – 20kHz) RMS:	75 Watts per channel @ 8 ohms 125 Watts per channel @ 4 ohms 135 Watts per channel @ 2.7 ohms
Bridged Power (20Hz – 20kHz) RMS:	250 Watts @ 8 ohms (275 SE only)
Midband Power (1kHz, at Clipping) RMS:	114 Watts per channel @ 8 ohms 140 Watts per channel @ 4 ohms 168 Watts per channel @ 2.7 ohms
Bridged Midband Power (1kHz) RMS:	270 Watts @ 8 ohms (275 SE only)
IHF Dynamic Power (20ms 1kHz Tone Burst) per IHF RS-490/3.2:	120 Watts per channel @ 8 ohms 194 Watts per channel @ 4 ohms 239 Watts per channel @ 2.7 ohms
IHF Dynamic Headroom	+1.75 dB @ 8 ohms +1.9 dB @ 4 ohms +2.5 dB @ 2.7 ohms
Total Harmonic Distortion (2-channel mode):	0.05% 20Hz – 20kHz @ 8 ohms 0.08% 20Hz – 20kHz @ 4 ohms 0.15% 20Hz – 20kHz @ 2.7 ohms
Total Harmonic Distortion (Bridged mode):	0.05% 20Hz – 20kHz @ 8 ohms
I.M. Distortion (SMPTE 4:1) @ 8 ohms:	0.008% @ 1 watt 0.015% @ 75 watts
Signal to Noise Ratio:	105dB below rated output (A-weighted)
Input Sensitivity:	0.7 volts for rated output (75 watts @ 8 ohms)
Input Impedance:	47k ohms, Min.
Power Requirement (120V version):	120 VAC, 50/60Hz
Power Requirement (230V version):	230 VAC, 50/60Hz
Power Consumption (all versions):	500 watts (625VA)
Heat Output	
(BTU/HR @ 8 ohms):	164 (classical); 232 (rock)
(BTU/HR @ 4 ohms):	294 (classical); 418 (rock)
(BTU/HR @ 2.7 ohms):	382 (classical); 542 (rock)
Dimensions (W x H x D):	16¾" x 3⅞" x 15¼" (425mm x 98mm x 387mm)
Dimensions w/Rack Ears (W x H x D):	19" x 3½" x 15¼" (483mm x 89mm x 387mm)
Rack Space Requirement:	2U
Shipping Weight:	24 lbs (10.9 kg)



INSTRUCTION MANUAL

SONAMP® 275 SE / 275X3 SE

STEREO POWER AMPLIFIER

Figure 11:
Four 275 SE Amplifiers
Powering Sixteen Zones
(Using Staggered Turn-On)

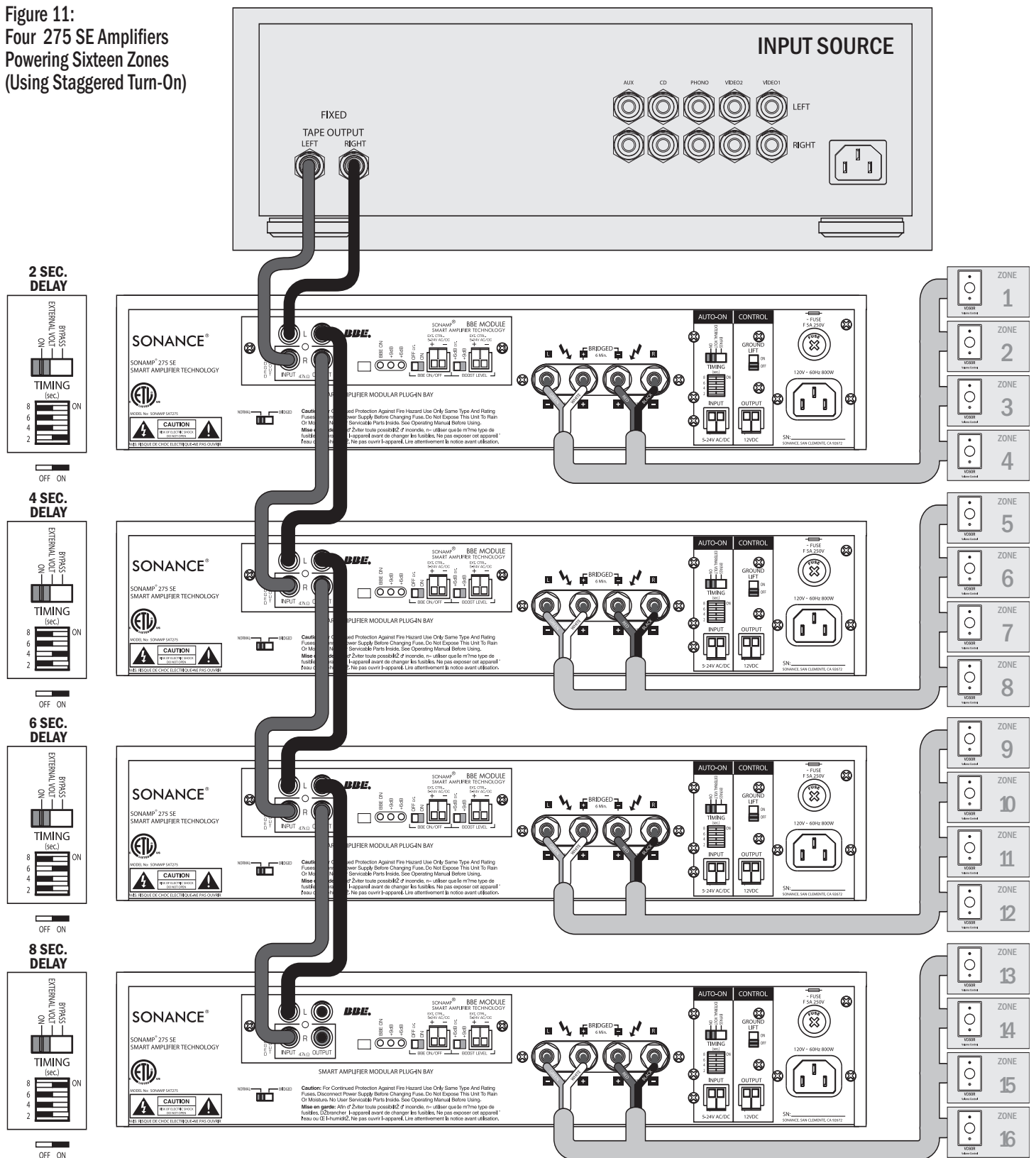

INSTRUCTION MANUAL

SONAMP® 275 SE / 275X3 SE

STEREO POWER AMPLIFIER



Figure 12: Sonamp 275 SE Providing an Output Voltage to Control a Lava Lamp

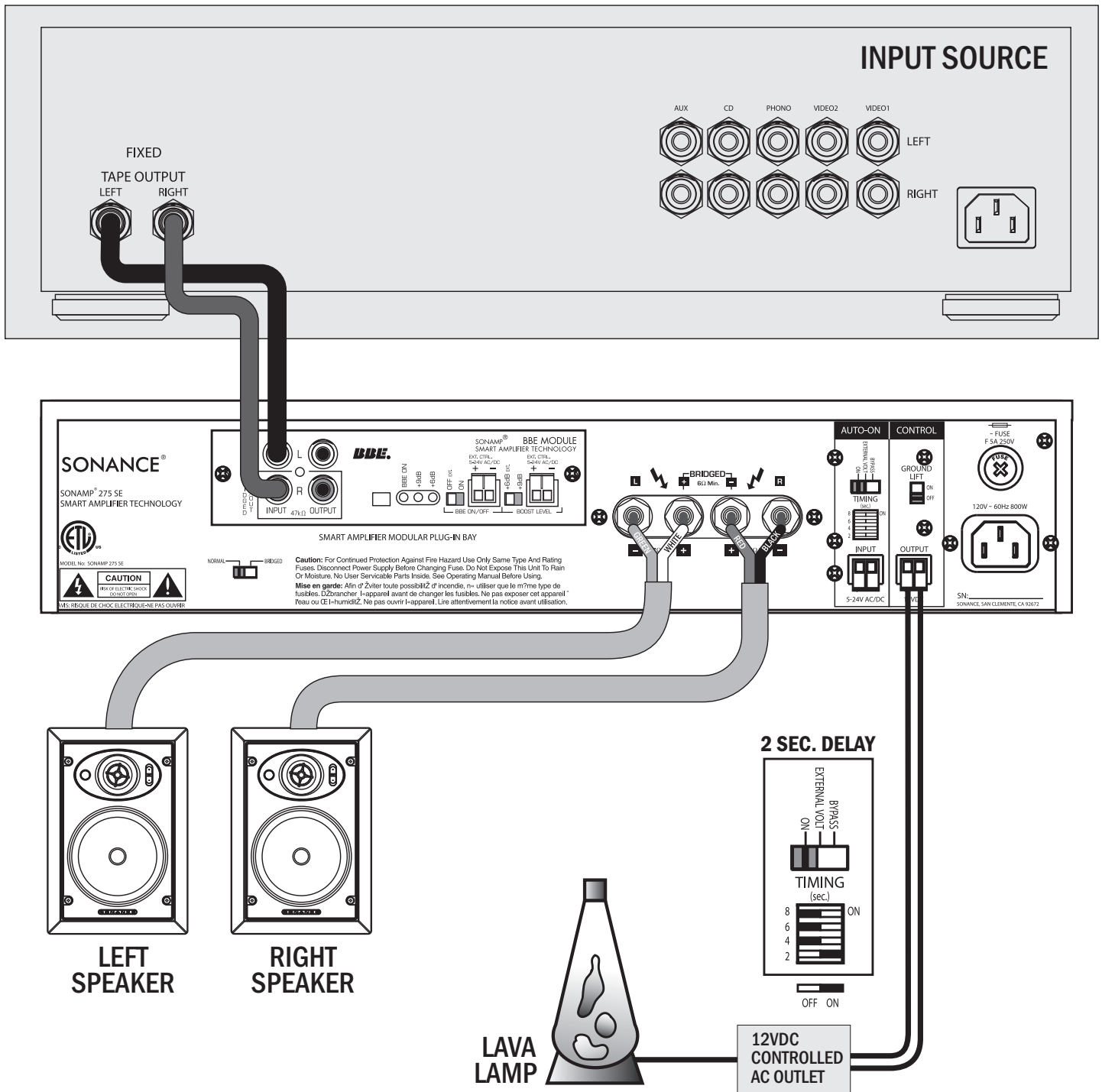

LIMITED FIVE (5) YEAR WARRANTY

Sonance warrants to the first end-user purchaser that this Sonance-brand product (“Product”), when purchased from an authorized Sonance Dealer/Distributor, will be free from defective workmanship and materials for the period stated below. Sonance will at its option and expense during the warranty period, either repair the defect or replace the Product with a new or remanufactured Product or a reasonable equivalent.

EXCLUSIONS

TO THE EXTENT PERMITTED BY LAW, THE WARRANTY SET FORTH ABOVE IS IN LIEU OF, AND EXCLUSIVE OF, ALL OTHER WARRANTIES, EXPRESS OR IMPLIED, AND IS THE SOLE AND EXCLUSIVE WARRANTY PROVIDED BY SONANCE. ALL OTHER EXPRESS AND IMPLIED WARRANTIES, INCLUDING THE IMPLIED WARRANTIES OF MERCHANTABILITY, IMPLIED WARRANTY OF FITNESS FOR USE, AND IMPLIED WARRANTY OF FITNESS FOR A PARTICULAR PURPOSE ARE SPECIFICALLY EXCLUDED. No one is authorized to make or modify any warranties on behalf of Sonance.

The warranty stated above is the sole and exclusive remedy and Sonance’s performance shall constitute full and final satisfaction of all obligations, liabilities and claims with respect to the Product. IN ANY EVENT, SONANCE SHALL NOT BE LIABLE FOR CONSEQUENTIAL, INCIDENTAL, ECONOMIC, PROPERTY, BODILY INJURY, OR PERSONAL INJURY DAMAGES ARISING FROM THE PRODUCT, ANY BREACH OF THIS WARRANTY OR OTHERWISE.

This warranty statement gives you specific legal rights, and you may have other rights which vary from state to state. Some states do not allow the exclusion of implied warranties or limitations of remedies, so the above exclusions and limitations may not apply. If your state does not allow disclaimer of implied warranties, the duration of such implied warranties is limited to period of Sonance’s express warranty.

Your Product Model and Description: 275 SE; 275X3 SE

Warranty Period for this Product: Five (5) years from the date on the original sales receipt or invoice or other satisfactory proof of purchase.

Additional Limitations and Exclusions from Warranty Coverage: The warranty described above is non-transferable, applies only to the initial installation of the Product, does not include installation of any repaired or replaced Product, does not include damage to allied or associated equipment which may result for any reason from use with this Product, and does not include labor or parts caused by accident, disaster, negligence, improper installation, misuse (e.g. overdriving the amplifier or speaker, excessive heat or cold or humidity, outdoor installation), or from service or repair which has not been authorized by Sonance.

Obtaining Authorized Service: To qualify for the warranty, you must contact your authorized Sonance Dealer/Installer or call Sonance Customer Service at (800) 582-0772 within the warranty period, must obtain a return merchandise number (RMA), and must deliver the Product to Sonance shipping prepaid during the warranty period, together with the original sales receipt, or invoice or other satisfactory proof of purchase.



©2008 Sonance. All rights reserved.

Sonance, Sonamp, Smart Amplifier Technology and iPort are trademarks or registered trademarks of Dana Innovations, Inc. “BBE” and its designs are the registered trademarks of BBE Sound, Inc. iPod is a registered trademark of Apple Inc.

Sonance • 212 Avenida Fabricante • San Clemente, CA 92672-7531, USA • (800) 582-7777 or (949) 492-7777 • FAX: (949) 361-5151 • Technical Support: (800) 582-0772

w w w . s o n a n c e . c o m