

SHARP SERVICE MANUAL

No. S4419CDES9///

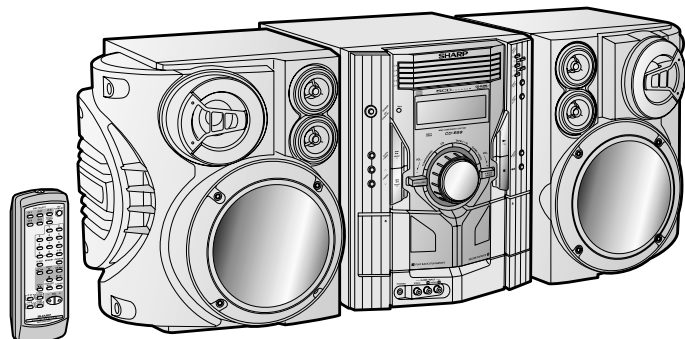

MINI COMPONENT SYSTEM

MODEL CD-ES9

CD-ES9 Mini Component System consisting of CD-ES9 (main unit) and CP-ES9 (speaker system).

- In the interests of user-safety the set should be restored to its original condition and only parts identical to those specified should be used.

COMPACT
disc
DIGITAL AUDIO

CD-R/RW
Playable

5CD CHANGER

This Service Manual is for the CD-ES9, which is a minor-modification model of the CD-ES900. This manual, therefore, describes only the changed points from the service manual. Please refer to the CD-ES900, service manual (No. S2405CDES900/) together with this manual.

DIFFERENCE BETWEEN CD-ES900 AND CD-ES9

REF. NO.	PART NO. ★	★	PART NO. ★	★	DESCRIPTION	CODE
	CD-ES900		CD-ES9			
TRANSFORMER						
△ PT801	RTRNP0518AWZZ	J	RTRNP0521AWZZ	J	Power, Main	BL
RESISTORS						
R123,124	VRS-CY1JB562J	J	VRS-CY1JB682J	J	6.8 kohms, 1/16W	AA
R641	VRS-CY1JB103J	J	VRD-ST2CD562	J	5.6 kohms, 1/6W	AA
R642	VRD-ST2CD103J	J	VRD-ST2CD562J	J	5.6 kohms, 1/6W	AA
R692,693	VRD-ST2CD273J	J	VRD-ST2CD333J	J	33 kohms, 1/6W	AA
R942,943	VRS-VV3DA681J	J	VRS-VV3DA682J	J	6.8 kohms, 2W	AA
OTHER CIRCUITRY PART						
△ F805	QFS-D502BSJNi	J	QFS-D602DAWni	J	Fuse, 6A/125V	
CABINET PARTS						
201	CCABA5530AW01	J	CCABA5769AW01	J	Front Panel Ass'y	
201-1	—		—		Front Panel (Not Replacement Item)	—
201-2	GCōVA1521AWSA	J	Same as CD-ES900		Cover, Cassette [Tape 1]	AK
201-3	GCōVA1522AWSA	J	Same as CD-ES900		Cover, Cassette [Tape 2]	AK
201-4	GDōRF0127AWSA	J	Same as CD-ES900		Holder, Cassette [Tape 1]	AE
201-5	GDōRF0128AWSA	J	Same as CD-ES900		Holder, Cassette [Tape 2]	AE
201-6	HDECQ1108AWSA	J	Same as CD-ES900		Panel, Cassette [Tape 1]	AE
201-7	HDECQ1109AWSA	J	Same as CD-ES900		Panel, Cassette [Tape 2]	AE
201-8	JKNBZ0982AWSA	J	Same as CD-ES900		Button, Disc Number	AE
201-9	MLiF-A001AWZZ	J	Same as CD-ES900		Damper	AD
201-10	JKNBZA023AWSB	J	JKNBZA023AWSD	J	Button, Operation A	
201-11	JKNBZA024AWSB	J	JKNBZA024AWSD	J	Button, Operation B	
201-12	JKNBZ0985AWSA	J	Same as CD-ES900		Button, Function	AE
201-13	JKNBZ0986AWSA	J	Same as CD-ES900		Button, Memory	AE
201-14	JKNBZ0987AWSA	J	Same as CD-ES900		Button, Tuning	AE
201-15	JKNBZ0991AWSA	J	Same as CD-ES900		Button, Power	AF
201-16	GCōVA1533AWSA	J	Same as CD-ES900		Cover, Timer	AC

★ MARK: SPARE PARTS-DELIVERY SECTION

Parts marked with "△" are important for maintaining the safety of the set.

Be sure to replace parts with specified ones for maintaining the safety and performance of the set.

www.rtv-horvat-dj.hr

CD-ES9

REF. NO.	PART NO. ★	PART NO. ★	DESCRIPTION	CODE
	CD-ES900	CD-ES9		
201-17	HBDGB1007AWSA J	Same as CD-ES900	Badge, SHARP	AD
201-18	MSPRDA002AWFJ J	Same as CD-ES900	Spring, Cassette [Tape 1]	AB
201-19	MSPRDA003AWFJ J	Same as CD-ES900	Spring, Cassette [Tape 2]	AB
201-20	HDECQA039AWSA J	Same as CD-ES900	Volume Knob Ring, A	AH
201-21	HDECQ1106AWSA J	Same as CD-ES900	Volume Knob Ring, B	AF
201-22	HDECQ1107AWSA J	HDECQA058AWSA J	Decoration Plate, Amp	AH
201-23	MLōKC0014AWZZ J	Same as CD-ES900	Lock, Cassette [Tape 1]	AC
201-24	MLōKC0015AWZZ J	Same as CD-ES900	Lock, Cassette [Tape 2]	AC
201-25	MSPRD0196AWFJ J	Same as CD-ES900	Spring, Cassette Lock [Tape 1]	AB
201-26	MSPRD0197AWFJ J	Same as CD-ES900	Spring, Cassette Lock [Tape 2]	AC
204	GiTARA022AWSA J	GiTARA143AWSA J	Rear Panel, B [CD-SE9]	AK
215	PSHEPA007AWZZ J	Not Used	Sheet, Edge Light	
231	Not Used	PFLT-A006AWZZ J	Felt	AB
232	Not Used	PCōVQ7004AWFW J	Cover, Fan	AK
617	Not Used	LX-JZ0036AWFD J	Screw, Special	AB
ACCESSORIES				
	TiNSEA002AWZZ J	TiNSEA055AWZZ J	Operation Manual	AE
	TiNSZA003AWZZ J	TiNSZA069AWZZ J	Quick Guide	AD
	TLABZA092AWZZ J	TLABZA113AWSA J	Energy Star Label (Set)	
P.W.B. ASSEMBLY (Not Replacement Item)				
PWB-A1~3	92LPWB5529MANS J	92LPWB5769MANS J	Main/Display/Spacer (Combined Ass'y)	—
△ PWB-B1, 2	92LPWB5529PWRS J	92LPWB5769PWRS J	Power/Game Input (Combined Ass'y)	—

★ MARK: SPARE PARTS-DELIVERY SECTION

Parts marked with “△” are important for maintaining the safety of the set.

Be sure to replace parts with specified ones for maintaining the safety and performance of the set.

DIFFERENCE BETWEEN CP-ES900 AND CP-ES9

REF. NO.	PART NO. ★	PART NO. ★	DESCRIPTION	CODE
	CP-ES900	CP-ES9		
SPEAKER BOX PART				
907	TSPC-A013AWZZ J	TSPC-A038AWZZ J	Label, Specifications [CD-SE9]	AC

★ MARK: SPARE PARTS-DELIVERY SECTION

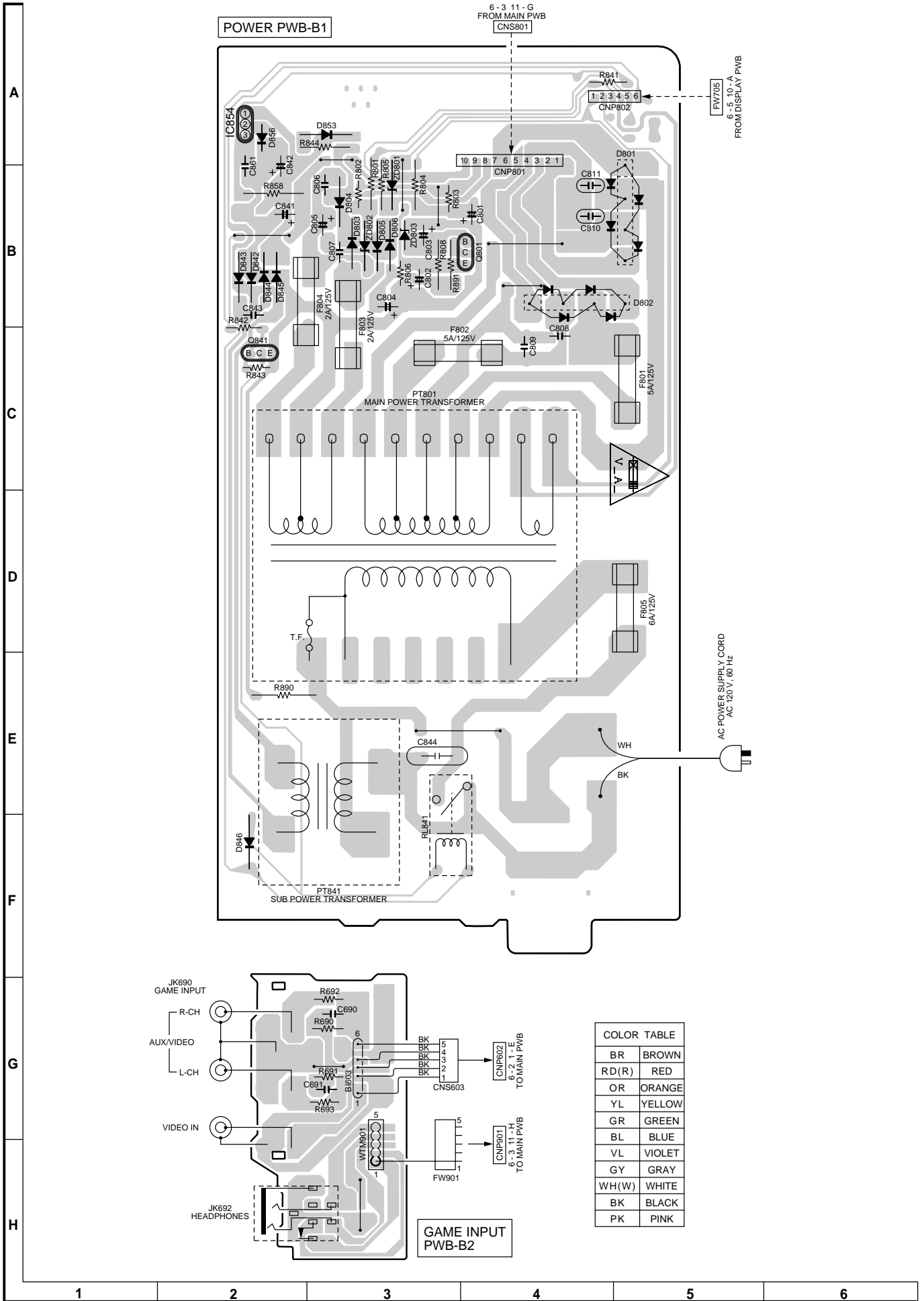
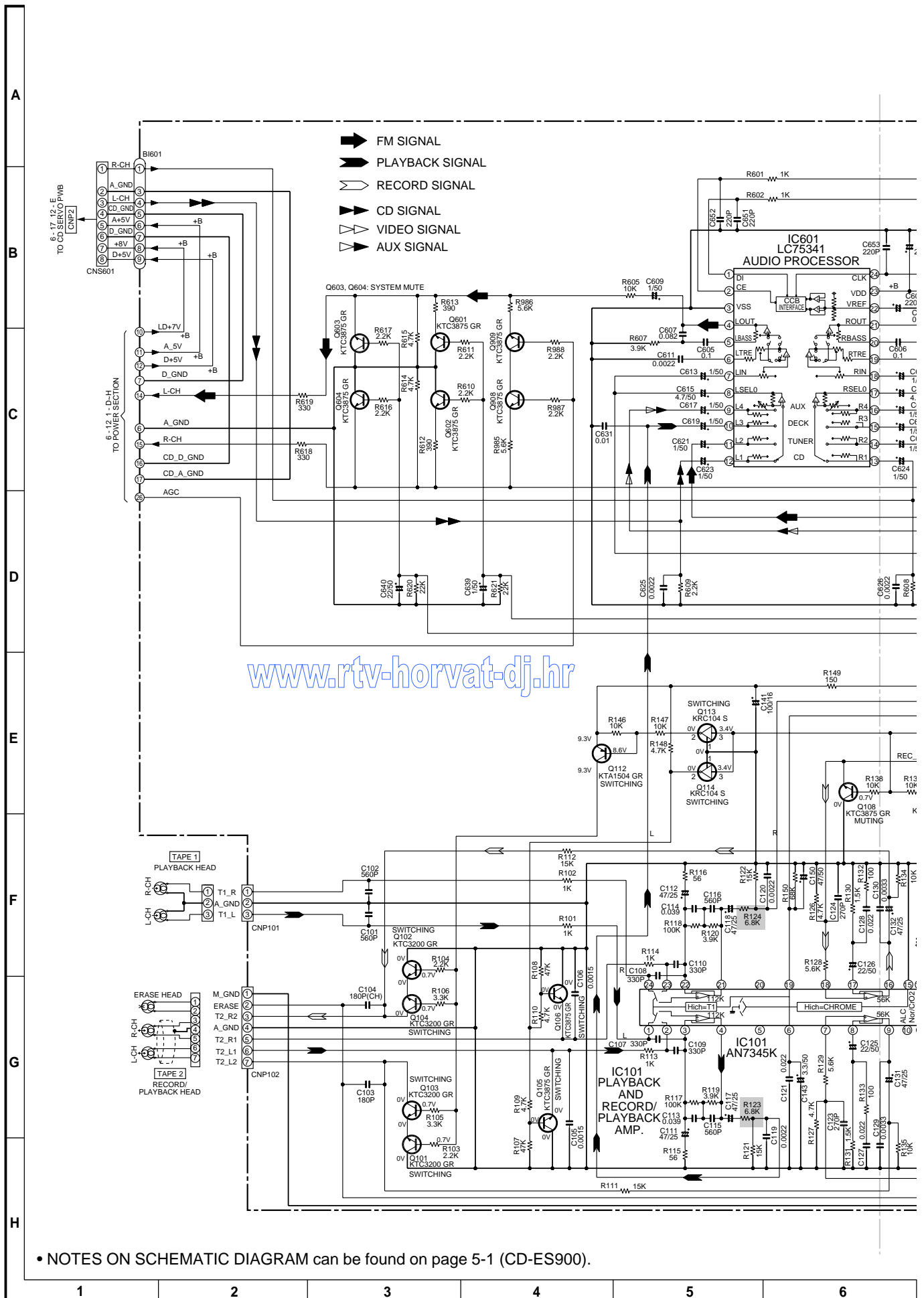

Figure 3 WIRING SIDE OF PWB (1/1)



• NOTES ON SCHEMATIC DIAGRAM can be found on page 5-1 (CD-ES900).

Figure 4 SCHEMATIC DIAGRAM (1/3)

: Changed

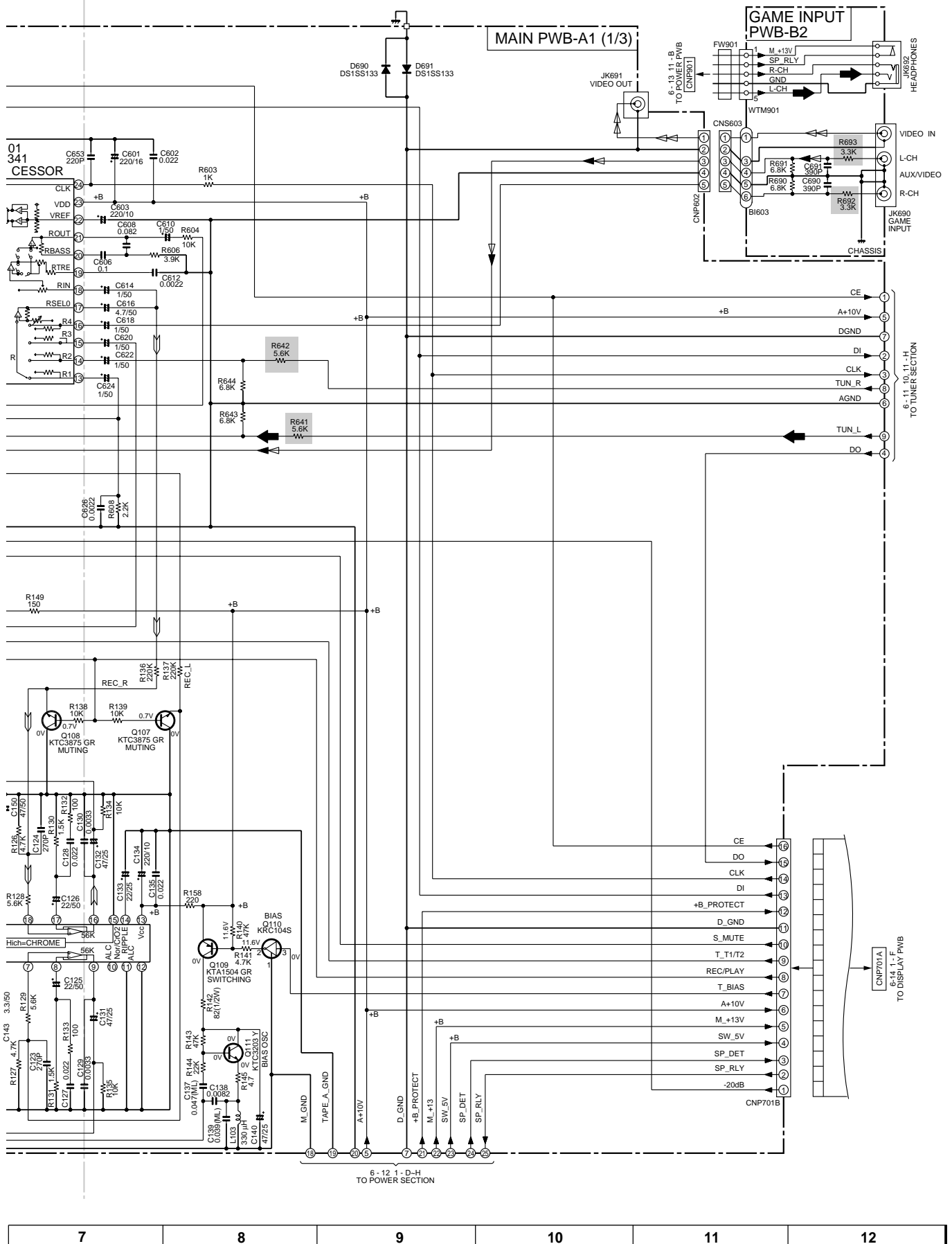
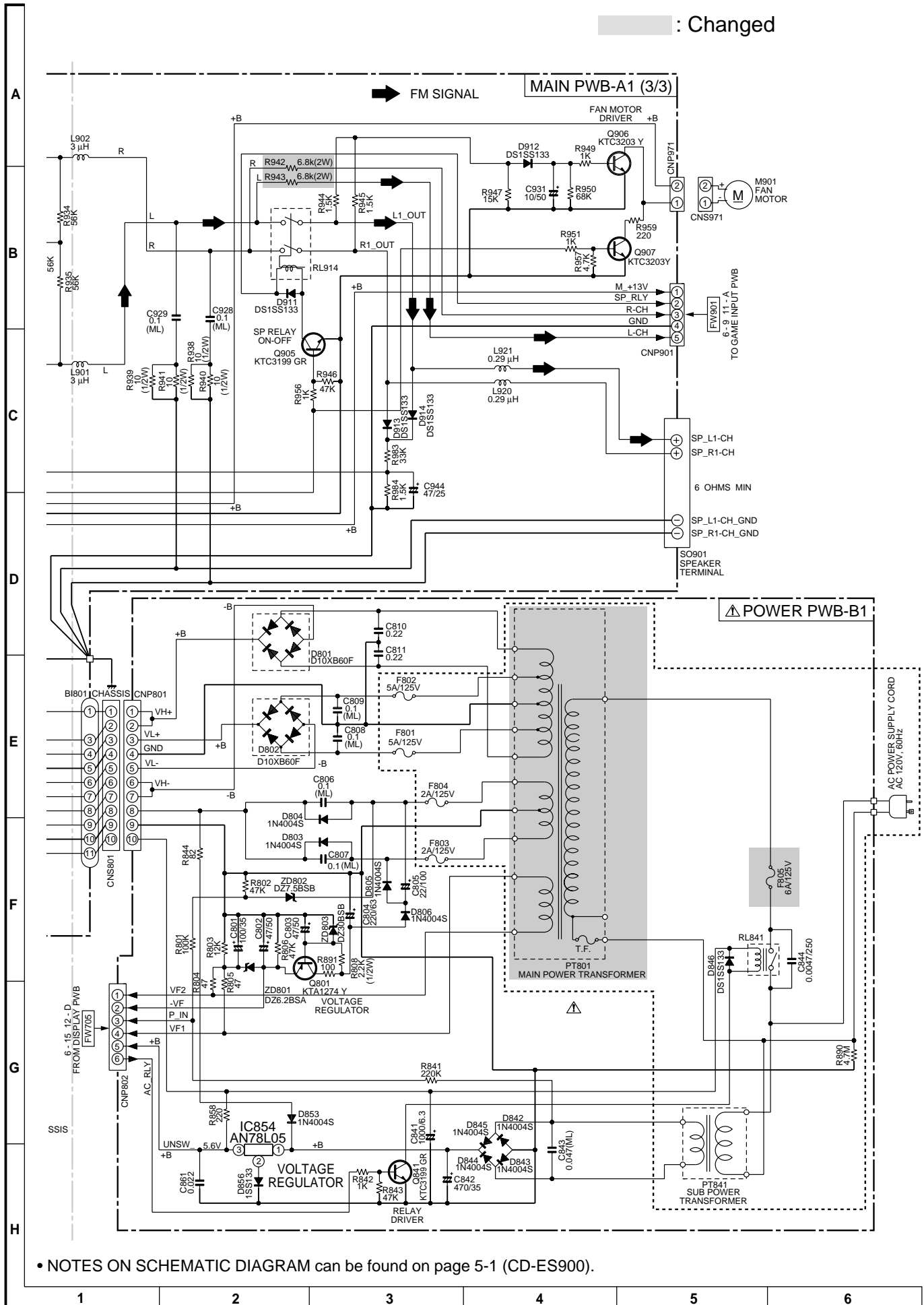

Figure 5 SCHEMATIC DIAGRAM (2/3)

Changed



• NOTES ON SCHEMATIC DIAGRAM can be found on page 5-1 (CD-ES900).

Figure 6 SCHEMATIC DIAGRAM (3/3)

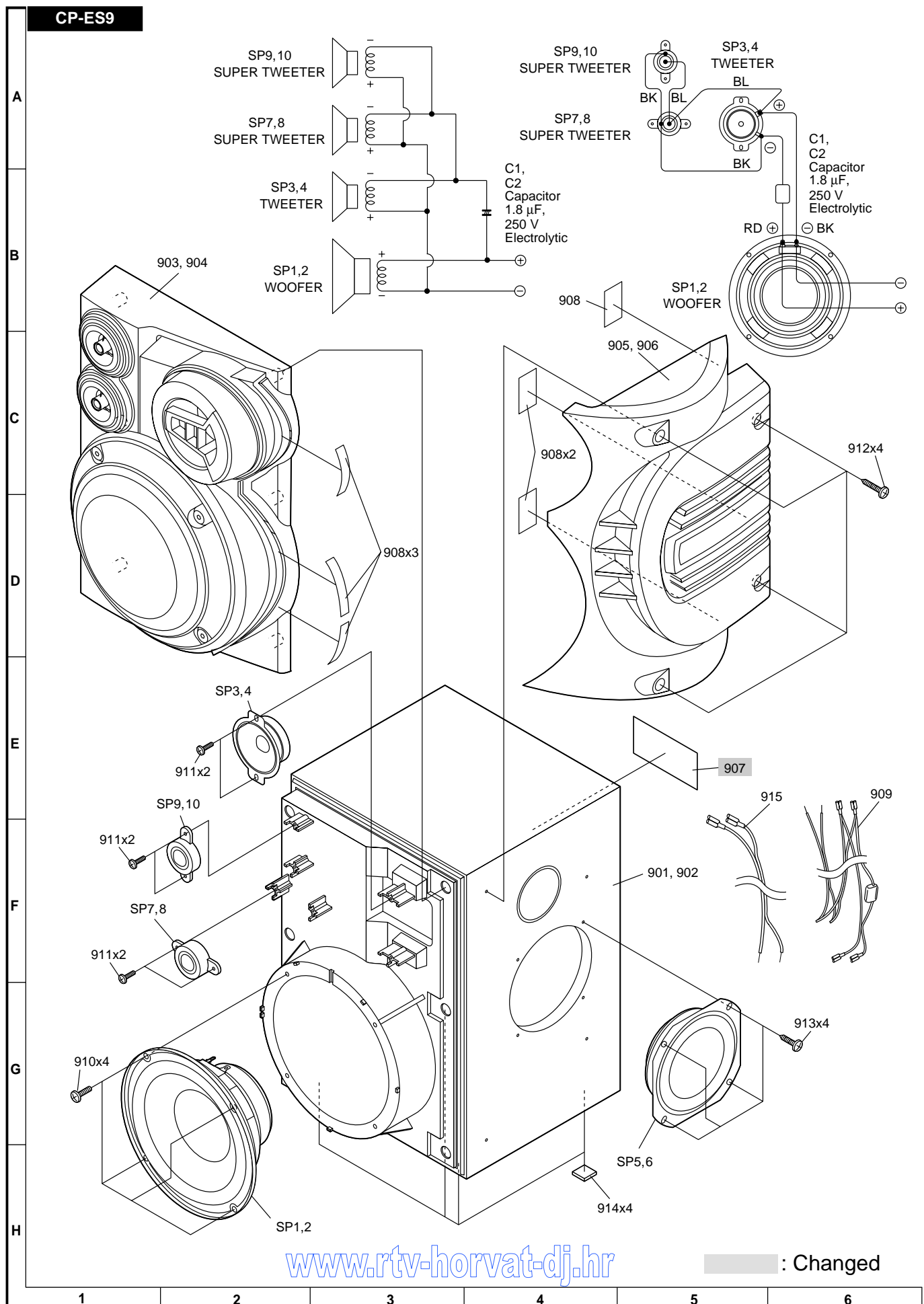

Figure 8 SPEAKER EXPLODED VIEW

IMPORTANT SERVICE NOTES

BEFORE RETURNING THE AUDIO PRODUCT

BEFORE RETURNING THE AUDIO PRODUCT

(Fire & Shock Hazard)

Before returning the audio product to the user, perform the following safety checks.

1. Inspect all lead dress to make certain that leads are not pinched or that hardware is not lodged between the chassis and other metal parts in the audio product.
2. Inspect all protective devices such as insulating materials, cabinet, terminal board, adjustment and compartment covers or shields, mechanical insulators etc.
3. To be sure that no shock hazard exists, check for leakage current in the following manner.
 - * Plug the AC line cord directly into a 120 volt AC outlet.
 - * Using two clip leads, connect a 1.5 kohm, 10 watt resistor paralleled by a 0.15 μ F capacitor in series with all exposed metal cabinet parts and a known earth ground, such as conduit or electrical ground connected to earth ground.
 - * Use a VTVM or VOM with 1000 ohm per volt, or higher, sensitivity to measure the AC voltage drop across the resistor (See diagram).
 - * Connect the resistor connection to all exposed metal parts having a return path to the chassis (antenna, metal cabinet, screw heads, knobs and control shafts, escutcheon, etc.) and measure the AC voltage drop across the resistor.

All check must be repeated with the AC line cord plug connection reversed.

Any reading of 0.3 volt RMS (this corresponds to 0.2 milliamp. AC.) or more is excessive and indicates a potential shock hazard which must be corrected before returning the audio product to the owner.

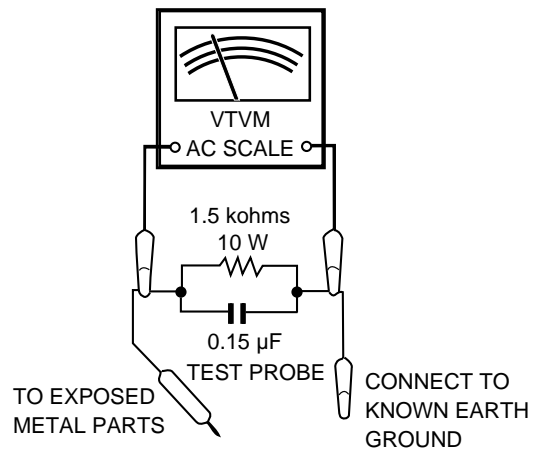

CHAPTER 1. GENERAL DESCRIPTION

[1] Specifications

FOR A COMPLETE DESCRIPTION OF THE OPERATION OF THIS UNIT, PLEASE REFER TO THE OPERATION MANUAL.

CD-ES900/CD-ES99

■ General

Power source	AC 120 V, 60 Hz
Power consumption	175 W
Dimensions	Width: 10-1/4" (260 mm) Height: 13" (330 mm) Depth: 12-7/8" (326 mm)
Weight	22.1 lbs. (10.0 kg)

■ Amplifier

Output power	200 watts minimum RMS per channel into 6 ohms from 100 Hz to 20 kHz, 10% total harmonic distortion
Output terminals	Speakers: 6 ohms Headphones: 16 - 50 ohms (recommended: 32 ohms) Video output: 1Vp-p
Input terminals	Game/Auxiliary (audio signal): 500 mV/47 k ohms Game/Video: 1Vp-p

■ CD player

Type	5-disc multi-play compact disc player
Signal readout	Non-contact, 3-beam semiconductor laser pickup
D/A converter	1-bit D/A converter
Frequency response	20 - 20,000 Hz
Dynamic range	90 dB (1 kHz)

■ Tuner

Frequency range	FM: 87.5 - 108.0 MHz AM: 530 - 1,720 kHz
------------------------	---

■ Cassette deck

Frequency response	50 - 14,000 Hz (normal tape)
Signal/noise ratio	55 dB (TAPE-1 playback) 50 dB (TAPE-2 recording/playback)
Wow and flutter	0.3 % (WRMS)

CP-ES900/CP-ES99

Type	3-way type speaker system with passive radiator Super tweeter x 2 2" (5 cm) tweeter x 1 6-1/2" (16 cm) woofer x 1 4" (10 cm) passive radiator
Maximum input power	400 W
Rated input power	200 W
Impedance	6 ohms
Dimensions	Width: 10-7/8" (277 mm) Height: 13" (330 mm) Depth: 11" (279 mm)
Weight	10.6 lbs. (4.8 kg)/each

Specifications for this model are subject to change without prior notice.

[2] Names of parts

CD-ES900/CD-ES99

■ Front panel

1. Disc Trays
2. Timer Indicator
3. Power On/Stand-by Button
4. CD Track Up or Fast Forward, Tape 2 Fast Forward, Tuner Preset Up, Time Up Button
5. Clock/Timer Button
6. Tuning Up Button
7. Tuning Down Button
8. CD Track Down or Fast Reverse, Tape 2 Rewind, Tuner Preset Down, Time Down Button
9. Equalizer Mode Select Button
10. Tape 1 Cassette Compartment
11. Headphone Jack
12. Game/Video Input Jacks
13. Disc Number Select Buttons
14. CD Direct Play Button
15. Disc Tray Open/Close Button
16. CD Play or Repeat, Tape Play Button
17. Memory/Set Button
18. Tape 2 Record Pause Button
19. CD or Tape Stop Button
20. Extra Bass/Demo Mode Button
21. Volume Control
22. Tape 2 Cassette Compartment
23. Tuner (Band) Button
24. CD Button
25. Tape (1 - 2) Button
26. Game/Video Button

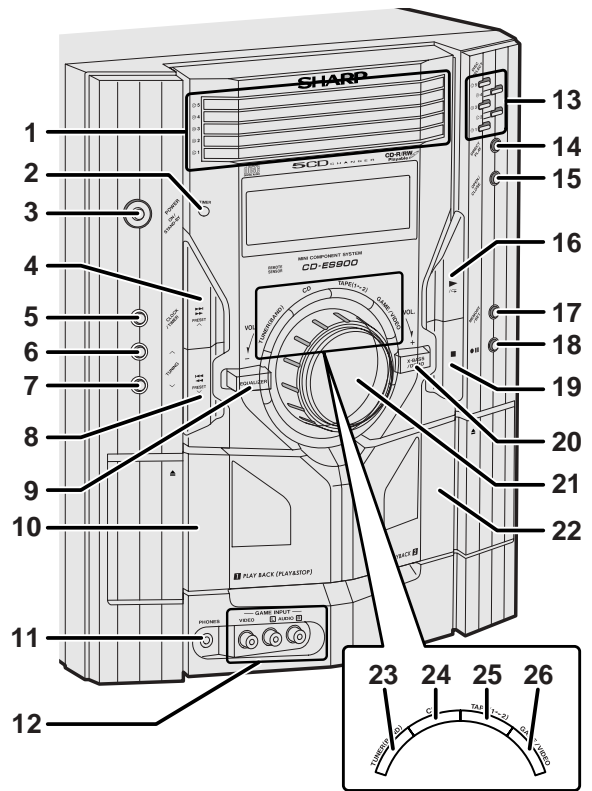

■ Display

1. Disc Number Indicators
2. CD Play Indicator
3. CD Pause Indicator
4. Memory Indicator
5. CD Repeat Play Indicator
6. CD Indicator
7. Extra Bass Indicator
8. Tape Play Indicator
9. FM Stereo Mode Indicator
10. Daily Timer Indicator
11. FM Stereo Receiving Indicator
12. Tape 2 Record Indicator
13. Sleep Indicator
14. Timer Play Indicator
15. Timer Recording Indicator

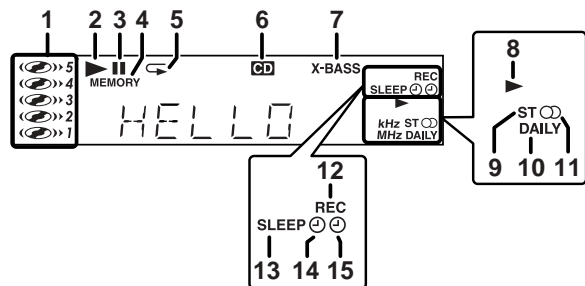

■ Rear panel

1. Cooling Fan
2. AC Power Cord
3. FM 75 Ohms Antenna Terminal
4. FM Antenna Ground Terminal
5. AM Loop Aerial Jack
6. Video Output Jack
7. Speaker Terminals

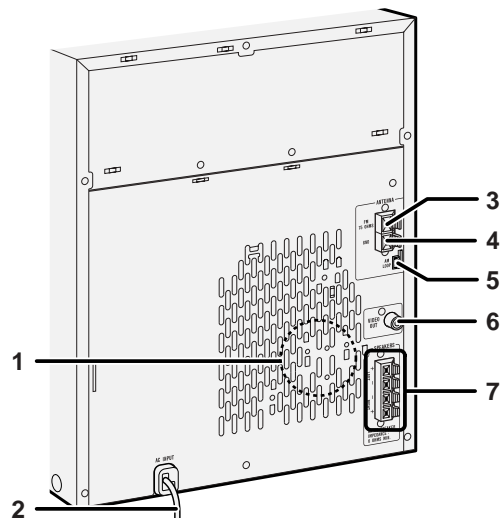

CD-ES900/CD-ES99

Remote control

1. Remote Control Transmitter
2. Disc Number Select Buttons
3. Disc Direct Search Buttons
4. CD Clear/Dimmer Button
5. Memory/Set Button
6. CD Track Down or Fast Reverse, Tape 2 Rewind, Tuner Preset Down, Time Down Button
7. CD Pause Button
8. Tape 2 Record Pause Button
9. Tuner (Band) Button
10. CD Button
11. Tape (1-2) Button
12. Game/Video Button
13. Power On/Stand-by Button
14. Clock/Timer Button
15. CD Random Button
16. CD Track Up or Fast Forward, Tape 2 Fast Forward, Tuner Preset Up, Time Up Button
17. CD or Tape Stop Button
18. CD Play or Repeat, Tape Play Button
19. Extra Bass Button
20. Equalizer Mode Select Button
21. Volume Up and Down Buttons

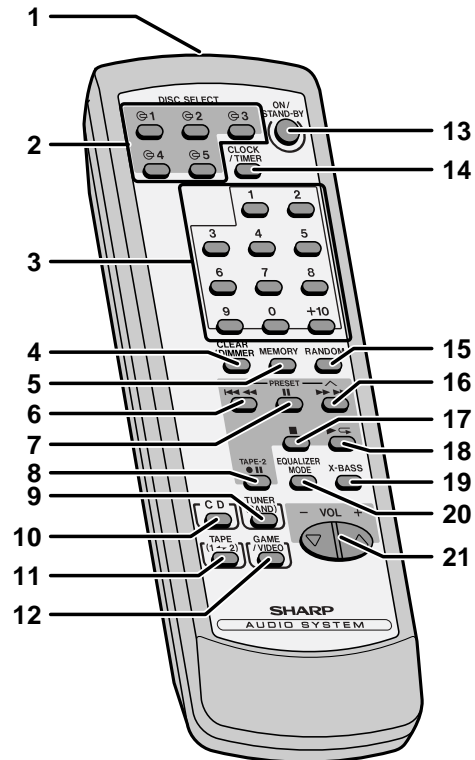

CP-ES900/CP-ES99

1. Tweeter
2. Passive Radiator
3. Woofer
4. Super Tweeters
5. Speaker Wire

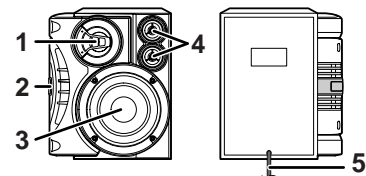

CHAPTER 2. ADJUSTMENTS

[1] Mechanism section

- Driving Force Check

Torque Meter	Specified Value
Play: TW-2111	Tape 1: Over 80 g Tape 2: Over 80 g

- Torque Check

Torque Meter	Specified Value	
	Tape 1	Tape 2
Play: TW-2111	30 to 80 g.cm	30 to 80 g.cm
Fast forward: TW-2231	—	70 to 180 g.cm
	—	70 to 180 g.cm

- Tape Speed

	Test Tape	Adjusting Point	Specified Value	Instrument Connection
Normal speed	MTT-111	Variable Resistor in motor.	3,000 \pm 30 Hz Speaker	Speaker Terminal (Load resistance: 6 ohms)

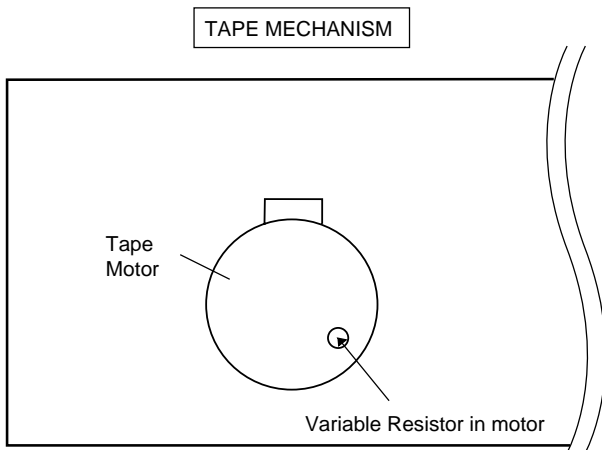

Figure 1

[2] Tuner section

fL: Low-range frequency

fH: High-range frequency

- AM IF/RF

Signal generator: 400 Hz, 30%, AM modulated

Test Stage	Frequency	Frequency Display	Setting/ Adjusting Parts	Instrument Connection
AM IF	450 kHz	1,720 kHz	T351	*1
AM Band Coverage	—	530 kHz	(fL): T306 1.1 \div 0.1 V	*2
AM Tracking	990 kHz	990 kHz	(fL): T303	*1

*1. Input: Antenna Output: TP302

*2. Input: Antenna Output: TP301

- FM RF

Signal generator: 1 kHz, 40 kHz dev., FM modulated

Test Stage	Frequency	Frequency Display	Setting/ Adjusting Parts	Instrument Connection
FM Band Coverage	—	87.50 MHz	T301 (fL): 1.3 V \div 0.1 V	*1
FM RF	98.00 MHz (10-30 dB)	98.00 MHz	L312	*2

*1. Input: Antenna Output: TP301

*2. Input: Antenna Output: Speaker terminal

- FM IF

Signal generator: 10.7 MHz, FM modulated

Test Stage	Frequency	Frequency Display	Setting/ Adjusting Point	Instrument Connection
IF	10.7 MHz	98 MHz	T302 (Turn the core of transformer T302 fully counter-clockwise)	*1

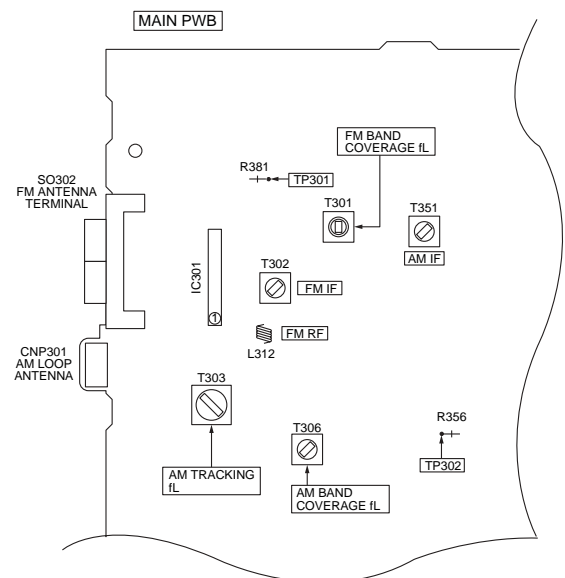

Figure 2 ADJUSTMENT POINTS

[3] CD section

CD Error code description

Error	Explanation
01	When Pickup set inner position, inner switch cannot detect 'ON' level for 10 secs.
10*	CAM error. Can't detect CAM switch when CAM is moving.
11*	When it detect CAM operation error during initialize process.
20*	TRAY error. Can't detect TRAY switch when TRAY is moving.
21*	When it detect TRAY operation error during initialize process.
31	When it change to CD function, DSP cannot read initial data.

* 'CHECKING'

If Error is detected, 'CHECKING' will be displayed instead of 'ER-CD**'.

'ER-CD**' display will only be displayed when error had been detected for the 5th times.

Standard Specification of Stereo System Error Message Display Contents

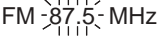
Error Contents	DISPLAY	Notes	
CD	Pickup Mechanism Error.	'ER-CD01'	PU-IN SW Detection NG.
	CD Changer Mechanism Error.	'ER-CD**' (*)	10: CAM SW Detection NG during normal operation. 11: CAM SW Detection NG during initialize process. 20: TRAY SW Detection NG during normal operation. 21: TRAY SW Detection NG during initialize process.
	CD DSP Communication Error.	'ER-CD31'	DSP COMMUNICATION ERROR
	Focus Not Match/IL Time Over	'NO DISC'	
TUNER	PLL Unlock	FM  87.5 MHz	PLL UNLOCK

(*) CHECKING:

If Error is detected, 'CHECKING' will be displayed instead of 'ER-CD**'. 'ER-CD**' display will only be displayed when error had been detected for the 5th times.

Speaker abnormal detection and +B PROTECTION display.

In case speaker abnormal detection or +B PROTECTION had occurred, it can be checked by pressing 'POWER', '■' and 'X-BASS' button. Micro Computer version number will be displayed as "J*****".

Press 'VIDEO/AUX' button during version number display and then press 'POWER', 'MEMORY/SET' and 'VIDEO/AUX' button.

Display will show "S**B**". S is referring to speaker abnormal detection and B is referring to +B PRPTECTION. ** is in hex values.

+B PROTECTION is condition when irregular process occur on power supply line.

BEFORE TRANSPORTING THE UNIT

The following process need to be taken after set tapering/parts replacement.

1. Press the ON/STAND-BY button to enter stand-by mode.
2. While pressing down the ■ button and the X-BASS/DEMO button, press the ON/STAD-BY button.
The Micro Computer version number will be displayed as "J*****".
3. Press OPEN/CLOSE button until "WAIT" ↓ "FINISHED" appears.
4. Unplug the AC cord and the unit is ready for transporting.

[4] CD Changer mechanism section

- A number in the drawing sheet is the number of the parts guide (CHANGER MECHANISM PARTS).

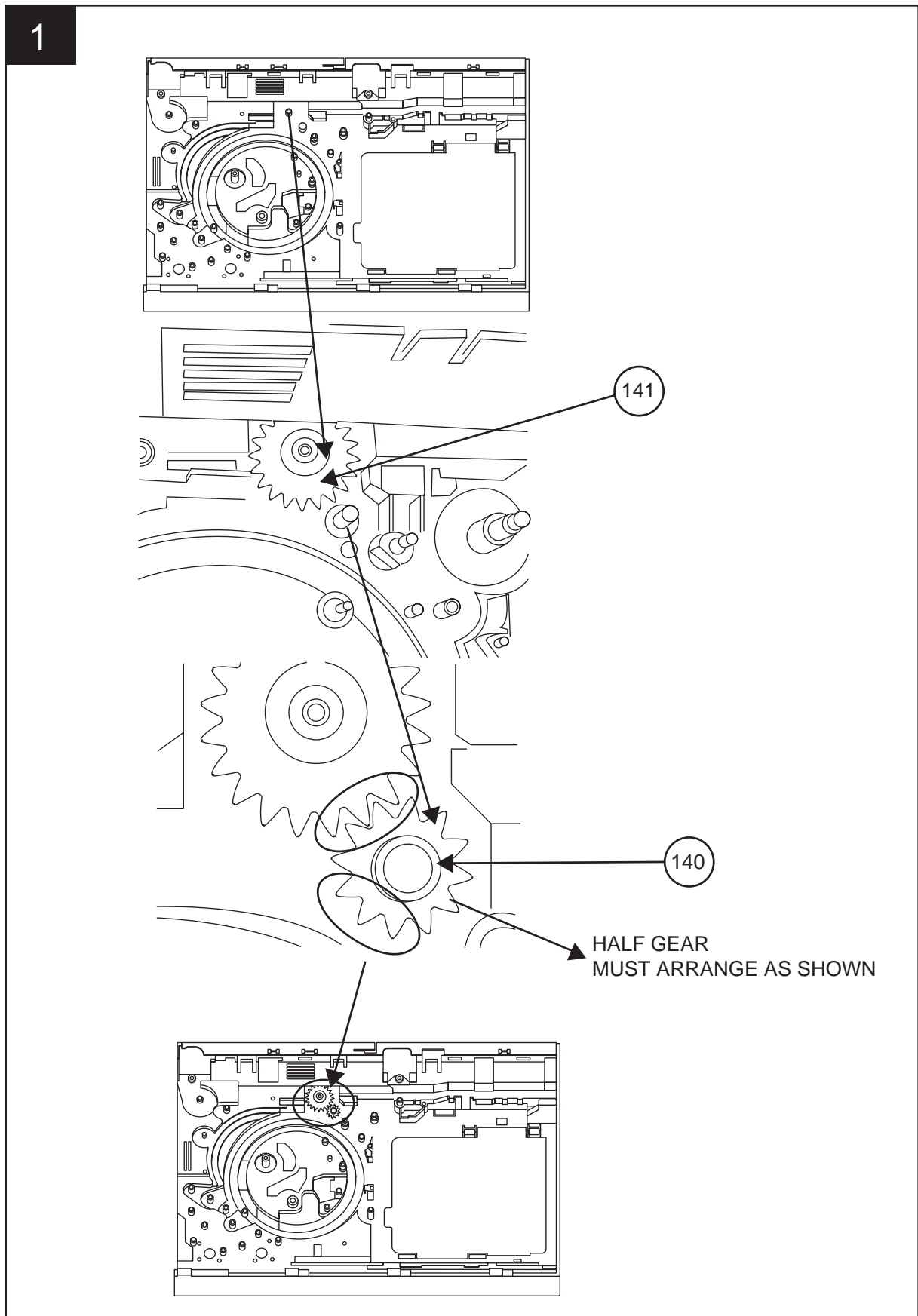

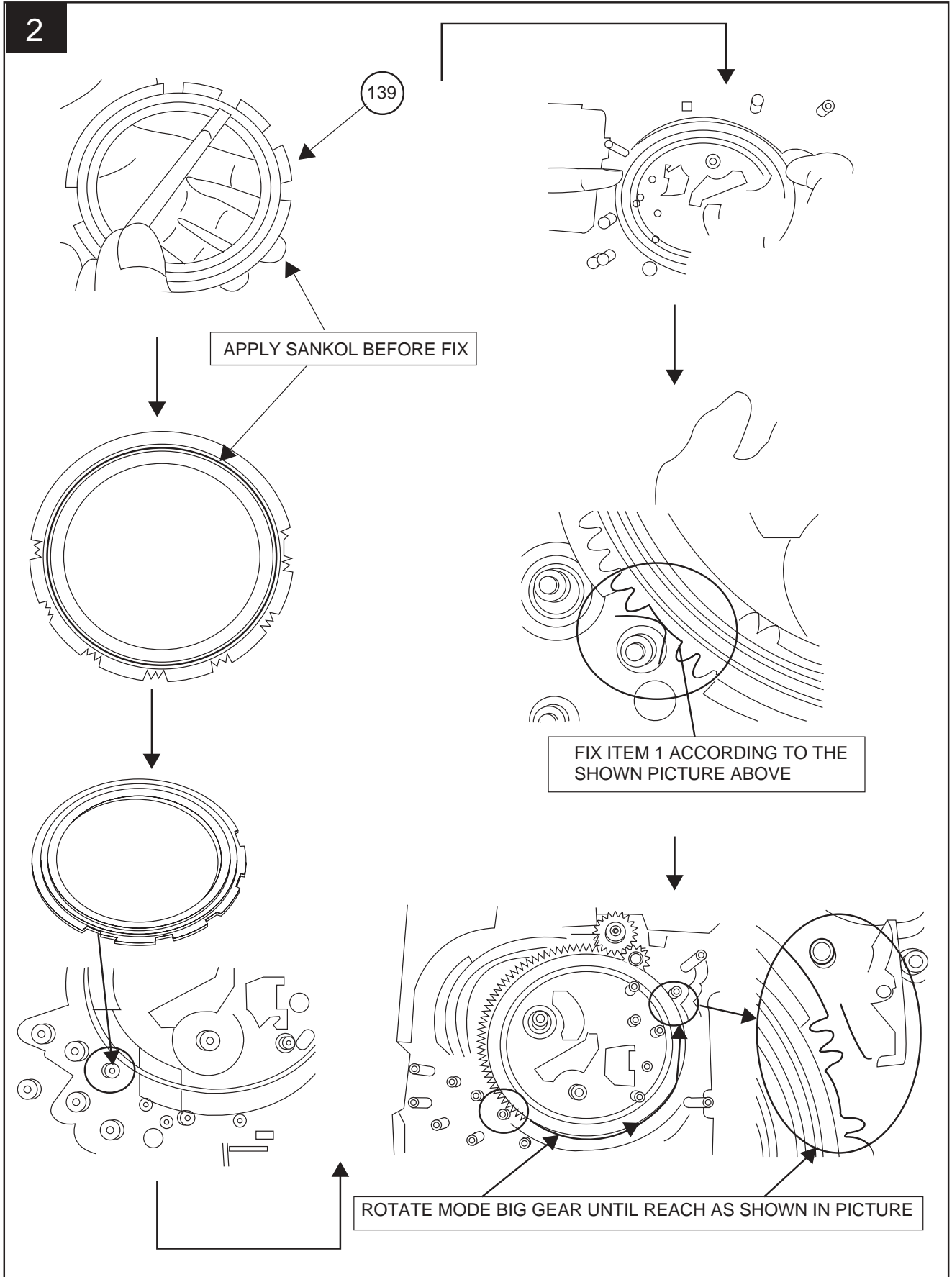

3

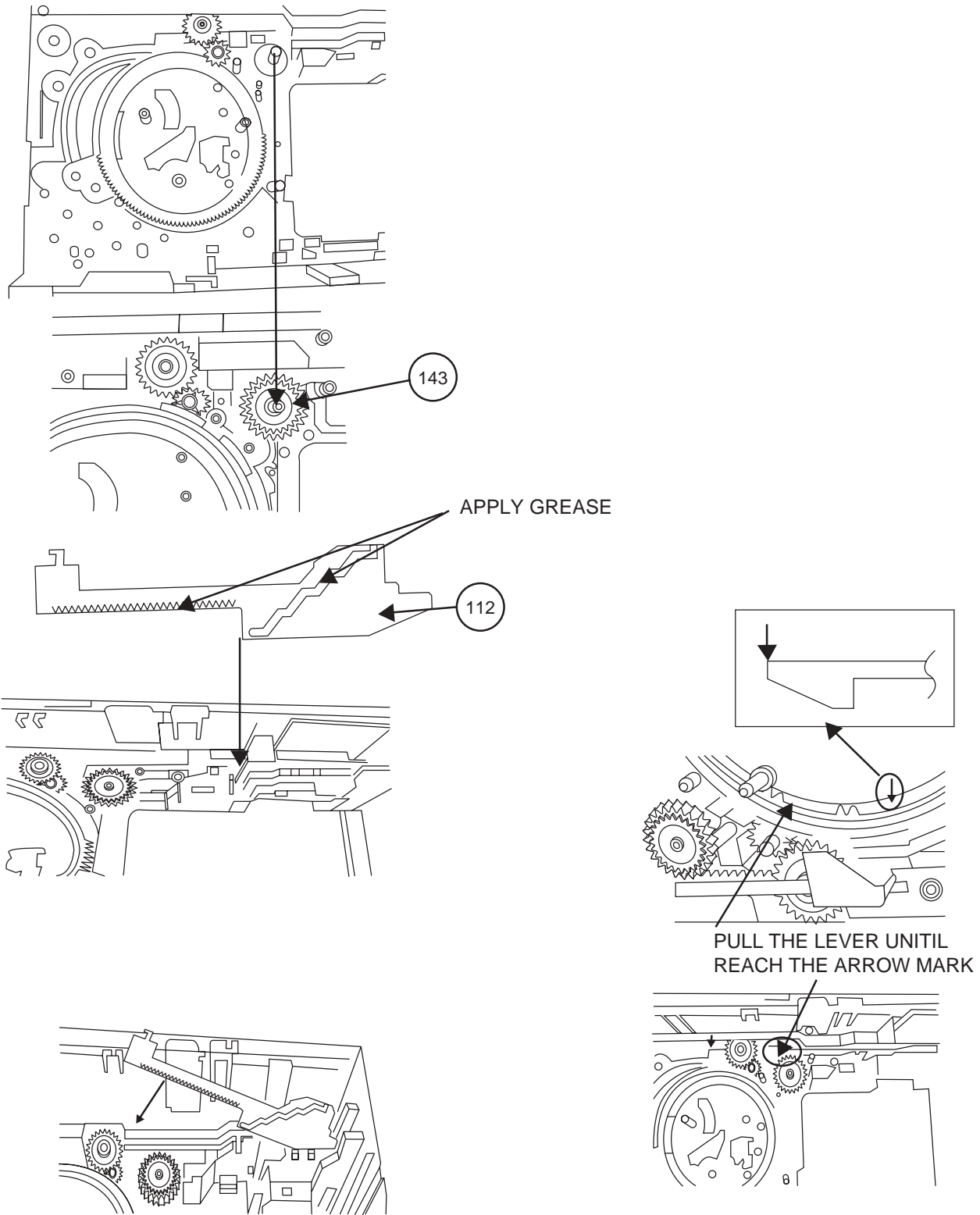

4

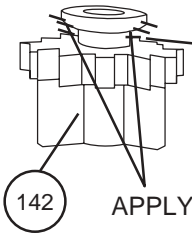
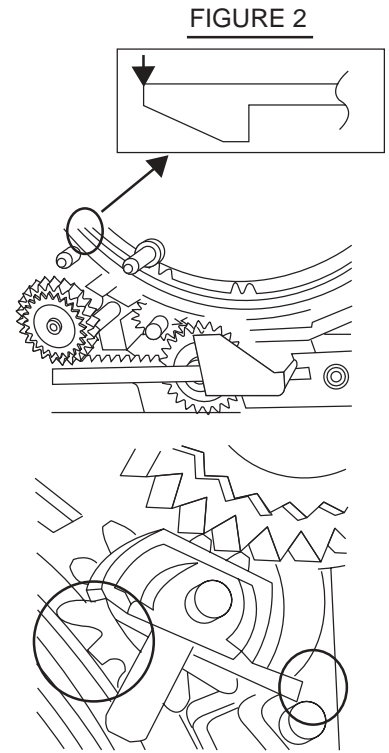
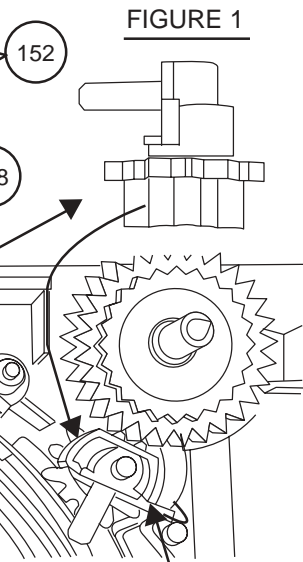
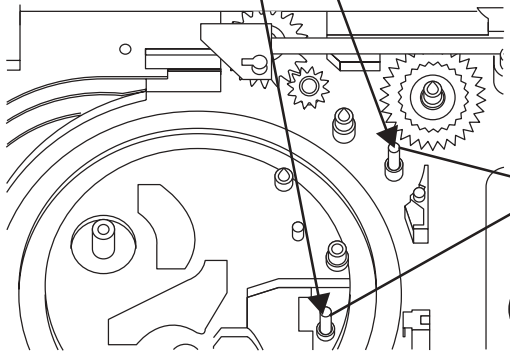
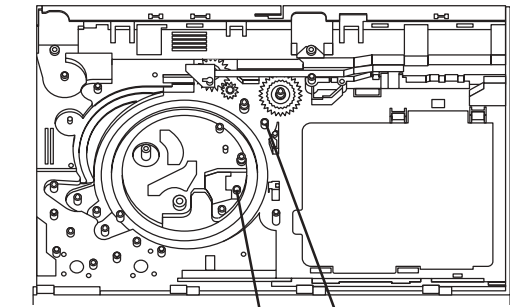

142 APPLY GREASE

SLOT CLAMP SW AM INSIDE BASE SLOT

5

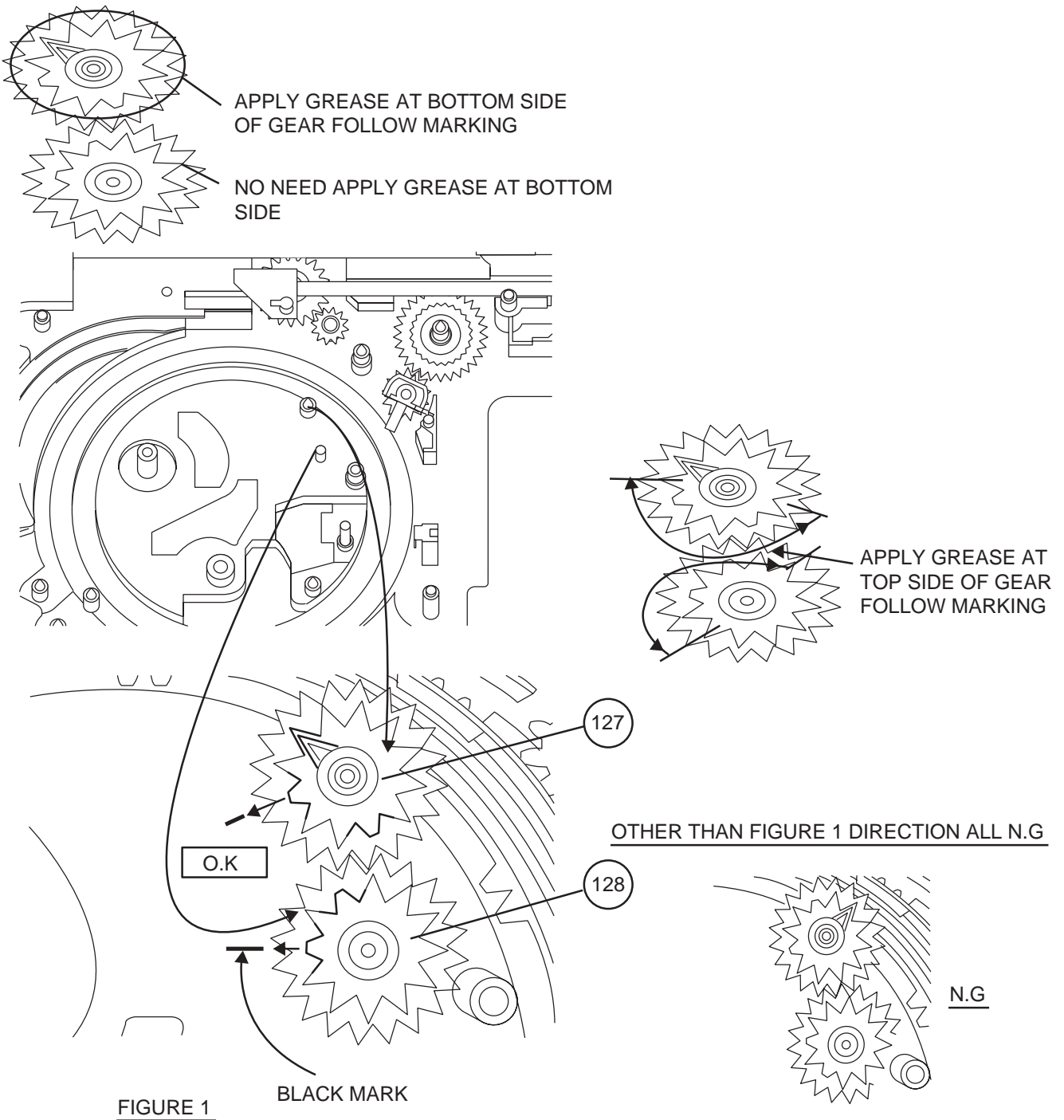

6

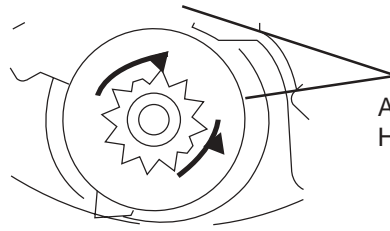
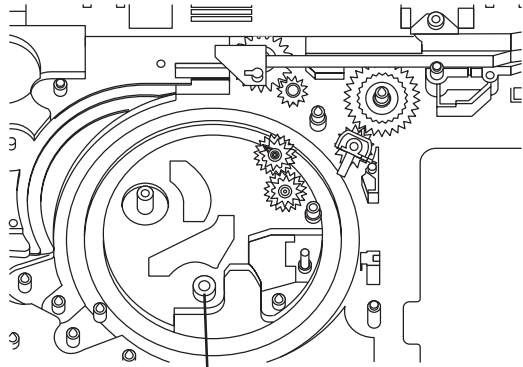

APPLY GREASE AT
HALF GEAR AREA

ROTATE CLOCKWISE UNTIL REACH HERE (MAXIMUM)

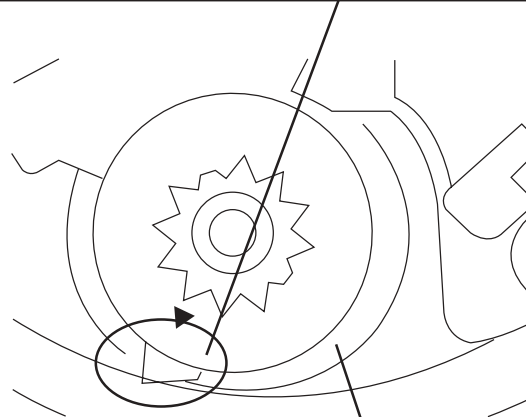
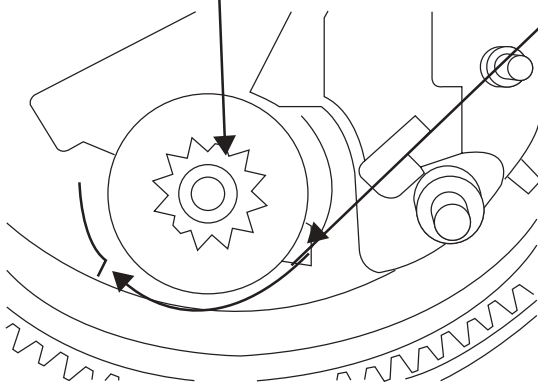

129

7

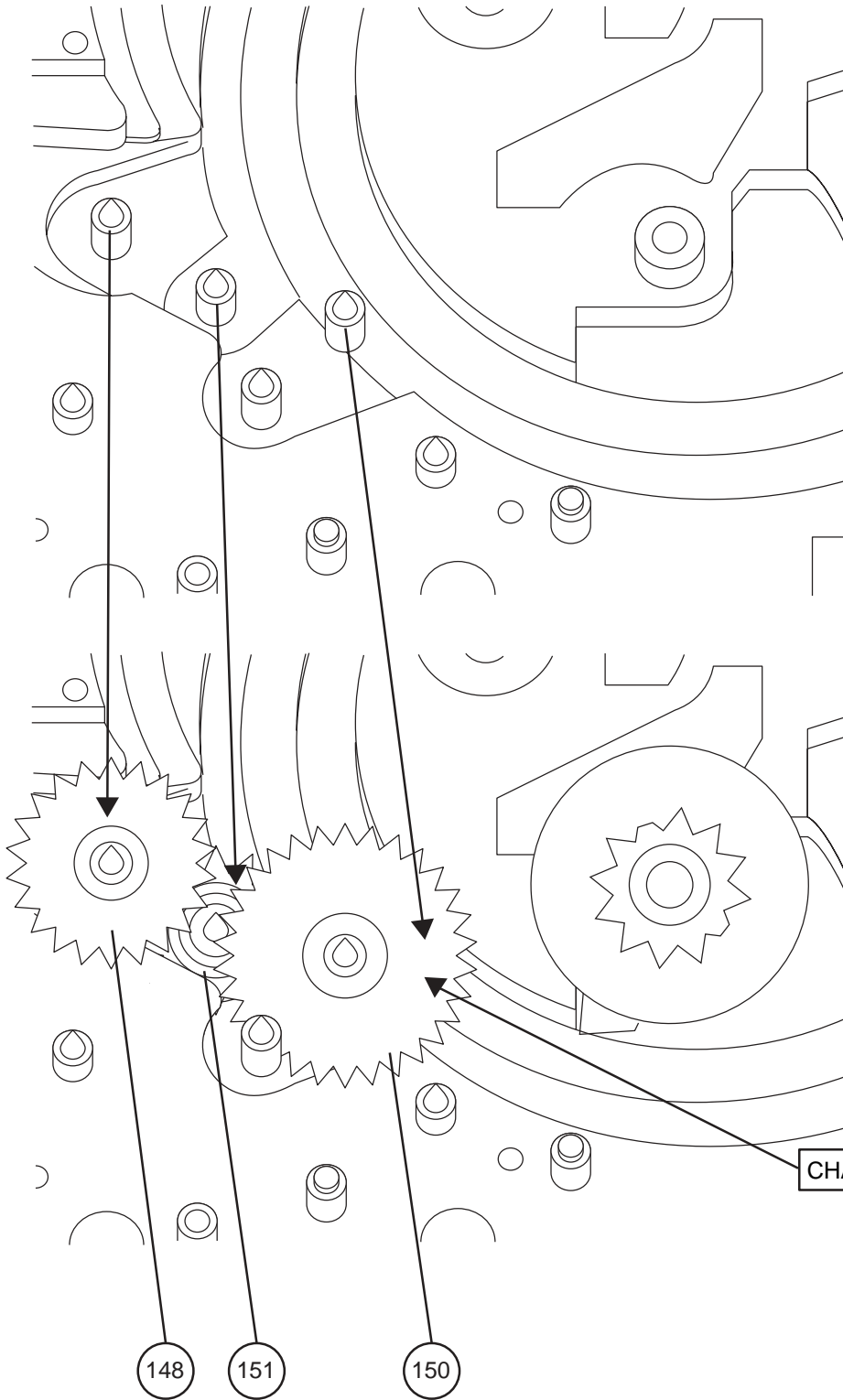

8



MUST FREE FROM GREASE THE SHOWN AREA

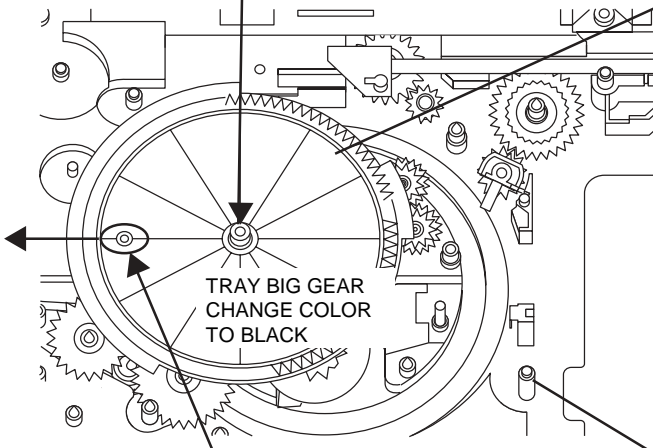
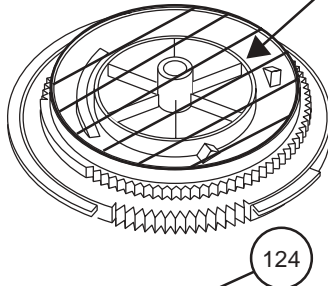
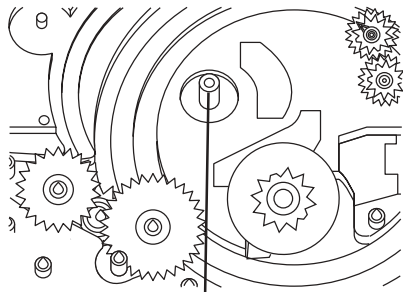
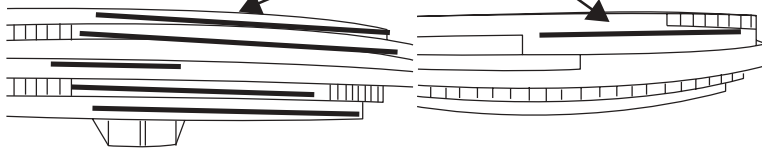
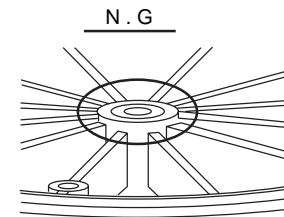
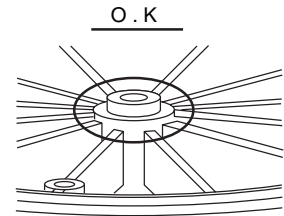

SHOWN HOLE MUST FACING ARROW DIRECTION

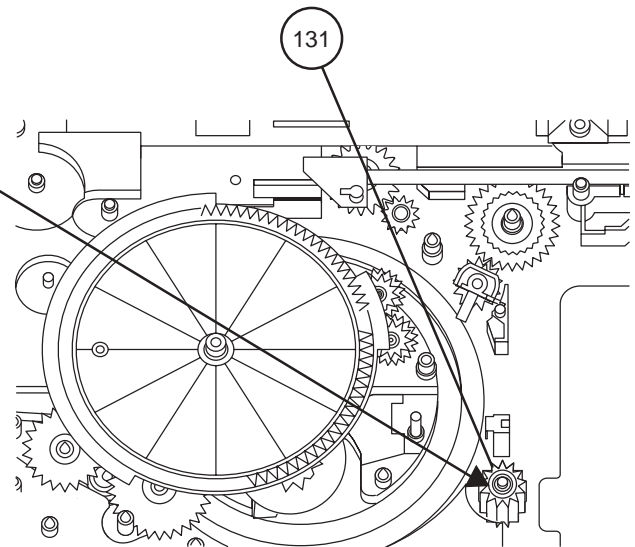

9

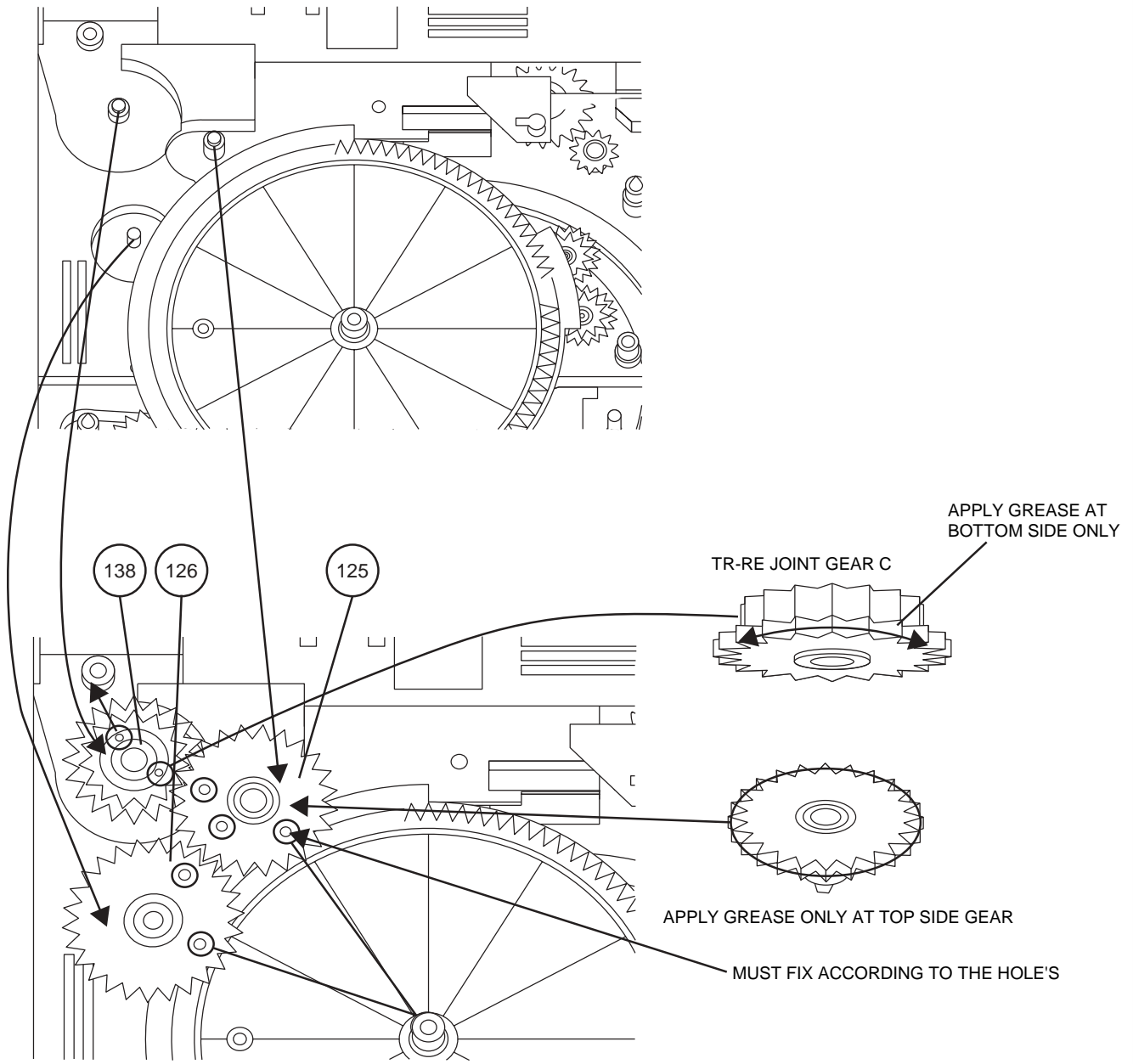

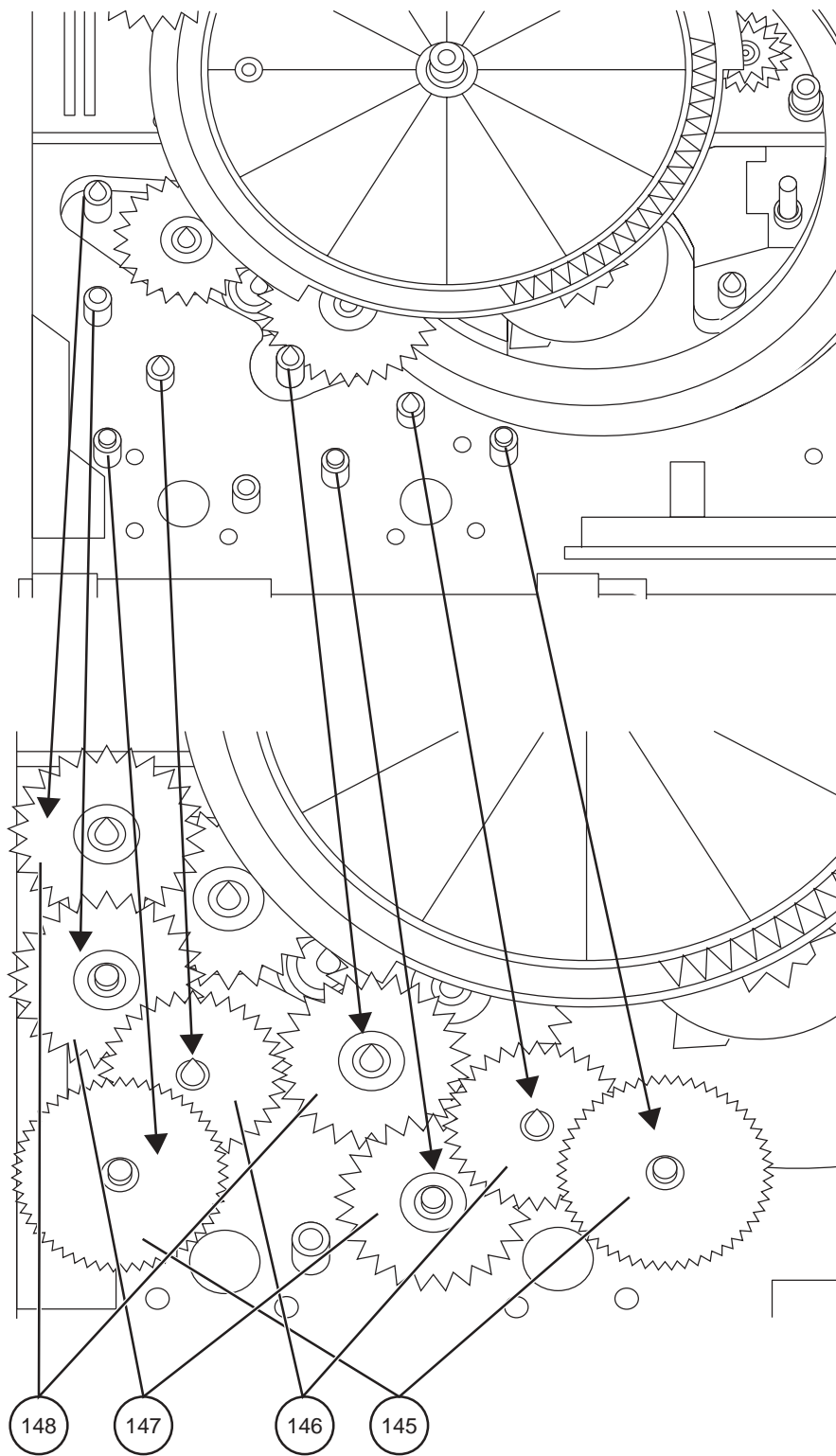

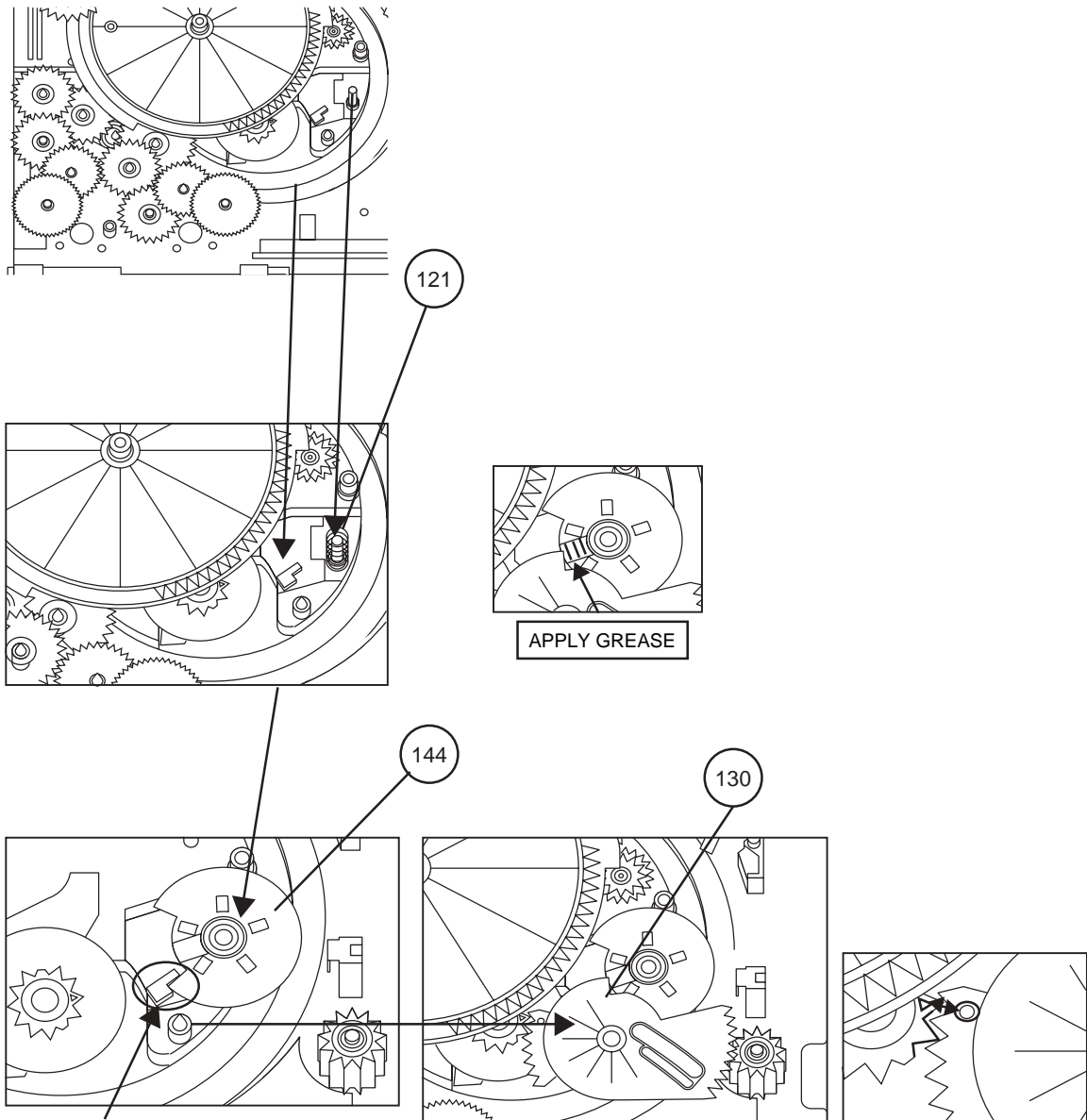

WHEN FIXING ITEM 2 MUST FOLLOW AS SHOWN

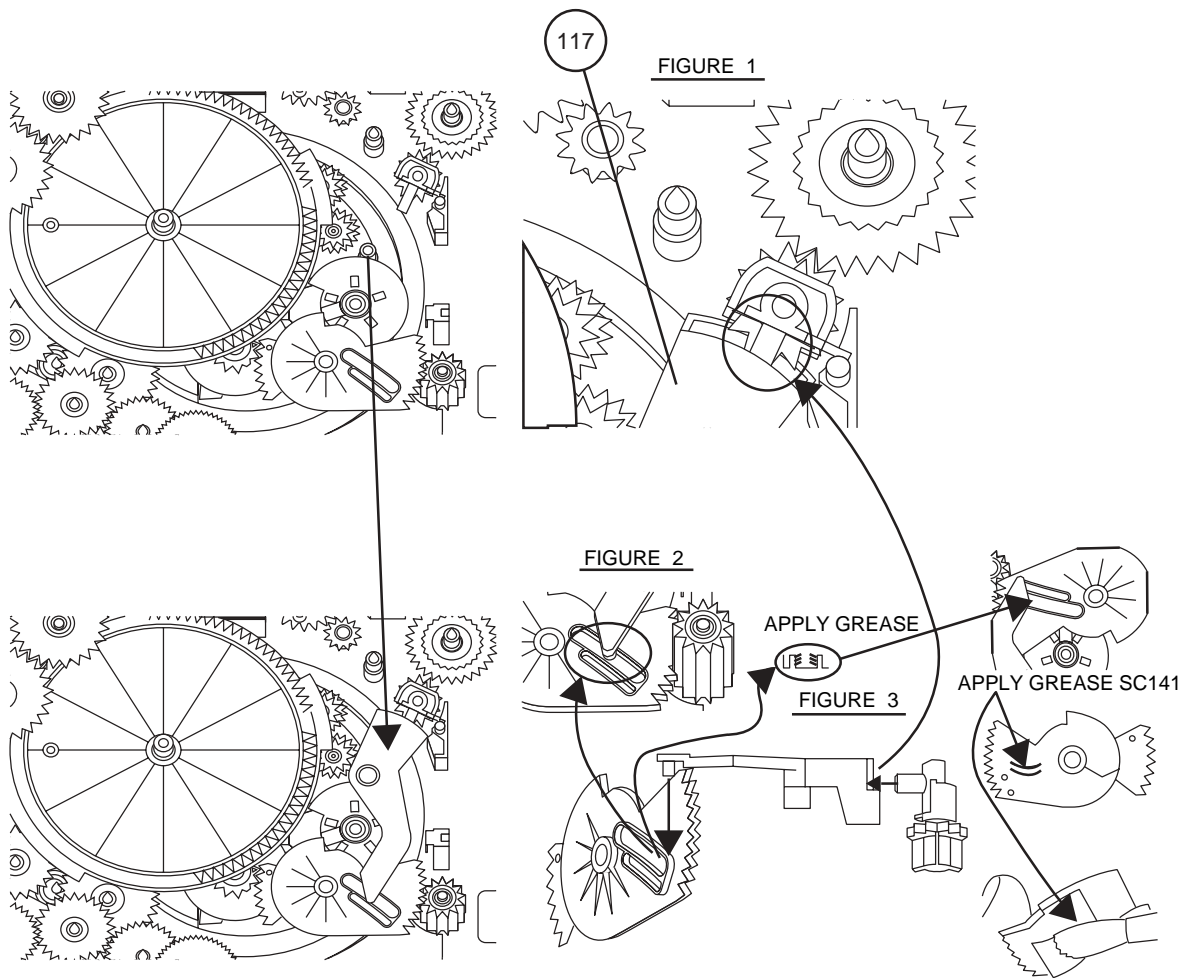

13

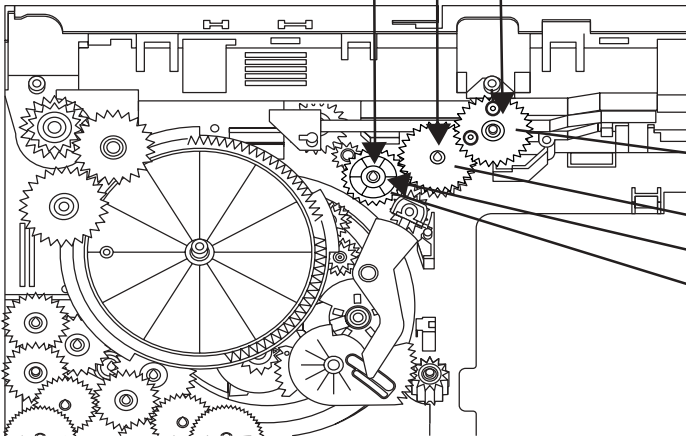
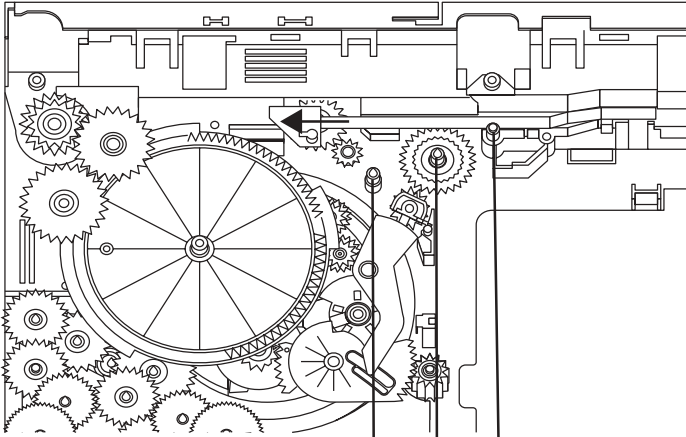

ITEM 2, 3 MUST APPLY GREASE ON TOP SIDE GEAR ONLY

134

133

132

GEAR 112
O . K

GEAR 112
N . G

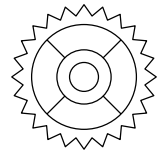
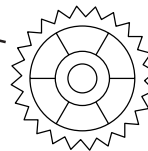

TOP VIEW AFTER
ASSY

FIX REVERSE N.G

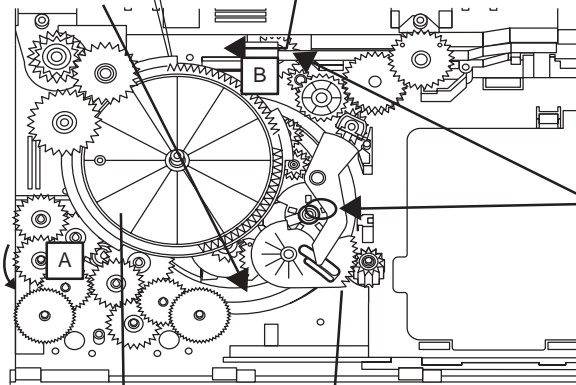
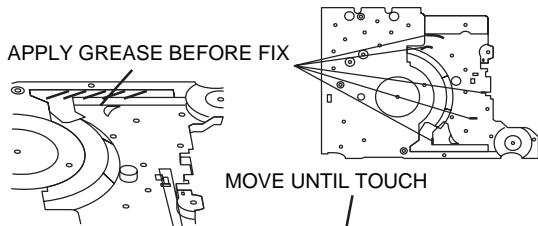

DURING GEAR A ROTATE
MUST PRESS SHOWN AREA
AND LEVER B WILL MOVE
ARROW DIRECTION THEN
FIX ITEM 1 .

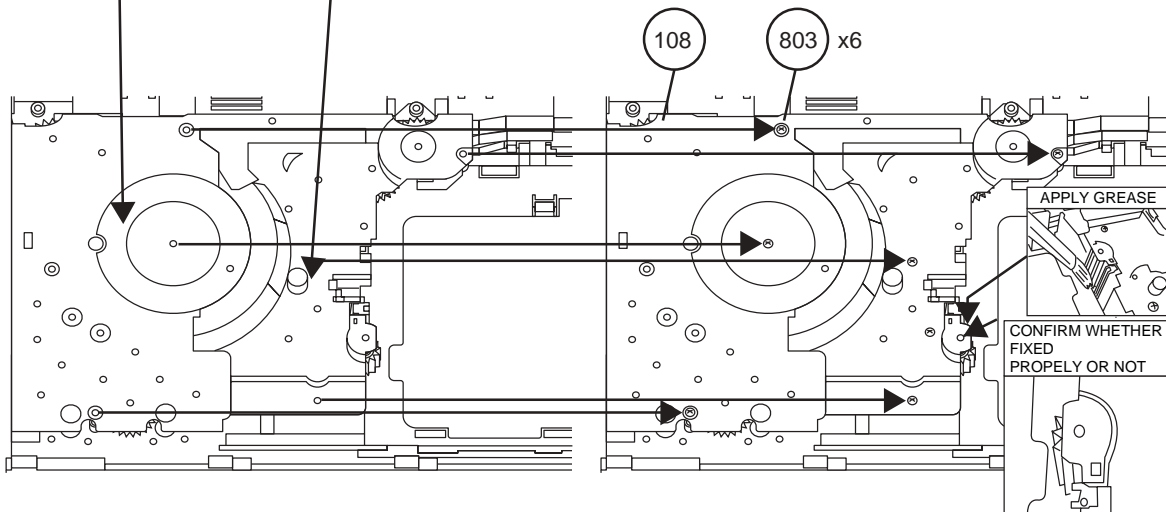

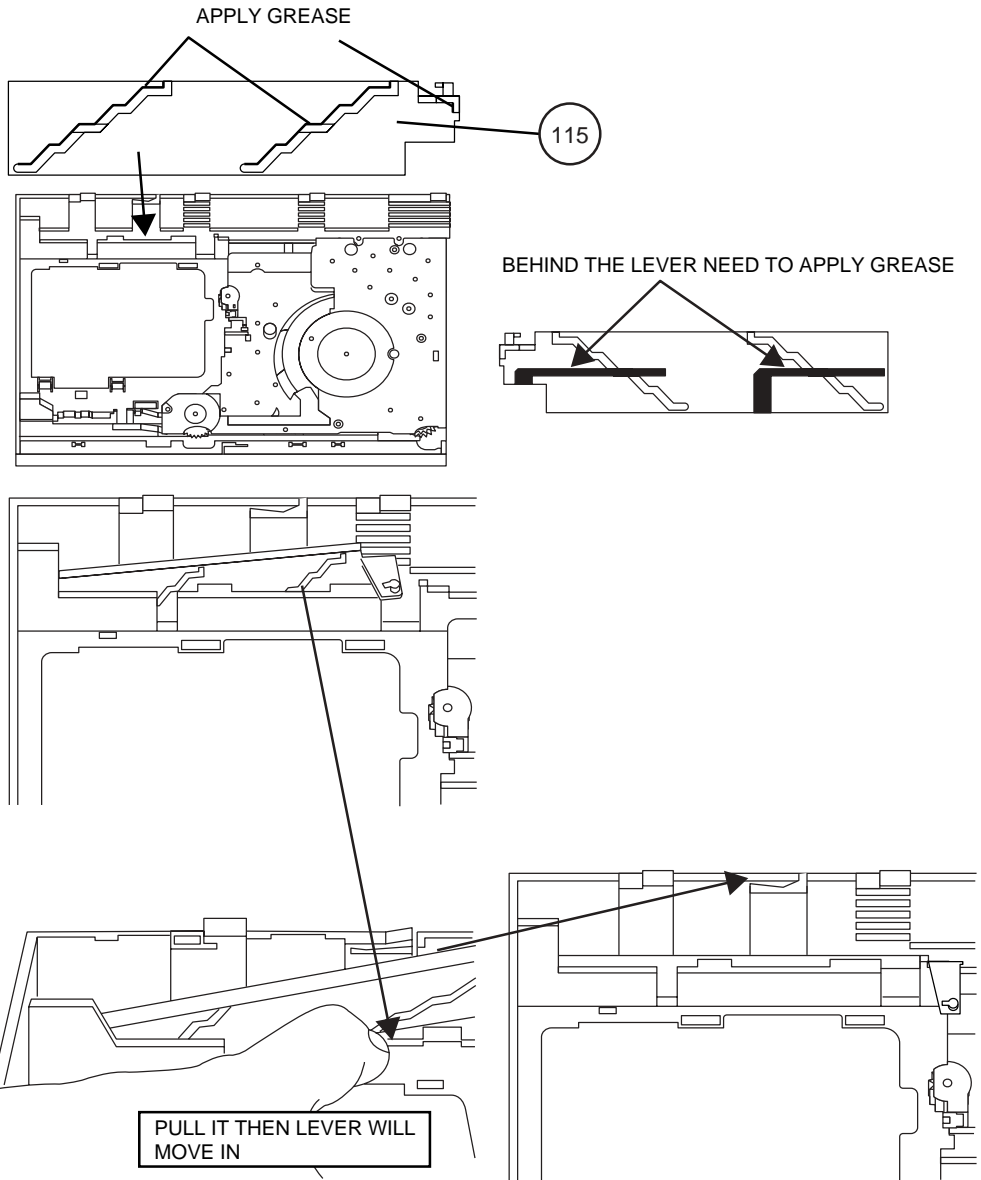

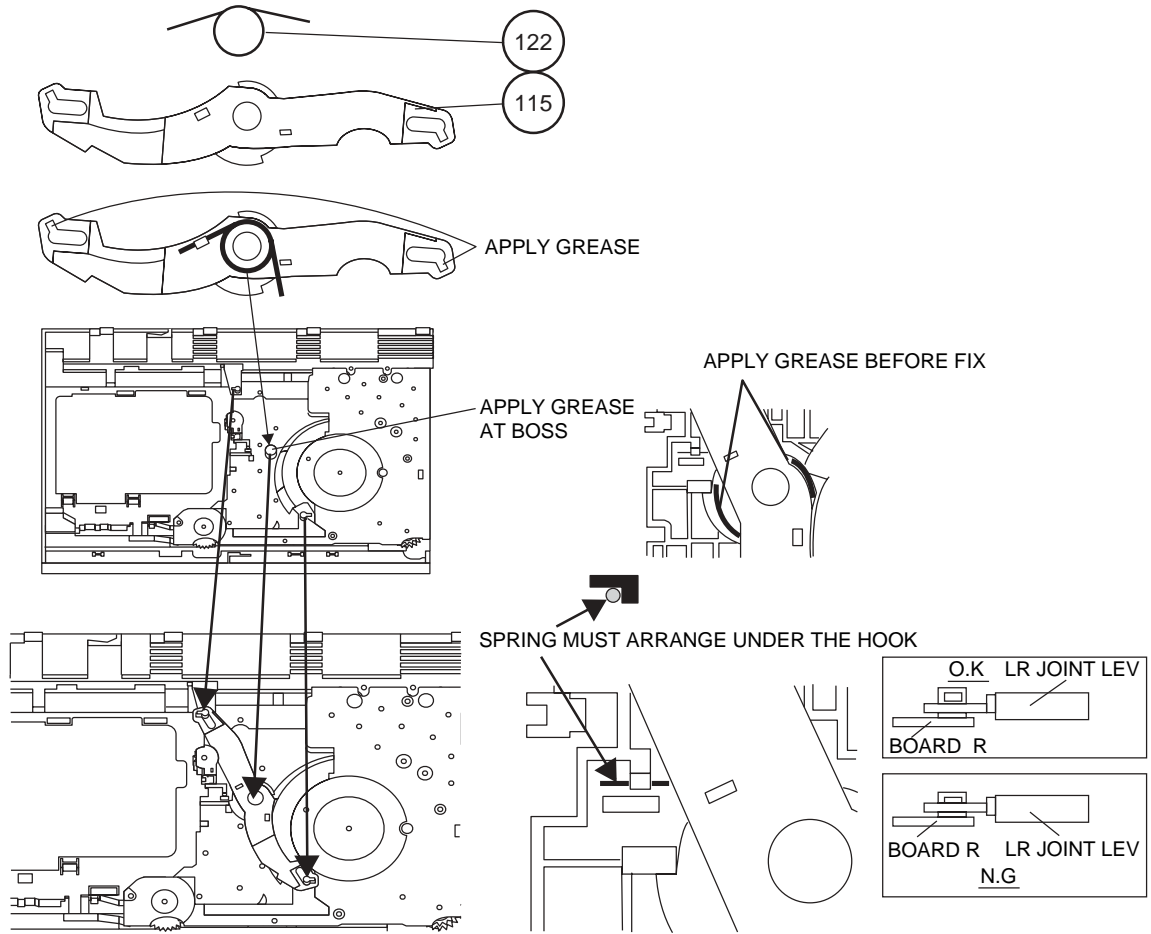

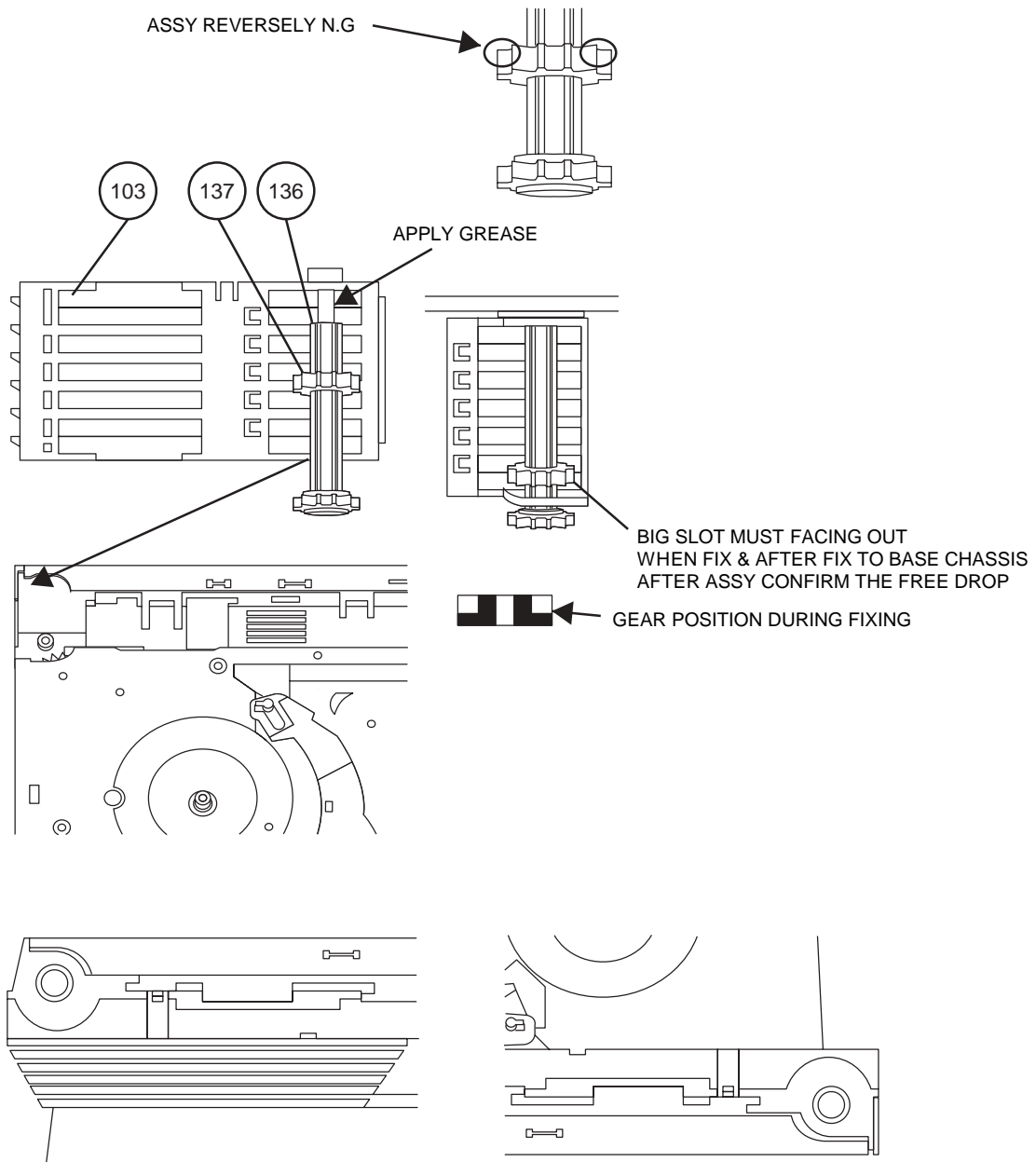

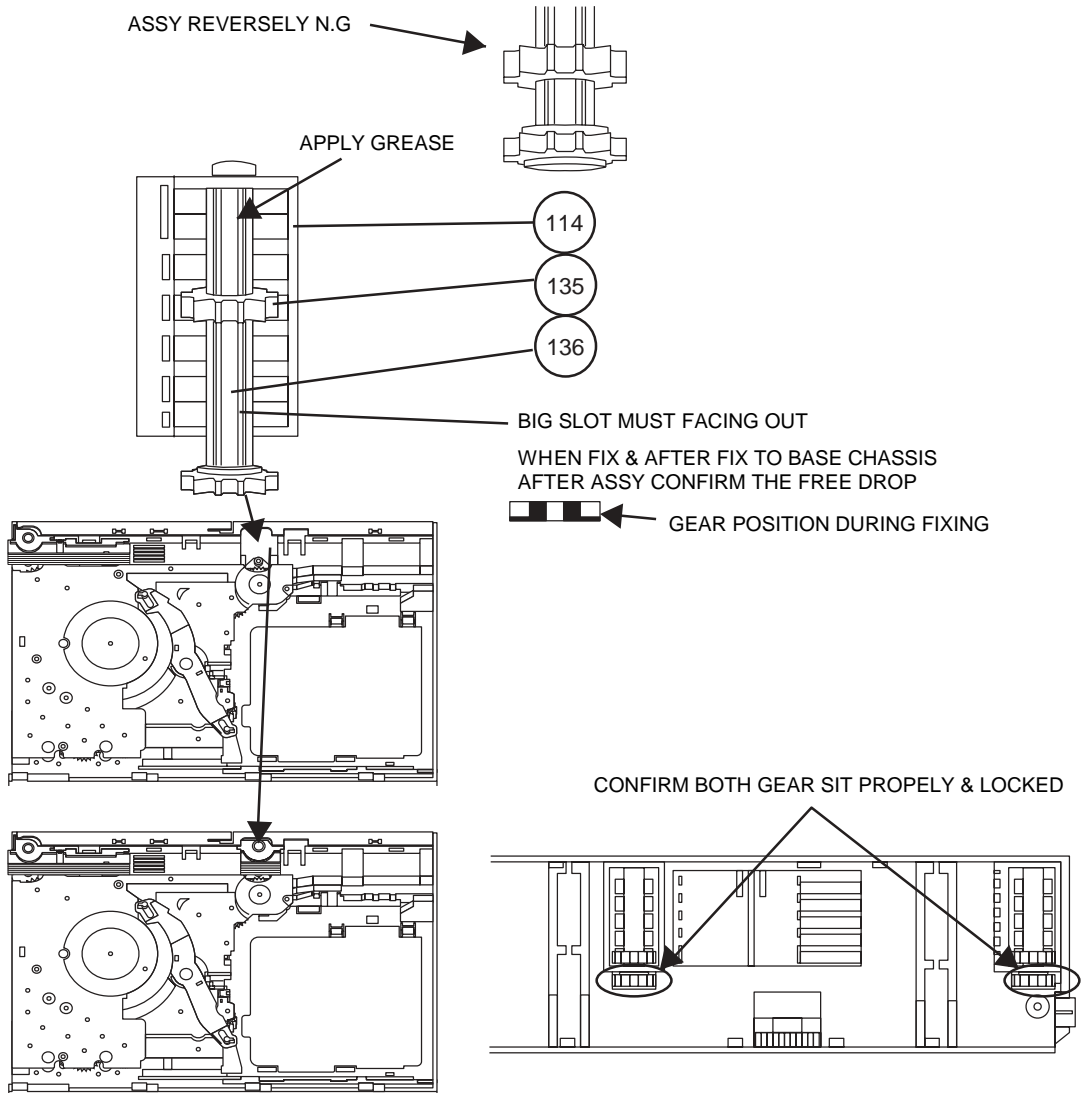

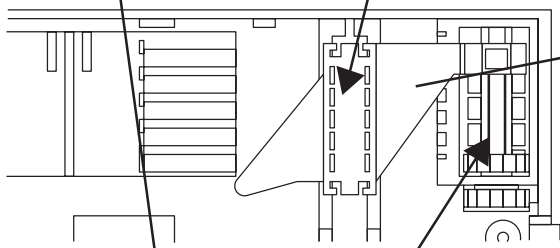
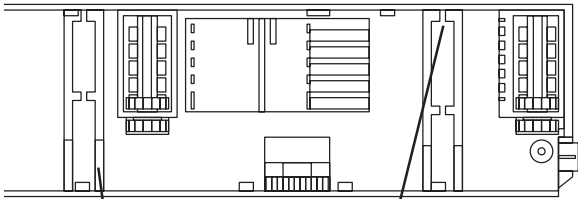

BIGGER SLOT FACING OUT

AFTER FIX OUTER UP/DOWN LEVER HOLD SHOWN PORTION AND MOVE UP/DOWN THAN CONFIRM LEVER GO INSIDE THE HOLE OR NOT

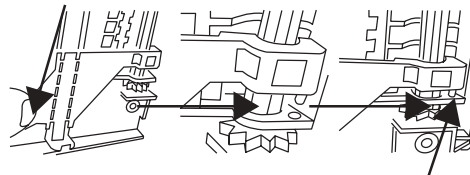

IF GO INSIDE HOLE IS O.K

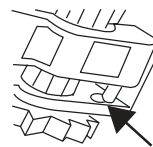

IF NO GO INSIDE HOLE IS N.G

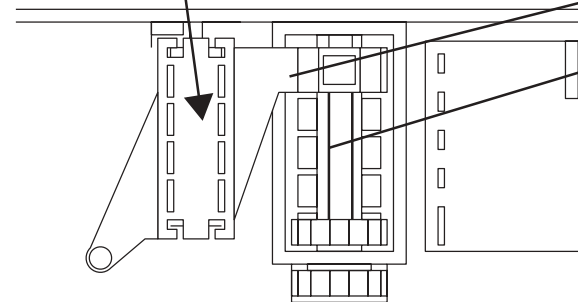

BIGGER SLOT FACING OUT

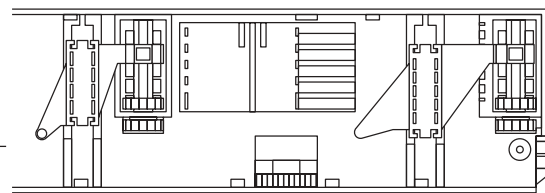

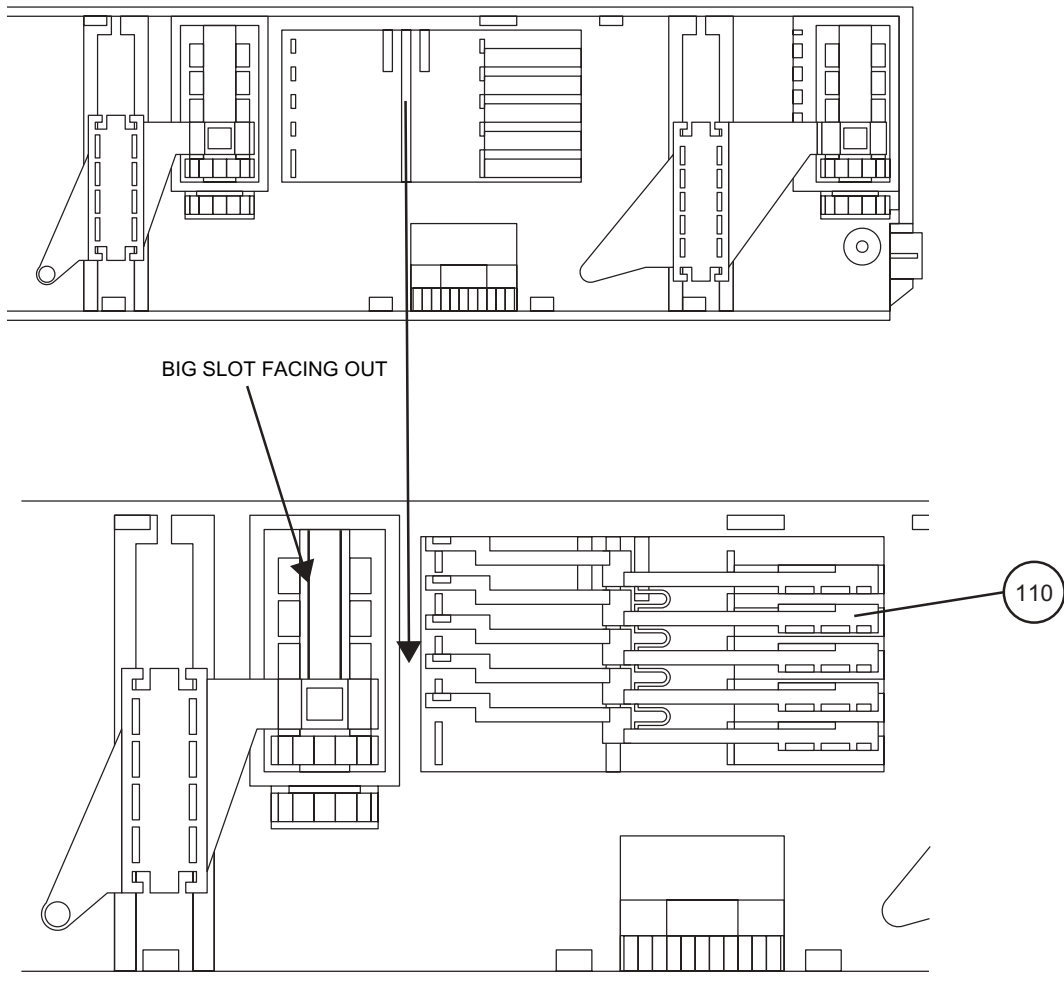

21

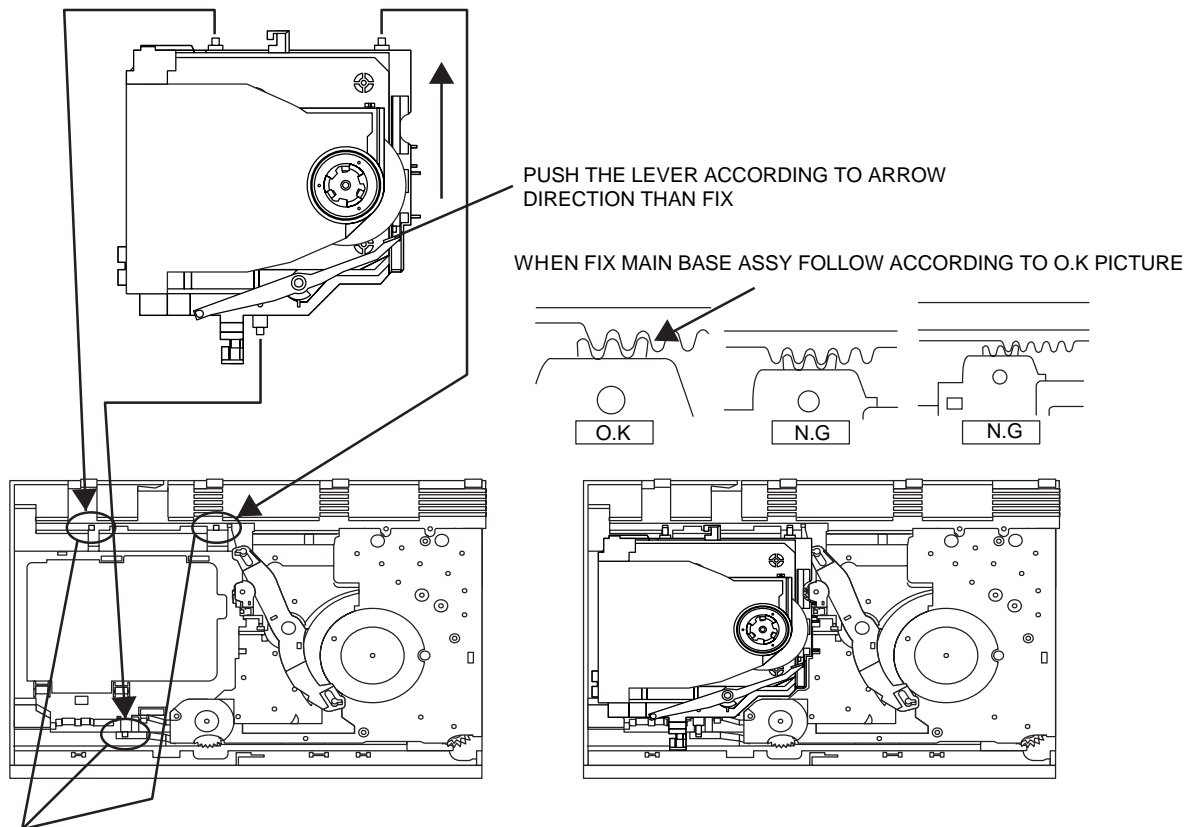

MAKE SURE MECHA HOLDER SHAFT FIX PROPELY TO LEVER

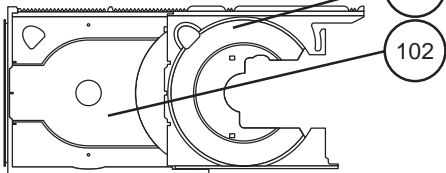
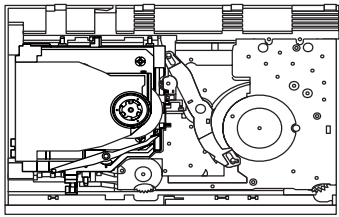
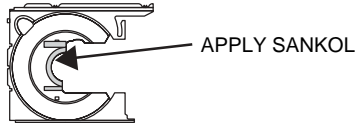

APPLY SANKOL ON TOP

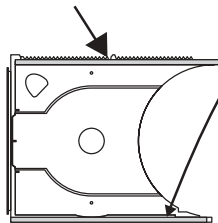

APPLY SANKOL INSIDE THE SLOT & OTHER SHOWN PORTION

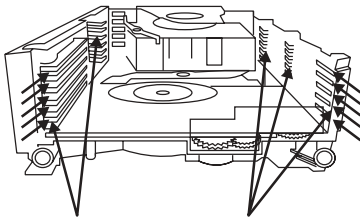
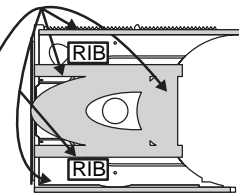

APPLY SANKOL AT TRAY SLIDING PORTION

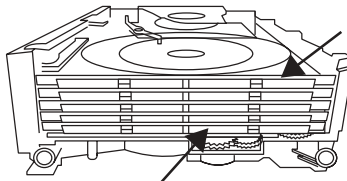

FIX TRAY NO 1 FIRST THAN FOLLOW OTHER

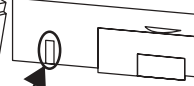

COSMO GUIDE TRAY HAVE MARKING AS SHOWN

23

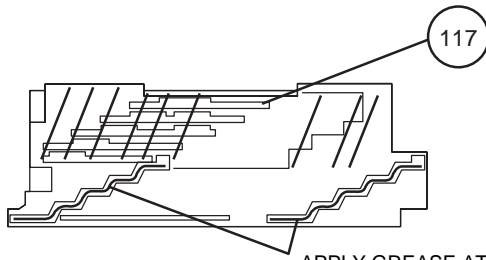

APPLY GREASE AT INNER & OUTER GEAR SLIDING PORTION

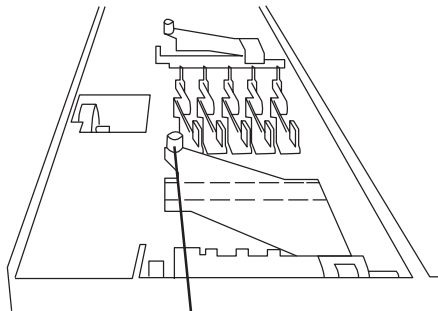

WHEN FIX GEAR UP/
DOWN BOARD THE
TWO LEVER MUST AT
PARALLEL LINE &
POSITION AT TOP
MAX SIDE

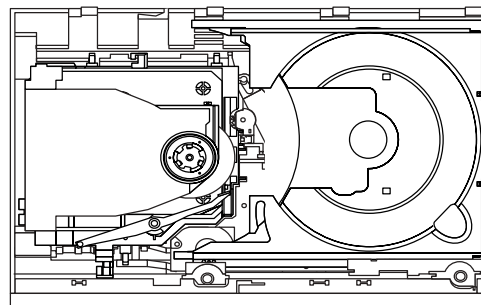
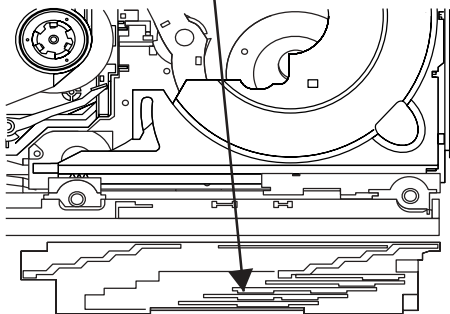
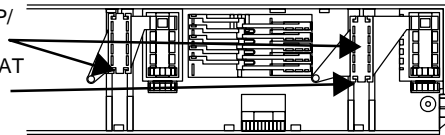

AFTER ASSY GEAR UP/DOWN BOARD

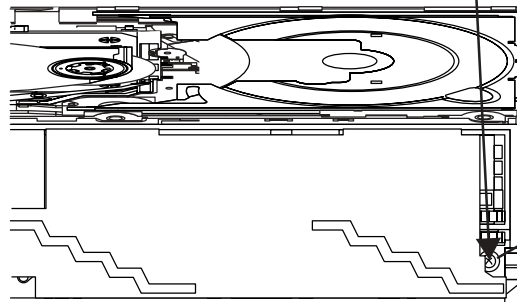
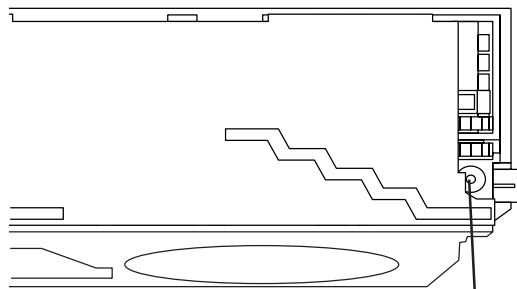
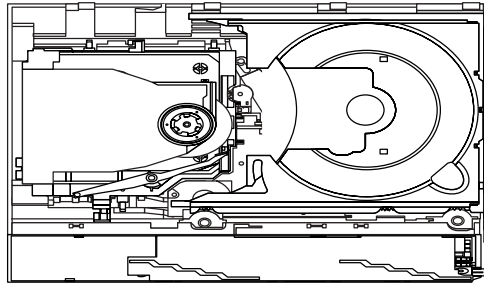

804

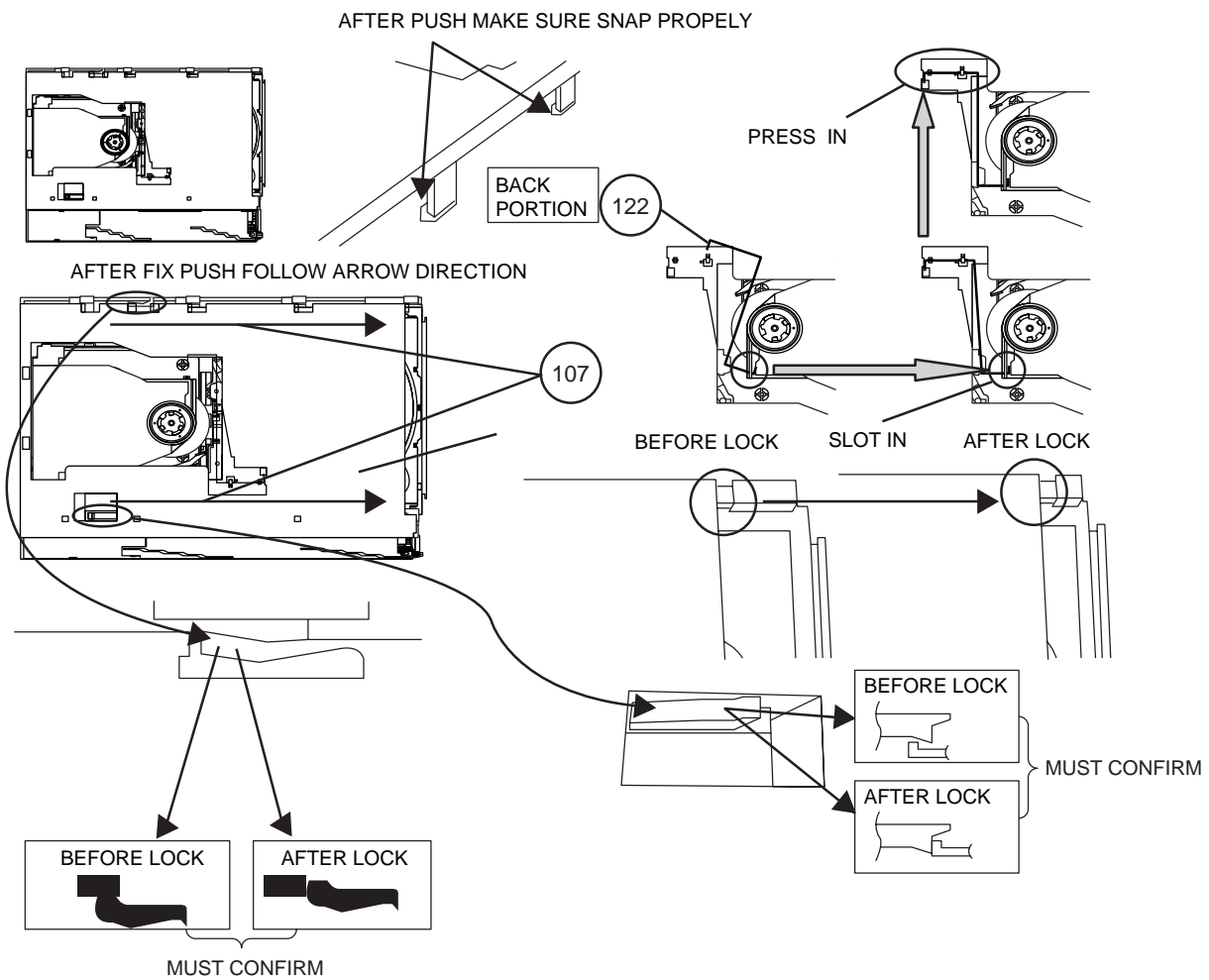
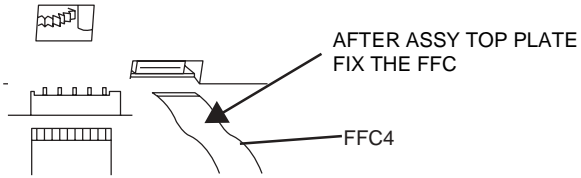

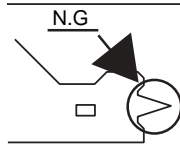
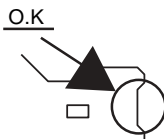
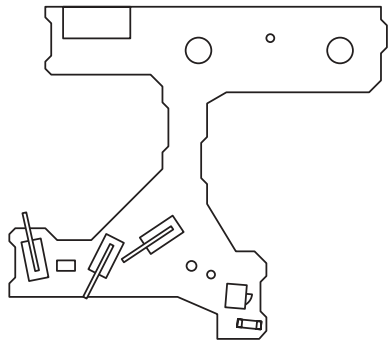

CAUTION

1. MAKE SURE NO PWB CHIP INSIDE SET . (BEFORE FIX MAKE SURE PWB NO DUST , GREASE & ETC)

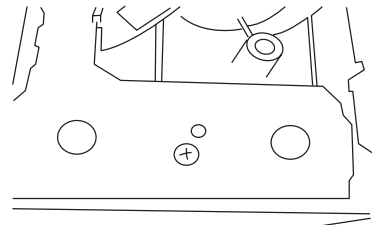
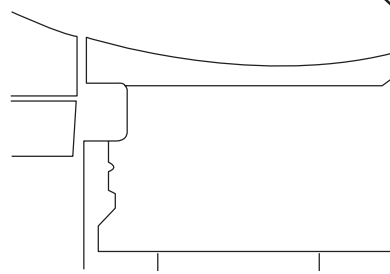
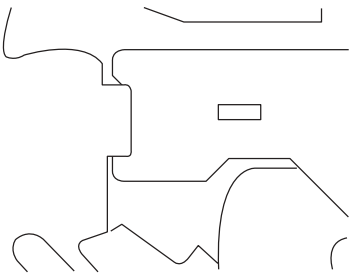
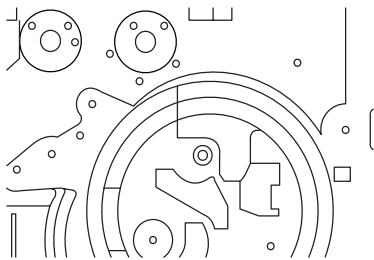

803

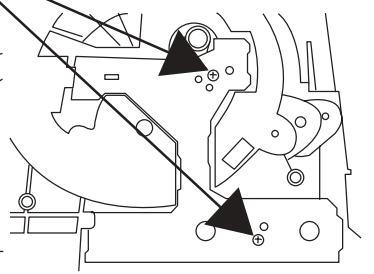

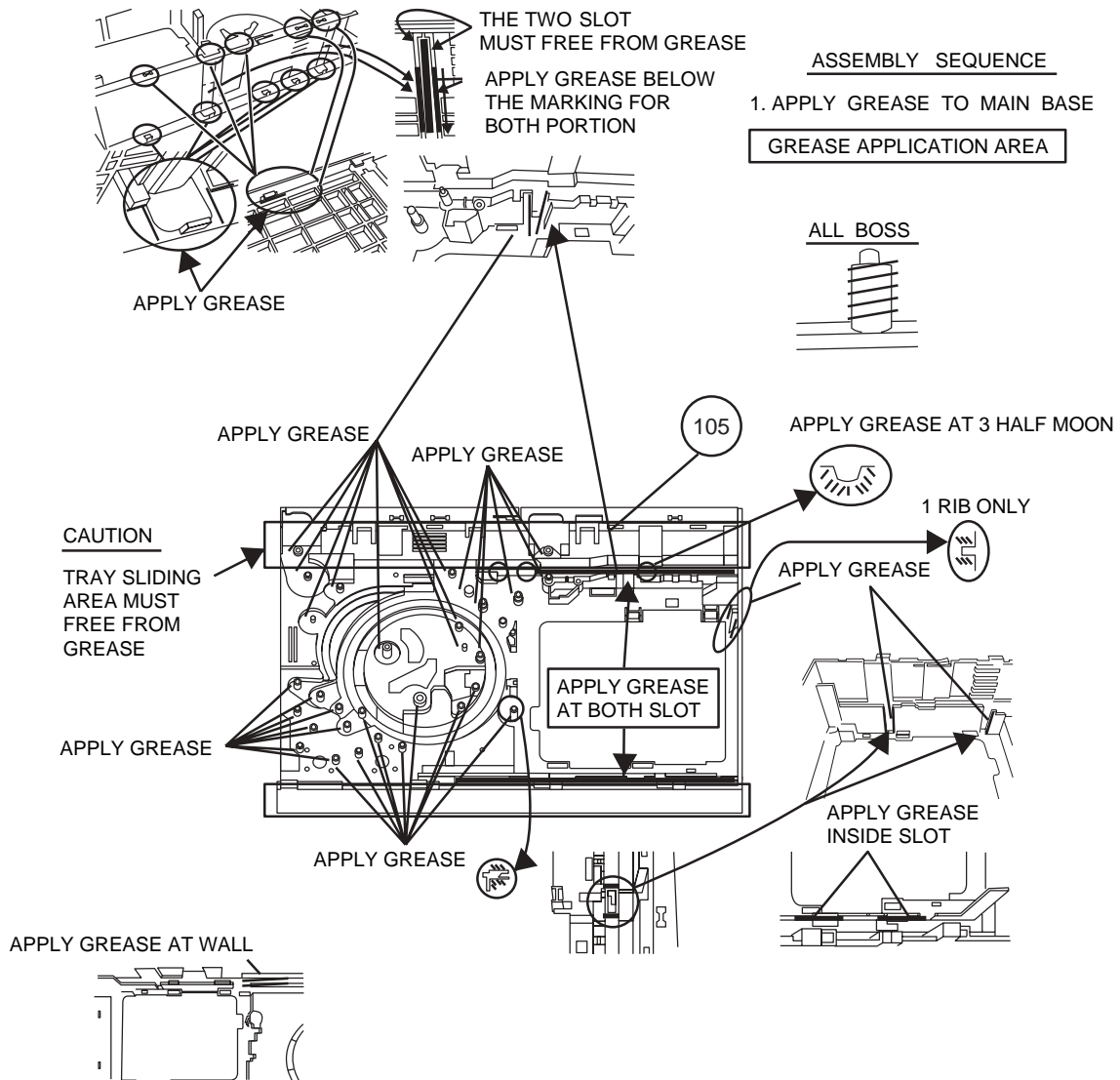

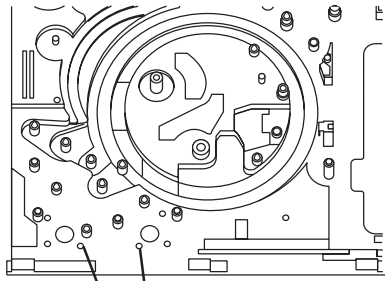

REFERENCE ONLY
MOTOR GEAR HEIGHT FROM
MAIN BASE $12.2 + 0.1$

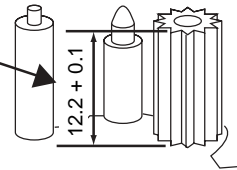

MOTOR SCREWING HOLE

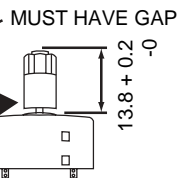
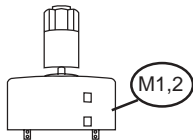

SCREW TORQUE	
1.5	+ 0.5
	- 0

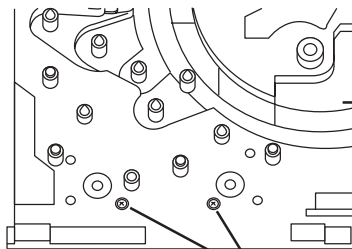

801

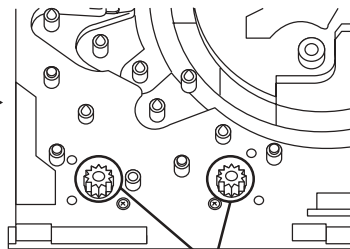

APPLY GREASE

AFTER SCREW MOTOR, CONFIRM THE
ARRANGEMENT AS IN FIGURE 2

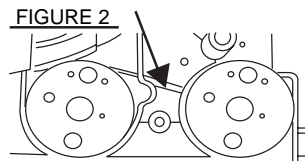

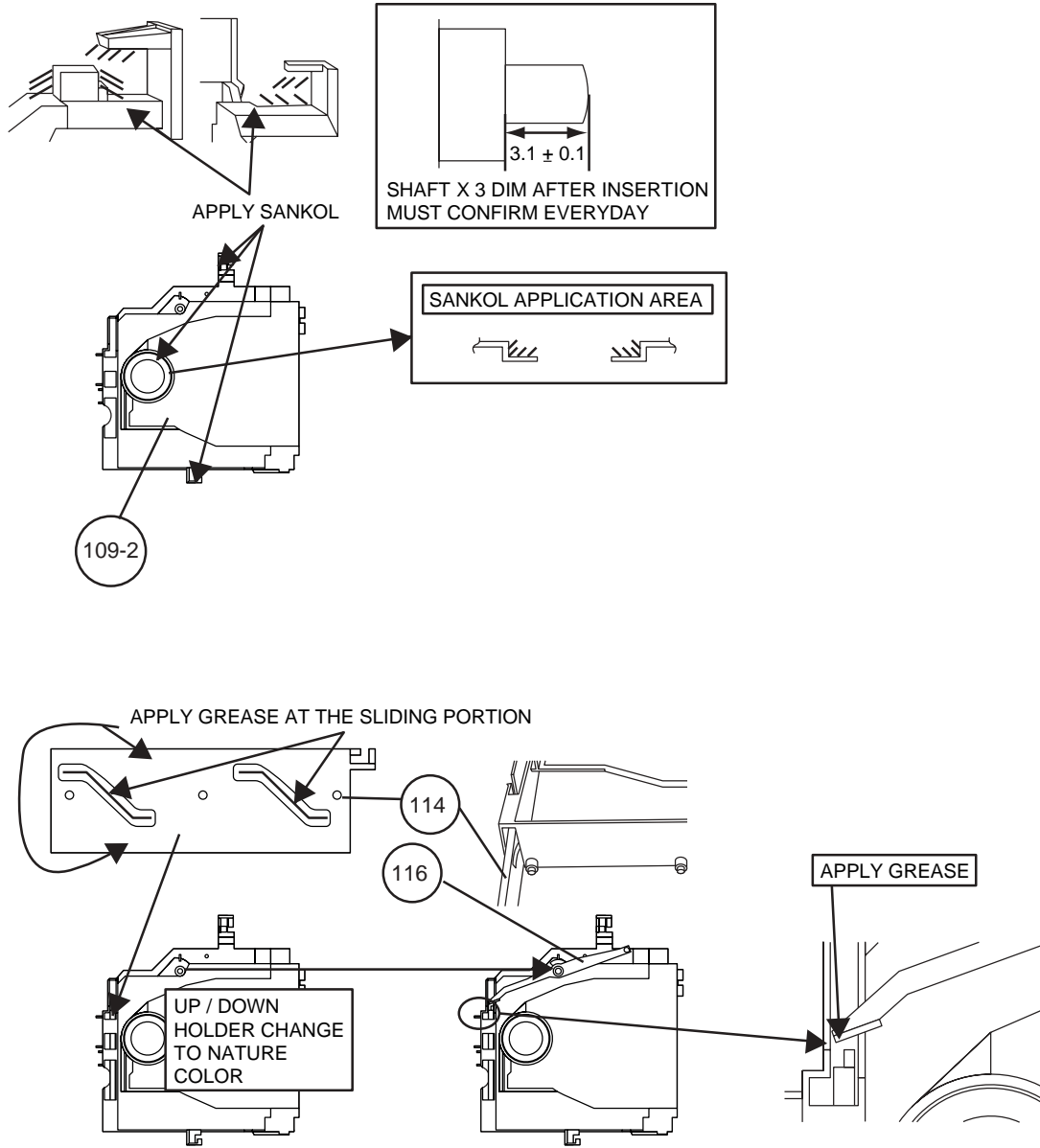

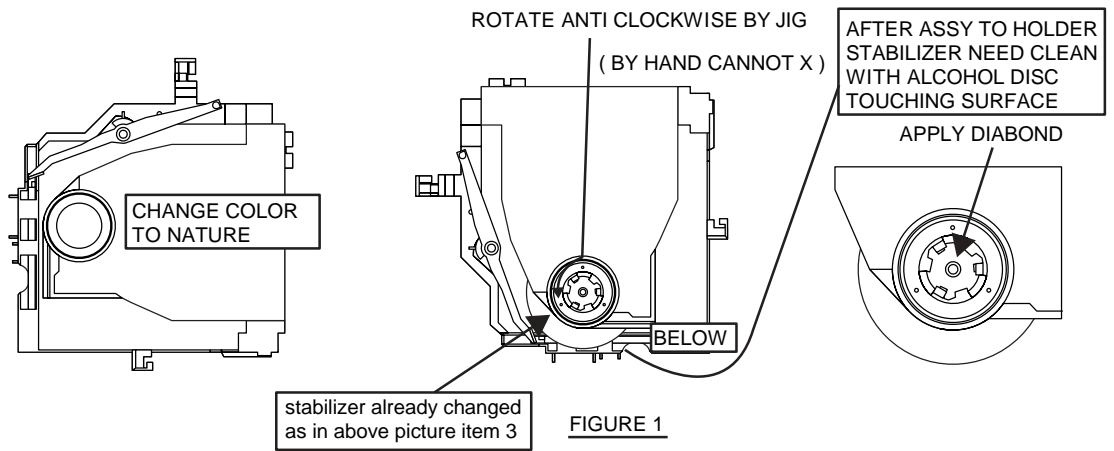
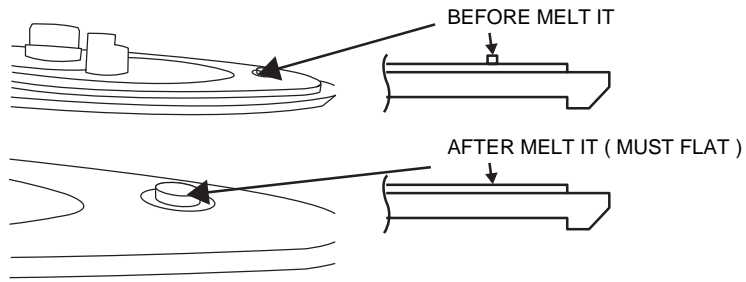

31

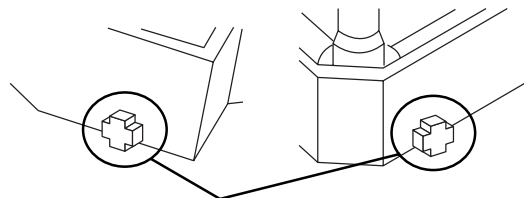
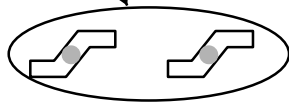
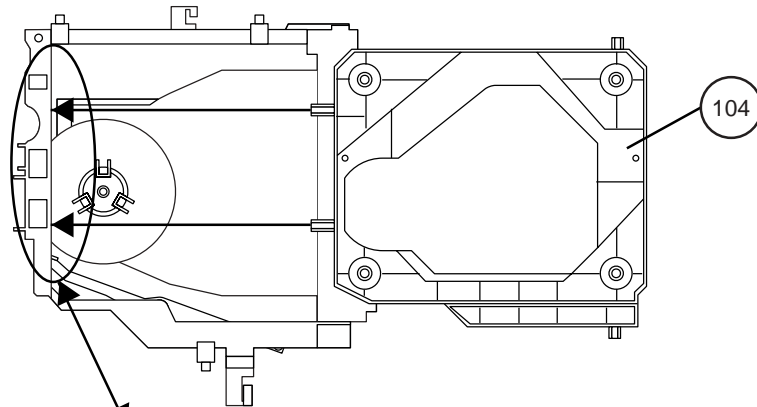

APPLY GREASE

MUST MAKE SURE SNAP PROPELY BOTH SIDE

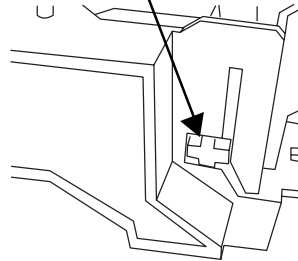
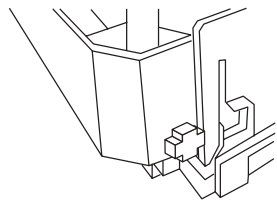
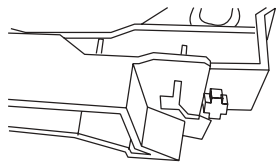

ALL SURFACE MUST TOUCH

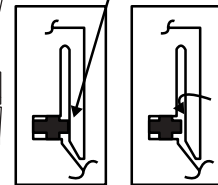

O.K

N.G

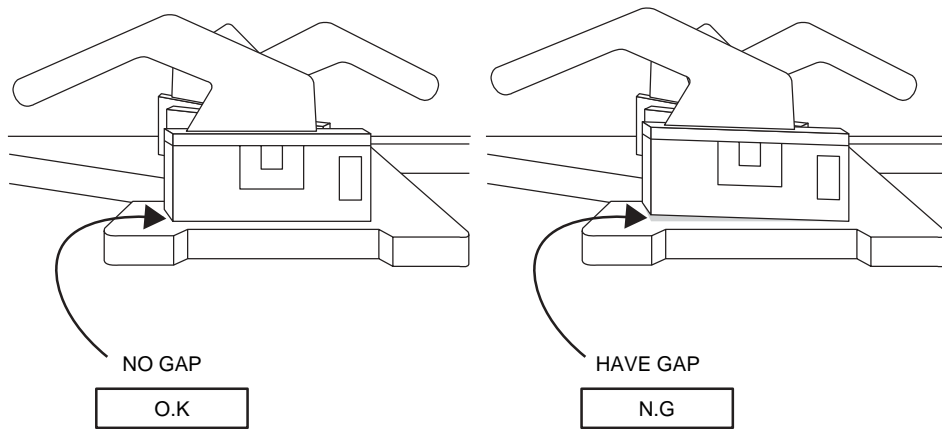

CHAPTER 3. MECHANISM BLOCKS

[1] Caution on disassembly

Caution on Disassembly

Follow the below-mentioned notes when disassembling the unit and reassembling it, to keep it safe and ensure excellent performance:

1. Take cassette tape and compact disc out of the unit.
2. Be sure to remove the power supply plug from the wall outlet before starting to disassemble the unit.
3. Take off nylon bands or wire holders where they need to be removed when disassembling the unit. After servicing the unit, be sure to rearrange the leads where they were before disassembling.

CD-ES900/CD-ES99		
STEP	REMOVAL	PROCEDURE
1	Top/Side Cabinet	1. Screw (A1) x11
2	Rear Panel, B/ Changer Mechanism Unit	1. Screw (B1) x2 2. Hook (B2) x2 3. Flat Cable (B3) x1 4. Socket (B4) x1
3	Rear Panel, A with Fan Motor	1. Screw (C1) x6 2. Socket (C2) x1
4	Main PWB	1. Screw (D1) x2 2. Flat Cable (D2) x1 3. Socket (D3) x4 4. Flat Wire (D4) x1 5. Screw (D5) x4
5	Front Panel	1. Screw (E1) x2 2. Flat Wire (E2) x1 3. Hook (E3) x2
6	Tape Mechanism	1. Open the cassette holder. 2. Screw (F1) x6 3. Flat Cable (F2) x1
7	Display PWB	1. Knob (G1) x1 2. Screw (G2) x10 3. Hook (G3) x5
8	Game Input PWB	1. Screw..... (H1) x2
9	CD Servo PWB	1. Screw (J1) x3 2. Flat Cable (J2) x2 3. Socket (J3) x1 4. Hook (J4) x1
10	Changer Mechanism Unit	1. Screw (K1) x4 2. Changer Chassis (K2) x1
11	CD Mechanism	1. Screw (L1) x4

Note 1:
After removing the connector for the optical pickup from the connector, wrap the conductive aluminium foil around the front end of the connector so as to protect the optical pickup from electrostatic damage.

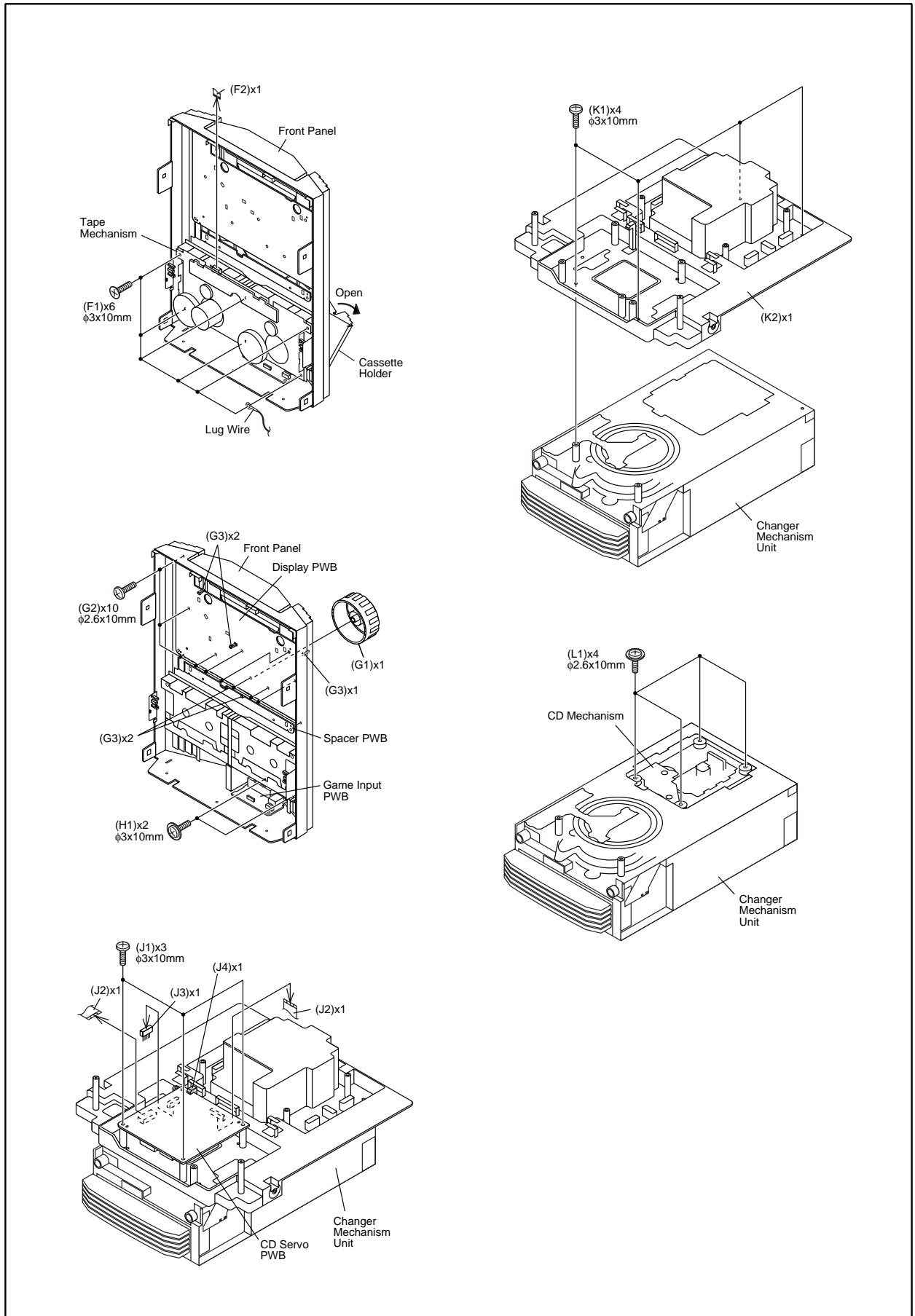

CP-ES900/CP-ES99

STEP	REMOVAL	PROCEDURE
1	Passive Radiator	1. Screw (A1) x4 2. Side Panel (A2) x1 3. Screw (A3) x4
2	Woofer	1. Front Panel (B1) x1 2. Screw (B2) x4
3	Tweeter	1. Screw (C1) x2
4	Super Tweeter	1. Screw (D1) x4

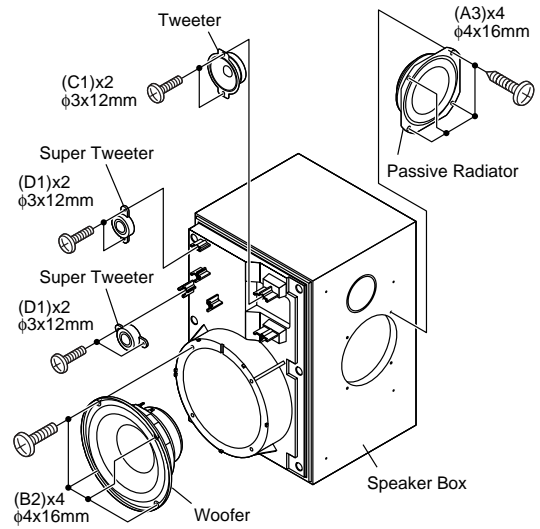
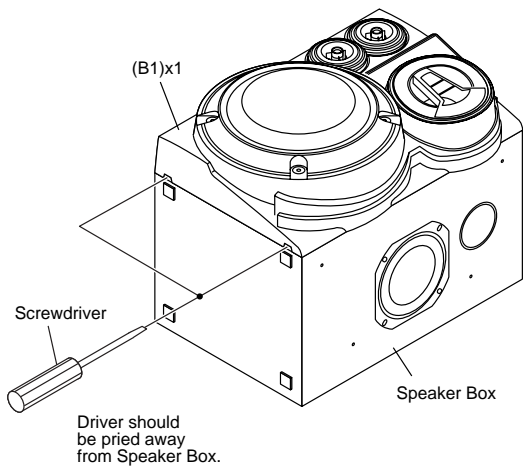
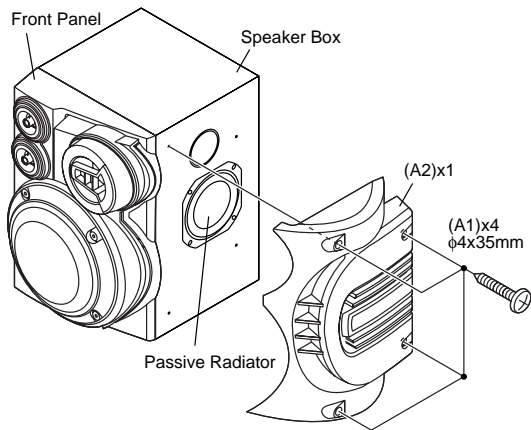

[2] Removing and reinstalling the main parts

1. TAPE MECHANISM SECTION

Perform steps 1 to 5 and 6 of the disassembly method to remove the tape mechanism.

1.1. How to remove the record/playback and erase heads (TAPE 2) (See Fig. 1)

1. When you remove the screws (A1) x 2 pcs., the recording/playback head and three-dimensional head of the erasing head can be removed.

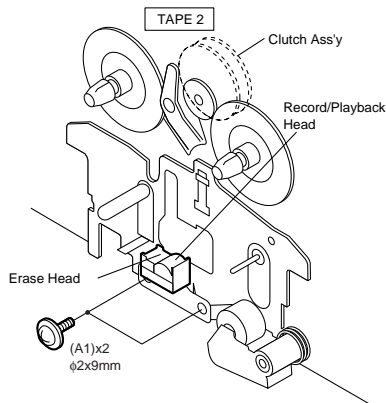

Figure 1

1.2. How to remove the playback head (TAPE 1) (See Fig. 2)

1. When you remove the screws (B1) x 2 pcs., the playback head can be removed.

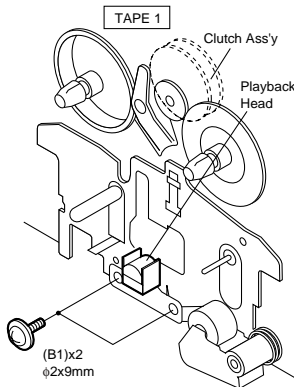

Figure 2

1.3. How to remove the pinch roller (TAPE 1/2) (See Fig. 3)

1. Carefully bend the pinch roller pawl in the direction of the arrow <A>, and remove the pinch roller (C1) x 1 pc., in the direction of the arrow .

NOTE: When installing the pinch roller, pay attention to the spring mounting position.

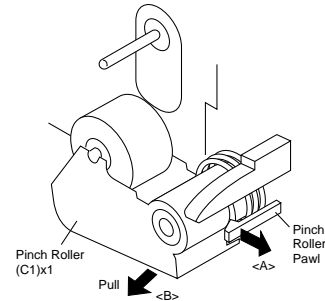

Figure 3

1.4. How to remove the belt (TAPE 2) (See Fig. 4)

1. Remove the main belt (D1) x 1 pc., from the motor side.
2. Remove the FF/REW belt (D2) x 1 pc.

1.5. How to remove the belt (TAPE 1) (See Fig. 4)

1. Remove the main belt (E1) x 1 pc., from the motor side.
2. Remove the FF/REW belt (E2) x 1 pc.

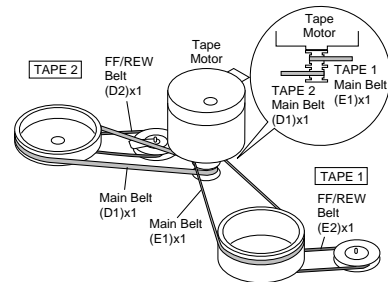

Figure 4

1.6. How to remove the motor. (See Fig. 5)

1. Remove the screws (F1) x 2 pcs., to remove the motor.

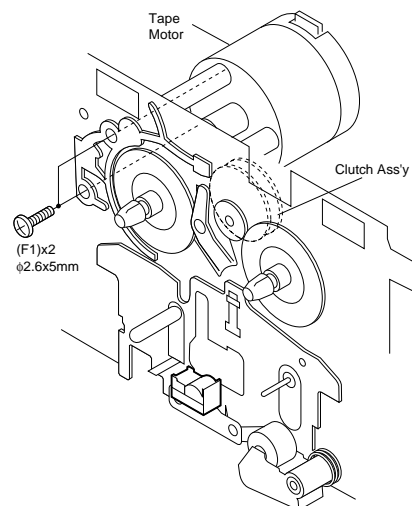

Figure 5

2. CD MECHANISM SECTION

Perform steps 1, 2, 9, 10 and 11 of the disassembly method to remove the CD mechanism.

2.1. Remove the pickup. (See Fig. 1)

1. Remove the stop washer (A1) x 1 pc., to remove the gear (A2) x 1 pc.
2. Remove the screws (A3) x 2 pcs., to remove the shaft (A4) x 1 pc.
3. Remove the pickup.

NOTE: After removing the connector for the optical pickup from the connector wrap the conductive aluminium foil around the front end of connector so as to protect the optical pickup from electrostatic damage.

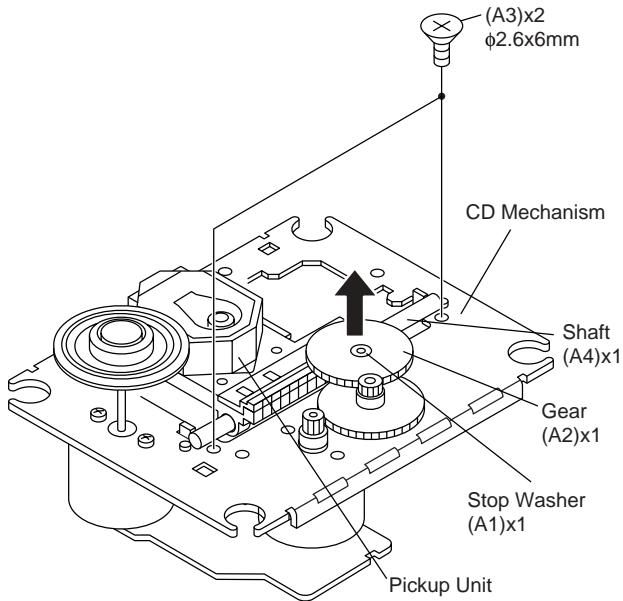

Figure 1

3. CHANGER MECHANISM SECTION

Perform steps 1, 2, 9, 10 and 11 of the disassembly method to remove the CD changer mechanism.

3.1. How to remove CD Disc. (See Fig. 2~5)

1. When CD is at play position, Rotate reduction gear C clock-wise as shown in Figure 1 Until disc tray is at stalk position, then rotate further to eject the disc tray so that CD can be removed from the tray.
2. In another case, if CD mechanism is at tray No. 1 play position and to remove CD located in tray No3, the procedure is as follows:

If the gear up down board is located at tray No. 1 position, then rotate gear clock-wise until is at stalk position. Rotate reduction gear D (Figure 2) to move the CD mechanism to tray No. 3 position.

This is confirmed by checking the gear up down board position by the marking as indicated on the main chassis as shown in Figure 3.

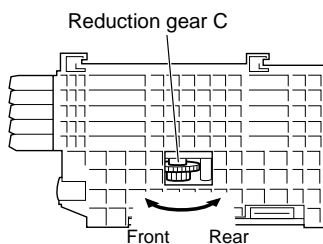

Figure 2

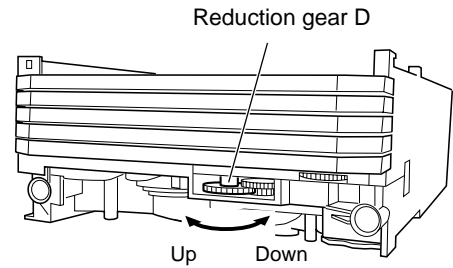

Figure 3

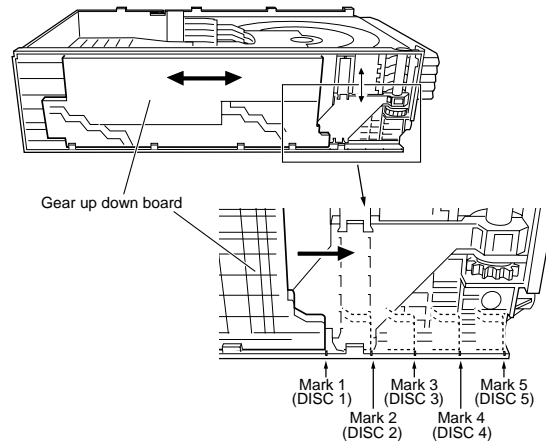
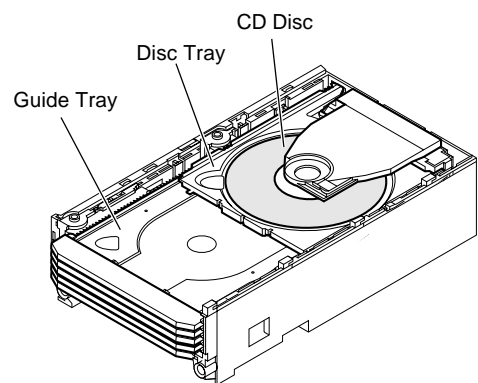
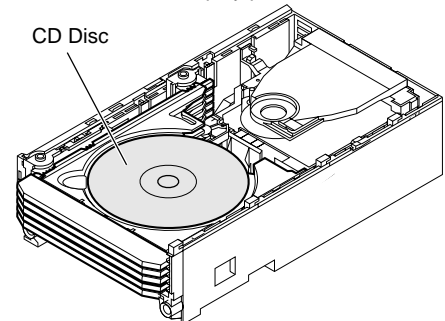

Figure 4



CD At play position.



CD At stalk position.

Figure 5

CD-ES900/CD-ES99

3.2. How to Remove the tray motor/main cam motor/5-Changer Motor PWB. (See Fig. 1)

1. Remove the screws (A1)x 2 pcs., to remove tray motor/main cam motor/5-Changer Motor PWB.

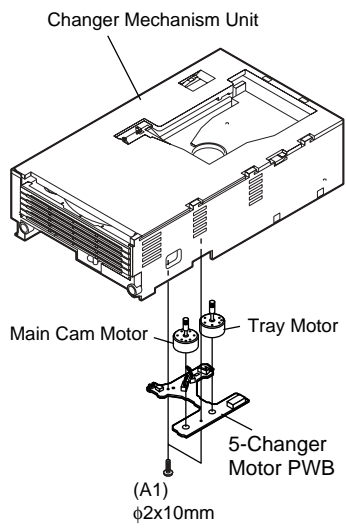

Figure 1

CHAPTER 4. DIAGRAMS

[1] Block diagram

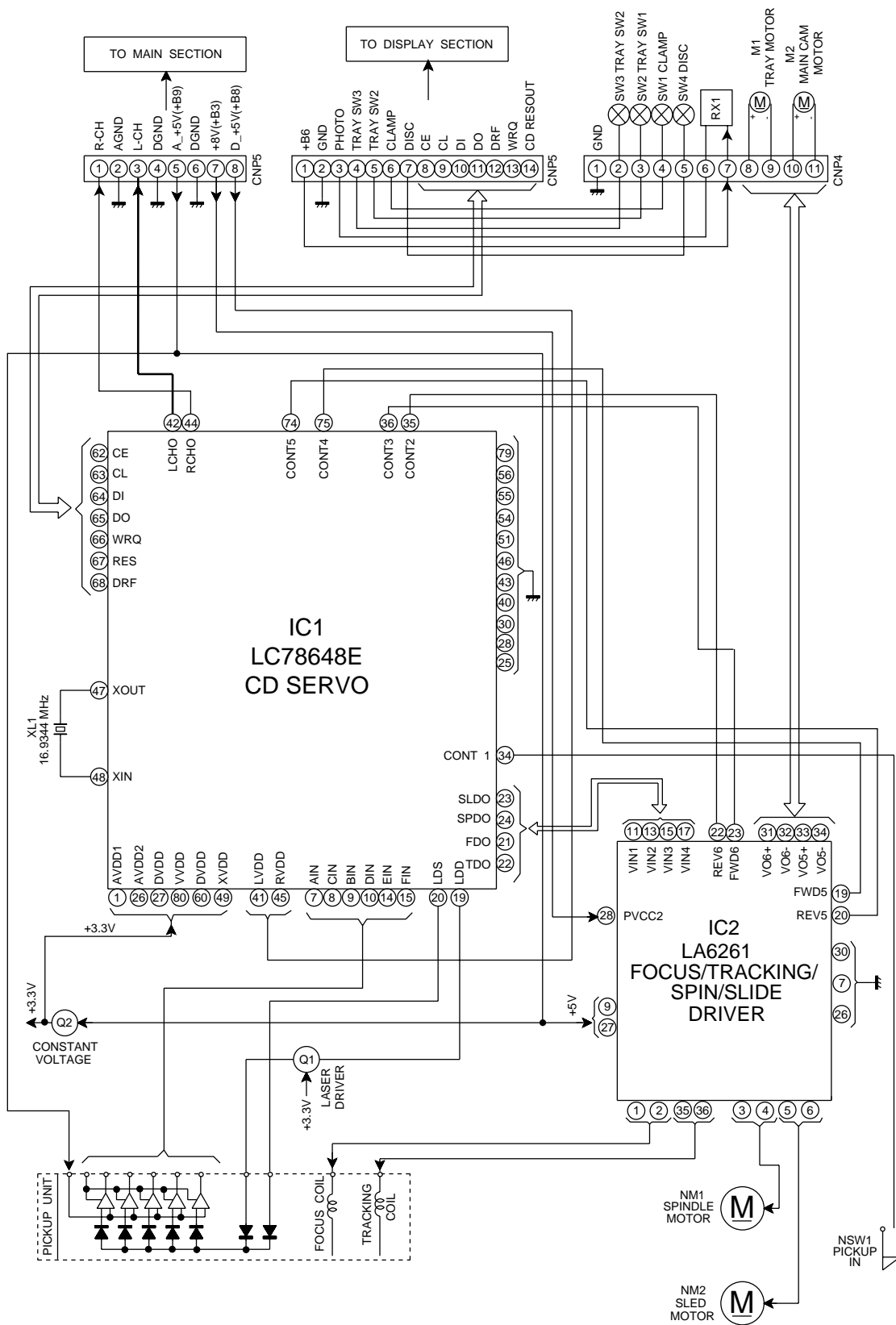

Figure 4-1 BLOCK DIAGRAM (1/3)

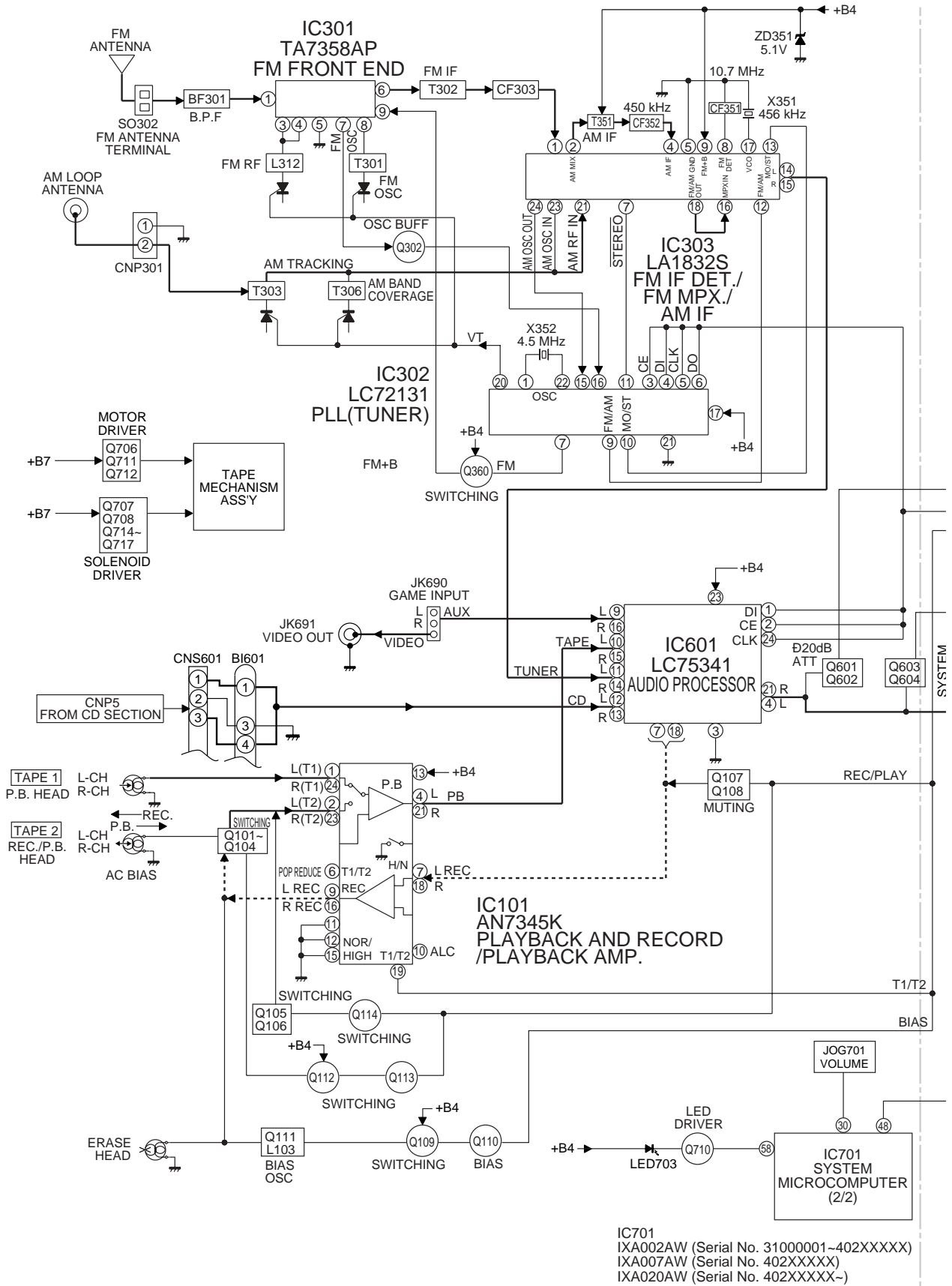

Figure 4-2 BLOCK DIAGRAM (2/3)

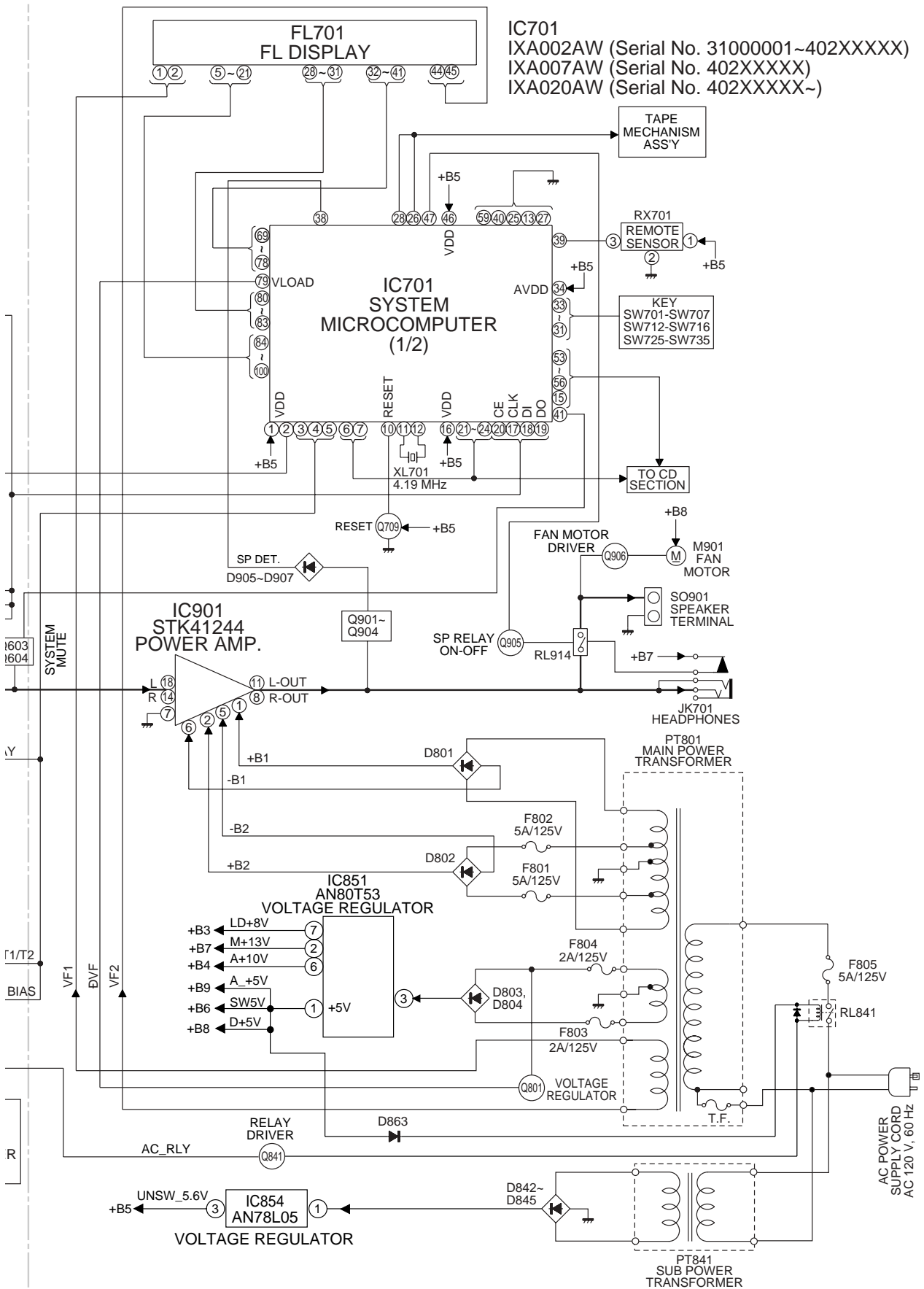



Figure 4-3 BLOCK DIAGRAM (3/3)

CHAPTER 5. CIRCUIT DESCRIPTION

[1] Notes on schematic diagram

- Resistor:
To differentiate the units of resistors, such symbol as K and M are used: the symbol K means 1000 ohm and the symbol M means 1000 kohm and the resistor without any symbol is ohm-type resistor. Besides, the one with "Fusible" is a fuse type.
- Capacitor:
To indicate the unit of capacitor, a symbol P is used: this symbol P means pico-farad and the unit of the capacitor without such a symbol is microfarad. As to electrolytic capacitor, the expression "capacitance/withstand voltage" is used.
(CH), (TH), (RH), (UJ): Temperature compensation
(ML): Mylar type
(P.P.): Polypropylene type
- Schematic diagram and Wiring Side of P.W.Board for this model are subject to change for improvement without prior notice.
- The indicated voltage in each section is the one measured by Digital Multimeter between such a section and the chassis with no signal given.
 1. In the tuner section, indicates AM indicates FM stereo
 2. In the main section, a tape is being played back.
 3. In the deck section, a tape is being played back. () indicates the record state.
 4. In the power section, a tape is being played back.
 5. In the CD section, the CD is stopped.
- Parts marked with "⚠" () are important for maintaining the safety of the set. Be sure to replace these parts with specified ones for maintaining the safety and performance of the set.

REF NO.	DESCRIPTION	POSITION
NSW1	PICKUP IN	ON-OFF
SW1	CLAMP	ON-OFF
SW2	TRAY SW1	ON-OFF
SW3	TRAY SW2	ON-OFF
SW4	DISC	ON-OFF
SW701	POWER ON/STAND-BY	ON-OFF
SW702	CLOCK/TIMER	ON-OFF
SW703	TUNING UP	ON-OFF
SW704	TUNING DOWN	ON-OFF
SW705	FAST REWIND/PRESET DOWN	ON-OFF
SW706	EQUALIZER	ON-OFF
SW707	FAST FORWARD/PRESET UP	ON-OFF
SW712	TUNER (BAND)	ON-OFF
SW713	CD	ON-OFF

REF NO.	DESCRIPTION	POSITION
SW714	TAPE	ON-OFF
SW715	GAME/VIDEO	ON-OFF
SW716	X-BASS/DEMO	ON-OFF
SW725	PLAY/REPEAT	ON-OFF
SW726	STOP	ON-OFF
SW727	REC/PAUSE	ON-OFF
SW728	MEMORY/SET	ON-OFF
SW729	OPEN/CLOSE	ON-OFF
SW730	DIRECT PLAY	ON-OFF
SW731	DISC2	ON-OFF
SW732	DISC4	ON-OFF
SW733	DISC5	ON-OFF
SW734	DISC3	ON-OFF
SW735	DISC1	ON-OFF

[2] Types of transistor and LED

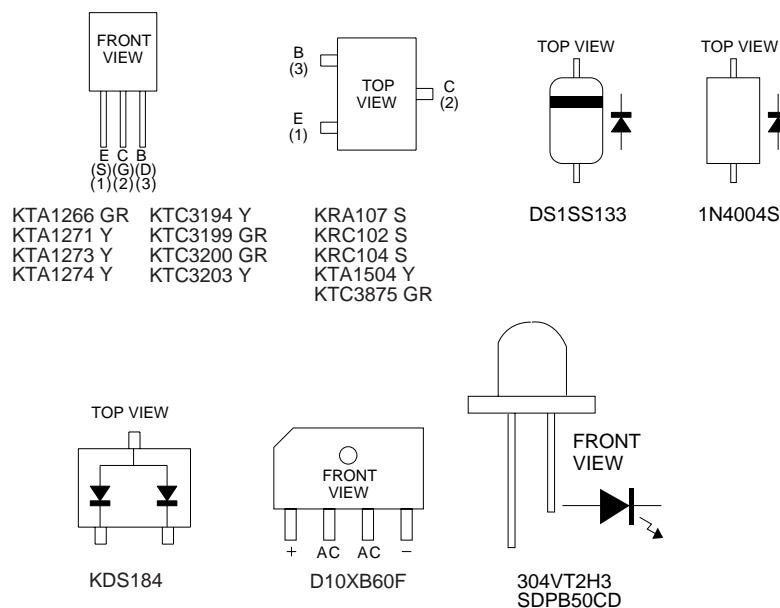

[3] Waveforms of CD circuit

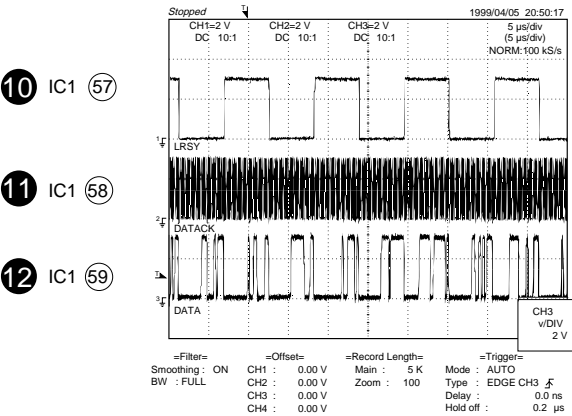
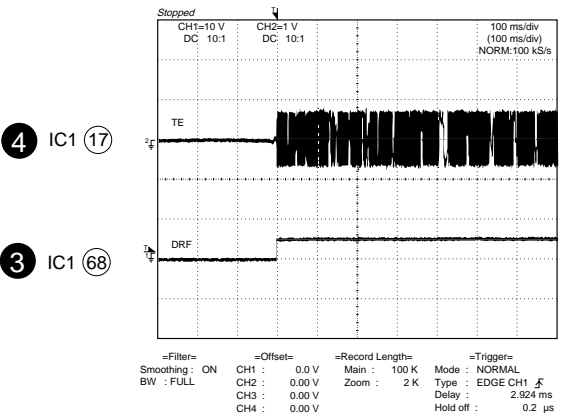
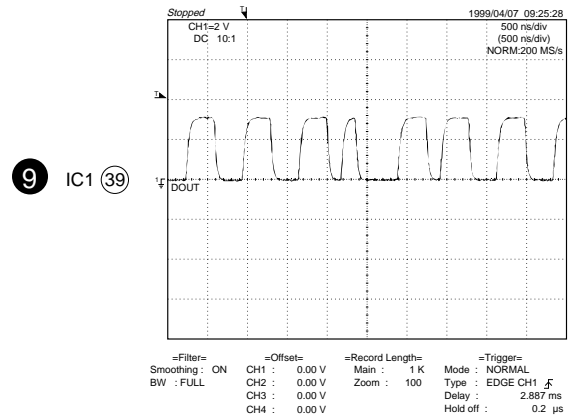
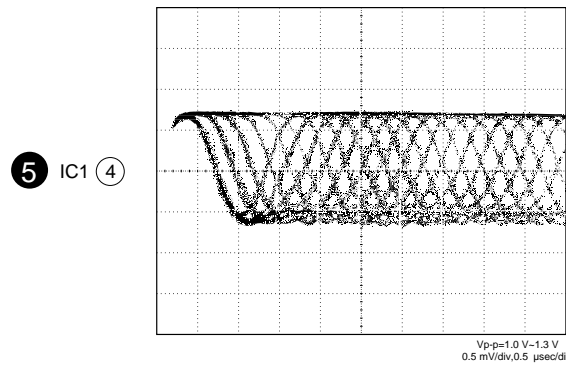
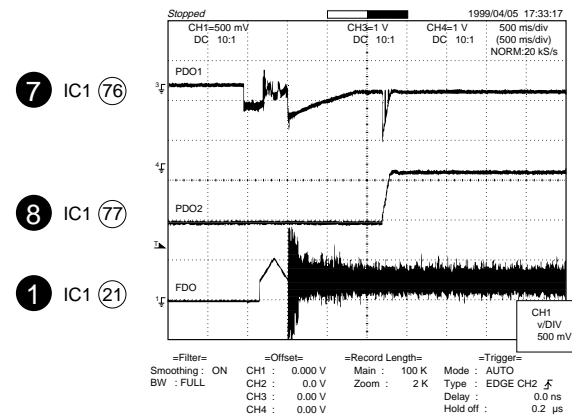
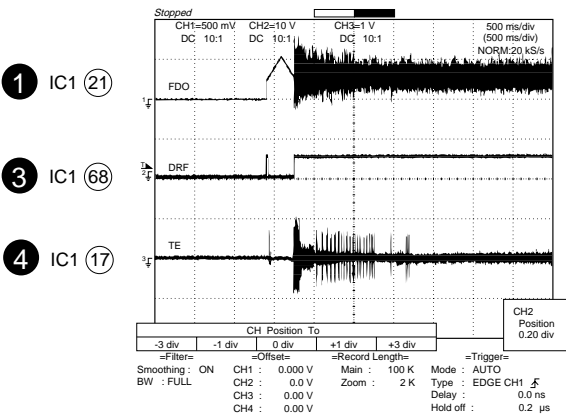
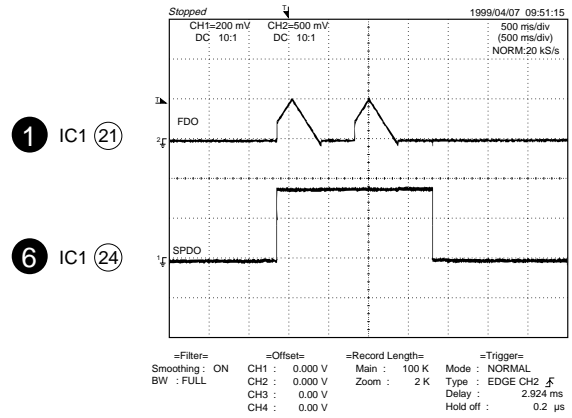
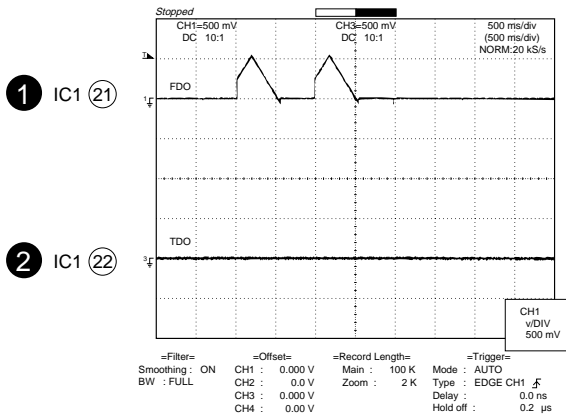

[4] Voltage

IC1		IC2		IC301		IC701			
PIN NO.	VOLTAGE	PIN NO.	VOLTAGE	PIN NO.	VOLTAGE	PIN NO.	VOLTAGE	PIN NO.	VOLTAGE
1	3.20 V	1	2.10 V	1	0 V	1	4.74 V	51	0 V
2	1.61 V	2	2.20 V	2	0 V	2	4.65 V	52	0 V
3	1.61 V	3	2.10 V	3	0.29 V	3	0 V	53	0 V
4	1.60 V	4	2.20 V	4	0.20 V	4	4.70 V	54	0 V
5	1.61 V	5	2.10 V	5	0 V	5	4.72 V	55	5.17 V
6	3.08 V	6	2.20 V	6	0.29 V	6	4.72 V	56	5.17 V
7	1.65 V	7	0 V	7	0.26 V	7	0 V	57	-29.70 V
8	1.65 V	8	4.37 V	8	0.29 V	8	0 V	58	0 V
9	1.65 V	9	5.02 V	9	0.29 V	9	0 V	59	-0.26 V
10	1.65 V	10	3.20 V			10	4.83 V	60	-0.24 V
11	1.48 V	11	1.62 V			11	2.27 V	61	-0.22 V
12	0 V	12	1.65 V			12	1.99 V	62	-0.20 V
13	1.65 V	13	1.62 V			13	0 V	63	-0.19 V
14	0 V	14	1.65 V			14	4.73 V	64	-0.19 V
15	1.65 V	15	1.62 V			15	0 V	65	-0.18 V
16	1.47 V	16	0 V			16	4.74 V	66	-0.17 V
17	1.48 V	17	1.62 V			17	0 V	67	-0.16 V
18	0 V	18	1.64 V			18	0 V	68	0 V
19	0 V	19	4.71 V			19	5.22 V	69	-29.90 V
20	0 V	20	4.71 V			20	0 V	70	-29.90 V
21	1.60 V	21	3.92 V			21	0 V	71	-29.90 V
22	0 V	22	3.11 V			22	4.68 V	72	-29.90 V
23	1.61 V	23	3.10 V			23	0 V	73	-29.90 V
24	1.61 V	24	2.50 V			24	0 V	74	-19.76 V
25	0 V	25	1.65 V			25	0 V	75	-27.40 V
26	0 V	26	0 V			26	5.20 V	76	-24.87 V
27	3.2 V	27	5.02 V			27	0 V	77	-22.29 V
28	0 V	28	8.68 V			28	5.01 V	78	-22.30 V
29	3.2 V	29	5.02 V			29	5.01 V	79	-30.13 V
30	0 V	30	0.59 V			30	2.64 V	80	-27.43 V
31	0 V	31	0.71 V			31	5.01 V	81	-14.50 V
32	1.59 V	32	0 V			32	5.01 V	82	-27.20 V
33	1.60 V	33	0 V			33	0 V	83	-19.30 V
34	3.20 V	34	0 V			34	0 V	84	-6.08 V
35	0 V	35	2.11 V			35	5.01 V	85	-21.85 V
36	0 V	36	2.20 V			36	1.67 V	86	-27.22 V
37	0 V					37	5.20 V	87	-21.89 V
38	0 V					38	5.01 V	88	-17.00 V
39	0 V					39	4.87 V	89	-27.38 V
40	0 V					40	0 V	90	-27.10 V
41	3.61 V					41	2.02 V	91	-27.07 V
42	0 V					42	0 V	92	-27.00 V
43	0 V					43	13.10 V	93	-27.00 V
44	1.80 V					44	0 V	94	-27.35 V
45	3.60 V					45	0 V	95	-27.27 V
46	0 V					46	4.74 V	96	-27.11 V
47	1.45 V					47	0 V	97	-27.00 V
48	1.49 V					48	4.61 V	98	-27.07 V
49	3.19 V					49	0 V	99	-27.00 V
50	3.79 V					50	0 V	100	-26.83 V
51	0 V								
52	0 V								
53	0 V								
54	0 V								
55	0 V								
56	0 V								
57	0 V								
58	0 V								
59	0 V								
60	3.20 V								
61	0 V								
62	0 V								
63	0.63 V								
64	0 V								
65	5.16 V								
66	5.18 V								
67	4.68 V								
68	0 V								
69	0 V								
70	0 V								
71	0 V								
72	0 V								
73	0 V								
74	4.86 V								
75	4.86 V								
76	3.01 V								
77	0 V								
78	1.12 V								
79	0 V								
80	3.20 V								

IC302	
PIN NO.	VOLTAGE
1	2.57 V
2	0 V
3	0 V
4	0 V
5	0 V
6	5.22 V
7	10.18 V
8	4.76 V
9	0 V
10	0 V
11	5.23 V
12	0 V
13	5.23 V
14	0 V
15	0 V
16	2.59 V
17	5.24 V
18	0 V
19	0 V
20	10.18 V
21	0 V
22	2.57 V

IC303	
PIN NO.	VOLTAGE
1	1.97 V
2	5.15 V
3	1.97 V
4	1.96 V
5	0 V
6	0 V
7	5.21 V
8	3.59 V
9	5.15 V
10	0 V
11	2.01 V
12	1.25 V
13	2.27 V
14	1.13 V
15	1.10 V
16	1.96 V
17	0 V
18	1.29 V
19	2.08 V
20	1.29 V
21	1.95 V
22	1.95 V
23	5.15 V
24	3.65 V

IC601		IC901	
PIN NO.	VOLTAGE	PIN NO.	VOLTAGE
1	0 V	1	52.80 V
2	0 V	2	21.60 V
3	0 V	3	9.60 V
4	5.10 V	4	-9.70 V
5	5.10 V	5	-21.60 V
6	5.10 V	6	-48.80 V
7	5.10 V	7	0 V
8	5.11 V	8	-19.70 V
9	5.10 V	9	-22.90 V
10	5.10 V	10	-22.10 V
11	5.10 V	11	-18.60 V
12	5.10 V	12	-51.30 V
13	5.10 V	13	51.40 V
14	5.10 V	14	-0.14 V
15	5.10 V	15	-0.13 V
16	5.10 V	16	-50.04 V
17	5.10 V	17	-0.14 V
18	5.10 V	18	-0.14 V
19	5.10 V		
20	5.10 V		
21	5.10 V		
22	5.10 V		
23	10.20 V		
24	0 V		

IC851	
PIN NO.	VOLTAGE
1	5.22 V
2	13.11 V
3	20.66 V
4	0 V
5	19.72 V
6	10.22 V
7	8.67 V

CHAPTER 6. CIRCUIT SCHEMATICS AND PARTS LAYOUT

[1] Wiring side of P.W.Board

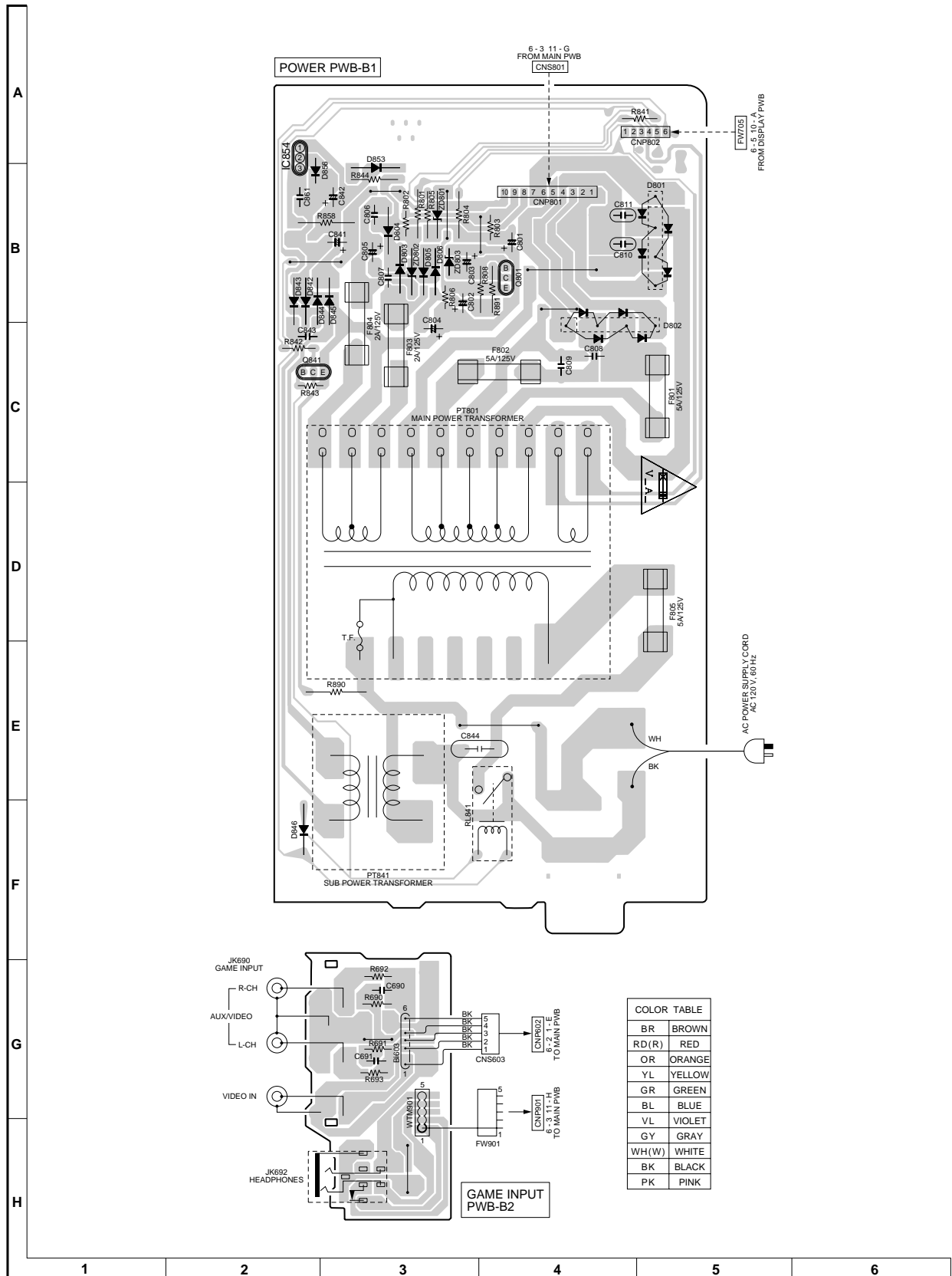

Figure 6-1 WIRING SIDE OF P.W.BOARD (1/7)

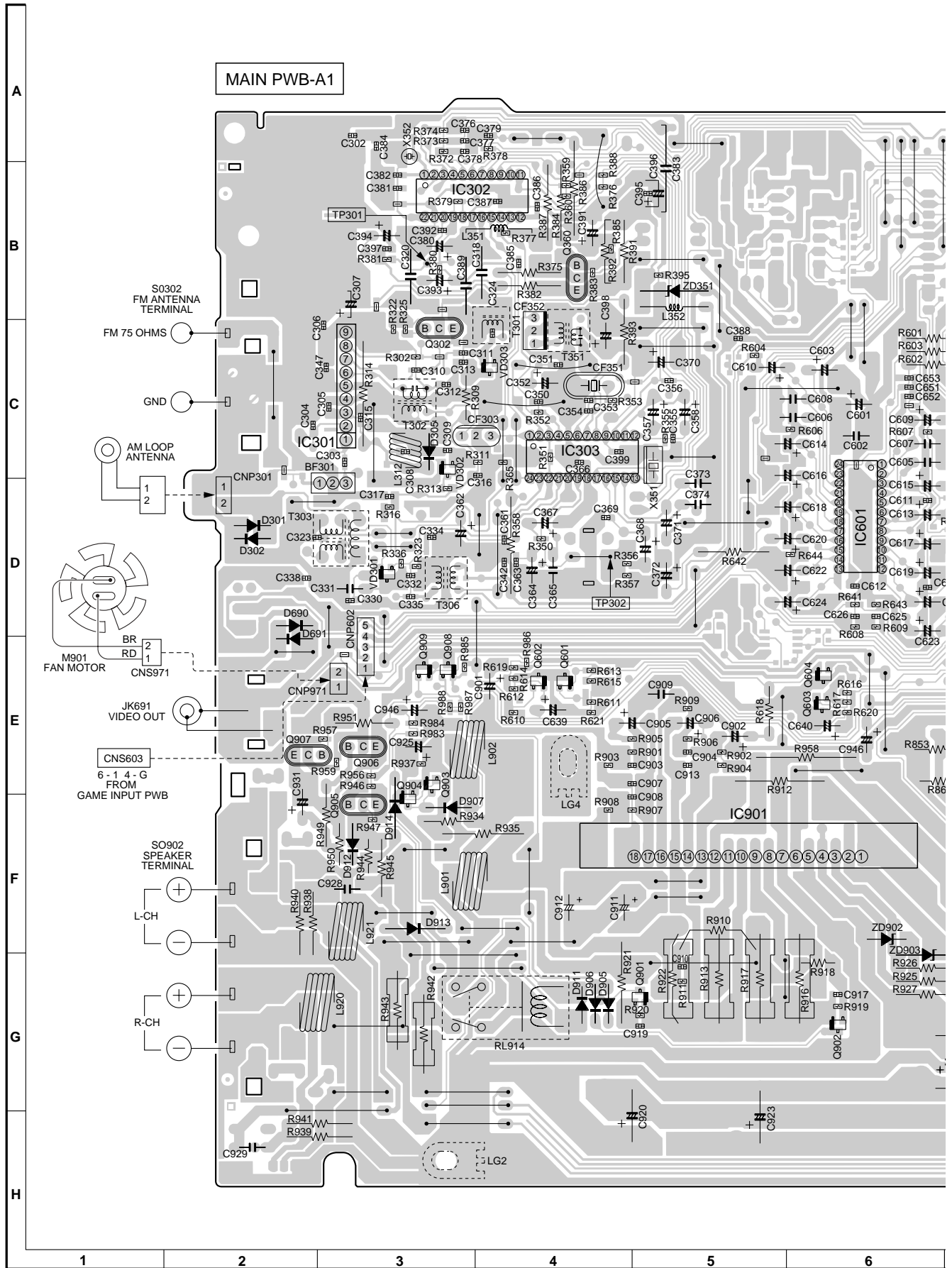

Figure 6-2 WIRING SIDE OF P.W.BOARD (2/7)

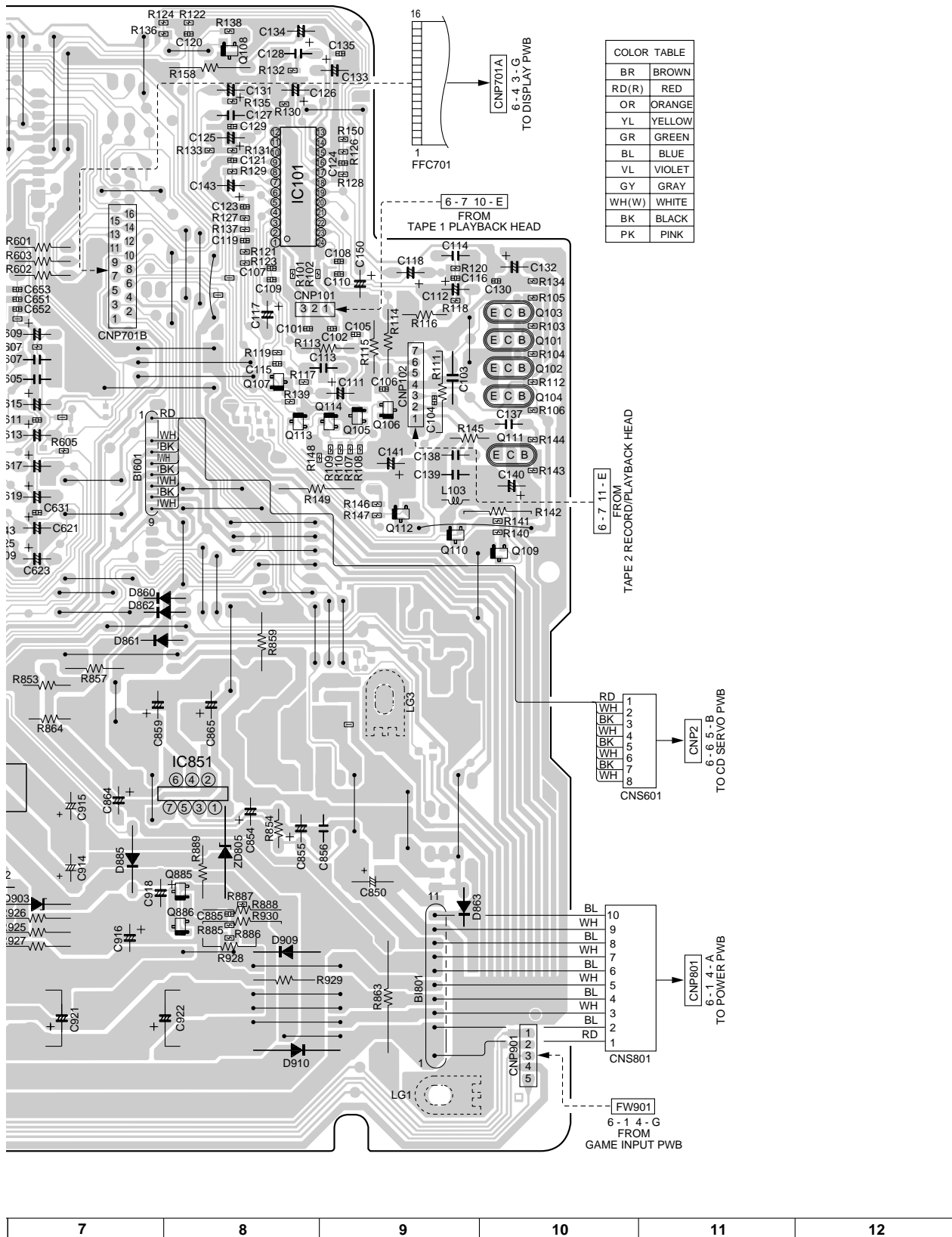

Figure 6-3 WIRING SIDE OF P.W.BOARD (3/7)

Ń6*%Ž 6CSP` chU` \VTg\ba` _bVTg\ba` \fa/g` \XTe!`
 <g` [bcXf` Ybe` gl X Xagel !

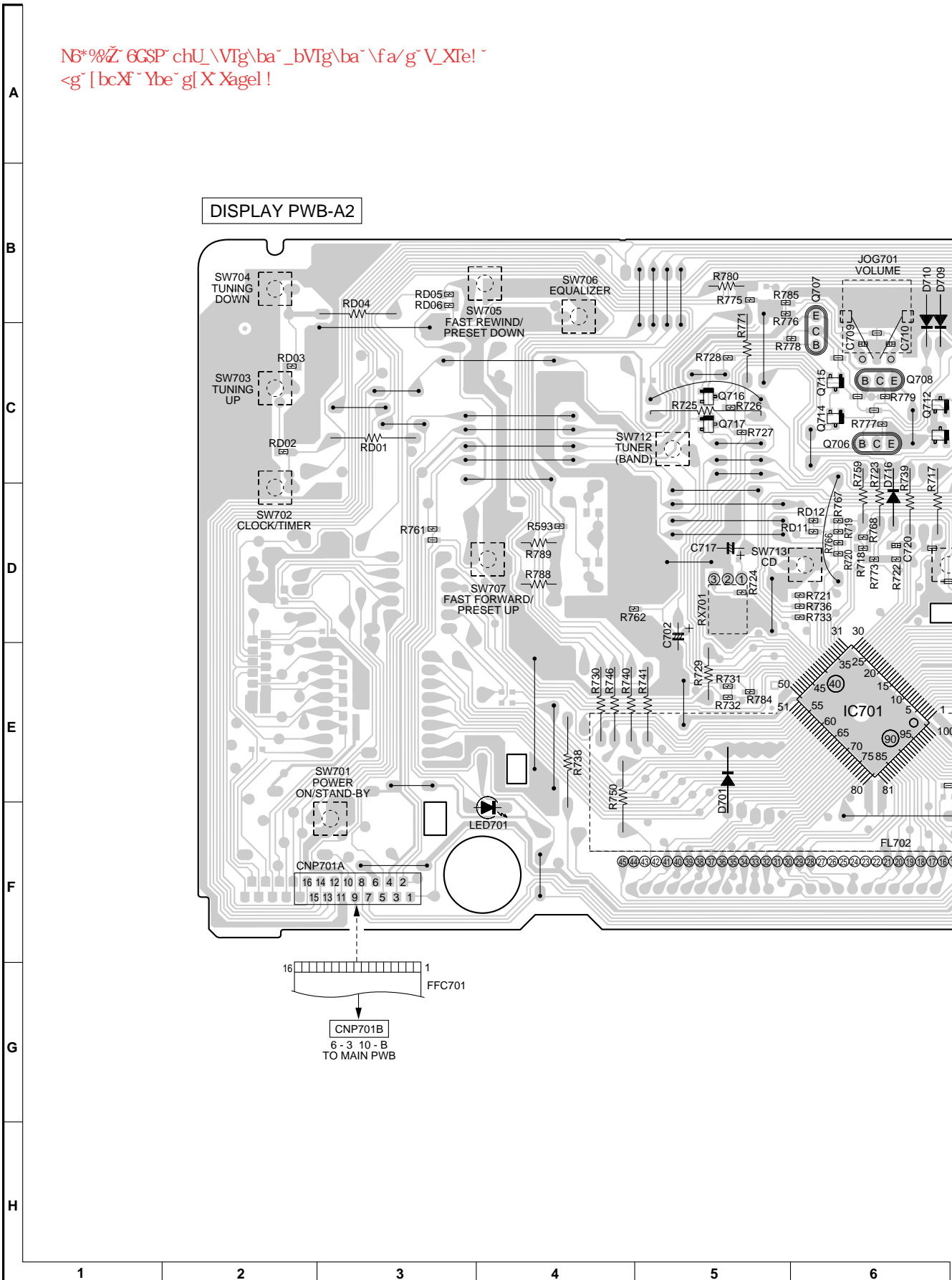
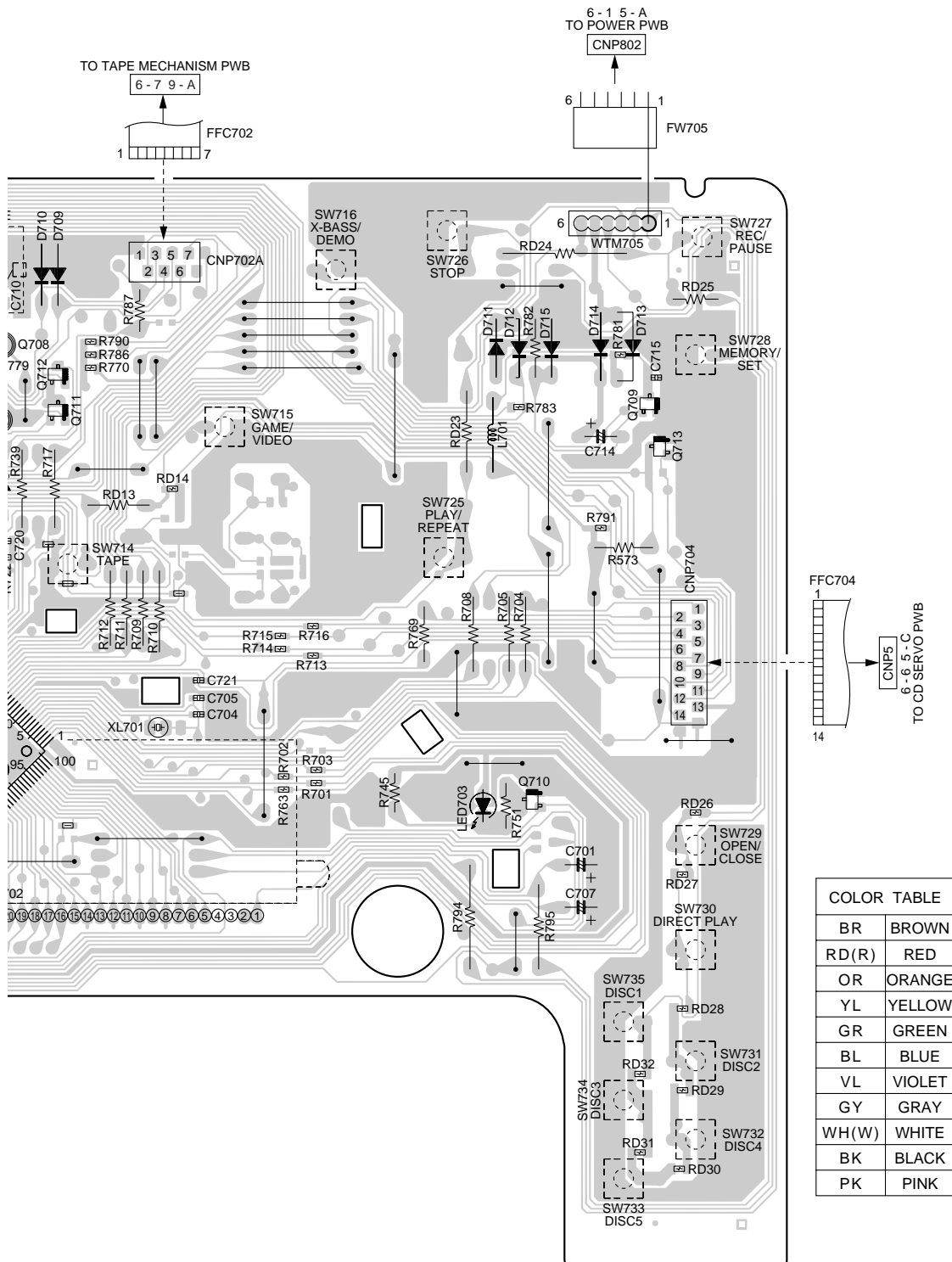

Figure 6-4 WIRING SIDE OF P.W.BOARD (4/7)



COLOR TABLE	
BR	BROWN
RD(R)	RED
OR	ORANGE
YL	YELLOW
GR	GREEN
BL	BLUE
VL	VIOLET
GY	GRAY
WH(W)	WHITE
BK	BLACK
PK	PINK



Figure 6-5 WIRING SIDE OF P.W.BOARD (5/7)

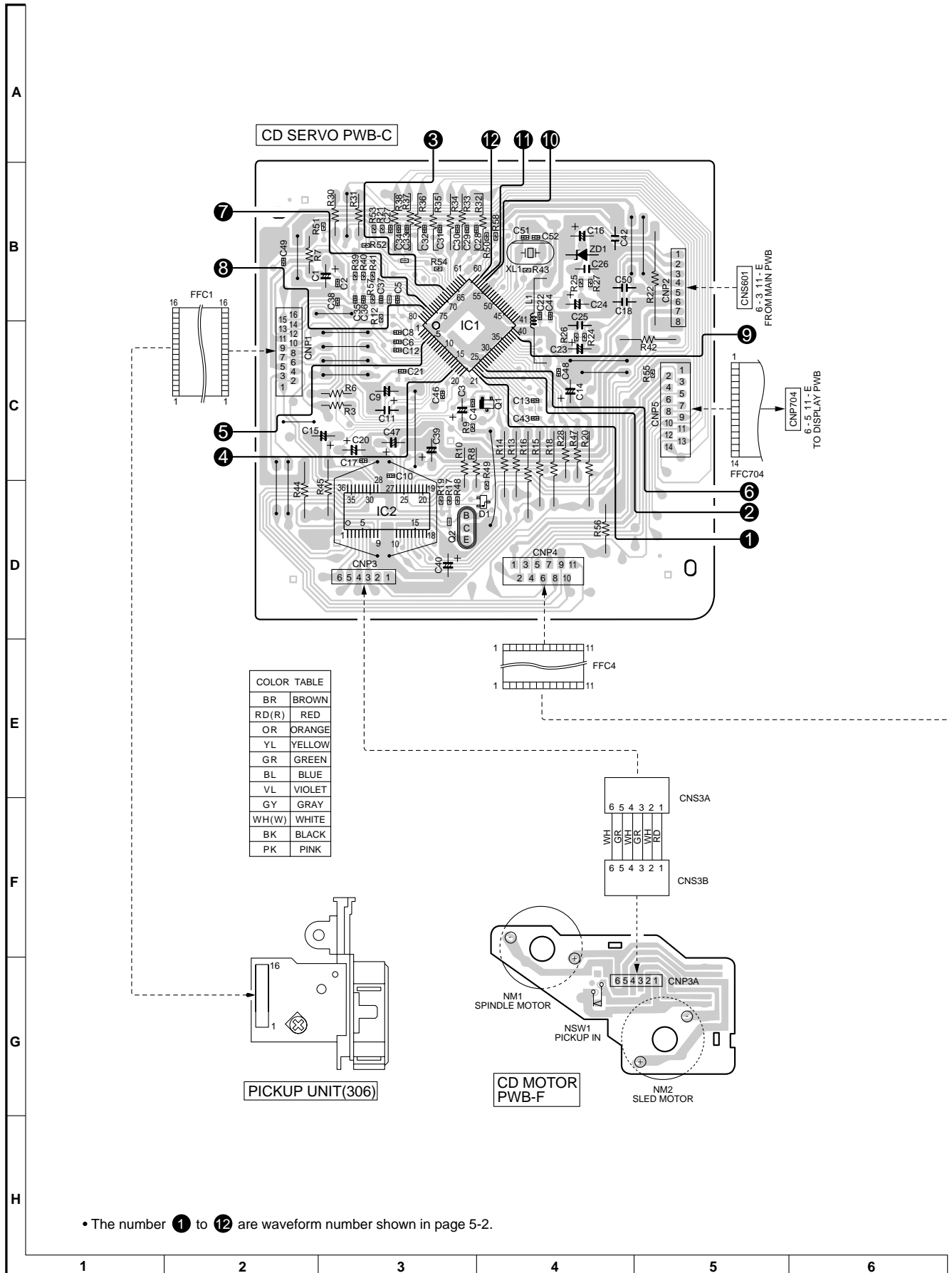

• The number ① to ⑫ are waveform number shown in page 5-2.

Figure 6-6 WIRING SIDE OF P.W.BOARD (6/7)

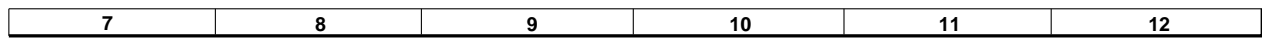
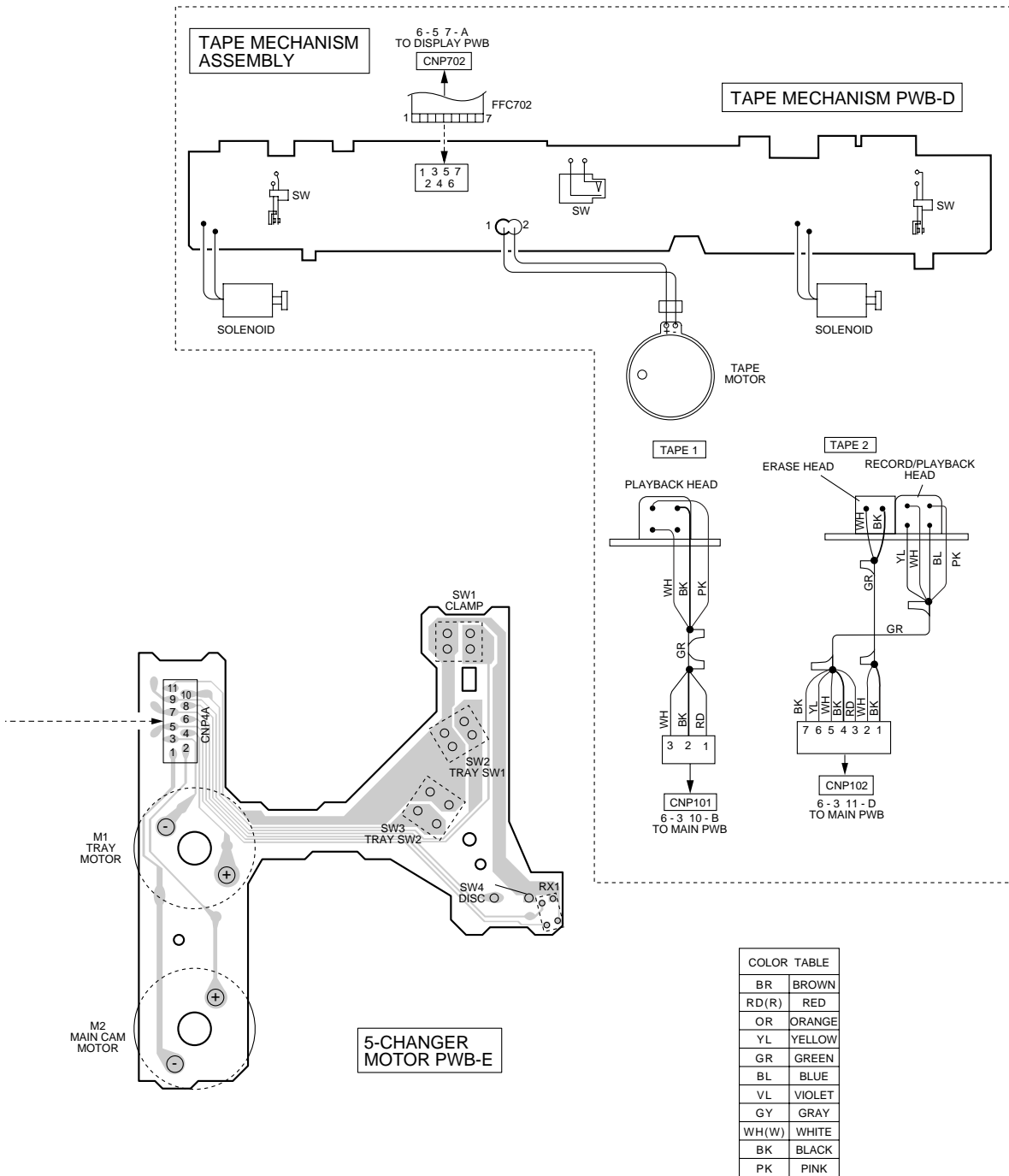

Figure 6-7 WIRING SIDE OF P.W.BOARD (7/7)

[2] Schematic diagram

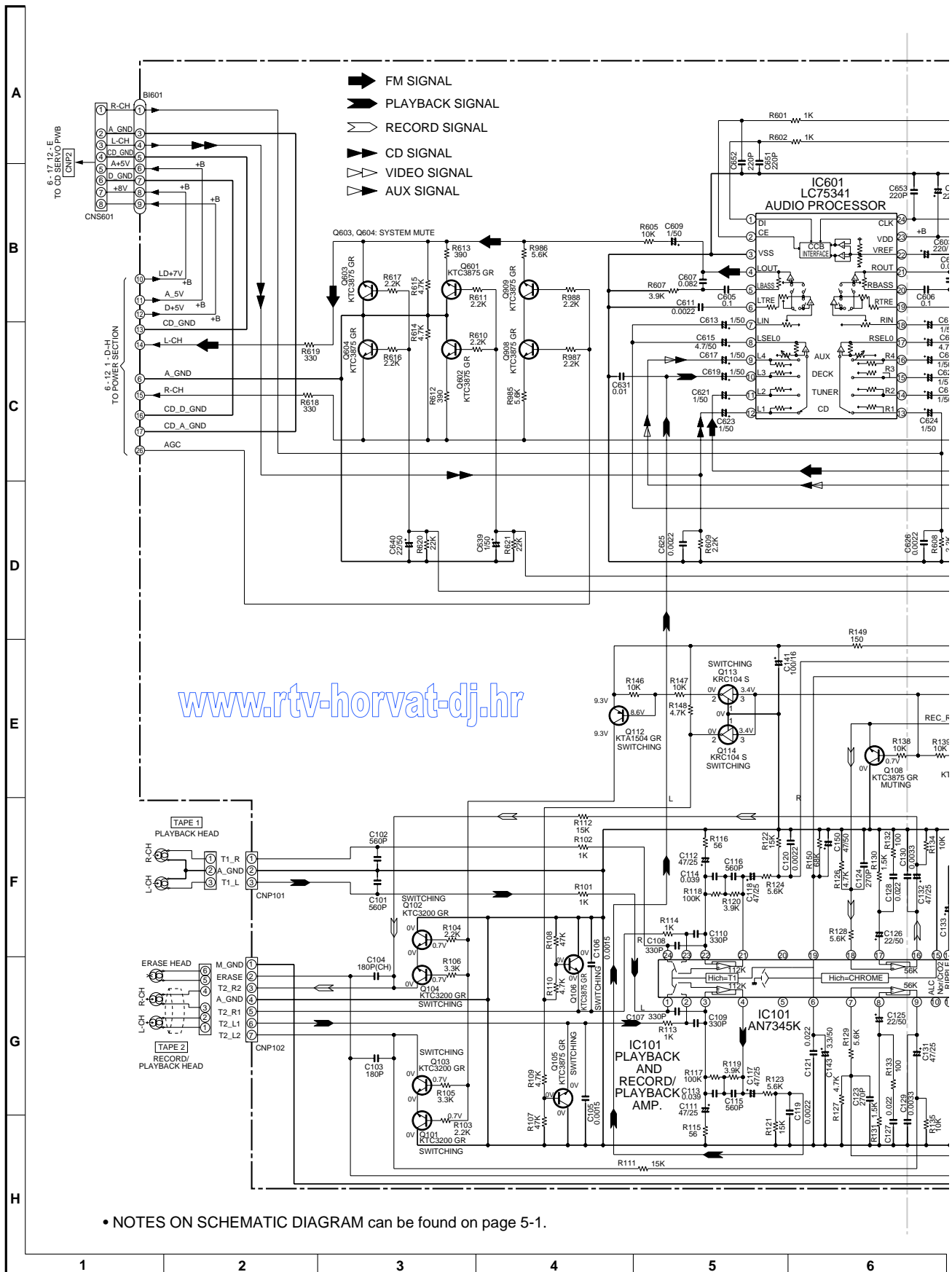

Figure 6-8 SCHEMATIC DIAGRAM (1/10)

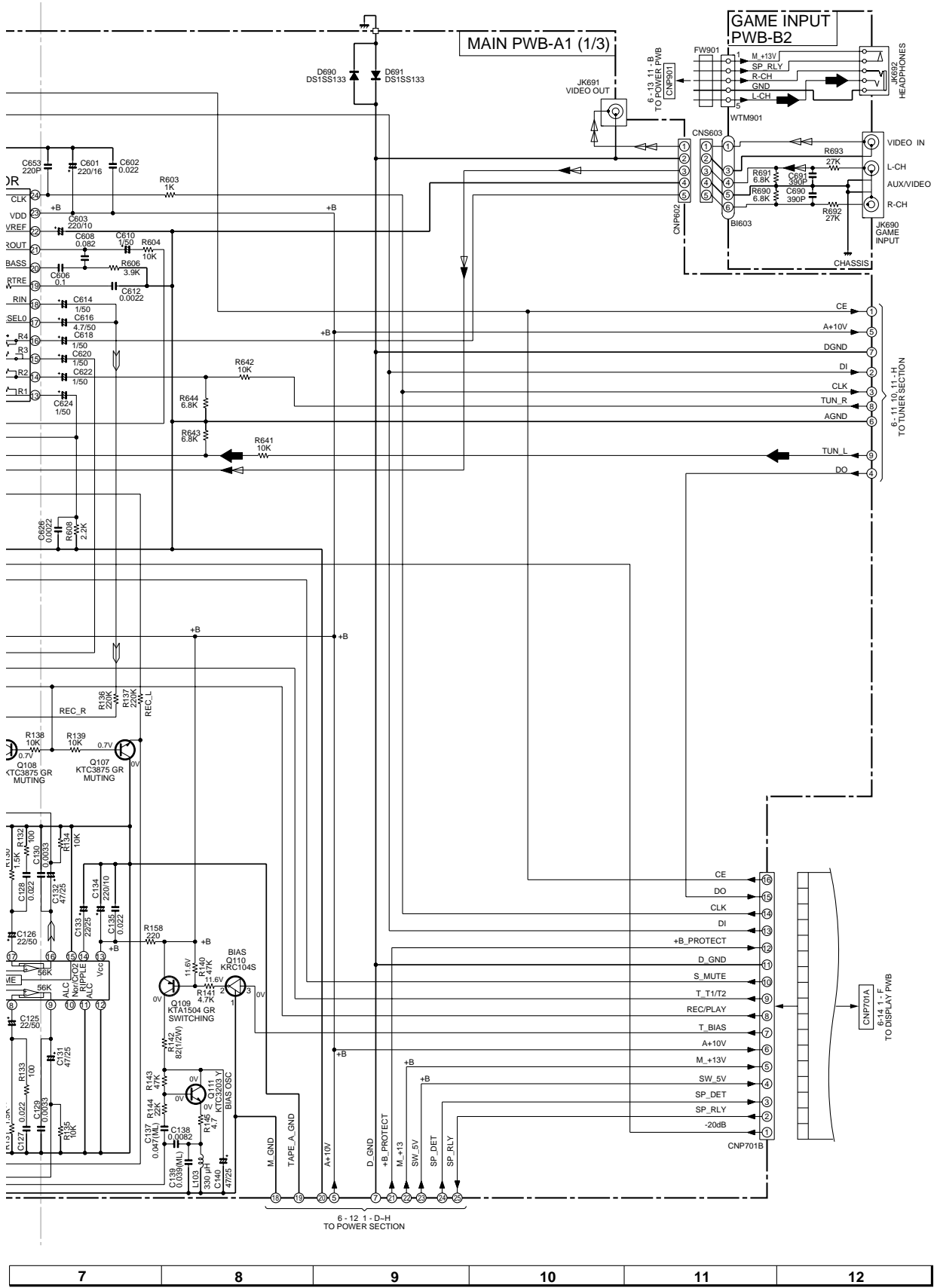
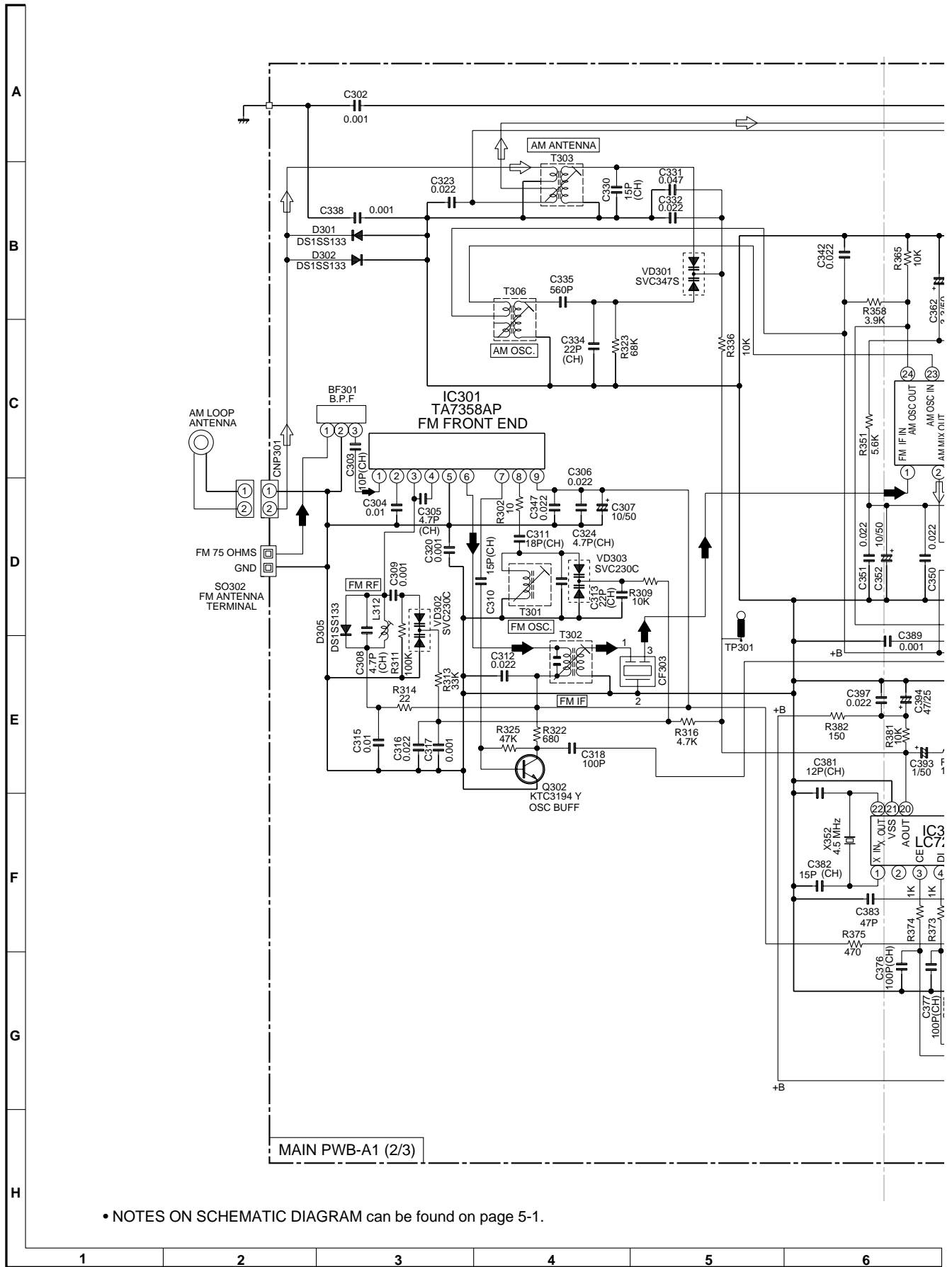

Figure 6-9 SCHEMATIC DIAGRAM (2/10)



• NOTES ON SCHEMATIC DIAGRAM can be found on page 5-1.

Figure 6-10 SCHEMATIC DIAGRAM (3/10)

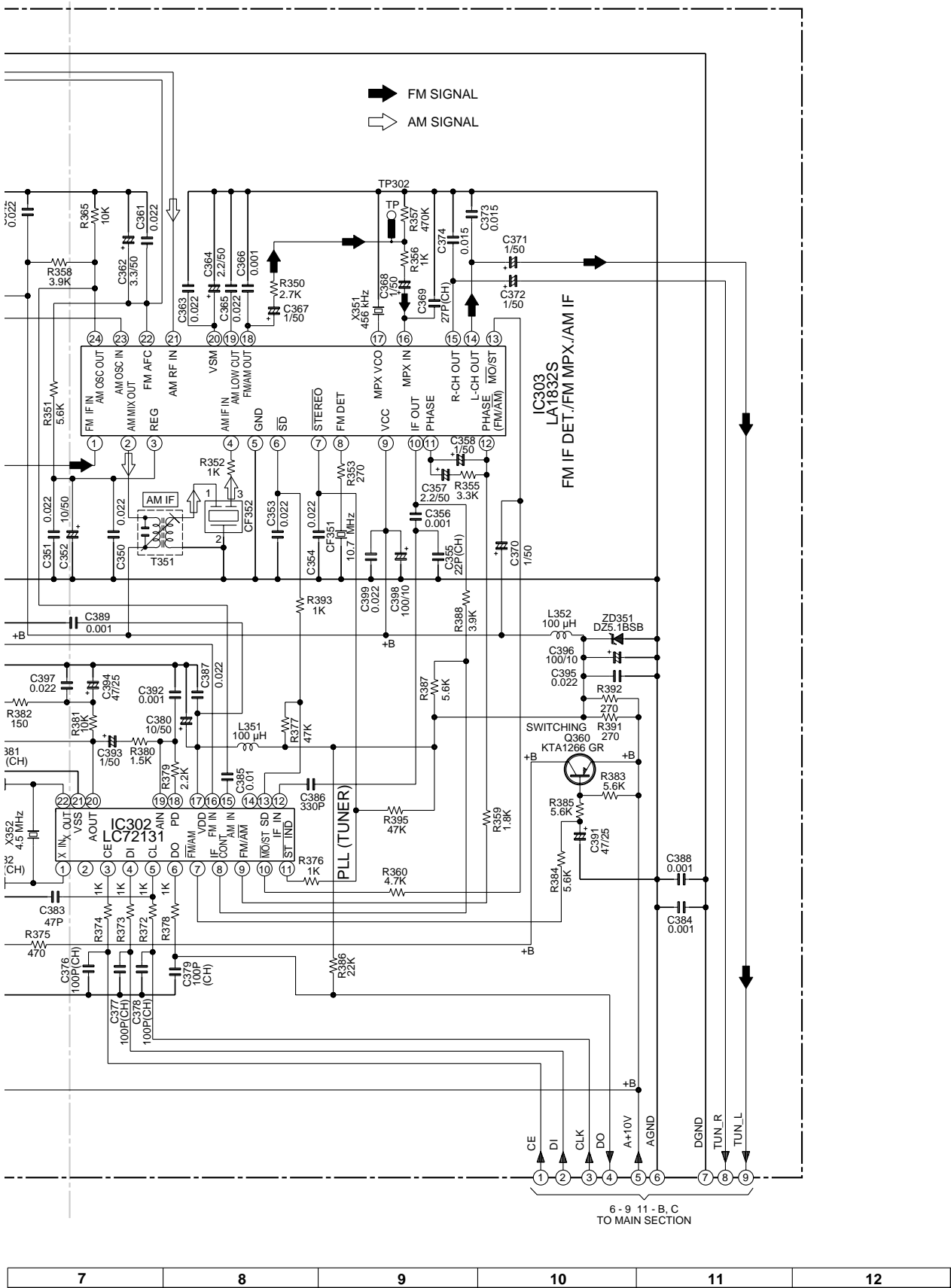
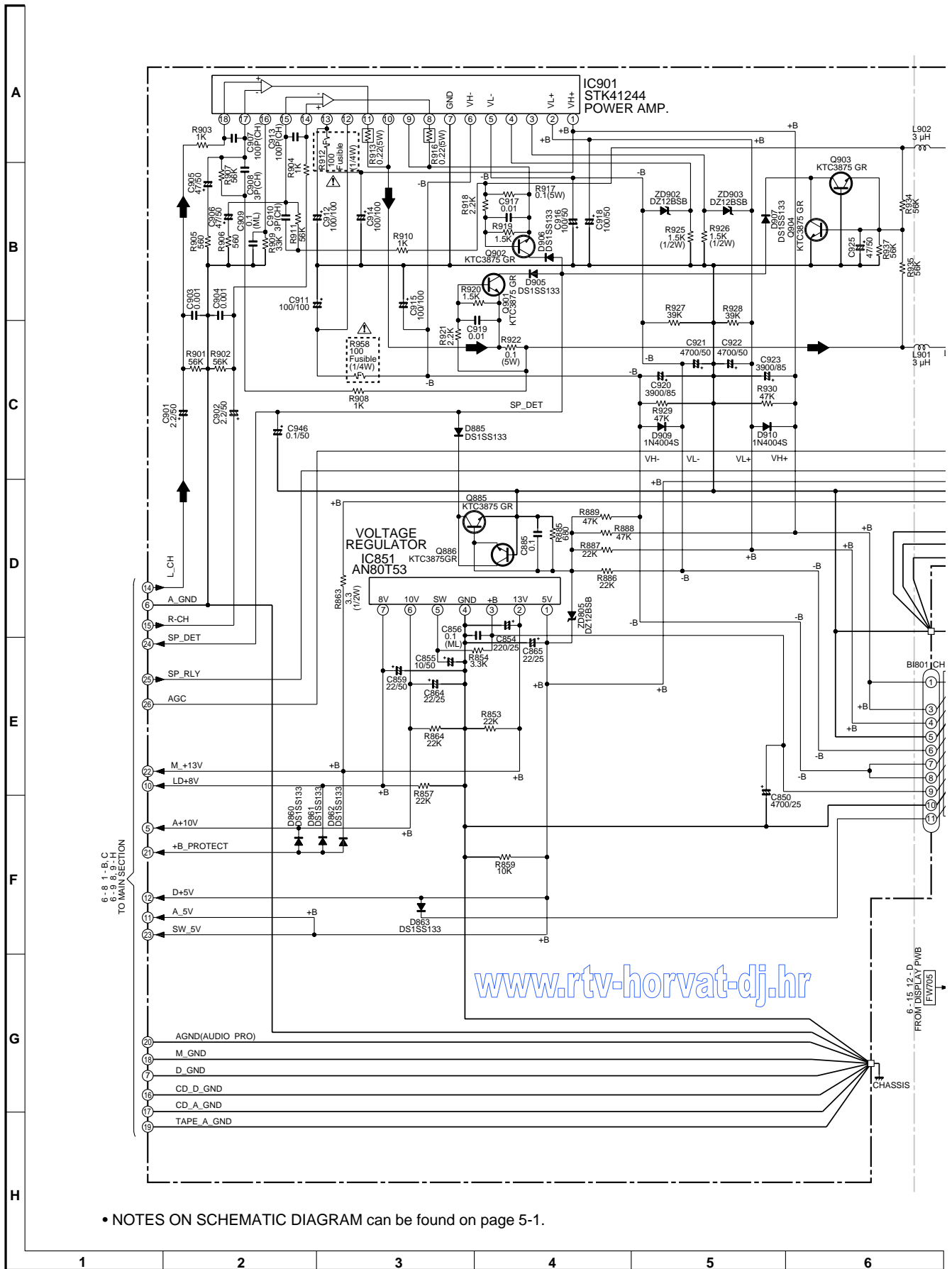

Figure 6-11 SCHEMATIC DIAGRAM (4/10)



• NOTES ON SCHEMATIC DIAGRAM can be found on page 5-1.

Figure 6-12 SCHEMATIC DIAGRAM (5/10)

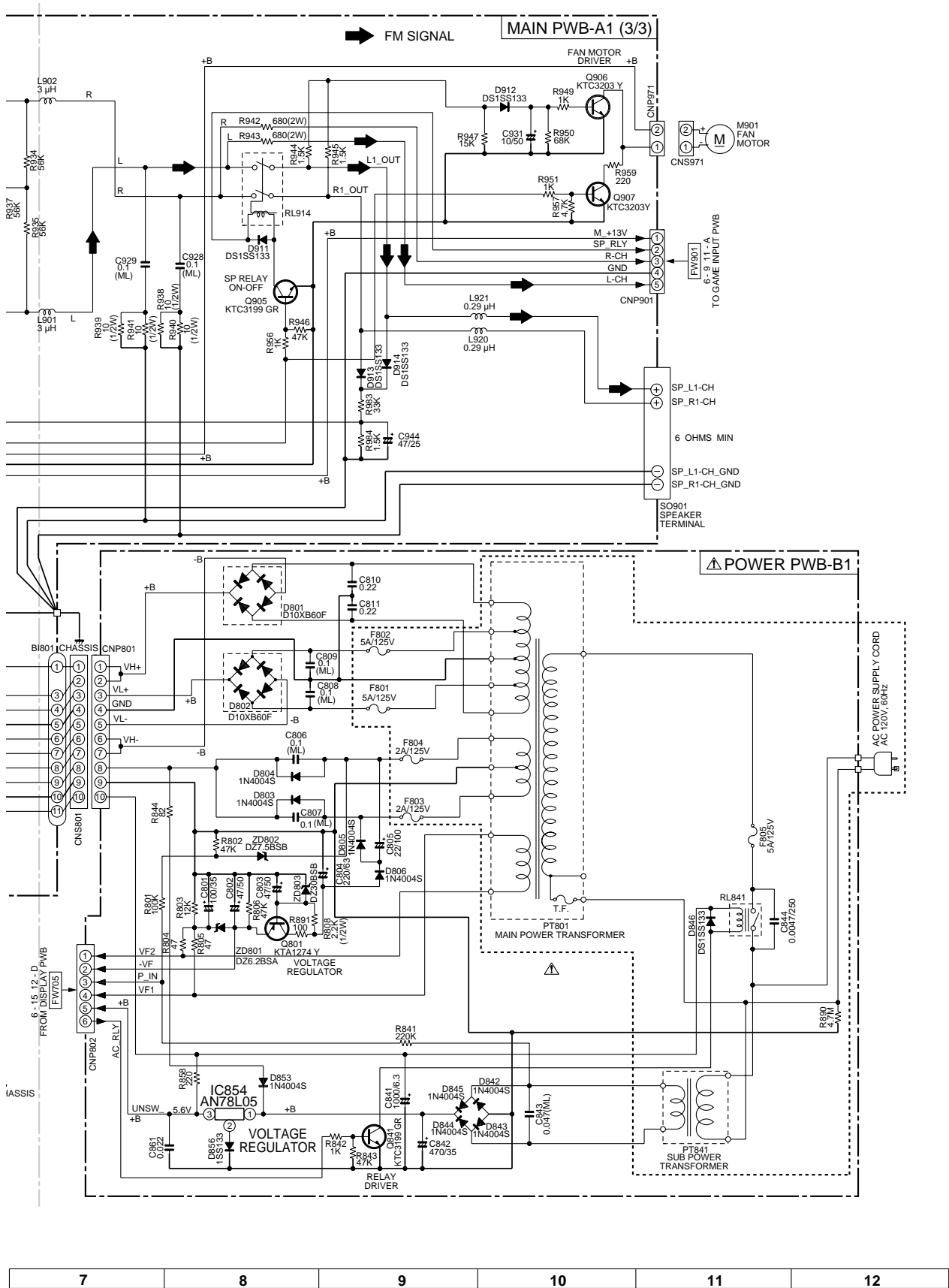

Figure 6-13 SCHEMATIC DIAGRAM (6/10)

N3*%Z̃ 6CSP`chU`\\VTg\ba`_bVTg\ba`~fa/g`V_XTe!`~<g`[bcXf`Ybe`g[X`Xägel!

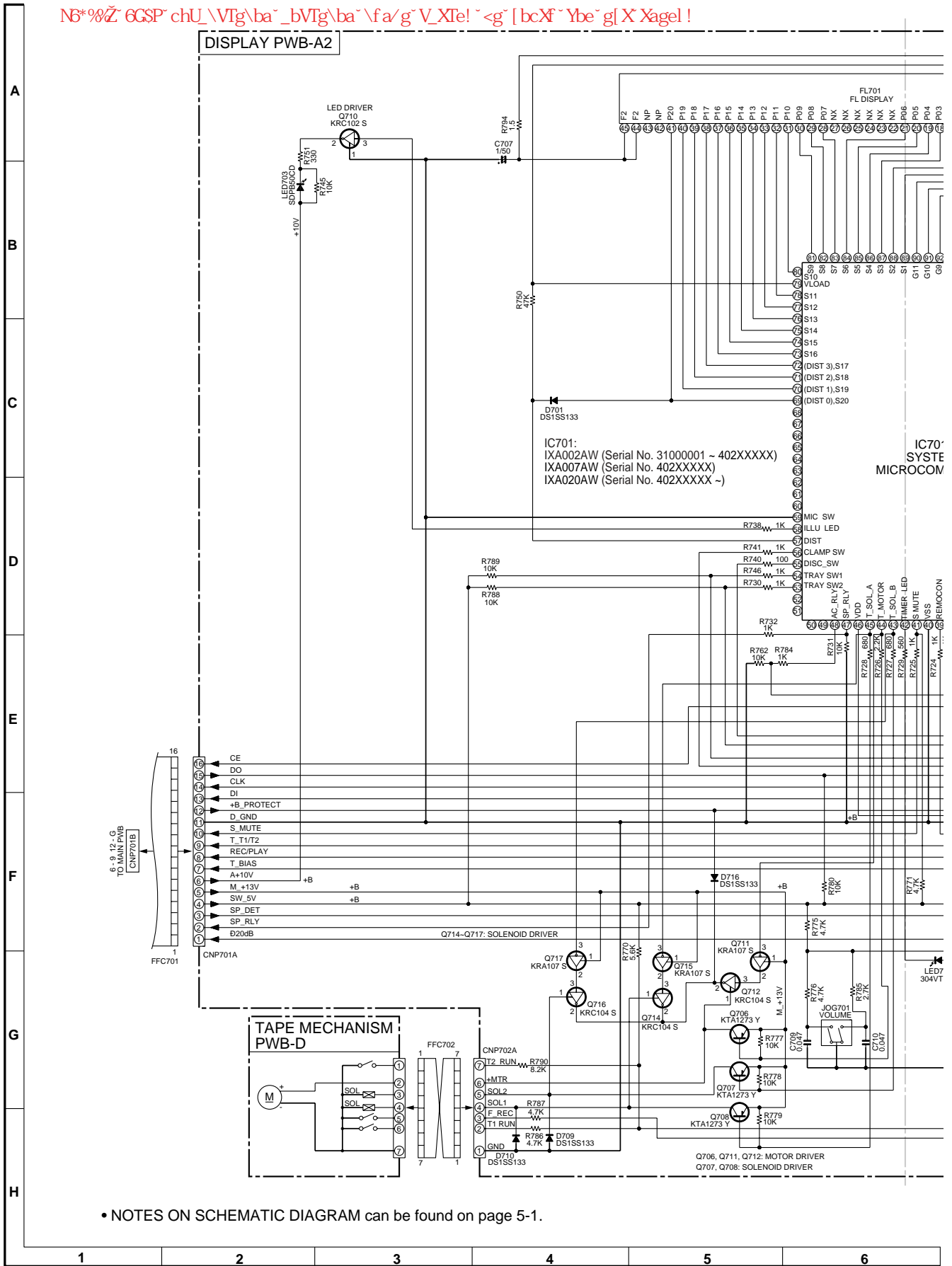

Figure 6-14 SCHEMATIC DIAGRAM (7/10)

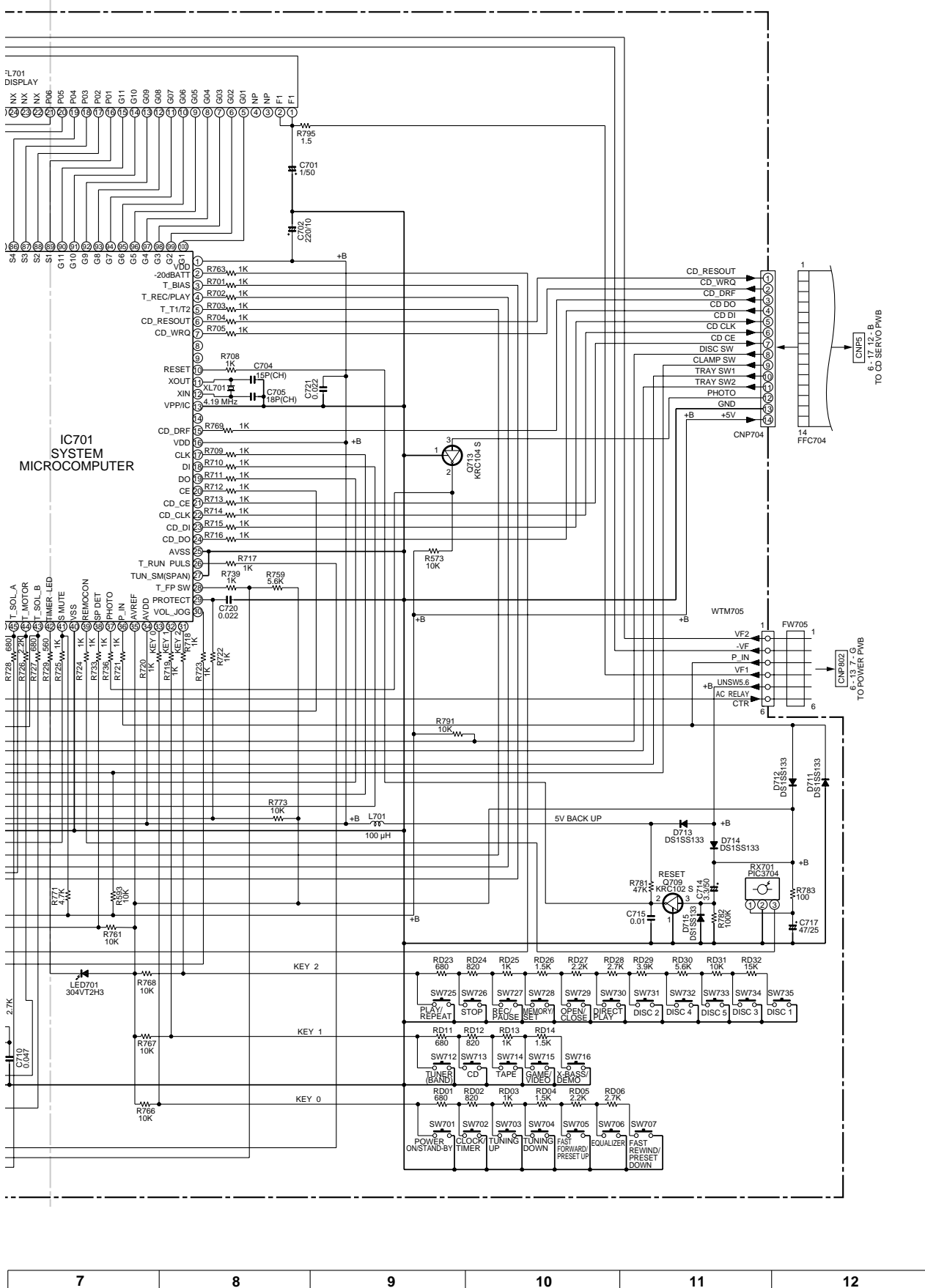
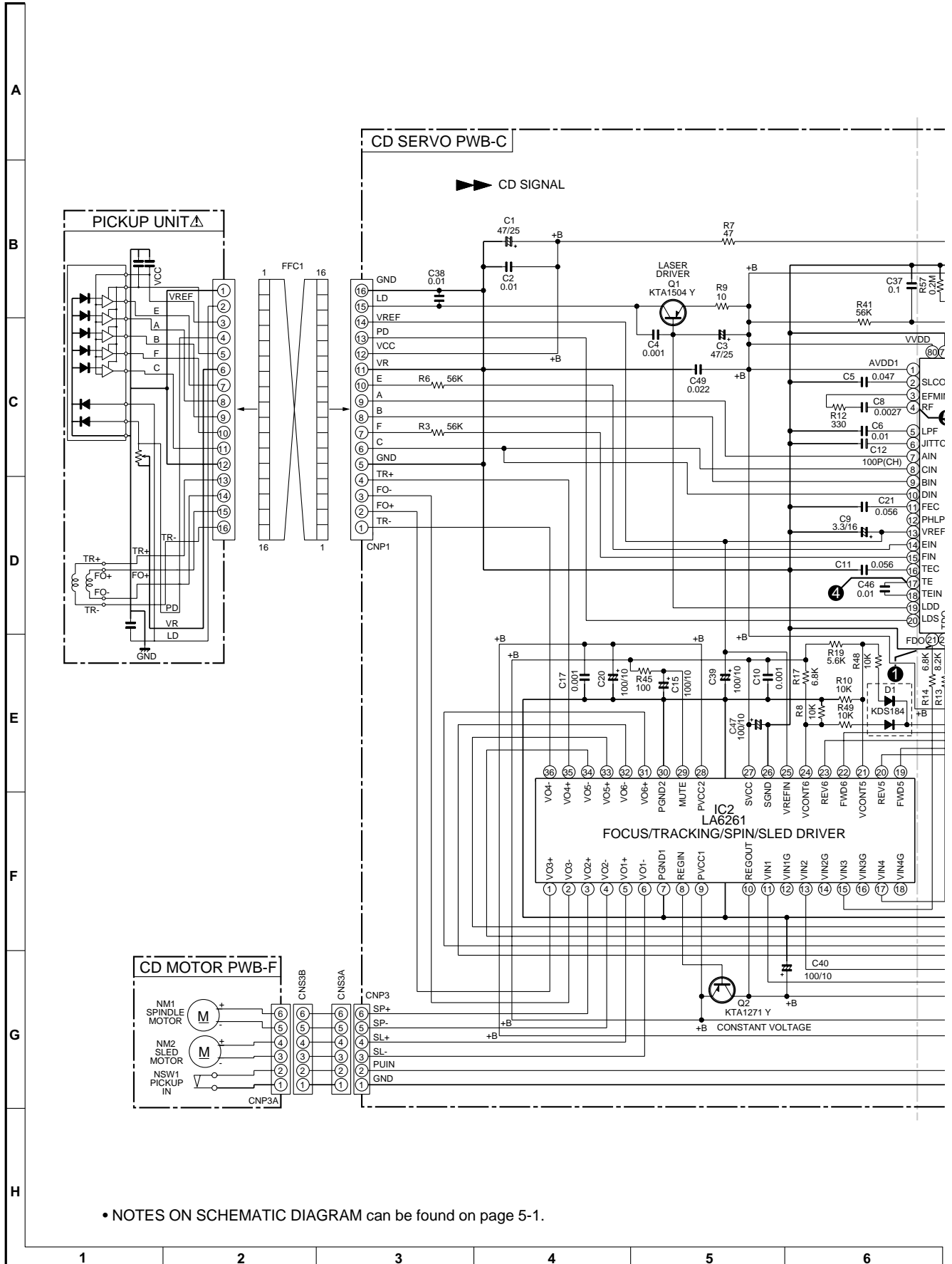
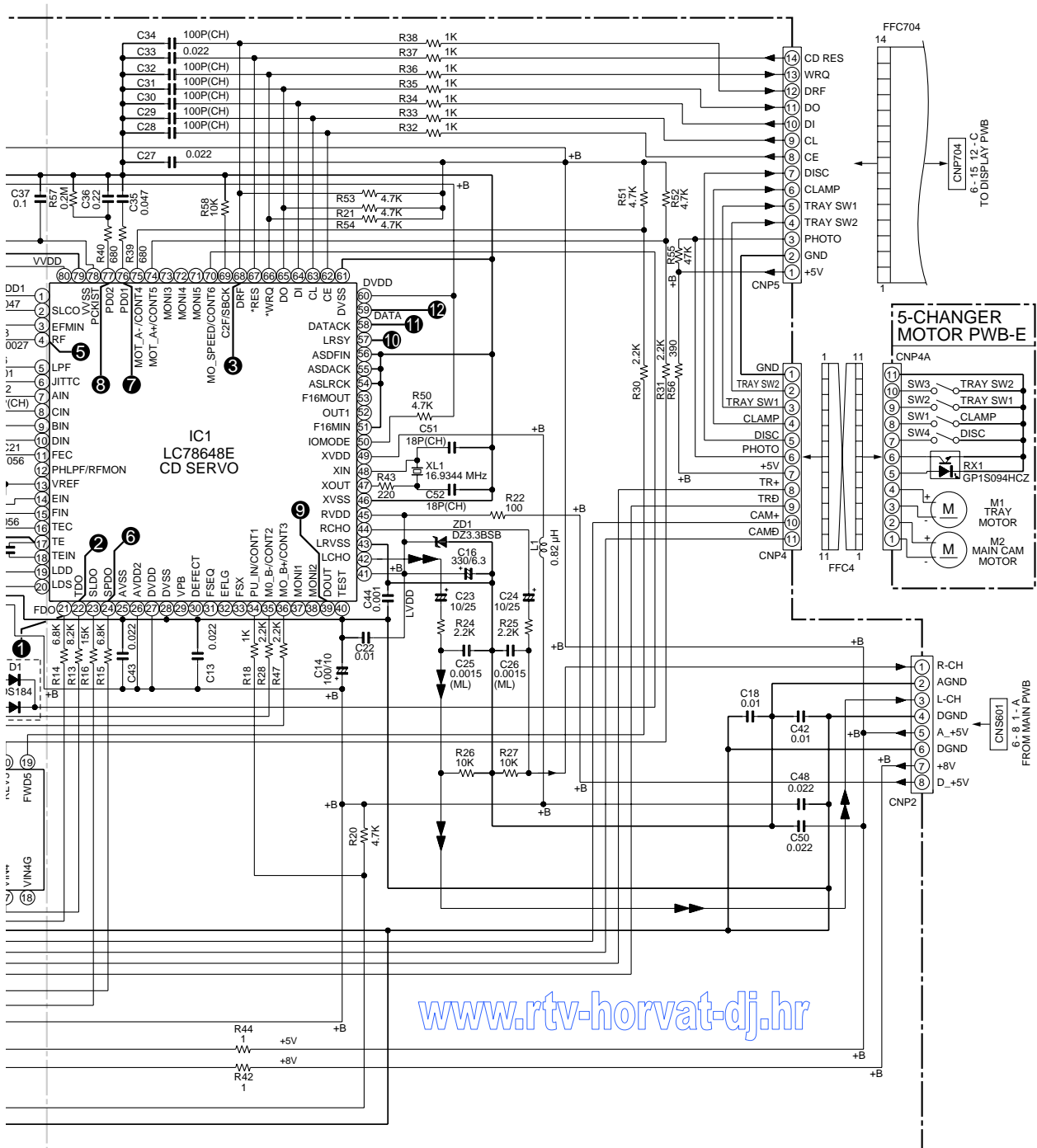

Figure 6-15 SCHEMATIC DIAGRAM (8/10)



• NOTES ON SCHEMATIC DIAGRAM can be found on page 5-1.

Figure 6-16 SCHEMATIC DIAGRAM (9/10)



• The number 1 to 12 are waveform number shown in page 5-2.

7	8	9	10	11	12
---	---	---	----	----	----

Figure 6-17 SCHEMATIC DIAGRAM (10/10)

CHAPTER 7. FLOWCHART

[1] Troubleshooting

1. When the CD does not function

The CD section may not operate when the objective lens of the optical pickup is dirty. Clean the objective lens, and check the playback operation. When this section does not operate even after the above step is taken, check the following items.

Remove the cabinet and follow the trouble shooting instructions.

"Track skipping and/or no TOC (Table Of Contents) may be caused by build up of dust other foreign matter on the laser pickup lens. Before attempting any adjustment make certain that the lens is clean. If not, clean it as mentioned below."

Turn the power off.

Gently clean the lens with a lens cleaning tissue and a small amount of isopropyl alcohol.

Do not touch the lens with the bare hand.

		Parts code
1.	CD optical pickup Lens cleaner disc	UDSKA0004AFZZ

HOW TO USE

- Using the brush in the cleaner cap, apply 1 or 2 drops of the cleaning fluid to the brush on the CD cleaner disc which has the mark next to it.
- Place the CD cleaner disc onto the CD disc tray with the brush side down, then press the play button.
- You will hear music for about 20 seconds and the CD player will automatically stop. If it continuous to turn, press the stop button.

CAUTION

- The CD lens cleaner should be effective for 30-50 operations, however if the brushes become worn out earlier then please the cleaner disc.
- If the CD cleaner brushes become very wet then wipe off any excess fluid with a soft cloth.
- Do not drink the cleaner fluid or allow it to come in contact with the eyes. In the event of this happening then drink and / or rinse with clean water and seek medical advice.
- The CD cleaner disc must not be used on car CD players or on computer CD-ROM drives.
- All rights reserved. Unauthorized duplicating, broadcasting and renting this product is prohibited by law.

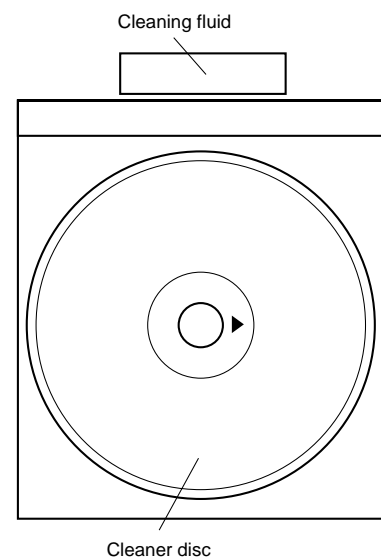

2. When a CD cannot be played

2.1. "E-CD01" is displayed.

- Check the power to IC1 (LC78648E), the presence of the clock signal (16.9344 MHz) and the status of the RESET terminal (pin 67 on IC1).
- Does the pickup move to the PICKUP-IN Switch (SW1A) position?

If (1) and (2) are OK, check the system microcomputer (especially the communication line with the DSP).

2.2. Pressing the CD operation key is accepted, but playback does not occur.

- Focus-HF system check
- Tracking system check
- Spin system check
- PLL system check
- Others

(1) Focus-HF system check.

Although a CD is inserted and the cover is closed, "NO DISC" is displayed.

Press the Tray1 CD Eject Button without inserting a disc, and try starting the playback operation.

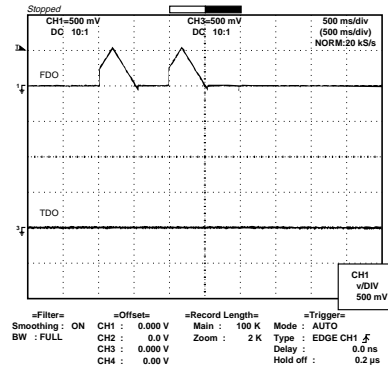

Figure 1

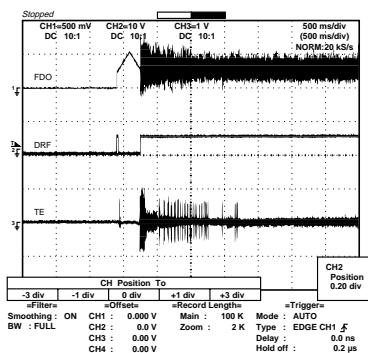
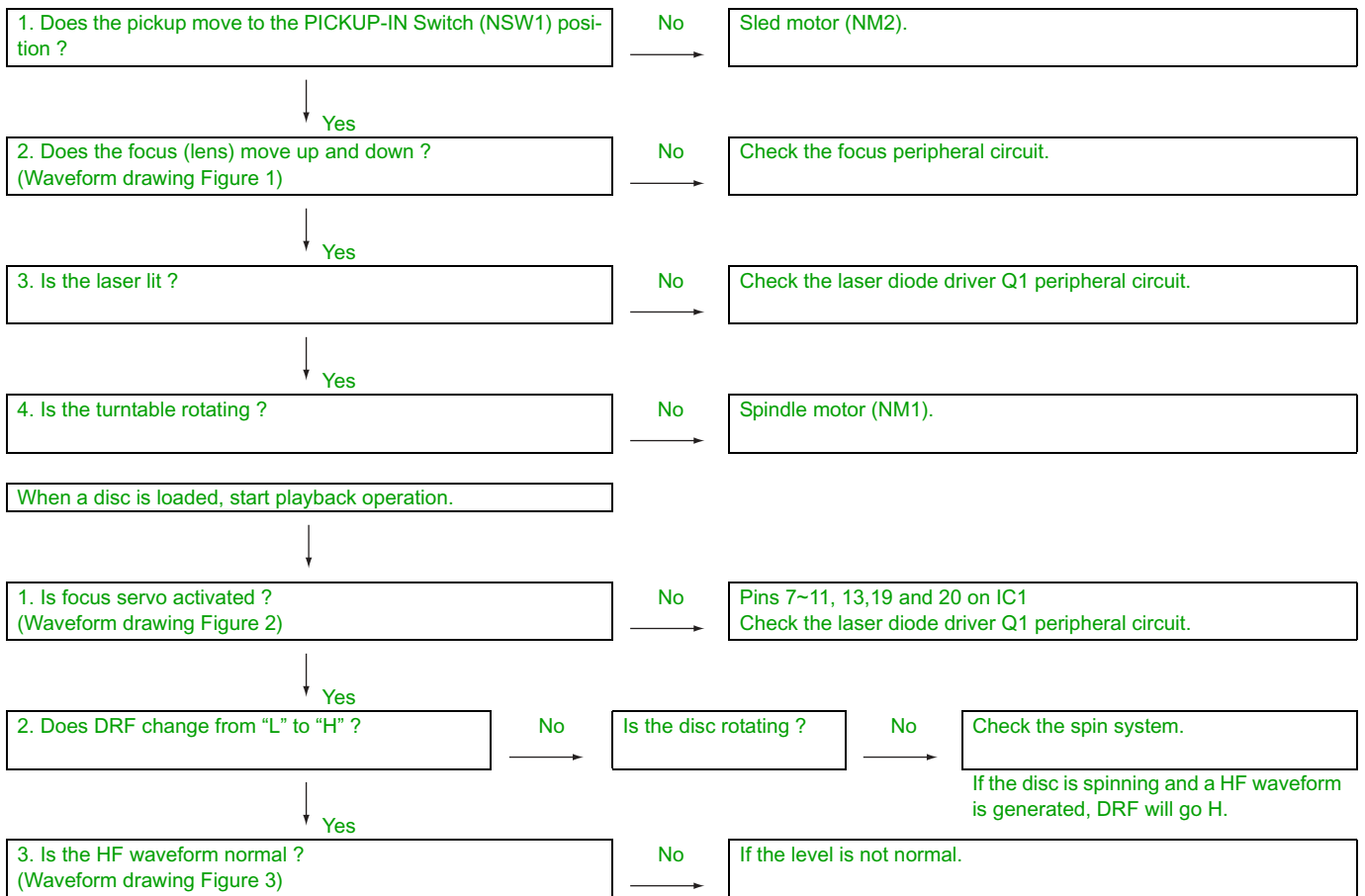

Figure 2

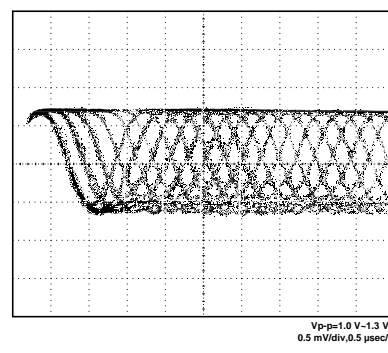

Figure 3

(2) Focus-HF system check.

Check the TE waveform at pin 17 on IC1.

If the waveform shown in Figure 4 appears and soon after NO DISC appears ?

Yes
The tracking servo is not activated.
Check the peripheral circuits at pins 16, 17 and 22 on IC1, and FFC1.

No

"Initialization" is possible, but play is not possible ?

Yes
A normal jump operation cannot be completed or the beginning of the track cannot be found.
Check the around pin 22 on IC1.

No

"Initialization" is not possible.

Data cannot be read. Check the VCO-PLL (Pin76~80 on IC1) system.

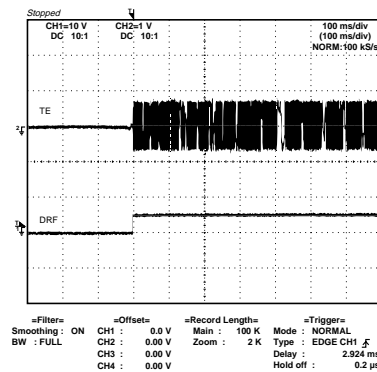

Figure 4

(3) Spin system check.

Press the OPEN/CLOSE switch without inserting a disc, and then try starting the play operation.

1. The turntable rotates a little ?
(Waveform drawing Figure 5)

Yes
The spin driver circuit is OK.

No

2. The turntable doesn't rotate.

Check around pin 24 on IC1, pins 3 and 4 on IC2, and CNS3A/B.

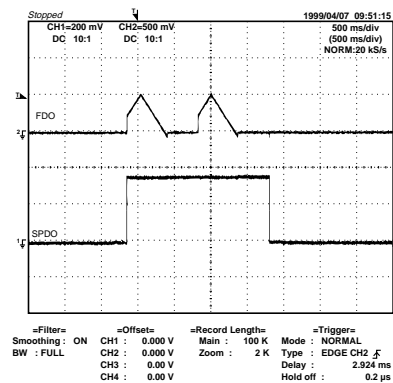

Figure 5

CD-ES900/CD-ES99

(4) PLL system check.

When a disc is loaded, start play operation.

The HF waveform is normal, but the TOC data cannot be read.

Check the PDO waveform. (Figure 6)

Check around pins 76~80 on IC1.

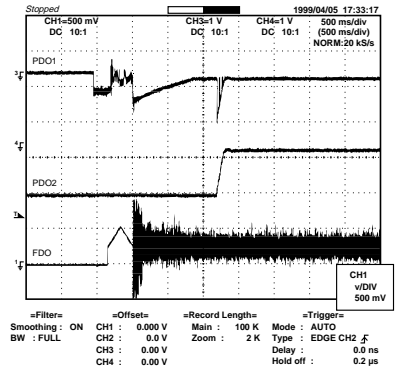

Figure 6

(5) Others.

The HF waveform is normal and the time is displayed normally, but no sound is produced. Or the sound has drop-outs.

Is pin 69 (C2F) on IC1 "L" ?

No →

There are too many error flags on a damaged disc which makes error correction impossible.

Yes ↓

1. When playing at normal speed. Check the peripheral circuit at pin 39 (DOUT) on IC1 and the waveform (Figure 7).

Check again using a known good disc.

If OK, Check the unit.

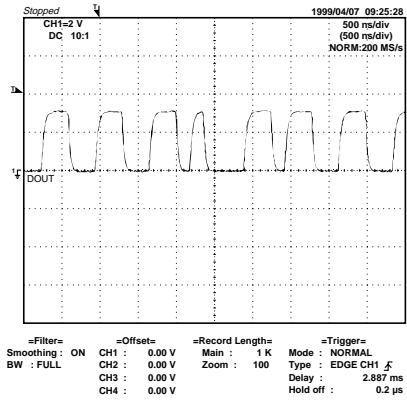

Figure 7

CHAPTER 8. OTHER

[1] Function table of IC

IC1 VHiLC78648E-1: CD Digital Signal Processor (LC78648E) (1/2)

Pin No.	Terminal Name	Input/Output	Setting in Reset	Function	
1	AVDD1	Output	—	Analog power supply pin 1.	
2	SLCO	Output	—	slice level control.	Slice level Control output pin.
3	EFMIN	Input	—	RF signal input pin.	
4	RF	Output	—	RF signal Output pin.	
5	LPF	Output	—	RF signal DC level detection LPF capacitor connection pin.	
6	JITTC	Input	—	Jitter detection capacitor connection pin.	
7	AIN	Input	—	A signal input pin.	
8	CIN	Input	—	C signal input pin.	
9	BIN	Input	—	B signal input pin.	
10	DIN	Input	—	D signal input pin.	
11	FEC	Output	—	FE signal LPF capacitor connection pin.	
12*	PHLPF/RFMON	Output	ZHI	Reference supply setting terminal.	
13	VREF	Output	AVDD1/2	VREF voltage output pin.	
14	EIN	Input	—	E signal input pin.	
15	FIN	Input	—	F signal input pin.	
16	TEC	Output	—	TE signal LPF capacitor connection pin.	
17	TE	Output	—	TE signal output pin.	
18	TEIN	Input	—	TES signal generation TE signal input pin	
19	LDD	Output	—	Laser power control signal output pin.	
20	LDS	Input	—	Laser power control signal input pin.	
21	FDO	Output	ADAVDD/2	Focus control output pin. D/A output.	
22	TDO	Output	ADAVDD/2	Tracking control output pin. D/A output.	
23	SLDO	Output	ADAVDD/2	Thread control output pin. D/A output.	
24	SPDO	Output	ADAVDD/2	Spindle control output pin. D/A output.	
25	AVSS2	—	—	Analog GND pin 2. Must always be connected to 0 V.	
26	AVDD2	Input	—	Analog power supply pin 2.	
27	DVDD	Input	—	Digital power supply pin.	
28	DVSS	—	—	Digital GND pin 2. Must always be connected to 0 V.	
29*	VPB	Output	H	Rough servo/phase control automatic switching monitor output pin. "H" for rough servo and "L" for phase servo.	
30	DEFECT	Output	L	Defect signal output pin.	
31*	FSEQ	Output	L	Synchronization signal detection output pin. Outputs a high level when the Synchronization signal detection from the EFM signal and the internally generated Synchronization signal agree.	
32*	EFLG	Output	L	C1, C2 error correction monitor pin	
33*	FSX	Output	L	7.35 kHz Synchronization signal output pin. CLV playback mode.	
34	CONT1	Input/Output	Input	General purpose I/O pin 1.	Controlled by command from the microprocessor. Any of these that are unused must be either set up as input pin ports and connected to 0 V, or set up as output pin ports and left open.
35	CONT2	Input/Output	Input	General purpose I/O pin 2.	
36	CONT3	Input/Output	Input	General purpose I/O pin 3.	
37*	MONI1	Input/Output	Input	External de-emphasis setting pin, Internal signal monitor pin 1. Controlled by microprocessor.	
38*	MONI2	Output	L	Internal signal monitor pin 2.	
39*	DOUT	Output	L	Digital OUT output Pin. (EIAJ format)	
40	TEST	Input	L	Test input pin. Must always be connected to 0 V.	
41	LVDD	Input	—	Left channel	L channel Power supply pin.
42	LCHO	Output	LVDD/2	D/A converter	L channel output supply pin.
43	LRVSS	—	—	LR channel GND pin. Must always be connected to 0 V.	

In this unit, the terminal with asterisk mark (*) is (open) terminal which is not connected to the outside.

CD-ES900/CD-ES99

IC1 VHiLC78648E-1: CD Digital Signal Processor (LC78648E) (2/2)

Pin No.	Terminal Name	Input/Output	Setting in Reset	Function	
44	RCHO	Output	RVDD /2	Right channel D/A converter	R channel Power supply pin.
45	RVDD	Input	—		R channel output supply pin.
46	XVSS	—	—	Digital GND pin. Must always be connected to 0 V	
47	XOUT	Output	Oscillator	Crystal oscillator	Power supply for crystal oscillator.
48	XIN	Input	Oscillator		Connected for a 16.9344 MHz crystal oscillator pin.
49	XVDD	Input	—	Digital power supply pin. Must always be connected to 0 V	
50	IOMODE	Input	—	CONT4 to 6. MONI3~5, DRF, WRQB pin output mode switching input pin. "L" setting: Normal output "H" setting: Nch open drain output	
51	F16MIN	Input	—	DF. DAC external clock input pin.	
52*	OUT1	Output	L	General-purpose output pin 1.	
53*	16MOUT	Output	CLK Output	16.9344 MHz output port.	
54	ASLRCK	Input	—	Anti-shock	Left/Right clock input pin. (Must be connect to 0 V when unused.)
55	ASDACK	Input	—		Bit clock input pin. (Must be connect to 0 V when unused.)
56	ASDFIN	Input	—		Left/Right channel data input pin. (Must be connect to 0 V when unused.)
57*	LRSK	Output	L	Digital data output	Left/Right channel data output pin.
58*	DATAACK	Output	L		Bit clock output pin.
59*	DATA	Output	L		Left/Right clock output pin.
60	DVDD	Input	—	Digital power supply pin.	
61	DVSS	—	—	Digital GND pin 2. Must always be connected to 0 V.	
62	CE	Input	—	Microcomputer Interface	Chip enable signal input pin.
63	CL	Input	—		Data transfer clock input pin.
64	DI	Input	—		Data output pin.
65	DO	Output	(H)		Data output pin. (Try state output.)
66	WRQB	Output	L	Interruption signal output pin.	
67	RESB	Input	—	Reset input pin for LSI. This pin must be set LOW briefly after power is first applied.	
68	DRF	Output	L	Focus ON detection pin.	
69	C2F/SBCK	Input/Output	Input	Error flag monitor pin, or sub code read clock input pin.	Controlled by commands from the micro- processor.
70	CONT6/SBCK	Input/Output	Input	General-purpose I/O pin 6, or sub code read clock input pin.	Controlled by commands from the micro- processor. Any of these that are unused must be either set up as input pin ports and connected to 0 V, or set up as output pin ports and left open.
71*	MONI5	Output	L	Internal signal monitor pin 5.	
72*	MONI4	Output	L	Internal signal monitor pin 4.	
73*	MONI3	Output	L	Internal signal monitor pin 3.	
74	CONT5	Input/Output	Input	General pur- pose I/O pin 5.	Controlled by command from the microprocessor. Any of these that are unused must be either set up as input pin ports and connected to 0 V, or set up as output pin ports and left open when unused.
75	CONT4	Input/Output	Input	General pur- pose I/O pin 4.	
76	PDO1	Output	—	PLL	Phase comparison output pin 1 to control built-in VCO.
77	PDO2	Output	—		Phase comparison output pin 2 to control built-in VCO.
78	PCKIST	Input	—		Resistor connection pin to set current for PDO1 and 02 out- puts.
79	VVSS	—	—		Built-in VCO GND pin. Must always be connected to 0 V.
80	VVDD	Input	—		Built-in VCO power supply pin.

In this unit, the terminal with asterisk mark (*) is (open) terminal which is not connected to the outside.

The same potential must be supplied to all power supply pins, i, e., AVDD1, AVDD2, XVDD, DVDD, LVDD and RVDD)

IC1 VHILC78648E-1: CD Digital Signal Processor(LC78648E)

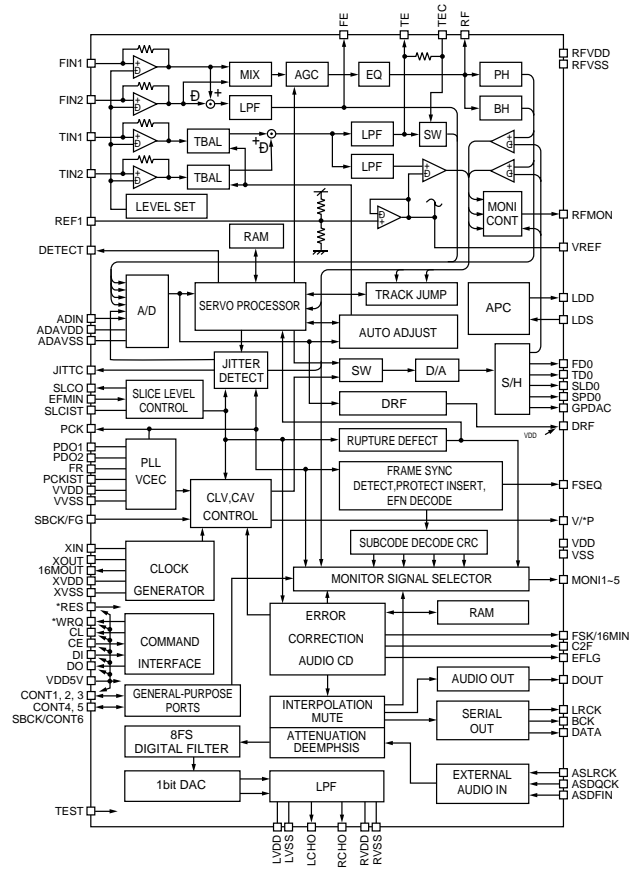
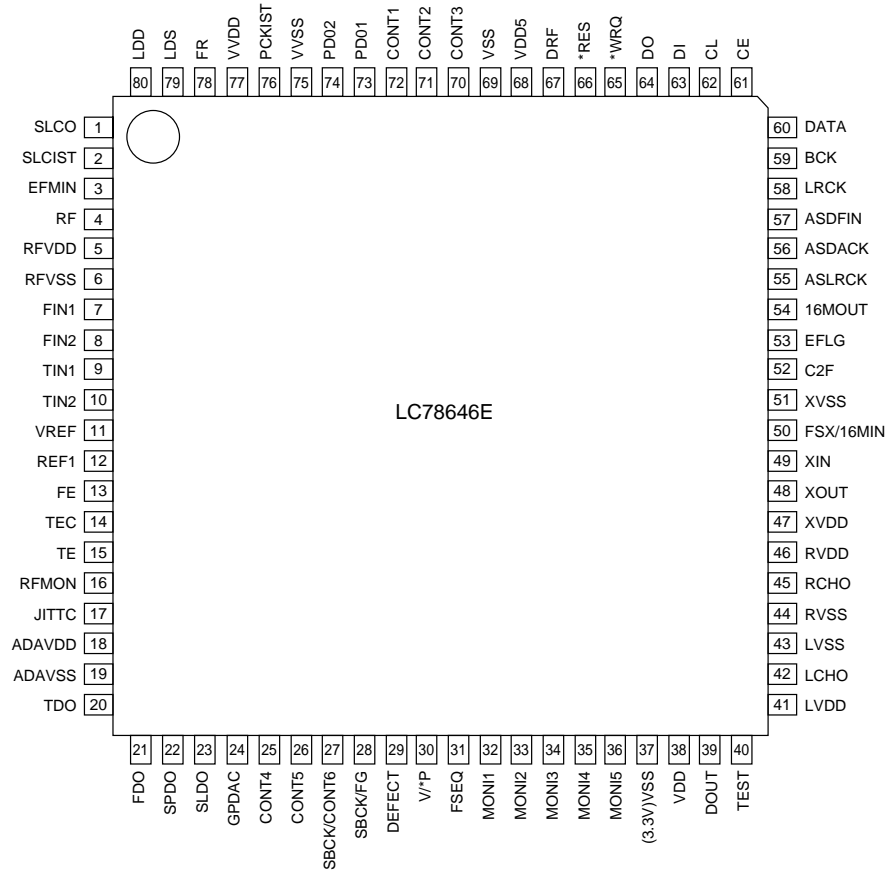

Figure 8-3 BLOCK DIAGRAM OF IC

CD-ES900/CD-ES99

IC2 VHiLA6261//1: Focus/Tracking/Spin/Sled Driver (LA6261)

Pin No.	Terminal Name	Function
1	VO3+	BTL Output pin (+) for channel 3.
2	VO3-	BTL Output pin (-) for channel 3.
3	VO2+	BTL Output pin (+) for channel 2.
4	VO2-	BTL Output pin (-) for channel 2.
5	VO1+	BTL Output pin (+) for channel 1.
6	VO1-	BTL Output pin (-) for channel 1.
7	PGND1	Power GND for channels 1, 2, 3 and 4 (BTL).
8	REGIN	Regulator pin (External PNP base).
9	PVCC1	Power for channels 1, 2, 3 and 4 (BTL). (SVCC short-circuited)
10	REGOUT	Regulator pin (External PNP collector).
11	VIN1	Input pin for channel 1.
12*	VIN1G	Input pin for channel 1 (for gain control).
13	VIN2	Input pin for channel 2.
14*	VIN2G	Input pin for channel 2 (for gain control).
15	VIN3	Input pin for channel 3.
16*	VIN3G	Input pin for channel 3 (for gain control).
17	VIN4	Input pin for channel 4.
18	VIN4G	Input pin for channel 4 (for gain control).
19	FWD5	CH5 Output change pin (FWD). Logic input for bridge.
20	REV5	CH5 Output change pin (REV). Logic input for bridge.
21	VCONT5	Input pin for CH5 output voltage control
22	FWD6	CH6 Output change pin (FWD). Logic input for bridge.
23	REV6	CH6 Output change pin (REV). Logic input for bridge.
24	VCONT6	Input pin for CH5 output voltage control.
25	VREFIN	Reference voltage input pin.
26	SGND	Signal system GND.
27	SVCC	Signal system power. (PVCC1 short - circuited)
28	PVCC2	Power for channel 5 and 6 (H bridge).
29	MUTE	Input pin for BTL mute.
30	PGND2	Power GND for channels 5 and 6 (H bridge).
31	VO6+	H bridge Output pin (+) for channel 6.
32	VO6-	H bridge Output pin (-) for channel 6.
33	VO5+	H bridge Output pin (+) for channel 5.
34	VO5-	H bridge Output pin (-) for channel 5.
35	VO4+	BTL Output pin (+) for channel 4.
36	VO4-	BTL Output pin (-) for channel 4.

In this unit, the terminal with asterisk mark (*) is (open) terminal which is not connected to the outside.

- * Set power system GND to the minimum potential together with SGND
- * Short-circuit three pins of power system SVSS and PVCC1 externally before use.

IC2 VHiLA6261// -1: Focus/Tracking/Spin/Sled Driver (LA6261)

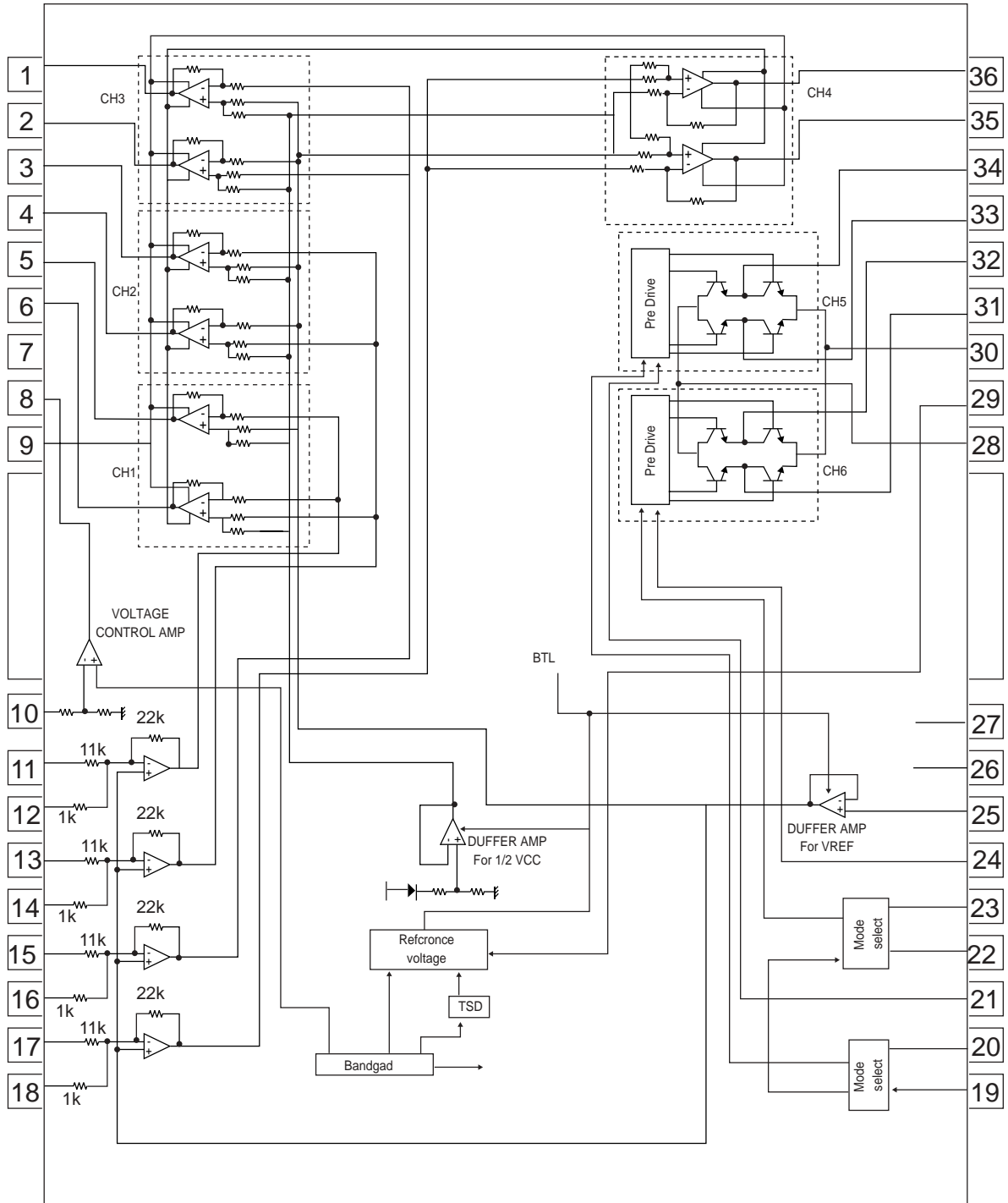

Figure 8-5 BLOCK DIAGRAM OF IC

IC601 VHI LC75341/-1: Audio Processor (LC75341)

Pin No.	Terminal Name	Function
1	DI	Serial data and clock input pin for control.
2	CE	Chip enable pin. Data written into an internal latch in a timing of "H" to "L". Each analog switch is activated. Data transfer enabled at "H" level.
3	VSS	Ground pin.
4	LOUT	Bass band filter comprising capacitor and resistor connection pin and bass/treble output pin.
5	LBASS	Bass band filter comprising capacitor and resistor connection pin.
6	LTRE	Treble band filter comprising capacitor and resistor connection pin.
7	LIN	Volume + equalizer output pin.
8	LSEL0	Input selector output pin.
9-12	L4-1	Input signal pin.
13-16	R1-4	Input signal pin.
17	RSEL0	Input selector output pin.
18	RIN	Volume + equalizer output pin
19	RTRE	Treble band filter comprising capacitor and resistor connection pin.
20	RBASS	Bass band filter comprising capacitor and resistor connection pin.
21	ROUT	Bass band filter comprising capacitor and resistor connection pin and bass/treble output pin.
22	VREF	0.5x VDD voltage generation block for analog ground. Capacitor of several 10 μF to be connected between VREF and AWSS (VSS) as a countermeasure against power ripple.
23	VDD	Supply pin
24	CLK	Serial data and clock input pin for control.

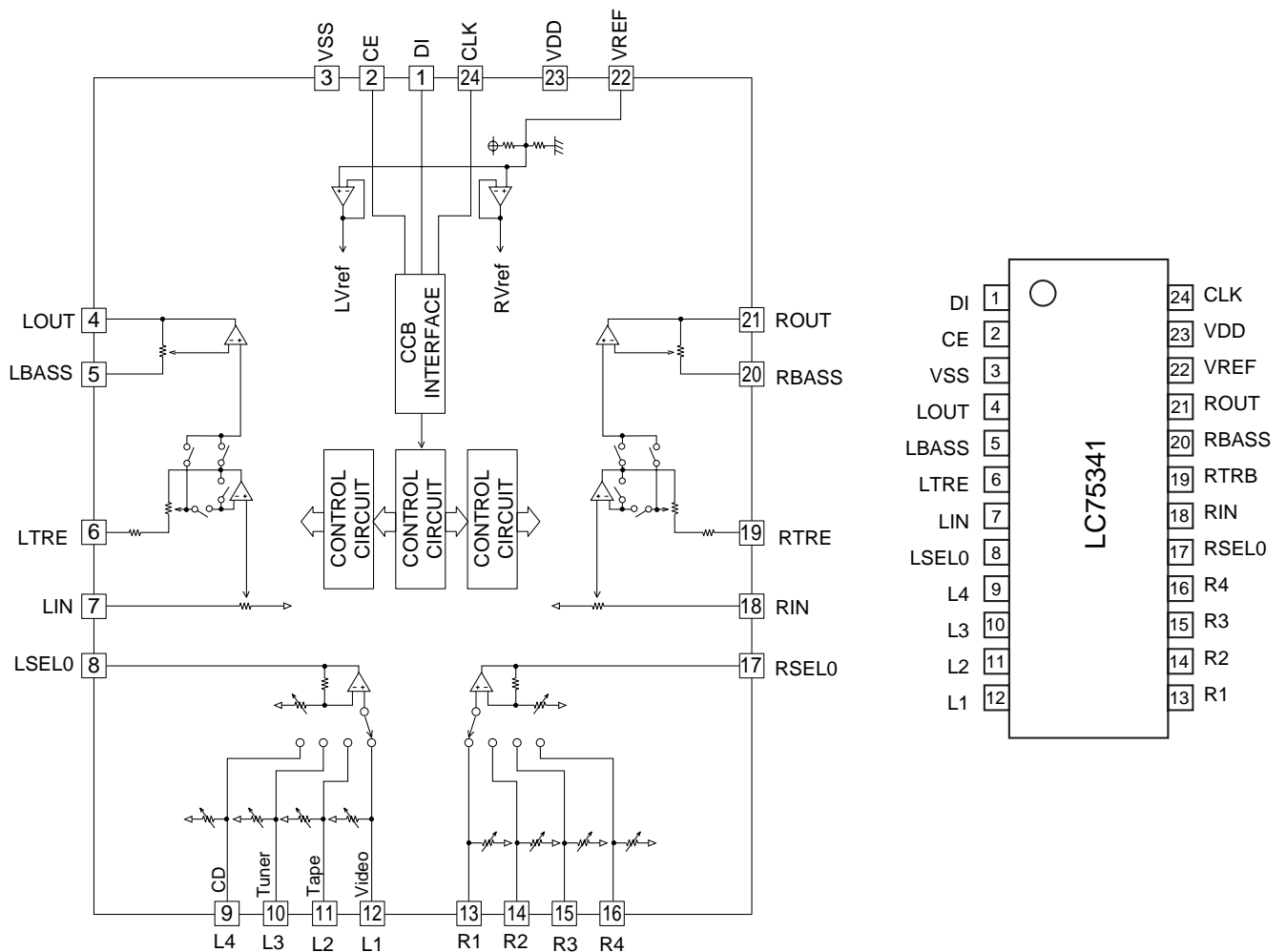

Figure 8-5 BLOCK DIAGRAM OF IC

IC701 RH-iXA002AWZZ: System Microcomputer (IXA002AW) (Serial No. 31000001~402XXXXX)

IC701 RH-iXA007AWZZ: System Microcomputer (IXA007AW) (Serial No. 402XXXXX)

IC701 RH-iXA020AWZZ: System Microcomputer (IXA020AW) (Serial No. 402XXXXX~)

Pin No.	Port Name	Terminal Name	Input/Output	Function
1	VDD	VDD	Input	Power supply 5 V.
2	P37	-20dBATT	Output	-20dB Attenuator.
3	P36	T BIAS	Output	Tape record bias control.
4	P35	T_REC/PLAY	Output	Tape REC/PLAY control.
5	P34	T_T1/T2	Output	Tape T1/T2 control.
6	P33	CD RESOUT	Output	CD reset.
7	P32	CD_WRQ	Input	CD WRQ input.
8*	P31	NO USE	Output	Open.
9*	P30	NO USE	Output	Open.
10	RESET	RESET	Input	Reset Input.
11	X2	XOUT	Output	Main clock output 4.19 MHz.
12	X1	XIN	Input	Main clock input 4.19 MHz.
13	IC (VPP)	VPP	—	GND
14*	XT2	NO USE	—	Open.
15	P04	CD_DRF	Input	CD DRF detect.
16	VDD	VDD	Input	Power supply 5 V.
17	P27	CLK	Output	Clock output.
18	P26	DI	Output	Data output.
19	P25	DO	Input	Data input.
20	P24	CE	Output	CE output.
21	P23	CD CE	Output	CD chip enable.
22	P22	CD CLK	Output	CD Clock.
23	P21	CD DI	Output	CD Data output.
24	P20	CD DO	Input	CD Data input.
25	AVSS	AVSS	—	Analog ground.
26	ANI7	T_RUN PULS	Input	Tape 1/2 Run Pulse detect.
27	ANI6	TUN_SM/SPAN	Input	Tuner signal meter/Span Selector.
28	ANI5	T_FP SW	Input	Tape Fool Proof A & B SW.
29	ANI4	PROTECT	Input	Power abnormal detect.
30	ANI3	VOL JOG	Input	Volume jog input.
31-33	ANI2-ANI0	KEY 2-KEY 0	Input	Key input.
34	AVDD	AVDD	Input	Analog power supply 5 V.
35	AVREF	AVREF	Input	Analog reference voltage 5 V.
36	INTP3	P_IN	Input	Power failure detect.
37	P02	PHOTO	Input	5-Changer Photo SW.
38	INTP1	SP_DET	Input	Speaker abnormal detect.
39	INTP0	REMOCON	Input	Remocon input.
40	VSS	VSS	—	Ground voltage.
41	P74	S MUTE	Output	System mute control.
42	P73	TIMER LED	Output	Timer LED control.
43	P72	T_SOL_B	Output	Tape 2 solenoid control.
44	P71	T_MOTOR	Output	Tape motor control.
45	P70	T_SOL_A	Output	Tape 1 solenoid control.
46	VDD	VDD	Input	Power supply 5 V.
47	P127	SP_RLY	Output	Speaker relay control.
48	P126	AC_RLY	Output	AC relay control.
49*	P125	RDS RST	Output	RDS reset.
50*	P124	RDS READY	Input	RDS ready.
51*	P123	RDS RDDA	Input	RDS data.
52*	P122	RDS RDCL	Output	RDS clock.
53	P121	TRAY SW2	Input	5-Changer Tray SW2.
54	P120	TRAY SW1	Input	5-Changer Tray SW1.
55	P117	DISC SW	Input	5-Changer Disc SW.
56	P116	CLAMP SW	Input	5-Changer Clamp SW.
57	P115	DIST	Input	Destination input.
58	P114	ILLU LED	Output	Illumination LED.
59*	P113	MIC SW	Input	Mic sw detect.
60*	P112	KARA_LATCH	Output	Karaoke latch.
61*	P111	NO USE	Output	Open.

In this unit, the terminal with asterisk mark (*) is (open) terminal which is not connected to the outside.

CD-ES900/CD-ES99

IC701 RH-iXA002AWZZ: System Microcomputer (IXA002AW) (Serial No. 31000001~402XXXXX)

IC701 RH-iXA007AWZZ: System Microcomputer (IXA007AW) (Serial No. 402XXXXX)

IC701 RH-iXA020AWZZ: System Microcomputer (IXA020AW) (Serial No. 402XXXXX~)

Pin No.	Port Name	Terminal Name	Input/Output	Function
62*	P110	NO USE	Output	Open.
63*	P107	NO USE	Output	Open.
64*	P106	NO USE	Output	Open.
65*	P105	NO USE	Output	Open.
66*	P104	NO USE	Output	Open.
67*	P103	NO USE	Output	Open.
68*	P102	NO USE	Output	Open.
69	P101/FIP30	S20/DEST0	Input	FL segment driver/Destination input.
70	P100/FIP29	S20/DEST1	Output	FL segment driver/Destination input.
71	P97/FIP28	S20/DEST2	Output	FL segment driver/Destination input.
72	P96/FIP27	S20/DEST3	Output	FL segment driver/Destination input.
73-78	FIP26-FIP21	S16-S11	Output	FL segment driver.
79	VLOAD	VLOAD	Input	VLOAD -35 V.
80-89	FIP20-FIP11	S10-S1	Output	FL segment driver.
90-100	FIP10-FIP0	G11-G1	Output	FL grid driver.

In this unit, the terminal with asterisk mark (*) is (open) terminal which is not connected to the outside.

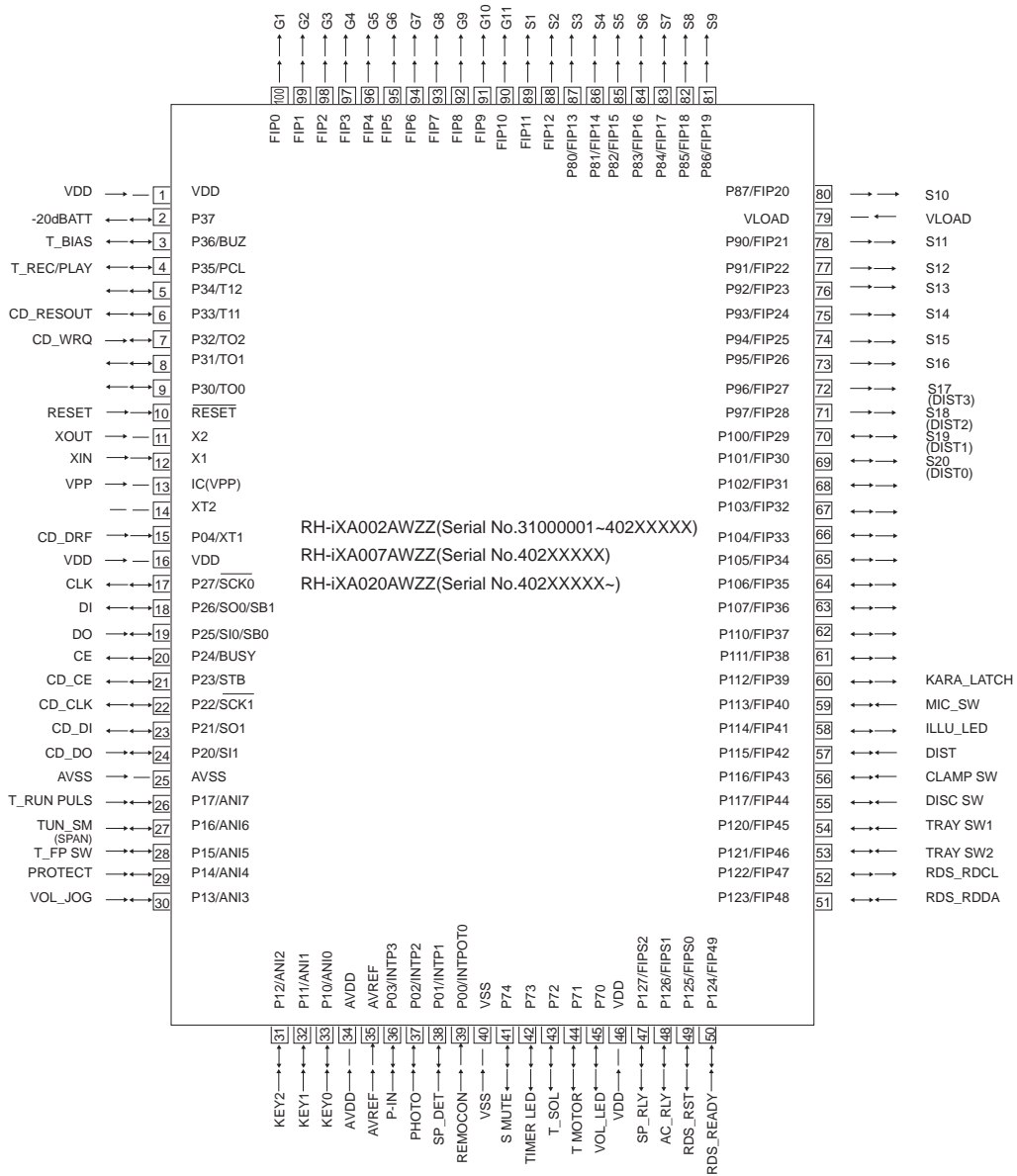

Figure 8-8 BLOCK DIAGRAM OF IC

IC851 VHiAN80T53/-1: Multi Regulator (AN80T53)

Pin No.	Terminal Name	Function
1	REG4 Output	5.1 V power supply with a minimum peak out current of 1200 mA.
2	REG3 Output	13 V power supply with a minimum peak out current of 1350 mA.
3	VCC	Connected to Power supplies.
4	GND	Connected to the IC substrate.
5	MODE 1	REG1, REG2, REG3 and REG4 outputs are turned ON when this pin is 5 V.
6	REG2 Output	10 V power supply with a minimum peak out current of 800 mA.
7	REG1 Output	8.5 V power supply with a minimum peak out current of 700 mA.

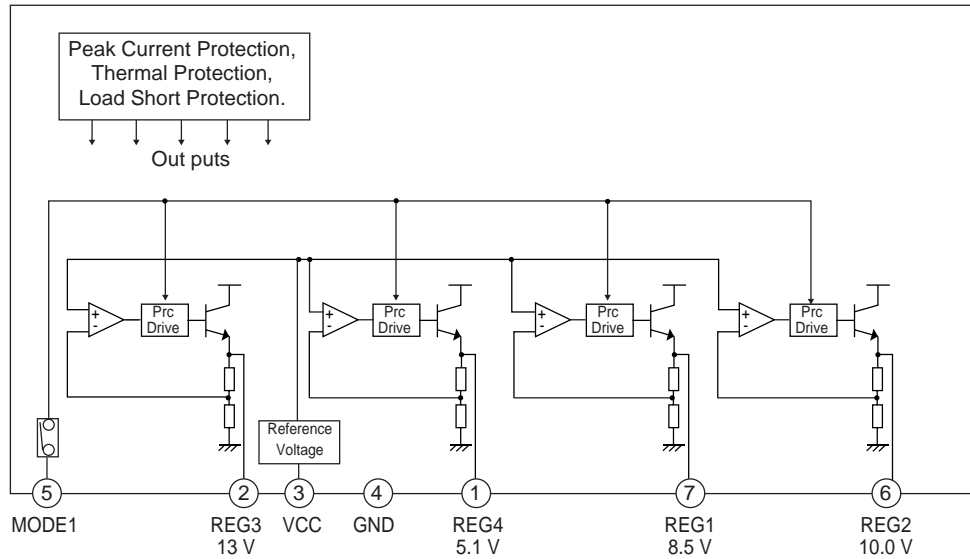

Figure 8-9 BLOCK DIAGRAM OF IC

[2] FL Display

FL701 VVKNA11SS55-1

GRID ASSIGNMENT

11G

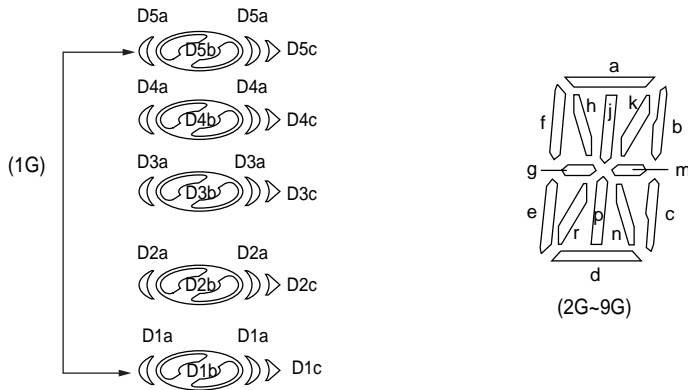
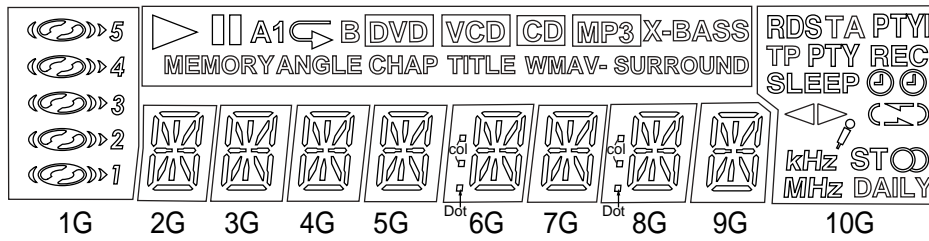

ANODE CONNECTION

	1G	2G	3G	4G	5G	6G	7G	8G	9G	10G	11G
P1	5	/	/	/	/	col	/	col	/	PTYI	DVD
P2	D5-a	a	a	a	a	a	a	a	a	(L)⊙	VCD
P3	D5-b	b	b	b	b	b	b	b	b	TA	CD
P4	D5-c	k	k	k	k	k	k	k	k	TP	X-BASS
P5	4	j	j	j	j	j	j	j	j	RDS	MP3
P6	D4-a	h	h	h	h	h	h	h	h	RES	WMA
P7	D4-b	f	f	f	f	f	f	f	f	▶	V-
P8	D4-c	m	m	m	m	m	m	m	m	◀	SURROUND
P9	3	d	d	d	d	d	d	d	d	DAILY	TITLE
P10	D3-a	g	g	g	g	g	g	g	g	PTY	CHAP
P11	D3-b	p	p	p	p	p	p	p	p)	ANGLE
P12	D3-c	e	e	e	e	e	e	e	e	(◀
P13	2	n	n	n	n	n	n	n	n	MHz	A
P14	D2-a	r	r	r	r	r	r	r	r	⊗	B
P15	D2-b	c	c	c	c	c	c	c	c	kHz	1
P16	D2-c	/	/	/	/	Dot	/	Dot	/	⊙	MEMORY
P17	1	/	/	/	/	/	/	/	/	ST	/
P18	D1-a	/	/	/	/	/	/	/	/	⊗	/
P19	D1-b	/	/	/	/	/	/	/	/	(R)⊙	▶
P20	D1-c	/	/	/	/	/	/	/	/	SLEEP	

OUTER DIMENSIONS



PIN CONNECTION

PIN NO.	45	44	43	42	41	40	39	38	37	36	35	34	33	32	31	30	29	28	27-22	21
CONNECTION	F2	F2	NP	NP	P20	P19	P18	P17	P16	P15	P14	P13	P12	P11	P10	P9	P8	P7	NX	P6

PIN NO.	20	19	18	17	16	15	14	13	12	11	10	9	8	7	6	5	4	3	2	1
CONNECTION	P5	P4	P3	P2	P1	11G	10G	9G	8G	7G	6G	5G	4G	3G	2G	1G	NP	NP	F1	F1

SHARP PARTS GUIDE

MINI COMPONENT SYSTEM

MODEL CD-ES900

CD-ES900 Mini Component System consisting of CD-ES900 (main unit) and CP-ES900 (speaker system).

MINI COMPONENT SYSTEM

MODEL CD-ES99

CD-ES99 Mini Component System consisting of CD-ES99 (main unit) and CP-ES99 (speaker system).

“HOW TO ORDER REPLACEMENT PARTS”

To have your order filled promptly and correctly, please furnish the following information.

- | | |
|-----------------|----------------|
| 1. MODEL NUMBER | 2. REF. No. |
| 3. PART NO. | 4. DESCRIPTION |

★ MARK: SPARE PARTS-DELIVERY SECTION

For U.S.A. only

Contact your nearest SHARP Parts Distributor to order.

For location of SHARP Parts Distributor,
Please call Toll-Free;
1-800-BE-SHARP

Explanation of capacitors/resistors parts codes

Capacitors

- VCC Ceramic type
- VCK Ceramic type
- VCT Semiconductor type
- VC •• MF Cylindrical type (without lead wire)
- VC •• MN Cylindrical type (without lead wire)
- VC •• TV Square type (without lead wire)
- VC •• TQ Square type (without lead wire)
- VC •• CY Square type (without lead wire)
- VC •• CZ Square type (without lead wire)
- VC J .. The 13th character represents capacity difference.
("J" ±5%, "K" ±10%, "M" ±20%, "N" ±30%,
"C" ±0.25 pF, "D" ±0.5 pF, "Z" +80-20%.)

If there are no indications for the electrolytic capacitors, error is ±20%.

Resistors

- VRD Carbon-film type
- VRS Carbon-film type
- VRN Metal-film type
- VR •• MF Cylindrical type (without lead wire)
- VR •• MN Cylindrical type (without lead wire)
- VR •• TV Square type (without lead wire)
- VR •• TQ Square type (without lead wire)
- VR •• CY Square type (without lead wire)
- VR •• CZ Square type (without lead wire)
- VR J .. The 13th character represents error.
("J" ±5%, "F" ±1%, "D" ±0.5%.)

If there are no indications for other parts, the resistors are ±5% carbon-film type.

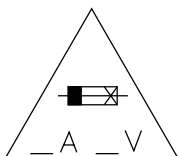

CAUTION:FOR CONTINUED PROTECTION AGAINST FIRE HAZARD, REPLACE ONLY WITH SAME TYPE F801, F802 5A, 125V / F803, F804 2A, 125V / F805 5A, 125V FUSES

ATTENTION:POUR ASSURER UNE LONGUE PROTECTION CONTRE UNINCENDIE, REMPLACER SEULEMENT PAR UN FUSIBLE DE TYPE F801, F802 5A, 125V / F803, F804 2A, 125V / F805 5A, 125V

NOTE:

Parts marked with “” are important for maintaining the safety of the set. Be sure to replace parts with specified ones for maintaining the safety and performance of the set.

CD-ES900/CD-ES99

NO.	PART CODE	★	PRICE RANK	DESCRIPTION
CD-ES900/CD-ES99				
INTEGRATED CIRCUITS				
IC1	VHILC78648E-1	J	AW	CD Servo,LC78648E
IC2	VHILA6261/-1	J	AN	Focus/Tracking/Spin/Sled Driver, LA6261
IC101	VHIAN7345K/-1	J	AM	Playback and Record/Playback Amp.,AN7345K
IC301	VHITA7358AP-1	J	AG	FM Front End,TA7358AP
IC302	VHILC72131/-1	J	AP	PLL (Tuner),LC72131
IC303	VHILA1832S/-1	J	AN	FM IF Det./FM Mpx./AM IF, LA1832S
IC601	VHILC75341/-1	J	AM	Audio Processor,LC75341
IC701	RH-IXA002AWZZ	J	AX	System Microcomputer, IXA002AW (Serial No. 3100000 ~ 402XXXXX)
IC701	RH-IXA007AWZZ	J		System Microcomputer, IXA007AW (Serial No. 402XXXXX)
IC701	RH-IXA020AWZZ	J		System Microcomputer, IXA020AW (Serial No. 402XXXXX ~)
IC851	VHIAN80T53/-1	J	AL	Multi Regulator,AN80T53
IC854	VHIAN78L05/-1	J	AE	Voltage Regulator,AN78L05
IC901	VHISTK41244-1	J	BF	Power Amp.,STK41244
TRANSISTORS				
Q1	VSKTA1504Y/-1	J	AB	Silicon,PNP,KTA1504 Y
Q2	VSKTA1271Y/-1	J	AC	Silicon,PNP,KTA1271 Y
Q101~104	VSKTC3200GR-1	J	AC	Silicon,NPN,KTC3200 GR
Q105~108	VSKTC3875GR-1	J	AB	Silicon,NPN,KTC3875 GR
Q109	VSKTA1504Y/-1	J	AB	Silicon,PNP,KTA1504 Y
Q110	VSKRC104S/-1	J	AC	Digital,NPN,KRC104 S
Q111	VSKTC3203Y/-1	J	AC	Silicon,NPN,KTC3203 Y
Q112	VSKTA1504Y/-1	J	AB	Silicon,PNP,KTA1504 Y
Q113,114	VSKRC104S/-1	J	AC	Digital,NPN,KRC104 S
Q302	VSKTC3194Y/-1	J	AD	Silicon,NPN,KTC3194 Y
Q360	VSKTA1266GR-1	J	AB	Silicon,PNP,KTA1266 GR
Q601~604	VSKTC3875GR-1	J	AB	Silicon,NPN,KTC3875 GR
Q706~708	VSKTA1273Y/-1	J	AE	Silicon,PNP,KTA1273 Y
Q709,710	VSKRC102S/-1	J	AB	Digital,NPN,KRC102 S
Q711	VSKRA107S/-1	J	AB	Digital,NPN,KRA107 S
Q712~714	VSKRC104S/-1	J	AC	Digital,NPN,KRC104 S
Q715	VSKRA107S/-1	J	AB	Digital,NPN,KRA107 S
Q716	VSKRC104S/-1	J	AC	Digital,NPN,KRC104 S
Q717	VSKRA107S/-1	J	AB	Digital,NPN,KRA107 S
Q801	VSKTA1274Y/-1	J	AE	Silicon,PNP,KTA1274 Y
Q841	VSKTC3199GR-1	J	AB	Silicon,NPN,KTC3199 GR
Q885,886	VSKTC3875GR-1	J	AB	Silicon,NPN,KTC3875 GR
Q901~904	VSKTC3875GR-1	J	AB	Silicon,NPN,KTC3875 GR
Q905	VSKTC3199GR-1	J	AB	Silicon,NPN,KTC3199 GR
Q906,907	VSKTC3203Y/-1	J	AC	Silicon,NPN,KTC3203 Y
Q908,909	VSKTC3875GR-1	J	AB	Silicon,NPN,KTC3875 GR
DIODES				
D1	VHDKDS184/-1	J	AB	Silicon,KDS184
D301,302	VHDDS1SS133-1	J	AB	Silicon,DS1SS133
D305	VHDDS1SS133-1	J	AB	Silicon,DS1SS133
D690,691	VHDDS1SS133-1	J	AB	Silicon,DS1SS133
D701	VHDDS1SS133-1	J	AB	Silicon,DS1SS133
D709~716	VHDDS1SS133-1	J	AB	Silicon,DS1SS133
D801,802	VHDD10XB60F-1	J	AL	Silicon,D10XB60F
D803~806	VHD1N4004S/-1	J	AB	Silicon,1N4004S
D842~845	VHD1N4004S/-1	J	AB	Silicon,1N4004S
△ D846	VHDDS1SS133-1	J	AB	Silicon,DS1SS133
D853	VHD1N4004S/-1	J	AB	Silicon,1N4004S
D856	VHDDS1SS133-1	J	AB	Silicon,DS1SS133
D860~863	VHDDS1SS133-1	J	AB	Silicon,DS1SS133
D885	VHDDS1SS133-1	J	AB	Silicon,DS1SS133
D905~907	VHDDS1SS133-1	J	AB	Silicon,DS1SS133
D909,910	VHD1N4004S/-1	J	AB	Silicon,1N4004S
D911~914	VHDDS1SS133-1	J	AB	Silicon,DS1SS133
LED701	VHP304VT2H3-1	J	AC	LED,Red,304VT2H3
LED703	VHPSDPB50CD-1	J	AK	LED,Blue,SDPB50CD
ZD1	VHEDZ3R3BSB-1	J	AB	Zener,3.3V,DZ3.3BSB
ZD351	VHEDZ5R1BSB-1	J	AC	Zener,5.1V,DZ5.1BSB
ZD801	VHEDZ6R2BSA-1	J	AB	Zener,6.2V,DZ6.2BSA

NO.	PARTS CODE	★	PRICE RANK	DESCRIPTION
ZD802	VHEDZ7R5BSB-1	J	AB	Zener,7.5V,DZ7.5BSB
ZD803	VHEDZ300BSB-1	J	AB	Zener,30V,DZ30BSB
ZD805	VHEDZ120BSB-1	J	AB	Zener,12V,DZ12BSB
ZD902,903	VHEDZ120BSB-1	J	AB	Zener,12V,DZ12BSB
FILTERS				
BF301	RFILR0008AWZZ	J	AE	Band Pass Filter
CF303	RFILF0124AFZZ	J	AD	FM IF,10.7 MHz
CF351	RFILF0003AWZZ	J	AK	FM IF
CF352	RFILA0009AWZZ	J	AE	AM IF
TRANSFORMERS				
△ PT801	RTRNP0518AWZZ	J	BL	Power,Main
△ PT841	RTRNP0483AWZZ	J	AL	Power,Sub
T301	RCILB0065AWZZ	J	AC	FM OSC.
T302	RCIL0017AWZZ	J	AB	FM IF
T303	RCILA0052AWZZ	J	AE	AM Antenna
T306	RCILB0067AWZZ	J	AD	AM OSC.
T351	RCIL0019AWZZ	J	AD	AM IF
COILS				
L1	VP-XHR82K0000	J	AC	0.82 μH
L103	VP-MK331K0000	J	AB	330 μH,Choke
L312	RCILR0056AWZZ	J	AB	FM RF
L351,352	VP-DH101K0000	J	AB	100 μH,Choke
L701	VP-DH101K0000	J	AB	100 μH,Choke
L901,902	RCILZ0024AWZZ	J	AC	3 μH,Choke
L920,921	RCILZ0137AFZZ	J	AA	0.29 μH
VARIABLE CAPACITORS				
VD301	VHCSVC347S/-1	J	AG	Variable Capacitance,SVC347S
VD302,303	VHCSVC230C/-1	J	AD	Variable Capacitance,SVC230C
VIBRATORS				
X351	92LCRSTL1425A	J	AF	Crystal,456 kHz
X352	RCRSP0019AWZZ	J	AF	Crystal,4.5 MHz
XL1	RCRSP0020AWZZ	J	AG	Crystal,16.9344 MHz
XL701	RCRSP0003AWZZ	J	AH	Crystal,4.19 MHz
CAPACITORS				
C1	VCEAZA1EW476M	J	AB	47 μF,25V,Electrolytic
C2	VCKYCY1CB103K	J	AA	0.01 μF,16V
C3	VCEAZA1EW476M	J	AB	47 μF,25V,Electrolytic
C4	VCKYCY1HB102K	J	AA	0.001 μF,50V
C5	VCKYCY1HB473K	J	AB	0.047 μF,50V
C6	VCKYCY1CB103K	J	AA	0.01 μF,16V
C8	VCKYCY1HB272K	J	AA	0.0027 μF,50V
C9	RC-EZ0004AWZZ	J	AD	3.3 μF,16V,Electrolytic
C10	VCKYCY1HB102K	J	AA	0.001 μF,50V
C11	VCTYPA1CX563K	J	AB	0.056 μF,16V
C12	VCCCCY1HH101J	J	AA	100 pF (CH),50V
C13	VCKYCY1EF223Z	J	AB	0.022 μF,25V
C14,15	VCEAZA1AW107M	J	AB	100 μF,10V,Electrolytic
C16	VCEAZA0JW337M	J	AC	330 μF,6.3V,Electrolytic
C17	VCKYCY1HB102K	J	AA	0.001 μF,50V
C18	VCKYPA1HF103Z	J	AB	0.01 μF,50V
C20	VCEAZA1AW107M	J	AB	100 μF,10V,Electrolytic
C21	VCKYCY1CB563K	J	AB	0.056 μF,16V
C22	VCKYCY1CB103K	J	AA	0.01 μF,16V
C23,24	VCEAZA1EW106M	J	AB	10 μF,25V,Electrolytic
C25,26	VCQYKA1HM152K	J	AB	0.0015 μF,50V,MyIar
C27	VCKYCY1EF223Z	J	AB	0.022 μF,25V
C28~32	VCCCCY1HH101J	J	AA	100 pF (CH),50V
C33	VCKYCY1EF223Z	J	AB	0.022 μF,25V
C34	VCCCCY1HH101J	J	AA	100 pF (CH),50V
C35	VCKYCY1HB473K	J	AB	0.047 μF,50V
C36	VCKYCY1CF224Z	J	AB	0.22 μF,16V
C37	VCKYCY1CB104K	J	AB	0.1 μF,16V
C38	VCKYCY1CB103K	J	AA	0.01 μF,16V
C39,40	VCEAZA1AW107M	J	AB	100 μF,10V,Electrolytic
C42	VCKYPA1HF103Z	J	AB	0.01 μF,50V
C43	VCKYCY1EF223Z	J	AB	0.022 μF,25V
C44	VCKYCY1HB102K	J	AA	0.001 μF,50V

NO.	PART CODE	★ PRICE RANK	DESCRIPTION	NO.	PARTS CODE	★ PRICE RANK	DESCRIPTION
C46	VCKYCY1CB103K	J AA	0.01 μF,16V	C386	VCKYCY1HB331K	J AA	330 pF,50V
C47	VCEAZA1AW107M	J AB	100 μF,10V,Electrolytic	C387	VCKYCY1EF223Z	J AB	0.022 μF,25V
C48,49	VCKYCY1EF223Z	J AB	0.022 μF,25V	C388	VCKYCY1HB102K	J AA	0.001 μF,50V
C50	VCKYPA1HF223Z	J AB	0.022 μF,50V	C389	VCKYBT1HB102K	J AA	0.001 μF,50V
C51,52	VCCCCY1HH180J	J AA	18 pF (CH),50V	C391	VCEAZA1EW476M	J AB	47 μF,25V,Electrolytic
C101,102	VCKYCY1HB561K	J AA	560 pF,50V	C392	VCKYCY1HB102K	J AA	0.001 μF,50V
C103	VCKYBT1HB181K	J AA	180 pF,50V	C393	VCEAZA1HW105M	J AB	1 μF,50V,Electrolytic
C104	VCCCCY1HH181J	J AA	180 pF (CH),50V	C394	VCEAZA1EW476M	J AB	47 μF,25V,Electrolytic
C105,106	VCKYCY1HB152K	J AA	0.0015 μF,50V	C395	VCKYCY1EF223Z	J AB	0.022 μF,25V
C107~110	VCKYCY1HB331K	J AA	330 pF,50V	C396	VCEAZA1AW107M	J AB	100 μF,10V,Electrolytic
C111,112	VCEAZA1EW476M	J AB	47 μF,25V,Electrolytic	C397	VCKYCY1EF223Z	J AB	0.022 μF,25V
C113,114	VCTYPA1EX393K	J AA	0.039 μF,25V	C398	VCEAZA1AW107M	J AB	100 μF,10V,Electrolytic
C115,116	VCKYCY1HB561K	J AA	560 pF,50V	C399	VCKYCY1EF223Z	J AB	0.022 μF,25V
C117,118	VCEAZA1EW476M	J AB	47 μF,25V,Electrolytic	C601	VCEAZA1CW227M	J AC	220 μF,16V,Electrolytic
C119,120	VCKYCY1HB222K	J AA	0.0022 μF,50V	C602	VCKYPA1HF223Z	J AB	0.022 μF,50V
C121	VCKYCY1EF223Z	J AB	0.022 μF,25V	C603	VCEAZA1AW227M	J AC	220 μF,10V,Electrolytic
C123,124	VCKYCY1HB271K	J AA	270 pF,50V	C605,606	VCFYFA1HA104J	J AC	0.1 μF,50V,Thin Film
C125,126	VCEAZA1HW226M	J AB	22 μF,50V,Electrolytic	C607,608	VCFYFA1HA823J	J	0.082 μF,50V
C127,128	VCTYPA1CX223K	J AA	0.022 μF,16V	C609,610	VCEAZA1HW105M	J AB	1 μF,50V,Electrolytic
C129,130	VCKYCY1HB332K	J AA	0.0033 μF,50V	C611,612	VCKYCY1HB222K	J AA	0.0022 μF,50V
C131,132	VCEAZA1EW476M	J AB	47 μF,25V,Electrolytic	C613,614	VCEAZA1HW105M	J AB	1 μF,50V,Electrolytic
C133	VCEAZA1EW226M	J AB	22 μF,25V,Electrolytic	C615,616	VCEAZA1HW475M	J AB	4.7 μF,50V,Electrolytic
C134	VCEAZA1AW227M	J AC	220 μF,10V,Electrolytic	C617~624	VCEAZA1HW105M	J AB	1 μF,50V,Electrolytic
C135	VCKYCY1EF223Z	J AB	0.022 μF,25V	C625,626	VCKYCY1HB222K	J AA	0.0022 μF,50V
C137	VCQYKA1HM473K	J AB	0.047 μF,50V,Mylar	C631	VCKYBT1HB103K	J AB	0.01 μF,50V
C138	VCQPKA2AA822J	J AA	0.0082 μF,100V,Polypropylene	C639	VCEAZA1HW105M	J AB	1 μF,50V,Electrolytic
C139	VCQYKA1HM393K	J AB	0.039 μF,50V,Mylar	C640	VCEAZA1HW226M	J AB	22 μF,50V,Electrolytic
C140	VCEAZA1EW476M	J AB	47 μF,25V,Electrolytic	C651~653	VCKYCY1HB221K	J AA	220 pF,50V
C141	VCEAZA1CW107M	J AC	100 μF,16V,Electrolytic	C690,691	VCKYPA1HB391K	J AA	390 pF,50V
C143	VCEAZA1HW335M	J AB	3.3 μF,50V,Electrolytic	C701	VCEAZA1HW105M	J AB	1 μF,50V,Electrolytic
C150	VCEAZA1HW476M	J AB	47 μF,50V,Electrolytic	C702	VCEAZA1AW227M	J AC	220 μF,10V,Electrolytic
C302	VCKYCY1HB102K	J AA	0.001 μF,50V	C704	VCCCCY1HH150J	J AA	15 pF (CH),50V
C303	VCCCCY1HH100D	J AA	10 pF (CH),50V	C705	VCCCCY1HH180J	J AA	18 pF (CH),50V
C304	VCKYCY1HB103K	J AA	0.01 μF,50V	C707	VCEAZA1HW105M	J AB	1 μF,50V,Electrolytic
C305	VCCCCY1HH4R7C	J AA	4.7 pF (CH),50V	C709,710	VCKYCY1HB473K	J AB	0.047 μF,50V
C306	VCKYCY1EF223Z	J AB	0.022 μF,25V	C714	VCEAZA1HW335M	J AB	3.3 μF,50V,Electrolytic
C307	VCEAZA1HW106M	J AB	10 μF,50V,Electrolytic	C715	VCKYCY1HB103K	J AA	0.01 μF,50V
C308	VCCCCY1HH4R7C	J AA	4.7 pF (CH),50V	C717	VCEAZA1EW476M	J AB	47 μF,25V,Electrolytic
C309	VCKYCY1HB102K	J AA	0.001 μF,50V	C720,721	VCKYCY1EF223Z	J AB	0.022 μF,25V
C310	VCCCCY1HH150J	J AA	15 pF (CH),50V	C722	VCKYPA1HF103Z	J AB	0.01 μF,50V
C311	VCCCCY1HH180J	J AA	18 pF (CH),50V	C801	VCEAZA1VW107M	J AC	100 μF,35V,Electrolytic
C312	VCKYCY1EF223Z	J AB	0.022 μF,25V	C802,803	VCEAZA1HW476M	J AB	47 μF,50V,Electrolytic
C313	VCCCCY1HH220J	J AA	22 pF (CH),50V	C804	VCEAZA1JW227M	J AD	220 μF,63V,Electrolytic
C315	VCKYCY1HB103K	J AA	0.01 μF,50V	C805	VCEAZA2AW226M	J AC	22 μF,100V,Electrolytic
C316	VCKYCY1EF223Z	J AB	0.022 μF,25V	C806~809	VCQYKA1HM104K	J AB	0.1 μF,50V,Mylar
C317	VCKYCY1HB102K	J AA	0.001 μF,50V	C810,811	VCFYDA2AA224J	J AD	0.22 μF,100V,Thin Film
C318	VCKYBT1HB101K	J AA	100 pF,50V	C841	VCEAZA0JW108M	J AC	1000 μF,6.3V,Electrolytic
C320	VCKYBT1HB102K	J AA	0.001 μF,50V	C842	VCEAZA1VW477M	J AD	470 μF,35V,Electrolytic
C323	VCKYCY1EF223Z	J AB	0.022 μF,25V	C843	VCQYKA1HM473K	J AB	0.047 μF,50V,Mylar
C324	VCCCCY1HH4R7C	J AA	4.7 pF (CH),50V	△C844	RC-KZ002LAWZZ	J AC	0.0047 μF,250V,Ceramic
C330	VCCCCY1HH150J	J AA	15 pF (CH),50V	C850	VCEAZW1EW478M	J AK	4700 μF,25V,Electrolytic
C331	VCKZPA1HF473Z	J AA	0.047 μF,50V	C854	VCEAZA1EW227M	J AC	220 μF,25V,Electrolytic
C332	VCKYCY1EF223Z	J AB	0.022 μF,25V	C855	VCEAZA1HW106M	J AB	10 μF,50V,Electrolytic
C334	VCCCCY1HH220J	J AA	22 pF (CH),50V	C856	VCQYKA1HM104K	J AB	0.1 μF,50V,Mylar
C335	VCKYCY1HB561K	J AA	560 pF,50V	C859	VCEAZA1HW226M	J AB	22 μF,50V,Electrolytic
C338	VCKYCY1HB102K	J AA	0.001 μF,50V	C861	VCKYPA1HF223Z	J AB	0.022 μF,50V
C342	VCKYCY1EF223Z	J AB	0.022 μF,25V	C864,865	VCEAZA1EW226M	J AB	22 μF,25V,Electrolytic
C347	VCKYCY1EF223Z	J AB	0.022 μF,25V	C885	VCKYCY1HB104K	J AD	0.1 μF,50V
C350,351	VCKYCY1EF223Z	J AB	0.022 μF,25V	C901,902	VCEAZA1HW225M	J AB	2.2 μF,50V,Electrolytic
C352	VCEAZA1HW106M	J AB	10 μF,50V,Electrolytic	C903,904	VCKYCY1HB102K	J AA	0.001 μF,50V
C353,354	VCKYCY1HF223Z	J AB	0.022 μF,25V	C905,906	VCEAZA1HW476M	J AB	47 μF,50V,Electrolytic
C355	VCCCCY1HH220J	J AA	22 pF (CH),50V	C907	VCCCCY1HH101J	J AA	100 pF (CH),50V
C356	VCKYCY1HB102K	J AA	0.001 μF,50V	C908	VCCCCY1HH3R0C	J AA	3 pF (CH),50V
C357	VCEAZA1HW225M	J AB	2.2 μF,50V,Electrolytic	C909	VCQYKA1HM104K	J AB	0.1 μF,50V,Mylar
C358	VCEAZA1HW105M	J AB	1 μF,50V,Electrolytic	C910	VCCCCY1HH3R0C	J AA	3 pF (CH),50V
C361	VCKYCY1EF223Z	J AB	0.022 μF,25V	C911,912	VCEAZA2AW107M	J AD	100 μF,100V,Electrolytic
C362	VCEAZA1HW335M	J AB	3.3 μF,50V,Electrolytic	C913	VCCCCY1HH101J	J AA	100 pF (CH),50V
C363	VCKYCY1EF223Z	J AB	0.022 μF,25V	C914,915	VCEAZA2AW107M	J AD	100 μF,100V,Electrolytic
C364	VCEAZA1HW225M	J AB	2.2 μF,50V,Electrolytic	C916	VCEAZA1HW107M	J AC	100 μF,50V,Electrolytic
C365	VCTYPA1CX223K	J AA	0.022 μF,16V	C917	VCKYCY1HB103K	J AA	0.01 μF,50V
C366	VCKYCY1HB102K	J AA	0.001 μF,50V	C918	VCEAZA1HW107M	J AC	100 μF,50V,Electrolytic
C367,368	VCEAZA1HW105M	J AB	1 μF,50V,Electrolytic	C919	VCKYCY1HB103K	J AA	0.01 μF,50V
C369	VCCCCY1HH270J	J AA	27 pF (CH),50V	C920	RC-EZ0124AWZZ	J AN	3900 μF,85V,Electrolytic
C370~372	VCEAZA1HW105M	J AB	1 μF,50V,Electrolytic	C921,922	RC-EZ006SAWZZ	J AN	4700 μF,50V,Electrolytic
C373,374	VCTYPA1CX153K	J AA	0.015 μF,16V	C923	RC-EZ0124AWZZ	J AN	3900 μF,85V,Electrolytic
C376~379	VCCCCY1HH101J	J AA	100 pF (CH),50V	C925	VCEAZA1HW476M	J AB	47 μF,50V,Electrolytic
C380	VCEAZA1HW106M	J AB	10 μF,50V,Electrolytic	C928,929	VCQYKA1HM104K	J AB	0.1 μF,50V,Mylar
C381	VCCCCY1HH120J	J AA	12 pF (CH),50V	C931	VCEAZA1HW106M	J AB	10 μF,50V,Electrolytic
C382	VCCCCY1HH150J	J AA	15 pF (CH),50V	C944	VCEAZA1AW476M	J AB	47 μF,10V,Electrolytic
C383	VCCSBT1HL470J	J AA	47 pF,50V	C946	VCEAZA1HW104M	J AB	0.1 μF,50V,Electrolytic
C384	VCKYCY1HB102K	J AA	0.001 μF,50V	CT1	VCKZPA1HF473Z	J AA	0.047 μF,50V
C385	VCKYCY1HB103K	J AA	0.01 μF,50V				

CD-ES900/CD-ES99

NO.	PART CODE	★ PRICE RANK	DESCRIPTION	NO.	PARTS CODE	★ PRICE RANK	DESCRIPTION
RESISTORS							
	VRS-CY1JB000J	J AA	0 ohm, Jumper, 0.8x1.55mm, Green	R355	VRS-CY1JB332J	J AA	3.3 kohms, 1/16W
R3	VRD-ST2CD563J	J AA	56 kohms, 1/6W	R356	VRS-CY1JB102J	J AA	1 kohm, 1/16W
R6	VRD-ST2CD563J	J AA	56 kohms, 1/6W	R357	VRS-CY1JB474J	J AA	470 kohms, 1/16W
R7	VRD-ST2CD470J	J AA	47 ohms, 1/6W	R358	VRD-ST2CD392J	J AA	3.9 kohms, 1/6W
R8	VRD-ST2CD103J	J AA	10 kohm, 1/6W	R359	VRS-CY1JB182J	J AA	1.8 kohms, 1/16W
R9	VRS-CY1JB100J	J AA	10 ohm, 1/16W	R360	VRS-CY1JB472J	J AA	4.7 kohms, 1/16W
R10	VRD-ST2CD103J	J AA	10 kohm, 1/6W	R365	VRS-CY1JB103J	J AA	10 kohm, 1/16W
R12	VRS-CY1JB331J	J AA	330 ohms, 1/16W	R372-374	VRS-CY1JB102J	J AA	1 kohm, 1/16W
R13	VRD-ST2CD822J	J AA	8.2 kohms, 1/6W	R375	VRD-ST2CD471J	J AA	470 ohms, 1/6W
R14,15	VRD-ST2CD682J	J AA	6.8 kohms, 1/6W	R376	VRS-CY1JB102J	J AA	1 kohm, 1/16W
R16	VRD-ST2CD153J	J AA	15 kohms, 1/6W	R377	VRS-CY1JB473J	J AA	47 kohms, 1/16W
R17	VRS-CY1JB682J	J AA	6.8 kohms, 1/16W	R378	VRS-CY1JB102J	J AA	1 kohm, 1/16W
R18	VRD-ST2CD102J	J AA	1 kohm, 1/6W	R379	VRS-CY1JB222J	J AA	2.2 kohms, 1/16W
R19	VRS-CY1JB562J	J AA	5.6 kohms, 1/16W	R380	VRS-CY1JB152J	J AA	1.5 kohms, 1/16W
R20	VRD-ST2CD472J	J AA	4.7 kohms, 1/6W	R381	VRS-CY1JB103J	J AA	10 kohm, 1/16W
R21	VRS-CY1JB472J	J AA	4.7 kohms, 1/16W	R382	VRD-ST2EE151J	J AA	150 ohms, 1/4W
R22	VRD-ST2CD101J	J AA	100 ohm, 1/6W	R383	VRS-CY1JB562J	J AA	5.6 kohms, 1/16W
R24,25	VRS-CY1JB222J	J AA	2.2 kohms, 1/16W	R384	VRD-ST2CD562J	J AA	5.6 kohms, 1/6W
R26,27	VRS-CY1JB103J	J AA	10 kohm, 1/16W	R385	VRS-CY1JB562J	J AA	5.6 kohms, 1/16W
R28	VRD-ST2CD222J	J AA	2.2 kohms, 1/6W	R386	VRD-ST2CD223J	J AA	22 kohms, 1/6W
R30,31	VRD-ST2CD222J	J AA	2.2 kohms, 1/6W	R387	VRD-ST2CD562J	J AA	5.6 kohms, 1/6W
R32-38	VRD-ST2CD102J	J AA	1 kohm, 1/6W	R388	VRS-CY1JB392J	J AA	3.9 kohms, 1/16W
R39,40	VRS-CY1JB681J	J AA	680 ohms, 1/16W	R391,392	VRD-ST2EE271J	J AA	270 ohms, 1/4W
R41	VRS-CY1JB563J	J AA	56 kohms, 1/16W	R393	VRD-ST2CD102J	J AA	1 kohm, 1/6W
R42	VRD-ST2EE1R0J	J AA	1 ohm, 1/4W	R395	VRS-CY1JB473J	J AA	47 kohms, 1/16W
R43	VRS-CY1JB221J	J AA	220 ohms, 1/16W	R573	VRD-ST2CD103J	J AA	10 kohm, 1/6W
R44	VRD-ST2EE1R0J	J AA	1 ohm, 1/4W	R593	VRS-CY1JB103J	J AA	10 kohm, 1/16W
R45	VRD-ST2CD101J	J AA	100 ohm, 1/6W	R601-603	VRD-ST2CD102J	J AA	1 kohm, 1/6W
R47	VRD-ST2CD222J	J AA	2.2 kohms, 1/6W	R604,605	VRS-CY1JB103J	J AA	10 kohm, 1/16W
R48,49	VRS-CY1JB103J	J AA	10 kohm, 1/16W	R606,607	VRS-CY1JB392J	J AA	3.9 kohms, 1/16W
R50-54	VRS-CY1JB472J	J AA	4.7 kohms, 1/16W	R608-611	VRS-CY1JB222J	J AA	2.2 kohms, 1/16W
R55	VRS-CY1JB473J	J AA	47 kohms, 1/16W	R612,613	VRS-CY1JB391J	J AA	390 ohms, 1/16W
R56	VRD-ST2CD391J	J AA	390 ohms, 1/6W	R614,615	VRS-CY1JB472J	J AA	4.7 kohms, 1/16W
R57	VRS-CY1JB225J	J AA	0.2 Mohms, 1/16W	R616,617	VRS-CY1JB222J	J AA	2.2 kohms, 1/16W
R58	VRS-CY1JB103J	J AA	10 kohm, 1/16W	R618	VRD-ST2CD331J	J AA	330 ohms, 1/6W
R101,102	VRS-CY1JB102J	J AA	1 kohm, 1/16W	R619	VRS-CY1JB331J	J AA	330 ohms, 1/16W
R103,104	VRS-CY1JB222J	J AA	2.2 kohms, 1/16W	R620,621	VRS-CY1JB223J	J AA	22 kohms, 1/16W
R105,106	VRS-CY1JB332J	J AA	3.3 kohms, 1/16W	R641	VRS-CY1JB103J	J AA	10 kohm, 1/16W
R107,108	VRS-CY1JB473J	J AA	47 kohms, 1/16W	R642	VRD-ST2CD103J	J AA	10 kohm, 1/6W
R109,110	VRS-CY1JB472J	J AA	4.7 kohms, 1/16W	R643,644	VRS-CY1JB682J	J AA	6.8 kohms, 1/16W
R111	VRD-ST2CD153J	J AA	15 kohms, 1/6W	R690,691	VRD-ST2CD682J	J AA	6.8 kohms, 1/6W
R112	VRS-CY1JB153J	J AA	15 kohms, 1/16W	R692,693	VRD-ST2CD273J	J AA	27 kohms, 1/6W
R113,114	VRD-ST2CD102J	J AA	1 kohm, 1/6W	R701-703	VRS-CY1JB102J	J AA	1 kohm, 1/16W
R115,116	VRD-ST2CD560J	J AA	56 ohms, 1/6W	R704,705	VRD-ST2CD102J	J AA	1 kohm, 1/6W
R117,118	VRS-CY1JB104J	J AA	100 kohm, 1/16W	R708-712	VRD-ST2CD102J	J AA	1 kohm, 1/6W
R119,120	VRS-CY1JB392J	J AA	3.9 kohms, 1/16W	R713-716	VRS-CY1JB102J	J AA	1 kohm, 1/16W
R121,122	VRS-CY1JB153J	J AA	15 kohms, 1/16W	R717	VRD-ST2CD102J	J AA	1 kohm, 1/6W
R123,124	VRS-CY1JB562J	J AA	5.6 kohms, 1/16W	R718-722	VRS-CY1JB102J	J AA	1 kohm, 1/16W
R126,127	VRS-CY1JB472J	J AA	4.7 kohms, 1/16W	R723	VRD-ST2CD102J	J AA	1 kohm, 1/6W
R128,129	VRS-CY1JB562J	J AA	5.6 kohms, 1/16W	R724	VRS-CY1JB102J	J AA	1 kohm, 1/16W
R130,131	VRS-CY1JB152J	J AA	1.5 kohms, 1/16W	R725	VRD-ST2CD102J	J AA	1 kohm, 1/6W
R132,133	VRS-CY1JB101J	J AA	100 ohm, 1/16W	R726	VRS-CY1JB222J	J AA	2.2 kohms, 1/16W
R134,135	VRS-CY1JB103J	J AA	10 kohm, 1/16W	R727,728	VRS-CY1JB681J	J AA	680 ohms, 1/16W
R136,137	VRS-CY1JB224J	J AA	220 kohms, 1/16W	R729	VRD-ST2CD561J	J AA	560 ohms, 1/6W
R138,139	VRS-CY1JB103J	J AA	10 kohm, 1/16W	R730	VRD-ST2CD102J	J AA	1 kohm, 1/6W
R140	VRS-CY1JB473J	J AA	47 kohms, 1/16W	R731	VRS-CY1JB103J	J AA	10 kohm, 1/16W
R141	VRS-CY1JB472J	J AA	4.7 kohms, 1/16W	R732,733	VRS-CY1JB102J	J AA	1 kohm, 1/16W
R142	VRD-RT2HD820J	J AA	82 ohms, 1/2W	R736	VRS-CY1JB102J	J AA	1 kohm, 1/16W
R143	VRS-CY1JB473J	J AA	47 kohms, 1/16W	R738,739	VRD-ST2CD102J	J AA	1 kohm, 1/6W
R144	VRS-CY1JB223J	J AA	22 kohms, 1/16W	R740	VRD-ST2CD101J	J AA	100 ohm, 1/6W
R145	VRD-ST2CD4R7J	J AA	4.7 ohms, 1/6W	R741	VRD-ST2CD102J	J AA	1 kohm, 1/6W
R146,147	VRS-CY1JB103J	J AA	10 kohm, 1/16W	R745	VRD-ST2CD103J	J AA	10 kohm, 1/6W
R148	VRS-CY1JB472J	J AA	4.7 kohms, 1/16W	R746	VRD-ST2CD102J	J AA	1 kohm, 1/6W
R149	VRD-ST2EE151J	J AA	150 ohms, 1/4W	R750	VRD-ST2CD473J	J AA	47 kohms, 1/6W
R150	VRS-CY1JB683J	J AA	68 kohms, 1/16W	R751	VRD-ST2CD331J	J AA	330 ohms, 1/6W
R158	VRD-ST2EE221J	J AA	220 ohms, 1/4W	R759	VRD-ST2CD562J	J AA	5.6 kohms, 1/16W
R302	VRS-CY1JB100J	J AA	10 ohm, 1/16W	R761,762	VRS-CY1JB103J	J AA	10 kohm, 1/16W
R309	VRD-ST2CD103J	J AA	10 kohm, 1/6W	R763	VRS-CY1JB102J	J AA	1 kohm, 1/16W
R311	VRS-CY1JB104J	J AA	100 kohm, 1/16W	R766-768	VRS-CY1JB103J	J AA	10 kohm, 1/16W
R313	VRS-CY1JB333J	J AA	33 kohms, 1/16W	R769	VRD-ST2CD102J	J AA	1 kohm, 1/6W
R314	VRD-ST2CD220J	J AA	22 ohms, 1/6W	R770	VRS-CY1JB562J	J AA	5.6 kohms, 1/16W
R316	VRS-CY1JB472J	J AA	4.7 kohms, 1/16W	R771	VRD-ST2CD472J	J AA	4.7 kohms, 1/6W
R322	VRS-CY1JB681J	J AA	680 ohms, 1/16W	R773	VRS-CY1JB103J	J AA	10 kohm, 1/16W
R323	VRS-CY1JB683J	J AA	68 kohms, 1/16W	R775,776	VRS-CY1JB472J	J AA	4.7 kohms, 1/16W
R325	VRS-CY1JB473J	J AA	47 kohms, 1/16W	R777-779	VRS-CY1JB103J	J AA	10 kohm, 1/16W
R336	VRS-CY1JB103J	J AA	10 kohm, 1/16W	R780	VRD-ST2CD103J	J AA	10 kohm, 1/6W
R350	VRS-CY1JB272J	J AA	2.7 kohms, 1/16W	R781	VRS-CY1JB473J	J AA	47 kohms, 1/16W
R351	VRS-CY1JB562J	J AA	5.6 kohms, 1/16W	R782	VRD-ST2CD104J	J AA	100 kohm, 1/6W
R352	VRS-CY1JB102J	J AA	1 kohm, 1/16W	R783	VRS-CY1JB101J	J AA	100 ohm, 1/16W
R353	VRS-CY1JB271J	J AA	270 ohms, 1/16W	R784	VRS-CY1JB102J	J AA	1 kohm, 1/16W
				R785	VRS-CY1JB272J	J AA	2.7 kohms, 1/16W
				R786	VRS-CY1JB472J	J AA	4.7 kohms, 1/16W

NO.	PART CODE	★ PRICE RANK	DESCRIPTION
R787	VRD-ST2CD472J	J AA	4.7 kohms,1/6W
R788,789	VRD-ST2CD103J	J AA	10 kohm,1/6W
R790	VRS-CY1JB822J	J AA	8.2 kohms,1/16W
R791	VRS-CY1JB103J	J AA	10 kohm,1/16W
R794,795	VRD-ST2EE1R5J	J AA	1.5 ohms,1/4W
R801	VRD-ST2CD104J	J AA	100 kohm,1/6W
R802	VRD-ST2CD473J	J AA	47 kohms,1/6W
R803	VRD-ST2CD123J	J AA	12 kohms,1/6W
R804,805	VRD-ST2EE470J	J AA	47 ohms,1/4W
R806	VRD-ST2CD473J	J AA	47 kohms,1/6W
R808	VRD-RT2HD222J	J AA	2.2 kohms,1/2W
R841	VRD-ST2CD224J	J AA	220 kohms,1/6W
R842	VRD-ST2CD102J	J AA	1 kohm,1/6W
R843	VRD-ST2CD473J	J AA	47 kohms,1/6W
R844	VRD-ST2EE820J	J AA	82 ohms,1/4W
R853	VRD-ST2CD223J	J AA	22 kohms,1/6W
R854	VRD-ST2CD332J	J AA	3.3 kohms,1/6W
R857	VRD-ST2CD223J	J AA	22 kohms,1/6W
R858	VRD-ST2CD221J	J AA	220 ohms,1/6W
R859	VRD-ST2CD103J	J AA	10 kohm,1/6W
R863	VRD-RT2HD3R3J	J AA	3.3 ohms,1/2W
R864	VRD-ST2CD223J	J AA	22 kohms,1/6W
R885	VRS-CY1JB681J	J AA	680 ohms,1/16W
R886,887	VRS-CY1JB223J	J AA	22 kohms,1/16W
R888,889	VRD-ST2CD473J	J AA	47 kohms,1/6W
△ R890	RR-HZ0001AWZZ	J AE	4.7 Mohms,1/2W
R891	VRD-ST2EE101J	J AA	100 ohm,1/4W
R901,902	VRS-CY1JB563J	J AA	56 kohms,1/16W
R903,904	VRS-CY1JB102J	J AA	1 kohm,1/16W
R905,906	VRS-CY1JB561J	J AA	560 ohms,1/16W
R907	VRS-CY1JB563J	J AA	56 kohms,1/16W
R908	VRS-CY1JB102J	J AA	1 kohm,1/16W
R909	VRS-CY1JB333J	J AA	33 kohms,1/16W
R910	VRD-ST2CD102J	J AA	1 kohm,1/6W
R911	VRS-CY1JB563J	J AA	56 kohms,1/16W
△ R912	VRG-ST2EC101J	J AB	100 ohm,1/4W,Fusable
R913	VRN-CM05NR22J	J AD	0.22 ohms,5W
R916	VRN-CM05NR22J	J AD	0.22 ohms,5W
R917	VRN-CM05NR1R1J	J AD	0.1 ohm,5W
R918	VRD-ST2CD222J	J AA	2.2 kohms,1/6W
R919,920	VRS-CY1JB152J	J AA	1.5 kohms,1/16W
R921	VRD-ST2CD222J	J AA	2.2 kohms,1/6W
R922	VRN-CM05NR1R1J	J AD	0.1 ohm,5W
R925,926	VRD-RT2HD152J	J AA	1.5 kohms,1/2W
R927,928	VRD-ST2EE393J	J AA	39 kohms,1/4W
R929,930	VRD-ST2EE473J	J AA	47 kohms,1/4W
R934,935	VRD-ST2CD563J	J AA	56 kohms,1/6W
R937	VRS-CY1JB563J	J AA	56 kohms,1/16W
R938-941	VRD-RT2HD100J	J AA	10 ohm,1/2W
R942,943	VRS-VV3DA681J	J AC	680 ohms,2W
R944,945	VRD-ST2CD152J	J AA	1.5 kohms,1/6W
R946	VRS-CY1JB473J	J AA	47 kohms,1/16W
R947	VRS-CY1JB153J	J AA	15 kohms,1/16W
R949	VRD-RT2HD102J	J AA	1 kohm,1/2W
R950	VRD-ST2CD683J	J AA	68 kohms,1/6W
R951	VRD-RT2HD102J	J AA	1 kohm,1/2W
R956	VRS-CY1JB102J	J AA	1 kohm,1/16W
R957	VRS-CY1JB472J	J AA	4.7 kohms,1/16W
△ R958	VRG-ST2EC101J	J AB	100 ohm,1/4W,Fusable
R959	VRS-CY1JB221J	J AA	220 ohms,1/16W
R983	VRS-CY1JB333J	J AA	33 kohms,1/16W
R984	VRS-CY1JB152J	J AA	1.5 kohms,1/16W
R985,986	VRS-CY1JB562J	J AA	5.6 kohms,1/16W
R987,988	VRS-CY1JB222J	J AA	2.2 kohms,1/16W
RD01	VRD-ST2CD681J	J AA	680 ohms,1/6W
RD02	VRS-CY1JB821J	J AA	820 ohms,1/16W
RD03	VRS-CY1JB102J	J AA	1 kohm,1/16W
RD04	VRD-ST2CD152J	J AA	1.5 kohms,1/6W
RD05	VRS-CY1JB222J	J AA	2.2 kohms,1/16W
RD06	VRS-CY1JB272J	J AA	2.7 kohms,1/16W
RD11	VRS-CY1JB681J	J AA	680 ohms,1/16W
RD12	VRS-CY1JB821J	J AA	820 ohms,1/16W
RD13	VRD-ST2CD102J	J AA	1 kohm,1/6W
RD14	VRS-CY1JB152J	J AA	1.5 kohms,1/16W
RD23	VRD-ST2CD681J	J AA	680 ohms,1/6W
RD24	VRD-ST2CD821J	J AA	820 ohms,1/6W
RD25	VRD-ST2CD102J	J AA	1 kohm,1/6W
RD26	VRS-CY1JB152J	J AA	1.5 kohms,1/16W
RD27	VRS-CY1JB222J	J AA	2.2 kohms,1/16W
RD28	VRS-CY1JB272J	J AA	2.7 kohms,1/16W
RD29	VRS-CY1JB392J	J AA	3.9 kohms,1/16W
RD30	VRS-CY1JB562J	J AA	5.6 kohms,1/16W

NO.	PARTS CODE	★ PRICE RANK	DESCRIPTION
RD31	VRS-CY1JB103J	J AA	10 kohm,1/16W
RD32	VRS-CY1JB153J	J AA	15 kohms,1/16W

OTHER CIRCUITRY PARTS

BI601/CNS601	QCNCWN2715AWPZ	J AG	Connector Ass'y,9/8Pin
BI603/CNS603	QCNCWN2714AWPZ	J AK	Connector Ass'y,6/5Pin
BI801/CNS801	QCNCWN2713AWPZ	J AH	Connector Ass'y,11/10Pin
CNP1	QCNCWYP16AWZZ	J AD	Socket,16Pin
CNP2	92LCONE8P53254	J AC	Plug,8Pin
CNP3	92LCONE6P53253	J AC	Plug,6Pin
CNP3A	92LCONE6P53254	J AC	Plug,6Pin
CNP4	QCNCWZX11AWZZ	J AC	Socket,11Pin
CNP4A	QCNCWZO11AWZZ	J AC	Socket,11Pin
CNP5	QCNCWZY14AWZZ	J AD	Socket,14Pin
CNP101	QCNCM705CAFZZ	J AA	Plug,3Pin
CNP102	QCNCM705GAFZZ	J AB	Plug,7Pin
CNP301	92LCONE2P5268	J AB	Plug,2Pin
CNP602	92LCONE5P53253	J AB	Plug,5Pin
CNP701A	QCNCWZY16AWZZ	J AD	Socket,16Pin
CNP701B	QCNCWZX16AWZZ	J AD	Socket,16Pin
CNP702A	QCNCWZY07AWZZ	J AC	Socket,7Pin
CNP704	QCNCWZY14AWZZ	J AD	Socket,14Pin
CNP801	92LCONEAP5267X	J AC	Plug,10Pin
CNP802	QCNCW012FAWZZ	J AC	Plug,6Pin
CNP901	QCNCW012EAWZZ	J AC	Socket,5Pin
CNP971	92LCONE2P53253	J AB	Plug,2Pin
CNS3A/B	QCNCWN2699AWPZ	J AF	Connector Ass'y,6/6Pin
CNS971	QCNCWNA080AWPZ	J AC	Connector Ass'y,2Pin
△ F801,802	QFS-D502BSJNI	J AE	Fuse,5A/125V
△ F803,804	QFS-D202BSJNI	J AB	Fuse,2A/125V
△ F805	QFS-D502BSJNI	J AE	Fuse,5A/125V
FFC1	QCNCWN2700AWPZ	J AE	Flat Cable,16Pin
FFC4	QCNCWN2701AWPZ	J AD	Flat Cable,11Pin
FFC701	QCNCWN2716AWPZ	J AF	Flat Cable,16Pin
FFC702	QCNCWN2495AWZZ	J AD	Flat Cable,7Pin
FFC704	QCNCWN2717AWPZ	J AF	Flat Cable,14Pin
FL701	VVKNA11SS55-1	J AV	FL Display
FW705	QCNCWN2712AWPZ	J AD	Flat Wire,6Pin
FW901	QCNCWN2711AWPZ	J AD	Flat Wire,5Pin
JK690	QSOCJ0313AWZZ	J AF	Jack,Game Input
JK691	QSOCJ0120AWZZ	J AD	Jack,Video Out
JK692	QJAKM0004AWZZ	J AK	Jack,Headphones
JOG701	QSW-ZA001AWZZ	J AE	Switch,Jog Type [Volume]
LG1-4	QLUGP0001AWZZ	J AC	Lug Terminal
M1	92LMTR5529AASY	J AD	Motor with Gear [Tray]
M2	92LMTR5529AASY	J AD	Motor with Gear [Main Cam]
M901	RMOTV00559AWZZ	J AL	Motor Air Cooling,Fan
NM1	92LMTR5515CASY	J J	Motor with Chassis [Spindle]
NM2	92LMTR1854BASY	J AP	Motor with Gear [Sled]
NSW1	QSW-F9001AW01	J AD	Switch,Push Type [Pickup In]
△ RL841	RRLYD0018AWZZ	J AH	Relay
RL914	RRLYD0016AWZZ	J AH	Relay
RX1	VHPGP1S094HCZ	J AF	Photo Interrupter,GP1S094HCZ
RX701	VHLPIC3704/-1	J AG	Remote Sensor,PIC3704
SO302	QTANC0206AWZZ	J AD	Terminal,FM Antenna
SO902	QTANA0424AWZZ	J AE	Terminal,Speaker
SW1	QSW-P9003AWZZ	J AD	Switch,Push Type [Clamp]
SW2	QSW-P9003AWZZ	J AD	Switch,Push Type [Tray SW1]
SW3	QSW-P9003AWZZ	J AD	Switch,Push Type [Tray SW2]
SW4	QSW-P9006AWZZ	J AF	Switch,Push Type [Disc]
SW701	92LSWICH1401AT	J AC	Switch,Key Type [Power On/Stand-by]
SW702	92LSWICH1401AT	J AC	Switch,Key Type [Clock/Timer]
SW703	92LSWICH1401AT	J AC	Switch,Key Type [Tuning Up]
SW704	92LSWICH1401AT	J AC	Switch,Key Type [Tuning Down]
SW705	92LSWICH1401AT	J AC	Switch,Key Type [Fast Rewind/ Preset Down]
SW706	92LSWICH1401AT	J AC	Switch,Key Type [Equalizer]
SW707	92LSWICH1401AT	J AC	Switch,Key Type [Fast Forward/Preset Up]
SW712	92LSWICH1401AT	J AC	Switch,Key Type [Tuner (Band)]
SW713	92LSWICH1401AT	J AC	Switch,Key Type [CD]
SW714	92LSWICH1401AT	J AC	Switch,Key Type [Tape]
SW715	92LSWICH1401AT	J AC	Switch,Key Type [Game/Video]
SW716	92LSWICH1401AT	J AC	Switch,Key Type [X-Bass/Demo]
SW725	92LSWICH1401AT	J AC	Switch,Key Type [Play/Repeat]
SW726	92LSWICH1401AT	J AC	Switch,Key Type [Stop]
SW727	92LSWICH1401AT	J AC	Switch,Key Type [Rec/Pause]
SW728	92LSWICH1401AT	J AC	Switch,Key Type [Memory/Set]
SW729	92LSWICH1401AT	J AC	Switch,Key Type [Open/Close]
SW730	92LSWICH1401AT	J AC	Switch,Key Type [Direct Play]

CD-ES900/CD-ES99

NO.	PART CODE	★	PRICE RANK	DESCRIPTION
SW731	92LSWICH1401AT	J	AC	Switch,Key Type [Disc2]
SW732	92LSWICH1401AT	J	AC	Switch,Key Type [Disc4]
SW733	92LSWICH1401AT	J	AC	Switch,Key Type [Disc5]
SW734	92LSWICH1401AT	J	AC	Switch,Key Type [Disc3]
SW735	92LSWICH1401AT	J	AC	Switch,Key Type [Disc1]
WTM705	QCNCW019FAWZZ	J	AB	Socket,6Pin
WTM901	QCNCW019EAWZZ	J	AB	Socket,5Pin

CD MECHANISM PARTS

301	NGERH0011AWZZ	J	AC	Gear,Middle
302	NGERH0012AWZZ	J	AC	Gear,Drive
304	NSFTM0020AWFW	J	AD	Shaft,Guide
305	92LMCUSN1524A	J	AD	Cushion
△ 306	92LHPC1LFASY	J	BB	Pickup Unit Ass'y
306- 2	NGERR0043AFZZ	J	AC	Gear,Rack
306- 3	MSPRC0961AFZZ	J	AA	Spring,Rack
307	PCUSG0001AWSA	J	AD	Cushion
308	PCUSG0004AWSA	J	AD	Cushion
701	XBSSD26P06000	J	AA	Screw,ø2.6×6mm
703	XBSSD20P03000	J	AA	Screw,ø2×3mm
704	LX-WZ1070AFZZ	J	AA	Washer,ø1.5×ø3.8×0.25mm
NM1	92LMTR5515CASY	J		Motor with Chassis [Spindle]
NM2	92LMTR1854BASY	J	AP	Motor with Gear [Sled]
NSW1	QSW-F9001AW01	J	AD	Switch,Push Type [Pickup In]

CHANGER MECHANISM PARTS

101	GCOVA1513AWZZ	J	AF	Disc Tray
102	GCOVA1514AWZZ	J	AF	Guide Tray
103	LANGG0008AWZZ	J	AD	Outer Tray Guide
104	LANGG0009AWZZ	J	AC	Inner Tray Guide
105	LCHSM0194AWZZ	J	AP	Main Base
106	LHLDZ9017AWZZ	J	AF	CD Mechanism Holder
107	LPLTP0014AWZZ	J	AK	Top Plate
108	LPLTP0015AWZZ	J	AG	Gear Plate
109	MHOLD5529ASY	J	AP	Up/Down Holder Ass'y
109- 1	LHLDM9001AWZZ	J	AD	Stabilizer
109- 2	LHLDZ9019AWM1	J	AK	Up/Down Holder Ass'y
109- 3	LPLTM0017AWZZ	J	AB	Stabilizer Plate
109- 4	LPLTMA001AWFW	J	AC	Plate
109- 5	PMAGF0003AWZZ	J	AF	Magnet
110	MLEVPO129AWZZ	J	AC	Tray Lock Lever
111	MLEVPO130AWZZ	J	AG	Gear Up/Down Board
112	MLEVPO131AWZZ	J	AD	Mechanism Up/Down Board (L)
113	MLEVPO132AWZZ	J	AD	Mechanism Up/Down Board (R)
114	MLEVPO133AWZZ	J	AC	Mechanism Clamp Board
115	MLEVPO134AWZZ	J	AD	L/R Joint Lver
116	MLEVPO135AWZZ	J	AC	Tray Set Lever
117	MLEVPO136AWZZ	J	AC	Mechanism Clamp Switch Lever
118	MLEVPO137AWZZ	J	AC	Mechanism Clamp Switch Arm
119	MLEVPO138AWZZ	J	AB	Inner GR Up/Down Lever
120	MLEVPO139AWZZ	J	AC	Outer GR Up/Down Lever
121	MSPRC0044AWFJ	J	AB	Shift Spring
122	MSPRD0191AWFJ	J	AC	Disc Stop Spring
123	MSPRD0192AWFJ	J	AB	Balance Spring
124	NGERH0176AWZZ	J	AF	Tray Big Gear
125	NGERH0177AWZZ	J	AC	Tray Front Gear A
126	NGERH0178AWZZ	J	AC	Tray Front Gear B
127	NGERH0179AWZZ	J	AC	Tray Rear Gear A
128	NGERH0180AWZZ	J	AB	Tray Rear Gear B
129	NGERH0181AWZZ	J	AC	Mechanism Clamp Gear A
130	NGERH0182AWZZ	J	AC	Mechanism Clamp Joint Gear
131	NGERH0183AWZZ	J	AC	Mechanism Clamp Board Gear
132	NGERH0184AWZZ	J	AC	Tray Rear Joint Gear A
133	NGERH0185AWZZ	J	AC	Tray Rear Joint Gear B
134	NGERH0186AWZZ	J	AC	Tray Rear Joint Gear C
135	NGERH0187AWZZ	J	AB	Tray Rear Drive Gear
136	NGERH0188AWZZ	J	AC	Tray Drive Gear
137	NGERH0189AWZZ	J	AB	Tray Front Drive Gear
138	NGERH0190AWZZ	J	AC	Tray Front Joint Gear
139	NGERH0191AWZZ	J	AE	Mode Big Gear
140	NGERH0192AWZZ	J	AC	G-Up/Down Gear A
141	NGERH0193AWZZ	J	AC	G-Up/Down Gear B
142	NGERH0194AWZZ	J	AB	Mechanism Up/Down Gear A
143	NGERH0195AWZZ	J	AC	Mechanism Up/Down Gear B
144	NGERH0196AWZZ	J	AC	Mechanism Clamp Switch Gear
145	NGERH0198AWZZ	J	AB	Reduction Gear A
146	NGERH0199AWZZ	J	AB	Reduction Gear B
147	NGERH0200AWZZ	J	AB	Reduction Gear C
148	NGERH0201AWZZ	J	AB	Reduction Gear D

NO.	PARTS CODE	★	PRICE RANK	DESCRIPTION
149	NGERH0202AWZZ	J	AB	Up/Down Reduction Gear E
150	NGERH0203AWZZ	J	AB	Up/Down Reduction Gear F
151	NGERH0204AWZZ	J	AB	Tray Reduction Gear E
152	NSFTT0084AWFD	J	AD	Shaft,Main Base
801	LX-BZA006AWFD	J	AB	Screw,Special
803	XEBSD20P10000	J	AA	Screw,ø2×10mm
804	XEBSD30P10000	J	AA	Screw,ø3×10mm
M1	92LMTR5529AASY	J	AD	Motor with Gear [Tray]
M2	92LMTR5529AASY	J	AD	Motor with Gear [Main Cam]
SW1	QSW-P9003AWZZ	J	AD	Switch,Push Type [CLAMP]
SW2	QSW-P9003AWZZ	J	AD	Switch,Push Type [TRAY SW1]
SW3	QSW-P9003AWZZ	J	AD	Switch,Push Type [TRAY SW2]
SW4	QSW-P9006AWZZ	J	AF	Switch,Push Type [DISC]

CABINET PARTS

201	CCABA5529AW01	J		Front Panel Ass'y [CD-ES99]
201	CCABA5530AW01	J		Front Panel Ass'y [CD-ES900]
201- 1	—	—		Front Panel (Not Replacement Item)
201- 2	GCOVAA026AWSA	J	AG	Cover,Cassette [Tape 1] [CD-ES99]
201- 2	GCOVA1521AWSA	J	AK	Cover,Cassette [Tape 1] [CD-ES900]
201- 3	GCOVAA027AWSA	J	AG	Cover,Cassette [Tape 2] [CD-ES99]
201- 3	GCOVA1522AWSA	J	AK	Cover,Cassette [Tape 2] [CD-ES900]
201- 4	GDORF0127AWSA	J	AE	Holder,Cassette [Tape 1]
201- 5	GDORF0128AWSA	J	AE	Holder,Cassette [Tape 2]
201- 6	HDECQ1108AWSA	J	AE	Panel,Cassette [Tape 1]
201- 7	HDECQ1109AWSA	J	AE	Panel,Cassette [Tape 2]
201- 8	JKNBZA022AWSA	J	AF	Button,Disc Number [CD-ES99]
201- 8	JKNBZ0982AWSA	J	AE	Button,Disc Number [CD-ES900]
201- 9	MLIF-A001AWZZ	J	AD	Damper
201-10	JKNBZA023AWSA	J	AM	Button,Operation A [CD-ES99]
201-10	JKNBZA023AWSB	J		Button,Operation A [CD-ES900]
201-11	JKNBZA024AWSA	J	AM	Button,Operation B [CD-ES99]
201-11	JKNBZA024AWSB	J		Button,Operation B [CD-ES900]
201-12	JKNBZ0985AWSA	J	AE	Button,Function
201-13	JKNBZA026AWSA	J	AF	Button,Memory [CD-ES99]
201-13	JKNBZ0986AWSA	J	AE	Button,Memory [CD-ES900]
201-14	JKNBZA027AWSA	J	AF	Button,Tuning [CD-ES99]
201-14	JKNBZ0987AWSA	J	AE	Button,Tuning [CD-ES900]
201-15	JKNBZA030AWSA	J	AG	Button,Power [CD-ES99]
201-15	JKNBZ0991AWSA	J	AF	Button,Power [CD-ES900]
201-16	GCOVA1533AWSA	J	AC	Cover,Timer
201-17	HBDGB1007AWSA	J	AD	Badge,SHARP
201-18	MSPRDA002AWFJ	J	AB	Spring,Cassette [Tape 1]
201-19	MSPRDA003AWFJ	J	AB	Spring,Cassette [Tape 2]
201-20	HDECQA039AWSA	J	AH	Volume Knob Ring,A [CD-ES900]
201-20	HDECQ1105AWSA	J	AG	Volume Knob Ring,A [CD-ES99]
201-21	HDECQ1106AWSA	J	AF	Volume Knob Ring,B
201-22	HDECQA015AWSA	J	AH	Decoration Plate,Amp. [CD-ES99]
201-22	HDECQ1107AWSA	J	AH	Decoration Plate,Amp. [CD-ES900]
201-23	MLOKC0014AWZZ	J	AC	Lock,Cassette [Tape 1]
201-24	MLOKC0015AWZZ	J	AC	Lock,Cassette [Tape 2]
201-25	MSPRD0196AWFJ	J	AB	Spring,Cassette Lock [Tape 1]
201-26	MSPRD0197AWFJ	J	AC	Spring,Cassette Lock [Tape 2]
202	GCAB-A006AWSA	J	AY	Cabinet,Top/Side [CD-ES99]
202	GCAB-3101AWSA	J	AY	Cabinet,Top/Side [CD-ES900]
203	PCUSG0022AWZZ	J	AB	Cushion,Leg
204	GITARA022AWSA	J	AL	Rear Panel,B [CD-ES900]
204	GITAR1274AWSA	J		Rear Panel,B [CD-ES99]
205	GCOVA1520AWSA	J	AG	Cover,CD Tray
206	LCHSZ0025AWZZ	J	AM	Chassis,Changer
207	PSLDMA009AWFW	J		Shield,Dust Cover
208	92LNBAND1318A	J	AA	Nylon Band,80mm
209	KMECBA001AWZZ	J	BC	Tape Mechanism Ass'y
209- 1	92PF513-905	J		Head Plate Block [Tape 2]
209- 2	92PF525-357	J		Motor with Pulley [Tape]
209- 3(PWB-D)	—	—		Tape Mechanism PWB Ass'y
209- 4	92PF522-063	J		Clut Ass'y Block [Tape 2]
209- 5	92PFF20D-12	J		Belt,Main [Tape 2]
209- 6	92PF514-131	J		Pinch Roller
209- 7	92PFF19S-31	J		Belt,FF/REW [Tape 1]
209- 8	92PFF19S-13	J		Belt,Main [Tape 1]
209- 9	92PF522-061	J		Clut Ass'y Block [Tape 1]

NO.	PART CODE	★ PRICE RANK	DESCRIPTION
209-10	92PFF19S-52	J	Belt,FF/REW [Tape 2]
209-11	92PFF513-906	J	Head Plate Block [Tape 1]
210	HDECQA033AWSA	J AE	Panel,Edge Light
212	QCNWN1860AWZZ	J AC	Lug Wire
213	JKNBK0103AWSA	J AD	Knob,Volume
214	HDECQ1104AWSA	J AL	Cover,Volume Knob
215	PSHEPA007AWZZ	J AE	Sheet,Edge Light
216	92LCSRP1431C	J AA	Spring,Ring
217	LCHSM0201AWFW	J AR	Chassis,Main
218	GITAR1273AWSA	J AP	Rear Panel,A
219	LBND-1011AWZZ	J AA	Nylon Band
△ 220	QACCD0022AWZZ	J AM	AC Power Supply Cord
221	LBSHC0005AWZZ	J AD	Bushing,AC Power Supply Cord
222	NFANP0001AWZZ	J AD	Rotary Fan
223	LANGK0437AWFW	J AE	Bracket,Fan Support A
△ 224	QFSDH0001AWZZ	J AB	Holder,Fuse
225	PRDAR0320AWFW	J AV	Heat Sink
226	LHLDZ9023AWZZ	J AD	Holder,Edge Light A
227	LANGT0042AWFW	J AC	Bracket,PWB Support
228	PSHEPA010AWZZ	J AE	Shield Sheet,Main PWB
229	LHLDZA0004AWZZ	J AC	Holder,Rib Support
230	LANGK0435AWFW	J AF	Bracket,Heat Sink Support
601	XJBSD30P10000	J AA	Screw,ø3×10mm
602	XEBSD30P10000	J AA	Screw,ø3×10mm
603	LX-EZ0005AWFD	J AA	Screw,ø2.6×10mm
604	XEBSD26P10000	J AA	Screw,ø2.6×10mm
605	XESSD30P10000	J AA	Screw,ø3×10mm
606	XJSSD30P08000	J AA	Screw,ø3×10mm
607	LX-EZ0010AWFD	J AA	Screw,Special
608	XHBSD40P08000	J AA	Screw,ø4×8mm
609	XBBSD20P04000	J AA	Screw,ø2×4mm
610	LX-JZ0010AFFD	J AA	Screw,ø3×10mm
611	LX-LZA002AWZZ	J AD	Push Rivet
612	LX-LZ0002AW00	J AC	Snap Rivet
613	LX-JZ0037AWFD	J AB	Screw,ø3×18mm
614	LX-JZ0044AWFF	J AB	Screw,ø3×10mm
615	XWHSD32-10080	J AA	Washer,ø3.2×ø8×1mm
616	XHBSD30P06000	J AA	Screw,ø3×6mm
617	LX-JZ0036AWFD	J AB	Screw,Special

ACCESSORIES

QANTL0005AWZZ	J AG	AM Loop Antenna
TINSEA002AWZZ	J AE	Operation Manual
TINSZA003AWZZ	J AD	Quick Guide
TLABZA028AWZZ	J AF	Label,Feature,Speaker
TLABZA092AWZZ	J	Energy Star Label (Set)
92LFANT1746A	J AD	FM Antenna
RRMCG0391AWSA	J AR	Remote Control
GFTAT1017AWSA	J AG	Lid,Remote Control

P.W.B. ASSEMBLY (Not Replacement Item)

PWB-A1~3	92LPWB5529MANS	J —	Main/Display/Spacer (Combined Ass'y)
△ PWB-B1,2	92LPWB5529PWRS	J —	Power/Game Input (Combined Ass'y)
PWB-C	92LPWB5529CDUS	J —	CD Servo
PWB-D(209-3)	—	—	Tape Mechanism
PWB-E	QPWBF1055AWZZ	J AE	5-Changer Motor (PWB Only)
PWB-F	QPWBF0027AWZZ	J AD	CD Motor (PWB Only)

OTHER SERVICE PART

UDSKA0004AFZZ	J AZ	CD Pickup Lens Cleaner
---------------	------	------------------------

CP-ES900/CP-ES99

SPEAKER BOX PARTS

NO.	PARTS CODE	★ PRICE RANK	DESCRIPTION
901	GBOXLA009AWSA	J BF	Speaker Box Ass'y,Left [CP-ES900]
901	GBOXLA010AWSA	J BE	Speaker Box Ass'y,Left [CP-ES99]
902	GBOXRA009AWSA	J BF	Speaker Box Ass'y,Right [CP-ES900]
902	GBOXRA010AWSA	J BE	Speaker Box Ass'y,Right [CP-ES99]
903	CPNLSA005AW01	J BD	Front Panel Ass'y,Left [CP-ES900]
903	CPNLSA005AW02	J BD	Front Panel Ass'y,Left [CP-ES99]
904	CPNLSA006AW01	J BD	Front Panel Ass'y,Right [CP-ES900]
904	CPNLSA006AW02	J BD	Front Panel Ass'y,Right [CP-ES99]
905	HPNLSA007AWSA	J AX	Side Panel,Left [CP-ES900]
905	HPNLSA007AWSB	J AX	Side Panel,Left [CP-ES99]
906	HPNLSA008AWSA	J AX	Side Panel,Right [CP-ES900]
906	HPNLSA008AWSB	J AX	Side Panel,Right [CP-ES99]
907	TSPC-A013AWZZ	J AB	Label,Specifications [CP-ES900]
907	TSPC-A018AWZZ	J AC	Label,Specifications [CP-ES99]
908	PFLT-0046AWZZ	J AC	Felt
909	QCNWNA001AWZZ	J	Speaker Cord Ass'y (with Capacitor C1,2)
910	XJBSD40P16000	J AB	Screw,ø4×16mm
911	XJBSD30P12000	J AA	Screw,ø3×12mm
912	XMPSF40P35000	J AC	Screw,ø4×35mm
913	XMBSF40P16000	J AC	Screw,ø4×16mm
914	PCUSG0147AWZZ	J AC	Leg Cushion
915	QCNWHA001AWZZ	J	Speaker Cord
SP1,2	RSP-ZA006AWZZ	J BC	Woofer [CP-ES900]
SP1,2	RSP-ZA027AWZZ	J	Woofer [CP-ES99]
SP3,4	RSP-ZA007AWZZ	J AS	Tweeter
SP5,6	RSP-ZA008AWZZ	J AS	Passive Radiator
SP7~10	LHLDZA006AWM1	J	Super Tweeter Ass'y

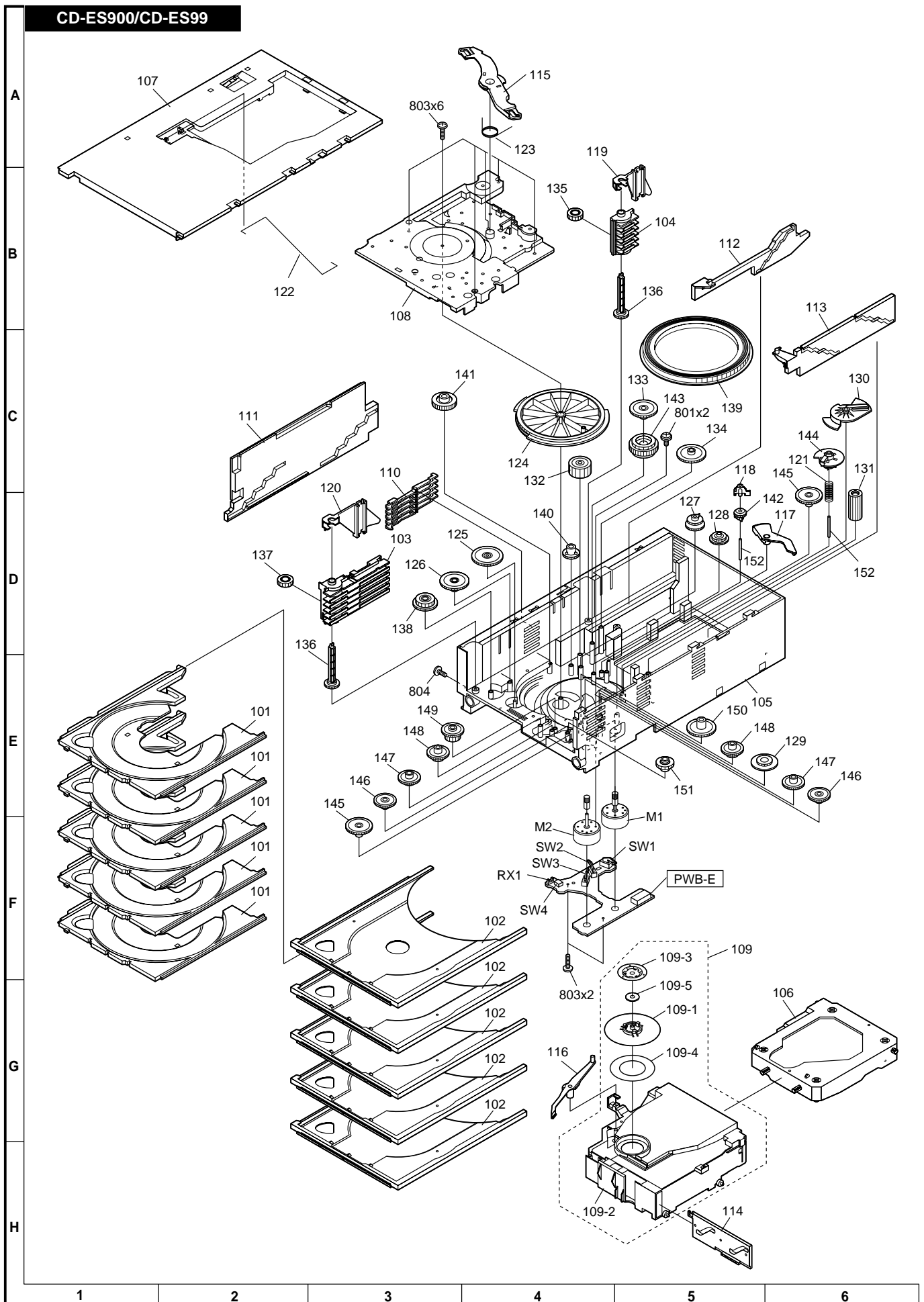

Figure 7 CD CHANGER MECHANISM EXPLODED VIEW

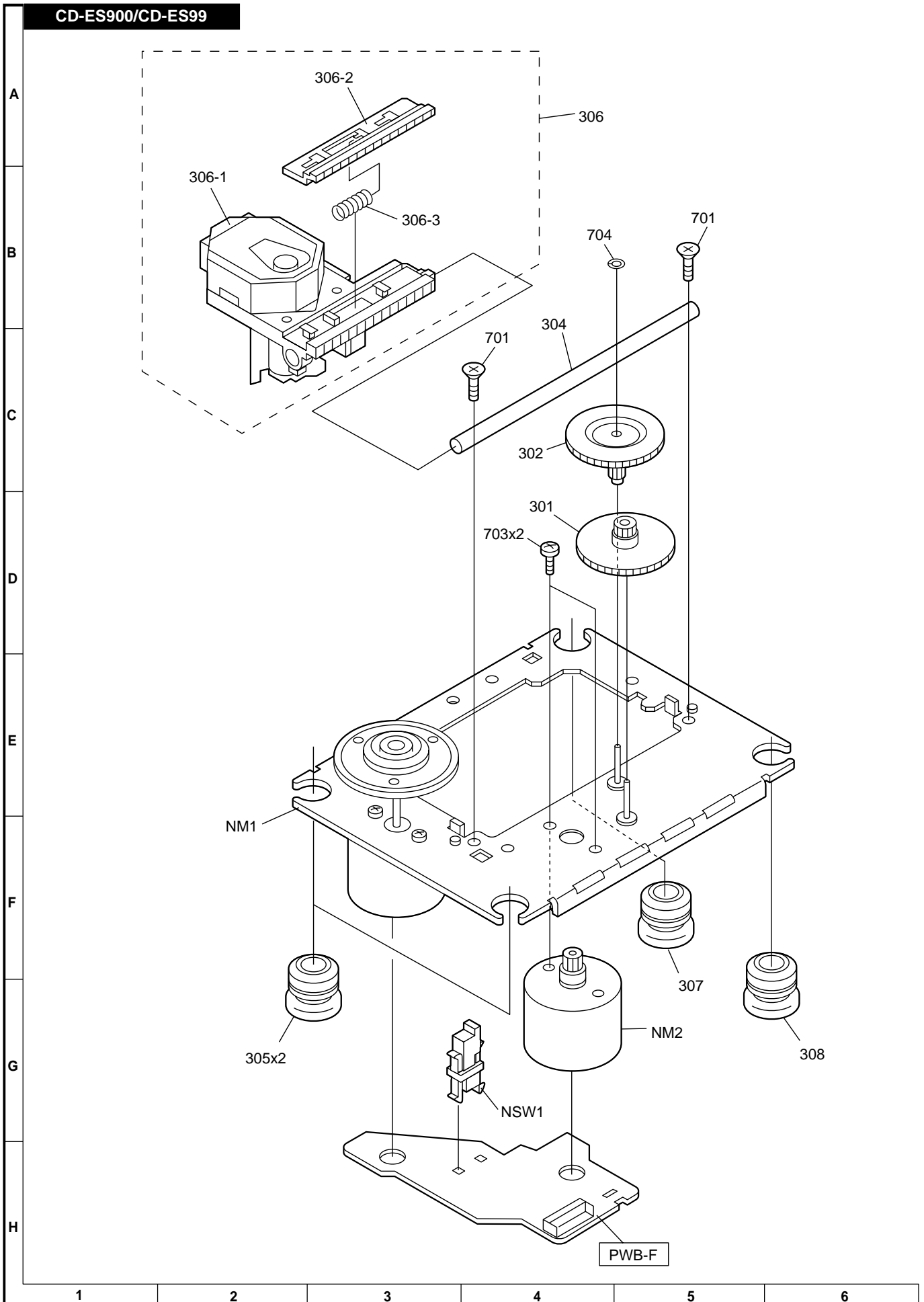

Figure 8 CD MECHANISM EXPLODED VIEW

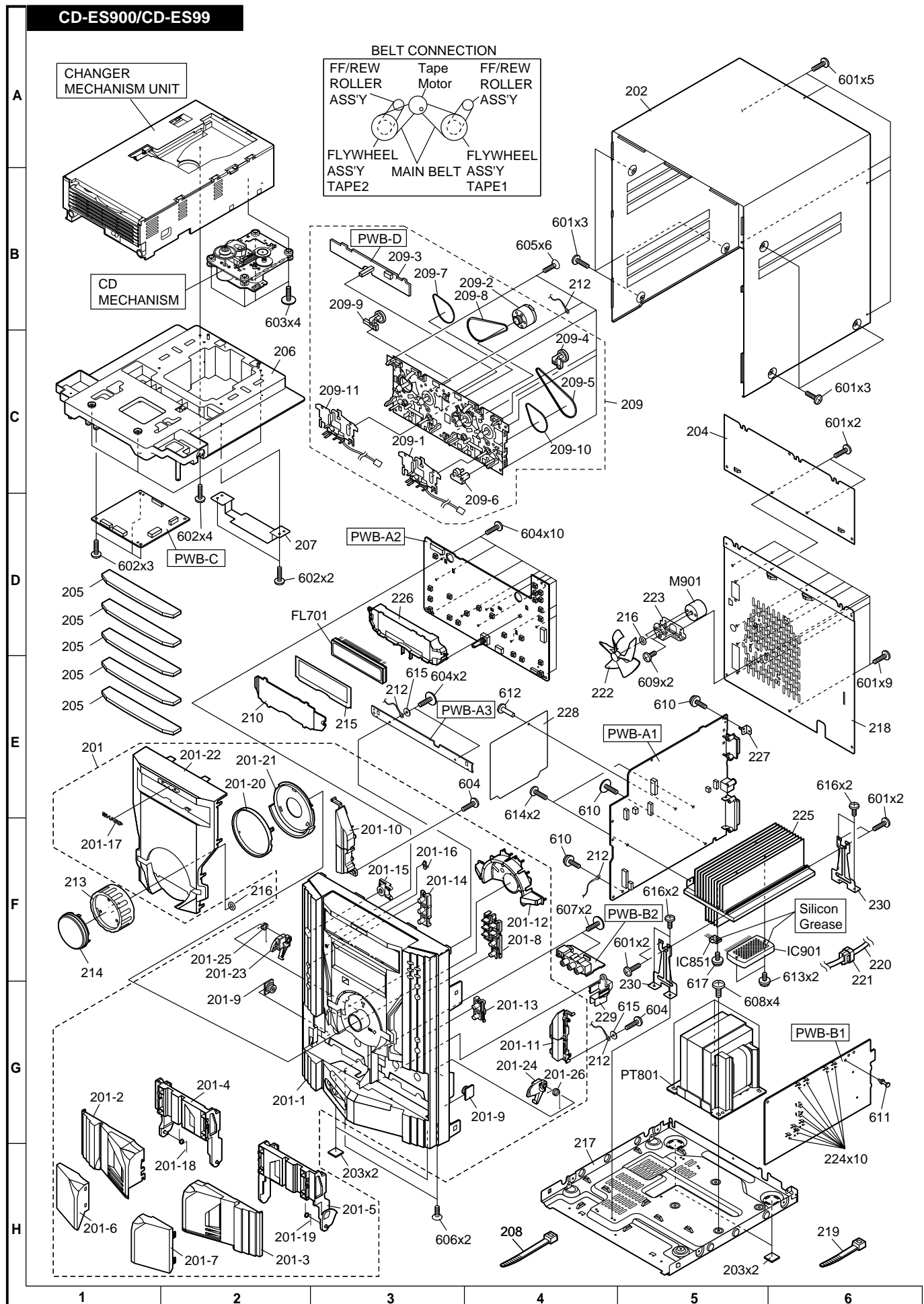

Figure 9 CABINET EXPLODED VIEW

CP-ES900/CP-ES99

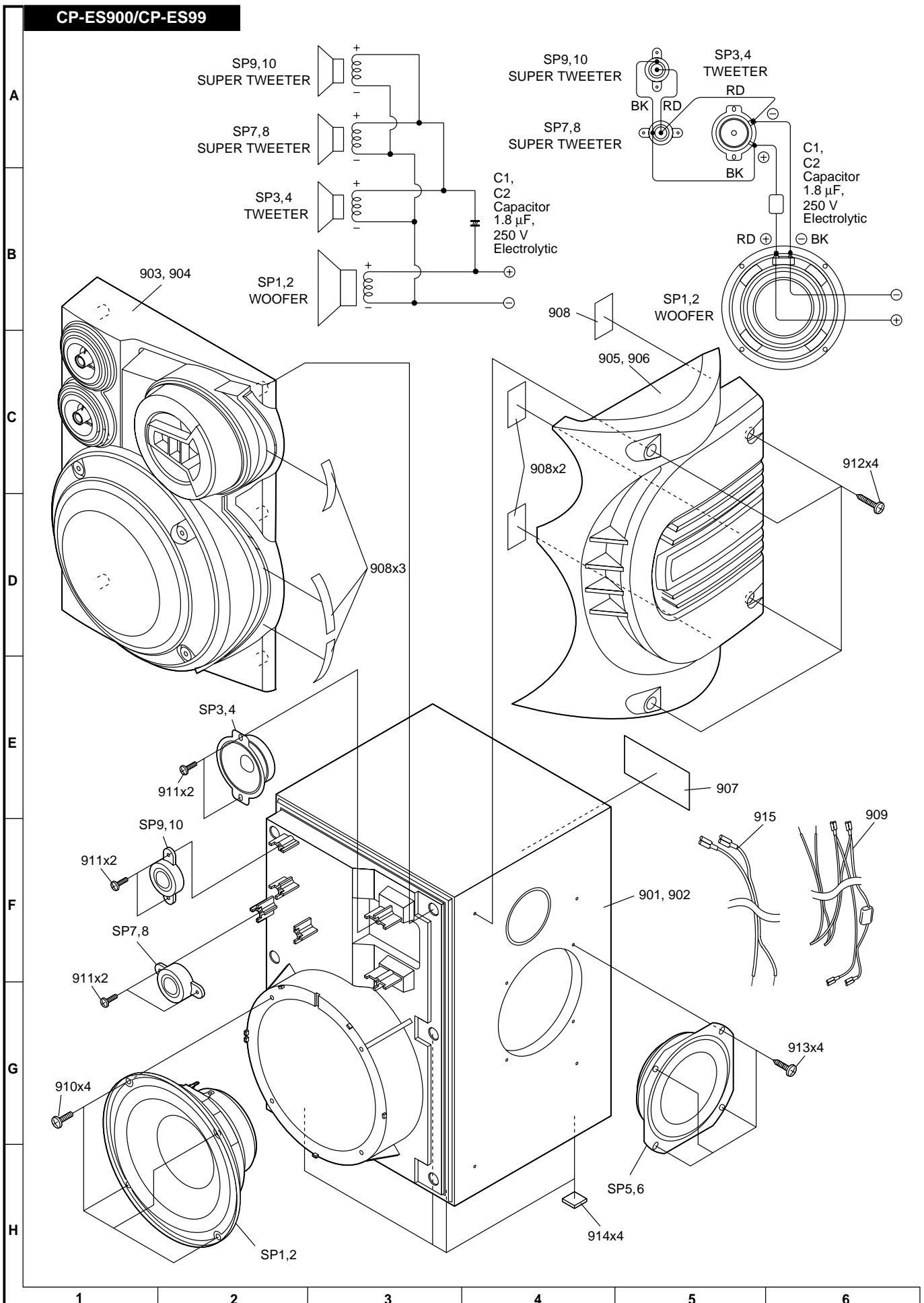

Figure 10 SPEAKER EXPLODED VIEW