

# SHARP SERVICE MANUAL

CODE: 00ZAR161//A1E

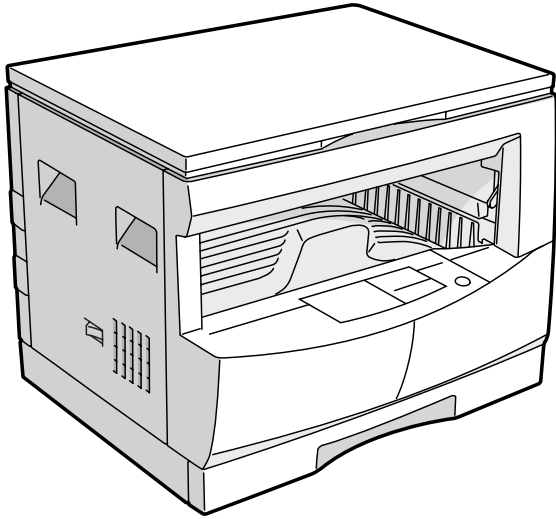

## DIGITAL COPIER

# AR-160 MODEL AR-161

### CONTENTS

[ 1 ] GENERAL .....	1-1
[ 2 ] SPECIFICATIONS .....	2-1
[ 3 ] CONSUMABLE PARTS .....	3-1
[ 4 ] EXTERNAL VIEWS AND INTERNAL STRUCTURE .....	4-1
[ 5 ] UNPACKING AND INSTALLATION .....	5-1
[ 6 ] OPERATIONAL DESCRIPTIONS .....	6-1
[ 7 ] ADJUSTMENTS .....	7-1
[ 8 ] SIMULATIONS .....	8-1
[ 9 ] USER PROGRAM .....	9-1
[10] TROUBLE CODE LIST .....	10-1
[11] MAINTENANCE .....	11-1
[12] DISASSEMBLY AND ASSEMBLY .....	12-1
[13] ELECTRICAL SECTION .....	13-1
[14] CIRCUIT DIAGRAM .....	14-1
[15] ACTUAL WIRING DIAGRAM .....	15-1

Parts marked with "△" is important for maintaining the safety of the set. Be sure to replace these parts with specified ones for maintaining the safety and performance of the set.

**Warning!**

This product is a class A product.

If it is operated in households, offices or similar surroundings, it can produce radio interferences at other appliances, so that the user has to take adequate countermeasures.

CLASS 1 LASER PRODUCT

LASER KLASSE 1

LUOKAN 1 LASERLAITE

KLASS 1 LASERAPPARAT

**VAROITUS!**

LAITTEEN KÄYTTÄMINEN MUULLA KUIN TÄSSÄ KÄYTTÖOHJEESSA MAINITULLA TAVALLA SAATTAA ALTISTAA KÄYTTÄJÄN TURVALLISUUSLUOKAN 1 YLITTÄVÄLLE NÄKYMÄTTÖMÄLLE LASERSÄTEILYLLE.

**VARNING**

OM APPARATEN ANVÄNDS PÅ ANNAT SÄTT ÄN I DENNA BRUKSANVISNING SPECIFICERATS, KAN ANVÄNDAREN UTSÄTTAS FÖR OSYNLIG LASERSTRÅLNING, SOM ÖVERSKRIDER GRÄNSEN FÖR LASERKLASS 1.

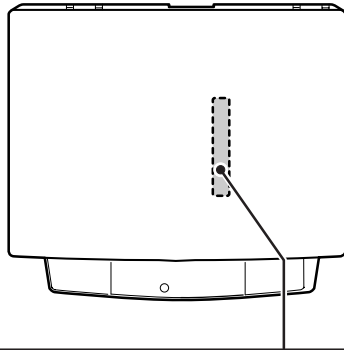

Laserstrahl

**CAUTION** INVISIBLE LASER RADIATION WHEN OPEN AND INTERLOCKS DEFEATED. AVOID EXPOSURE TO BEAM.

**VORSICHT** UNSICHTBARE LASERSTRÄHLUNG WENN ABDECKUNG GEÖFFNET UND SICHERHEITSVERICHELUNG ÜBERÜCKT. NICHT DEM STRAHL AUSSETZEN.

**ADVARSEL** USYNLIG LASERSTRÅLNING VED ÅBNING, NÅR SIKKERHEDSAFBRYDERE ER UDE AF FUNKTION. UNDGÅ UDSÆTTELSE FOR STRÅLING.

**ADVERSEL** USYNLIG LASERSTRÅLNING NÅR DEKSEL ÅPNES OG SIKKERHEDSLÅS BRYTES. UNNGÅ EKSPONERING FOR STRÅLEN.

**VARNING** OSYNLIG LASERSTRÅLNING NÅR DENNA DEL ÄR ÖPPNAD OCH SPÄRRAR ÄR URKOPPLADE. STRÅLEN ÄR FÄRLIG. BETRÄKTA EJ STRÅLEN.

**VARO!** AVATTAESSA JA SUOJALUKITUS OHTETTAESSA OLET ALLTTINA NÄKYMÄTÖNTÄ LASERSÄTEILYLLE. ÄLÄ KÄTÖ SÄTEESEEN.

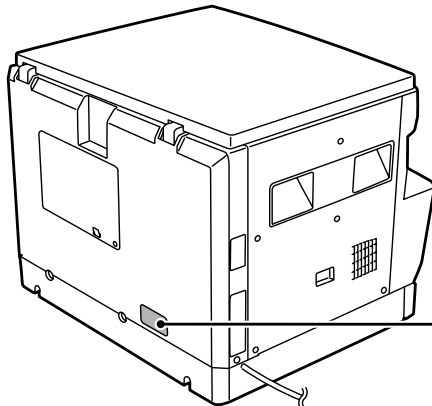

**CLASS 1  
LASER PRODUCT  
LASER KLASSE 1**

# CONTENTS

<b>[ 1 ] GENERAL</b> .....	1-1	<b>[ 7 ] ADJUSTMENTS</b> .....	7-1
1. General .....	1-1	1. Adjustment item list .....	7-1
2. Target user copy volume: Monthly average ...	1-1	2. Copier adjustment .....	7-1
3. Main features .....	1-1	<b>[ 8 ] SIMULATIONS</b> .....	8-1
4. System configuration .....	1-1	1. Entering the simulation mode .....	8-1
5. Copier installation .....	1-1	2. Cancelling the simulation mode .....	8-1
<b>[ 2 ] SPECIFICATIONS</b> .....	2-1	3. List of simulations .....	8-1
1. Copy mode .....	2-1	4. Contents of simulations .....	8-2
<b>[ 3 ] CONSUMABLE PARTS</b> .....	3-1	<b>[ 9 ] USER PROGRAM</b> .....	9-1
1. Supply system table .....	3-1	1. User program functions .....	9-1
2. Environment conditions .....	3-3	2. Setting change procedure .....	9-2
3. Production number identification .....	3-3	3. Department counter setting .....	9-2
4. Consumable parts recycling procedure .....	3-4	<b>[10] TROUBLE CODE LIST</b> .....	10-1
<b>[ 4 ] EXTERNAL VIEWS AND INTERNAL STRUCTURE</b> .....	4-1	<b>[11] MAINTENANCE</b> .....	11-1
1. Appearance .....	4-1	1. Maintenance table .....	11-1
2. Internal .....	4-1	<b>[12] DISASSEMBLY AND ASSEMBLY</b> .....	12-1
3. Operation Section .....	4-2	1. High voltage section .....	12-1
4. Motor, solenoid, clutch .....	4-3	2. Optical section .....	12-1
5. Sensor, switch .....	4-4	3. Fusing section .....	12-2
6. PWB unit .....	4-5	4. Paper exit section .....	12-4
7. Cross sectional view .....	4-6	5. MCU .....	12-6
<b>[ 5 ] UNPACKING AND INSTALLATION</b> .....	5-1	6. Optical frame unit .....	12-6
1. Installation of machine .....	5-1	7. LSU .....	12-6
2. Removal of protective material and fixing screw	5-1	8. Tray paper feed section/ Paper transport section .....	12-7
3. Installation of developing cartridge .....	5-1	9. Manual multi paper feed section .....	12-8
4. Removal and storage of fixing screw .....	5-2	10. Power section .....	12-10
5. Changing the copy paper size in the tray .....	5-3	11. Developing section .....	12-11
<b>[ 6 ] OPERATIONAL DESCRIPTIONS</b> .....	6-1	12. Process section .....	12-12
1. Outline of operation .....	6-1	<b>[13] ELECTRICAL SECTION</b> .....	13-1
2. Scanner section .....	6-1	1. Outline .....	13-1
3. Process section .....	6-2	2. MCU .....	13-2
4. Laser unit .....	6-5	3. CCD PWB .....	13-13
5. Paper feed section .....	6-6	<b>[14] CIRCUIT DIAGRAM</b> .....	14-1
6. Fusing section .....	6-7	<b>[15] ACTUAL WIRING DIAGRAM</b> .....	15-1

## [1] GENERAL

### 1. General

This model is a digital personal copier produced with key words of "Comfort able copy, Clear copy, Easy copy" providing high copy performances and copy productivity.

### 2. Target user copy volume: Monthly average

Stand-alone copier: 2000~3000 sheets

Compound machine: 4000~5000 sheets

### 3. Main features

#### A. High-speed laser copying

- First-copy time is only 7.2 seconds (normal mode).
- Copying speed is 16 copies/min., which adapts to business use, allowing improvement of working efficiency.

#### B. High-quality digital image

- High-quality copying at 600 dpi is performed.
- In addition to the automatic exposure mode, the manual exposure can be adjusted in five steps.
- The photo mode copying function allows clear copying of delicate halftone original images such as monochrome photos and color photos. Photo mode is adjustable in five steps

#### C. Substantial copying features

- Zoom copying from 50% to 200% in 1% increments can be performed.
- Continuous copying of maximum 99 sheets can also be performed.
- Useful special features such as the XY zoom, black and white reverse, and dual page copy are available.
- Toner save mode reduces toner consumption by approximately 10%.
- User programs allow setting/modification of functions for customer needs. Also the user programs allow the internal auditor to be controlled.

#### D. Scan once/ Print many (Only AR-161 for USA/Canada)

- The copier is equipped with a 1-page memory buffer. This memory allows the copier to scan an original 1 time only and make up to 99 copies. This feature allows for improved workflow, reduced operating noise from the copier and reduced wear and tear on the scanning mechanism, which provides for a higher reliability.

#### E. Optional features

- An optional single pass feeder (SPF) allows automatic document feeding of up to 30 sheets.
- An optional electronic sort board allows many useful copier features to be used. Multiple sets of copies can be sorted without the aid of a sorter and each set can be offset from the previous set. Also the erase, margin shift, and 4 in 1 and 2 in 1 functions are available. (To use the 2 in 1 and 4 in 1 and sort/group functions, an optional SPF is also needed.) (Offset only for AR-161)
- This copier can be used as a laser printer by installing an optional printer upgrade kit. (Depends on the destination)
- This copier can be used as a facsimile machine by installing an optional facsimile upgrade kit. (Depends on the destination)

#### F. Environmentally friendly design

- Paper output tray is housed in the copier for space saving.
- Preheat mode and auto power shut-off mode are provided to reduce power consumption in standby mode.

## 4. System configuration

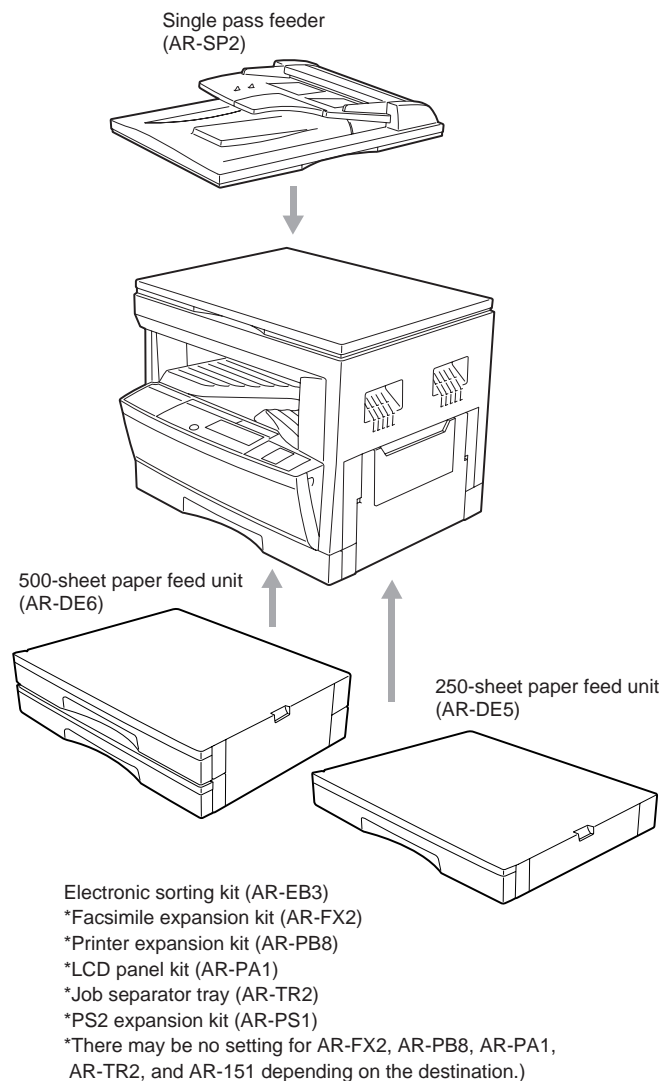

## 5. Copier installation

Do not install your copier in areas that are:

- damp, humid, or very dusty
- exposed to direct sunlight
- poorly ventilated
- subject to extreme temperature or humidity changes, e.g., near an air conditioner or heater.
- Be sure to allow the required space around the machine for servicing and proper ventilation.

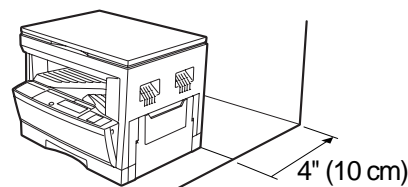



## [2] SPECIFICATIONS

### 1. Copy mode

#### A. Type

Type	Desk-top
------	----------

#### B. Copy speed

##### (1) Basic speed

1 scan 1 copy	16 sheets/min
1 scan multi copy	Not available (Available for AR-161 for USA/Canada)

Condition: Copy speed in the normal copy from all the paper feed ports including the manual paper feed port.

##### (2) Continuous copy speed (Sheets/min)

Paper size		Normal	Enlargement (200%)	Reduction (50%)
AB system	A3	9	9	9
	B4	10	10	10
	A4	16	16	14
	A4R	12	12	12
	B5	16	16	16
	B5R	14	14	14
Inch system	11" × 17"	9	9	9
	8.5" × 14"	10	10	10
	8.5" × 13"	10	10	10
	8.5" × 11"	16	16	14
	8.5" × 11"R	12	12	12
	8.5" × 5.5"	16	16	16

#### C. First copy time

##### (1) Basic speed

First copy time	7.2sec (A4, 8.5" × 11"/1st cassette/with OC)
-----------------	--

#### D. Document

Max. document size	A3, 11" × 17"
Document reference position	Left side center
Detection (Platen)	None
Detection size	A3, B4, A4, A4R, B5, B5R 11" × 17", 8.5" × 14", 8.5" × 13", 8.5" × 11", 8.5" × 11"R, 8.5" × 5.5"

##### (1) SPF/R-SPF

Standard/Option	Option SPF, AR-SP2 RSPF; Not available
Document load capacity	30 sheets (56 ~ 90g/m <sup>2</sup> equivalent)
Document size (Max. ~ Min.)	A3 ~ A5 11" × 17" ~ 8.5" × 5.5"
Document replacement speed	16 sheets/min (A4 normal copy)
Document set/Paper feed direction	Face up, Center reference, Paper feed from the top
Document weight	56 ~ 90g/m <sup>2</sup> , 15 ~ 23.9 lbs
Document size detection	On the document feed tray
Document mixture	Copy mode: Not Available

### E. Paper feed

Copy size	(Max. ~ Min.) Cassette: (A3 ~ A6)	
Paper feed system	1 cassette + Multi manual paper feed	
Paper feed capacity	250 × 1 (Paper feed tray) + 100 (Multi bypass feed tray)(56 ~ 80g/m <sup>2</sup> equivalent)	
Remaining quantity detection	Cassette section	Empty detection available, size detection by key input
	Manual tray	Only empty detection available

##### (1) Paper feed section of the copier

Paper feed size	A3, B4, A4, A4R, B5, B5R, A5 11" × 17", 8.5" × 14", 8.5" × 13", 8.5" × 11", 8.5" × 11"R, 8.5" × 5.5"
Side front	Front 1st step
Paper feed capacity	250 sheets (56 ~ 80g/m <sup>2</sup> equivalent)
Detection	Paper empty detection available, size detection (by key input)
Weight	56 ~ 80g/m <sup>2</sup>
Special paper	Recycled paper

##### (2) Manual paper feed section

Paper feed size	A3 ~ A5
Paper feed capacity	100 sheets
Detection	Size detection not available, paper empty detection available
Weight	56 ~ 128g/m <sup>2</sup>
Special paper	Recycled paper, OHP film, labels
Paper feed	Single except for recycled paper

##### (3) Option paper feed unit

	1-step paper feed unit	2-step paper feed unit
Model	AR-DE5	AR-DE6
Paper feed size	A3, B4, A4, A4R, B5, B5R, A5 11" × 17", 8.5" × 14", 8.5" × 13", 8.5" × 11", 8.5" × 11"R, 8.5" × 5.5"	
Capacity (56 ~ 80g/m <sup>2</sup> )	About 250 sheets × 1 step	About 250 sheets × 2 steps
Paper weight	56 ~ 80 g/m <sup>2</sup>	
Moisture preserving heater	Standard provision	
Detection	Paper empty detection, size detection (by key input)	
Paper size setting	User setting (by key input)	
External dimensions (W × D × H)	570 × 570 × 103mm	570 × 570 × 208mm
Weight	About 8.5kg	About 14kg
Special paper	Recycled paper	
Power	Supplied from the machine (5V/24V)	

#### F. Job speed

S-S (1st step)	100% (document replacement rate)
----------------	----------------------------------

Condition: With SPF

#### G. Multi copy

Max. number of multi copy	99 sheets
---------------------------	-----------

## H. Warmup time

Warmup time	Approx. 35 sec (Condition: Standard condition)
Pre-heat	Available
Jam recovery time	Second (Condition: Left for 60 sec after door open. Standard condition, polygon motor not stopped)
	Second (Condition: Polygon motor stopped)

## I. Copy magnification ratio

Fixed magnification ratio	AB system: 50, 70, 81, 86, 100, 115, 122, 141, 200% Inch system: 50, 64, 77, 95, 100, 121, 129, 141, 200%
Zooming	50 ~ 200%
Independent zooming/vertical	Available (50 ~ 200%)
Independent zooming (horizontal)	Available (50 ~ 200%)

## J. Print density

Density mode	Auto/Manual/Photo
No. of manual adjustment	5 steps (Manual/Photo)
Toner save mode	Set by the user program

## K. Print area

Max. print area	AB system	Max.	416 × 293
		A3	416 × 293
		B4	360 × 253
		A4	206 × 293
		A4R	293 × 206
		B5	178 × 253
		B5R	253 × 178
	Inch system	Max.	428 × 275
		11" × 17"	428 × 275
		8.5" × 14"	352 × 212
		8.5" × 13"	212 × 326
		8.5" × 11"	212 × 275
		8.5" × 11"R	275 × 212
		8.5" × 5.5"	212 × 136

## L. Void width

Void area	Lead edge 1 ~ 4mm, rear edge 4mm or less, both side 4mm or less
Image loss	Max. 4mm in total of lead edge and rear edge, max. 4mm in total of right and left edges (Normal copy)

## M. Auto duplex

Standard/Option	Not installable
-----------------	-----------------

## N. Paper exit/finishing

Paper exit section capacity	Face down 250 sheets
Job separator	Job separator, option (AR-TR2)
	Upper: FAX/Printer, Lower: Copier Upper: 100sheets, Lower 150sheets
Full detection	Available (Job separator upper step)
Finishing	Electronic sort board: Option (AR-EB3)
Electronic sort capacity	A4 standard document 60 sheets
Offset function	AR-161: Available
Staple function	None

### (1) Electronic sort board (Option)

Electronic sort	Sorting	60 sheets of A4 standard documents
	Grouping	60 sheets of A4 standard documents
Rotation copy	If there is paper of same size as the document, the image is rotated to copy even though the paper is set in the different direction from the document direction.	
2 in 1, 4 in 1	Copies of 2 pages or 4 pages are integrated into one surface. Divided by solid lines, (Selectable by the user program.)	
Edge erase	Images surrounding the document are erased when copying. (Adjustable in 0 ~ 20mm by the user program.)	
Center erase	The image at the center is erased when copying. (Adjustable in 0 ~ 20mm by the user program.)	
Margin shift	Binding margin is made at the left edge of the set documents.	

## O. Additional functions

APS*	<input type="radio"/>	(APS not available by flowing in during use of SPF)
AMS*	<input type="radio"/>	(AMS not available by flowing in during use of SPF)
Duplex	<input checked="" type="checkbox"/>	
Document count	<input checked="" type="checkbox"/>	
Sorter	△	When the electronic sort board installed.
Independent zooming	<input type="radio"/>	Vertical/Horizontal: 50 ~ 200%
1 set 2 copy	<input type="radio"/>	Enlargement inhibited, inhibited during the use of SPF
Binding margin	△	Shift width 9mm
Edge erase	△	Width 5mm (Adjustable 0 ~ 20mm)
Black-white reversion	<input type="radio"/>	Whole surface only
2 in 1, 4 in 1	△	
Rotation copy	△	
Memory copy	<input checked="" type="checkbox"/>	(AR-161 for USA/Canada: Available)
Pre-heat function	<input type="radio"/>	Conditions set by the user program
Auto power shut off function	<input type="radio"/>	Conditions set by the user program
Auto tray switching	<input type="radio"/>	
Message display	△	(FAX/Printer extension)
User program	<input type="radio"/>	
Total counter	<input type="radio"/>	

\*: By the document size set key

△: When an option is installed

**P. machine composition**

Model	
AR-160	Standard model
AR-161	Standard model (with shifter) (USA/Canada: with memory copy)

**(1) Option**

Machine	Model	Power supply
250 sheets paper feed unit	AR-DE5	Supplied by the copier.
500 sheets paper feed unit	AR-DE6	Supplied by the copier.
SPF	AR-SP2	Supplied by the copier.
Electronic sorting kit	AR-EB3	Supplied by the copier.
Printer expansion kit	AR-PB8	Supplied by the copier.
Facsimile extension kit	AR-FX2	Supplied by the copier.
LCD panel kit (20 digits × 2 lines)	AR-PA1	Supplied by the copier.
Job separator tray	AR-TR2	
PS2 expansion kit	AR-PS1	
Extension memory for FAX (2MB)	AR-MM5	
Extension memory for FAX (4MB)	AR-MM6	
Extension memory for FAX (8MB)	AR-MM7	

**Q. Other specifications**

Photoconductor type	OPC (Organic Photo Conductor)
Photoconductor drum dia.	30mm
Copy lamp	Xenon lamp
Developing system	Dry 2-component magnetic brush development
Charging system	Saw teeth charging
Transfer system	Non-contact (Corona) electrostatic transfer
Separation system	Natural separation
Fusing system	Heat roller + Separation pawl
Cleaning system	Contact blade

**R. Package form**

Body	Body/Accessories
------	------------------

**S. External view**

External dimensions (W × D × H)	590 × 531 × 467 mm
Occupying area (W × D)	590 × 531mm (When the manual tray is installed.)
Weight	About 34.1kg

**T. Power source**

Voltage	AC120V, 220V, 240V ± 15%
Frequency	50/60Hz common

**U. Power consumption**

Max. power consumption	About 1.3KWh
------------------------	--------------

\* EnergyStar standard (The second level conformity)

Pre-heat	About 60Wh
Auto power shut off	About 4.8Wh

**V. Reliability**

Target users	Stand-alone copier	Monthly average 2,000 ~ 3,000 copies
	Compound machine	Monthly average 4,000 ~ 5,000 copies

**W. Noise**

Noise	BA standard
-------	-------------

**X. Digital performance**

Resolution	Reading	400 dpi
	Writing	600 dpi
Gradation	Reading	256 gradations
	Writing	Binary

### [3] CONSUMABLE PARTS

#### 1. Supply system table

##### A. USA, CANADA

NO	Name	Content	Life	Product name of other company	Package	Remark
1	Developer cartridge (Black)	Toner/developer cartridge (Toner 610g, Developer 395g) × 1 Vinyl bag × 1	15K	AR-200TD (*1 AR-200TD-J)	4	Life setting by A4 6% document
2	Drum cartridge	Drum cartridge × 1 Vinyl bag × 1	30K	AR-200DR (*1 AR-200DR-J)	4	
3	Toner kit (Black)	Toner bottle (Toner 610g) × 10 Charging hose × 1 Toner cap × 10	150K	AR-200MT (*1 AR-200MT-J)	1	Life setting by A4 6% document
4	Waste toner box	Waste toner box × 10		AR-200TB	1	
5	Developer kit (Black)	Toner bottle (Developer 395g) × 10 Developer cap × 10 DV blade × 10	150K	AR-200MD (*1 AR-200MD-J)	1	
6	Protective cover	MG cover × 10		AR-200MG	1	
7	Drum kit	Drum × 1 Drum fixing plate	30K	AR-200MR (*1 AR-200MR-J)	10	
8	Blade kit	Blade × 10 Mocket (F/R) Each × 10		AR-200CB	1	

\* 1 Production in China for USA

Note: Maintenance parts other than mentioned above must be ordered through the parts department using the proper part number.

##### B. Asia, Southeast Asia

NO	Name	Content	Life	Product name of other company	Package	Remark
1	Developer cartridge (Black)	Toner/developer cartridge (Toner 610g, Developer 395g) × 1 Vinyl bag × 1	15K	AR-200TD	4	Life setting by A4 6% document
2	Drum cartridge	Drum cartridge × 1 Vinyl bag × 1	30K	AR-200DR	4	
3	Toner kit (Black)	Toner bottle (Toner 610g) × 10 Charging hose × 1 Toner cap × 10	150K	AR-200CT	1	Life setting by A4 6% document
4	Waste toner box	Waste toner box × 10		AR-200TB	1	
5	Developer kit (Black)	Toner bottle (Developer 395g) × 10 Developer cap × 10 DV blade × 10	150K	AR-200CD	1	
6	Protective cover	MG cover × 10		AR-200MG	1	
7	Drum kit	Drum × 1 Drum fixing plate	30K	AR-200CR	10	
8	Blade kit	Blade × 10 Mocket (F/R) Each × 10		AR-200CB	1	

Note: Maintenance parts other than mentioned above must be ordered through the parts department using the proper part number.

**C. Europe / Australia / New Zealand / Middle East / Africa / CIS**

NO	Name	Content	Life	Product name of other company	Package	Remark
1	Developer cartridge (Black)	Toner/developer cartridge × 1 (Toner 610g, Developer 395g) Vinyl bag × 1	15K	AR-200DC	4	Life setting by A4 6% document
2	Drum cartridge	Drum cartridge × 1 Vinyl bag × 1	30K	AR-200DM	4	
3	Toner kit (Black)	Toner bottle (Toner 610g) × 10 Charging hose × 1 Toner cap × 10	150K	AR-200LT	1	Life setting by A4 6% document
4	Waste toner box	Waste toner box × 10		AR-200TB	1	
5	Developer kit (Black)	Toner bottle (Developer 395g) × 10 Developer cap × 10 DV blade × 10	150K	AR-200LD	1	
6	Protective cover	MG cover × 10		AR-200MG	1	
7	Drum kit	Drum × 1 Drum fixing plate	30K	AR-200LR	10	
8	Blade kit	Blade × 10 Mocket (F/R) Each × 10		AR-200CB	1	

**D. Hong Kong / China**

NO	Name	Content	Life	Product name of other company	Package	Remark
1	Developer cartridge (Black)	Toner/developer cartridge × 1 (Toner 610g, Developer 395g) Vinyl bag × 1	15K	AR-200TD-C	4	Life setting by A4 6% document
2	Drum cartridge	Drum cartridge × 1 Vinyl bag × 1	30K	AR-200DR-C	4	
3	Toner kit (Black)	Toner bottle (Toner 610g) × 10 Charging hose × 1 Toner cap × 10	150K	AR-200CT-C	1	Life setting by A4 6% document
4	Waste toner box	Waste toner box × 10		AR-200TB-C	1	
5	Developer kit (Black)	Toner bottle (Developer 395g) × 10 Developer cap × 10 DV blade × 10	150K	AR-200CD-C	1	
6	Protective cover	MG cover × 10		AR-200MG-C		
7	Drum kit	Drum × 1 Drum fixing plate	30K	AR-200CR-C	10	
8	Blade kit	Blade × 10 Mocket (F/R) Each × 10		AR-200CB-C	1	

Note: Maintenance parts other than mentioned above must be ordered through the parts department using the proper part number.

## 2. Environment conditions

### A. Transport condition

#### (1) Transport conditions

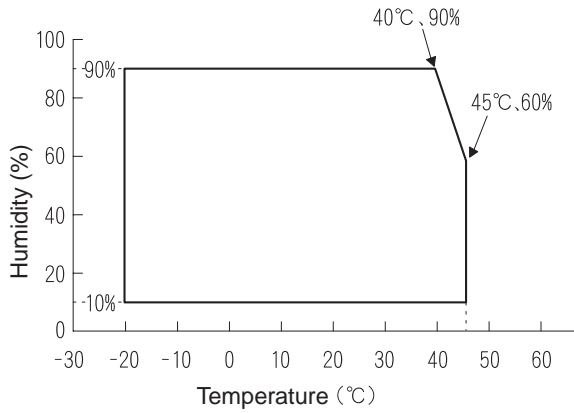

#### (2) Storage conditions (packed conditions)

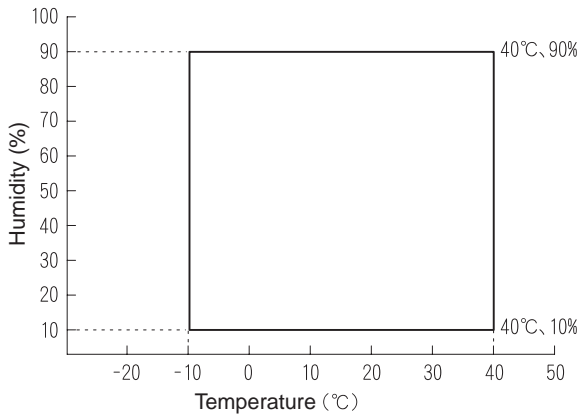

### B. Use conditions

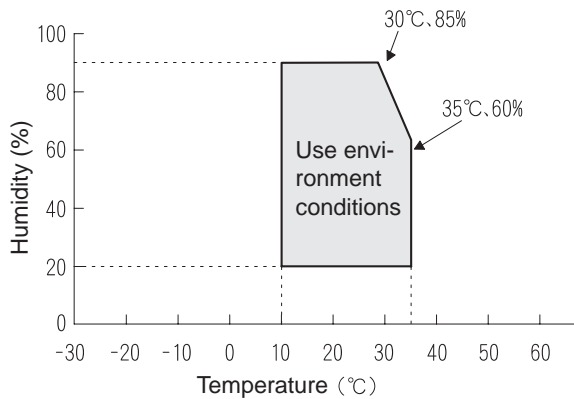

### C. Life (packed conditions)

Photoconductor drum (36 months from the production month)  
 Developer, toner (24 months from the production month)

## 3. Production number identification

### <TD cartridge>

The label on the drum cartridge shows the date of production.

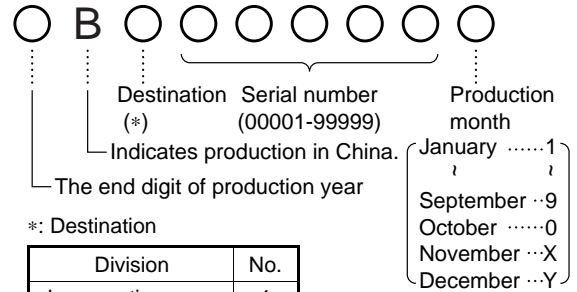

\*: Destination

Division	No.
Japan option	1
Ex option	2
Japan, same pack	6
Ex, same pack	7

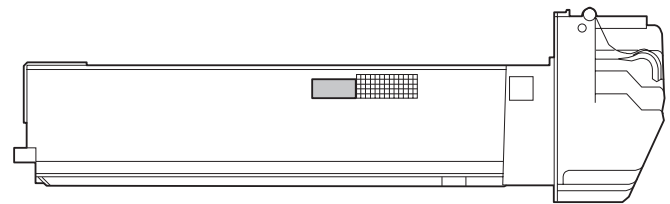

### <Drum cartridge>

The label on the drum cartridge shows the date of production.

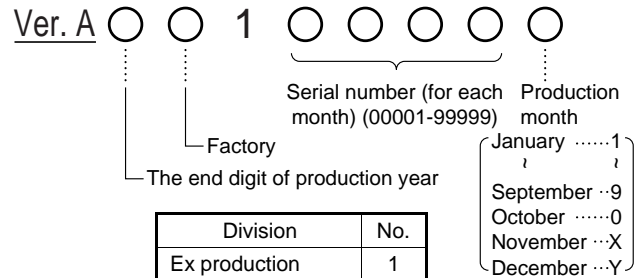

Division	No.
Ex production	1
Option	2
Same pack	3

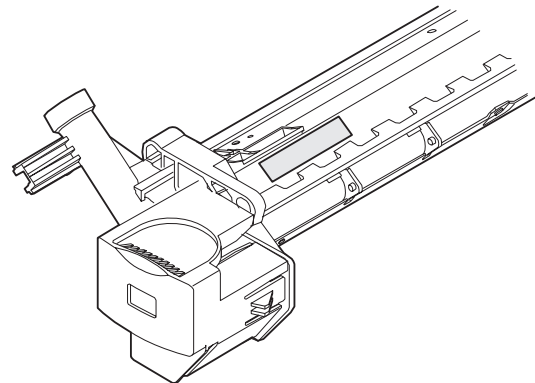

## 4. Consumable parts recycling procedure

### A. TD cartridge

1) Check the external view.

Note: Be careful especially of breakage of the pins and the ATC sensor connector shown below.

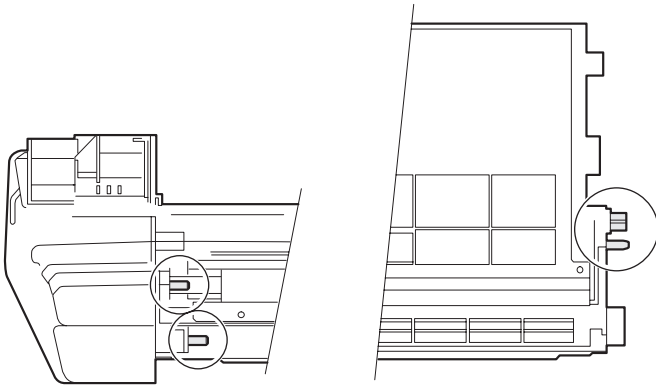

2) Remove the waste toner box unit.

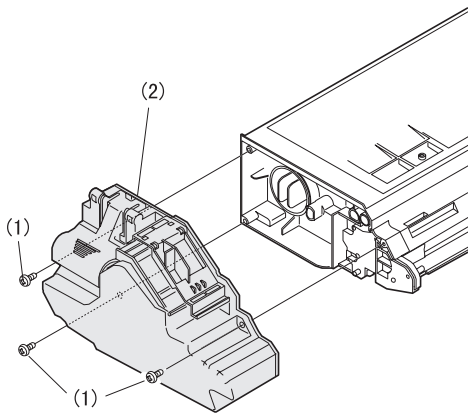

3) Remove the developing unit.

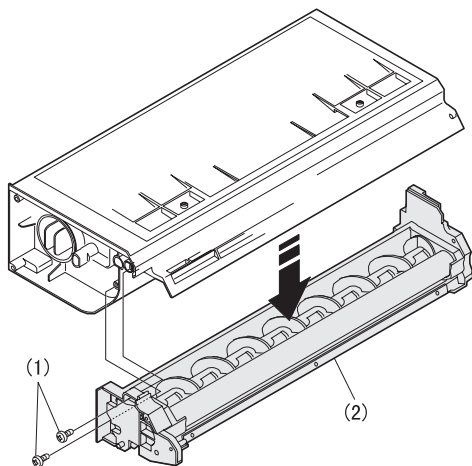

4) Remove the DV blade.

Note: Be sure to remove adhesive completely.  
Remove adhesive together with the base PET.

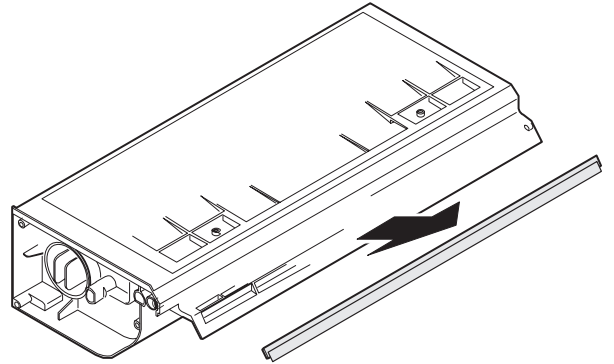

5) Tilt the developing unit, rotate the DV gear clockwise, and remove developer.

6) Clean and remove developer on the MG roller and toner on the developing doctor completely with a vacuum cleaner or an air blower.

7) Shake the developer bottle about 10 times and supply developer to the developing unit.

Turn the stirring roller to distribute developer evenly.

8) Install the toner box.

9) Shake the toner bottle about 20 times and install the toner supply hose to the toner bottle.

10) Remove the toner cap. While visually inspecting from the toner supply port, stop the TH shaft at the vertical position. (The TH mylar is on the lower side.) (Turn the gear on the back of the toner box counterclockwise to set the TH mylar on the lower side.)

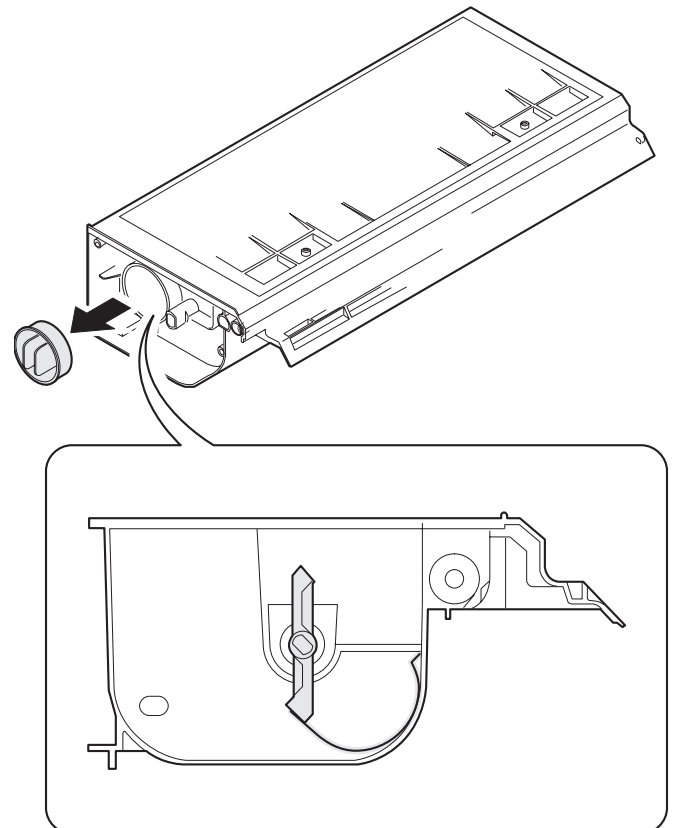

- 11) Face the toner supply port of the toner box upward with the toner bottle put straight, and insert the supply hose into the toner supply port.

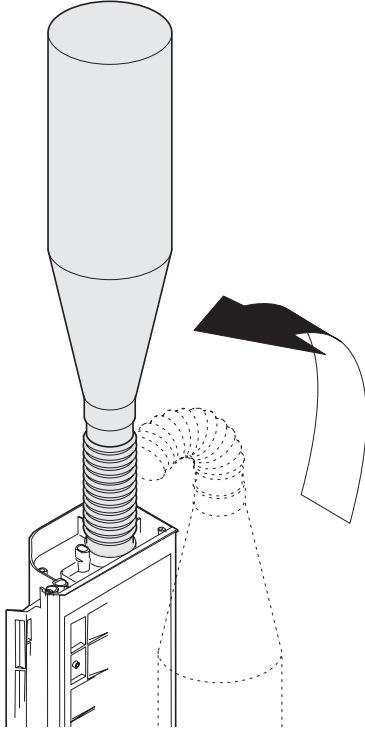

- 12) Lift the toner bottle and supply toner.  
 13) Remove the supply hose from the toner box with care not to spill toner, and attach the toner cap.  
 Note: If the toner cap is not attached properly, toner splash may occur.  
 14) Install the waste toner box.  
 15) Check the operations of the DV lever and the toner box shutter.  
 16) Wipe and clean the developer unit with alcohol, and attach the DV blade to it.

- (Note)
- Dry alcohol completely before attaching the DV blade,
  - When attaching the DV blade, be careful not to scratch it and eliminate slack.
  - After attaching, be careful not to scratch and damage the DV blade.

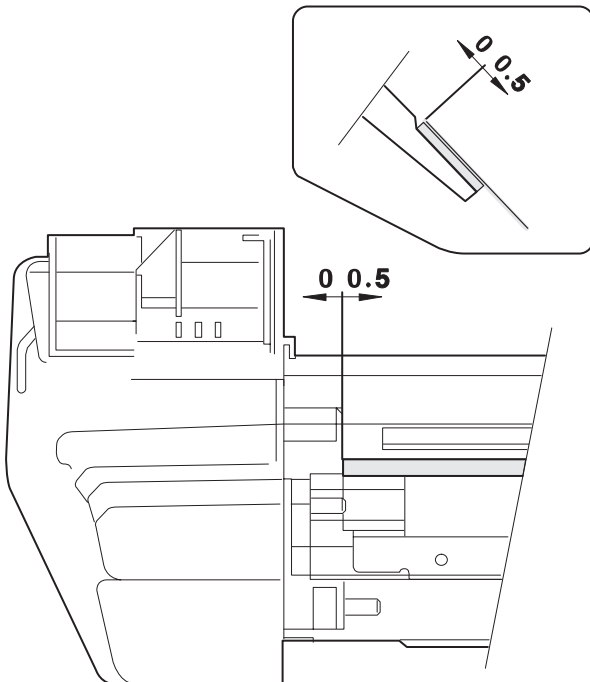

- 17) Shake the developing unit 5 times left and right horizontally.  
 18) Check the distribution state of developer on the MG roller. Rotate the MG roller and visually check for no improper distribution of developer which may be caused by foreign materials.  
 19) Mark the number of times of recycling on the back of the toner box with white paint.  
 Max. times of recycling: 5 times

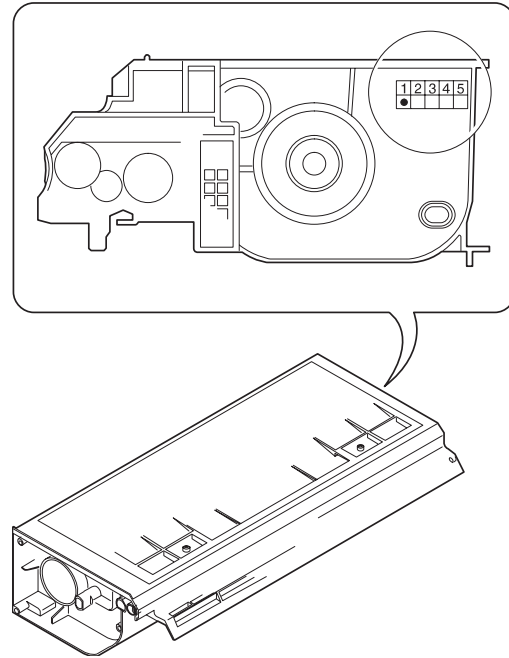

## B. Drum unit

- 1) Check the external view.
- Check for damage or cracks on the boss and the boss hole.
  - Check to insure that the waste toner pipe shutter slides smoothly.
  - Check to insure that the start ring and the CRU washer rotate smoothly.

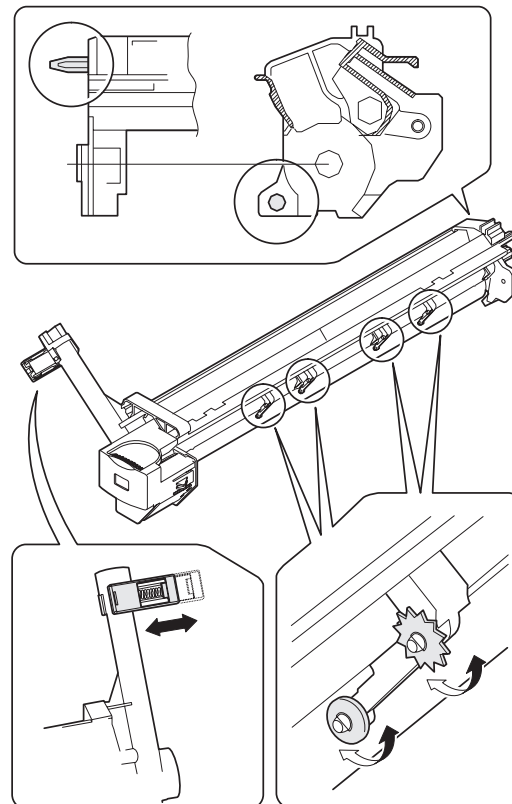



2) Remove the drum cover.

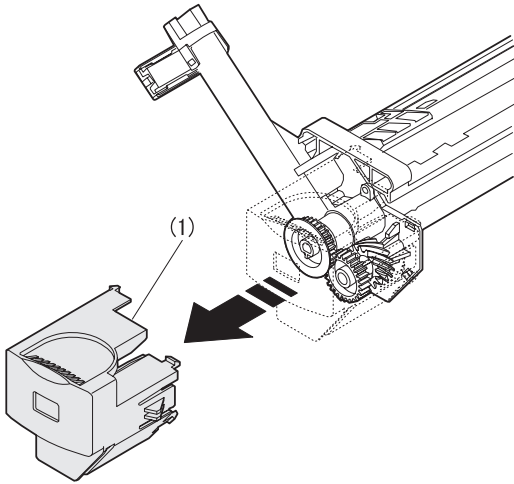

3) Remove the drum fixing plate and the photoconductor drum.  
(Note) Dispose the drum fixing plate which was removed.

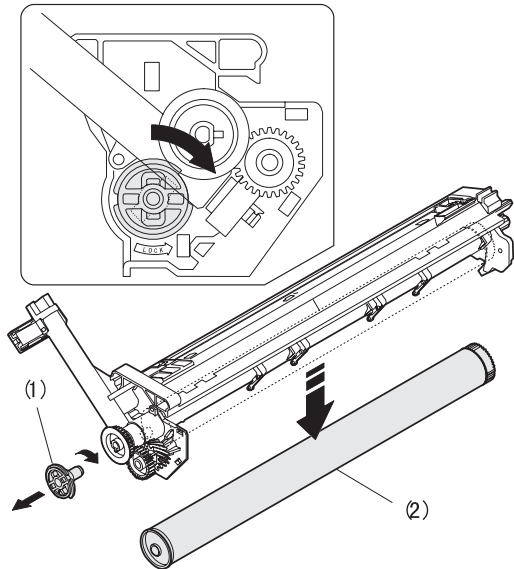

4) Check the cleaning blade and the red felt for no damage.

- If there is any damage, execute all procedures from item 5) and later.
- If there is no damage, execute the procedure of item 12).

5) Remove the main charger.  
(Cleaning the screen grid and the sawteeth.)

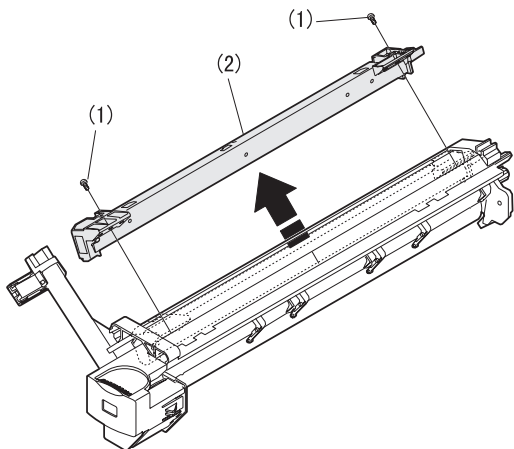

6) Remove the cleaning blade.

Note: Dispose the cleaning blade which was removed.

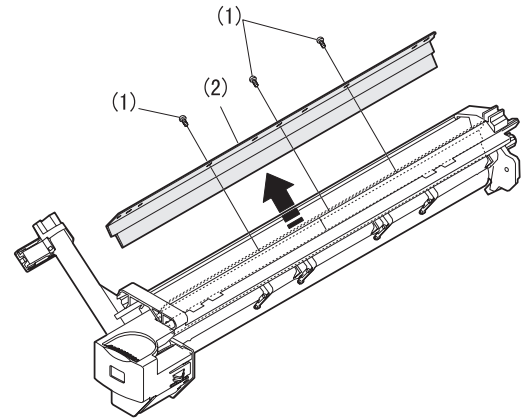

7) Clean the cleaning section and the waste toner pipe to remove waste toner completely with a vacuum cleaner.  
8) Remove the felt and duplex tape completely.  
Note: Be careful not to scratch or bend the sub blade.  
9) Attach the cleaning blade.  
10) Attach the felt.

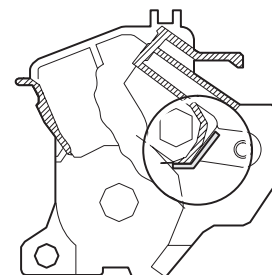
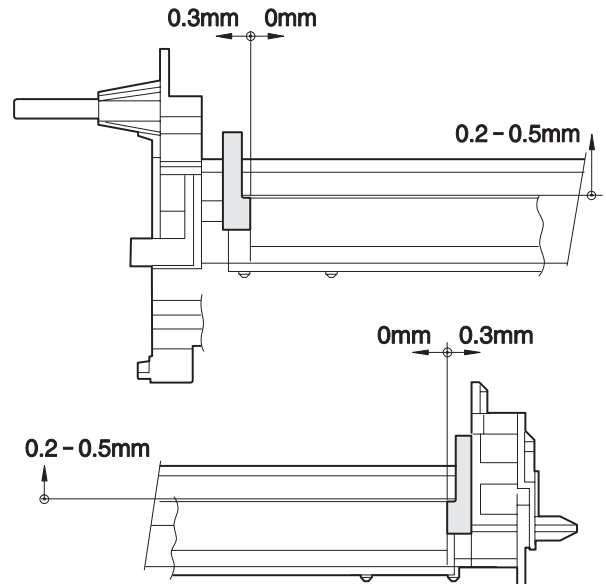

- 11) Attach the main charger.
- 12) Attach the drum fixing plate and the photoconductor drum.  
Apply grease to the inside of the photoconductor drum. (Dia. 2)
- 13) Attach the detection gear.

Note: • The detection gear is not installed to the drum cartridge packed with the main body. Add a new one.

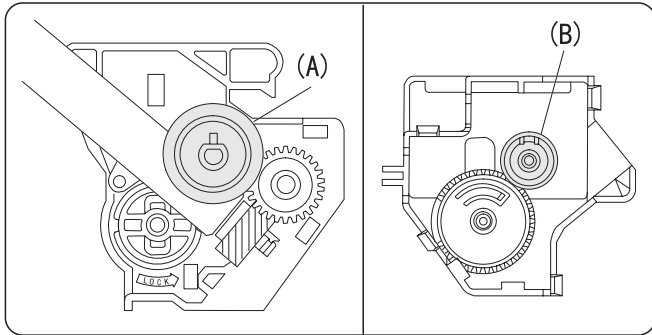

- 14) Attach the drum cover.

Note: After attaching the drum cover, do not make a copy.

- 15) Mark the number of times of recycling on the side of the cover with white paint.

Max. times of recycling: 5 times

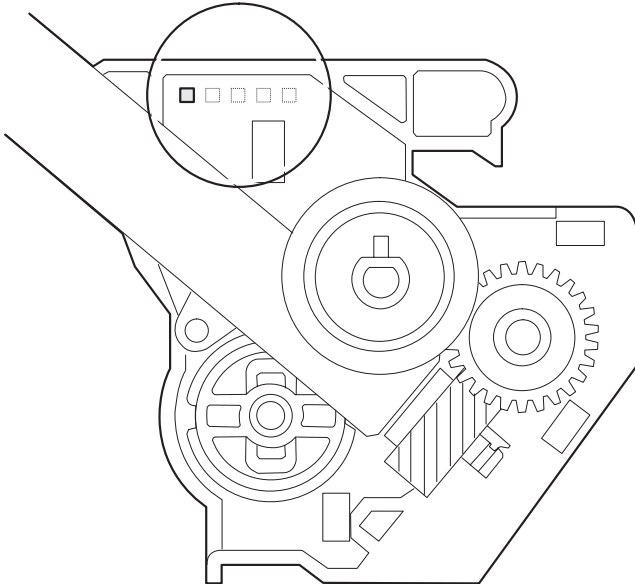

## [4] EXTERNAL VIEWS AND INTERNAL STRUCTURES

### 1. Appearance

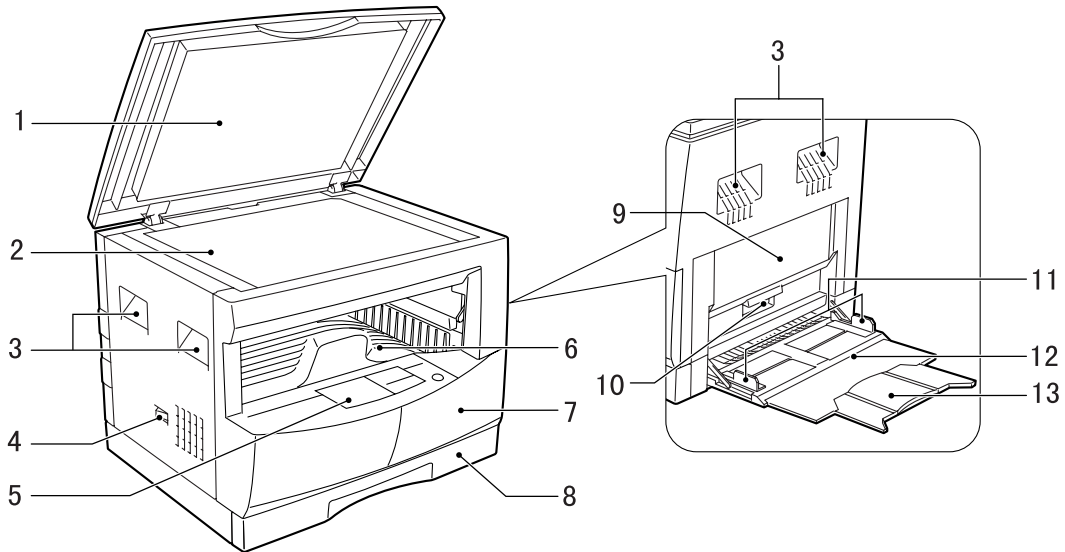

1	Original cover	2	Original table (OC table)	3	Handles
4	Power switch	5	Operation panel	6	Paper output tray
7	Front cover	8	Paper tray	9	Side cover
10	Side cover handle	11	Bypass tray guides	12	Bypass tray
13	Bypass tray extension				

### 2. Internal

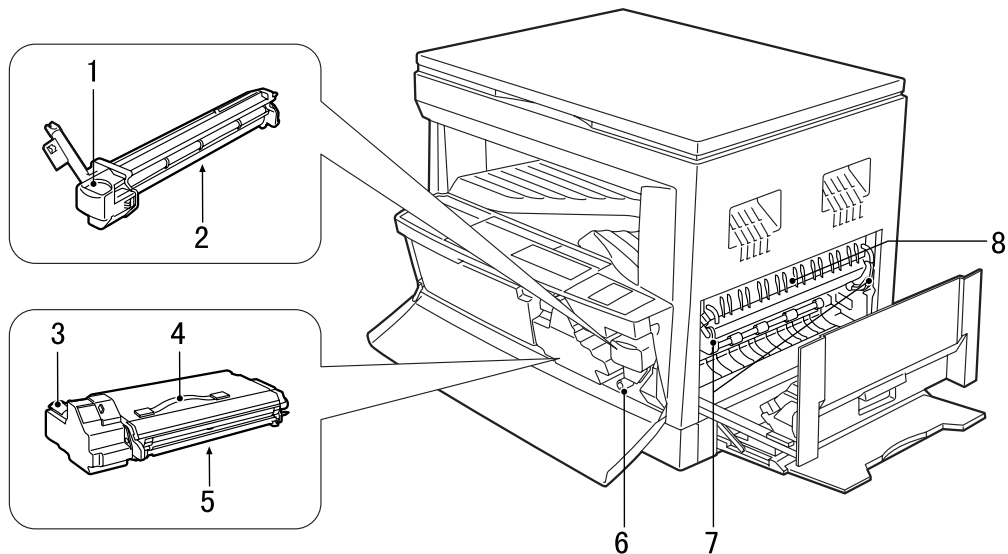

1	Drum cartridge handle	2	Drum cartridge	3	TD cartridge handle
4	TD cartridge strap	5	TD cartridge	6	Roller rotating knob
7	Fusing unit release levers	8	Paper guide		

### 3. Operation Section

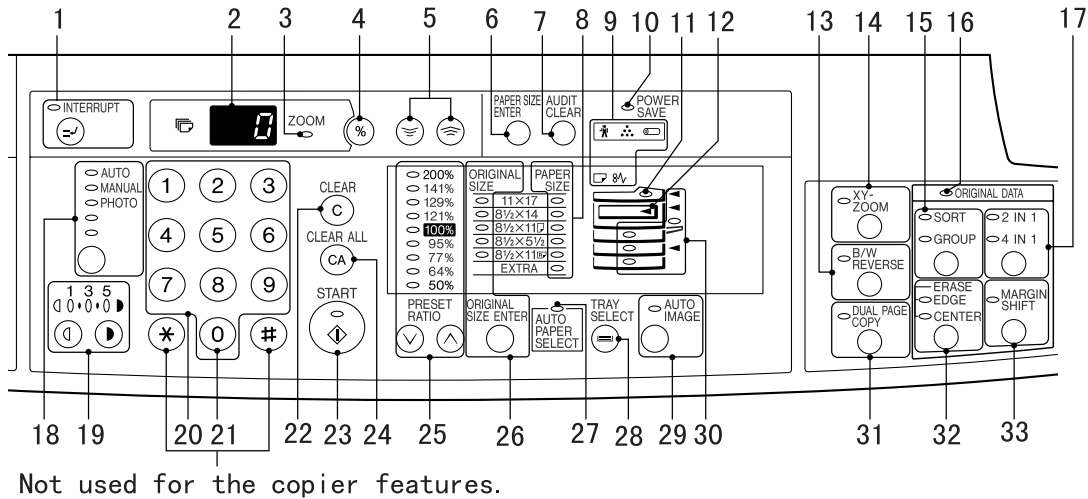

1	Interrupt key and indicator	2	Copy quantity display	3	ZOOM indicator
4	Copy ratio display key	5	Zoom keys	6	PAPER SIZE ENTER key
7	AUDIT CLEAR key	8	PAPER SIZE indicators	9	Alarm indicators
10	POWER SAVE indicator	11	SPF indicator	12	Output tray full indicator
13	B/W REVERSE key and indicator	14	XY-ZOOM key and indicator	15	SORT/GROUP key and indicators
16	ORIGINAL DATA indicator	17	2 IN 1 / 4 IN 1 key and indicators	18	AUTO/MANUAL/PHOTO key and indicators
19	Light and dark keys and indicators	20	Numeric keys	21	Zero key
22	CLEAR key	23	START key and indicator	24	CLEAR ALL key
25	PRESET RATIO selector keys and indicators	26	ORIGINAL SIZE ENTER key and indicators	27	AUTO PAPER SELECT indicator
28	TRAY SELECT key	29	AUTO IMAGE key and indicator	30	Paper feed location/misfeed location indicators
31	DUAL PAGE COPY key and indicator	32	ERASE key and indicators	33	MARGIN SHIFT key and indicator

- \* 1
- ON: Indicates that the machine is in the energy saving (pre-heat) mode.
  - Blink: Indicates that the machine is in the process of resetting from the energy saving mode or just after supplying the power. (During warmup)
  - OFF: Indicates that resetting from the energy saving mode is completed and that the fusing temperature is in ready state.

The combinations of the above display lamps are as follows:  
 (○ = ON, ● = OFF)

Lamp	Immediately after power ON	Ready	Copying
Pre-heat lamp	Blink	●	●
Ready lamp	●	○	●
Other lamps	○	○	○

Lamp	Energy saving mode (Pre-heating)	Energy saving mode (Auto power shut off)	Resetting from energy saving mode	Copy is started during resetting from energy saving mode
Pre-heat lamp	○	○	Blink	Blink
Ready lamp	○	●	○	●
Other lamps	○	●	○	○

- \* 2
- Maintenance lamp  
When the set count number (set by the simulation) is reached, the lamp lights up. The machine does not stop.
  - TD cartridge replacement required indicator  
When toner density is lower than a specified level, the TONER DEVELOPER CARTRIDGE REPLACEMENT indicator lights up to warn the user.  
If toner is not added after approximately 10 sheets are copied, the indicator starts blinking and machine starts to supply toner. (Toner Developer cartridge replacement indicator keeps lighting up)  
If toner density is not back to specific level after two minutes, the READ indicator goes out and Toner Developer indicator starts blinking, and the copier stops.
  - Photoconductor cartridge replacement lamp  
When the copy count reaches 29,000 after installing a Photoconductor cartridge, the lamp lights up.  
When 1,000 copy is made after that, the lamp blinks instead of lighting. The machine does not stop.  
Press and hold the clear key for 5 sec in the user simulation mode to display the remaining life of the photoconductor cartridge in 3 digits x 2 lines on the copy quantity display.
  - Paper required indicator
  - Misfeed indicator

#### 4. Motor, solenoid, clutch

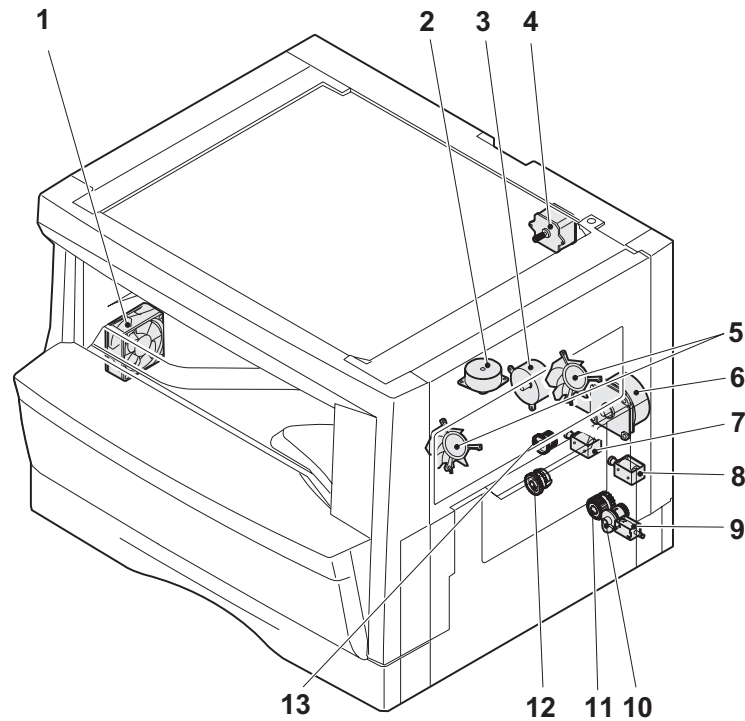

No.	Name	Code	Function, operation
1	Exhaust fan motor	VFM	Cools the inside of the machine.
2	Shifter motor		Shifts the paper exit tray. (AR-161)
3	Toner motor	TM	Toner supply
4	Mirror motor	MRM	Drives the optical mirror base (scanner unit).
5	Cooling fan motor	CFM	Cools the inside of the machine.
6	Main motor	MM	Drives the machine.
7	Paper feed solenoid	CPFS1	Solenoid for paper feed from cassette
8	Resist roller solenoid	RRS	Resist roller rotation control solenoid
9	Manual paper feed solenoid	MPFS	Manual paper feed solenoid
10	Manual paper transport clutch	MPTC	Drives the manual paper transport roller.
11	Manual paper feed clutch	MPFC	Drives the manual paper feed roller.
12	Paper feed clutch	CPFC1	Drives the cassette paper feed roller.
13	PS clutch	RRC	Drives the resist roller

## 5. Sensor, switch

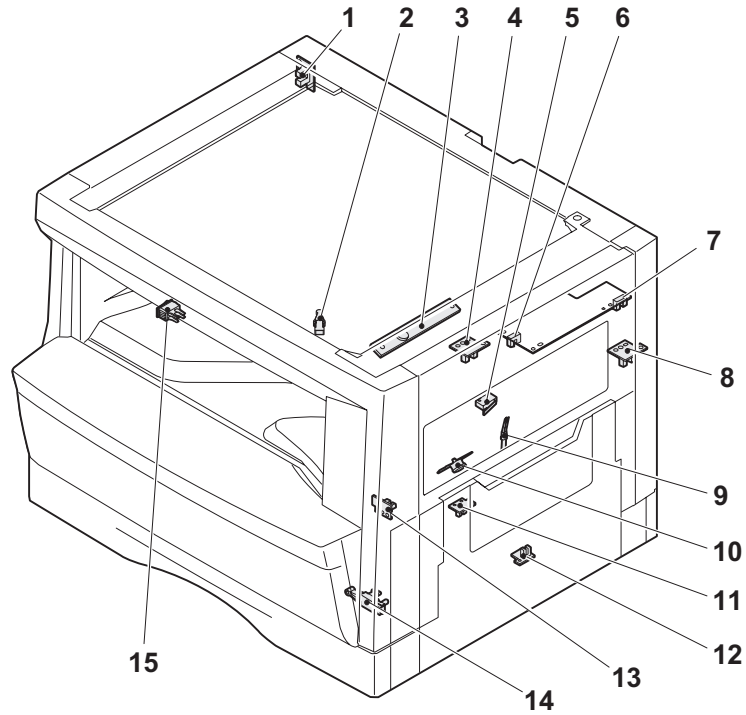

No.	Name	Code	Function, operation
1	Mirror home position sensor	MHPS	Detects the mirror (scanner unit) home position.
2	Cassette detection switch	CSD1	Cassette detection
3	Toner density sensor	TCS	Toner quantity detection
4	Paper exit sensor (paper exit side)	POD1	Detects paper exit.
5	Right door switch	DSWR	Side door open/close detection
6	Paper full sensor		Paper exit tray section full detection <For JOB separator>
7	Lift sensor		Paper feed tray lift up detection <For JOB separator>
8	Paper exit sensor (DUP side)	POD2	Paper transport detection
9	Thermistor		Fusing section temperature detection
10	Thermostat		Fusing section abnormally high temperature detection
11	Paper transport sensor	PPD	Paper transport detection
12	Manual sensor	MPED	Manual transport detection
13	Cassette paper sensor	PED1	Cassette paper empty sensor
14	Drum reset switch	DRST	New drum detection switch
15	Power switch	MAIN SW	Turns ON/OFF the main power source.

## 6. PWB unit

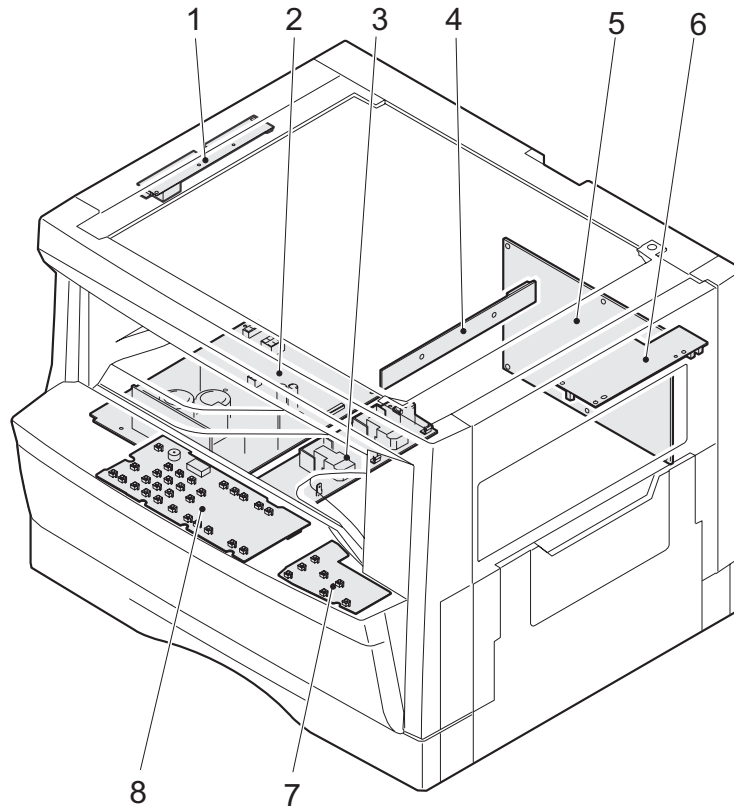

No.	Name	Function, operation
1	Copy lamp inverter PWB	Copy lamp control
2	Power PWB	AC power input/DC power control
3	High voltage PWB	High voltage control
4	CCD sensor PWB	Image scanning
5	Main PWB (MCU)	Machine control/Image process
6	Paper exit interface PWB	Paper exit, finishing control
7	Electronic sort function	Operation panel input/Display
8	Operation main PWB	Operation panel input/Display, operation panel section control

## 7. Cross sectional view

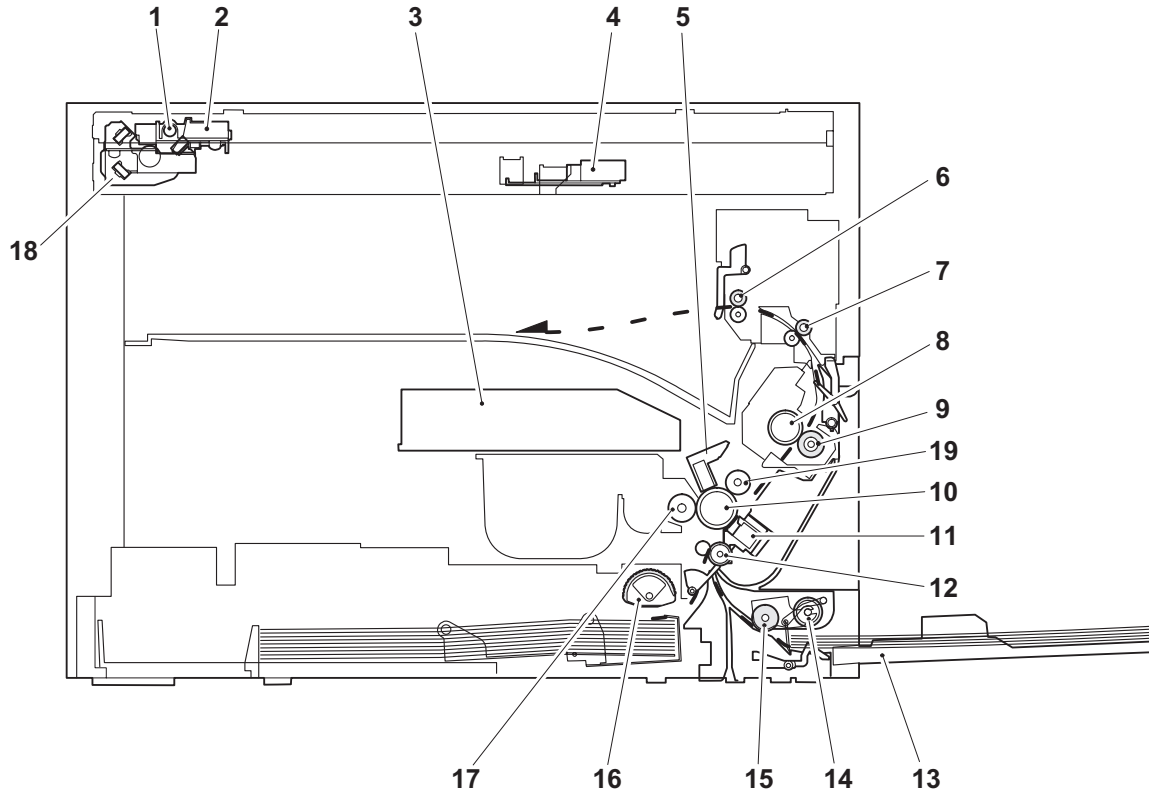

No.	Name	Function/Operation
1	Copy lamp	Image radiation lamp
2	Copy lamp unit	Operates in synchronization with No. 2/3 mirror unit to radiate documents sequentially.
3	LSU unit	Converts image signals into laser beams to write on the drum.
4	Lens unit	Reads images with the lens and the CCD.
5	MC holder unit	Supplies negative charges evenly on the drum.
6	Paper exit roller	Used to discharge paper.
7	Transport roller	Used to transport paper.
8	Upper heat roller	Fuses toner on paper (with the teflon roller).
9	Lower heat roller	Fuses toner on paper (with the silicon rubber roller).
10	Drum unit	Forms images.
11	Transfer charger unit	Transfer images (on the drum) onto paper.
12	Resist roller	Takes synchronization between the paper lead edge and the image lead edge.
13	Manual paper feed tray	Manual paper feed tray
14	Manual paper feed roller	Picks up paper in manual paper feed.
15	Manual transport roller	Transports paper from the manual paper feed port.
16	Paper feed roller (semi-circular roller)	Picks up paper from the cassette.
17	MG roller	Puts toner on the OPC drum.
18	No. 2/3 mirror unit	Reflects the images from the copy lamp unit to the lens unit.
19	Waste toner transport roller	Transports waste toner to the waste toner box.



## [5] UNPACKING AND INSTALLATION

### 1. Installation of machine

#### A. Installing conditions

Since the machine performance is largely affected by the installing place conditions, take enough considerations on the following items

##### 1) Environment

- Avoid installation at a place with direct sunlight. If not, the plastic parts may be deformed.
- Avoid installation near a heater, a humidifier, or an air conditioner where humidity and temperature are extremely high or low. If not, paper may be dampened and dew is formed inside the machine, causing paper jam or dirty copies.
- Avoid installation at a dusty place. If dust enters the machine, dirty copy or a trouble may be caused.
- Avoid installation at a place with vibrations. If not, a machine trouble may be caused.
- Avoid installation at a poorly ventilated place.
- Avoid installation at a place that is filled with ammonium gas. If the copier is installed near a diazo-copier, dirty copies may be resulted.

##### 2) Space around the copier

- Allow a space of more than between the copier rear side and the wall.

##### 3) Power source

- Use an exclusive-use power outlet of 15A and 100V or more. If the power plug of this machine is inserted into a power outlet commonly used with other illumination units, flickers of the lamp may be resulted. Use a power outlet which is not used commonly with any illumination units.
- Avoid complex wiring.

##### 4) Grounding wire connection.

- To avoid danger, be sure to connect a grounding wire. If no grounding wire is connected and a leakage occurs, a fire or an electric shock may be resulted.

### 2. Removal of protective material and fixing screw

- 1) Remove all tapes and protective material.
  - Remove all tapes, then open the document cover and remove the protective material of sheet shape
- 2) Remove the fixing screw.
  - Use a coin to remove the fixing screw.
  - The fixing screw is required when transporting the machine. Keep it in the tray. (Refer to the later description.)

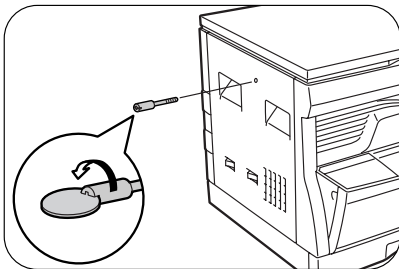

### 3. Installation of developing cartridge

- 1) Open the manual paper feed tray.

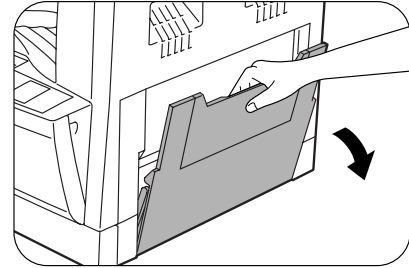

- 2) Lift the knob and slide the side cover gently.

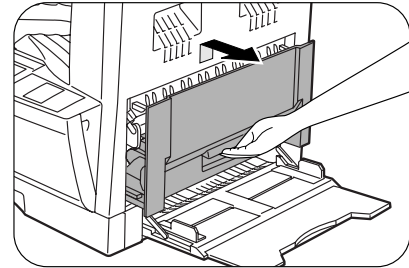

- 3) Open the front cover.
  - Hold the both edge gently and open the front cover.

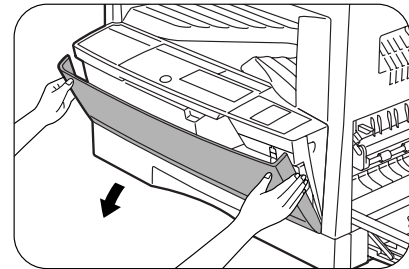

- 4) Remove the screw from the upper section of the insertion port of the developer cartridge.

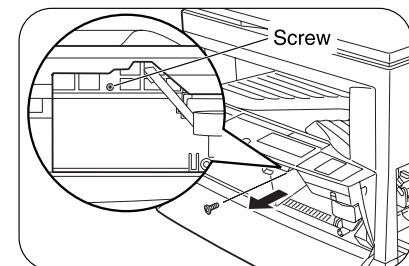

- 5) Shake a new developer cartridge a few times as shown.
  - Shake it horizontally as shown with the arrow.

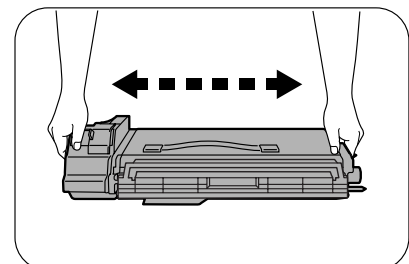

- 6) Remove the pawls (3 positions) of the protective cover at their side.

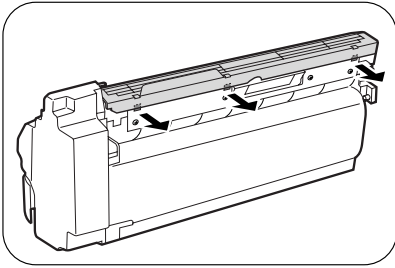

- 7) Remove the protective cover.

- Pull the cover in the arrow direction to remove.

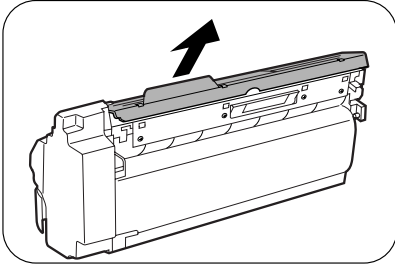

- 8) Insert the developer cartridge.

- Gently insert the developer cartridge along the guide until it locks.

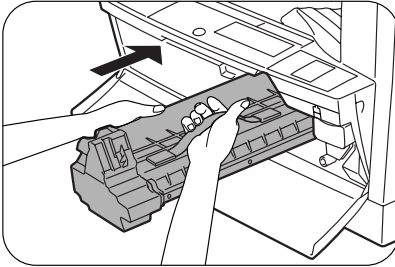

- 9) Fix the developer cartridge with the fixing screw which is packed together with the machine.

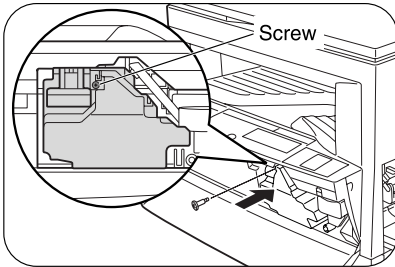

- 10) Close the front cover A, then close the side cover B.

- When closing the front cover, gently press the both sides.
- When closing the side cover, hold the knob.
- When closing the covers, be sure to close the front cover first, then close the side cover. If closed in a wrong sequence, the covers may be broken.

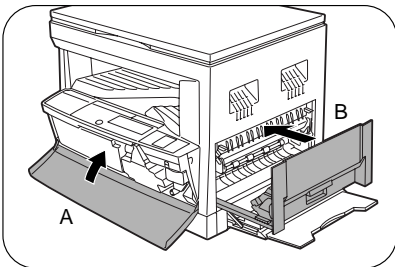

#### 4. Removal and storage of fixing screw

- 1) Lift the knob and gently pull out the tray.

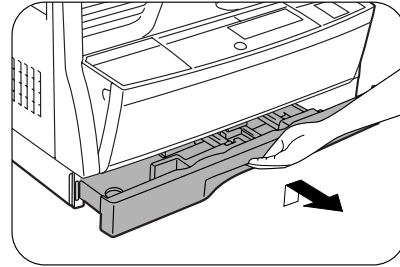

- 2) Hold the paper pressure plate and turn the fixing screw in the arrow direction.

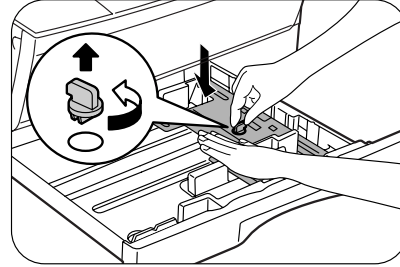

- 3) Store the fixing pin and the fixing screw in the tray.

- Store the fixing screw which was removed in the above procedure 2 and the fixing screw which was removed in procedure 2 of 2.
- Removal of protective material and fixing screw in the storage place in the tray.

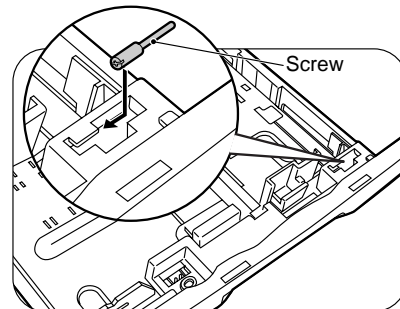
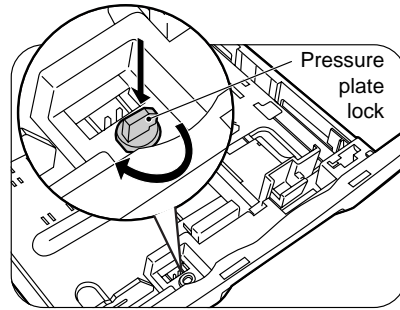

## 5. Changing the copy paper size in the tray

- 1) Gently lift and pull out the paper tray until it stops.
- 2) Push the pressure plate down until it locks in place.
- 3) Squeeze the lock lever of the front guide and slide the front guide to match the width of the paper.

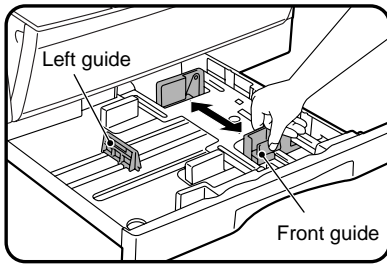

- 4) Move the left guide to the appropriate slot as marked on the tray.
  - When using 11" x 17" copy paper, store the left guide in the slot at the left front of the paper tray.

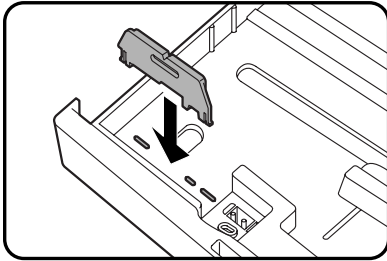

- 5) Load copy paper into the tray.
- 6) Place the paper size plate in the front of the paper tray.
  - The paper size indication which shows through the slot on the front of the copier should match the selected paper size.
- 7) Push the paper tray firmly back into the copier.
- 8) To set the selected paper size, press and hold down the PAPER SIZE ENTER key. The selected paper feed location indicator and the corresponding paper size (which has been set) indicator will blink. All other indicators will go out.
  - For paper size setting, ensure that the COPY mode has been selected. However, if printer or facsimile output is being performed, paper size setting cannot be made even in the COPY mode.

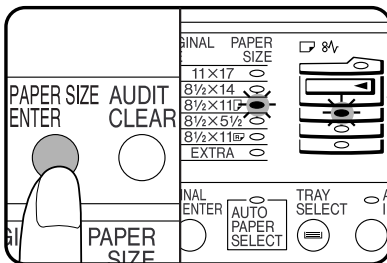

- 9) Use the TRAY SELECT key to select the paper tray of which the paper size has been changed.
  - Each time the TRAY SELECT key is pressed, a paper tray is indicated with a blinking paper feed location indicator. If an optional paper feed unit is not installed, this operation is not needed.

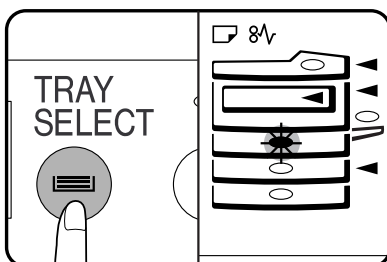

- 10) Use the ORIGINAL SIZE ENTER key to select the paper size which is set.

- Each time the ORIGINAL SIZE ENTER key is pressed, a paper size will be indicated with a blinking paper size indicator.

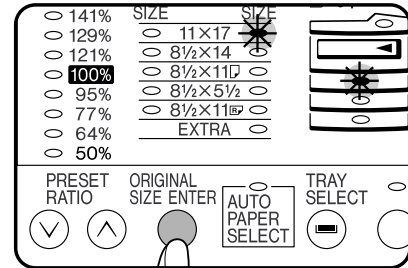

- 11) Press the START key and then the PAPER SIZE ENTER key.
  - To change the paper size setting of another tray, repeat steps 9 to 10 after pressing the START key.

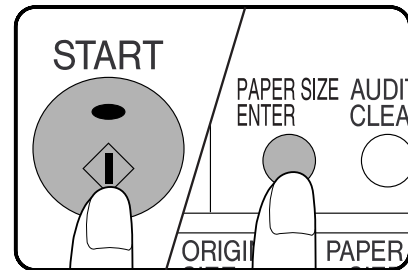

## [6] OPERATIONAL DESCRIPTIONS

### 1. Outline of operation

The outline of operation is described referring to the basic configuration.

#### (Basic configuration)

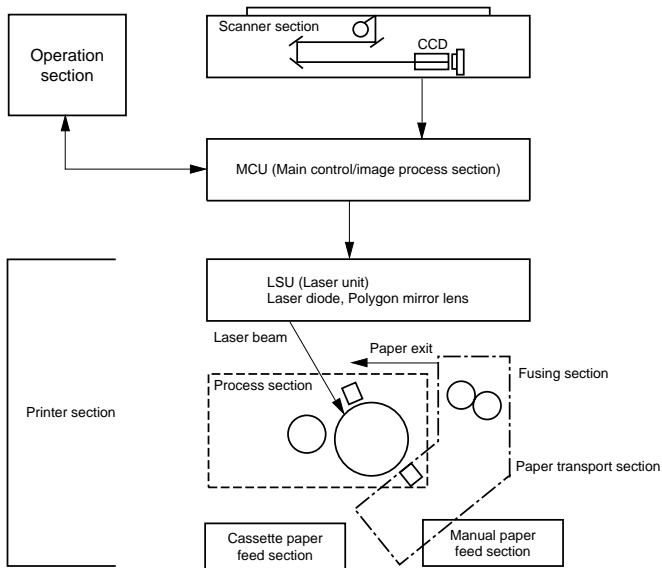

### Outline of copy operation

#### A. Setting conditions: Operation panel

- Set copy conditions such as the copy quantity and the copy density with the operation section, and press the START key. The information on copy conditions is sent to the MCU.

#### B. Image scanning: Scanner section

- When the START key is pressed, the scanner section starts scanning of images. The light from the copy lamp is reflected by the document and passed through the lens to the CCD.

#### C. Photo signal/Electric signal conversion: Scanner section

- The image is converted into electrical signals by the CCD circuit and passed to the MCU.

#### D. Image process: MCU

- The document image signal sent from the CCD circuit is processed under the revised conditions and sent to the LSU (laser unit) as print data.

#### E. Electric signal/Photo signal (laser beam) conversion: LSU

- The LSU emits laser beams according to the print data. (Electrical signals are converted into photo signals.)
- The laser beams are radiated through the polygon mirror and various lenses to the OPC drum.

#### F. Printing: Process section

- Electrostatic latent images are formed on the OPC drum according to the laser beams, and the latent images are developed to be visible images (toner images).
- Meanwhile the paper is fed to the image transfer section in synchronization with the image lead edge.
- The toner image is transferred on the paper.

#### G. Fusing: Fusing section

- Heat and a pressure are applied to the toner image on the copy paper to fuse the image on the paper.

### 2. Scanner section

#### A. Scan process

The scanner has sensors that are arranged in a line. These sensors scan a certain area of a document at a time and deliver outputs sequentially. When the line is finished, the next line is scanned, and this procedure is repeated. The figure below shows the case where an image which is scanned is shown with solid lines.

The direction of this line is called main scanning direction, and the scanning direction sub scanning direction. In the figure above, one line is divided into 5 sections. Actually, however, one line is divided into thousands of sections. For scanning, the light receiving element called CCD is used.

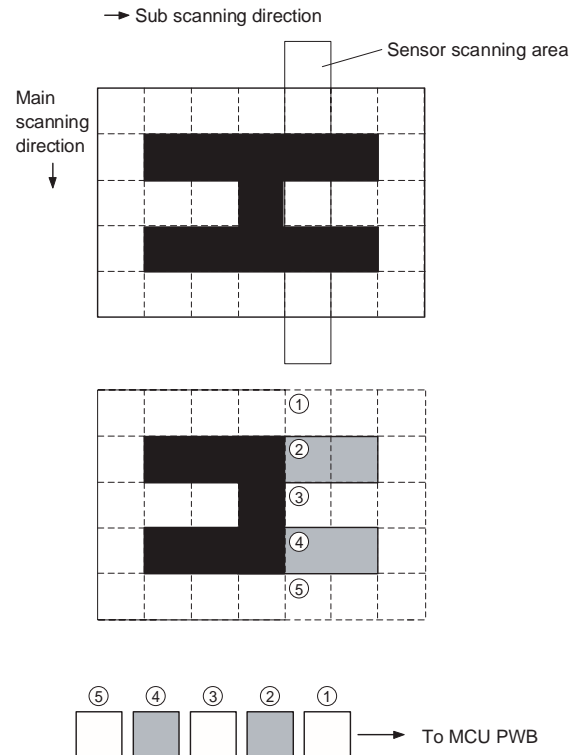

The basic resolution indicates the scanner capacity. The basic resolution is expressed in dpi (dot/inch) which shows the number of light emitting elements per inch on the document.

The basic resolution of this machine is 400dpi.

In the sub scanning direction, at the same time, the motor that drives the optical system is controlled to scan the image at the basic resolution.

## B. Basic structure of scanner section

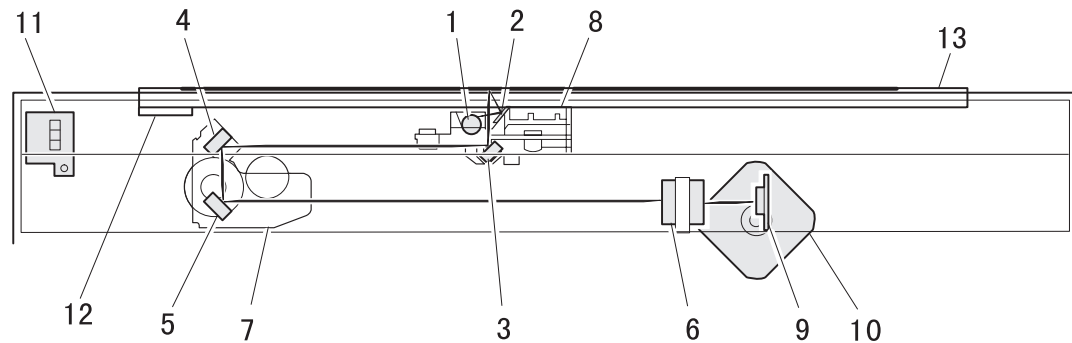

1	Copy lamp (Xenon lamp)	Generate photo energy to scan documents.
2	Reflector (Converging plate)	Collects light emitted from the copy lamp and radiate the document.
3	No. 1 mirror	Refracts the reflection light from the document to No. 2 mirror.
4	No. 2 mirror	Refracts the reflection light from No. 1 mirror.
5	No. 3 mirror	Refracts the reflection light from No. 2 mirror.
6	Lens	Converges reflected light from the document to form images on the CCD element.
7	No. 2/3 mirror unit	Includes No. 2/3 mirror. Driven in synchronization with the copy lamp unit.
8	Copy lamp unit	Includes the copy lamp, the reflector, and No. 1 mirror. Driven in synchronization with No. 2/3 mirror unit by the mirror motor.
9	CCD PWB	Reflected light (image) formed on the CCD is converted into electrical signals (analog signals) then into digital signals and sent to the MCU.
10	Mirror motor	Drives the copy lamp unit and No. 2/3 mirror unit according to the scanning speed.
11	MHPS (Mirror home position sensor)	Detects the home position of No. 2/3 mirror unit.
12	Reference white plate	Reference white sheet for scanning documents. The reference line of magnification ratio adjustment during SIM is also drawn.
13	OC glass	Glass table to put a document on it.

The light from the light source (Xenon lamp) is reflected by a document and passed through three mirrors and reduction lenses to the CCD element (image sensor) where images are formed. This system is known as the reduction image sensor system. Photo energy on the CCD element is converted into electrical signals (analog signals). (Photo-electric conversion). The output signals (analog signals) are converted into digital signals (A/D conversion) and passed to the MCU (main control/image process section). The resolution at that time is 400dpi. The mirror unit in the scanner section is driven by the mirror motor. The MHPS is provided to detect the home position of the copy lamp unit.

## 3. Process section

### A. Basic structure

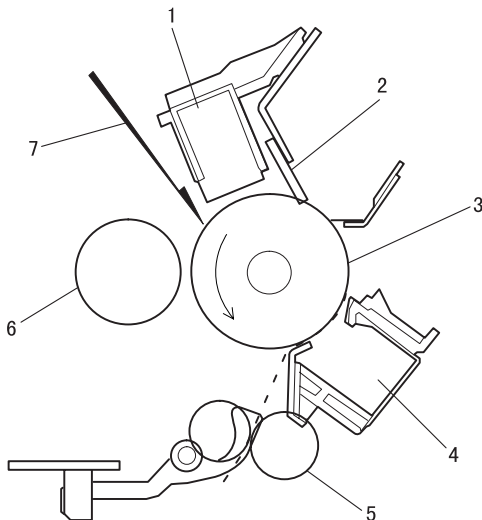

1	Main charger unit	Charges the OPC drum.
2	Cleaning blade	Collects waste toner on the OPC drum.
3	OPC drum	Images are formed by laser beams electrically, and toner is attached to the image.
4	Transfer unit	Toner on the OPC drum is transferred to the print paper by the potential difference.
5	Resist roller	Makes synchronization between the paper and the print image.
6	MG roller	Magnetic brush is formed by developer to put toner on the OPC drum.
7	(Laser beam)	Forms images on the OPC drum.

**Operation cycle**

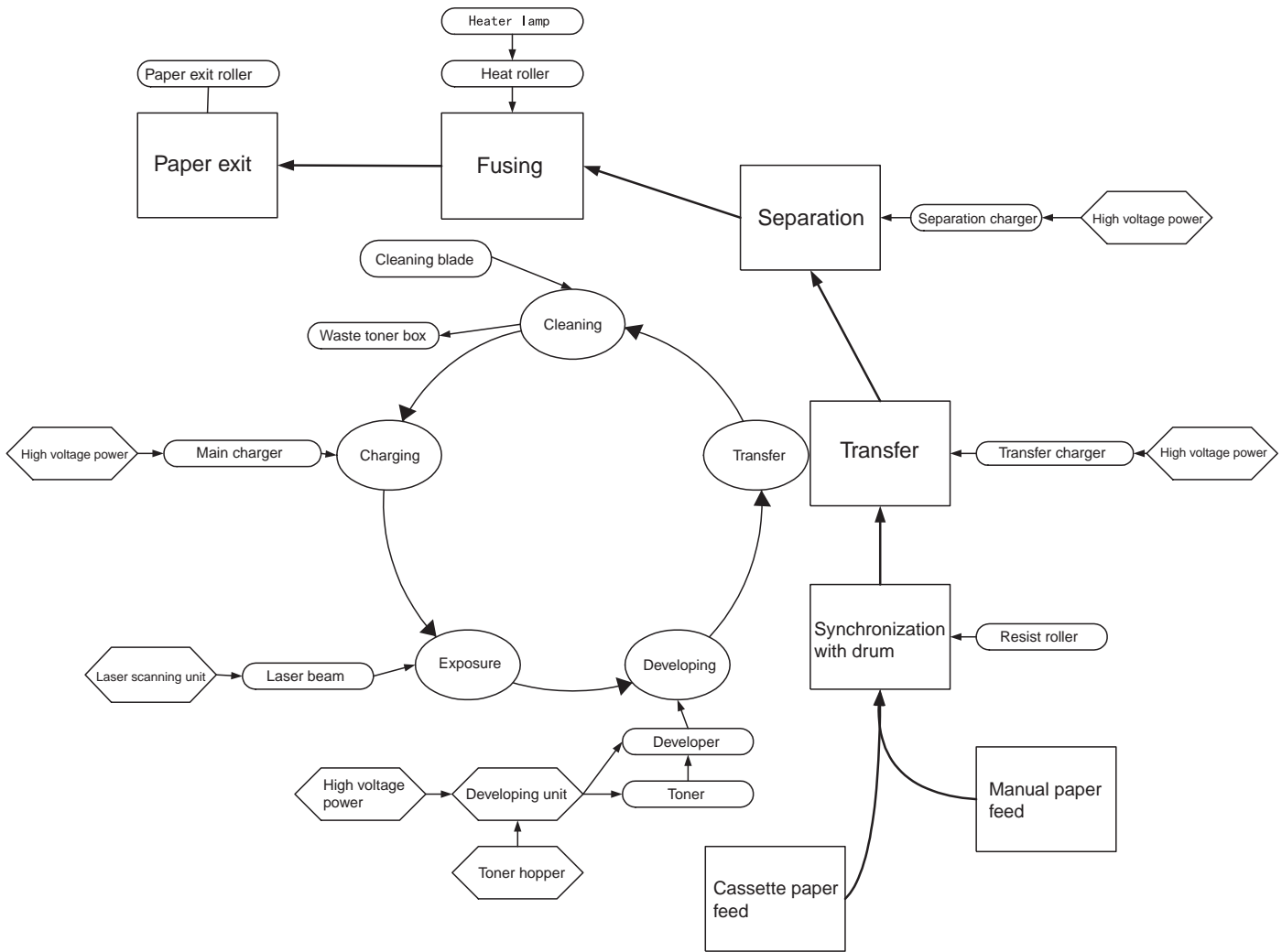

**B. Outline of print process**

The printer section of this machine employs the laser print system where print images are formed by the laser beams on the OPC drum. A high voltage (corona) is applied from the main charger to the OPC drum to charge the OPC drum.

Laser beams are radiated to the charged OPC drum to form electrical images on the OPC drum. (Exposure)

(At that time, the print image on the OPC drum cannot be seen: latent electrostatic image)

By the potential difference between the unexposed area and the latent electrostatic images, toner is attracted only to the images. (Developing)

(At that time, the print image formed by toner on the OPC drum can be seen. Visible images)

The toner image on the OPC drum is transferred on the print paper by the transfer corona (voltage).

After that, the print paper with the toner image on it is subject to heat and pressure in the fusing section to fuse the image on the paper.

This machine employs the following organic photoconductor (OPC) drum.

An OPC drum is used for the photoconductor.  
(Structure of the OPC drum layers)



**C. Actual print process**

**(1) Charging**

A high voltage is applied to the main charger, and negative charges are discharged to the OPC drum. A screen grid is provided between the main charger and the OPC drum, and negative charges are uniformly charged on the OPC drum surface.

Positive charges are attracted by the negative electrode on the OPC drum surface and excited in the aluminum layer in the OPC drum.

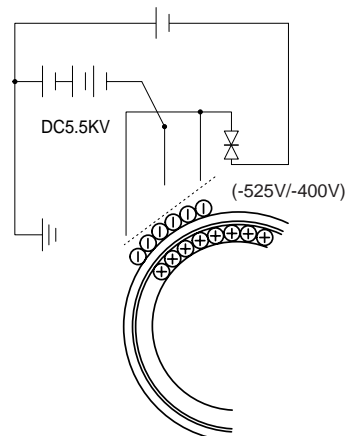



**(2) Exposure**

A Laser beam is generated from the semiconductor laser and controlled by the print pattern signal. The laser writes onto the OPC drum surface through the polygon mirrors and lens. The resistance of the OPC layer decreases for an area exposed by the laser beam (corresponding to the print pattern signal). The beam neutralizes the negative charge. An electrostatic latent image is formed on the drum surface.

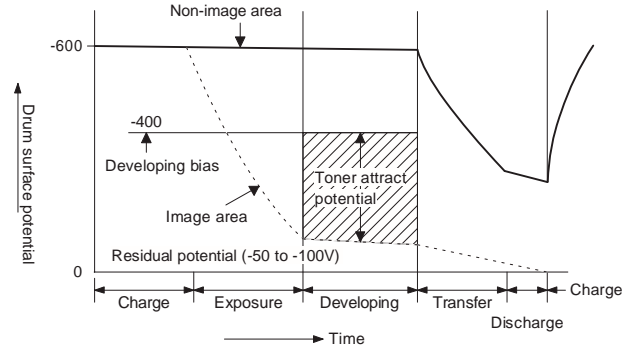
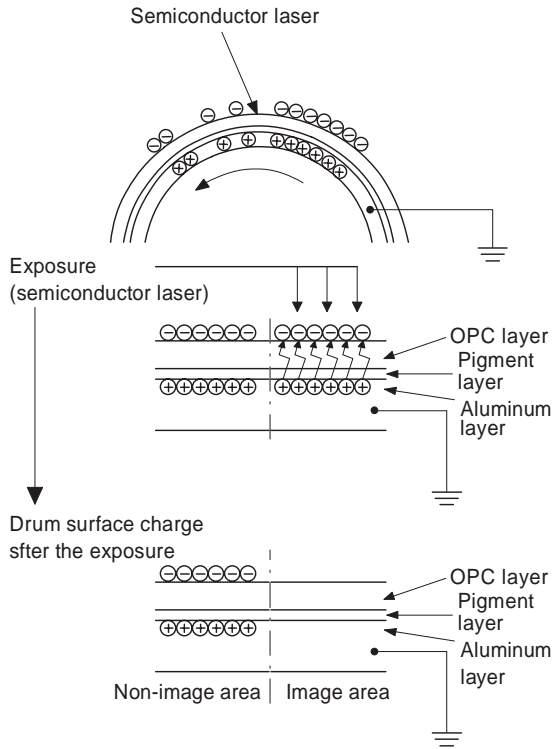

Toner is attracted over the shadowed area because of the developing bias.

**(4) Transfer**

The visible image on the drum surface is transferred onto the print paper by applying a positive charge from the transfer corona to the backside of the print paper.

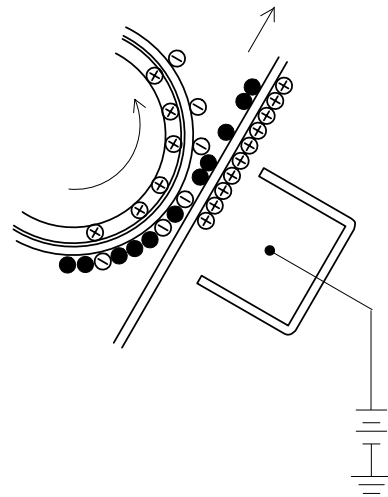

**(3) Developing (DC bias)**

A bias potential is applied to the MG roller in the two component magnetic brush developing method, and the toner is charged negative through friction with the carrier. Non-image area of the drum surface charged with negative potential repel the toner, whereas the laser exposed portions where no negative charges exist, attract the toner. As a result, a visible image appears on the drum surface.

- ⊕ : Carrier (Magnetized particle)
- : Toner (Charge negative by friction)
- (N) (S) : Pemanent magnet (provided in three locations)

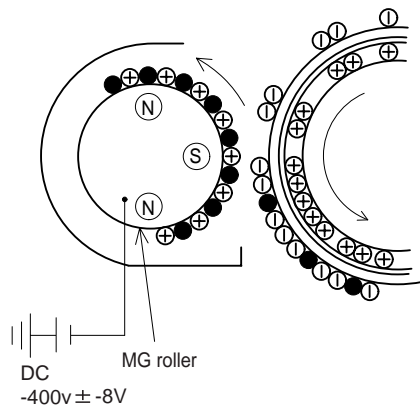

**(5) Separation**

Since the print paper is charged positively by the transfer corona, it is discharged by the separation corona. The separation corona is connected to ground.

**(6) Cleaning**

Toner remaining on the drum is removed and collected by the cleaning blade. It is transported to the waste toner collecting section in the cleaning unit by the waste toner transport roller.

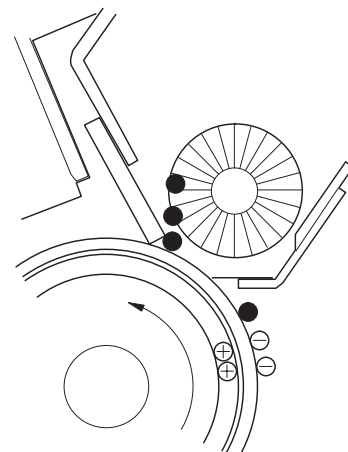

## (7) Optical discharge (Semiconductor laser)

Before the drum rotation is stopped, the semiconductor laser is radiated onto the drum to reduce the electrical resistance in the OPC layer and eliminate residual charge, providing a uniform state to the drum surface for the next page to be printed.

When the electrical resistance is reduced, positive charges on the aluminum layer are moved and neutralized with negative charges on the OPC layer.

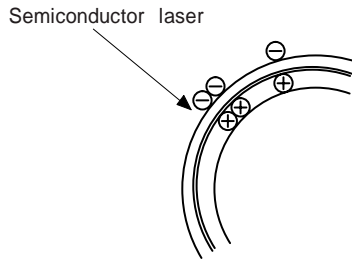

### a. Charge by the Scorotron charger

#### <1> Function

The Scorotron charger functions to maintain the surface potential of the drum even at all times which. It is used to control the surface potential regardless of the charge characteristics of the photoconductor.

#### <2> Basic function

A screen grid is placed between the saw tooth and the photoconductor. A stable voltage is added to the screen grid to maintain the corona current on the photoconductor. As the photoconductor is charged by the saw tooth from the main corona unit, the surface potential increases. This increases the current flowing through the screen grid. When the photoconductor potential nears the grid potential, the current turns to flow to the grid so that the photoconductor potential can be maintained at a stable level.

### b. Process controlling

#### <1> Function

The print pattern signal is converted into an invisible image by the semiconductor laser using negative to positive (reversible) developing method. Therefore, if the developing bias is added before the drum is charged, toner is attracted onto the drum. If the developing bias is not added when the drum is charged, the carrier is attracted to the drum because of the strong electrostatic force of the drum.

To avoid this, the process is controlled by adjusting the drum potential and the grid potential of the Scorotron charger.

#### <2> Basic function

Voltage added to the screen grid can be selected, high and low. To make it easily understood, the figure below shows voltage transition at the developer unit.

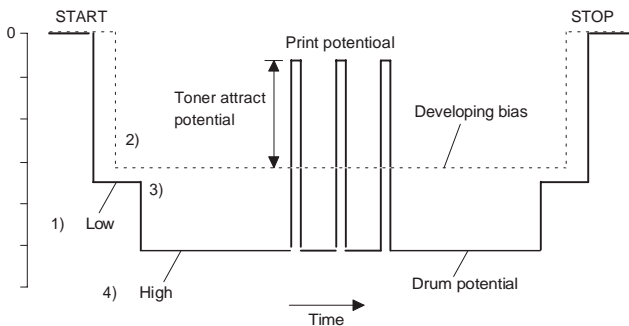

#### <3> Start

- 1) Because the grid potential is at a low level, the drum potential is at about  $-400V$ . (Carrier may not be attracted though the carrier is pulled towards the drum by the electrostatic force of  $-400V$ .)
- 2) Developing bias ( $-400V$ ) is applied when the photoconductor potential is switched from LOW to HIGH.
- 3) Once developing bias ( $-400V$ ) is applied and the photoconductor potential rises to HIGH, toner will not be attracted to the drum.

#### <4> Stop

The reverse sequence takes place.

### c. Retaining developing bias at an abnormal occurrence

#### <1> Function

The developing bias will be lost if the power supply was removed during print process. In this event, the drum potential slightly abates and the carrier makes deposits on the drum because of strong static power. To prevent this, the machine incorporates a function to retain the developing bias for a certain period and decrease the voltage gradually against possible power loss.

#### <2> Basic function

Normally, the developing bias voltage is retained for a certain time before the drum comes to a complete stop if the machine should stop before completing the normal print cycle. The developing bias can be added before resuming the operation after an abnormal interruption. Therefore, carrier will not make a deposit on the drum surface.

## 4. Laser unit

The image data sent from the MCU (image process circuit) is sent to the LSU (laser unit), where it is converted into laser beams.

### A. Basic structure

The LSU unit is the writing section of the digital optical system.

The semiconductor laser is used as the light source, and images are formed on the OPC drum by the polygon mirror and  $f\theta$  lens, etc.

The laser beams are passed through the collimator lens, the cylindrical lens, the polygon mirror, the  $f\theta$  lens, and the mirror to form images on the OPC drum in the main scanning direction. The laser emitting PWB is provided with the APC (auto power control) in order to eliminate fluctuations in the laser power. The BD PWB works for measurement of the laser writing start point.

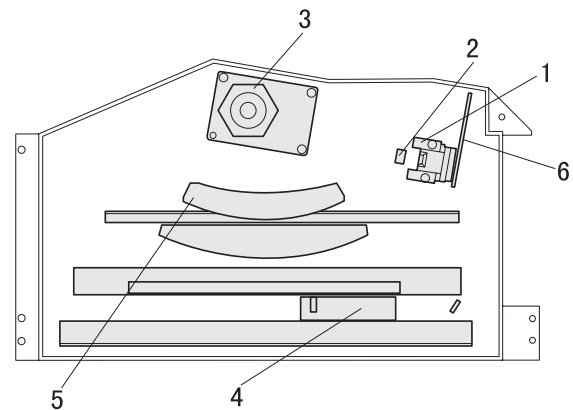

1	Semiconductor laser	Generates laser beams
2	Collimator lens	Converges laser beams in parallel
3	Polygon mirror, polygon motor	Reflects laser beams at a constant rpm
4	BD (Mirror, lens, PWB)	Detects start timing of laser scanning
5	$f\theta$ lens	Converges laser beams at a spot on the drum. Makes the laser scanning speeds at both ends of the drum same as each other. (Refer to the figure below.)
6	Laser emitting PWB	Emits laser beams according to the image data.



Makes the laser scanning speeds at both ends of the drum same as each other.

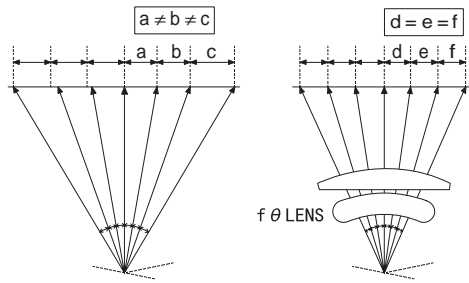

## B. Laser beam path

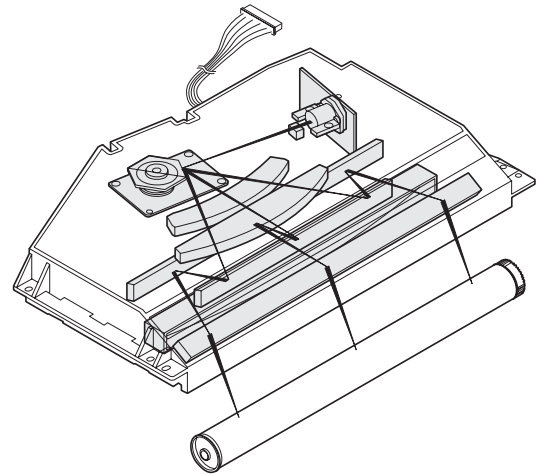

## 5. Paper feed section

### A. Basic structure

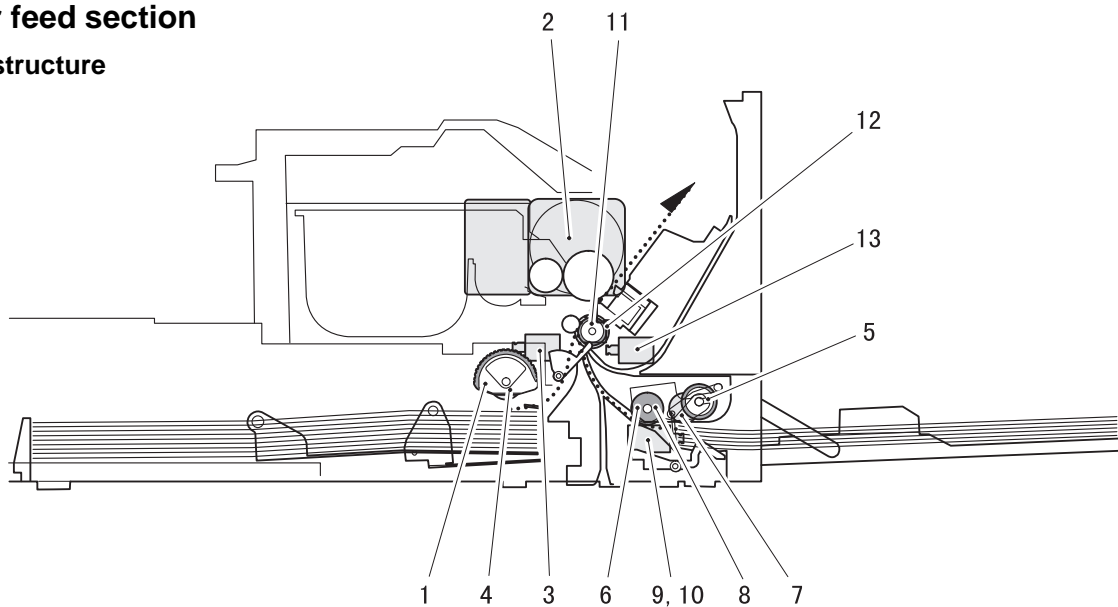

1	No. 1 cassette paper feed roller (Semi-circular roller)	Picks up paper from No. 1 cassette.
2	Main motor	Drives the process section and the paper transport section.
3	No. 1 cassette paper feed solenoid	Rotates and controls No. 1 cassette paper feed roller.
4	No. 1 cassette paper feed roller clutch	Drives No. 1 cassette paper feed roller.
5	Manual paper feed roller	Picks up paper from the manual paper feed tray.
6	Manual paper transport roller	Transport paper which was picked up from the manual paper feed tray.
7	Manual paper feed roller clutch	Drives the manual paper feed roller.
8	Manual paper transport roller clutch	Drives the manual paper transport roller.
9	Manual paper feed roller solenoid	Rotates and controls the manual paper feed roller.
10	Manual paper transport roller solenoid	Rotates and controls the manual paper transport roller.
11	Resist roller	Takes synchronization between the paper lead edge and the image lead edge.
12	Resist roller clutch	Drives the resist roller.
13	Resist roller solenoid	Rotates and controls the resist roller.

### B. Brief descriptions of operations

This machine allows two ways of paper feed system: cassette paper feed and manual paper feed.

The cassette of universal type is employed to hold 250 sheets. The front loading system allows to attach or detach the cassette from the front of the machine.

Paper size can be selected by the user.

Paper size detection is set by the software. (User setting is allowed.)

By installing the optional 1-step paper feed unit or the multi-step paper feed unit, the capacity of paper can be increased.

#### (1) Cassette paper feed operation

Select the cassette and press the START button, and the paper feed roller solenoid will be turned on and the paper feed clutch will be released.

The drive power of the main motor is transmitted through the paper feed roller clutch to the paper feed roller, rotating the paper feed roller and feeding paper.

## (2) Manual paper feed tray operation

Select the manual paper feed tray and press the START button, and the manual paper feed roller will be turned on to bring the paper feed roller in contact with paper and lift the shutter simultaneously.

The drive power of the main motor is transmitted through the manual paper feed roller clutch to the manual paper feed roller, rotating the manual paper feed roller and feeding paper.

## (3) Resist roller

In order to make synchronization between the paper lead edge fed from the paper feed port and the image lead edge, the roller is kept stationary for a certain time after the paper reaches at the roller to warp the paper a little.

When the paper is warped to a certain level, the resist roller solenoid is turned on to release the resist roller clutch.

The drive power of the main motor is transmitted through the resist roller clutch to the resist roller, rotating the resist roller and feeding paper.

## 6. Fusing section

### A. Basic composition

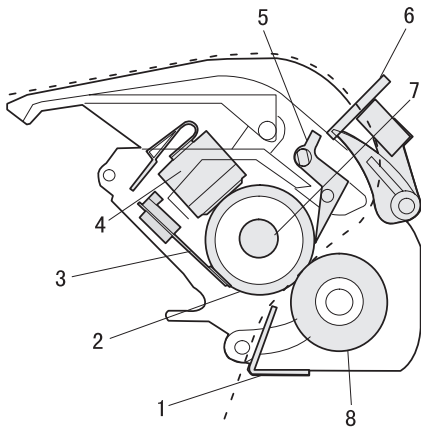

### (Top view)

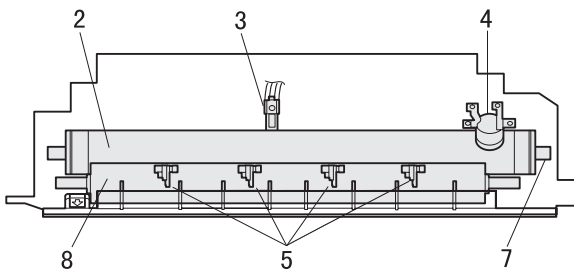

1	Before-fusing paper guide	Guides the paper transported from the process section to the fusing unit.
2	Upper heat roller	Applies heat and pressure to the paper to fuse.
3	Thermistor	Detects the surface temperature of the upper heat roller.
4	Thermostat	Stops power supply to the heat roller in case of an abnormally high temperature of the heat roller.
5	Separation pawl	Separates the print paper from the upper heat roller.
6	POD1	Detects that the paper has been transported from the fusing section.
7	Heater lamp	Heats the heat roller.
8	Lower heat roller	Applies a pressure to the paper together with the upper heat roller.

## B. Heat roller

A pressure roller is used for the heat roller and a silicone rubber roller is used for the lower heat roller for better toner fusing performance and paper separation.

## C. Separator pawl

Four separator pawls are used on the upper heat roller. The separator pawls are teflon coated to reduce friction with the roller and prevent a smear on the paper caused by the separator pawl.

## D. Thermal control

- 1) The heater lamp, thermistor, main PWB, DC power supply PWB, and triac within the power supply unit are used to control the temperature in the fuser unit. To prevent against abnormally high temperature in the fuser unit, a thermostat is used for safety purposes.

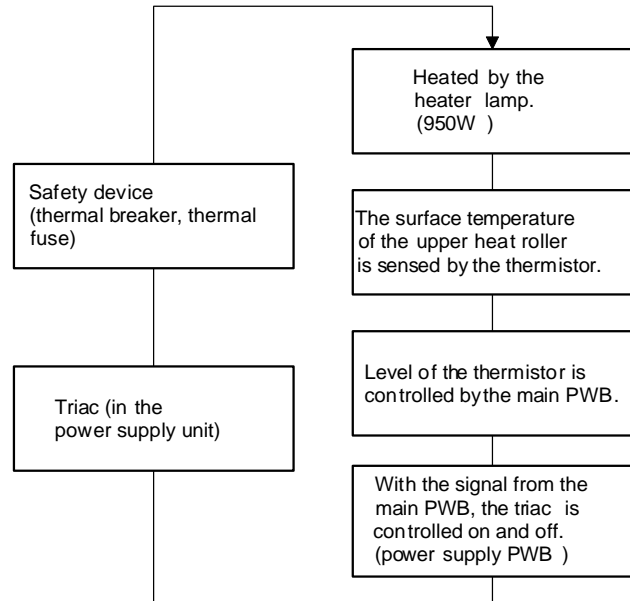

- 2) The surface temperature of the upper heat roller is set to 180°C ~ 195°C. The surface temperature during the power save mode is set to 100°C.
- 3) The self-check function comes active when one of the following malfunctions occurs, and an "H" is displayed on the copy quantity display.

Fusing temperature error value

H4 (Low temperature error)

- During machine operation

The case where the fusing temperature (thermistor output value) does not reach 155°C within 55 sec from lighting of the heater lamp. (If the toner motor rotates for 10 sec or more continuously when starting the machine, the case where the fusing temperature does not reach 155°C within 60 sec.)

- During printing

When the fusing temperature (thermistor output value) falls below 145°C.

H3 (High temperature error)

Fusing temperature (thermistor output value) of about 220 to 240°C (varies depending on the resistance.)

## E. Fusing resistor

### (1) Fusing resistor

Since the upper heat roller is conductive when copy paper is highly moistured and the distance between the transfer unit and the fusing unit is short, the transfer current leaks through the copy paper, the upper heat roller and the discharging brush.

To prevent against this, a resistor of 150MΩ is provided between the frame and the discharge brush to minimize leak current and improve transfer efficiency.

## [7] ADJUSTMENTS

### 1. Adjustment item list

Section		Adjustment item		Adjustment procedure/SIM No.	
A	Process section	(1)	Developing doctor gap adjustment	Developing doctor gap adjustment	
		(2)	MG roller main pole position adjustment	MG roller main pole position adjustment	
		(3)	Developing bias voltage output adjustment	SIM 8-1	
		(4)	Main charger voltage output adjustment	SIM 8-2/SIM 8-3	
		(5)	Transfer charger current adjustment	SIM 8-6	
B	Mechanism section	(1)	Image position adjustment	SIM 50-1/SIM 50-10	
		(2)	Main scanning direction (FR direction) distortion balance adjustment	No. 2/3 mirror base unit installing position adjustment	
				Copy lamp unit installing position adjustment	
		(3)	Main scanning direction (FR direction) distortion adjustment	F rail height adjustment	
		(4)	Sub scanning direction (scanning direction) distortion adjustment	Winding pulley position adjustment	
		(5)	Main scanning direction (FR direction) magnification ratio adjustment	SIM 48-1	
		(6)	Sub scanning direction (scanning direction) magnification ratio adjustment	a	OC mode in copying (SIM 48-2)
				b	SPF mode in copying (SIM 48-5)
				c	OC mode in FAX (SIM 48-6)
d	SPF mode in FAX (SIM 48-7)				
(7)	Off center adjustment	a	OC mode (SIM 50-13)		
		b	SPF mode (SIM 50-16)		
(8)	Document size detection sensor	SIM 41-2			
C	Image density adjustment	(1)	Copy mode	SIM 46-1	

### 2. Copier adjustment

#### A. Process section

##### (1) Developing doctor gap adjustment

- Loosen the developing doctor fixing screw A.
- Insert a thickness gauge of 1.5mm to the three positions at 20mm and 130mm from the both ends of the developing doctor as shown.

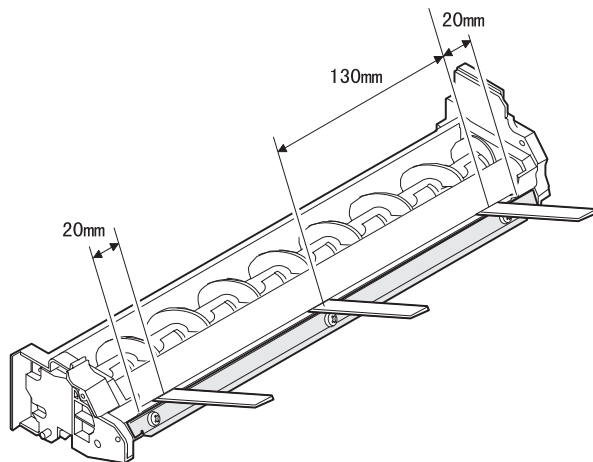

- Push the developing doctor in the arrow direction, and tighten the developing doctor fixing screw. (Perform the same procedure for the front and the rear frames.)
  - Check the clearance of the developing doctor. If it is within the specified range, then fix the doctor fixing screw with screw lock.
- \* When inserting a thickness gauge, be careful not to scratch the developing doctor and the MG roller.

##### <Adjustment specification>

Developing doctor gap

Both ends (20mm from the both ends):  $1.5 \pm 0.1$ mm

C (Center)(150mm from the both ends):  $1.5 \pm 0.1$ mm

##### (2) MG roller main pole position adjustment

- Remove and separate the waste toner box and put the developing unit on a flat surface.
- Tie a string to a needle or a pin.
- Hold the string and bring the needle close to the MG roller horizontally. (Do not use paper clip, which is too heavy to make a correct adjustment.) (Put the developing unit horizontally for this adjustment.)
- Do not bring the needle into contact with the MG roller, but bring it to a position 2 or 3mm apart from the MG roller. Mark the point on the MG roller which is on the extension line from the needle tip.

- 5) Measure the distance from the marking position to the top of the doctor plate of the developing unit to insure that it is 18mm. If the distance is not within the specified range, loosen the fixing screw A of the main pole adjustment plate, and move the adjustment plate in the arrow direction to adjust.

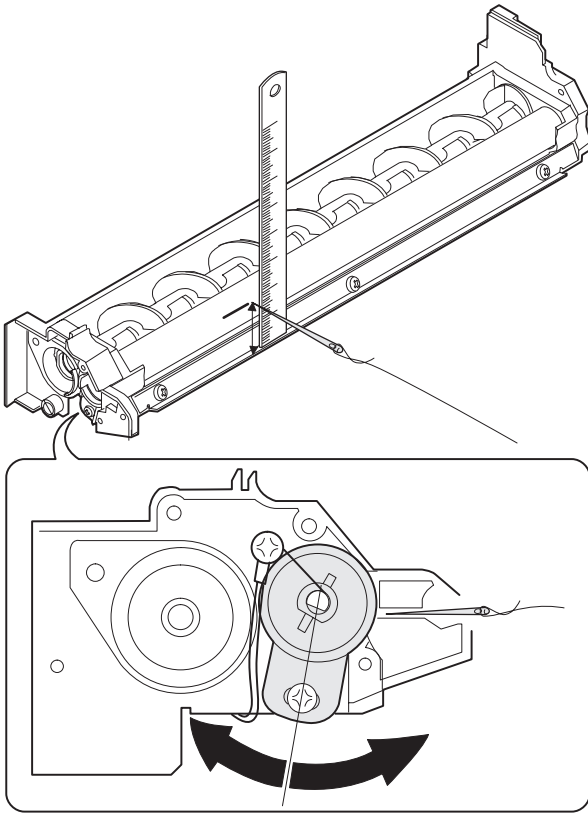

### (3) Developing bias voltage adjustment (SIM 8-1)

Note: • Use a digital multi-meter with an internal resistance of 10MΩ or more.

- 1) Set the digital multi-meter range to DC700V.
- 2) Put the test rod of the digital multi-meter on the developing bias voltage output check pin.
- 3) Execute SIM 8-1. (The developing bias voltage is outputted for 30 sec.)
- 4) Adjust the adjustment volume VR31 so that the output voltage is within the specified range shown below.

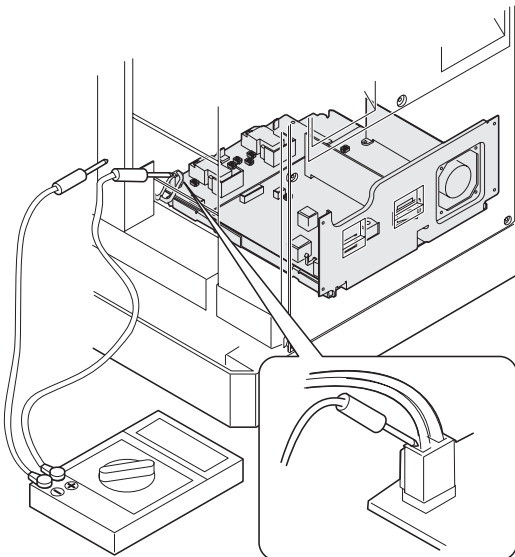

### <Adjustment specification>

Mode	Specification	SIM	
Developing bias voltage	DC-400±8V	SIM 8-1	VR31

### (4) Grid bias voltage adjustment (SIM 8-2, SIM 8-3)

Note: • Use a digital multi-meter with an internal resistance of 10MΩ or more.

- First adjust the grid LOW output, then adjust the grid HIGH voltage.

- 1) Set the digital multi-meter range to DC700V.
- 2) Put the test rod of the digital multi-meter on the grid bias voltage output check pin.
- 3) Execute SIM 8-3. (The grid bias voltage is outputted in the grid bias LOW output mode for 30 sec.)
- 4) Adjust the adjustment volume VR52 so that the output voltage is within the specified range shown below.
- 5) Execute SIM 8-2. (The grid bias voltage is outputted in the grid bias HIGH output mode for 30 sec.)
- 6) Adjust the adjustment volume VR51 so that the output voltage is within the specified range shown below.

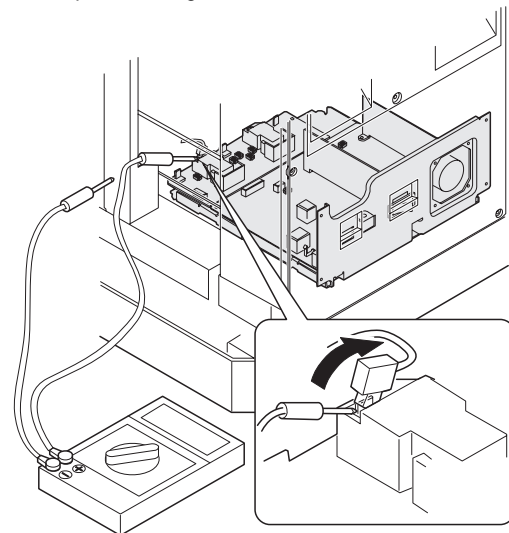

### <Adjustment specification>

Mode	Specification	SIM	
Grid bias LOW	DC-400±20V	SIM 8-3	VR52
Grid bias HIGH	DC-525±10V	SIM 8-2	VR51

## B. Mechanism section

### (1) Image position adjustment (SIM 50-1/SIM 50-10)

#### a. Image lead edge position adjustment

- 1) Set a scale on the document table as shown below.

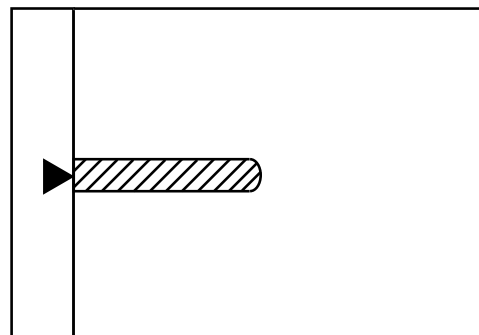

- 2) Make a copy.
- 3) Check the copy. If, necessary, perform the following adjustment procedure.
- 4) Execute SIM 50-1. Set AE (Laser radiation timing)/Lead edge void

value to 0. Make a copy (100%) again.

- 5) Set the laser radiation timing (image loss amount). Measure R in the figure below.

$$\text{Laser radiation timing} = R (\text{mm}) \times 10$$

- 6) Set the lead edge void.

Measure H in the figure below.

$$\text{Lead edge void} = H(\text{mm}) \times 10$$

- 7) Enter the set value and press the start key.

The correction value is stored and a copy is made.

(Example)

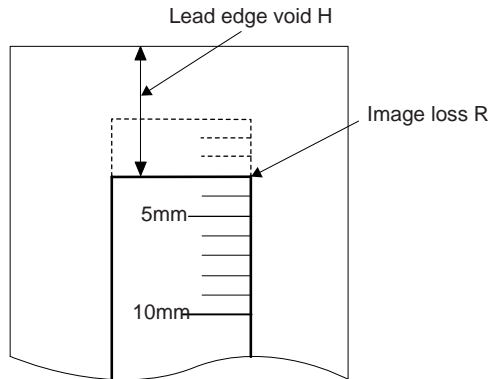

#### <Adjustment specification>

Mode	Specification	SIM	Set value	Set range
Laser radiation timing	1 ~ 4mm	SIM 45-1	1 step: 0.1mm shift	1 ~ 99
Lead edge void adjustment				

#### b. Rear edge void adjustment

- 1) Set a scale as shown in the figure below.

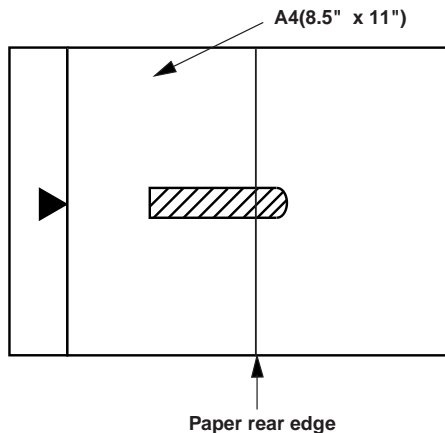

- 2) Set the document size to A4, and make two copies at 100%.  
3) Check the second copy. If necessary, perform the following adjustment procedure.

\* The first copy does not show the void. Be sure to check the second copy.

Void amount (Standard value: 0 ~ 4mm)

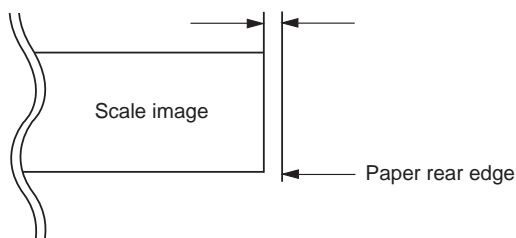

- 4) Execute SIM 50-1 and set the density mode to AE + TEXT + PHOTO (Rear edge void).

The currently set adjustment value is displayed.

- 5) Enter the set value and press the start key.

The correction value is stored and a copy is made.

#### <Adjustment specification>

Mode	Specification	SIM	Set value	Set range
Rear edge void	4mm or less	SIM 50-1	1 step: 0.1mm shift	1-99

#### c. Paper off center adjustment

- 1) Execute SIM 50-1 and set the density mode of Manual (TEXT) (Left edge void) to 0.

- 2) Set a test chart (UKOG-0089SCZZ) on the document table.

- 3) Select a paper feed port and make a copy.

Compare the copy and the test chart. If necessary, perform the following adjustment procedure.

- 4) Execute SIM 50-10.

After completion of warmup, shading is performed and the currently set off center adjustment value of each paper feed port is displayed.

- 5) Enter the set value and press the start key.

The correction value is stored and a copy is made.

#### <Adjustment specification>

Mode	Specification	SIM	Set value	Set range
Paper off center	Single: Center $\pm 2.0\text{mm}$	SIM 50-10	Add 1: 0.1mm shift to R side. Reduce 1: 0.1mm shift to L side.	1 ~ 99
	Duplex: Center $\pm 2.5\text{mm}$			

#### d. Left edge void area adjustment

Note: Before performing this adjustment, be sure to check that the paper off center adjustment (SIM 50-10) is completed.

- 1) Set a test chart (UKOG-0089SCZZ) on the document table.

- 2) Select a paper feed port and make two copies.

Compare the second copy and the test chart. If necessary, perform the following adjustment procedure.

\* The first copy does not show the void. Be sure to check the second copy.

- 3) Execute SIM 50-1 and set the density mode to Manual (TEXT) (Left edge void).

The currently set adjustment value is displayed.

(When the off center adjustment previously described is performed, "0" is displayed.)

- 4) Enter the set value and press the start key.

The correction value is stored and a copy is made.

#### <Adjustment specification>

Mode	Specification	SIM	Set value	Set range
Left edge void	1 ~ 4mm	SIM 50-1	1 step: 0.1mm shift	1 ~ 99

\* When the left edge void is set with the paper off center adjusted, the both edge void is automatically adjusted.

## (2) Main scanning direction (FR directional distortion balance adjustment)

1) Remove the OC glass and the right cabinet.

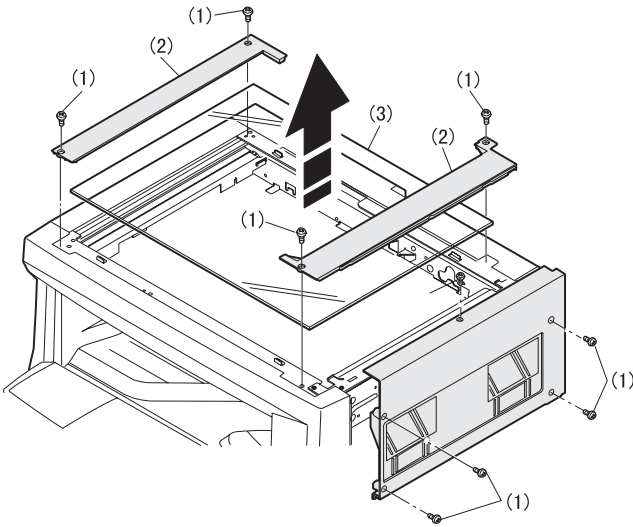

2) Loosen the copy lamp unit wire fixing screw.

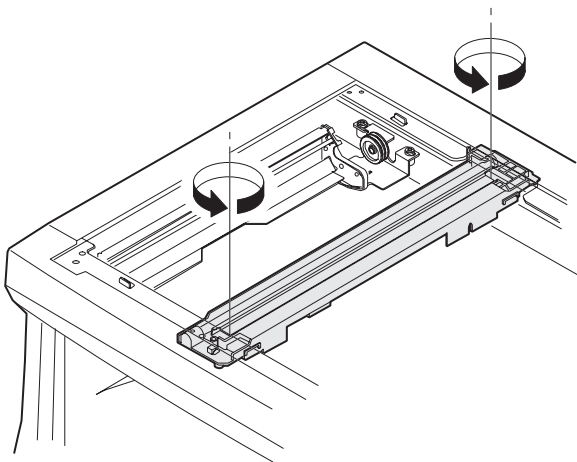
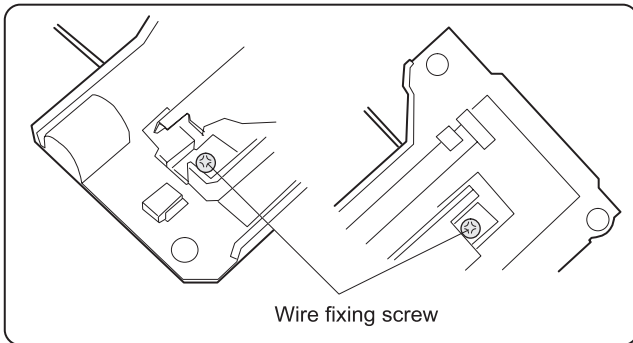

3) Manually turn the mirror base drive pulley and bring No. 2/3 mirror base unit into contact with the positioning plate.

At that time, if the front frame side and the rear frame side of No. 2/3 mirror base unit are brought into contact with the positioning plate at the same time, the mirror base unit parallelism is proper.

If one of them is in contact with the positioning plate, perform the adjustment of 4).

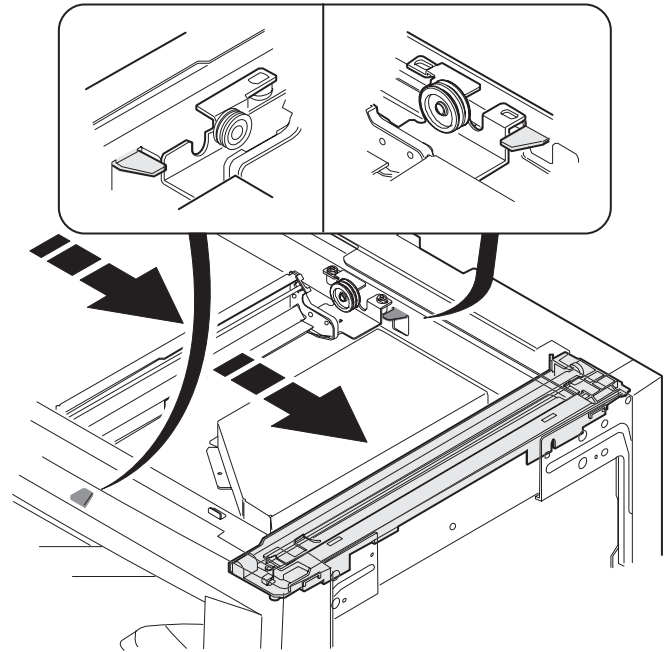

4) Loosen the set screw of the scanner drive pulley which is not in contact with No. 2/3 mirror base unit positioning plate.

5) Without moving the scanner drive pulley shaft, manually turn the scanner drive pulley until the positioning plate is brought into contact with No. 2/3 mirror base unit, then fix the scanner drive pulley.

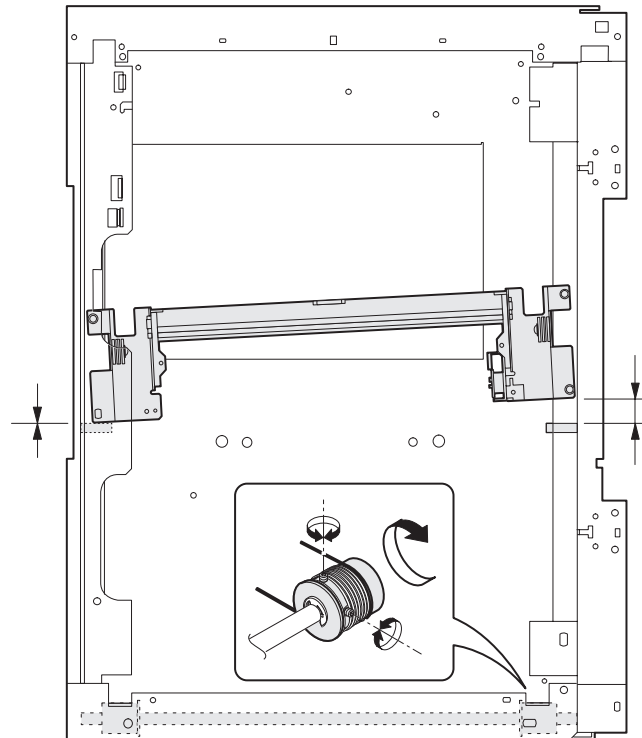



- 6) Put No. 2/3 mirror base unit on the positioning plate again, push the projections on the front frame side and the rear frame side of the copy lamp unit to the corner frame, and tighten the wire fixing screw.

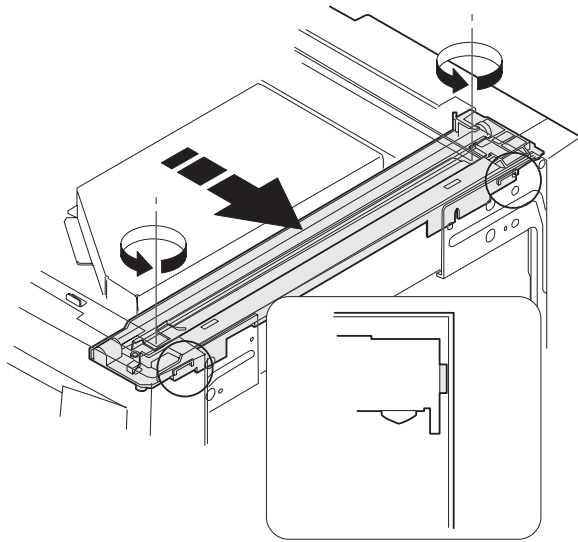
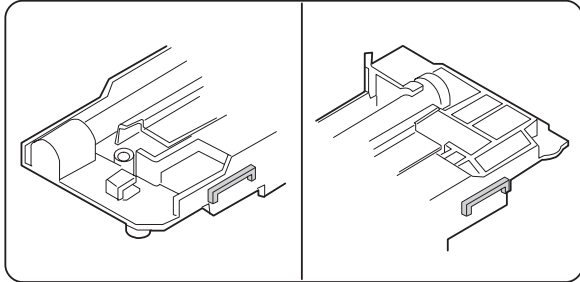

**(3) Main scanning direction (FR direction) distortion adjustment**

This adjustment must be performed in the following cases:

- When the mirror base drive wire is replaced.
- When the lamp unit, or No. 2/3 mirror holder is replaced.
- When a copy as shown is made.

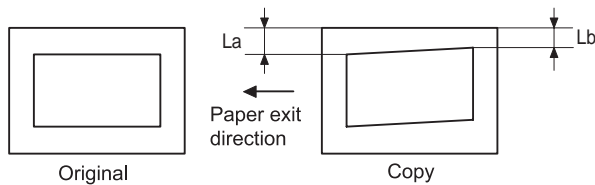

- 1) Set A3 (11" x 17") white paper on the original table as shown below.

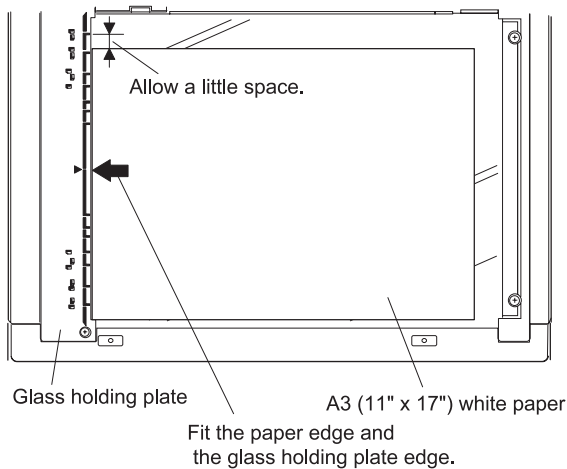

- 2) Open the original cover and make a normal (100%) copy.  
 3) Measure the width of the black background at the lead edge and at the rear edge.

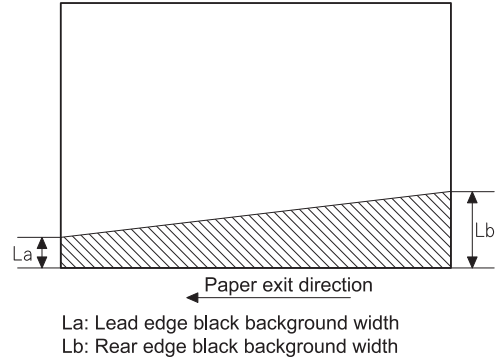

If the width (La) of the black background at the lead edge is equal that (Lb) at the rear edge, there is no need to execute the following procedures of 4) ~ 7).

- 4) Loosen the mirror base drive pulley fixing screw on the front frame side or on the rear frame side.

- When  $La < Lb$   
Turn the mirror base drive pulley on the rear frame side in the arrow direction B. (Do not move the mirror base drive pulley shaft.)
- When  $La > Lb$   
Turn the mirror base drive pulley on the front frame side in the arrow direction A. (Do not move the mirror base drive pulley shaft.)

- 5) Tighten the mirror base drive pulley fixing screw.

**<Adjustment specification>**

$La = Lb$

**(4) Sub scanning direction (scanning direction) distortion adjustment**

When there is no skew copy in the mirror base scanning direction and there is no horizontal error (right angle to the scanning direction), the adjustment can be made by adjusting the No. 2/3 mirror base unit rail height.

Before performing this adjustment, be sure to perform the horizontal image distortion adjustment in the laser scanner section.

This adjustment must be performed in the following cases:

- When the mirror base wire is replaced.
- When the copy lamp unit or No. 2/3 mirror unit is replaced.
- When the mirror unit rail is replaced or moved.
- When a following copy is made.

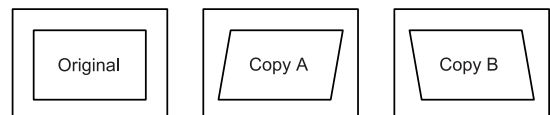

## 1) Making of a test sheet

Make test sheet by drawing parallel lines at 10mm from the both ends of A3 (11" x 17") white paper as shown below. (These lines must be correctly parallel to each other.)

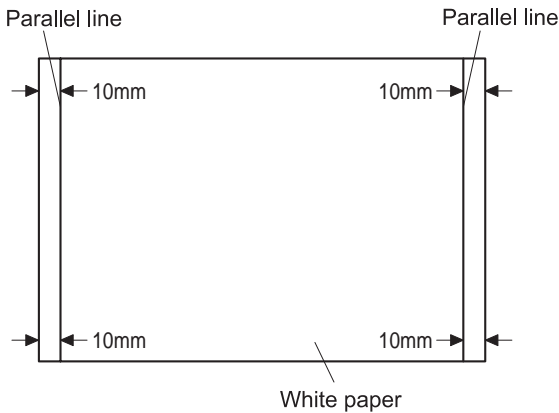

- 2) Make a normal (100%) copy of the test sheet on A3 (11" x 17") paper. (Fit the paper edge with the glass holding plate edge.)
- 3) Measure the distances ( $L_a$ ,  $L_b$ ,  $L_c$ ,  $L_d$ ) at the four corners as shown below.

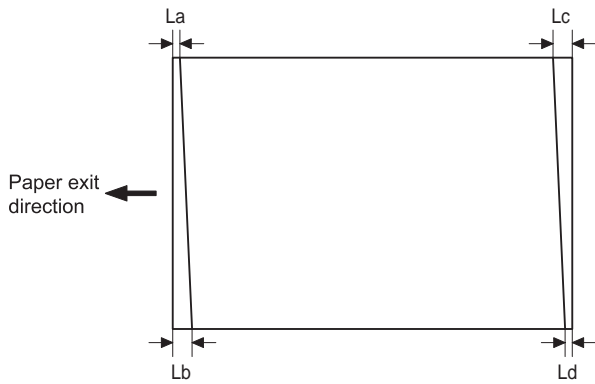

When  $L_a = L_b$  and  $L_c = L_d$ , no need to perform the procedures 4) and 5).

- 4) Move the mirror base B rail position up and down (in the arrow direction) to adjust.

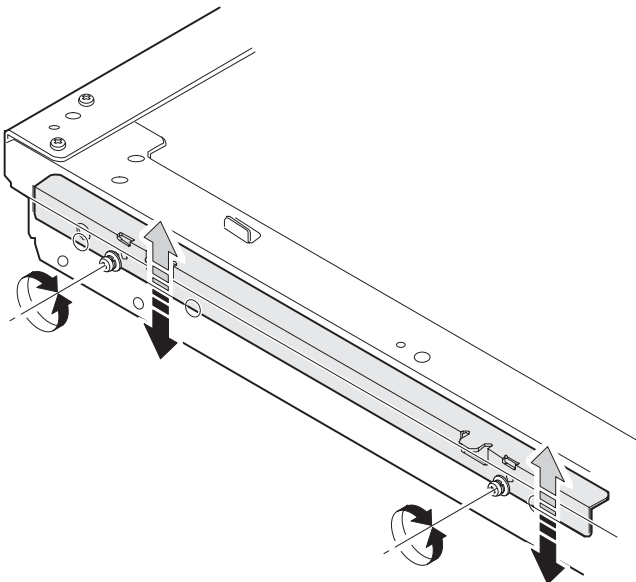

- When  $L_a > L_b$   
Shift the mirror base B rail upward by the half of the difference of  $L_a - L_b$ .
- When  $L_a < L_b$   
Shift the mirror base B rail downward by the half of the difference of  $L_b - L_a$ .  
Example: When  $L_a = 12\text{mm}$  and  $L_b = 9\text{mm}$ , shift the mirror base B rail upward by 1.5mm.
- When  $L_c > L_d$   
Shift the mirror base B rail downward by the half of the difference of  $L_c - L_d$ .
- When  $L_c < L_d$   
Shift the mirror base B rail downward by the half of the difference of  $L_d - L_c$ .
- \* When moving the mirror base rail, hold the mirror base rail with your hand.

## &lt;Adjustment specification&gt;

$L_a = L_b$ ,  $L_c = L_d$

- 5) After completion of adjustment, manually turn the mirror base drive pulley, scan the mirror base A and mirror base B fully, and check that the mirror bases are not in contact with each other.
- \* If the mirror base rail is moved extremely, the mirror base may be in contact with the frame or the original glass. Be careful to avoid this.

## (5) Main scanning direction (FR direction) magnification ratio adjustment (SIM 48-1)

Note: Before performing this adjustment, be sure to check that the CCD unit is properly installed.

- 1) Put a scale on the original table as shown below.

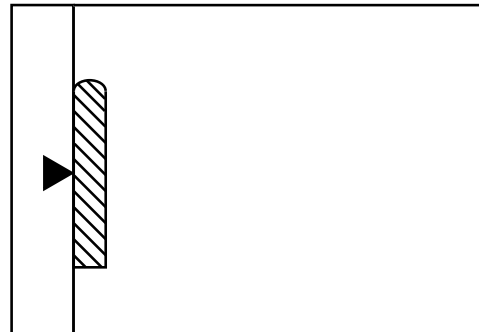

- 2) Execute SIM 48-1.
- 3) After warmup, shading is performed and the current set value of the main scanning direction magnification ratio is displayed on the display section in 2 digits.
- 4) Select the mode and press the start key again.
- 5) Auto correction mode (AE lamp ON)  
The mirror unit moves to the shading position, and the reference width of the reference white plate is scanned, and the correction value is automatically calculated from that scanned value.  
The correction value is displayed and a copy is made.
- 6) Compare the scale image and the actual scale.  
If a fine adjustment is required, switch to the manual correction mode with the magnification ratio display key and perform fine adjustment.
- 7) Manual correction mode (TEXT lamp ON)  
Enter the set value and press the start key.  
The set value is stored and a copy is made.



**<Adjustment specification>**

Mode	Specification	SIM	Set value	Set range
Main scanning direction magnification ratio	At normal: ±1.0%	SIM 48-1	Add 1: 0.1% increase Reduce 1: 0.1% decrease	1 ~ 99

- Error in the auto correction mode

Display	Content	Major cause
Copy quantity display "--"	The correction value calculated is over 5%.	<ul style="list-style-type: none"> <li>• Improper position of reference width line of the reference white plate</li> <li>• Improper installation of CCD unit</li> </ul>
Paper jam lamp ON	Reference line scanning error	<ul style="list-style-type: none"> <li>• Defective CCD</li> <li>• No reference white plate</li> </ul>

**(6) Sub scanning direction (scanning direction) magnification ratio adjustment (SIM 48-2, SIM 48-5)**
**a. OC mode in copying**

Note: • Before performing this adjustment, be sure to check that the CCD unit is properly installed.

- 1) Put a scale on the original table as shown below, and make a normal (100%) copy.

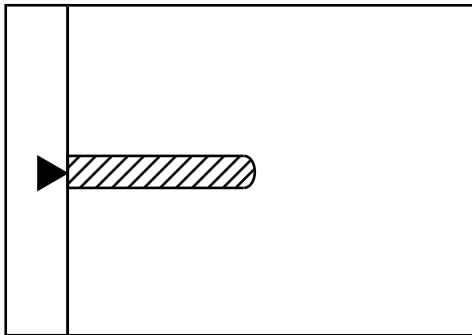

- 2) Compare the scale image and the actual image. If necessary, perform the following adjustment procedures.
- 3) Execute SIM 48-2.
- 4) After warmup, shading is performed and the current set value of the sub scanning direction magnification ratio is displayed on the display section in 2 digits.
- 5) Enter the set value and press the start key.  
The set value is stored and a copy is made.

**<Adjustment specification>**

Mode	Specification	SIM	Set value	Set range
Sub scanning direction magnification ratio (OC mode)	Normal ±1.0%	SIM 48-2	Add 1: 0.1% increase Reduce 1: 0.1% decrease	1 ~ 99

**b. SPF mode in copying**

Note: • Before performing this adjustment, be sure to check that the CCD unit is properly installed.

- Before performing this adjustment, the OC mode adjustment in copying must be completed.

- 1) Put a scale on the original table as shown below, and make a normal (100%) copy to make a test chart.

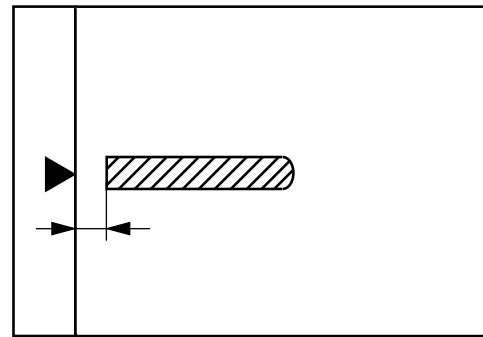

Note: Since the printed copy is used as a test chart, put the scale in parallel with the edge lines.

- 2) Set the test chart on the SPF and make a normal (100%) copy.
- 3) Compare the scale image and the actual image. If necessary, perform the following adjustment procedures.
- 4) Execute SIM 48-5.
- 5) After warmup, shading is performed and the current set value of the sub scanning direction magnification ratio is displayed on the display section in 2 digits.
- 6) Enter the set value and press the start key.  
The set value is stored and a copy is made.

**<Adjustment specification>**

Mode	Specification	SIM	Set value	Set range
Sub scanning direction magnification ratio (SPF mode)	Normal ±1.0%	SIM 48-5	Add 1: 0.1% increase Reduce 1: 0.1% decrease	1 ~ 99

**(7) Off center adjustment (SIM 50-13, SIM 50-16)**
**a. OC mode**

Note: • Before performing this adjustment, be sure to check that the paper off center is properly adjusted. (SIM 50-10)

- 1) Make a test chart as shown below and set it so that its center line is fit with the original guide center mark.  
\* To make a test chart, draw a line on A3 or 11" x 17" paper at the center in the paper transport direction.

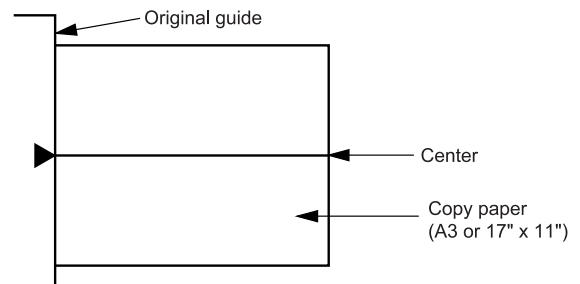

- 2) Make a normal copy from the manual paper feed tray, and compare the copy and the test chart.  
If necessary, perform the following adjustment procedures.
- 3) Execute SIM 50-13.
- 4) After warmup, shading is performed and the current set value of the off center adjustment is displayed on the display section in 2 digits.
- 5) Enter the set value and press the start key.  
The set value is stored and a copy is made.

## &lt;Adjustment specification&gt;

Mode	Specification	SIM	Set value	Set range
Original off center mode (OC mode)	Single: Center $\pm 2.0\text{mm}$	SIM 50-18	Add 1: 0.1mm shift to R side	1 ~ 99
	Duplex: Center $\pm 2.5\text{mm}$		Reduce 1: 0.1mm shift to L side	

**b. SPF mode**

Note: • Before performing this adjustment, be sure to check that the paper off center is properly adjusted.

- 1) Make a test chart for the center position adjustment and set it on the SPF.

## &lt;Adjustment specification&gt;

Draw a line on a paper in the scanning direction.

- 2) Make a normal copy from the manual paper feed tray, and compare the copy and the original test chart. If necessary, perform the following adjustment procedures.
- 3) Execute SIM 50-16.
- 4) After warmup, shading is performed and the current set value of the off center adjustment at each paper feed port is displayed on the display section in 2 digits.
- 5) Enter the set value and press the start key.  
The set value is stored and a copy is made.

## &lt;Adjustment specification&gt;

Mode	Specification	SIM	Set value	Set range
Original off center mode (SPF mode)	Single: Center $\pm 3.0\text{mm}$	SIM 50-16	Add 1: 0.1mm shift to R side	1 ~ 99
	Duplex: Center $\pm 3.5\text{mm}$		Reduce 1: 0.1mm shift to L side	

**(8) Original sensor adjustment (SIM 43-3)**

- 1) Execute SIM 41-2.
- 2) Set A3 (11" x 17") paper on the OC table.
- 3) Press the start key again.
- 4) The sensor level of the original sensor is automatically checked and the value with an original - 40 is made as the threshold value for scanning. (Automatic setting)
- 5) Execute SIM 43-3.
- 6) The light reception level of the original sensor is displayed.  
The first digit of the copy quantity display shows "A": Light reception level display  
The first digit of the copy quantity display shows "b": Original judgement level display  
(The mode selection is made with the magnification ratio display key.)
- 7) By changing the paper set on the original table, the original size LED sensed by the sensor is lighted.

**C. Image density adjustment****(1) Copy mode (SIM 46-1)**

- 1) Set a test chart (UKOG-0162FCZZ) on the OC table as shown below.

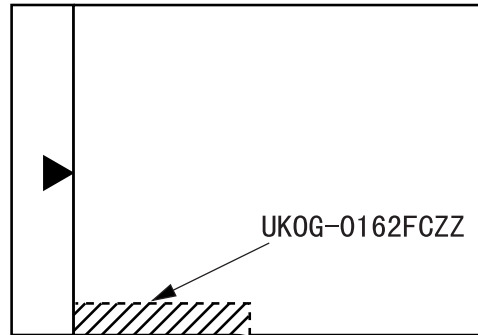

- 2) Put several sheets of A3 or 11" x 17" white paper on the test chart.
- 3) Execute SIM 46-1.
- 4) After warmup, shading is performed and the current set value of the density level is displayed on the display section in 2 digits.  
For mode selection, use the density select key.
- 5) Change the set value with the 10-key to adjust the copy image density.
- 6) Make a copy and check that the specification below is satisfied.

## &lt;Adjustment specification&gt;

Density mode	Display lamp	Exposure level	Sharp Gray Chart output	Set value	Set range
Auto	Auto	—	"3" is slightly copied.	The greater the set value is, the greater the density is.	1 ~ 99
Manual	Manual	3	"3" is slightly copied.		
Photo	Photo	3	"3" is slightly copied.	The smaller the set value is, the smaller the density is.	
Toner save	Manual/Photo	3	"3" is slightly copied.		

## [8] SIMULATION

### 1. Entering the simulation mode

Perform the following procedure to enter the simulation mode.

Clear key → Interruption key → Shift key → Interruption key → Start key → Sub code → Start key

### 2. Cancelling the simulation mode

When the all clear key is pressed, the simulation mode is cancelled.

When the interruption key is pressed, the process is interrupted and the screen returns to the sub code entering display.

### 3. List of simulations

Main code	Sub code	Contents
1	1	Mirror unit operation check
	2	Optical system sensor operation check
2	1	SPF aging
	2	SPF sensor operation check
	3	SPF motor forward rotation operation check
	4	SPF motor reverse rotation operation check
	8	SPF paper feed solenoid operation check
	9	SPF reverse solenoid operation check
	10	SPF paper exit gate solenoid operation check
3	2	Shifter job separator sensor operation check
	3	Shifter operation check
	4	Job separator operation check
	10	Job separator home position check
5	1	Operation panel display check
	2	Heater lamp lighting check, cooling fan motor operation check
	3	Copy lamp lighting check
6	1	Paper feed solenoid operation check
	10	Main cassette semi-circular roller drive
7	1	Aging with JAM with warmup time display
	2	Aging without JAM with warmup time display
	4	Warmup saving
	6	Intermittent aging (with paper)
	7	Intermittent aging (without paper)
	8	Warmup time display
8	1	Developing bias voltage output check
	2	Main charger voltage output check (Grid bias high mode)
	3	Main charger voltage output check (Grid bias low mode)
	6	Transfer charger voltage check
9	1	Duplex motor forward rotation operation check
	2	Duplex motor reverse rotation operation check
	4	Duplex motor rotation speed adjustment
	5	Duplex motor switchback time adjustment
	10	Toner motor operation check
14	Trouble (except for U2) cancel	
16	U2 trouble cancel	
17	PF trouble cancel	
20	1	Maintenance counter clear
21	1	Maintenance cycle setting
	2	Mini maintenance counter display
22	1	Maintenance counter display

Main code	Sub code	Contents	
22	2	Maintenance preset value display	
	3	JAM memory display	
	4	Total JAM counter display	
	5	Total counter display	
	6	Developing counter display	
	7	Developing preset counter value display	
	8	SPF counter display	
	9	Paper feed counter display	
	12	Drum counter display	
	14	Flash ROM version display	
	15	Trouble memory display	
	16	Duplex print counter display	
	17	Copy counter display	
	18	Printer counter display	
	19	Electronic sort counter display	
	20	FAX print counter display	
	21	Scanner counter display	
	24	1	JAM memory, JAM counter clear
		2	Trouble memory clear
		4	SPF counter clear
		5	Duplex counter clear
6		Paper feed counter clear	
7		Drum counter clear	
8		Copy counter clear	
9		Printer counter clear	
10		Electronic sort counter clear	
11		FAX print counter clear	
13		Scanner counter clear	
25		1	Main motor operation check
		10	Polygon motor operation check
26	1	Operation switch display	
	3	Auditor setting	
	5	Counter mode setting	
	6	Destination setting	
	22	Language setting	
	30	CE mark conformity control setting	
30	1	Machine sensor operation check	
41	2	OC document sensor adjustment	
	3	Document sensor light reception level display	
42	1	Developer counter clear	
43	1	Fusing temperature setting	
46	1	Copy density level adjustment	
	2	FAX density level adjustment	
48	1	Main scanning (front/rear) direction magnification ratio adjustment(Copy/FAX/OC-SPF common)	
	2	OC mode sub scanning direction magnification ratio adjustment in copying	
	5	SPF mode sub scanning direction magnification ratio adjustment in copying	
	6	OC mode sub scanning direction magnification ratio adjustment in FAX	
	7	SPF mode sub scanning direction magnification ratio adjustment in FAX	
	50	1	Copy image lead edge position adjustment
		10	Paper off center adjustment
13		OC mode document off center adjustment	
16		SPF mode document off center adjustment	
51	2	Resist amount adjustment	
63	1	Shading data check	

## 4. Contents of simulations

Main code	Sub code	Contents	Details of operation	Initial value	Set range				
1	1	Mirror unit operation check	Used to execute scanning at the speed corresponding to the set magnification ratio. <table border="1" style="width: 100%; border-collapse: collapse;"> <thead> <tr> <th style="width: 50%;">Key operation</th> <th style="width: 50%;">Display</th> </tr> </thead> <tbody> <tr> <td>Changing the magnification ratio: Fixed magnification ratio key</td> <td>Set magnification ratio: Fixed magnification ratio LED</td> </tr> </tbody> </table>	Key operation	Display	Changing the magnification ratio: Fixed magnification ratio key	Set magnification ratio: Fixed magnification ratio LED	100%	50 ~ 200%
	Key operation	Display							
Changing the magnification ratio: Fixed magnification ratio key	Set magnification ratio: Fixed magnification ratio LED								
2	Optical system sensor operation check	Used to check MHPS (Mirror home position sensor) ON/OFF state with the LED on the operation panel. <table border="1" style="width: 100%; border-collapse: collapse;"> <thead> <tr> <th style="width: 100%;">Display</th> </tr> </thead> <tbody> <tr> <td>&lt;Lighting when the sensor is ON&gt; MHPS: Paper empty LED</td> </tr> </tbody> </table>	Display	<Lighting when the sensor is ON> MHPS: Paper empty LED					
Display									
<Lighting when the sensor is ON> MHPS: Paper empty LED									
2	1	SPF aging	Used to perform SPF document transport. The paper size is not detected. (Excluding postcards, extra large sheet of 1m or greater.) With SPF installed: Single transport operation With RSPF installed: Duplex transport operation						
	2	SPF sensor operation check	Used to check sensors in SPF with the LED on the operation panel. <table border="1" style="width: 100%; border-collapse: collapse;"> <thead> <tr> <th style="width: 100%;">Display</th> </tr> </thead> <tbody> <tr> <td>&lt;Lighting at sensor ON&gt; PW1: JAM LED PW2: Paper empty LED PW3: Machine position JAM LED PW4: SPF JAM LED PL1: Manual paper feed tray select LED PL2: Second cassette position JAM LED P-IN: SPF select LED P-OUT: Main cassette select LED</td> </tr> </tbody> </table>	Display	<Lighting at sensor ON> PW1: JAM LED PW2: Paper empty LED PW3: Machine position JAM LED PW4: SPF JAM LED PL1: Manual paper feed tray select LED PL2: Second cassette position JAM LED P-IN: SPF select LED P-OUT: Main cassette select LED				
	Display								
	<Lighting at sensor ON> PW1: JAM LED PW2: Paper empty LED PW3: Machine position JAM LED PW4: SPF JAM LED PL1: Manual paper feed tray select LED PL2: Second cassette position JAM LED P-IN: SPF select LED P-OUT: Main cassette select LED								
	3	SPF motor forward rotation operation check	Used to rotate the SPF motor forward at the speed corresponding to the currently set magnification ratio for 10 sec.	100%	50 ~ 200%				
	4	SPF motor reverse rotation operation check	Used to rotate the SPF motor reversely for 10 sec.						
	8	SPF paper feed solenoid operation check	Used to drive the SPF paper feed solenoid (PSOL) at the cycle of 500msec ON and 500msec OFF 20 times.						
	9	SPF reverse solenoid operation check	Used to drive the SPF reverse solenoid (RSOL) at the cycle of 500msec ON and 500msec OFF 20 times.						
10	SPF paper exit gate solenoid operation check	Used to drive the SPF paper exit gate solenoid (GSOL) at the cycle of 500msec ON and 500msec OFF 20 times.							
11	SPF PS release solenoid operation check	Used to drive the SPF PS release solenoid at the cycle of 500msec ON and 500msec OFF 20 times.							
3	2	Shifter job separator sensor operation check	Used to check the sensors state in the shifter job separator with the LED on the operation panel. <table border="1" style="width: 100%; border-collapse: collapse;"> <thead> <tr> <th style="width: 100%;">Display</th> </tr> </thead> <tbody> <tr> <td>&lt;Lighting at sensor ON&gt; Shifter HP sensor: Machine position JAM LED Job separator HP sensor: SPF JAM LED Paper exit full sensor: Second cassette position JAM LED</td> </tr> </tbody> </table>	Display	<Lighting at sensor ON> Shifter HP sensor: Machine position JAM LED Job separator HP sensor: SPF JAM LED Paper exit full sensor: Second cassette position JAM LED				
	Display								
<Lighting at sensor ON> Shifter HP sensor: Machine position JAM LED Job separator HP sensor: SPF JAM LED Paper exit full sensor: Second cassette position JAM LED									
3	Shifter operation check	Used to drive the shifter motor at the speed of printing of A4 (8-1/2 × 11"). Pressing the start key or the clear all key moves the shifter to the home position. <table border="1" style="width: 100%; border-collapse: collapse;"> <thead> <tr> <th style="width: 100%;">Key operation</th> </tr> </thead> <tbody> <tr> <td>The shifter is moved to the home position: Start key or clear all key</td> </tr> </tbody> </table>	Key operation	The shifter is moved to the home position: Start key or clear all key					
Key operation									
The shifter is moved to the home position: Start key or clear all key									

Main code	Sub code	Contents	Details of operation	Initial value	Set range				
3	4	Job separator operation check	Used to drive the job separator one way. Pressing the clear key stops the job separator at the home position. <table border="1" data-bbox="618 226 1304 302"> <tr> <td>Key operation</td> </tr> <tr> <td>Stops at the home position: Clear all key</td> </tr> </table>	Key operation	Stops at the home position: Clear all key				
	Key operation								
Stops at the home position: Clear all key									
	10	Job separator home position check	Used to drive the job separator to the home position. Then it is shifted by the specified number of steps for check, and the position is made as the origin. It is shifted from the origin by the specified number of steps.						
5	1	Operation panel display check	Used to light all LED's on the operation panel for 5 sec.						
	2	Heater lamp lighting check, cooling fan motor operation check	Used to turn ON the heater lamp for 500msec and OFF for 500msec 5 times. At the same time, the cooling fan is rotated at a high speed. After checking the heater lamp operation, the cooling fan motor rotate at a low speed.						
	3	Copy lamp lighting check	Used to light the copy lamp for 5 sec. At that time, the copy lamp brightness can be changed with the density adjustment key. When this simulation is canceled, the copy lamp brightness is automatically adjusted. <table border="1" data-bbox="618 701 1304 777"> <tr> <td>Key operation</td> </tr> <tr> <td>Copy lamp brightness: Density adjustment key</td> </tr> </table>	Key operation	Copy lamp brightness: Density adjustment key				
Key operation									
Copy lamp brightness: Density adjustment key									
6	1	Paper feed solenoid operation check	When the start key is pressed, the selected paper feed solenoid is driven at the cycle of 500msec ON and 500msec OFF 20 times. <table border="1" data-bbox="618 863 1304 1608"> <thead> <tr> <th>Key operation</th> <th>Display</th> </tr> </thead> <tbody> <tr> <td>Solenoid selection: Tray select button</td> <td>&lt;Lighting at solenoid selection&gt; Main cassette paper feed solenoid: Main cassette select LED Multi manual paper feed solenoid: Manual paper feed select LED No. 2 cassette paper feed solenoid: No. 2 cassette select LED No. 3 cassette paper feed solenoid: No. 3 cassette select LED No. 4 cassette paper feed solenoid: No. 4 cassette select LED Resist roller solenoid: Machine position JAM LED No. 2 cassette transport solenoid: No. 2 cassette position JAM LED No. 3 cassette transport solenoid: No. 3 cassette position JAM LED No. 4 cassette transport solenoid: No. 4 cassette position JAM LED Paper out 1 solenoid: Paper empty LED Paper out 2 solenoid: SPF JAM LED Paper out 3 solenoid: SPF select LED</td> </tr> </tbody> </table>	Key operation	Display	Solenoid selection: Tray select button	<Lighting at solenoid selection> Main cassette paper feed solenoid: Main cassette select LED Multi manual paper feed solenoid: Manual paper feed select LED No. 2 cassette paper feed solenoid: No. 2 cassette select LED No. 3 cassette paper feed solenoid: No. 3 cassette select LED No. 4 cassette paper feed solenoid: No. 4 cassette select LED Resist roller solenoid: Machine position JAM LED No. 2 cassette transport solenoid: No. 2 cassette position JAM LED No. 3 cassette transport solenoid: No. 3 cassette position JAM LED No. 4 cassette transport solenoid: No. 4 cassette position JAM LED Paper out 1 solenoid: Paper empty LED Paper out 2 solenoid: SPF JAM LED Paper out 3 solenoid: SPF select LED		
	Key operation	Display							
Solenoid selection: Tray select button	<Lighting at solenoid selection> Main cassette paper feed solenoid: Main cassette select LED Multi manual paper feed solenoid: Manual paper feed select LED No. 2 cassette paper feed solenoid: No. 2 cassette select LED No. 3 cassette paper feed solenoid: No. 3 cassette select LED No. 4 cassette paper feed solenoid: No. 4 cassette select LED Resist roller solenoid: Machine position JAM LED No. 2 cassette transport solenoid: No. 2 cassette position JAM LED No. 3 cassette transport solenoid: No. 3 cassette position JAM LED No. 4 cassette transport solenoid: No. 4 cassette position JAM LED Paper out 1 solenoid: Paper empty LED Paper out 2 solenoid: SPF JAM LED Paper out 3 solenoid: SPF select LED								
	10	Main cassette semi-circular roller drive	Used to rotate the semi-circular roller of the main cassette one turn to face it downward.						
7	1	Aging with JAM with warmup time display	Used to start warmup and count and display the warmup time every second. After completion of warmup, count up is terminated and the ready lamp is lighted. When the clear key is pressed and the copy quantity is entered and the start key is pressed, copying is made to make the set quantity of copies. At that time, the paper size does not matter. <table border="1" data-bbox="618 1835 1304 1911"> <tr> <td>Key operation</td> </tr> <tr> <td>Copy quantity setting: Numeric keys</td> </tr> </table>	Key operation	Copy quantity setting: Numeric keys		1 ~ 9		
Key operation									
Copy quantity setting: Numeric keys									

Main code	Sub code	Contents	Details of operation	Initial value	Set range
7	2	Aging without JAM with warmup time display	Used to start warmup and count and display the warmup time every second. After completion of warmup, count up is terminated and the ready lamp is lighted. When the clear key is pressed and the copy quantity is entered and the start key is pressed, copying is made to make the set quantity of copies. At that time, the paper size does not matter.  <div style="border: 1px solid black; padding: 2px; text-align: center;">Key operation</div> <div style="border: 1px solid black; padding: 2px;">Copy quantity setting: Numeric keys</div>		1 ~ 99
	4	Warmup saving	Used to bring the machine to the ready state without warmup.		
	6	Intermittent aging (with paper)	After completion of warmup, counting is stopped and the ready lamp is lighted. When the copy quantity is entered and the start key is pressed, copying is made to make the set quantity of copies. After 3 sec standby, copying is made again to make the set quantity of copies. After that this operation is repeated. The paper size does not matter.  <div style="border: 1px solid black; padding: 2px; text-align: center;">Key operation</div> <div style="border: 1px solid black; padding: 2px;">Copy quantity setting: Numeric keys</div>		1 ~ 99
	7	Intermittent aging (without paper)	After completion of warmup, counting is stopped and the ready lamp is lighted. When the copy quantity is entered and the start key is pressed, copying is made to make the set quantity of copies. After 3 sec standby, copying is made again to make the set quantity of copies. After that this operation is repeated. The paper size does not matter.  <div style="border: 1px solid black; padding: 2px; text-align: center;">Key operation</div> <div style="border: 1px solid black; padding: 2px;">Copy quantity setting: Numeric keys</div>		1 ~ 99
8	8	Warmup time display	Used to count and display the warmup time from 0 at every second.		
	1	Developing bias voltage output check	Used to output the developing bias for 30 sec. For the adjustment procedure of the developing bias, refer to the previous descriptions.		
	2	Main charger voltage output check (Grid bias high mode)	Used to output the main charger grid bias voltage at the high mode for 30 sec. For the adjustment procedure of the main charger grid bias voltage, refer to the previous descriptions.		
	3	Main charger voltage output check (Grid bias low mode)	Used to output the main charger grid bias voltage at the low mode for 30 sec. For the adjustment procedure of the main charger grid bias voltage, refer to the previous descriptions.		
9	6	Transfer charger voltage check	Used to output the transfer charger voltage for 30 sec. For the adjustment procedure of the transfer charger voltage, refer to the previous descriptions.		
	1	Duplex motor forward rotation operation check	Used to rotate the duplex motor forward for 30 sec.		
	2	Duplex motor reverse rotation operation check	Used to rotate the duplex motor reversely for 30 sec.		
	4	Duplex motor rotation speed adjustment	After completion of warmup, the ready lamp is lighted and the currently set duplex motor rotation speed set value is displayed. When the set value is entered and the start key is pressed, the set value is stored.  <div style="border: 1px solid black; padding: 2px; text-align: center;">Key operation</div> <div style="border: 1px solid black; padding: 2px;">Duplex motor rotation speed set value: Numeric keys</div>		
	5	Duplex motor switchback time adjustment	After completion of warmup, the ready lamp is lighted and the currently set duplex motor switchback time set value is displayed. When the set value is entered and the start key is pressed, the set value is stored.  <div style="border: 1px solid black; padding: 2px; text-align: center;">Key operation</div> <div style="border: 1px solid black; padding: 2px;">Duplex motor switchback time set value: Numeric keys</div>		
10		Toner motor operation check	Used to operate the toner motor for 30 sec. Note: If this simulation is executed with the toner hopper installed, toner is automatically supplied to the developer. Be careful of overtoner.		
14		Trouble (except for U2) cancel	Used to cancel troubles except for U2.		
16		U2 trouble cancel	Used to cancel U2 trouble.		
17		PF trouble cancel	Used to cancel PF trouble.		

Main code	Sub code	Contents	Details of operation	Initial value	Set range							
20	1	Maintenance counter clear	Used to clear the maintenance counter. *2									
21	1	Maintenance cycle setting	Used to display the currently set maintenance cycle at the numbers shown at right. When the set value is entered and the start key is pressed, the set value is stored. <table border="1" style="width: 100%;"><thead><tr><th>Key operation/Display</th></tr></thead><tbody><tr><td>0: 2500 sheets</td></tr><tr><td>1: 5000 sheets</td></tr><tr><td>2: 15000 sheets</td></tr><tr><td>3: 30000 sheets</td></tr><tr><td>4: 150000 sheets</td></tr><tr><td>5: FREE (999999 sheets)</td></tr></tbody></table>	Key operation/Display	0: 2500 sheets	1: 5000 sheets	2: 15000 sheets	3: 30000 sheets	4: 150000 sheets	5: FREE (999999 sheets)		
	Key operation/Display											
0: 2500 sheets												
1: 5000 sheets												
2: 15000 sheets												
3: 30000 sheets												
4: 150000 sheets												
5: FREE (999999 sheets)												
2	Mini maintenance counter display	Used to display the currently set mini maintenance cycle at the numbers shown at right. When the set value is entered and the start key is pressed, the set value is stored. <table border="1" style="width: 100%;"><thead><tr><th>Key operation/Display</th></tr></thead><tbody><tr><td>0: 2500 sheets</td></tr><tr><td>1: 5000 sheets</td></tr><tr><td>2: 10000 sheets</td></tr><tr><td>3: FREE (999999 sheets)</td></tr></tbody></table>	Key operation/Display	0: 2500 sheets	1: 5000 sheets	2: 10000 sheets	3: FREE (999999 sheets)					
Key operation/Display												
0: 2500 sheets												
1: 5000 sheets												
2: 10000 sheets												
3: FREE (999999 sheets)												
22	1	Maintenance counter display	Used to display the current maintenance counter value. *1									
	2	Maintenance preset value display	Used to display the current maintenance preset value (set with SIM 21-1). *1									
	3	JAM memory display	Used to display a JAM generated during copying on the JAM position display on the operation panel. Max. 30 recent jams are stored. <table border="1" style="width: 100%;"><thead><tr><th>Key operation</th><th>Display</th></tr></thead><tbody><tr><td>JAM history select: Magnification ratio key</td><td>The history number (1 ~ 30) is displayed on the display. The JAM position LED corresponding to the history number is lighted.</td></tr></tbody></table>	Key operation	Display	JAM history select: Magnification ratio key	The history number (1 ~ 30) is displayed on the display. The JAM position LED corresponding to the history number is lighted.					
	Key operation	Display										
	JAM history select: Magnification ratio key	The history number (1 ~ 30) is displayed on the display. The JAM position LED corresponding to the history number is lighted.										
	4	Total JAM counter display	Used to display the current total JAM counter value. *1									
	5	Total counter display	Used to display the current total counter value. *1									
	6	Developing counter display	Used to display the current developing unit counter value. *1									
	7	Developing preset counter value display	Used to display the current mini maintenance preset value (set with SIM 21-2). *1									
	8	SPF counter display	Used to display the current SPF counter value. *1									
9	Paper feed counter display	Used to display the current paper feed counter value for each paper feed port. *1 <table border="1" style="width: 100%;"><thead><tr><th>Key operation</th></tr></thead><tbody><tr><td>Paper feed port selection: Tray select key</td></tr></tbody></table>	Key operation	Paper feed port selection: Tray select key								
Key operation												
Paper feed port selection: Tray select key												
12	Drum counter display	Used to display the current drum counter value. *1										
14	Flash ROM version display	Used to display the version number of the flash ROM of each PWB.										
15	Trouble memory display	Used to display the actually occurred trouble codes on the display on the operation panel. When the start key is pressed during the main code display, the sub code is displayed. Max. 20 recent trouble codes are stored. <table border="1" style="width: 100%;"><thead><tr><th>Key operation</th><th>Display</th></tr></thead><tbody><tr><td>Sub code display: Start key Trouble code history select: Magnification ratio display key</td><td>Hysteresis 1 → 10: The upper digit of display "A" ~ "J" lights up. Hysteresis 11 → 20: The upper digit of display "A: ~ "J" blinks. • Display without trouble code Main code: "----" Sub code: "00"</td></tr></tbody></table>	Key operation	Display	Sub code display: Start key Trouble code history select: Magnification ratio display key	Hysteresis 1 → 10: The upper digit of display "A" ~ "J" lights up. Hysteresis 11 → 20: The upper digit of display "A: ~ "J" blinks. • Display without trouble code Main code: "----" Sub code: "00"						
Key operation	Display											
Sub code display: Start key Trouble code history select: Magnification ratio display key	Hysteresis 1 → 10: The upper digit of display "A" ~ "J" lights up. Hysteresis 11 → 20: The upper digit of display "A: ~ "J" blinks. • Display without trouble code Main code: "----" Sub code: "00"											

\*1: Each counter display method

To display 12345: 123 (0.75 sec) → Blank (0.35sec) → 456 (0.75 sec) → Blank (1.0 sec) → repetition

\*2: Display after clearing each counter

000 (0.75 sec) → Blank (0.35sec) → 000 (0.75 sec) → Blank (1.05 sec) → Repetition

Main code	Sub code	Contents	Details of operation	Initial value	Set range				
22	16	Duplex print counter display	Used to display the current duplex print counter value. *1						
	17	Copy counter display	Used to display the current copy counter value. *1						
	18	Printer counter display	Used to display the current printer counter value. *1						
	19	Electronic sort counter display	Used to display the current electronic sort counter value. *1						
	20	FAX print counter display	Used to display the current FAX print counter value. *1						
	21	Scanner counter display	Used to display the current scanner counter value.						
24	1	JAM memory, JAM counter clear	Used to clear the JAM memory and the JAM counter. *2						
	2	Trouble memory clear	Used to clear the trouble memory. *2						
	4	SPF counter clear	Used to clear the SPF counter. *2						
	5	Duplex counter clear	Used to clear the duplex counter. *2						
	6	Paper feed counter clear	Used to clear the paper feed counter. *2						
	7	Drum counter clear	Used to clear the drum counter. *2						
	8	Copy counter clear	Used to clear the copy counter. *2						
	9	Printer counter clear	Used to clear the printer counter. *2						
	10	Electronic sort counter clear	Used to clear the electronic sort counter. *2						
	11	FAX print counter clear	Used to clear the FAX print counter. *2						
25	1	Main motor operation check	Used to drive the main motor for 30 sec. At that time, the cooling motor rotates at a low speed. When the developing unit is installed, the developing bias, the grid, and the main charger are driven. When the developing unit is not installed, only the main motor is driven.						
	10	Polygon motor operation check	Used to drive the polygon motor for 30 sec.						
26	1	Operation switch display	Used to display the installed option on the operation panel. (The LED corresponding to the installed option is lighted.) <table border="1" data-bbox="542 1083 1227 1644"> <thead> <tr> <th>Key operation</th> <th>Display</th> </tr> </thead> <tbody> <tr> <td>Display select: Magnification ratio key</td> <td>&lt;Lighting with an option installed&gt; <b>When "A" is displayed:</b> Shifter: Paper empty LED Job separator: JAM LED SPF: SPF select LED RSPF: SPF JAM LED Dehumidifying heater: Main body JAM LED Simplex mode: Multi manual paper feed select LED <b>When "B" is displayed:</b> Cassette (2nd step): No. 2 cassette select LED Cassette (3rd step): No. 3 cassette select LED Cassette (4th step): No. 4 cassette select LED Memory installed: Paper empty LED FAX: JAM LED Printer: Main body JAM LED ERDH: Main cassette select LED 16CPM: SPF JAM LED 20CPM: SPF select LED Document sensor: Auto paper select LED</td> </tr> </tbody> </table>	Key operation	Display	Display select: Magnification ratio key	<Lighting with an option installed> <b>When "A" is displayed:</b> Shifter: Paper empty LED Job separator: JAM LED SPF: SPF select LED RSPF: SPF JAM LED Dehumidifying heater: Main body JAM LED Simplex mode: Multi manual paper feed select LED <b>When "B" is displayed:</b> Cassette (2nd step): No. 2 cassette select LED Cassette (3rd step): No. 3 cassette select LED Cassette (4th step): No. 4 cassette select LED Memory installed: Paper empty LED FAX: JAM LED Printer: Main body JAM LED ERDH: Main cassette select LED 16CPM: SPF JAM LED 20CPM: SPF select LED Document sensor: Auto paper select LED		
	Key operation	Display							
Display select: Magnification ratio key	<Lighting with an option installed> <b>When "A" is displayed:</b> Shifter: Paper empty LED Job separator: JAM LED SPF: SPF select LED RSPF: SPF JAM LED Dehumidifying heater: Main body JAM LED Simplex mode: Multi manual paper feed select LED <b>When "B" is displayed:</b> Cassette (2nd step): No. 2 cassette select LED Cassette (3rd step): No. 3 cassette select LED Cassette (4th step): No. 4 cassette select LED Memory installed: Paper empty LED FAX: JAM LED Printer: Main body JAM LED ERDH: Main cassette select LED 16CPM: SPF JAM LED 20CPM: SPF select LED Document sensor: Auto paper select LED								
3	Auditor setting	Used to display the current auditor setting with the numbers at right. After entering the set value, press the start key, and the set value is stored. <table border="1" data-bbox="542 1755 1227 1881"> <thead> <tr> <th>Key operation/Display</th> </tr> </thead> <tbody> <tr> <td>0: Built-in auditor</td> </tr> <tr> <td>1: Coin vendor</td> </tr> <tr> <td>2: Others</td> </tr> </tbody> </table>	Key operation/Display	0: Built-in auditor	1: Coin vendor	2: Others			
Key operation/Display									
0: Built-in auditor									
1: Coin vendor									
2: Others									

\*1: Each counter display method  
To display 12345: 123 (0.75 sec) → Blank (0.35sec) → 456 (0.75 sec) → Blank (1.0 sec) → repetition

\*2: Display after clearing each counter  
000 (0.75 sec) → Blank (0.35sec) → 000 (0.75 sec) → Blank (1.05 sec) → Repetition



Main code	Sub code	Contents	Details of operation	Initial value	Set range														
26	5	Counter mode setting	<p>Used to set the print counter mode in A3 or 11" × 17". Used to display the currently set counter value with the numbers at right. After entering the set value, press the start key, and the set value is stored.</p> <table border="1"> <thead> <tr> <th colspan="2">Key operation/Display</th> </tr> </thead> <tbody> <tr> <td>0: Total/Developer = 2 counts</td> <td>Maintenance = 2 counts</td> </tr> <tr> <td>1: Total/Developer = 1 count</td> <td>Maintenance = 2 counts</td> </tr> <tr> <td>2: Total/Developer = 2 counts</td> <td>Maintenance = 1 count</td> </tr> <tr> <td>3: Total/Developer = 1 count</td> <td>Maintenance = 1 count</td> </tr> </tbody> </table>	Key operation/Display		0: Total/Developer = 2 counts	Maintenance = 2 counts	1: Total/Developer = 1 count	Maintenance = 2 counts	2: Total/Developer = 2 counts	Maintenance = 1 count	3: Total/Developer = 1 count	Maintenance = 1 count						
Key operation/Display																			
0: Total/Developer = 2 counts	Maintenance = 2 counts																		
1: Total/Developer = 1 count	Maintenance = 2 counts																		
2: Total/Developer = 2 counts	Maintenance = 1 count																		
3: Total/Developer = 1 count	Maintenance = 1 count																		
	6	Destination setting	<p>Used to display the current destination setting with the numbers at right. After entering the set value, press the start key, and the set value is stored.</p> <table border="1"> <thead> <tr> <th colspan="2">Key operation/Display</th> </tr> </thead> <tbody> <tr><td>0: Japan</td></tr> <tr><td>1: USA (Inch series)</td></tr> <tr><td>2: Canada (Inch series)</td></tr> <tr><td>3: Germany (AB series)</td></tr> <tr><td>4: UK (AB series)</td></tr> <tr><td>5: Australia (AB series)</td></tr> <tr><td>6: France (AB series)</td></tr> <tr><td>7: EX inch series</td></tr> <tr><td>8: EX AB series</td></tr> <tr><td>9: EX inch series (FC conformity)</td></tr> <tr><td>10: EX AB series (FC conformity)</td></tr> <tr><td>11: Taiwan, China (AB series)</td></tr> </tbody> </table>	Key operation/Display		0: Japan	1: USA (Inch series)	2: Canada (Inch series)	3: Germany (AB series)	4: UK (AB series)	5: Australia (AB series)	6: France (AB series)	7: EX inch series	8: EX AB series	9: EX inch series (FC conformity)	10: EX AB series (FC conformity)	11: Taiwan, China (AB series)		
Key operation/Display																			
0: Japan																			
1: USA (Inch series)																			
2: Canada (Inch series)																			
3: Germany (AB series)																			
4: UK (AB series)																			
5: Australia (AB series)																			
6: France (AB series)																			
7: EX inch series																			
8: EX AB series																			
9: EX inch series (FC conformity)																			
10: EX AB series (FC conformity)																			
11: Taiwan, China (AB series)																			
	22	Language setting	<p>Used to display the current setting of the language information with the number at right. After entering the set value, press the start key, and the set value is stored.</p> <table border="1"> <thead> <tr> <th colspan="2">Key operation/Display</th> </tr> </thead> <tbody> <tr><td>0: Japanese</td></tr> <tr><td>1: English</td></tr> <tr><td>2: French</td></tr> <tr><td>3: German</td></tr> <tr><td>4: Italian</td></tr> <tr><td>5: Dutch</td></tr> <tr><td>6: Swedish</td></tr> <tr><td>7: Spanish</td></tr> </tbody> </table>	Key operation/Display		0: Japanese	1: English	2: French	3: German	4: Italian	5: Dutch	6: Swedish	7: Spanish						
Key operation/Display																			
0: Japanese																			
1: English																			
2: French																			
3: German																			
4: Italian																			
5: Dutch																			
6: Swedish																			
7: Spanish																			
	30	CE mark conformity control setting	<p>Used to display the current setting of CE mark conformity control with the number at right. After entering the set value, press the start key, and the set value is stored.</p> <table border="1"> <thead> <tr> <th colspan="2">Key operation/Display</th> </tr> </thead> <tbody> <tr><td>0: CE mark control OFF</td></tr> <tr><td>1: CE mark control ON</td></tr> </tbody> </table>	Key operation/Display		0: CE mark control OFF	1: CE mark control ON												
Key operation/Display																			
0: CE mark control OFF																			
1: CE mark control ON																			
30	1	Machine sensor operation check	<p>Used to check the sensors in the machine transport system with LED on the operation panel.</p> <table border="1"> <thead> <tr> <th colspan="2">Display</th> </tr> </thead> <tbody> <tr><td>&lt;Lighting at sensor ON&gt;</td></tr> <tr><td>Paper entry sensor: Machine position JAM LED</td></tr> <tr><td>Duplex sensor: SPF JAM LED</td></tr> <tr><td>Paper exit sensor: JAM LED</td></tr> <tr><td>No. 2 cassette transport sensor: No. 2 cassette position JAM LED</td></tr> <tr><td>No. 3 cassette transport sensor: No. 3 cassette position JAM LED</td></tr> <tr><td>No. 4 cassette transport sensor: No. 4 cassette position JAM LED</td></tr> </tbody> </table>	Display		<Lighting at sensor ON>	Paper entry sensor: Machine position JAM LED	Duplex sensor: SPF JAM LED	Paper exit sensor: JAM LED	No. 2 cassette transport sensor: No. 2 cassette position JAM LED	No. 3 cassette transport sensor: No. 3 cassette position JAM LED	No. 4 cassette transport sensor: No. 4 cassette position JAM LED							
Display																			
<Lighting at sensor ON>																			
Paper entry sensor: Machine position JAM LED																			
Duplex sensor: SPF JAM LED																			
Paper exit sensor: JAM LED																			
No. 2 cassette transport sensor: No. 2 cassette position JAM LED																			
No. 3 cassette transport sensor: No. 3 cassette position JAM LED																			
No. 4 cassette transport sensor: No. 4 cassette position JAM LED																			
41	2	OC document sensor adjustment	<p>Used to read the document sensor input value with paper and perform the sensor detection level adjustment. For the adjustment procedure of the document sensor input value, refer to the previous descriptions.</p>																

Main code	Sub code	Contents	Details of operation	Initial value	Set range								
41	3	Document sensor light reception level display	Used to display the light reception level and the detection level of the document sensor. (The sensor level adjusted with SIM 41-2 is displayed.) <table border="1"> <thead> <tr> <th>Key operation</th> <th>Display</th> </tr> </thead> <tbody> <tr> <td>Light reception/Detection level select: Magnification ratio display key</td> <td>Display at the 3rd digit "A": Light reception level display "b": Document detection level lighting LED</td> </tr> <tr> <td>Sensor select: Magnification ratio select key</td> <td>Sensor A: A3 document size LED Sensor B: A4 document size LED Sensor C: A4R document size LED Sensor D: B4 document size LED</td> </tr> </tbody> </table>	Key operation	Display	Light reception/Detection level select: Magnification ratio display key	Display at the 3rd digit "A": Light reception level display "b": Document detection level lighting LED	Sensor select: Magnification ratio select key	Sensor A: A3 document size LED Sensor B: A4 document size LED Sensor C: A4R document size LED Sensor D: B4 document size LED				
Key operation	Display												
Light reception/Detection level select: Magnification ratio display key	Display at the 3rd digit "A": Light reception level display "b": Document detection level lighting LED												
Sensor select: Magnification ratio select key	Sensor A: A3 document size LED Sensor B: A4 document size LED Sensor C: A4R document size LED Sensor D: B4 document size LED												
42	1	Developer counter clear	Used to clear the developer counter. *2										
43	1	Fusing temperature setting	Used to display the current setting of the fusing temperature with the number at right. After selecting the fusing temperature with the magnification ratio display key, press the start key, and the set value is stored. <table border="1"> <thead> <tr> <th>Key operation</th> </tr> </thead> <tbody> <tr> <td>Fusing temperature select: Magnification ratio display key</td> </tr> </tbody> </table>	Key operation	Fusing temperature select: Magnification ratio display key								
Key operation													
Fusing temperature select: Magnification ratio display key													
46	1	Copy density level adjustment	After completion of warmup, shading is performed and the currently set copy density level is displayed. For the adjustment procedure, refer to the previous descriptions. <table border="1"> <thead> <tr> <th>Key operation</th> <th>Display</th> </tr> </thead> <tbody> <tr> <td>Mode select: Mode select key</td> <td>&lt;LED lighting at each mode selection&gt; Auto mode: AE LED Manual mode: TEXT LED Photo mode: PHOTO LED Toner save mode: TEXT/PHOTO LED</td> </tr> </tbody> </table>	Key operation	Display	Mode select: Mode select key	<LED lighting at each mode selection> Auto mode: AE LED Manual mode: TEXT LED Photo mode: PHOTO LED Toner save mode: TEXT/PHOTO LED		1 ~ 99				
Key operation	Display												
Mode select: Mode select key	<LED lighting at each mode selection> Auto mode: AE LED Manual mode: TEXT LED Photo mode: PHOTO LED Toner save mode: TEXT/PHOTO LED												
	2	FAX density level adjustment	After completion of warmup, shading is performed and the currently set FAX density level is displayed. For the adjustment procedure, refer to the previous descriptions. <table border="1"> <thead> <tr> <th>Key operation</th> <th>Display</th> </tr> </thead> <tbody> <tr> <td>Mode select: Mode select key</td> <td>&lt;LED lighting at each mode selection&gt; Standard mode: Standard LED Small character mode: Small character LED Fine mode: Fine LED Ultra fine mode: Ultra fine LED Photo mode: Photo LED</td> </tr> </tbody> </table>	Key operation	Display	Mode select: Mode select key	<LED lighting at each mode selection> Standard mode: Standard LED Small character mode: Small character LED Fine mode: Fine LED Ultra fine mode: Ultra fine LED Photo mode: Photo LED		1 ~ 99				
Key operation	Display												
Mode select: Mode select key	<LED lighting at each mode selection> Standard mode: Standard LED Small character mode: Small character LED Fine mode: Fine LED Ultra fine mode: Ultra fine LED Photo mode: Photo LED												
48	1	Main scanning (front/rear) direction magnification ratio adjustment (Copy/FAX/OC-SPF common)	After completion of warmup, shading is performed and the currently set main scanning (front/rear) direction magnification ratio adjustment is performed. For the adjustment procedure, refer to the previous descriptions. <table border="1"> <thead> <tr> <th>Key operation</th> <th>Display</th> </tr> </thead> <tbody> <tr> <td>Adjustment mode select: Magnification ratio key</td> <td>Auto magnification ratio adjustment: AE LED</td> </tr> <tr> <td>Manual main scanning direction magnification ratio adjustment</td> <td>Manual magnification ratio adjustment: TEXT LED</td> </tr> <tr> <td>Set value: Numeric keys</td> <td></td> </tr> </tbody> </table>	Key operation	Display	Adjustment mode select: Magnification ratio key	Auto magnification ratio adjustment: AE LED	Manual main scanning direction magnification ratio adjustment	Manual magnification ratio adjustment: TEXT LED	Set value: Numeric keys			1 ~ 99
Key operation	Display												
Adjustment mode select: Magnification ratio key	Auto magnification ratio adjustment: AE LED												
Manual main scanning direction magnification ratio adjustment	Manual magnification ratio adjustment: TEXT LED												
Set value: Numeric keys													

\*1: Each counter display method  
To display 12345: 123 (0.75 sec) → Blank (0.35sec) → 456 (0.75 sec) → Blank (1.0 sec) → repetition

\*2: Display after clearing each counter  
000 (0.75 sec) → Blank (0.35sec) → 000 (0.75 sec) → Blank (1.05 sec) → Repetition

Main code	Sub code	Contents	Details of operation	Initial value	Set range				
48	2	OC mode sub scanning direction magnification ratio adjustment in copying	<p>After completion of warmup, shading is performed and the currently set OC mode sub scanning direction magnification ratio adjustment in copying is performed. For the adjustment procedure, refer to the previous descriptions.</p> <table border="1"> <thead> <tr> <th colspan="2">Key operation</th> </tr> </thead> <tbody> <tr> <td colspan="2">OC mode sub scanning direction copy magnification ratio in copying: Numeric keys</td> </tr> </tbody> </table>	Key operation		OC mode sub scanning direction copy magnification ratio in copying: Numeric keys			1 ~ 99
	Key operation								
	OC mode sub scanning direction copy magnification ratio in copying: Numeric keys								
	5	SPF mode sub scanning direction magnification ratio adjustment in copying	<p>After completion of warmup, shading is performed and the currently set OC mode sub scanning direction magnification ratio adjustment in copying is performed. For the adjustment procedure, refer to the previous descriptions.</p> <table border="1"> <thead> <tr> <th colspan="2">Key operation</th> </tr> </thead> <tbody> <tr> <td colspan="2">SPF mode sub scanning direction magnification ratio in copying: Numeric keys</td> </tr> </tbody> </table>	Key operation		SPF mode sub scanning direction magnification ratio in copying: Numeric keys			1 ~ 99
Key operation									
SPF mode sub scanning direction magnification ratio in copying: Numeric keys									
6	OC mode sub scanning direction magnification ratio adjustment in FAX	<p>After completion of warmup, shading is performed and the currently set OC mode sub scanning direction magnification ratio adjustment in FAX is performed. For the adjustment procedure, refer to the previous descriptions.</p> <table border="1"> <thead> <tr> <th colspan="2">Key operation</th> </tr> </thead> <tbody> <tr> <td colspan="2">OC mode sub scanning direction magnification ratio in FAX: Numeric keys</td> </tr> </tbody> </table>	Key operation		OC mode sub scanning direction magnification ratio in FAX: Numeric keys			1 ~ 99	
Key operation									
OC mode sub scanning direction magnification ratio in FAX: Numeric keys									
7	SPF mode sub scanning direction magnification ratio adjustment in FAX	<p>After completion of warmup, shading is performed and the currently set SPF mode sub scanning direction magnification ratio in FAX is performed. For the adjustment procedure, refer to the previous descriptions.</p> <table border="1"> <thead> <tr> <th colspan="2">Key operation</th> </tr> </thead> <tbody> <tr> <td colspan="2">SPF mode sub scanning direction magnification ratio in FAX: Numeric keys</td> </tr> </tbody> </table>	Key operation		SPF mode sub scanning direction magnification ratio in FAX: Numeric keys			1 ~ 99	
Key operation									
SPF mode sub scanning direction magnification ratio in FAX: Numeric keys									
50	1	Copy image position adjustment	<p>After completion of warmup, shading is performed and the currently set value is displayed. For the adjustment procedure, refer to the previous descriptions.</p> <table border="1"> <thead> <tr> <th>Key operation</th> <th>Display</th> </tr> </thead> <tbody> <tr> <td>Adjustment mode select: Exposure mode select key Set value: Numeric keys</td> <td>Auto: Laser radiation timing adjustment Manual: Lead edge void adjustment Photo: Left edge void adjustment Auto + Manual + Photo: Rear edge void adjustment</td> </tr> </tbody> </table>	Key operation	Display	Adjustment mode select: Exposure mode select key Set value: Numeric keys	Auto: Laser radiation timing adjustment Manual: Lead edge void adjustment Photo: Left edge void adjustment Auto + Manual + Photo: Rear edge void adjustment		1 ~ 99
	Key operation	Display							
Adjustment mode select: Exposure mode select key Set value: Numeric keys	Auto: Laser radiation timing adjustment Manual: Lead edge void adjustment Photo: Left edge void adjustment Auto + Manual + Photo: Rear edge void adjustment								
10	Paper off center adjustment	<p>After completion of warmup, shading is performed and the currently set off center adjustment of each paper feed port is displayed. For the adjustment procedure, refer to the previous descriptions.</p> <table border="1"> <thead> <tr> <th>Key operation</th> <th>Display</th> </tr> </thead> <tbody> <tr> <td>Paper feed port tray select: Paper select key Off center adjustment value: numeric keys</td> <td>Main cassette: Main cassette select LED Manual paper feed: Manual feed select LED No. 2 cassette: No. 2 cassette select LED No. 3 cassette: No. 3 cassette select LED No. 4 cassette: No. 4 cassette select LED</td> </tr> </tbody> </table>	Key operation	Display	Paper feed port tray select: Paper select key Off center adjustment value: numeric keys	Main cassette: Main cassette select LED Manual paper feed: Manual feed select LED No. 2 cassette: No. 2 cassette select LED No. 3 cassette: No. 3 cassette select LED No. 4 cassette: No. 4 cassette select LED			
Key operation	Display								
Paper feed port tray select: Paper select key Off center adjustment value: numeric keys	Main cassette: Main cassette select LED Manual paper feed: Manual feed select LED No. 2 cassette: No. 2 cassette select LED No. 3 cassette: No. 3 cassette select LED No. 4 cassette: No. 4 cassette select LED								

Main code	Sub code	Contents	Details of operation	Initial value	Set range		
50	13	OC mode document off center adjustment	<p>After completion of warmup, shading is performed and the currently set off center adjustment value for the document in OC reading is displayed. For the adjustment procedure, refer to the previous descriptions.</p> <table border="1"> <tr> <td>Key operation</td> </tr> <tr> <td>Off center adjustment value: Numeric keys</td> </tr> </table>	Key operation	Off center adjustment value: Numeric keys		
	Key operation						
Off center adjustment value: Numeric keys							
	16	SPF mode document off center adjustment	<p>After completion of warmup, shading is performed and the currently set off center adjustment value for the document in SPF reading is displayed. For the adjustment procedure, refer to the previous descriptions.</p> <table border="1"> <tr> <td>Key operation</td> </tr> <tr> <td>Off center adjustment value: Numeric keys</td> </tr> </table>	Key operation	Off center adjustment value: Numeric keys		
Key operation							
Off center adjustment value: Numeric keys							
51	2	Resist amount adjustment	<p>After completion of warmup, shading is performed and the currently set resist amount adjustment value is displayed.</p> <table border="1"> <tr> <td>Key operation</td> </tr> <tr> <td>Resist amount adjustment: Numeric keys</td> </tr> </table>	Key operation	Resist amount adjustment: Numeric keys		
Key operation							
Resist amount adjustment: Numeric keys							
63	1	Shading data check	<p>The copy lamp is shifted to the shading position and it is lighted with the reference voltage at AD conversion fixed (<math>V_{ref-} = 0.5V</math>, <math>V_{ref+} = 4.5V</math>). This state is kept for 10 sec, and the level of one pixel at the center is displayed for each second.</p> <table border="1"> <tr> <td>Display</td> </tr> <tr> <td>Display section: Shading data</td> </tr> </table>	Display	Display section: Shading data		
Display							
Display section: Shading data							

## [9] USER PROGRAM

The factory setting can be changed according to the operating conditions.



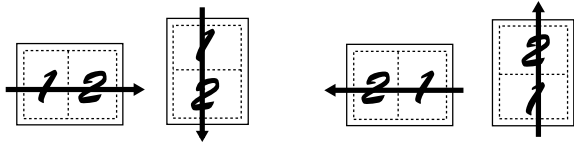
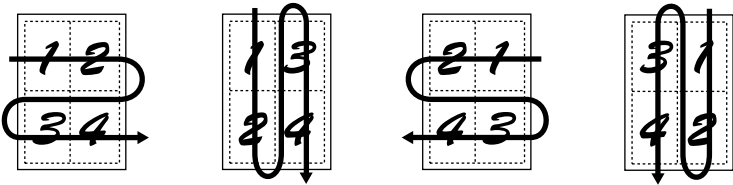



### 1. User program functions

Function	Outline	Default
Auto clear	When a certain time is passed after completion of the machine operation, the mode is returned to the initial state automatically. The time to return to the initial state can be set in the range of 30 ~ 120 sec by the unit of 30 sec. This function can be canceled.	60 sec
Pre-heat	When the machine is left unused with the power ON, the power consumption level is automatically lowered to about 60Wh (*1). The time to operate this function can be set in the range of 30 sec ~ 120 sec by the unit of 30 sec. This function can be canceled. When this function operates, the pre-heat lamp on the operation panel lights up. To cancel the pre-heat state, press any key on the operation panel. (When the START key is pressed, pre-heat is canceled and copying is started.) This function is canceled with the document is set or the tray is pulled out.	90 sec
Auto power shut off passing time	When the machine is left unused with the power ON, the power consumption is automatically lowered to about 4.8Wh (*1). The time to operate this function can be set in the range of 30 min to 240 min. When this function operates, all the lamps except for the pre-heat lamp turn off. To cancel the auto power shut off state, press the START key.	30 min
Stream feeding mode (with SPF/R-SPF installed)	After making copy with SPF/R-SPF, the document feed display lamp blinks, set the document, and the document is automatically fed.	Cancel
Auto power shut off setting	The auto power shut off function can be canceled.	Setting
2 in 1/4 in 1 solid line frame setting (with electronic sort board, SPF/R-SPF installed)	Images on two or more pages are copied on one sheet of paper (2 in 1/4 in 1). When this function is used, copying can be made with the solid lines at the boundaries of images.	Setting
Rotation copy (With electronic sort board installed)	When the paper auto selection function is operating, if there is no paper of the suitable size or the suitable direction, paper of the same size but of different direction is automatically selected and the document images are rotated by 90 degrees to copy. The magnification ratio auto select function operates and rotates document images by 90 degrees to make proper copy when the document images and the paper direction differ from each other.	Cancel
Paper auto selection	The paper of the same size as the document size selected by the document size set key (A3, B4, A4, A4R, B5, B5R 11" × 17", 8.5" × 14", 8.5" × 13", 8.5" × 11", 8.5" × 11"R, 8.5" × 5.5" only) is automatically selected. This function is canceled.	Setting
Tray auto selection (with 1-step paper feed unit, 2-step paper feed unit installed)	The paper of the same size as the document size selected by the document size set key (A3, B4, A4, A4R, B5, B5R 11" × 17", 8.5" × 14", 8.5" × 13", 8.5" × 11", 8.5" × 11"R, 8.5" × 5.5" only) is automatically selected. This function is canceled.	Setting
Department counter	Refer to "3. Department counter setting."	
Edge erase (with electronic sort board installed)	Shades around images and shades at the binding margin can be erased by this function. The erase range can be set in the range of 0 ~ 20mm by the unit of 5mm.	10mm
2 in 1 layout (with electronic sort board, SPF/R-SPF installed)	The layout pattern for copying images of two pages on one page can be selected. 	Pattern A
4 in 1 layout (with electronic sort board, SPF/R-SPF installed)	The layout pattern for copying images of four pages on one page can be selected. 	Pattern A

\*1: The power consumption in pre-heat, auto power shut off depends on the operating conditions.

## 2. Setting change procedure

Example: Changing the time for operating the auto clear function (from 60 sec to 120 sec)

- Press and hold the density adjustment key  for 5 sec to start setting.
  - When      lamps start blinking at the same time, the copy quantity display shows "--" the digit of 10 blinking.
- Select the function code with the numeric key.
  - The code of the selected function is displayed (blinking) on the digits of 10 and 100.
  - For auto clear, select 1.
  - Select the suitable code according to the table below.

### User program setting contents

Function	Function code	Setting code
Auto clear	1	0 (Cancel)
		1 (30 sec)
		*2 (60 sec)
		3 (90 sec)
		4 (120 sec)
Pre-heat	2	0 (Cancel)
		1 (30 sec)
		2 (60 sec)
		*3 (90 sec)
		4 (120 sec)
Auto power shut off passing time (*2)	3	*1 (30 sec)
		2 (60 sec)
		3 (90 sec)
		4 (120 sec)
		5 (240 sec)
Stream feeding mode	4	*0 (Cancel)
		1 (Setting)
Auto power shut off function setting (*2)	5	0 (Cancel)
		*1 (Setting)
2 in 1/4 in 1 solid frame setting	6	*0 (Cancel)
		1 (Setting)
Rotation copy	7	0 (Cancel)
		*1 (Setting)
Paper auto selection	8	0 (Cancel)
		*1 (Setting)
Tray auto selection	9	0 (Cancel)
		*1 (Setting)
Department counter (*1)	10 ~ 15	
Edge erase	16	0 (0mm)
		1 (5mm)
		*2 (10mm)
		3 (15mm)
		4 (20mm)
2 in 1 layout (*3)	17	*1 (Pattern A)
		2 (Pattern B)
4 in 1 layout (*3)	18	*1 (Pattern A)
		2 (Pattern B)
		3 (Pattern B)
		4 (Pattern B)

\* Setting at the factory shipping

- For the setting procedure, refer to "3. Department counter."
- With the auto power shut off canceled (function code "5", set code "0", auto power shut off time setting code "3"), the mode enters the auto power shut off setting mode automatically.

\*3. For the layout pattern, refer to page 9-1.

- The number of the selected function blinks on the digit of 1 or the copy quantity display.





Cancel: When any key is pressed by mistake, press the clear key and press the proper key.

- Press the START key.
  - The selected function code is changed from blinking to lighting.
  - The currently set code blinks on the digit of 1.
- Select the setting code with the numeric key.
  - For setting to 80 sec, select [3].
  - Make setting referring to the setting codes of "User program setting contents."

Cancel: When any wrong key is pressed, press the clear key and resume from procedure 2.

- Press the START key,
  - The selected setting code is changed from blinking to lighting. The setting is completed with the above operation.

Memo: To set another function, press the clear key after this procedure and resume from procedure 2.





- Press the density adjustment key  to end the setting.
  -     lamps go off. The copy quantity display returns to the normal display.

## 3. Department counter setting

Note: The department counter is effective only in copying. Counting is not made in FAX and printer output.

When the department counter is set, the copy count for each department (max. 20 dept.) can be made and displayed when necessary.

With the department counter set, copying cannot be made unless the registered number (password number of 3 digits) is entered.





- Press and hold the density adjustment key  for about 5 sec to start setting.
  -    lamps start blinking at the same time, and the copy quantity display displays "--" and the digit of 10 blinks.
- Select the function code with the numeric key.
  - Refer to the function code for setting.

### Setting contents of department counters

Function	Function code	
Setting content	10	Department counter setting or cancel. Factory setting: Cancel
Department counter setting/cancel	11	Department number recording. Max. 20 department can be recorded.
Department number recording	12	Recorded department number is changed.
Department number delete	13	Recorded number is deleted.
Copy quantity display (Total)	14	The copy quantity in each department is displayed. The count is made up to 49,999 sheets. From that, counting is started from 0.
Copy quantity delete (Total delete)	15	The counted copy quantity is canceled. The count of each department or that of all the departments can be deleted.

- The entered number blinks on the digits of 100 and 10 on the copy quantity display.

Cancel: When a wrong key is pressed, press the clear key and enter the correct key.

- 3) Press the START key.
- The selected function code is changed from blinking to lighting.
  - The currently set code blinks on the digit of 1.
- Cancel: When the "E" (error code) is lighted on the digit of 1, press the clear key and return to procedure 2.
- 4) Perform setting of the department counter.  
Perform setting referring to "F.Copy quantity delete" in "A. Department counter setting/cancel."
- 5) Press the density adjustment key  to end the setting procedure.
-     lamps go off.
  - The copy quantity display returns to the normal display.

### A. Department counter setting/cancel (Function code: 0)

Used to set or cancel the department counter. When this setting is made, the copy quantity display lights up with "--."

Under this state, the department number in 3 digits must be entered to operate the machine.

After entering the function code "0," use the numeric key to set or cancel the department counter.

- 1) To set the department counter, select "1." To cancel, select "0." Then press the START key.

Memo: After this setting, use the "Department number recording" to record the department number of each department.  
(Max. 20 departments can be recorded.)

- 2) Press the clear key.

### B. Department number recording (Function code: 11)

Used to record the department number.

When the function code "1" is entered, the copy quantity display blinks with "--."

When the recorded department number reaches 20, the error code of "11E" is displayed.

- 1) Use the numeric key to enter the number of 3 digits (except for 000) and press the START key.
- When the recorded number or "000" is entered, the entered number blinks. In this case, enter another number.
  - To register another department number, repeat the same procedure 1) above.
- 2) After completion of recording, press the clear key.
- The registered department number and each department name must be recorded. (Since the department name cannot be registered, they must be recorded for total calculation.)

### C. Department number change (Function code: 12)

Used to change the department number.

Enter the function code "12" and select the department number to be registered.

If there is no registered department number, the error code of "12E" is displayed.

- 1) Select the department number with % key, and press the START key.
- The copy quantity display shows "- - - - ."
- 2) Use the numeric key to enter a new department number (3 digits except for 000), and press the START key.
- When the recorded number or "000" is entered, the entered number blinks. In this case, enter another number.
  - To register another department number, repeat the same procedures 1) and 2) above.
- 3) After completion of changing, press the clear key.

### D. Department number delete (Function code 13)

Delete the department number.

Enter the department code (13) and select all departments clear or specified department clear.

When there is no registered department number, the error code "13E" is displayed.

#### (1) All departments clear

- 1) Press "1" key.  
2) Press the START key.

#### (2) Specified department clear

- 1) Press "0" key.  
2) Select the department number to be deleted with % key.  
3) Press the START key.

### E. Copy quantity display (sum total) (Function code: 14)

The copy quantity of each department is displayed.

Enter the function code "14" and select the department number of which the total copy quantity is to be displayed.

If there is no registered department number, the error code "14E" is displayed.

- 1) Select the department number with % key.  
2) Press and hold "0" key, and the copy quantity will be displayed.

- The copy quantity is displayed in two steps.

(Example) Copy quantity: 12, 345

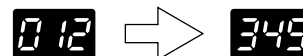

- To display the copy quantity of another department, repeat the same procedure 1) and 2).
- 3) Press the clear key to terminate the procedure.

### F. Copy quantity clear (total clear) (Function code: 15)

The copy quantity of each department is cleared.

After entering the function code "15", select all department clear or specified department clear.

If there is no registered department, the error code "15E" is displayed.

#### (1) All department total clear

- 1) Press "1" key.  
2) Press the START key.

#### (2) Specified department clear

- 1) Press "0" key.  
2) Select the department number with % key.  
3) Press the START key.

**[10] TROUBLE CODE LIST**

Classification	Function	Main code	Sub code	Trouble name	Remark
Electrical system error	Copier	H2	00	Thermistor open error	Thermistor is open
		H3	00	Fusing temperature abnormality (Abnormally high temperature detection)	Abnormally high fusing temperature
		H4	00	Fusing temperature abnormality (Abnormally low temperature detection)	Abnormally low fusing temperature
		CC		Media sensor error	Document detection error
		U2	04	EEPROM communication error	EEPROM abnormality
			11	Counter SAM error	EEPROM counter area SAM abnormality
			12	Adjustment value SAM error	EEPROM adjustment value memory area SAM abnormality
	F5	02	Copy lamp error	Copy lamp disconnection	
	FAX	F6	00	FAX board communication trouble	
			10	FAX board trouble	
			80	FAX board communication trouble (Protocol)	
			81	FAX board communication trouble (Parity)	
			82	FAX board communication trouble (Overrun)	
			84	FAX board communication trouble (Framing)	
			88	FAX board communication trouble (Timeout)	
	Printer	F9	00	Printer board communication trouble	
			10	Printer board trouble	
			80	Printer board communication trouble (Protocol)	
			81	Printer board communication trouble (Parity)	
			82	Printer board communication trouble (Overrun)	
			84	Printer board communication trouble (Framing)	
			88	Printer board communication trouble (Timeout)	
	Electronic sort	E1	00	Electronic sort board communication trouble	
			10	Electronic sort board trouble	
			11	ASIC error	ASIC abnormality
			12	Image compression error	JBIG IC abnormality
			13	Flash ROM error	Program ROM abnormality
			14	RAM error	Work RAM abnormality
			15	Page memory error	Print buffer abnormality
			16	SIMM error	Compression storing memory abnormality
			17	Image rotating RAM error	Rotating RAM abnormality
			80	Electronic sort board communication trouble (Protocol)	
			81	Electronic sort board communication trouble (Parity)	
82			Electronic sort board communication trouble (Overrun)		
84			Electronic sort board communication trouble (Framing)		
88	Electronic sort board communication trouble (Timeout)				



Classification	Function	Main code	Sub code	Trouble name	Remark	
Electrical system error	Operation	U9	00	Operation board communication trouble		
			80	Operation board communication trouble (Protocol)		
			81	Operation board communication trouble (Parity)		
			82	Operation board communication trouble (Overrun)		
			84	Operation board communication trouble (Framing)		
			88	Operation board communication trouble (Timeout)		
	Zero cross	L8	01	Zero cross trouble		
Optical system error	CCD	E7	04	CCD white level trouble	CCD white level abnormality	
			05	CCD black level trouble	CCD black level abnormality	
			12	Shading trouble	White correction is not completed with the specified number of operations	
	LSU	E7	03	LSU trouble	LSU abnormality	
Mechanical system error	Mirror motor	U3	29	Mirror home position error		
			L1	00	Mirror feed trouble	
			L3	00	Mirror return trouble	
	Main motor	L4	01	Main motor lock		
	LSU	L6	10	Polygon motor trouble		
	Shifter	F1	06	Shifter motor trouble		
	Job separator	L4	10	Job separator motor trouble	Job separator function	
Others	Operation	U95		Operation connection abnormality	Panel individual display caused by abnormal panel connection	

# [11] MAINTENANCE

## 1. Maintenance table

X: Check (Clean, adjust, or replace when required.) ○: Clean ▲: Replace △: Adjust ☆: Lubricate

Unit name	Part name	When calling or replacing the kit	150k	
Transfer section	Charger unit	○	○	
	Transfer paper guide	○	○	
Optical section	Lamp unit	Reflector	○	
		Mirror	○	
	No. 2/3 mirror unit	Mirror	○	
		Pulley	X	X
	CCD peripheral	Lens	○	○
	Glass	Table glass	○	○
		White plate	○	○
	Other	Drive wire	X	X
		Rail	X☆	X☆
		Document cover	○	○
Document size sensor		○	○	
LSU	Dust-proof glass	○	○	
Paper feed section	Multi paper feed section	Takeup roller	○	○
		Paper feed roller	○	○
		Spring clutch	○☆	○☆
	Cassette section	Paper feed roller	○	○
		Spring clutch	○☆	○☆
Paper transport section	PS roller	○	○	
	Transport (paper exit) rollers	○	○	
	Spring clutch	○☆	○☆	
Fusing section	Upper heat roller	○	▲	
	Pressure roller	○	○	
	Pressure roller bearing	X	○☆	
	Upper separation pawl	X	○	
	Lower separation pawl	X	○	
Drive section	Gears	X☆	X☆	
	Belts	X	○	

## [12] DISASSEMBLY AND ASSEMBLY

**WARNING:** Before performing the disassembly procedure, be sure to remove the power cord to prevent against an electric shock.

No.	Item	Page
1	High voltage section	12-1
2	Optical section	12-1
3	Fusing section	12-2
4	Paper exit section	12-4
5	MCU	12-6
6	Optical frame unit	12-6
7	LSU	12-6
8	Tray paper feed section/Paper transport section	12-7
9	Manual multi paper feed section	12-8
10	Power section	12-10
11	Developing section	12-11
12	Process section	12-12

### 1. High voltage section

No.	Content
A	Transfer charger unit
B	Charger wire

#### A. Transfer charger unit

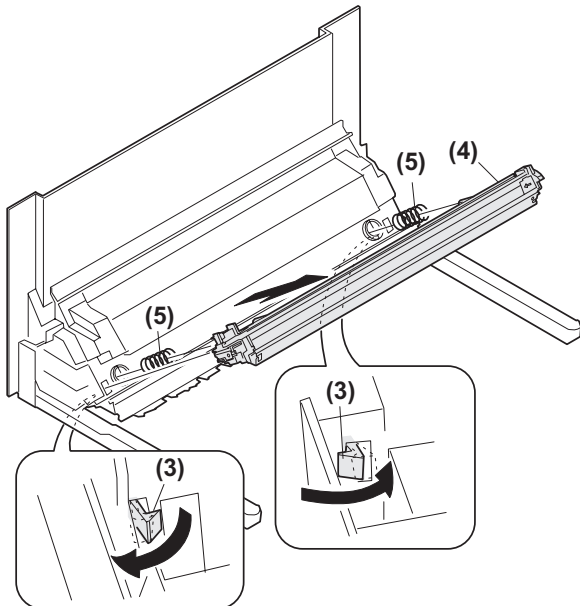
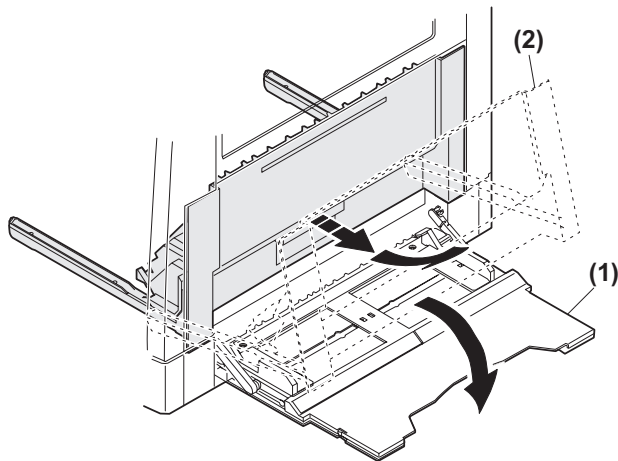

#### B. Charger wire

Installation: The spring tip must be between two reference ribs.

- The charger wire must be free from twist or bending.
- Be sure to put the charger wire in the V groove.

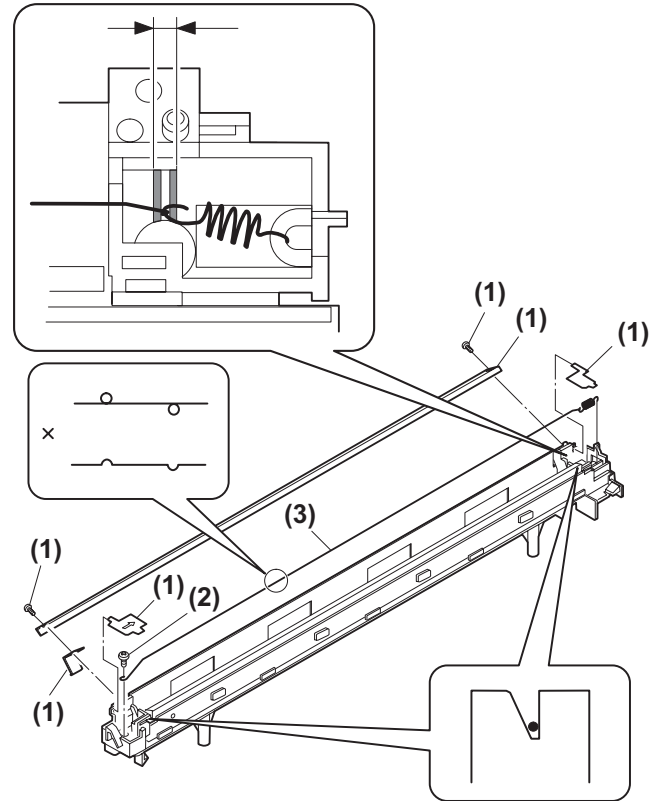

### 2. Optical section

No.	Content
A	Table glass
B	Copy lamp unit
C	Copy lamp
D	Lens unit

#### A. Table glass

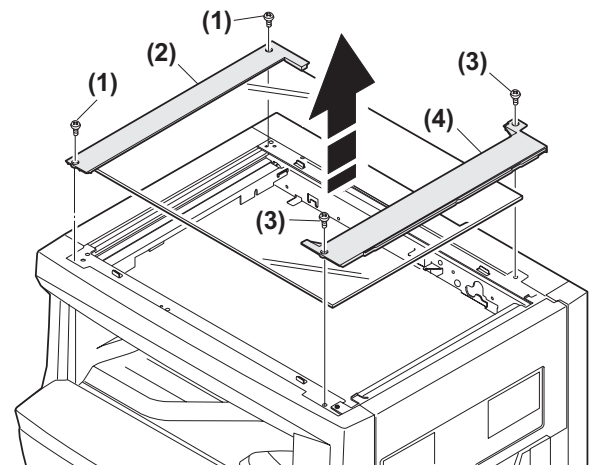

### B. Copy lamp unit

Disassembly: Be sure to put No. 2/3 mirror unit to the positioning plate (A).

Assembly: Put the notched surface of wire holder (3) downward, tighten temporarily, and install.

Adjustment: Main scanning direction distortion balance adjustment

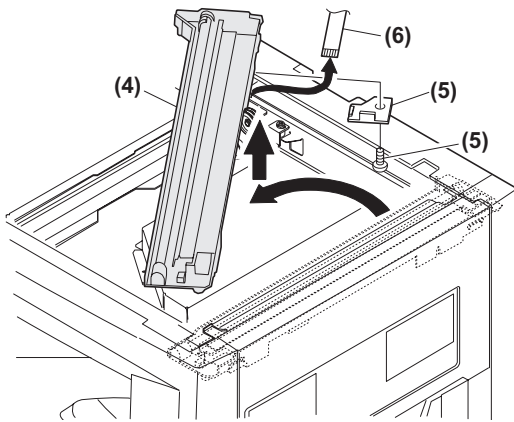
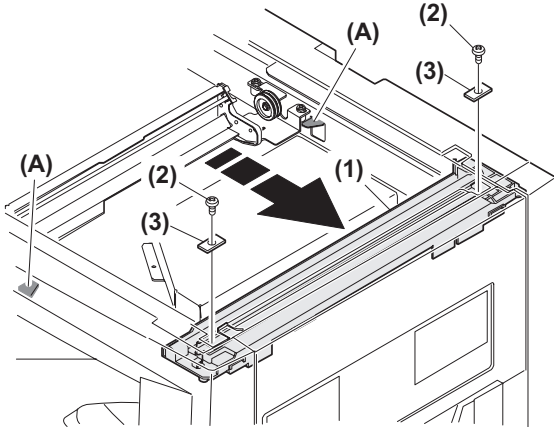
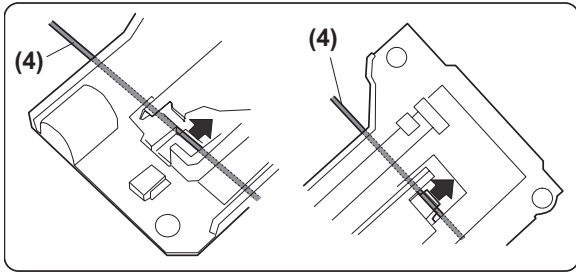

### C. Copy lamp

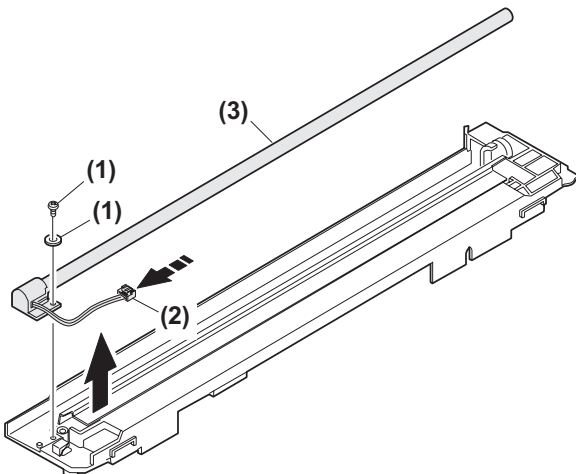

### D. Lens unit

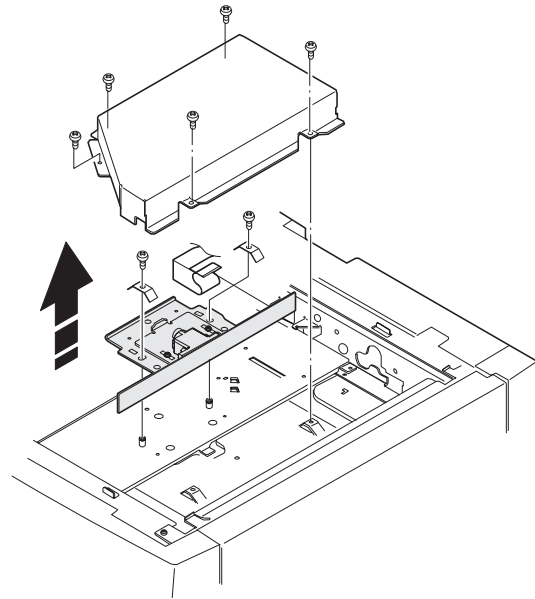

### 3. Fusing section

No.	Contents
A	Fusing unit
B	Thermostat
C	Thermistor
D	Heater lamp
E	Upper heat roller
F	Separation pawl
G	Lower heat roller

#### A. Fusing unit removal

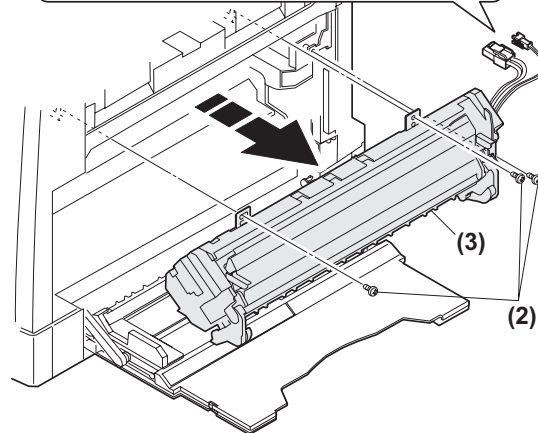
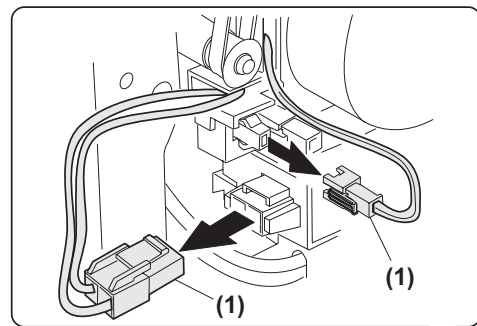

## B. Thermostat

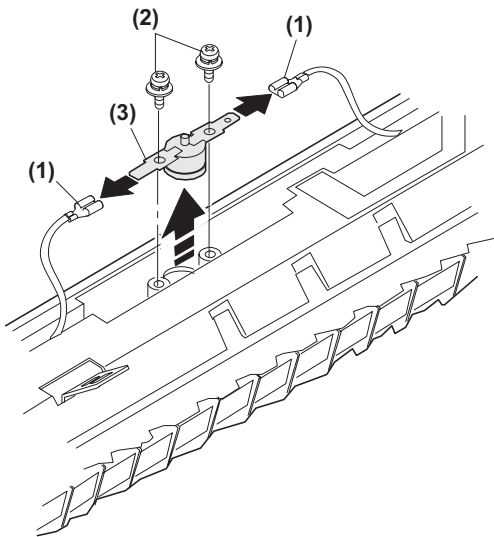

## C. Thermistor

Installation: Check that the thermistor is in contact with the upper heat roller.

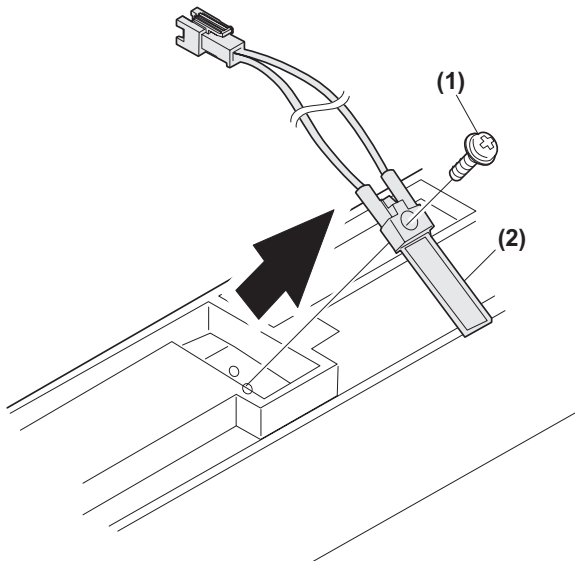

## D. Heater lamp

Assembly: Insert the spring (A) into the hole (B) in the fusing frame.

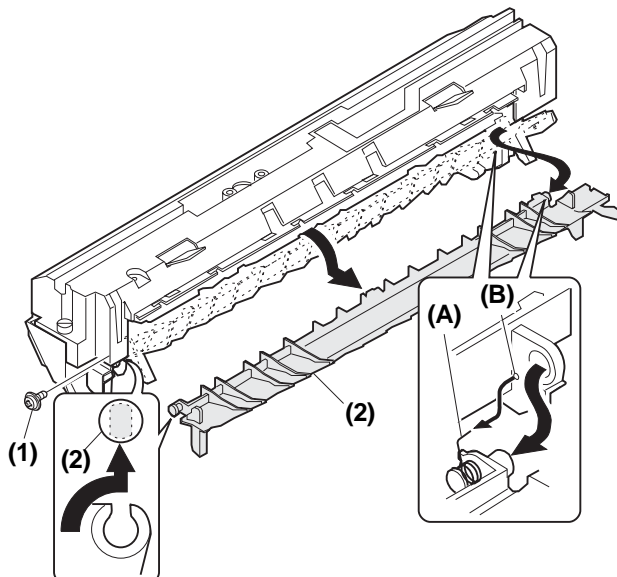

Assembly: Put the paper guide earth spring (A) under the paper guide (B) before fusing.

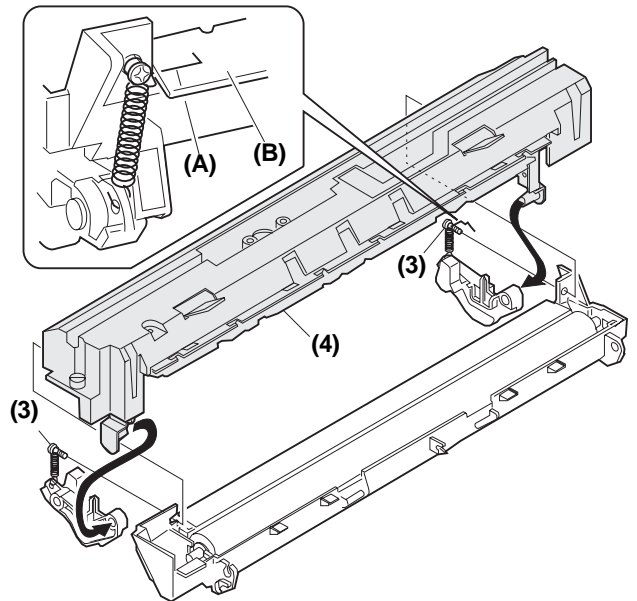

Disassembly: There are three pawls on the fusing cover. Remove the screws and slide the fusing cover to the right to remove.

The heater lamp is fixed on the fusing cover with a screw. Slide the fusing cover to the front and remove the screw, then remove the heater lamp.

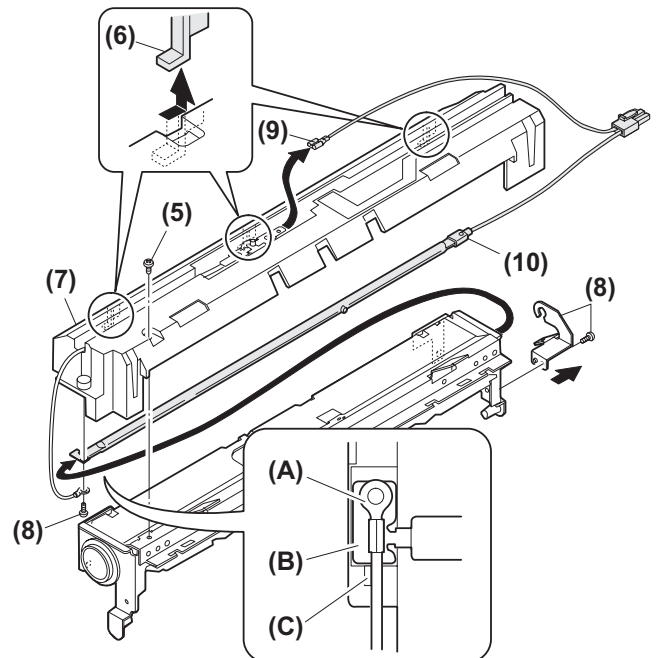

Assembly: Put the fusing harness (A) on the heater lamp (B) as shown in the figure and fix them together. Place the fusing harness inside the rib (C).

**E. Upper heat roller**

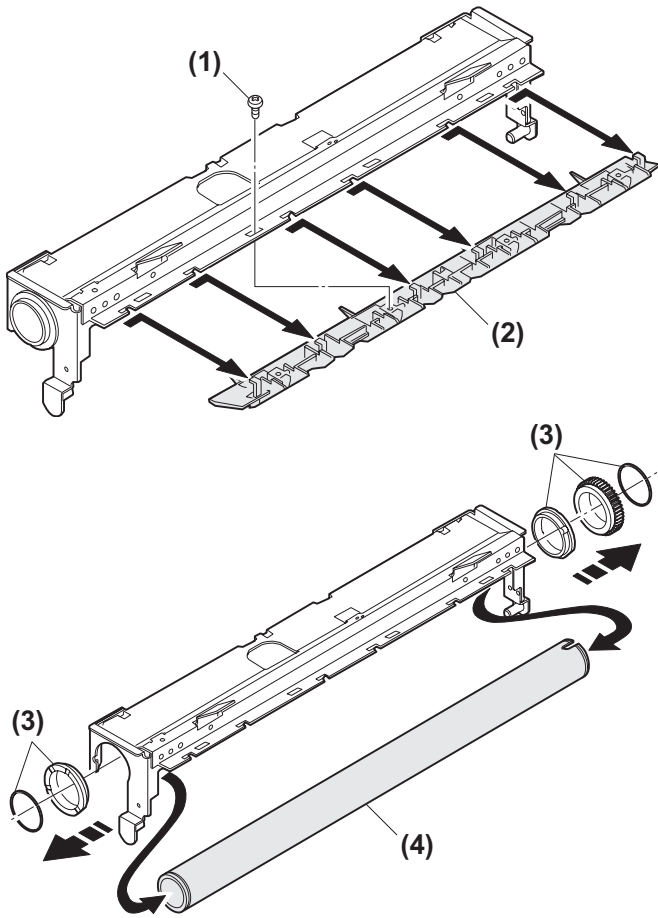

**F. Separation pawl**

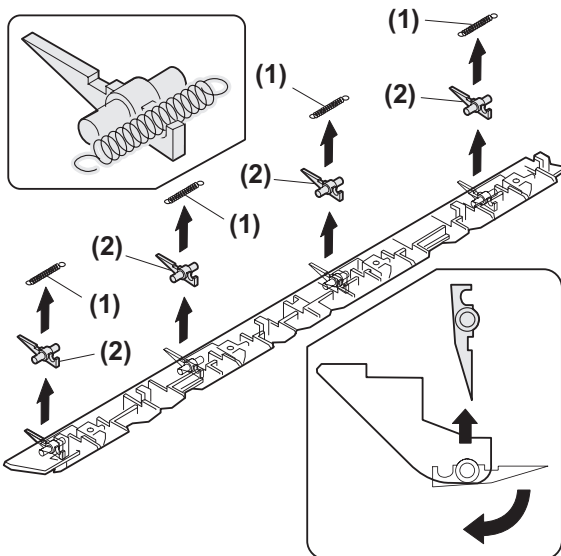

**G. Lower heat roller**

Assembly: When installing the paper guide (3) before fusing, tighten the paper guide fixing plate so that the paper guide fixing plate (2) is in contact with the frame bottom section (A) under fusing.

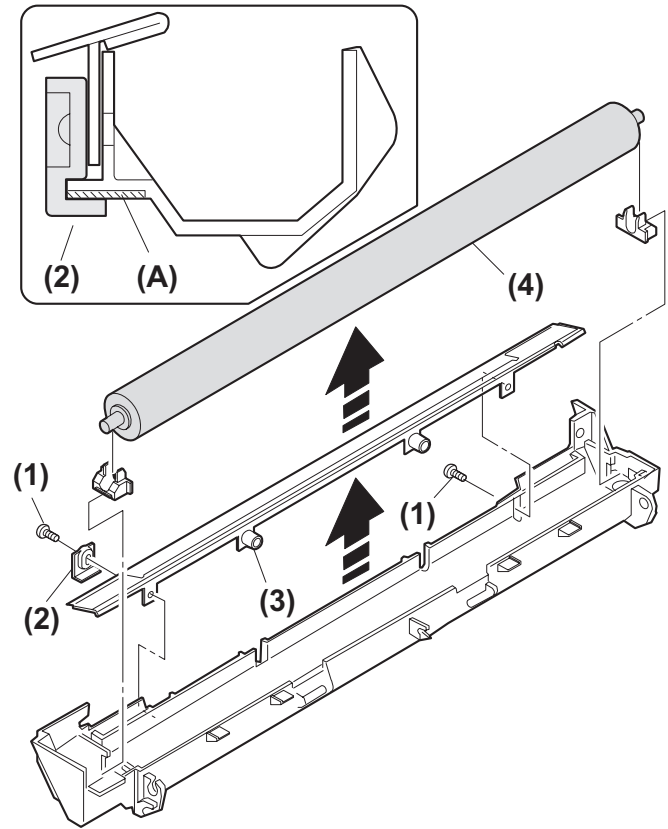

**4. Paper exit section**

No.	Content
A	Front cabinet unit/Right cabinet unit
B	Paper exit unit
C	Transport roller
D	Paper exit roller

**A. Front cabinet unit, right cabinet disassembly**

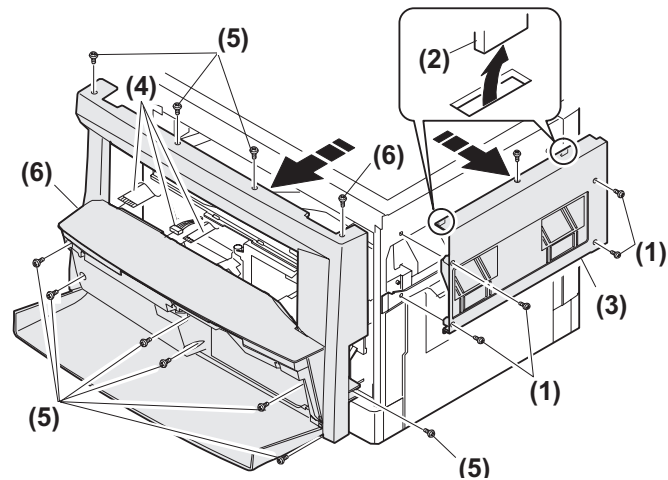

## B. Paper exit unit

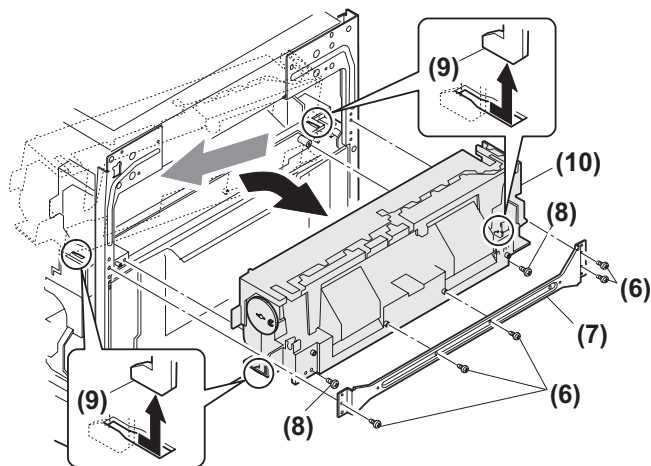
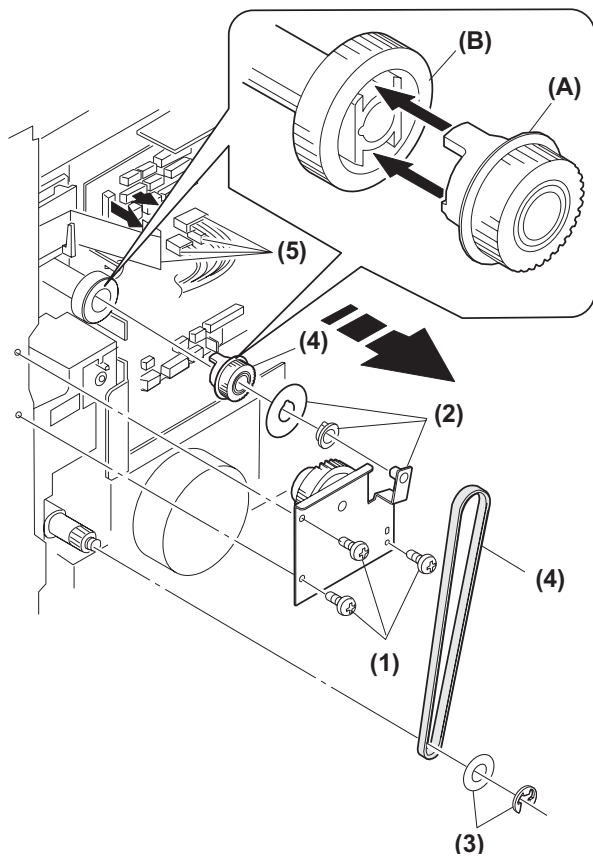

## C. Transport roller

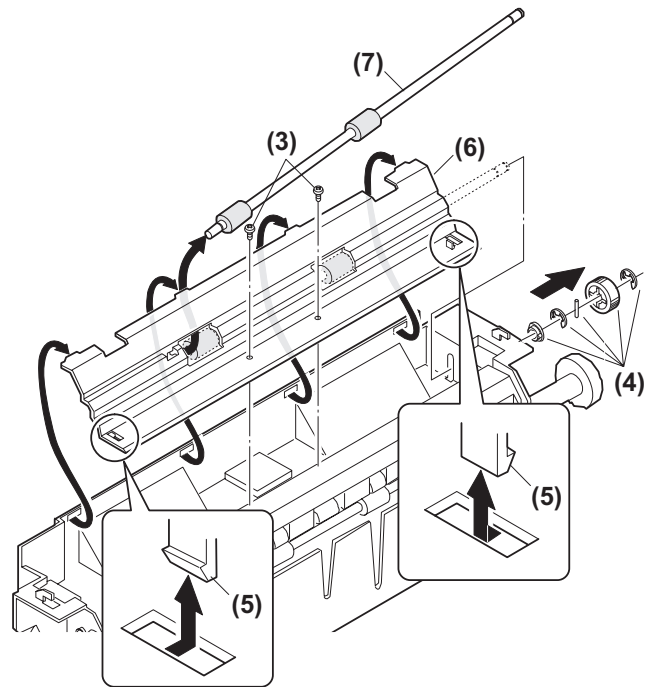
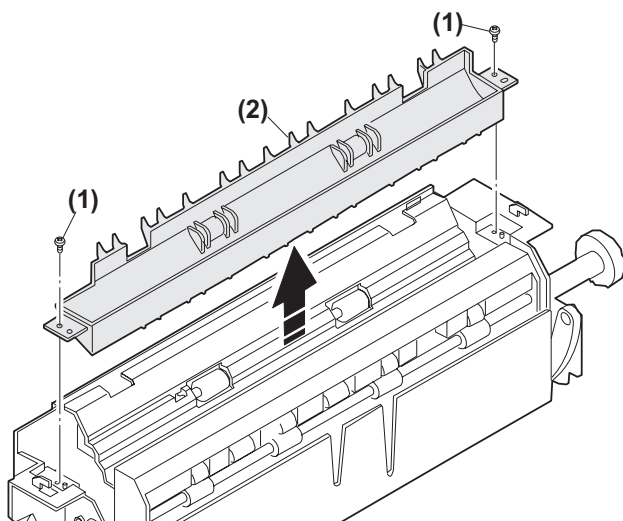

## D. Paper exit roller

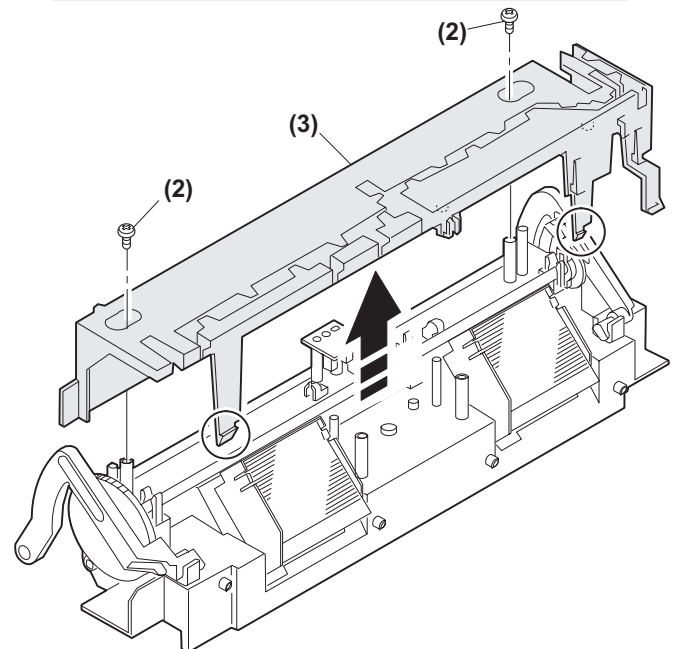
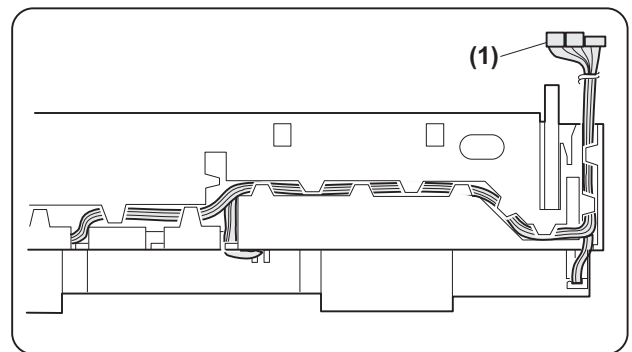

Assembly: Insert the spring pin so that the waveform (A) of the spring pin faces in the longitudinal direction of the paper exit drive gear long hole (B).  
Be sure to insert two ribs (C) into the groove (D).



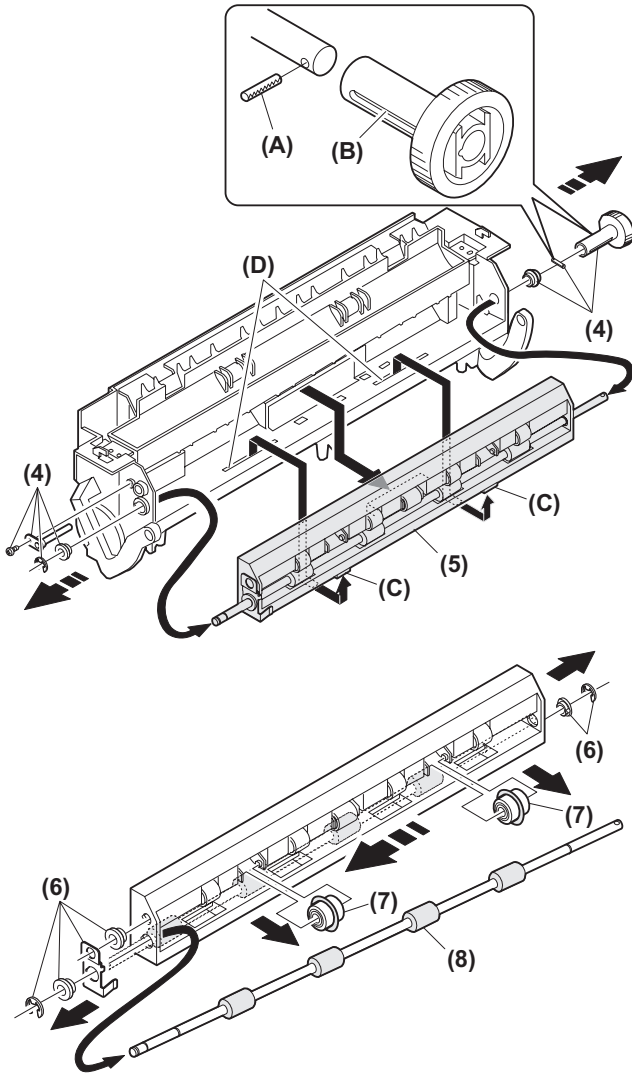

### 5. MCU

No.	Content
A	MCU

#### A. MCU disassembly

Note: When replacing the MCU PWB, be sure to replace the EEPROM of the MCU PWB to be replaced.

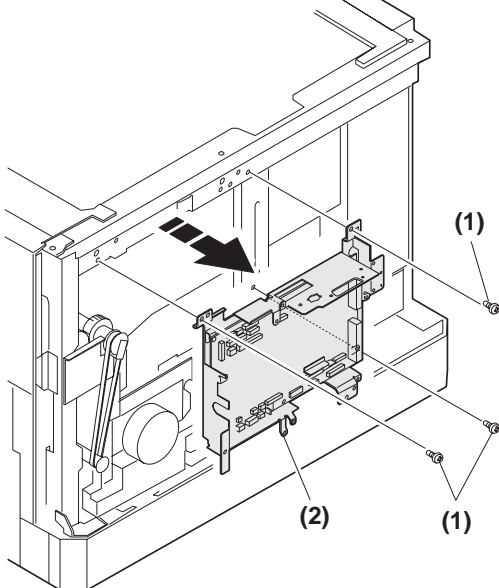

### 6. Optical frame unit

No.	Content
A	Optical frame unit

#### A. Optical frame unit

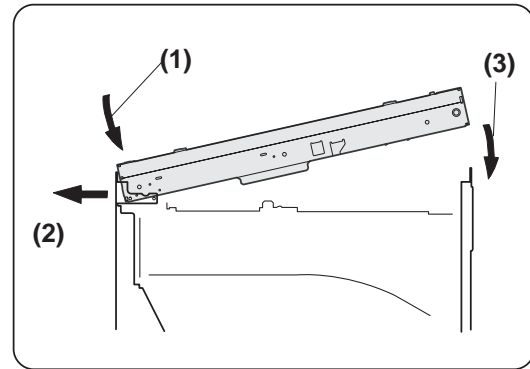
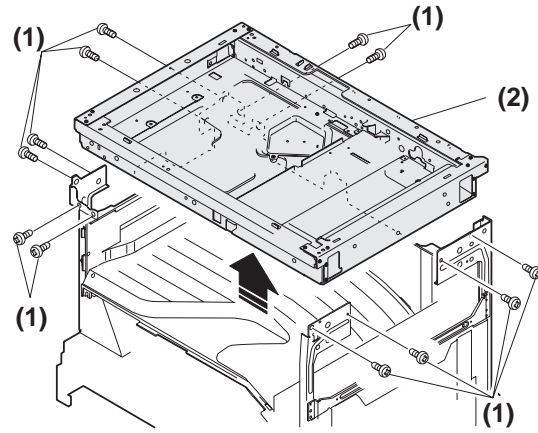

Installation: Install the optical unit in the sequence shown above.

### 7. LSU

No.	Content
A	LSU unit

#### A. LSU unit

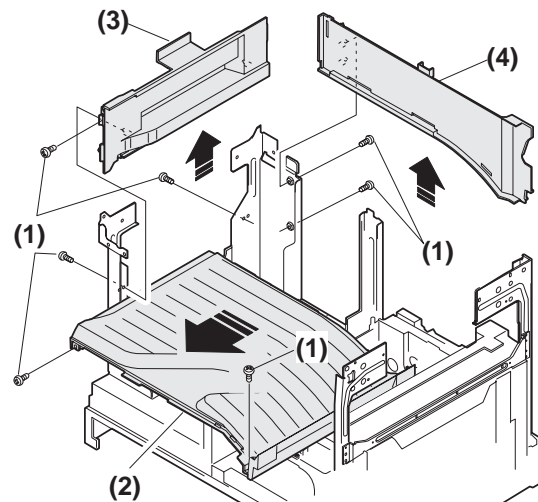



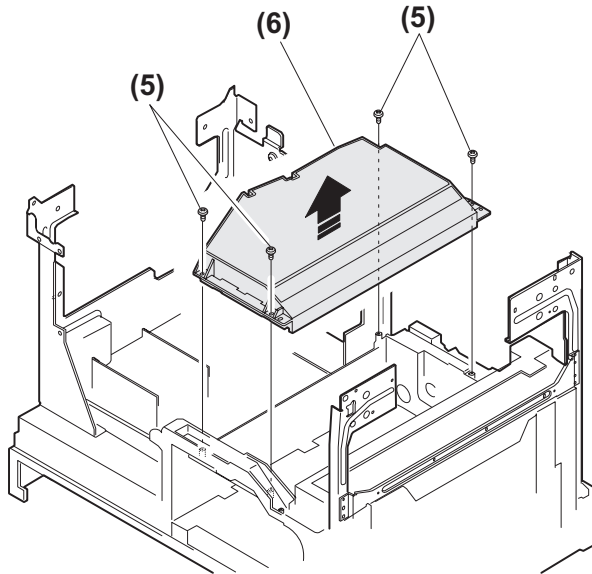

- Adjustment:
- Image lead edge position adjustment
  - Image left edge position adjustment
  - Paper off-center adjustment

### 8. Tray paper feed section/Paper transport section

No.	Content
A	Interface frame unit
B	Drive unit
C	Solenoid (paper feed solenoid, resist roller solenoid)
D	Resist roller clutch , Resist roller
E	Paper feed clutch/Paper feed roller (Semi-circular roller)

#### A. Intermittent frame unit

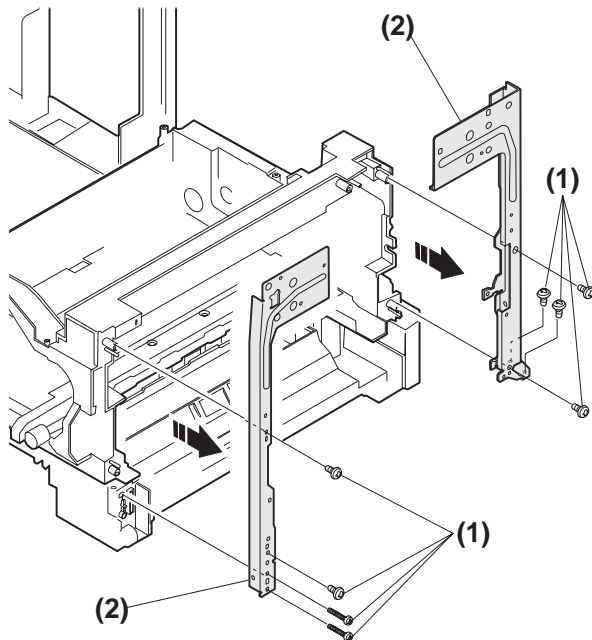

Assembly: Do not miss the door lock pawl.

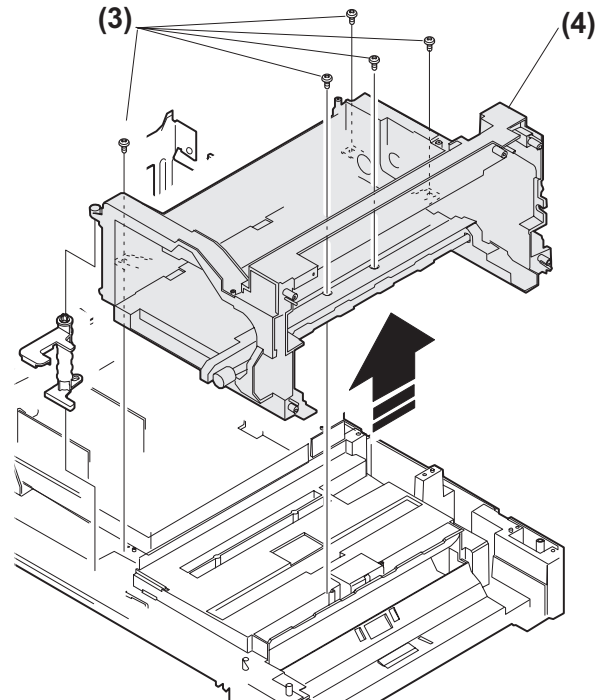

#### B. Drive unit

Assembly: Move down the clutch pawl as shown below, and avoid the clutch and install.

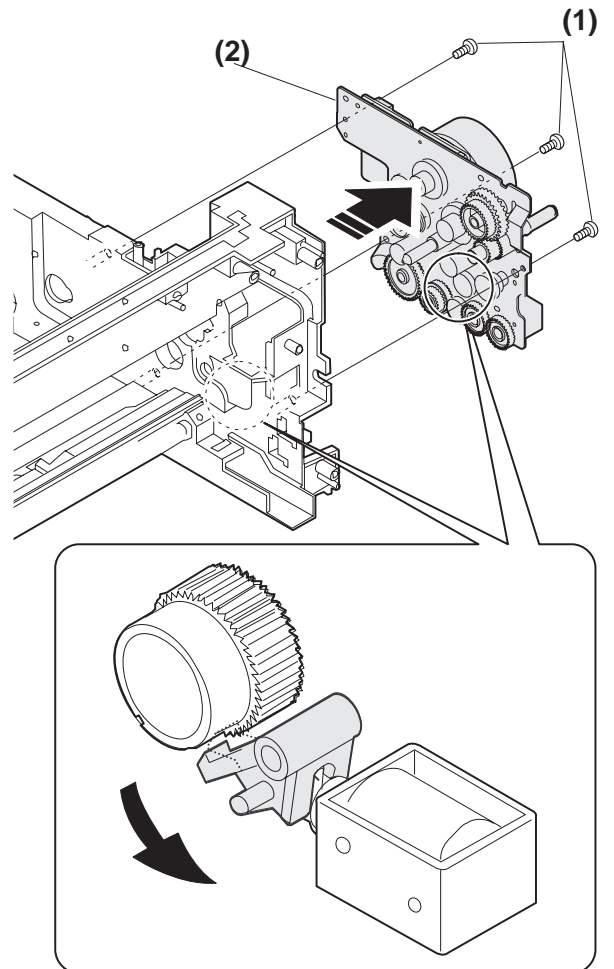

**C. Solenoid (paper feed solenoid, resist roller solenoid)**

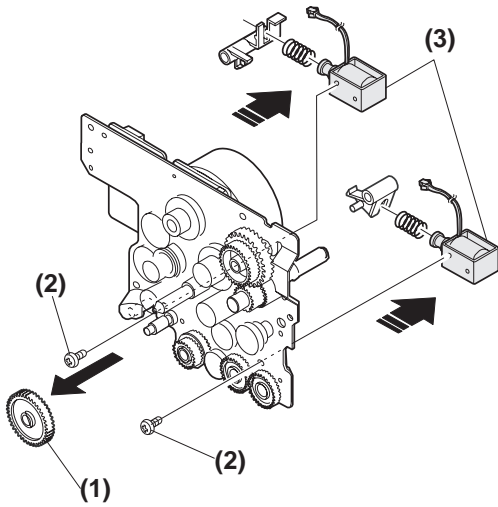

**D. Resist roller clutch/Resist roller**

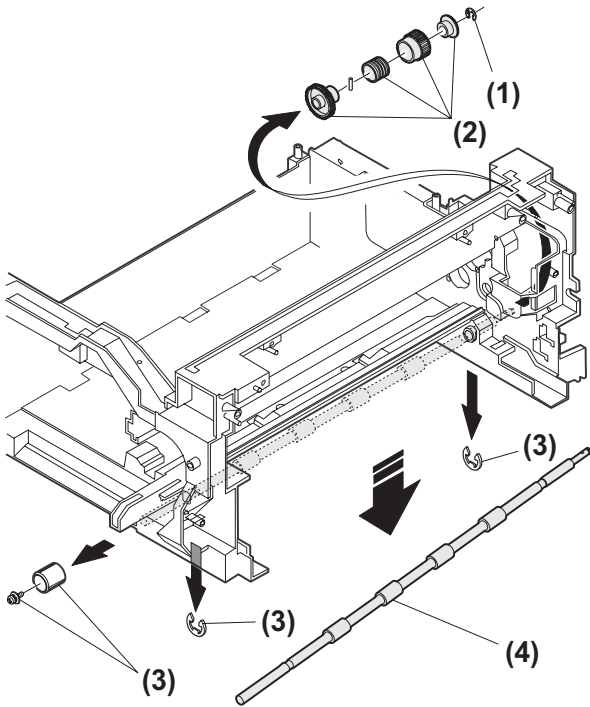

**E. Paper feed clutch/Paper feed roller (Semi-circular roller)**

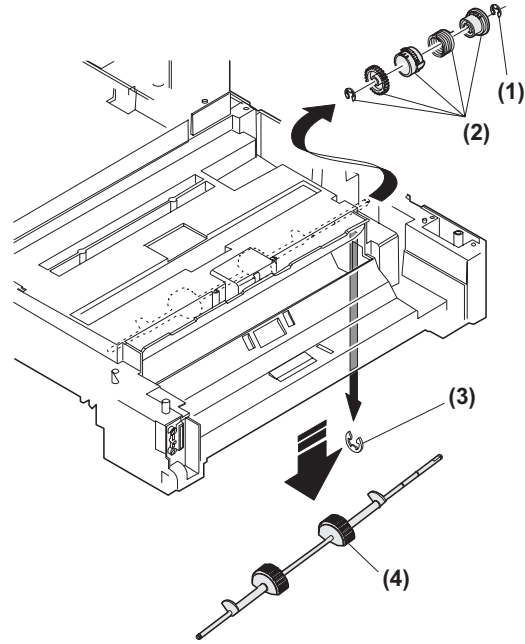

**9. Manual multi paper feed section**

No.	Content
A	Manual multi paper feed section
B	Manual transport clutch
C	Manual paper feed clutch
D	Manual transport roller/Manual paper feed roller
E	Multi feed solenoid

**A. Manual multi paper feed**

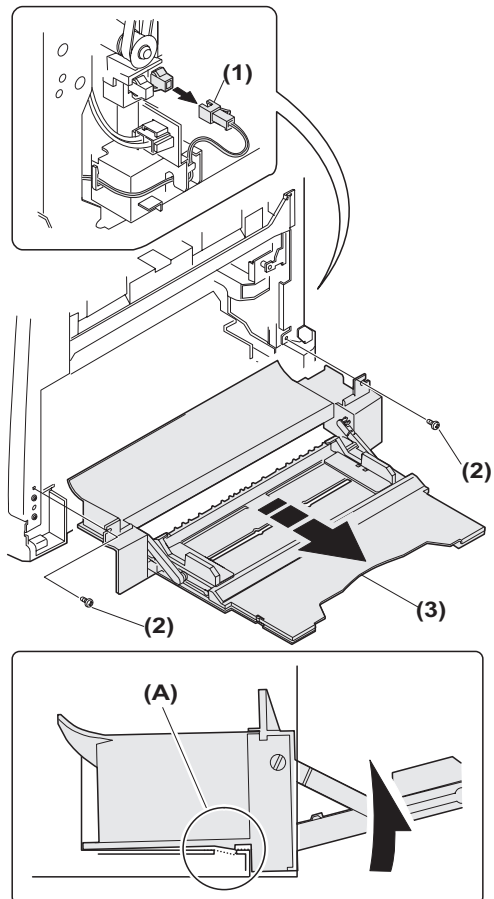

## B. Manual transport clutch

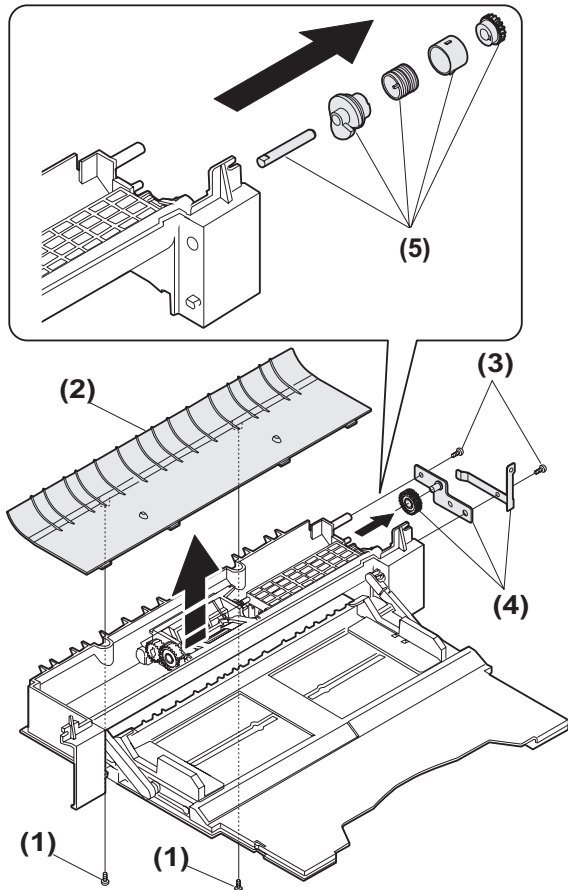

Disassembly: Set up the cam transmission arm (2), and remove it.

Assembly: Install so that the cam transmission arm (2) is under the roller arm (A).

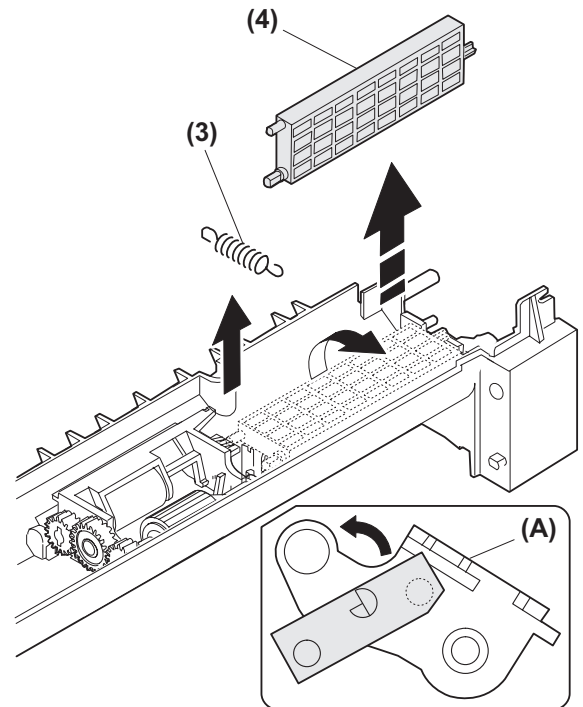

## C. Manual paper feed clutch

Disassembly: Set up the shutter arm (1) then remove it.

Assembly: Install so that the boss section of the fulcrum arm (2) comes between ribs.

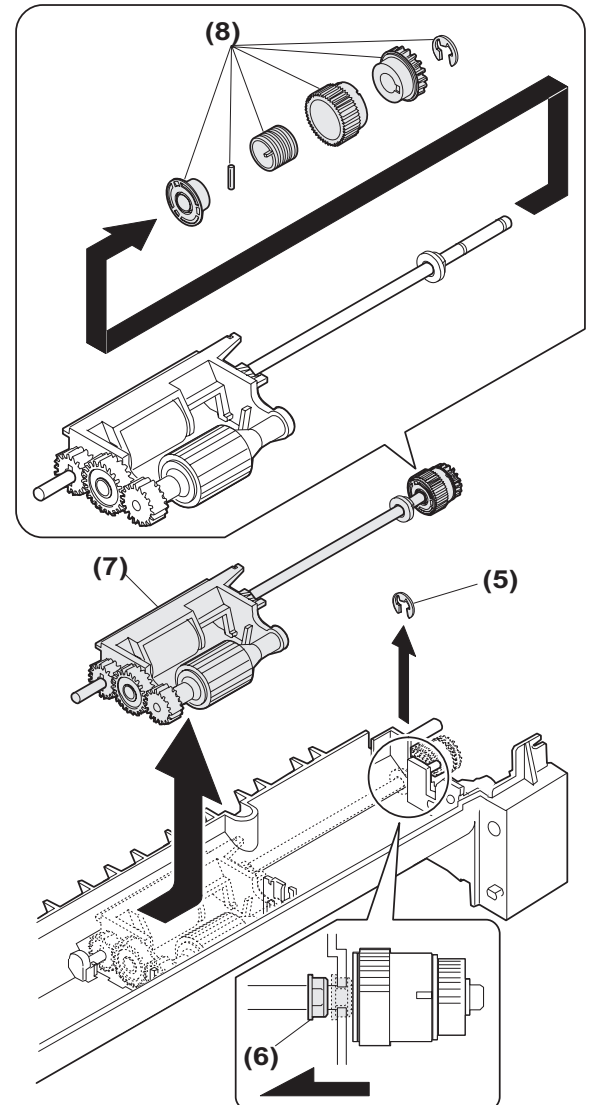
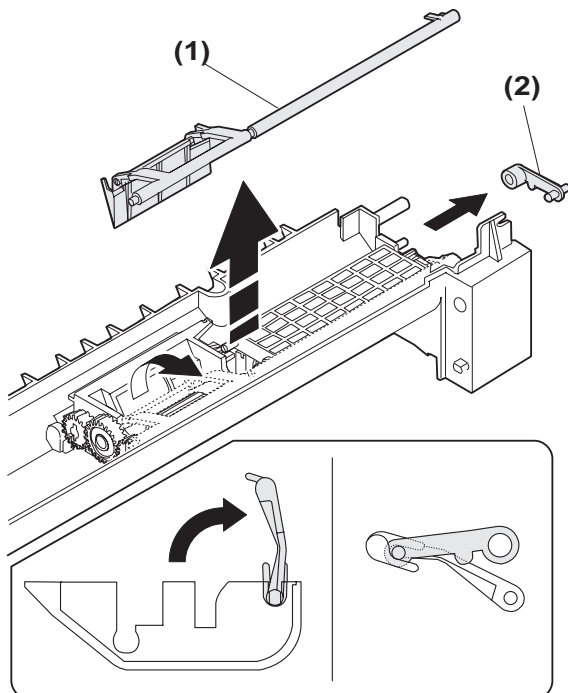

### D. Manual transport roller/Manual paper feed roller

Installation: Be careful of the installing direction of the manual transport roller (4).

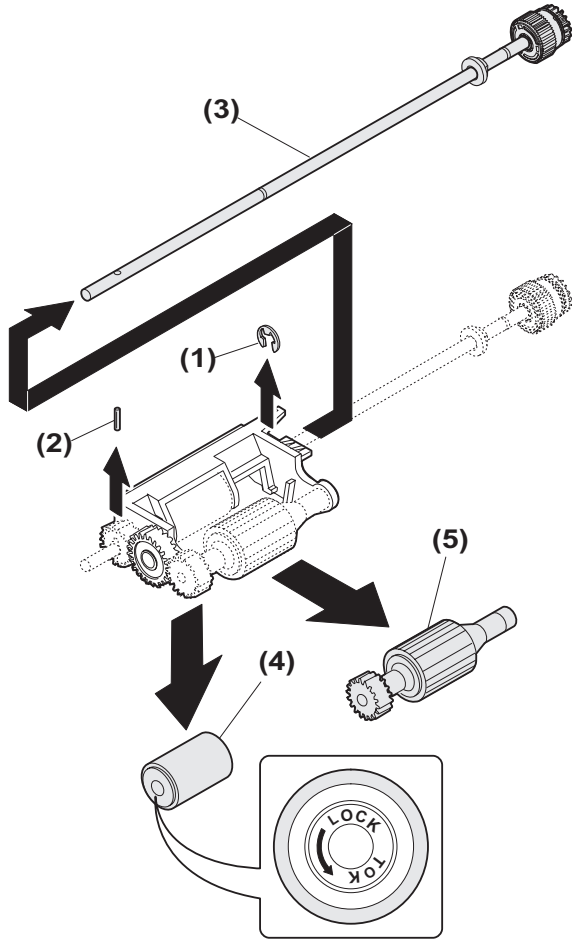

### E. Multi feed solenoid

Assembly: Install so that the latches (A) and (B) move smoothly.

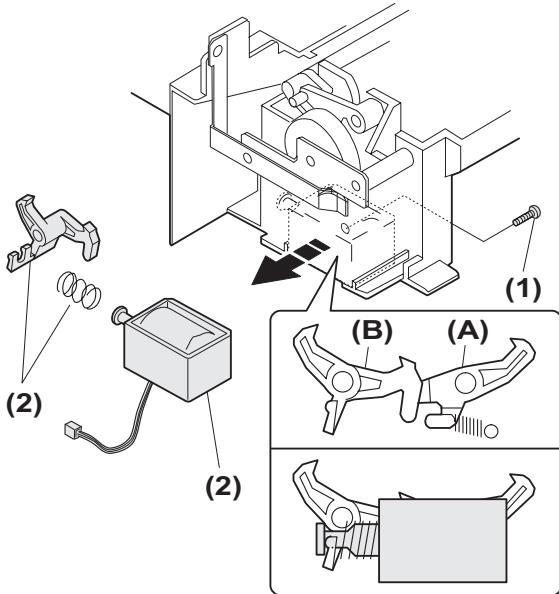

## 10. Power section

No.	Content
A	Power unit

### A. Power unit

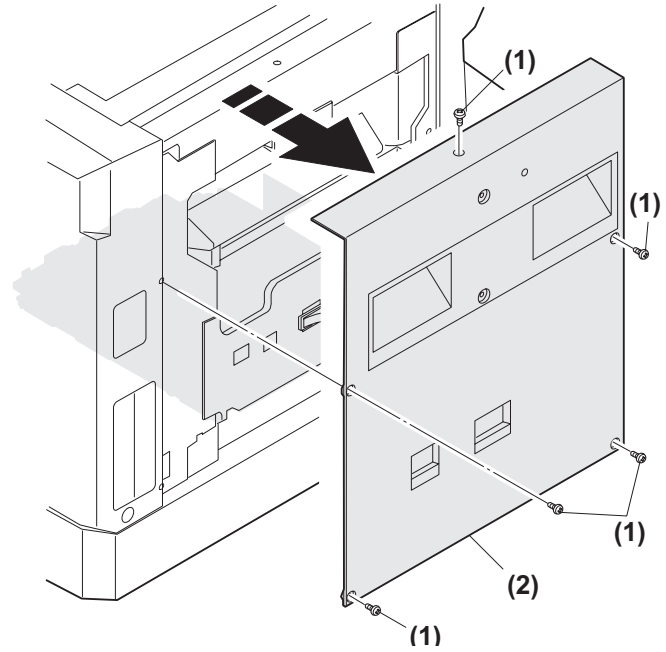
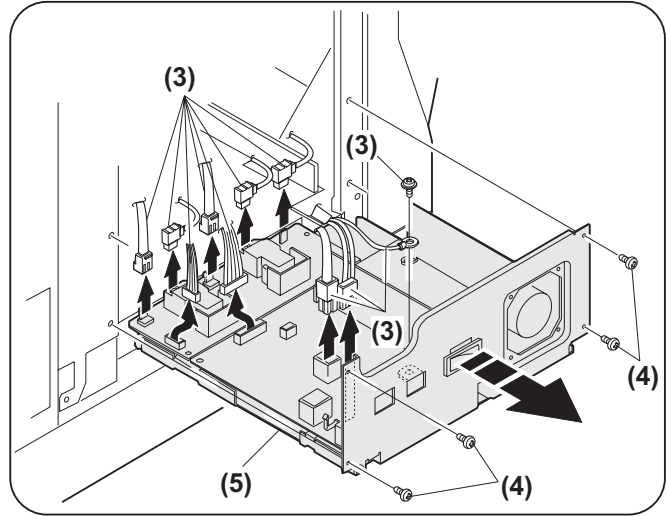

## 11. Developing section

No.	Contents
A	Waste toner box
B	Developing box
C	Developing doctor
D	MG roller

### A. Waste toner box

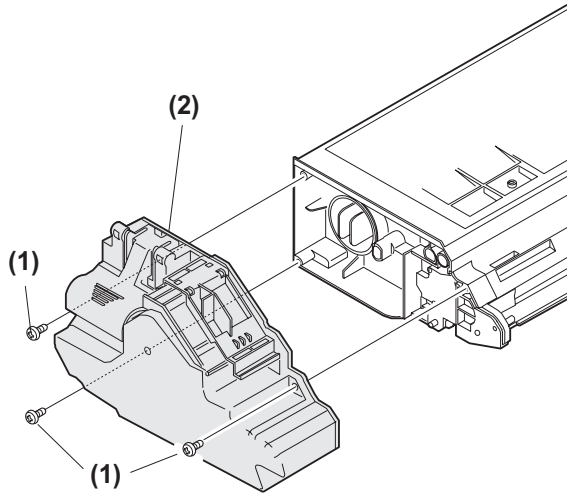

### B. Developing box

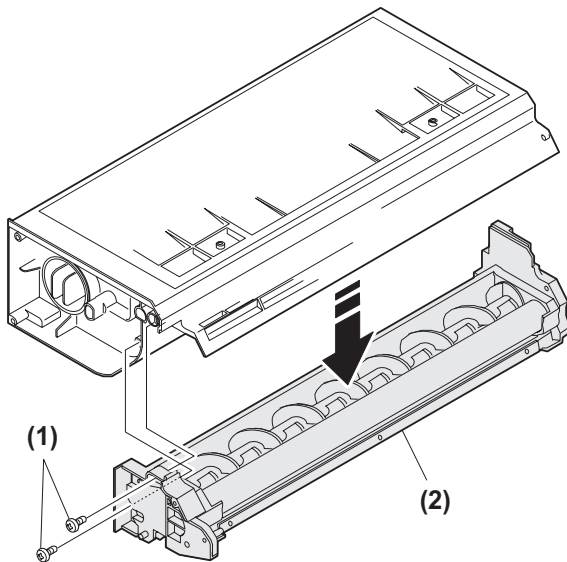

### C. Developing doctor

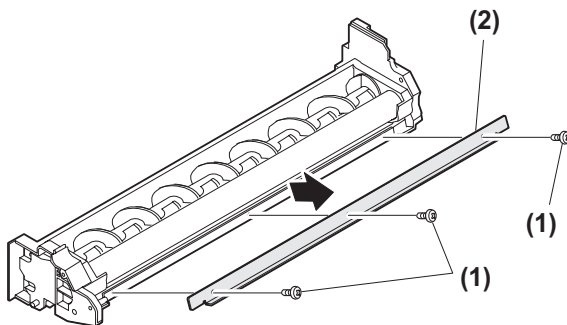

Adjustment: Developing doctor gap adjustment

### D. MG roller

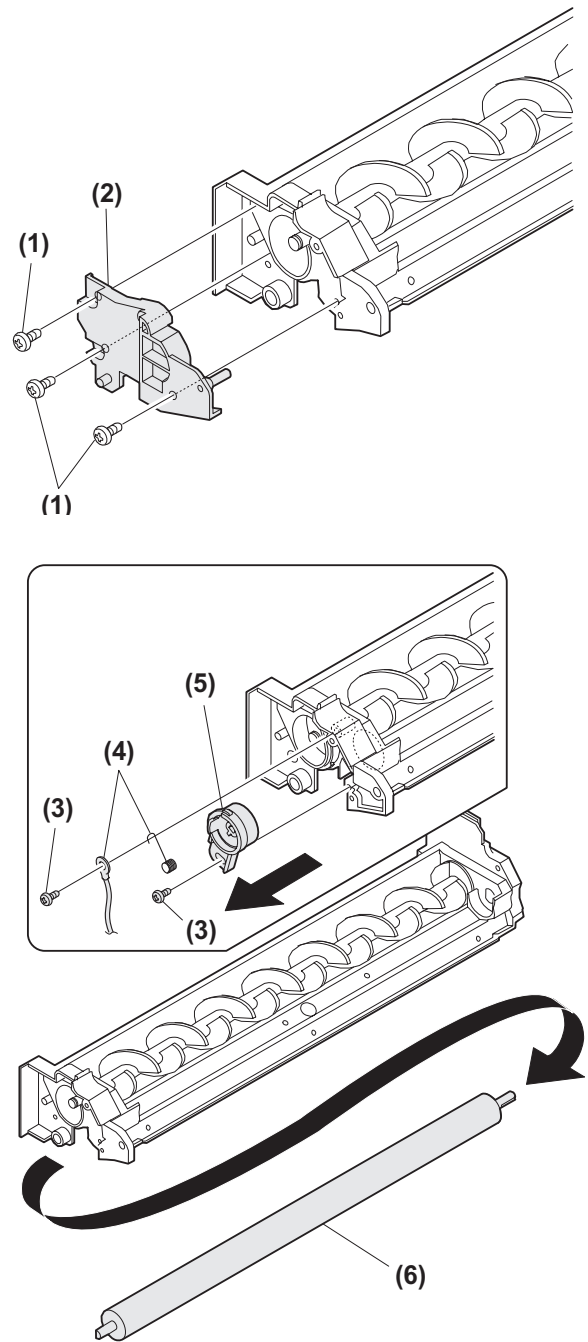

Adjustment: MG roller main pole position adjustment



## 12. Process section

No.	Contents
A	Drum unit
B	MC holder unit
C	Cleaning blade

### A. Drum unit

Assembly: When installing the drum cover (1), be sure to engage the transport screw gear (A) rib and the detection gear (B).

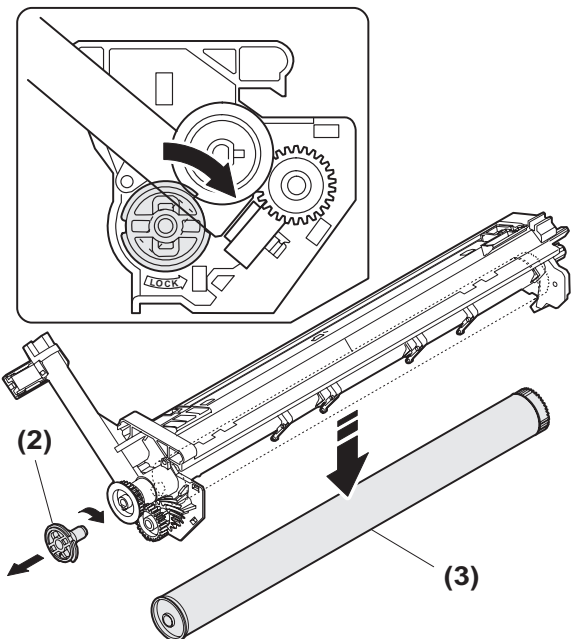
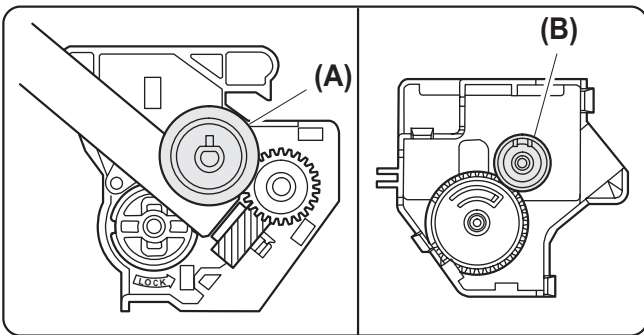
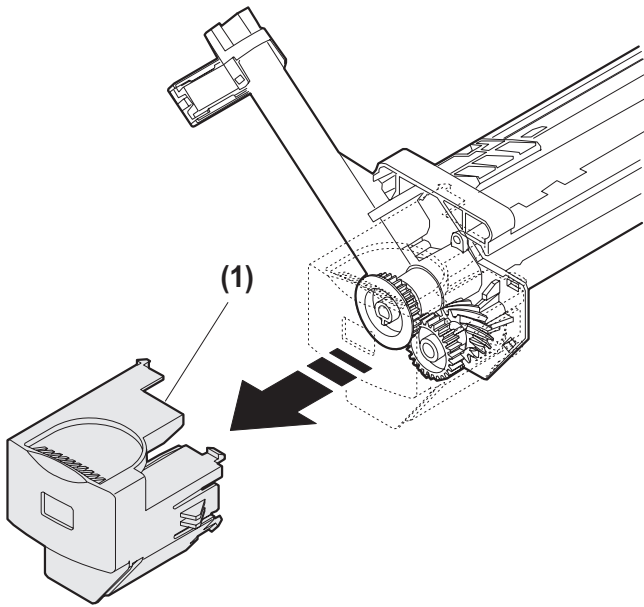

### B. MC holder unit

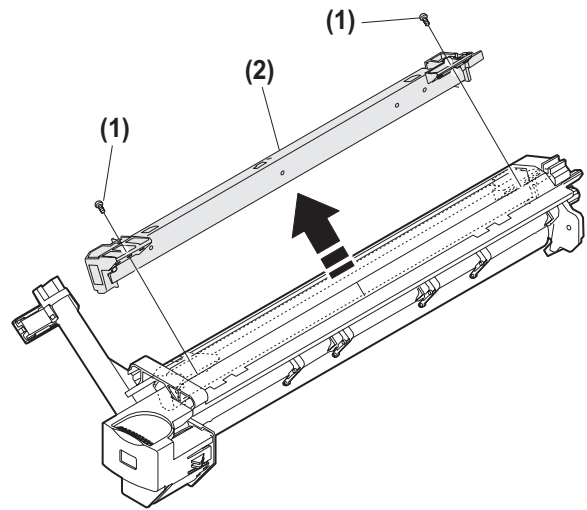

### C. Cleaning blade

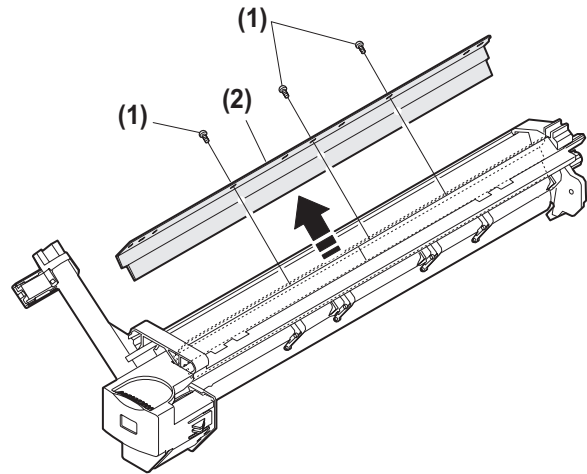

# [13] ELECTRICAL SECTION

## 1. Outline

### A. Block diagram

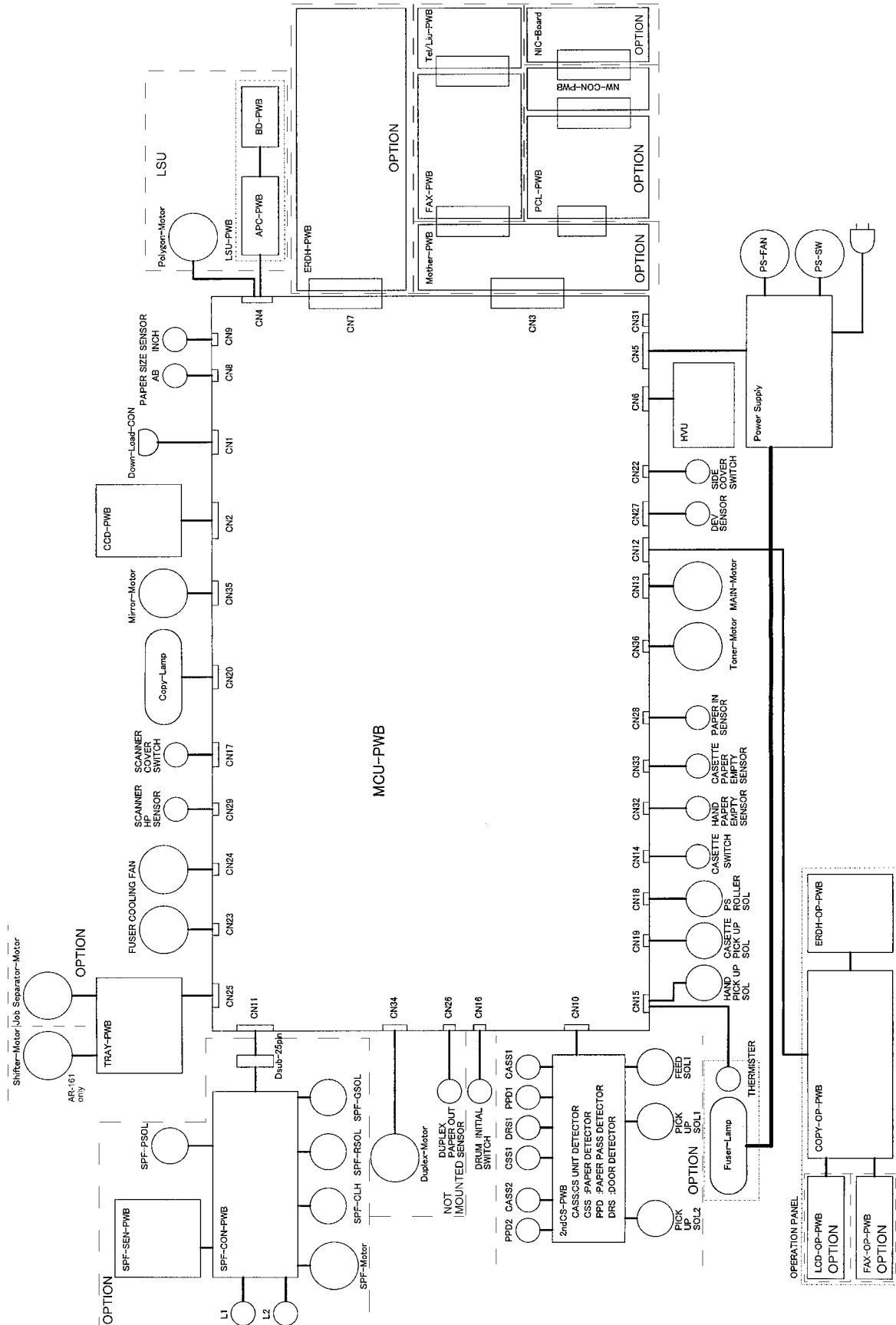

## 2. MCU

### (1) Block diagram (MCU)

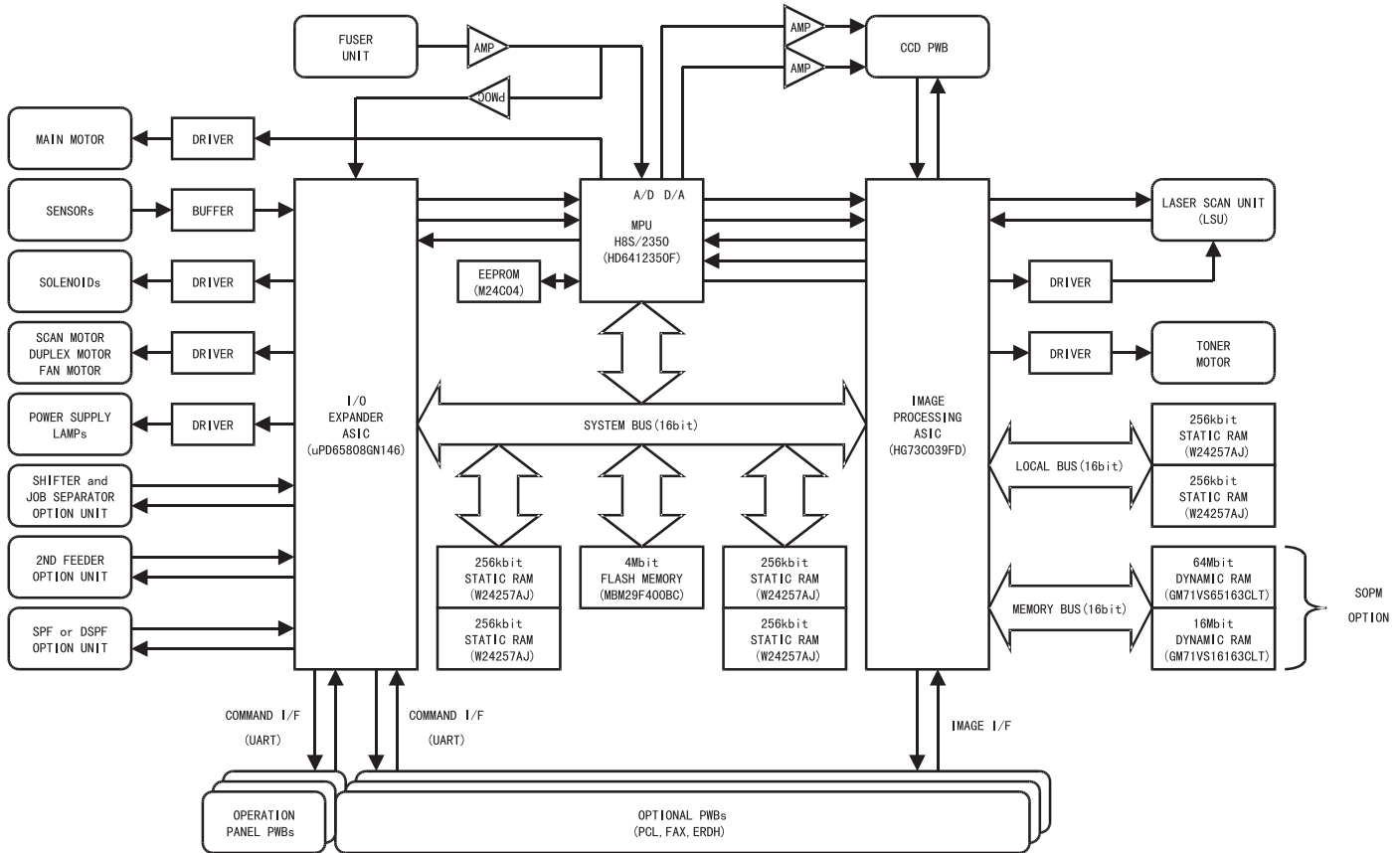

### (2) CPU (HD6412351IF)

#### a. pin/signal table

Pin No.	Pin name	Signal name	I/O	Function	Purpose	Descriptions
1	/CS1	/CS1	OUT	Area 1 chip select	SRAM chip select	L: Select
2	/CS0	/CS0	OUT	Area 0 chip select	Flash ROM chip select	L: Select
3	VSS		POW	Ground pin		
4	VSS		POW	Ground pin		
5	VCC		POW	Power pin		
6	A0	A0	OUT	Address bus 0	System bus	
7	A1	A1	OUT	Address bus 1	System bus	
8	A2	A2	OUT	Address bus 2	System bus	
9	A3	A3	OUT	Address bus 3	System bus	
10	VSS		POW	Ground pin		
11	A4	A4	OUT	Address bus 4	System bus	
12	A5	A5	OUT	Address bus 5	System bus	
13	A6	A6	OUT	Address bus 6	System bus	
14	A7	A7	OUT	Address bus 7	System bus	
15	A8	A8	OUT	Address bus 8	System bus	
16	A9	A9	OUT	Address bus 9	System bus	
17	A10	A10	OUT	Address bus 10	System bus	
18	A11	A11	OUT	Address bus 11	System bus	
19	VSS		POW	Ground pin		
20	A12	A12	OUT	Address bus 12	System bus	
21	A13	A13	OUT	Address bus 13	System bus	

(Pin descriptions) IN: Input pin OUT: Output pin BIDIR: Bi-directional pin ODN: Open drain output pin TR1: 3-state output pin POW: Power pin



Pin No.	Pin name	Signal name	I/O	Function	Purpose	Descriptions
22	A14	A14	OUT	Address bus 14	System bus	
23	A15	A15	OUT	Address bus 15	System bus	
24	A16	A16	OUT	Address bus 16	System bus	
25	A17	A17	OUT	Address bus 17	System bus	
26	A18	A18	OUT	Address bus 18	System bus	
27	A19	A19	OUT	Address bus 19	System bus	
28	VSS		POW	Ground pin		
29	A20	A20	OUT	Address bus 20	System bus	
30	/IRQ5	/SPFCOVER	IN	Interruption request 5	SPF cover sensor interruption	1: Cover close
31	/IRQ6	/OCCCOVER	IN	Interruption request 6	OC cover sensor interruption	0: Cover close
32	/IRQ7	MHP	IN	Interruption request 7	Mirror home position sensor interruption	1: Home position
33	/IRQ3	/SPFPAPER	IN	Interruption request 3	SPF paper pass sensor interruption	0: Paper presence
34	/IRQ2	/CPUSYNC	IN	Interruption request 2	Horizontal sync signal interruption	0: Effective
35	VSS		POW	Ground pin		
36	VSS		POW	Ground pin		
37	/IRQ1	/FW	IN	Interruption request 1	Zero cross interruption	0: Effective
38	/IRQ0	/LOOPINT	IN	Interruption request 0	Loop interruption	0: Effective
39	VCC		POW	Power pin		
40	D0	D0	BIDIR	Data bus 0	System bus	
41	D1	D1	BIDIR	Data bus 1	System bus	
42	D2	D2	BIDIR	Data bus 2	System bus	
43	D3	D3	BIDIR	Data bus 3	System bus	
44	VSS		POW	Ground pin		
45	D4	D4	BIDIR	Data bus 4	System bus	
46	D5	D5	BIDIR	Data bus 5	System bus	
47	D6	D6	BIDIR	Data bus 6	System bus	
48	D7	D7	BIDIR	Data bus 7	System bus	
49	D8	D8	BIDIR	Data bus 8	System bus	
50	D9	D9	BIDIR	Data bus 9	System bus	
51	D10	D10	BIDIR	Data bus 10	System bus	
52	D11	D11	BIDIR	Data bus 11	System bus	
53	VSS		POW	Ground pin		
54	D12	D12	BIDIR	Data bus 12	System bus	
55	D13	D13	BIDIR	Data bus 13	System bus	
56	D14	D14	BIDIR	Data bus 14	System bus	
57	D15	D15	BIDIR	Data bus 15	System bus	
58	VCC		POW	Power pin		
59	P30	—	OUT	General port 30	Reservation	L: Level fixing output
60	TXD1	TXD1	OUT	SCI channel 1 serial transmission	Service connector	UART serial output
61	P32	SDA	ODN	General port 32	EEPROM control	12CBUS data line
62	RXD1	RXD1	IN	SCI channel 1 serial reception	Service connector	UART input
63	P34	SCL	ODN	General port 34	EEPROM control	12CBUS clock line
64	P35	/FROMUP	IN	General port 35	Service connector	0: Service mode
65	VSS		POW	Ground pin		
66	/DREQ0	/DREQ0	IN	DMAC channel 0 external request	Mirror and SPF motor acceleration/reduction control	0: Request effective
67	VSS		POW	Ground pin		
68	VSS		POW	Ground pin		
69	/CS5	—	OUT	Area 5 chip select	Reservation	L: Select
70	/DREQ1	/DREQ1	IN	DMAC channel 1 external request	Lifter and separator motor acceleration/reduction control	0: Request effective
71	P63	POFFR	OUT	General port 63	Power off relay control	H: AC switch OFF
72	P27	/ESPAGE	IN	General port 27	ERDH option page signal detection	0: Page effective
73	P26	/PCLPAGE	IN	General port 26	PCI operation page signal detection	0: Page effective

(Pin descriptions) IN: Input pin OUT: Output pin BIDIR: Bi-directional pin ODN: Open drain output pin TR1: 3-state output pin POW: Power pin

Pin No.	Pin name	Signal name	I/O	Function	Purpose	Descriptions
74	P25	/FAXPAGE	IN	General port 25	FAX option page signal detection	0: Page effective
75	P24	/READY	OUT	General port 24	Machine ready signal	L: Machine ready state
76	P23	/PWOFF	OUT	General port 23	Power off signal	L: Power interruption detecting state
77	P22	/SCANSP	OUT	General port 22	Scan stop signal	L: Scanning operation interruption
78	P21	/SCANST	OUT	General port 21	Scan start signal	L: Scanning operation effective
79	P20	/PRSTART	OUT	General port 20	Print start signal	L: Printing effective
80	/WDTOVR	—	OUT	Watch dog timer overflow	System reset	L: System restart
81	/RES	—	IN	System reset	System reset	0: Power on reset
82	NMI	—	IN	Non-maskable interruption request	Reservation	1: Level fixing input
83	/STBY	—	IN	Stand-by	Reservation	1: Level fixing input
84	VCC		POW	Power pin		
85	XTAL	—	IN	Oscillation pin	Oscillator (19.6608MHz)	
86	EXTAL	—	OUT	Oscillation pin	Oscillator (19.6608MHz)	
87	VSS		POW	Ground pin		
88	â	CPUCLK	OUT	System clock	System clock	19.6608MHz clock output
89	VCC		POW	Power pin		
90	/AS	/AS	OUT	Address strobe	System bus	L: Address effective
91	/RD	/RD	OUT	Lead strobe	System bus	L: Lead effective
92	/HWR	/HWR	OUT	Highlight enable	System bus	L: Highlight effective
93	/LWR	/LWR	OUT	Row write enable	System bus	L: Row write effective
94	PF2	/TMEN	OUT	General port F2	Toner motor drive control	L: Rotating
95	PF1	PMD	OUT	General port F1	Polygon motor drive control	H: Rotating
96	PF0	MMD	OUT	General port F0	Main motor drive control	H: Rotating
97	P50	/MMRDY	IN	General port 50	Main motor ready signal	0: Rotation stable state
98	P51	/PMRDY	IN	General port 51	Polygon motor ready signal	0: Rotation stable state
99	VSS		POW	Ground pin		
100	VSS		POW	Ground pin		
101	P52	/PRLINE	OUT	General port 52	Print line signal	L: Printing effective
102	P53	/SCLINE	OUT	General port 53	Scan line signal	L: Scanning operation effective
103	AVCC		POW	Analog power pin		
104	VREF		POW	Analog reference pin		
105	AN0	RTH	IN	Analog input 0	Fusing thermistor temperature detection	
106	AN1	—	IN	Analog input 1	Reservation	
107	AN2	—	IN	Analog input 2	Reservation	
108	AN3	TONER	IN	Analog input 3	Toner sensor	5V: Toner empty
109	AN4	—	IN	Analog input 4	Reservation	
110	AN5	—	IN	Analog input 5	Reservation	
111	DA0	DA0	OUT	Analog output 0	CCD reference + side	
112	DA1	DA1	OUT	Analog output 1	CCD reference – side	
113	AVSS		POW	Analog ground pin		
114	VSS		POW	Ground pin		
115	TCLKD	LFTCLK	IN	Timer clock external input	Separator motor step count	Separator motor clock input
116	TIOCA2	TMCLK	OUT	Timer clock external output	Toner motor clock	960Hz clock output
117	TCLKC	SFTCLK	IN	Timer clock external input	Shifter motor step count	Shifter motor clock input
118	TIOCA1	PMCLK	OUT	Timer clock external output	Polygon motor clock	2078.74Hz clock output
119	TCLKB	SPFCLK	IN	Timer clock external input	SPF motor step count	SPF motor clock input
120	TCLKA	MIRCLK	IN	Timer clock external input	Mirror motor step count	Mirror motor clock input
121	/DACK1	—	OUT	DMAC channel 1 acknowledge	Reservation	L: Acknowledge effective
122	/DACK0	—	OUT	DMAC channel 0 acknowledge	Reservation	L: Acknowledge effective
123	MD0	—	IN	Operation mode setting pin 0	Operation mode setting (MODE 4)	Operation mode 4

(Pin descriptions) IN: Input pin OUT: Output pin BIDIR: Bi-directional pin ODN: Open drain output pin TR1: 3-state output pin POW: Power pin

Pin No.	Pin name	Signal name	I/O	Function	Purpose	Descriptions
124	MD1	—	IN	Operation mode setting pin 1	Operation mode setting (MODE 4)	Operation mode 4
125	MD2	—	IN	Operation mode setting pin 2	Operation mode setting (MODE 4)	Operation mode 4
126	PG0	RY/BY	IN	General port G0	Flash ROM busy signal	0: Busy state
127	/CS3	/CS3	OUT	Area 3 chip select	I/O extension ASIC chip select	L: Select effective
128	/CS2	/CS2	OUT	Area 2 chip select	Image ASIC chip select	L: Select effective

(Pin descriptions) IN: Input pin OUT: Output pin BIDIR: Bi-directional pin ODN: Open drain output pin TR1: 3-state output pin POW: Power pin

### (3) Image ASIC (HG73C039FD)

#### a. Outline

Fig. 4 shows the block diagram of the ASIC.

The ASIC is composed of the following three blocks; the image process section, the print control section, and the I/F section.

The image process section processes the image data from the CCD PWB according to the operation mode, such as shading, AE process, resolution conversion, and zooming.

The print control section outputs the image-processed data during copying to the LSU (Laser unit) in synchronization with writing timing of the LSU.

The I/F section controls communication of interface (IEEE1284) with the host PC and controls DRAM of send/receive data buffer with the host PC. (Only for models with the printer function)

The ASIC is controlled by the CPU which writes the operation mode and the set values necessary for each operation mode to the ASIC control register.

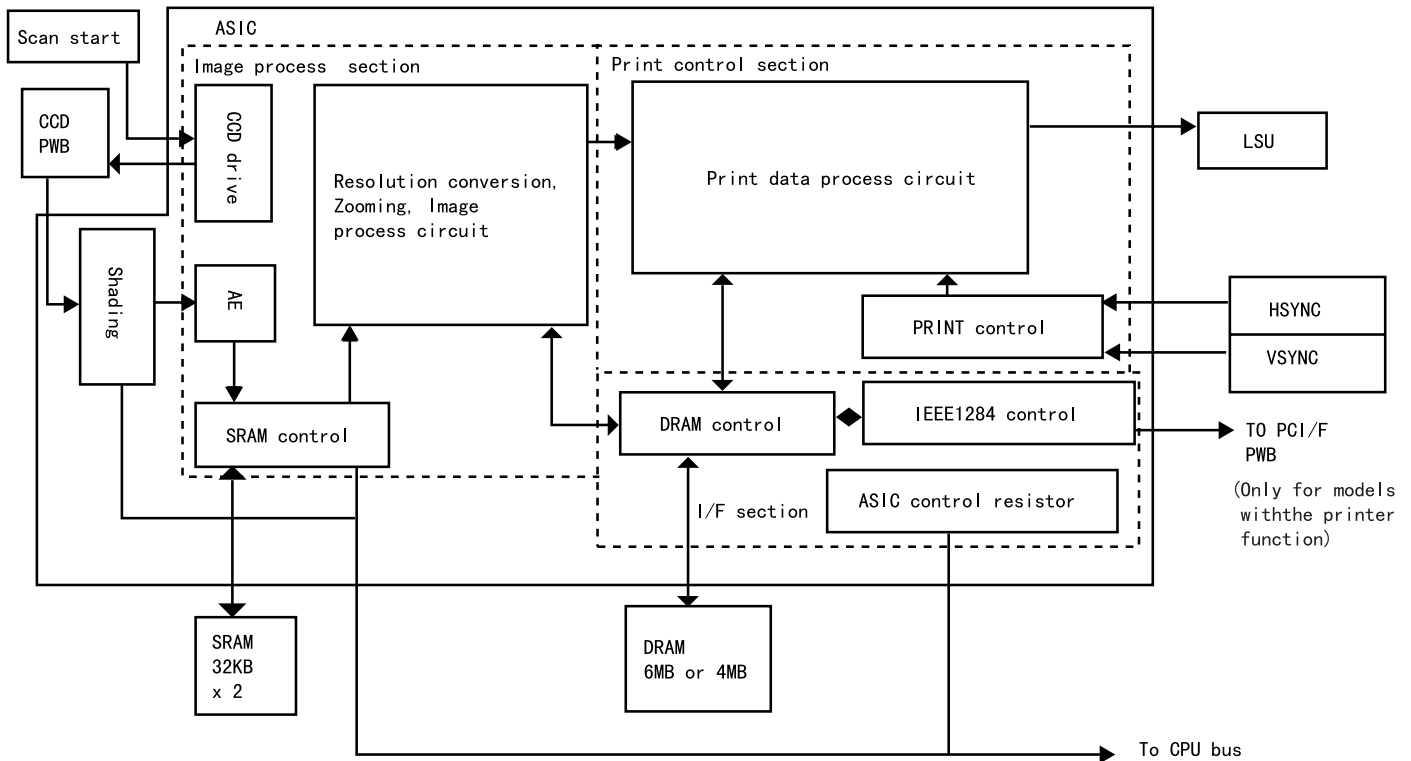

#### b. pin/signal table

PIN No.	Signal name	IN/OUT	Description
1	/SCANSPP	IN	Scanner process interrupt signal
2	/PRSTART	IN	Print start trigger signal
3	TMON	IN	Toner motor ON/OFF
4	TMCLK	IN	Toner motor reference clock
5	3.3V	Power	
6	CPUAD7	IN	CPU address bus
7	CPUAD6	IN	
8	GND	Power	
9	CPUAD5	IN	CPU address bus
10	CPUAD4	IN	
11	CPUAD3	IN	
12	CPUAD2	IN	
13	CPUAD1	IN	

PIN No.	Signal name	IN/OUT	Description
14	/CPUSYNC	OUT	Horizontal synchronization signal
15	/INTR	OUT	Interruption request signal
16	/CPUCS	IN	CPU chip select signal
17	/RESET	IN	Reset signal
18	5V	Power	
19	GND	Power	
20	3.3V	Power	
21	GND	Power	
22	MDATA15	IN/OUT	Data bus of DRAM (page memory)
23	MDATA14	IN/OUT	
24	MDATA13	IN/OUT	
25	MDATA12	IN/OUT	
26	MDATA11	IN/OUT	

PIN No.	Signal name	IN/OUT	Description
27	MDATA10	IN/OUT	Data bus of DRAM (page memory)
28	MDATA9	IN/OUT	
29	MDATA8	IN/OUT	
30	MDATA7	IN/OUT	
31	3.3V	Power	
32	MDATA6	IN/OUT	Data bus of DRAM (page memory)
33	MDATA5	IN/OUT	
34	GND	Power	
35	MDATA4	IN/OUT	Data bus of DRAM (page memory)
36	MDATA3	IN/OUT	
37	MDATA2	IN/OUT	
38	MDATA1	IN/OUT	
39	MDATA0	IN/OUT	
40	/RAS0	OUT	RAS signal 0 of DRAM (page memory)
41	/RAS1	OUT	RAS signal 1 of DRAM (page memory)
42	/RAS2	OUT	RAS signal 2 of DRAM (page memory)
43	/RAS64	OUT	(Not used)
44	3.3V	Power	
45	/RAS16	OUT	(Not used)
46	MAD0	OUT	Address bus of DRAM (page memory)
47	GND	Power	
48	MAD1	OUT	Address bus of DRAM (page memory)
49	MAD2	OUT	
50	MAD3	OUT	
51	MAD4	OUT	
52	MAD5	OUT	
53	MAD6	OUT	
54	MAD7	OUT	
55	MAD8	OUT	
56	MAD9	OUT	
57	3.3V	Power	
58	MAD10	OUT	Address bus of DRAM (page memory)
59	MAD11	OUT	
60	GND	Power	
61	/CAS0	OUT	CAS signal of DRAM (page memory)
62	/CAS1	OUT	
63	/OE	OUT	Read enable signal of DRAM (page memory)
64	/WE	OUT	Write enable signal of DRAM (page memory)
65	OUTD0	OUT	(Not used)
66	OUTD1	OUT	
67	OUTD2	OUT	
68	OUTD3	OUT	
69	3.3V	Power	
70	OUTD4	OUT	(Not used)
71	OUTD5	OUT	
72	GND	Power	
73	OUTD6	OUT	(Not used)
74	OUTD7	OUT	
75	OUTD8	OUT	
76	OUTD9	OUT	
77	OUTD11	OUT	
78	OUTD10	OUT	
79	OUTD12	OUT	
80	OUTD13	OUT	
81	OUTD14	OUT	
82	OUTD15	OUT	

PIN No.	Signal name	IN/OUT	Description
83	/HSYNC	OUT	(Not used)
84	/PCLPRD	IN	
85	/PCLREQ	OUT	
86	/PCLACK	IN	
87	/PCLCS	IN	
88	3.3V	Power	
89	GND	Power	
90	5V	Power	
91	GND	Power	
92	/FAXPRD	IN	(Not used)
93	/FAXREQ	OUT	
94	/FAXACK	IN	
95	3.3V	Power	
96	/FAXCS	IN	(Not used)
97	/ESPRD	IN	
98	GND	Power	
99	/ESREQ	OUT	(Not used)
100	/ESACK	IN	
101	/ESCS	IN	
102	PARAD0	IN/OUT	
103	PARAD1	IN/OUT	
104	PARAD2	IN/OUT	
105	PARAD3	IN/OUT	
106	PARAD4	IN/OUT	
107	PARAD5	IN/OUT	
108	5V	Power	
109	PARAD6	IN/OUT	(Not used)
110	PARAD7	IN/OUT	
111	GND	Power	
112	/REV	OUT	(Not used)
113	INIT	IN	
114	/SLCTIN	IN	
115	/AUTOFD	IN	
116	/STB	IN	
117	/ACK	OUT	
118	BUSY	OUT	
119	PE	OUT	
120	/FAULT	OUT	
121	5V	Power	
122	SLCT	OUT	(Not used)
123	/TESTPIN0	IN	High: Normal Low: Test
124	GND	Power	
125	PFCLK	IN	Write clock
126	/TESTPIN1	IN	High: Normal Low: Test
127	/SYNCEN	OUT	Jitter adjustment IC trigger signal
128	SD10	IN/OUT	Data line to SRAM before are separation
129	SD11	IN/OUT	
130	SD12	IN/OUT	
131	SD13	IN/OUT	
132	SD14	IN/OUT	
133	5V	Power	
134	SD15	IN/OUT	Data line to SRAM before are separation
135	SD16	IN/OUT	
136	GND	Power	
137	SD17	IN/OUT	Data line to SRAM before are separation
138	SOE1	OUT	Read enable line to SRAM before area separation
139	SWE1	OUT	Write enable line to SRAM before area separation
140	SCS1	OUT	Chip select line to SRAM before area separation

PIN No.	Signal name	IN/OUT	Description
141	SOE0	OUT	Read enable line to SRAM before area separation
142	SWE0	OUT	Write enable line to SRAM before area separation
143	SCS0	OUT	Chip select line to SRAM before area separation
144	SD00	IN/OUT	Data line to SRAM before are separation
145	SD01	IN/OUT	
146	5V	Power	
147	SD02	IN/OUT	Data line to SRAM before are separation
148	SD03	IN/OUT	
149	GND	Power	
150	SD04	IN/OUT	Data line to SRAM before are separation
151	SD05	IN/OUT	
152	SD06	IN/OUT	
153	SD07	IN/OUT	
154	SAD0	OUT	Address line to SRAM before area separation
155	SAD1	OUT	
156	SAD2	OUT	
157	SAD3	OUT	
158	SAD4	OUT	
159	SAD5	OUT	
160	SAD6	OUT	
161	SAD7	OUT	
162	GND	Power	
163	SAD8	OUT	Address line to SRAM before area separation
164	SAD9	OUT	
165	SAD10	OUT	
166	SAD11	OUT	
167	SAD12	OUT	
168	SAD13	OUT	
169	/f1	OUT	CCD drive signal transfer clock (First phase)
170	/f2	OUT	CCD drive signal transfer clock (Second phase)
171	/SH	OUT	CCD drive signal shift pulse
172	5V	Power	
173	RS	OUT	CCD drive signal reset pulse
174	SP	OUT	CCD drive signal sampling hold pulse
175	GND	Power	
176	CP	OUT	A/D conversion IC latch clock
177	BCLK	OUT	CCD shield output latch signal
178	IDIN0	IN	Image scan data (after 8bit A/D conversion)
179	IDIN1	IN	
180	IDIN2	IN	
181	IDIN3	IN	
182	IDIN4	IN	
183	IDIN5	IN	
184	IDIN6	IN	
185	5V	Power	
186	IDIN7	IN	Image scan data (after 8bit A/D conversion)
187	/SDCLK	OUT	Effective image area signal
188	GND	Power	
189	SFCLK	IN	CCD drive clock (48MHz)
190	TEST port 0	IN	High: Normal Low: Test
191	/SYNC	IN	Horizontal synchronization signal (HSYNC) from LSU
192	/LD	OUT	Laser drive signal
193	/LEND	OUT	Laser APC signal
194	/VIDEPCS	OUT	Video data control
195	—	OUT	NC

PIN No.	Signal name	IN/OUT	Description
196	—	OUT	NC
197	3.3V	Power	
198	—	OUT	NC
199	—	OUT	
200	GND	Power	
201	—	OUT	NC
202	—	OUT	
203	—	OUT	
204	—	OUT	
205	—	OUT	
206	—	OUT	
207	—	OUT	
208	—	OUT	
209	—	OUT	
210	3.3V	Power	
211	—	OUT	NC
212	—	OUT	
213	GND	Power	
214	/PCLPCS	OUT	PCL option print data control
215	/FAXPCS	OUT	FAX option print data control
216	/ESPCS	OUT	Electronic sort option print data control
217	—	OUT	NC
218	CV_START	OUT	Copy vendor control
219	CV_COUNT	OUT	
220	CV_SIZE3	OUT	
221	CV_SIZE2	OUT	
222	CV_SIZE1	OUT	
223	5V	Power	
224	CV_SIZE0	OUT	Copy vendor control
225	CV_DPX	OUT	
226	GND	Power	
227	CV_CA	OUT	Copy vendor control
228	—	OUT	NC
229	TM	OUT	Toner motor drive output (+)
230	TM_	OUT	Toner motor drive output (-)
231	CPUD15	IN/OUT	CPU data bus
232	CPUD14	IN/OUT	
233	CPUD13	IN/OUT	
234	CPUD12	IN/OUT	
235	CPUD11	IN/OUT	
236	5V	Power	
237	CPUD10	IN/OUT	CPU data bus
238	CPUD9	IN/OUT	
239	GND	Power	
240	CPUD8	IN/OUT	CPU data bus
241	CPUD7	IN/OUT	
242	CPUD6	IN/OUT	
243	CPUD5	IN/OUT	
244	CPUD4	IN/OUT	
245	CPUD3	IN/OUT	
246	CPUD2	IN/OUT	
247	CPUD1	IN/OUT	
248	CPUD0	IN/OUT	
249	3.3V	Power	
250	/CPUWR	IN	CPU write signal
251	/CPURD	IN	CPU read signal
252	GND	Power	
253	CPUCLK	IN	CPU system clock
254	GND	Power	
255	TEST PORT1	IN	High: Normal Low: Test
256	/SCANST	IN	Scanner process start signal

**(4) I/O ASIC****a. pin/signal table**

Pin No.	Pin name	Signal name	I/O	Purpose	Descriptions
1	GND		POW		
2	GND		POW		
3	SCK		IN		0: Level fixing input
4	AMC		IN		0: Level fixing input
5	SMC		IN		0: Level fixing input
6	UART0SIN/SIN	OPECMD	IN	Operation panel command interface	
7	UART0SOUT/SOT	OPESTS	OUT	Operation panel command interface	
8	UART0CTSB	/OPESRDY	IN	Operation panel command interface	
9	UART0RTSB	/OPECRDY	OUT	Operation panel command interface	
10	GND		POW		
11	UART1SIN	OPECMD	IN	Electronic sort option command interface	
12	UART1SOUT	OPESTS	OUT	Electronic sort option command interface	
13	UART1CTSB	/OPESRDY	IN	Electronic sort option command interface	
14	UART1RTSB	/OPECRDY	OUT	Electronic sort option command interface	
15	UART2SIN	OPECMD	IN	FAX option command interface	
16	VCC		POW		
17	UART2SOUT	OPESTS	OUT	FAX option command interface	
18	UART2CTSB	/OPESRDY	IN	FAX option command interface	
19	UART2RTSB	/OPECRDY	OUT	FAX option command interface	
20	GND		POW		
21	VCC		POW		
22	GND		POW		
23	UART3SIN	OPECMD	IN	PQL option command interface	
24	UART3SOUT	OPESTS	OUT	PQL option command interface	
25	UART3CTSB	/OPESRDY	IN	PQL option command interface	
26	UART3RTSB	/OPECRDY	OUT	PQL option command interface	
27	VCC		POW		
28	DSLED1	LED1	OUT	3; Beam document size sensor control	
29	DSLED2	LED2	OUT	3; Beam document size sensor control	
30	DSLED3	LED3	OUT	3; Beam document size sensor control	
31	DSIN0	DSIN1	IN	1: Beam document size sensor detection	
32	GND		POW		
33	DSIN1	DSIN2A	IN	2: Beam document size sensor A detection	
34	DSIN2	DSIN2B	IN	2: Beam document size sensor B detection	
35	DSIN3	DS3IN	IN	3: Beam document size sensor detection	
36	PMC0POUT0	MIRMODA	OUT	Mirror motor phase A drive	H: Drive
37	VCC		POW		
38	PMC0POUT1	MIRMODB	OUT	Mirror motor phase B drive	H: Drive
39	PMC0POUT2	/MIRMODA	OUT	Mirror motor phase /A drive	H: Drive
40	VCC		POW		
41	GND		POW		
42	GND		POW		
43	PMC0POUT3	/MIRMODB	OUT	Mirror motor phase /B drive	H: Drive
44	PMC2POUT0	SFTDA	OUT	Shifter motor phase A drive	H: Drive
45	PMC2POUT1	SFTDB	OUT	Shifter motor phase B drive	H: Drive
46	PMC2POUT2	/SFTDA	OUT	Shifter motor phase /A drive	H: Drive
47	VCC		POW		
48	PMC2POUT3	/SFTDB	OUT	Shifter motor phase /B drive	H: Drive
49	PMC3POUT0	LFTDA	OUT	Separator motor phase A drive	H: Drive
50	PMC3POUT1	LFTDB	OUT	Separator motor phase B drive	H: Drive
51	PMC3POUT2	/LFTDA	OUT	Separator motor phase /A drive	H: Drive
52	GND		POW		
53	PMC3POUT3	/LFTDB	OUT	Separator motor phase /B drive	H: Drive
54	PMC4POUT0	DPXDA	OUT	Duplex motor phase A drive	H: Drive
55	PMC4POUT1	DPXDB	OUT	Duplex motor phase B drive	H: Drive
56	PMC4POUT2	/DPXDA	OUT	Duplex motor phase /A drive	H: Drive
57	TESTB		IN		1: Level fixing input
58	TESTB		IN		1: Level fixing input
59	GND		POW		

(Pin descriptions) IN: Input pin OUT: Output pin BIDIR: Bi-directional pin ODN: Open drain output pin TR1: 3-state output pin POW: Power pin

Pin No.	Pin name	Signal name	I/O	Purpose	Descriptions
60	GND		POW		
61	VCC		POW		
62	PMC4POUT3	/DPXDB	OUT	Duplex motor phase /B drive	H: Drive
63	PWM0POUT	PFANMD	OUT	Power fan motor drive	H: Drive
64	PWM1POUT	TFANMD	OUT	Fusing fan motor drive	H: Drive
65	P0OUT8	SOPHIA	OUT	(Not used)	
66	P0OUT9	/LOOPINT	OUT	Loop interruption control	L: Interruption
67	P0OUT10	—	OUT	(Not used)	
68	P0OUT11	—	OUT	(Not used)	
69	GND		POW		
70	P0OUT12	MIRMO0	OUT	Mirror motor phase current control 0	H: Power down
71	P0OUT13	MIRMO1	OUT	Mirror motor phase current control 1	H: Power down
72	P0OUT14	PDOWN	OUT	SPF motor phase current control	H: Power down
73	P0OUT15	—	OUT	(Not used)	
74	P1OUT12	SPFPSOL	OUT	SPF pickup solenoid drive	H: Drive
75	P1OUT13	SPFGSOL	OUT	SPF gate solenoid	H: Drive
76	P1OUT14	SPFRSOL	OUT	SPF release solenoid drive	H: Drive
77	VCC		POW		
78	P1OUT15	SPFCLH	OUT	SPF clutch solenoid	H: Drive
79	P0IN0	PIN	IN	Paper in sensor detection	1: Paper presence
80	GND		POW		
81	VCC		POW		
82	P0IN1	POUT	IN	Paper out sensor detection	1: Paper presence
83	P0IN2	PDPX	IN	Duplex control sensor detection	0: Paper presence
84	P0IN3	LFTHP	IN	Separator home position sensor detection	1: Home position
85	GND		POW		
86	P0IN4	/SFTHP	IN	Shifter home position sensor detection	0: Home position
87	P0IN5	PFULL	IN	Tray paper full sensor detection	1: Paper full
88	P0IN6	MHP	IN	Mirror home position sensor detection	1: Home position
89	VCC		POW		
90	GND		POW		
91	PFCLK	PFCLK	IN	Dot count control	
92	GND		POW		
93	GND		POW		
94	LDB	/VIDEO	IN	Dot count control	0: Effective
95	LENDDB	S/H	IN	Dot count control	0: Effective
96	VCC		POW		
97	P0IN7	/CV_COPY	IN	Coin vendor copy enable detection	0: Copy enabled
98	P0IN8	/HTEMP	IN	Fusing thermistor abnormally high temperature detection	0: Abnormally high temperature
99	P0IN9	/THOPEN	IN	Fusing thermistor disconnection detection	0: Wire disconnection
100	VCC		POW		
101	GND		POW		
102	P0IN10	CASSETTE	IN	Copier cassette switch detection	1: Cassette installed
103	P0IN11	/CPEMPTY	IN	Copier cassette paper empty sensor detection	0: Paper empty
104	GND		POW		
105	P0IN12	HPEMPTY	IN	Manual feed tray paper empty sensor detection	1: Paper empty
106	P0IN13	/DEV	IN	Developing unit installation detection	0: Unit installed
107	P0IN14	DRUM	IN	Drum initial switch detection	1: Drum initial
108	P0IN15	/CSW	IN	Side cover switch detection	0: Cover close
109	P1IN0	/PMEMO	IN	Memory print operation setup jumper detection	1: Operation enabled
110	P1IN1	/CSPEED	IN	Copy speed setup jumper detection	"1: 20ppm, 0: 16ppm"
111	P1IN2	/DPXSW	IN	Duplex print operation setup jumper detection	1: Operation enabled
112	VCC		POW		
113	P1IN3	/SFTSW	IN	Shifter operation setup jumper detection	1: Operation enabled
114	P1IN4	/LFTSW	IN	Separator operation setup jumper detection	1: Operation enabled
115	P1IN5	/INCHSW	IN	Inch series document size sensor setup jumper detection	1: Operation enabled
116	P1IN6	/JPNABSW	IN	Japan AB series document size sensor setup jumper detection	1: Operation enabled
117	P1IN7	/EXJABSW	IN	EX AB series document size sensor setup jumper detection	1: Operation enabled

(Pin descriptions) IN: Input pin OUT: Output pin BIDIR: Bi-directional pin ODN: Open drain output pin TR1: 3-state output pin POW: Power pin

Pin No.	Pin name	Signal name	I/O	Purpose	Descriptions
118	P1IN8	/ESREADY	IN	Electronic sort board option installation detection	0: Option installed
119	P1IN9	/FAXREADY	IN	FAX board option installation detection	0: Option installed
120	VCC		POW		
121	GND		POW		
122	GND		POW		
123	TEST		IN	(Not used)	0: Level fixing input
124	TEST		IN	(Not used)	0: Level fixing input
125	TEST		IN	(Not used)	0: Level fixing input
126	P1IN10	/PCLREADY	IN	FAX board option installation detection	0: Option installed
127	P1IN11	/SPFOPEN	IN	SPF unit float sensor detection	
128	P1IN12	—	IN	(Not used)	
129	P1IN13	—	IN	(Not used)	
130	VCC		POW		
131	P1IN14	—	IN	(Not used)	
132	P1IN15	—	IN	(Not used)	
133	P1OUT0	HPSOL	OUT	Manual feed tray pickup solenoid drive	H: Drive
134	P1OUT1	CPSOL	OUT	Copier cassette pickup solenoid drive	H: Drive
135	GND		POW		
136	P1OUT2	PSRSOL	OUT	PS roller solenoid drive	H: Drive
137	P1OUT3	—	OUT	(Not used)	
138	P1OUT4	—	OUT	(Not used)	
139	GND		POW		
140	VCC		POW		
141	P1OUT5	—	OUT	(Not used)	
142	P1OUT6	PSOL1	OUT	Option cassette 1 pick up solenoid drive	H: Drive
143	P1OUT7	FSOL1	OUT	Option cassette 1 feed solenoid drive	H: Drive
144	P1OUT8	PSOL2	OUT	Option cassette 2 pickup solenoid drive	H: Drive
145	GND		POW		
146	P1OUT9	FSOL2	OUT	Option cassette 2 feed solenoid drive	H: Drive
147	P1OUT10	PSOL3	OUT	Option cassette 3 pickup solenoid drive	H: Drive
148	P1OUT11	FSOL3	OUT	Option cassette 3 feed solenoid drive	H: Drive
149	SEOUT0	SELA	OUT	Option sensor select control	
150	VCC		POW		
151	SEOUT1	SELB	OUT	Option sensor select control	
152	SEOUT2	SELC	OUT	Option sensor select control	
153	YIN0	YSPF	IN	SPF option related sensor	
154	YIN1	Y1	IN	Option cassette 1 related sensor detection	
155	GND		POW		
156	YIN2	Y2	IN	Option cassette 2 related sensor detection	
157	YIN3	Y3	IN	Option cassette 3 related sensor detection	
158	P0OUT0	HL	OUT	Halogen lamp control	H: Lamp ON
159	P0OUT1	CL	OUT	Copy lamp control	H: Lamp ON
160	VCC		POW		
161	GND		POW		
162	P0OUT2	PR	OUT	Power relay control	H: Relay ON
163	P0OUT3	MC	OUT	Main charger voltage control	H; Voltage ON
164	P0OUT4	TC	OUT	Transfer charger voltage control	H; Voltage ON
165	GND		POW		
166	P0OUT5	/GRIDL	OUT	Grid bias voltage control	"H: HIGH, L: LOW "
167	P0OUT6	/BIAS	OUT	Developing bias voltage control	L: Voltage ON
168	P0OUT7	APCSTT	OUT	APC circuit control	H: APC circuit ON
169	PMC0TCLK	MIRCLK	OUT	Mirror motor step count	Mirror motor clock output
170	VCC		POW		
171	PMC0DREQB	—	OUT	(Not used)	
172	PMC1TCLK	SPFCLK	OUT	SPF motor step count	SPF motor clock output
173	PMC1DREQB	—	OUT	(Not used)	
174	PMC2TCLK	SFTCLK	OUT	Shifter motor step count	Shifter motor clock output
175	PMC2DREQB	—	OUT	(Not used)	
176	TEST		IN	(Not used)	0: Level fixing input
177	TESTB		IN	(Not used)	1: Level fixing input
178	TEST		IN	(Not used)	0: Level fixing input
179	GND		POW		

(Pin descriptions) IN: Input pin OUT: Output pin BIDIR: Bi-directional pin ODN: Open drain output pin TR1: 3-state output pin POW: Power pin



Pin No.	Pin name	Signal name	I/O	Purpose	Descriptions
180	GND		POW		
181	VCC		POW		
182	PMC3TCLK	LFTCLK	OUT	Separator motor step count	Separator motor clock output
183	PMC3DREQB	—	OUT	(Not used)	
184	PMC4TCLK	—	OUT	(Not used)	
185	PMC4DREQB	—	OUT	(Not used)	
186	DREQ0B	/DREQ0	OUT	"Mirror, SPF motor acceleration/reduction control"	L: Request
187	DREQ1B	/DREQ1	OUT	"Shifter, separator motor acceleration/reduction control"	L: Request
188	A16	A16	IN	System bus	
189	VCC		POW		
190	CS1B	/CS1	IN	System bus	0: Select
191	CSOUT10B	/CS10	OUT	System bus	L: Select
192	CSOUT11B	/CS11	OUT	System bus	L: Select
193	CS3B	/CS3	IN	System bus	0: Select
194	RDB	/RD	IN	System bus	0: Read
195	HWRB	/HWR	IN	System bus	0: Highlight
196	LWRB	/LWR	IN	System bus	0: Row write
197	GND		POW		
198	A1	A1	IN	System bus	
199	A2	A2	IN	System bus	
200	GND		POW		
201	VCC		POW		
202	A3	A3	IN	System bus	
203	A4	A4	IN	System bus	
204	A5	A5	IN	System bus	
205	VCC		POW		
206	A6	A6	IN	System bus	
207	A7	A7	IN	System bus	
208	GND		POW		
209	RSTB	/RESET	IN	System reset	0: Reset
210	GND		POW		
211	CLK	CPUCLK	IN	System clock	
212	GND		POW		
213	D0	D0	BIDIR	System bus	
214	D1	D1	BIDIR	System bus	
215	D2	D2	BIDIR	System bus	
216	GND		POW		
217	D3	D3	BIDIR	System bus	
218	D4	D4	BIDIR	System bus	
219	D5	D5	BIDIR	System bus	
220	VCC		POW		
221	GND		POW		
222	D6	D6	BIDIR	System bus	
223	D7	D7	BIDIR	System bus	
224	VCC		POW		
225	D8	D8	BIDIR	System bus	
226	D9	D9	BIDIR	System bus	
227	D10	D10	BIDIR	System bus	
228	D11	D11	BIDIR	System bus	
229	D12	D12	BIDIR	System bus	
230	D13	D13	BIDIR	System bus	
231	D14	D14	BIDIR	System bus	
232	GND		POW		
233	D15	D15	BIDIR	System bus	
234	PMC1POUT0	SPFDA	OUT	SPF motor phase A drive	H: Drive
235	PMC1POUT1	SPFDB	OUT	SPF motor phase B drive	H: Drive
236	PMC1POUT2	/SPFDA	OUT	SPF motor phase /A drive	H: Drive
237	PMC1POUT3	/SPFDB	OUT	SPF motor phase /B drive	H: Drive
238	DSCLK	DSCLK	ODN	Document size sensor control	
239	DSLED0	LED0	OUT	2: Beam document size sensor control	
240	VCC		POW		

(Pin descriptions) IN: Input pin OUT: Output pin BIDIR: Bi-directional pin ODN: Open drain output pin TR1: 3-state output pin POW: Power pin

**(5) Reset circuit**

This circuit detects ON/OFF of power to control start/stop of each circuit. The 5V voltage of the main PWB is detected by the reset IC to generate the reset signal.

When the power voltage reaches the specified level, the circuit operations are started. Before the power voltage falls below the specified level, the circuit operations are stopped to prevent against malfunctions.

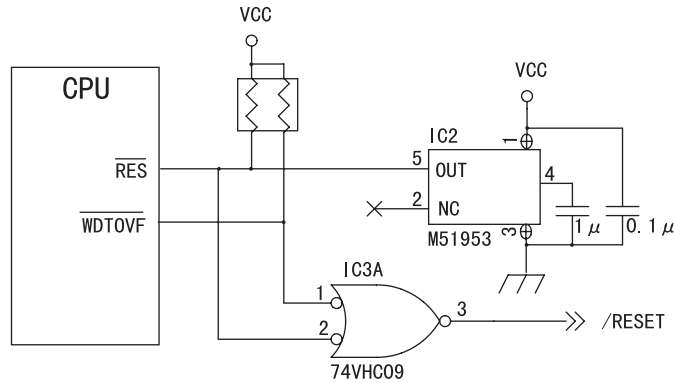

**(6) Main motor drive circuit**

The main motor is driven by the MMD signal from ASIC. While the main motor is rotating, the MMD signal is driven to HIGH and passed through IC35 to the control circuit in the main motor to rotate the main motor. The /MMRDY signal is kept HIGH until the main motor speed reaches the specified rpm, and passed to the CPU.

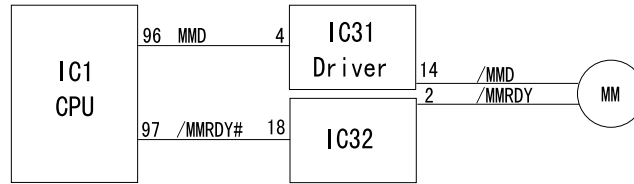

**(7) Mirror motor circuit**

The mirror motor is a stepping motor, and it uses the IC29 and the constant current chopper control IC (SLA7027). For control, the CPU outputs the drive signal to the IC29 to drive the mirror motor with 1-2 phase excitation.

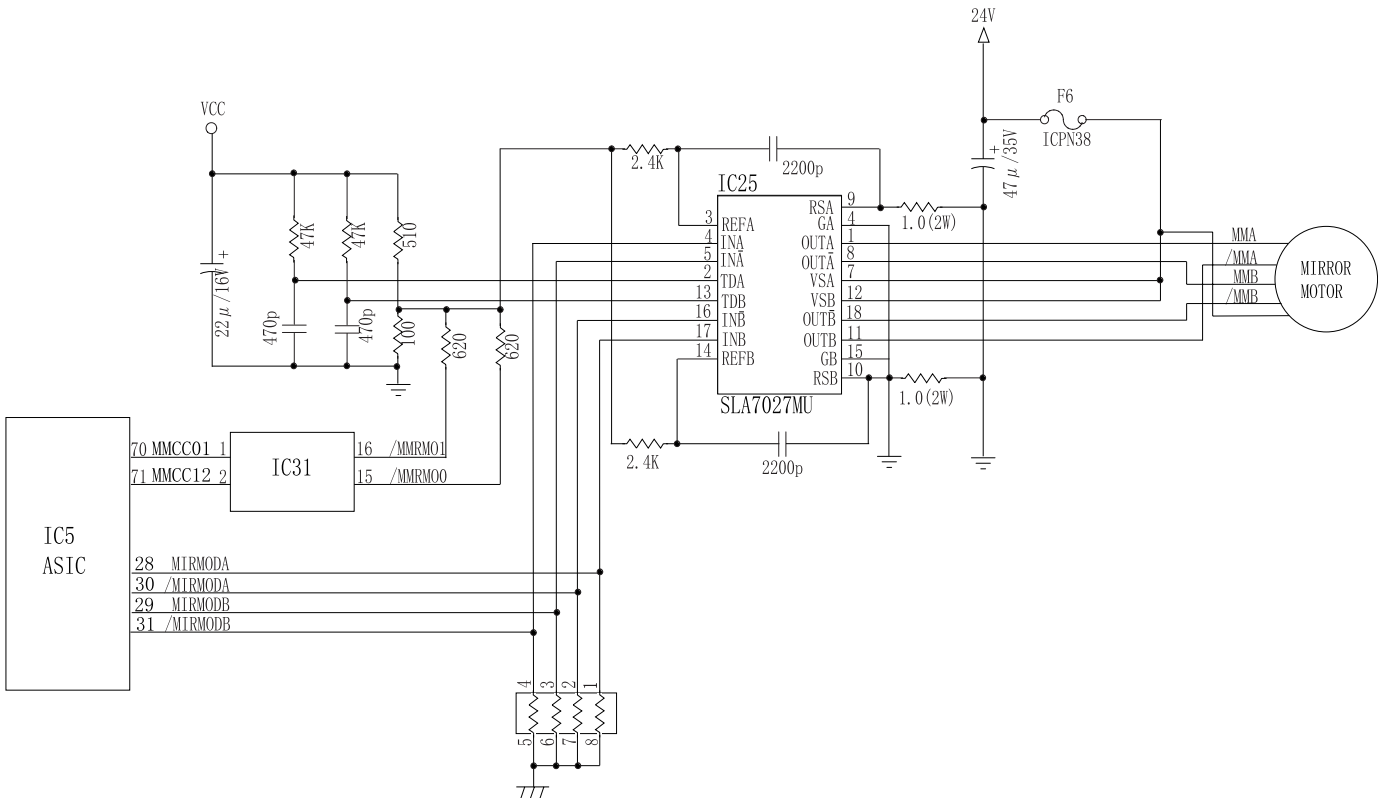

### (8) Toner supply motor drive circuit

The IC31 is the motor control IC, which generates the pseudo AC waveform with the pulse signals (TM, TM-) outputted from ASIC, driving the toner supply motor.

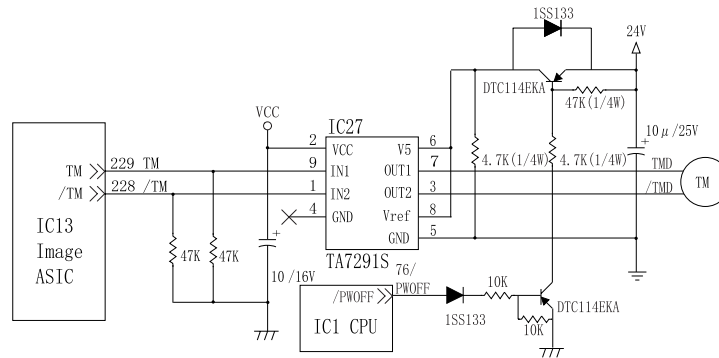

### 3. CCD PWB

The CCD PWB is provided with the CCD (Charge-Coupled Device), the differential amplifier which amplifies image signals, and the AD convertor which converts the amplified image signals into digital signals.

The DC power and the pulse supply pins necessary for operating the CCD image sensor are the power source (CD pin), GND (SS pin), shift pulse (SH pin), transfer pulse ( $\phi$  1 pin), ( $\phi$  2 pin), reset pulse (/RS pin), clamp pulse (/CP pin), and sampling (/SP pin).

Photo data are stored in the light receiving element at the center of the CCD by the SH signal. Even number pixel data are sent to one of the two shift registers which are positioned at both ends of the light receiving element, and odd number pixel data are sent to the other shift register. The time interval between inputting two SH signals is called the photo accumulation time.

The signals are transferred to the register, then to the shift register sequentially by transfer pulses  $\phi$  1 and  $\phi$  2 and to the floating capacitor section where electric signals are voltage-converted. Electric charges from the even number pixel shift register and the odd number pixel shift register are flowed to the floating capacitor section alternatively.

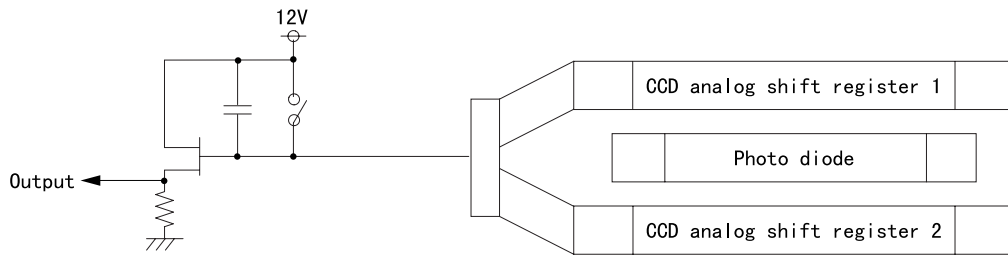

The /RS signal is the reset signal of the CCD output signal. The CCD output is expressed as electric charges equivalently accumulated in the capacitor. Therefore, to take the CCD output data one pixel by one pixel, one output data must be cleared after it is outputted. The /RS signal is used for that operation.

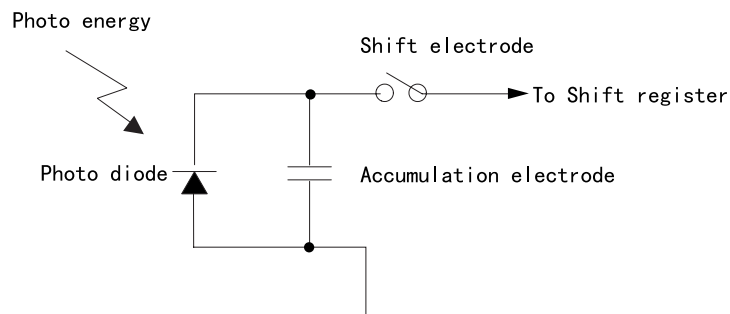

The /SP pulse signal is the peak hold signal of the signal voltage.

The output signal from the CCD is amplified by about 4.7 times greater in the differential amplifier circuit in the CCD PWB.

Differential amplification is made for the signal output (OS) and the compensation output (DOS).

The amplified CCD signal output is sent to the clamp circuit. In the clamp circuit, the black level is clamped to 2V at the BCLK signal timing by the analog switch. The clamped voltage is maintained for one line by the coupling capacitor. The clamped analog signal is impedance-converted and inputted to the AD convertor.

The analog signal inputted to the AD convertor is converted into 8bit digital data and passed to the PCU PWB.

The machine employs the TCD1501C as the image sensor. The TCD1501C is the reduction type high sensitivity CCD linear sensor of one-output system. 5000 pixels of 7 $\mu$ m x 7 $\mu$ m are arranged in line to allow scanning of A3 document at 400dpi (16 lines/mm).

[14] CIRCUIT DIAGRAM

BLOCK DIAGRAM

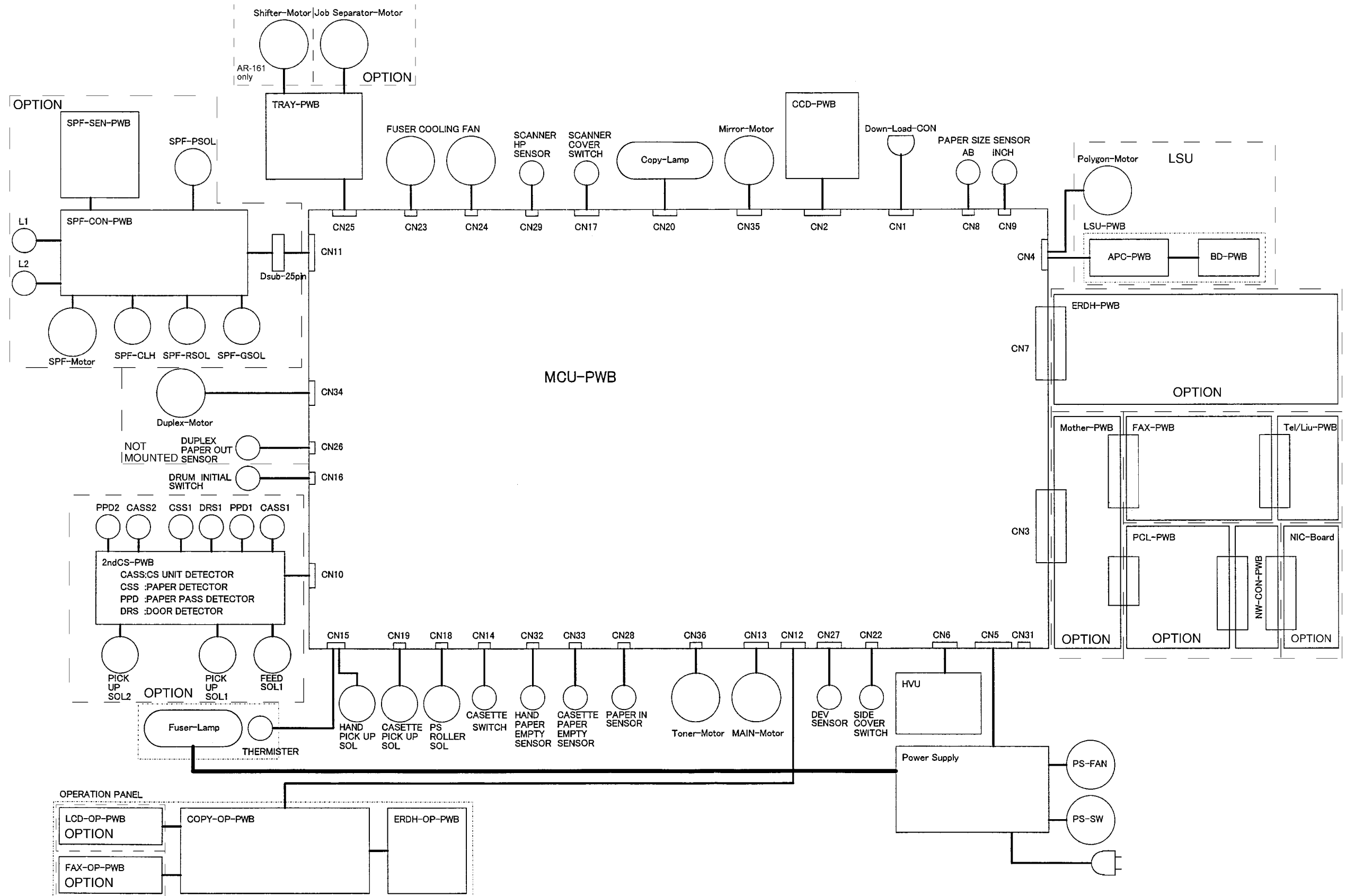

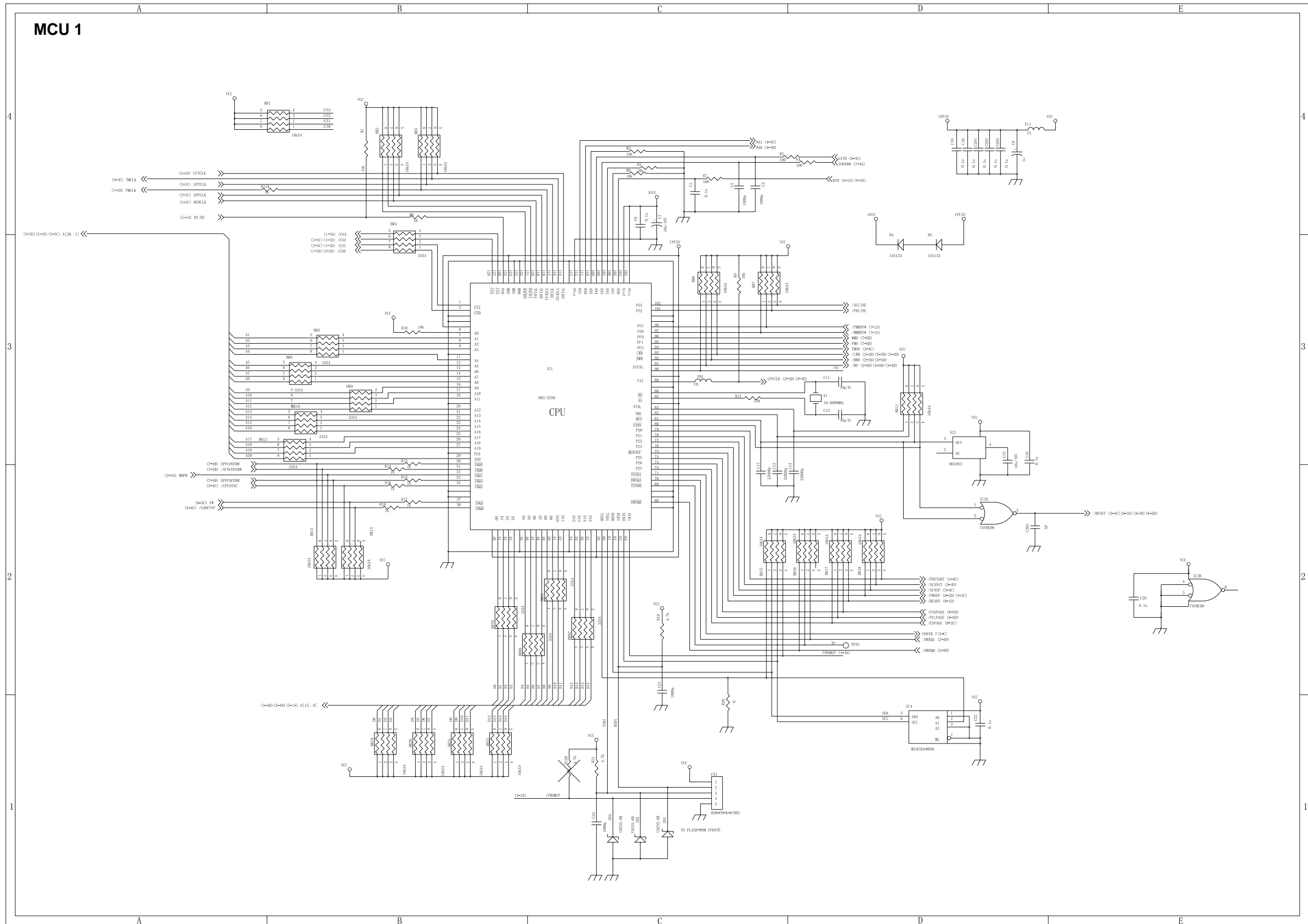

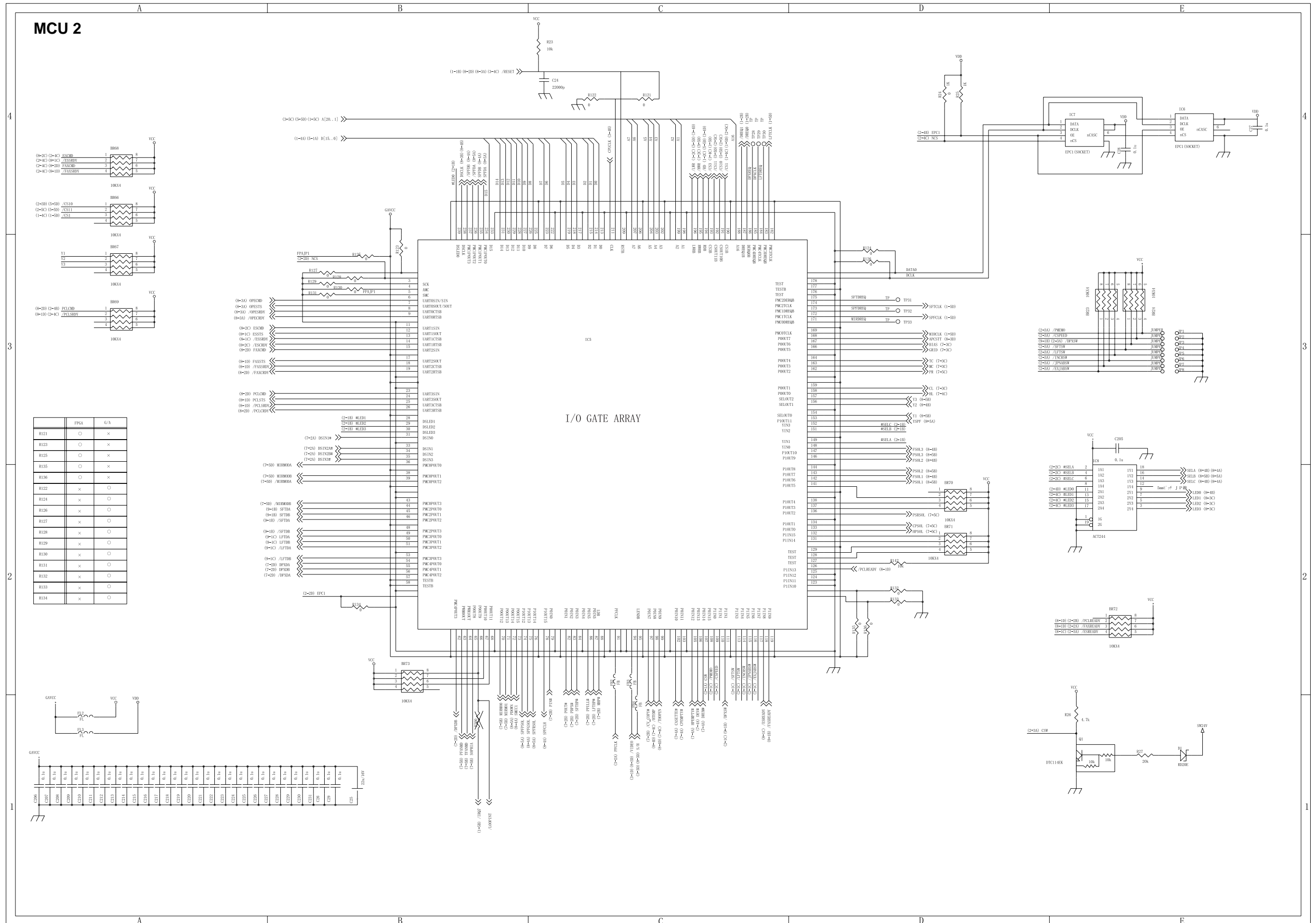



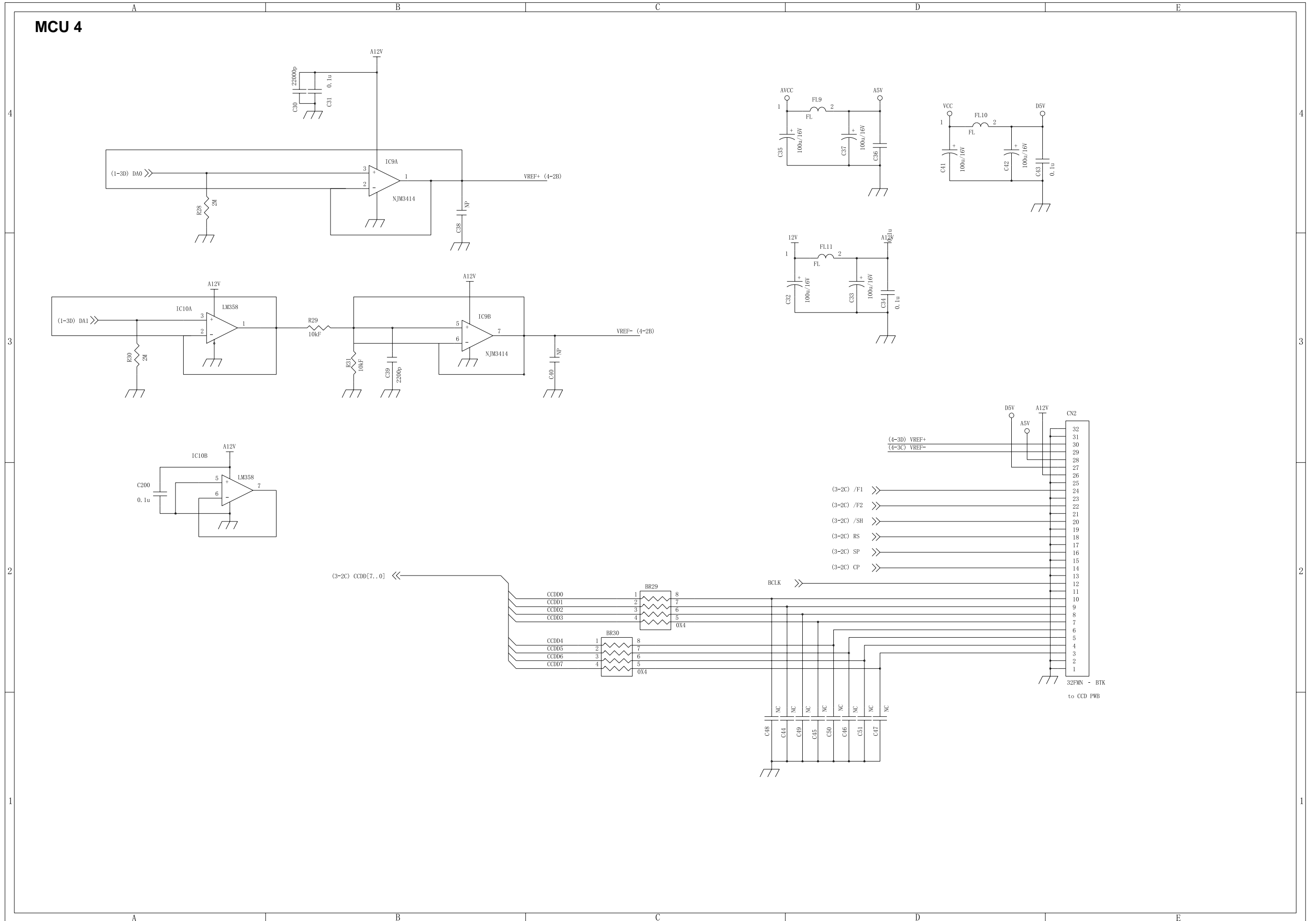



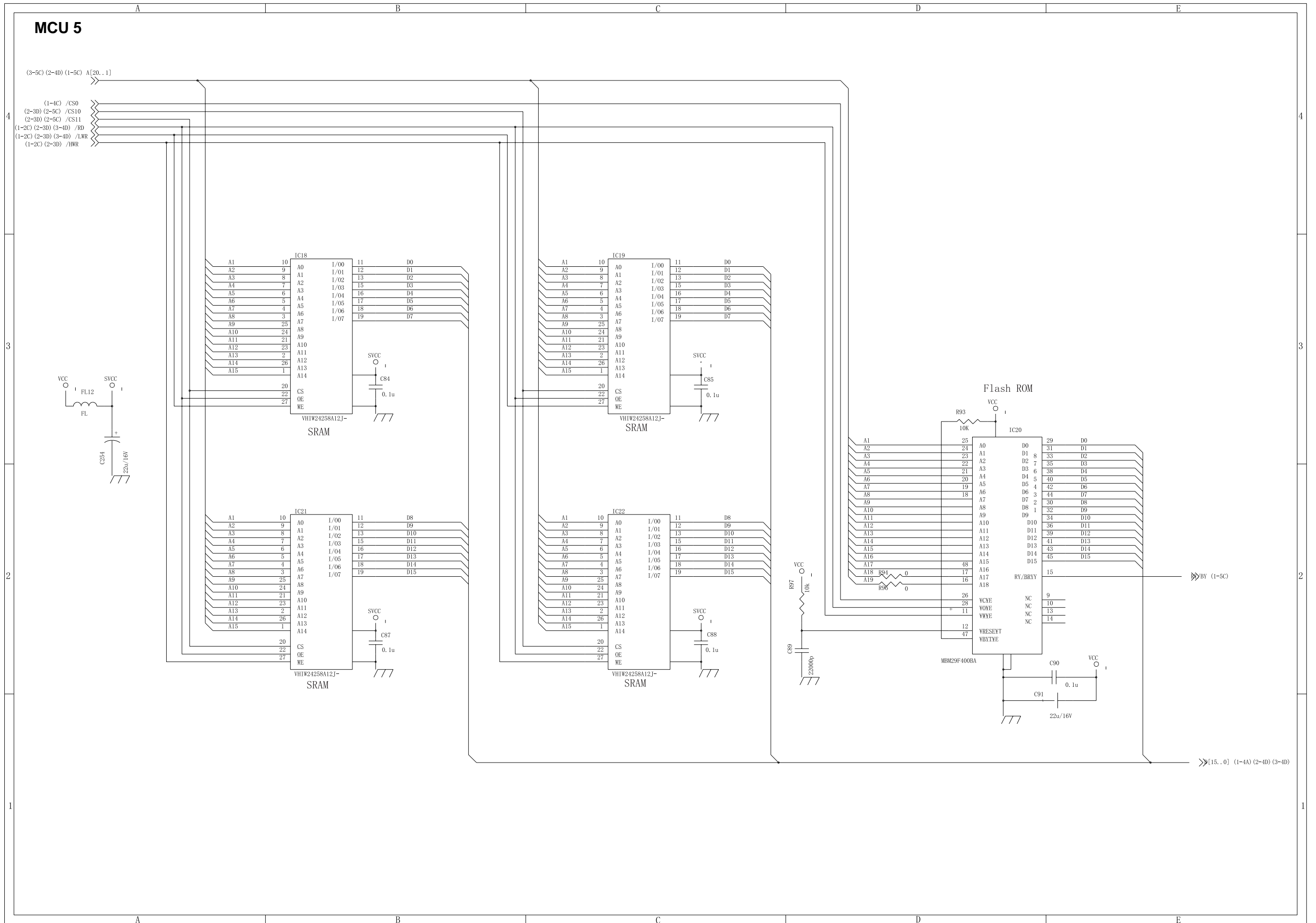

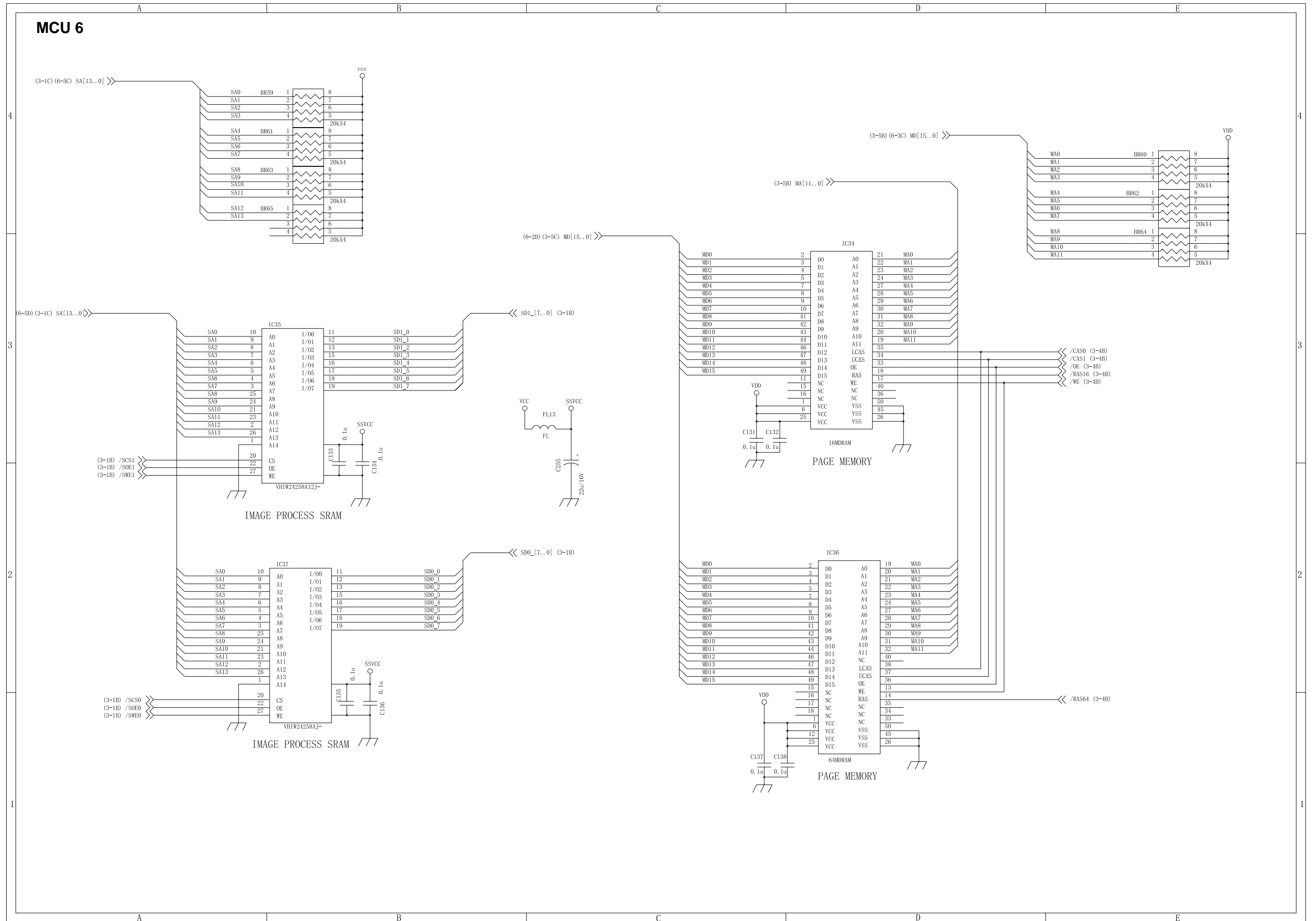

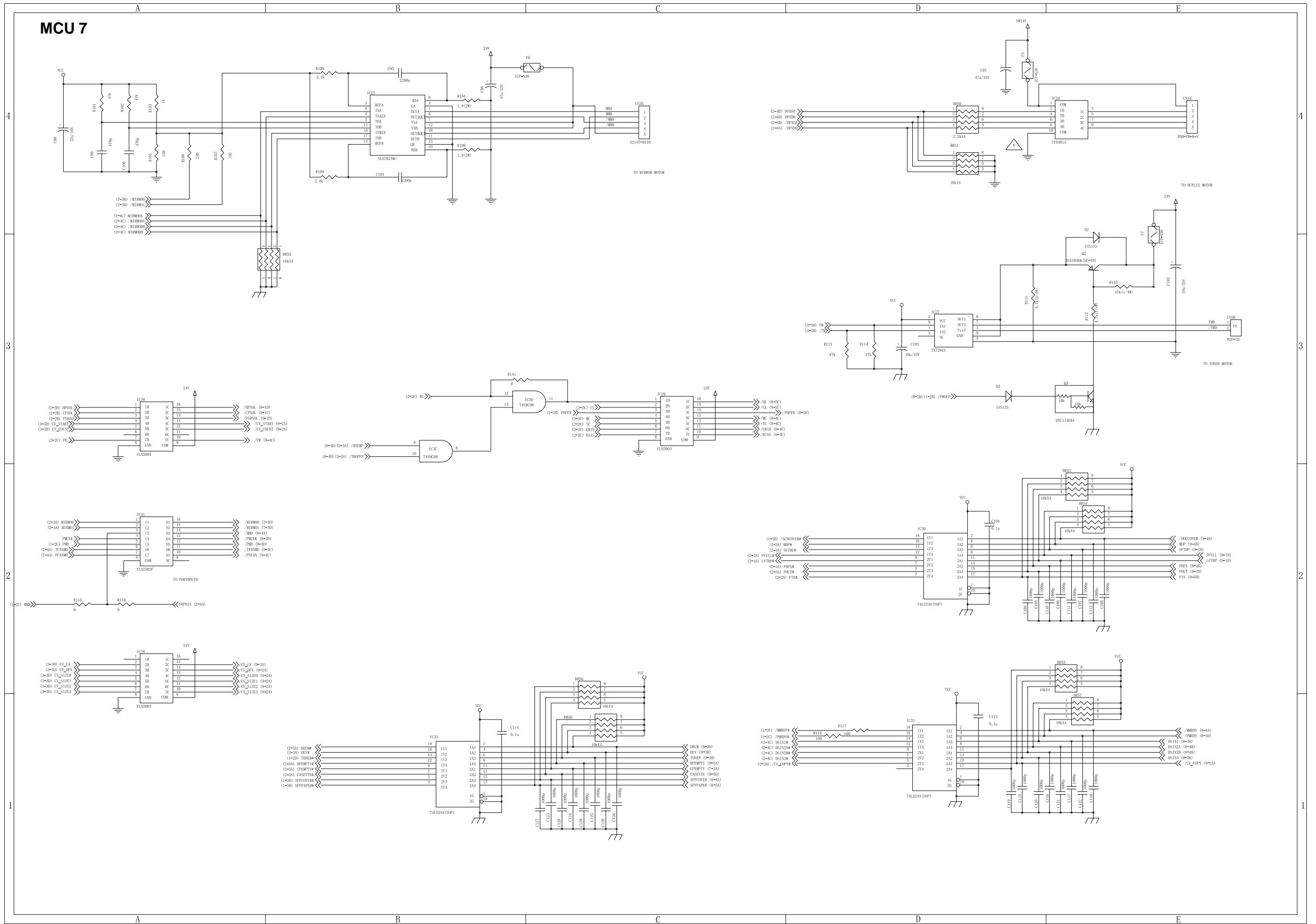

# MCU 8

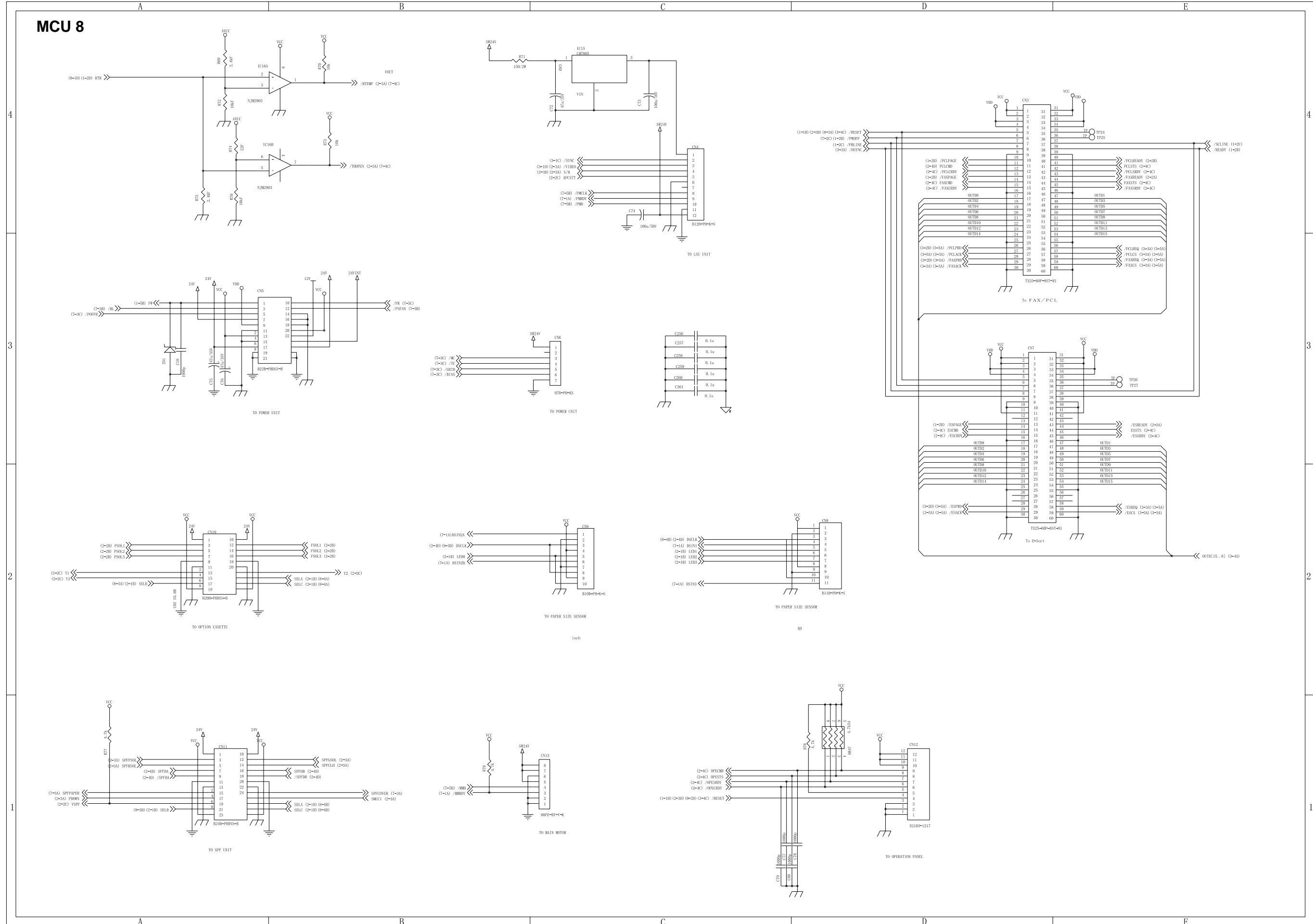

MCU 9

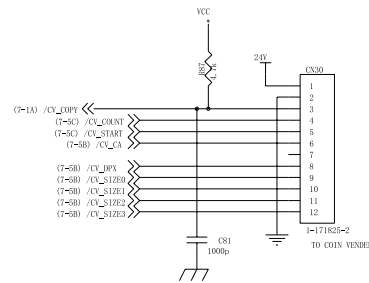
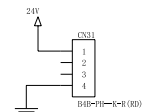
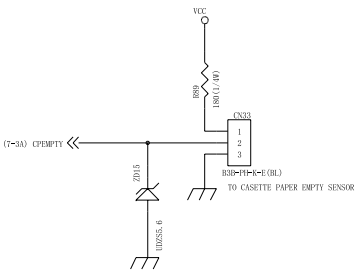
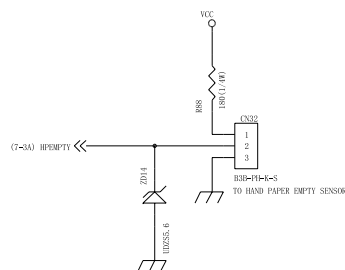
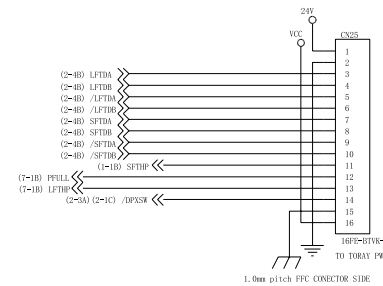
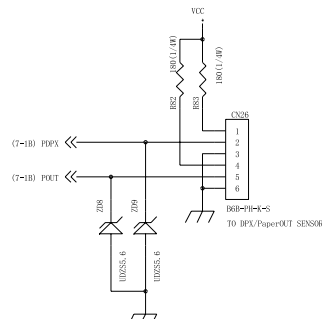
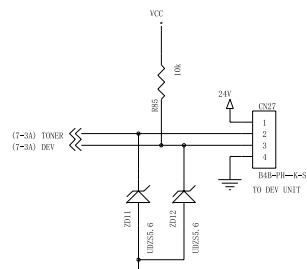
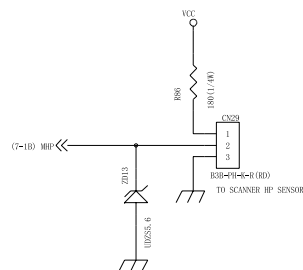
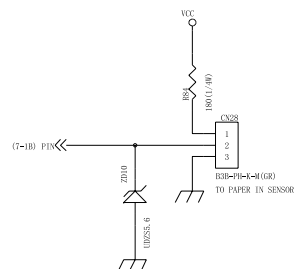
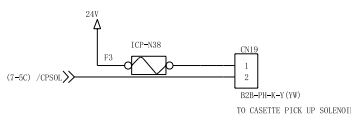
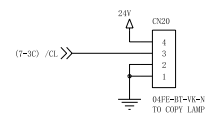
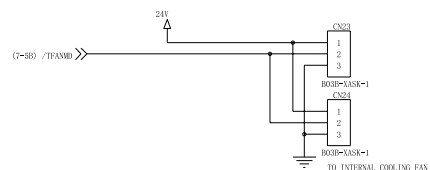
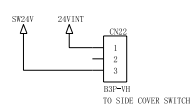
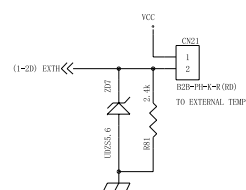
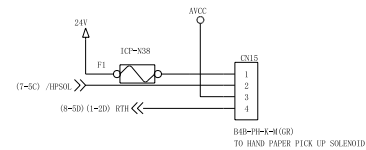
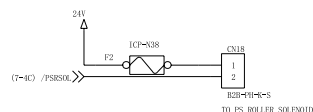
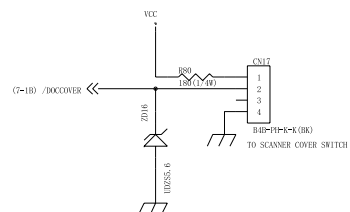
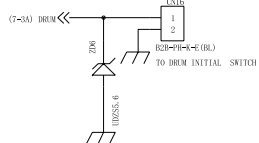
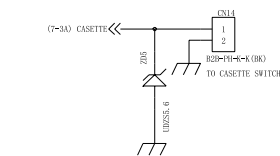

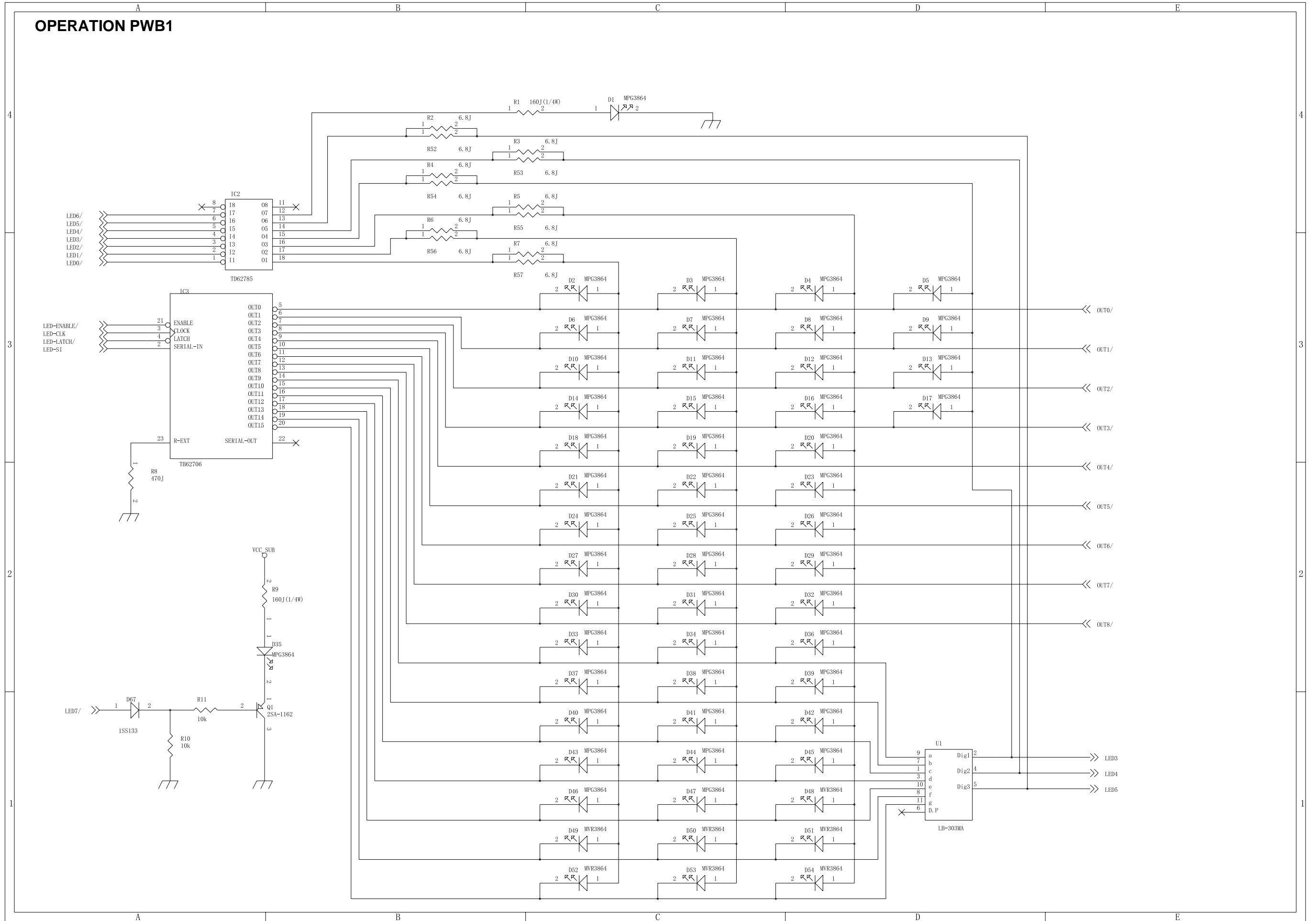

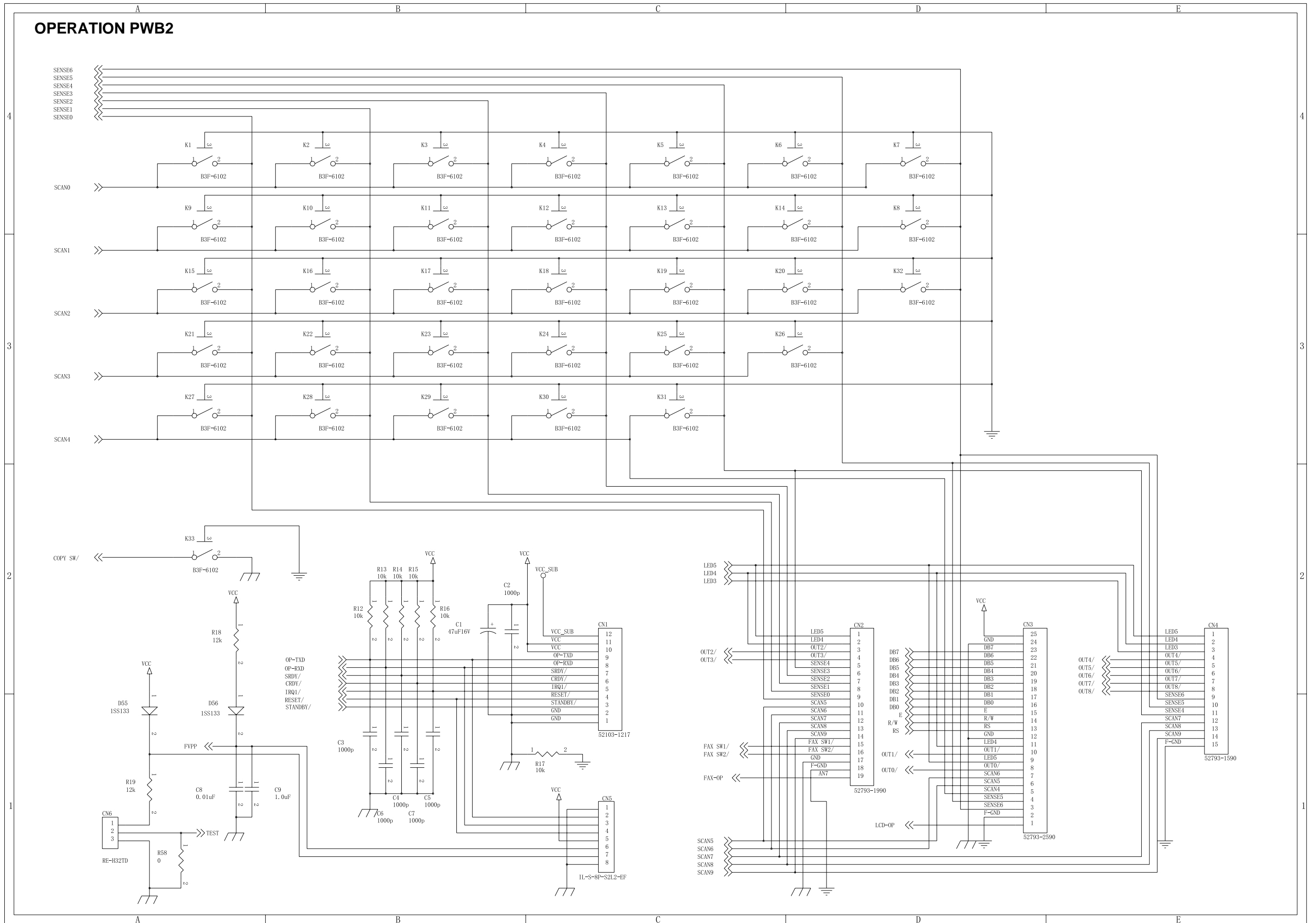

# OPERATION PWB3

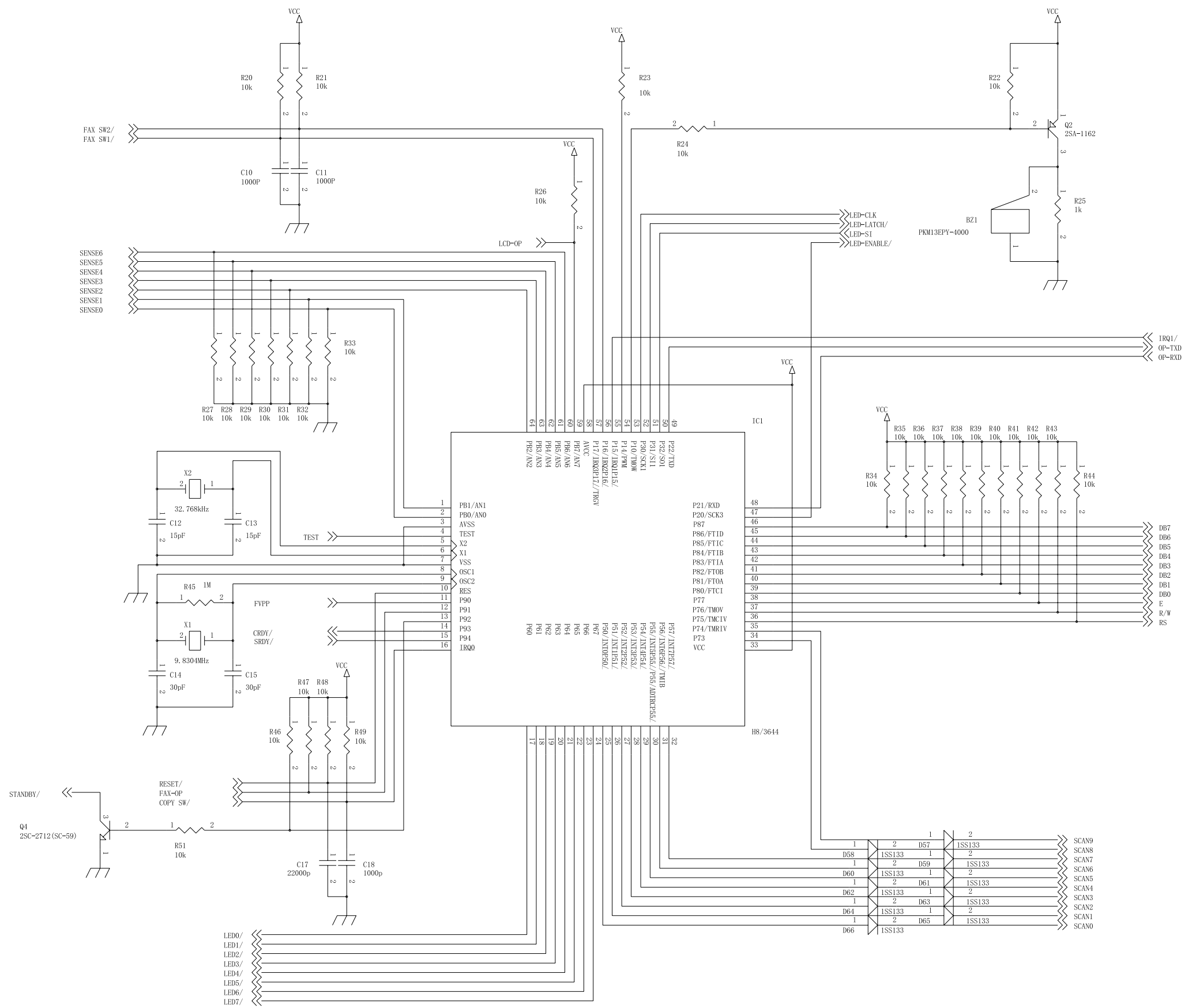



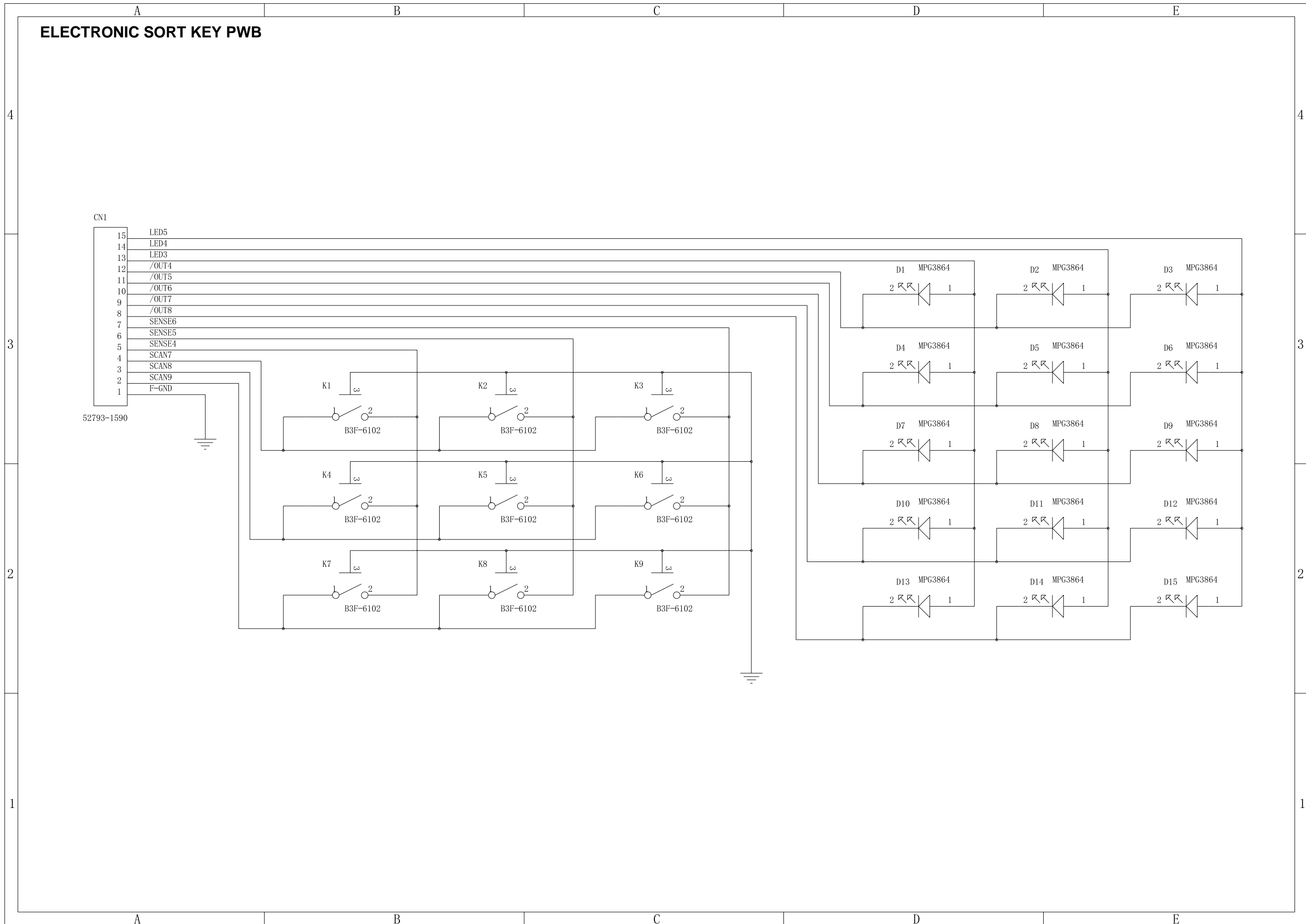

[15] ACTUAL WIRING DIAGRAM

ACTUAL WIRING DIAGRAM 1/3

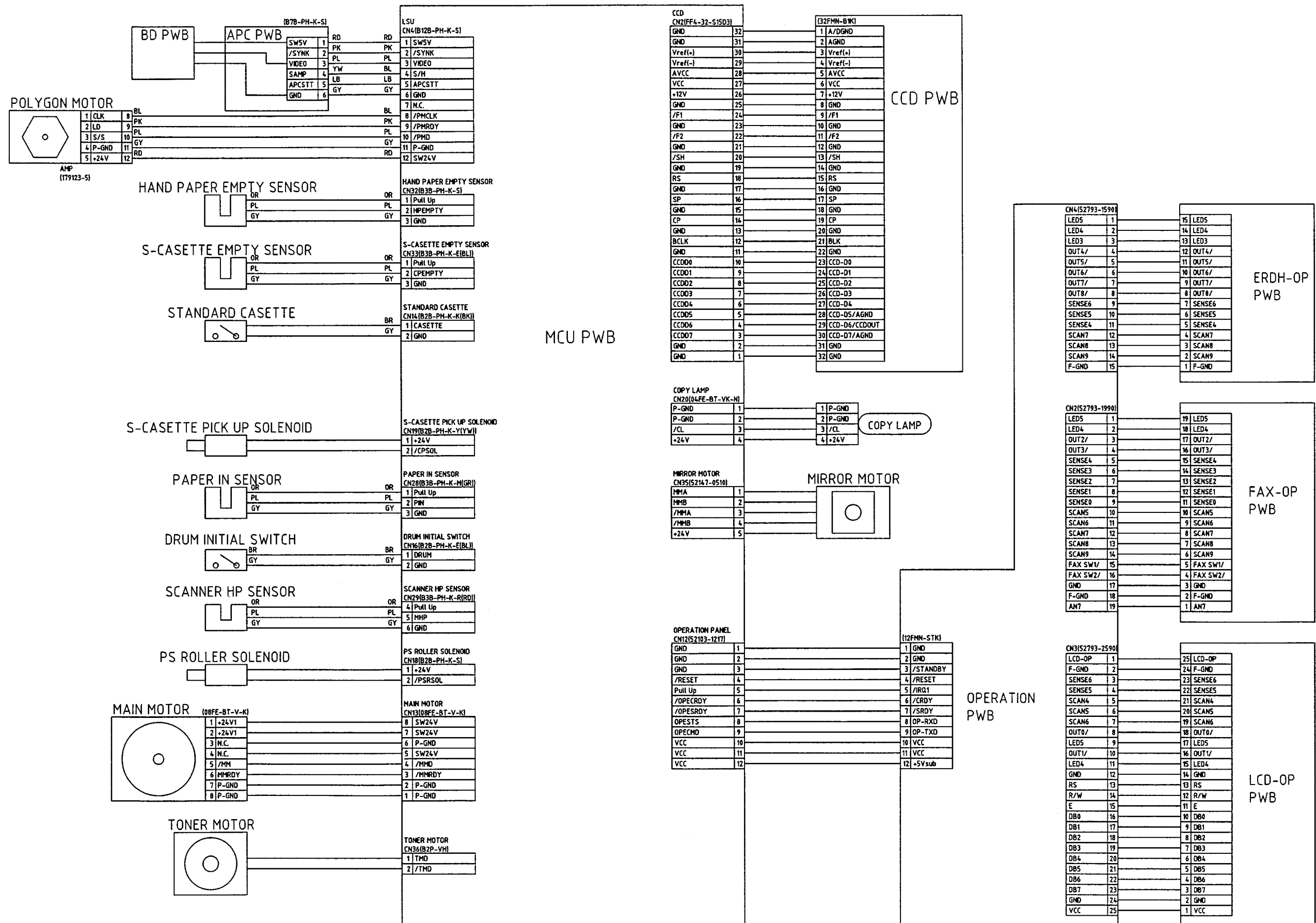

ACTUAL WIRING DIAGRAM 2/3

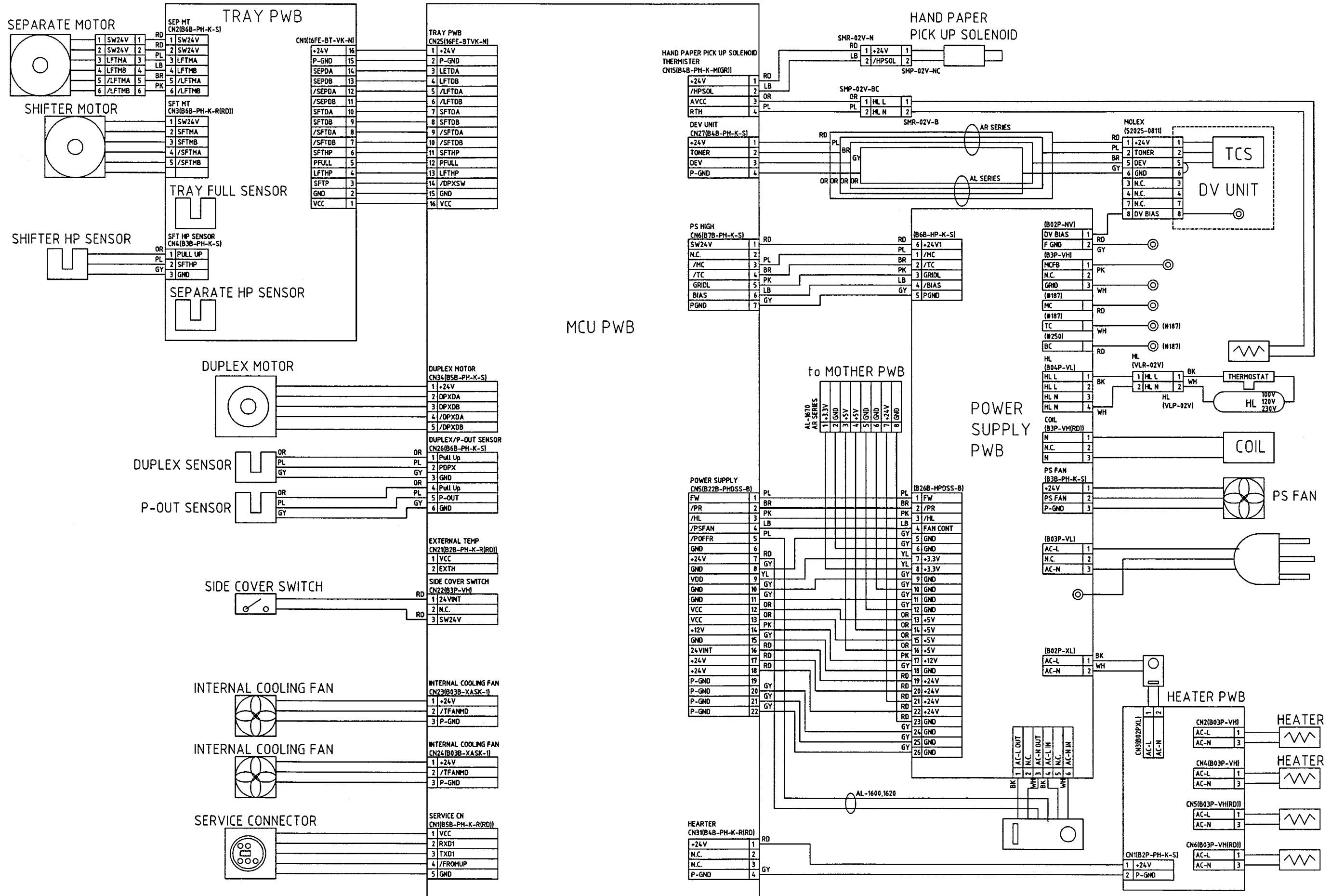

ACTUAL WIRING DIAGRAM 3/3

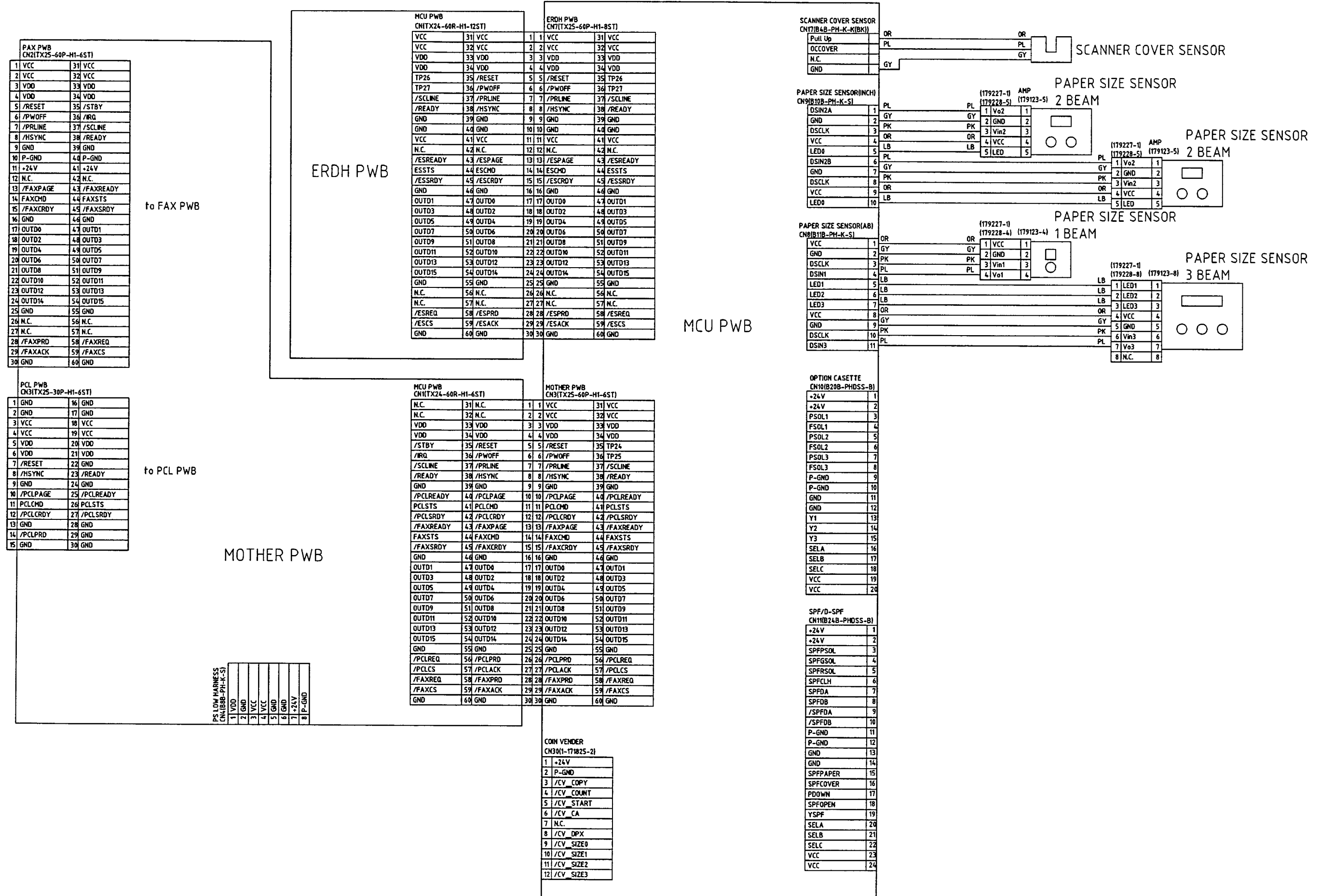



# SHARP

**COPYRIGHT © 1998 BY SHARP CORPORATION**

All rights reserved.

Printed in Japan.

No part of this publication may be reproduced,  
stored in a retrieval system, or transmitted,  
in any form or by any means,  
electronic, mechanical, photocopying, recording, or otherwise,  
without prior written permission of the publisher.

**SHARP CORPORATION**  
**Printing & Reprographic Systems Group**  
**Quality & Reliability Control Center**  
**Yamatokoriyama, Nara 639-1186, Japan**

1998 December Printed in Japan ㊞