

SEARS

099
owner's
manual

**MODEL NO.
247.886510**

315-550-099

85
319-550-099
1989

CAUTION:

Read
INSTRUCTIONS
carefully

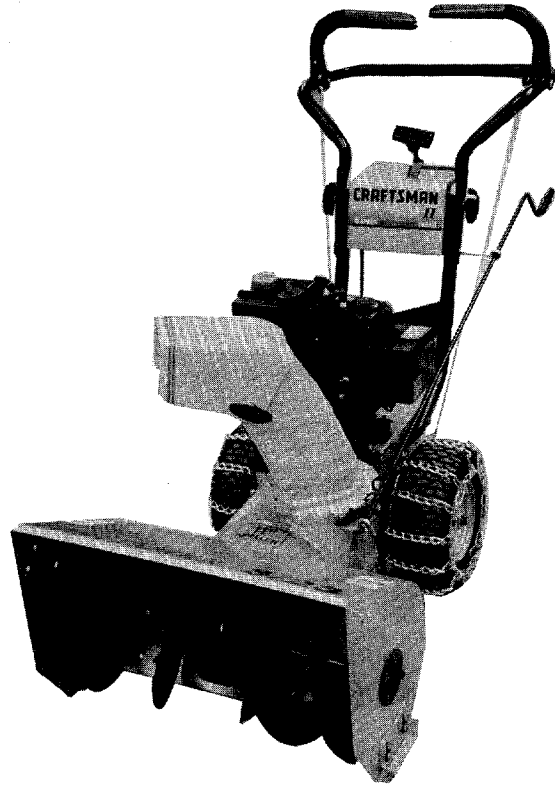

SEARS / CRAFTSMAN®

**23" - 5 H.P. DUAL STAGE
SNOW THROWER**
Optional Electric Starter Available

- Assembly
- Operation
- Maintenance
- Repair Parts

Sold by Sears, Roebuck and Co., Chicago, IL 60684

CRAFTSMAN WARRANTY

LIMITED TWO YEAR WARRANTY ON CRAFTSMAN SNOW THROWER

For two years from the date of purchase, when this **Craftsman Snow Thrower** is maintained, lubricated and tuned up according to the instructions in the owner's manual, Sears will repair, free of charge, any defect in material and workmanship.

If this **Craftsman Snow Thrower** is used for commercial or rental purposes, this warranty applies for only 90 days from the date of purchase.

This warranty does not cover: Expendable items which become worn during normal use, such as spark plugs, tire chains and shear pins.

Repairs necessary because of operator abuse or negligence, including bent crankshafts and the failure to maintain the equipment according to the instructions contained in the owner's manual.

WARRANTY SERVICE IS AVAILABLE BY CONTACTING THE NEAREST SERVICE CENTER/DEPARTMENT IN THE UNITED STATES. This warranty applies only while this product is in use in the United States.

This warranty gives you specific legal rights, and you may also have other rights which vary from state to state.

SEARS, ROEBUCK AND CO.

DEPT. 698/731A

SEARS TOWER

CHICAGO, IL 60684

OWNER'S INFORMATION

Record the following information about your unit so that you will be able to provide it in case of loss or theft.

DATE PURCHASED: _____ MODEL NO./CODE: 247.886510/_____

STORE WHERE PURCHASED: ADDRESS: _____

CITY: _____ STATE: _____ TELEPHONE: _____

MAINTENANCE AGREEMENT

A SEARS MAINTENANCE AGREEMENT IS AVAILABLE FOR THIS PRODUCT. CONTACT YOUR NEAREST SEARS STORE FOR DETAILS.

TABLE OF CONTENTS

	Page		Page
CRAFTSMAN WARRANTY	2	STORAGE	14, 15
OWNER'S INFORMATION	2	ADJUSTMENT/REPAIRS	15-19
MAINTENANCE AGREEMENT	2	TROUBLE SHOOTING GUIDE	20
SAFE OPERATION PRACTICES	3	SNOW THROWER REPAIR PARTS	22-29
ASSEMBLY INSTRUCTIONS	4-9	ENGINE REPAIR PARTS	30-34
OPERATING INSTRUCTIONS	10-13	HOW TO ORDER REPAIR PARTS ..	Back Cover
MAINTENANCE	13, 14		

IMPORTANT

SAFE OPERATION PRACTICES FOR WALK-BEHIND SNOW THROWERS



THIS SYMBOL POINTS OUT IMPORTANT SAFETY INSTRUCTIONS WHICH, IF NOT FOLLOWED COULD ENDANGER THE PERSONAL SAFETY AND/OR PROPERTY OF YOURSELF AND OTHERS. READ AND FOLLOW ALL INSTRUCTIONS IN THIS MANUAL BEFORE ATTEMPTING TO OPERATE YOUR SNOW THROWER.



To reduce the potential for any injury, comply with the following safety instructions. Failure to comply with the instructions may result in personal injury.

TRAINING

1. Read this owner's guide carefully. Be thoroughly familiar with the controls and proper use of the equipment. Know how to stop the unit and disengage the controls quickly.
2. Never allow children to operate equipment. Never allow adults to operate equipment without proper instructions.
3. No one should operate this unit while intoxicated or while taking medication that impairs the senses or reactions.
4. Keep the area of operation clear of all persons, especially small children and pets.
5. Exercise caution to avoid slipping or falling, especially when operating in reverse.

PREPARATION

1. Thoroughly inspect the area where the equipment is to be used and remove all door mats, sleds, boards, wires and other foreign objects.
2. Disengage all clutches and shift into neutral before starting engine.
3. Do not operate equipment without wearing adequate winter outer garments. Wear footwear which will improve footing on slippery surfaces.
4. Check the fuel before starting the engine. Gasoline is an extremely flammable fuel. Do not fill the gasoline tank indoors, while the engine is running, or while the engine is still hot. Replace gasoline cap securely and wipe off any spilled gasoline before starting the engine as it may cause a fire or explosion.
5. Use a grounded three wire plug-in for all units with electric drive motors or electric starting motors.
6. Adjust auger housing height to clear gravel or crushed rock surface.
7. Never attempt to make any adjustments while engine is running (except where specifically recommended by manufacturer).
8. Let engine and machine adjust to outdoor temperature before starting to clear snow.
9. Always wear safety glasses or eye shields during operation or while performing an adjustment or repair, to protect eyes from foreign objects that may be thrown from the machine in any direction.

OPERATION

1. Do not put hands or feet near rotating parts. Keep clear of discharge opening at all times.
2. Exercise extreme caution when operating on or crossing gravel drives, walks, or roads. Stay alert for hidden hazards or traffic. Do not carry passengers.
3. After striking a foreign object, stop the engine, remove wire from spark plug, and thoroughly inspect the snow thrower for any damage. Repair the damage before restarting and operating the snow thrower.
4. If the snow thrower should start to vibrate abnormally, stop the engine and check immediately for the cause. Vibration is generally a warning of trouble.

5. Stop engine whenever you leave the operating position, before unclogging the auger/impeller housing or discharge guide, and making any repairs, adjustments, or inspections.
6. Take all possible precautions when leaving the unit unattended. Disengage the auger/impeller, shift into neutral, stop the engine, and remove the key.
7. When cleaning, repairing, or inspecting, make certain auger/impeller and all moving parts have stopped. Disconnect spark plug wire and keep away from plug to prevent accidental starting.
8. Do not run engine indoors, except when starting engine and transporting snow thrower in or out of building. Open doors. Exhaust fumes are dangerous.
9. Do not clear snow across the face of slopes. Exercise extreme caution when changing direction on slopes. Do not attempt to clear steep slopes.
10. Never operate snow thrower without guards, plates, or other safety protection devices in place.
11. Never operate snow thrower near glass enclosures, automobiles, windows wells, drop offs, etc., without proper adjustment of snow thrower discharge angle. Keep children and pets away.
12. Do not overload machine capacity by attempting to clear snow at too fast a rate.
13. Never operate the machine at high transport speeds on slippery surfaces. Look behind and use care when backing.
14. Never direct discharge at bystanders or allow anyone in front of unit.
15. Disengage power to auger/impeller when transporting or not in use.
16. Use only attachments and accessories approved by the manufacturer of snow thrower (such as wheel weights, counterweights, cabs, etc.).
17. Never operate the snow thrower without good visibility or light. Always be sure of your footing and keep a firm hold on the handles. Walk, never run.

MAINTENANCE AND STORAGE

1. Check shear bolts, engine mounting bolts, etc., at frequent intervals for proper tightness to be sure equipment is in safe working condition.
2. Never store the machine with fuel in the fuel tank inside a building where ignition sources are present, such as hot water and space heaters, clothes dryers, and the like. Allow engine to cool before storing in any enclosure.
3. Always refer to owner's manual instructions for important details if snow thrower is to be stored for an extended period.
4. Maintain or replace safety and instruction labels, as necessary.
5. Run machine a few minutes after throwing snow to prevent freeze up of auger/impeller.

ASSEMBLY INSTRUCTIONS

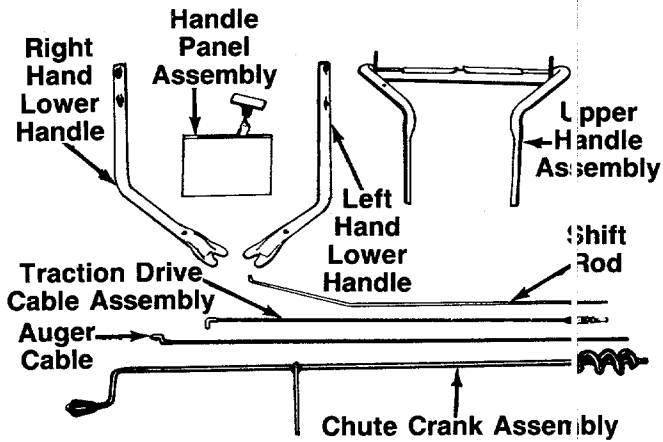

FIGURE 1.

NOTE

Reference to right and left side of the snow thrower is from the operator's position at the handle.

TOOLS REQUIRED FOR ASSEMBLY

- 1 Knife (to cut carton)
- 2 1/2" Wrenches (or Adjustable Wrenches)
- 1 Pair of Pliers
- 1 9/16" Wrench (or Adjustable Wrench)
- 1 7/16" Wrench (or Adjustable Wrench)

CONTENTS OF SHIPPING CARTON (See figure 1)

- 1. Snow Thrower (not shown)
- 2. Lower Handles—R.H. and L.H.
- 3. Handle Panel Assembly
- 4. Upper Handle Assembly
- 5. Traction Drive Cable Assembly
- 6. Auger Cable
- 7. Parts taped together which include:
 - Shift Rod
 - Chute Crank Assembly
- 8. Hardware Pack (plastic bag) which contains the hardware shown in figure 2 (shown actual size), plus one chute crank bracket and two ignition keys which are not shown.
- 9. Tire Chains (not shown)

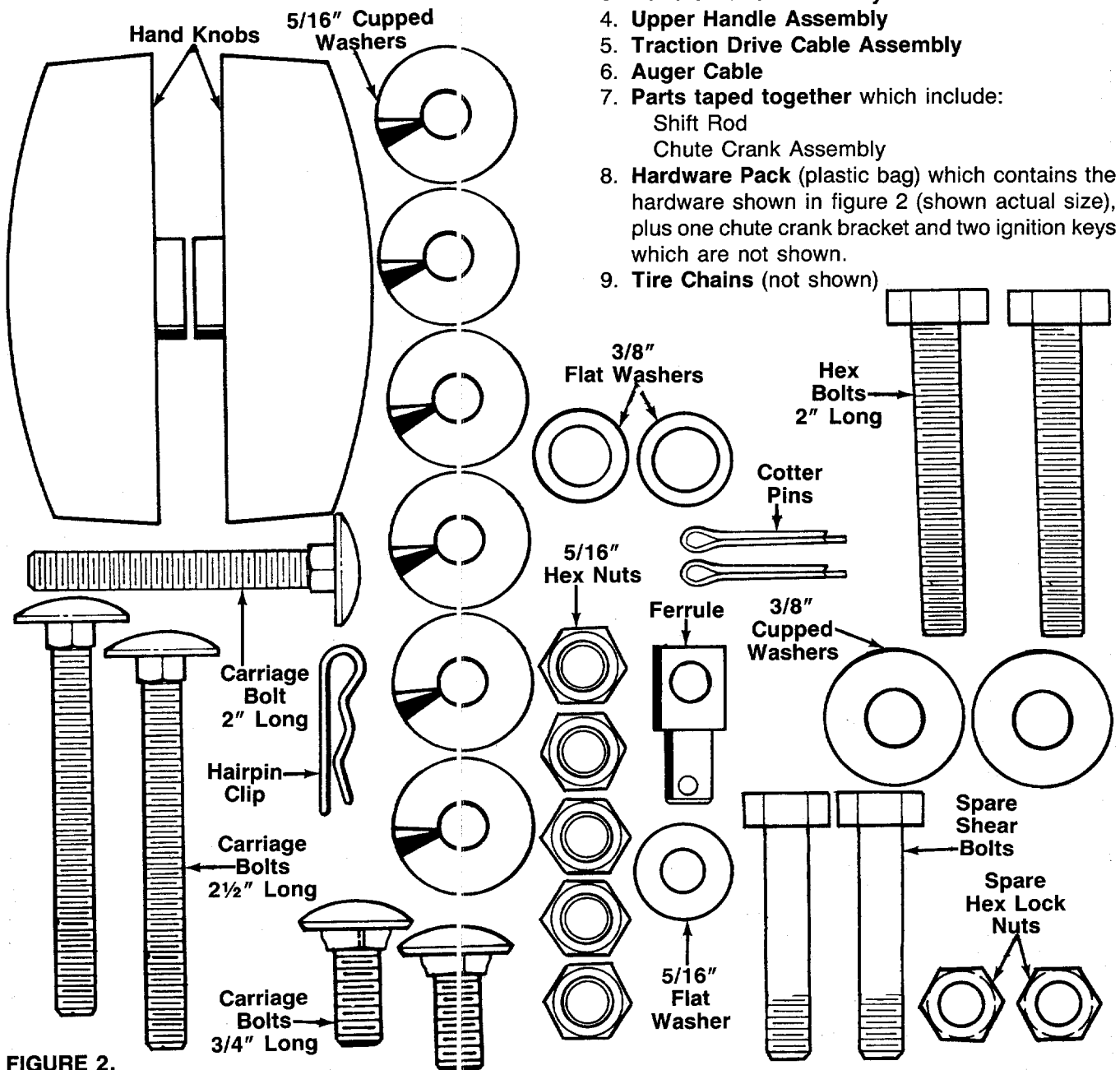

FIGURE 2.

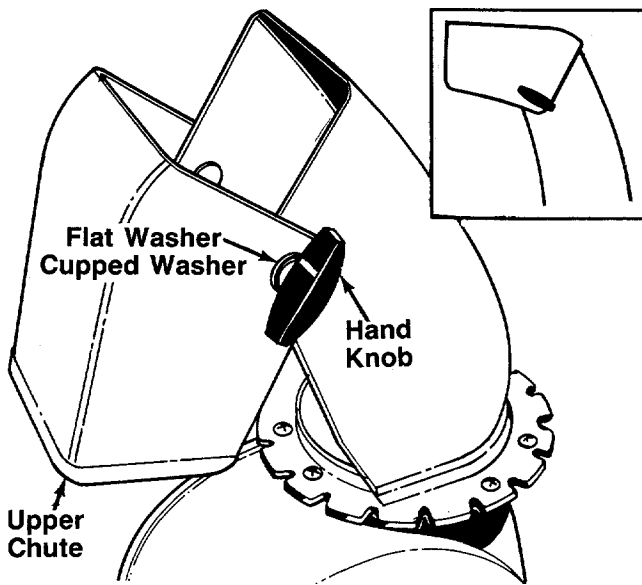

FIGURE 3.

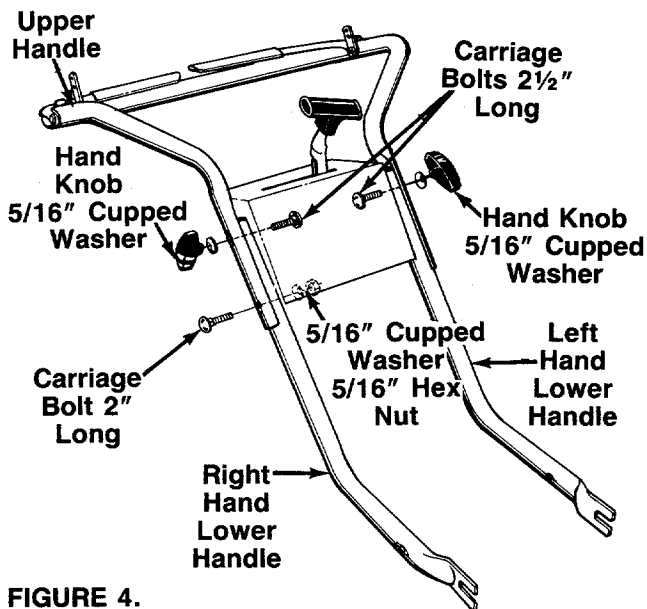

FIGURE 4.

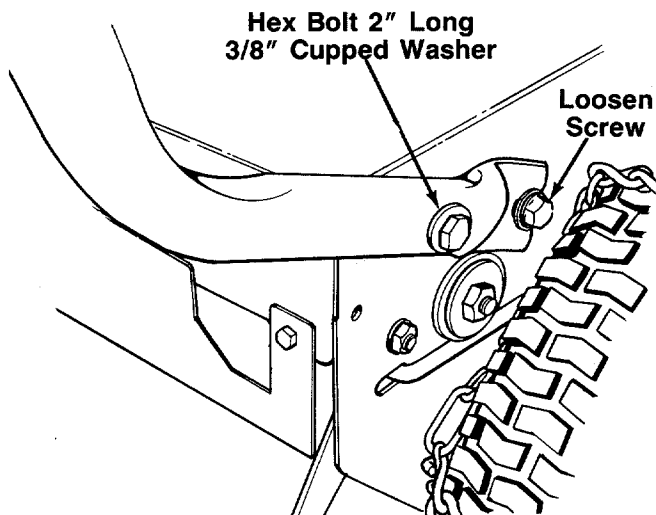

FIGURE 5.

UNPACKING

1. Cut the four corners of the carton from top to bottom. Lay the panels flat on the ground.
2. Remove all packing inserts. Make certain all loose parts and literature have been removed before discarding the inserts or carton.
3. Pull the snow thrower out of the carton.

ATTACHING THE UPPER CHUTE

The snow thrower has been shipped with the upper chute pivoted all the way down for shipping purposes.

← See figure 3.

1. Remove the hand knob, cupped washer, flat washer and carriage bolt from the upper chute.
2. Pivot the upper chute up so there is no gap between the upper and lower chute. See figure 3, inset. Secure with hardware just removed.

ASSEMBLING THE HANDLE

← 1. Preassemble the upper and lower handles to the handle panel as shown in figure 4.

- A. Secure the top holes in the upper and lower handles to the handle panel using two carriage bolts 2 1/2" long, 5/16" cupped washers and hand knobs. The head of the carriage bolts is on the inside of the handle panel. Cupped side of washers go against the upper handle. Do not tighten the hand knobs at this time.
- B. Secure the lower hole in the right hand side of upper and lower handles to the handle panel using carriage bolt 2" long, 5/16" cupped washer and hex nut. The head of the carriage bolt is on the outside of the handle. Cupped side of washer goes against the handle panel. Do not tighten at this time.
- C. Leave lower hole on left side of upper and lower handles and handle panel open.

NOTE

All three bolts go through both the upper and lower handles.

2. Attach the handle assembly to the unit as follows.
 - A. Loosen one self-tapping screw and cupped washer on each side of the unit. See figure 5. A 9/16" or adjustable wrench is required.
 - B. Slide the slotted end of the handles under the cupped washers.
 - C. Secure the upper hole in the handles with 3/8" cupped washers and 2" long hex bolts. Cupped side of washers go against the handles. Do not tighten at this time.

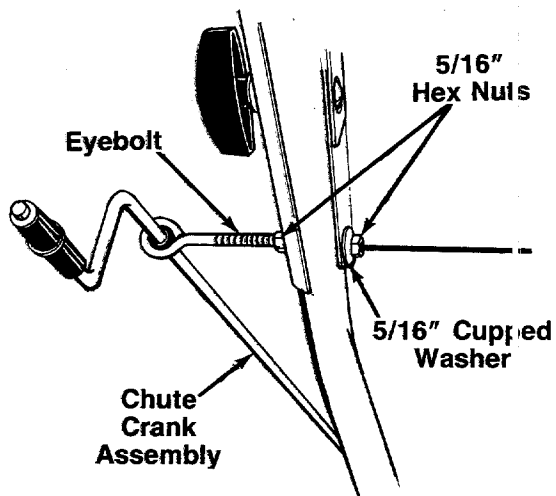

INSTALLING THE CHUTE CRANK ASSEMBLY

1. Attach the chute crank assembly to the handle and handle panel as follows.
 - A. Thread one 5/16" hex nut about halfway onto the eyebolt on the chute crank assembly.
 - B. Insert the eyebolt through the lower hole in the left hand side of upper and lower handles and handle panel. See figure 6. Secure with 5/16" cupped washer (cupped side of washer goes against the handle panel) and 5/16" hex nut. Do not tighten at this time.
2. Tighten securely all bolts and nuts on the handle panel (except the eyebolt) and all four bolts which secure the handles to the frame.

FIGURE 6.

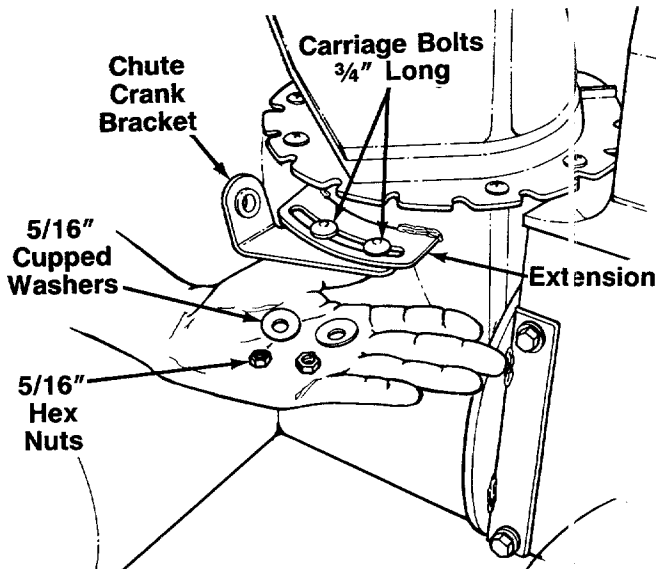

3. Rotate the discharge chute so the opening is facing the front of the snow thrower.
4. Attach chute crank bracket to the extension on the left side of the chute opening (bracket goes beneath the extension) as shown in figure 7. Secure with two 3/4" long carriage bolts, 5/16" cupped washers (cupped side of washers go against the chute bracket) and hex nuts. Do not tighten at this time.

FIGURE 7.

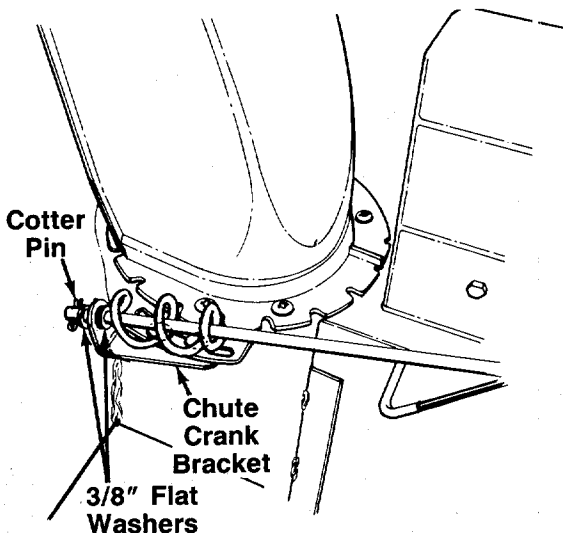

5. Place one 3/8" flat washer on the end of the chute crank assembly. Insert the end of the crank into the plastic bushing in the chute crank bracket. See figure 8.

NOTE

If necessary, adjust the hex nuts on the eyebolt so the chute crank does not touch the engine.

6. Place the other 3/8" flat washer on the end of the chute crank, and insert the cotter pin into the hole in the end of crank. Secure by bending the ends of the cotter pin in opposite directions.
7. Adjust the chute crank bracket so the spirals on the chute crank fully engage the notches on the chute. Tighten the hex nuts to secure the bracket in this position.
8. Tighten the hex nuts on the eyebolt at the handle panel.

FIGURE 8.

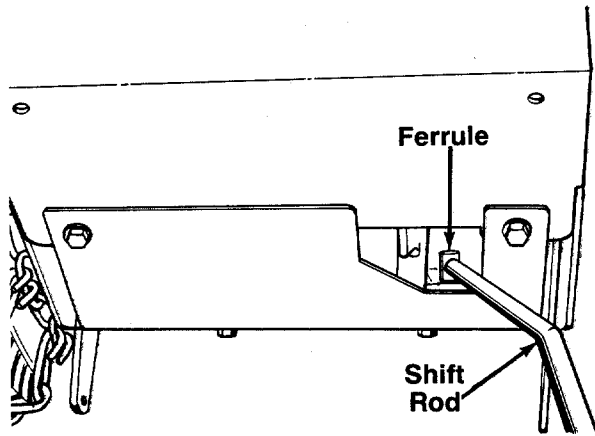

FIGURE 9.

ATTACHING THE SHIFT ROD

1. Place the threaded end of the shift rod inside the back cover plate. See figure 9. Thread rod part-way into ferrule. ←

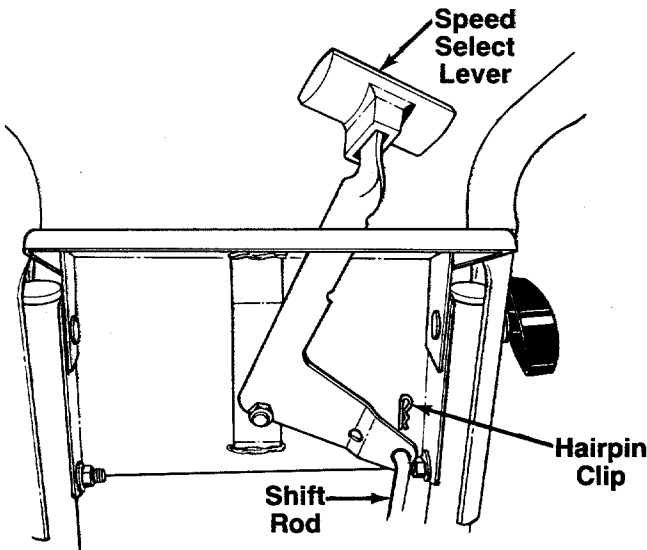

FIGURE 10.

2. Place the speed select lever in sixth speed (6) position. See figure 10. Push the shift rod down as far as it will go, to put the gears into full forward position. Thread the shift rod in or out of the ferrule as necessary until the end of the rod lines up with the hole in the speed select lever. ←
3. Insert end of rod into hole in speed select lever. Secure with hairpin clip. See figure 10.

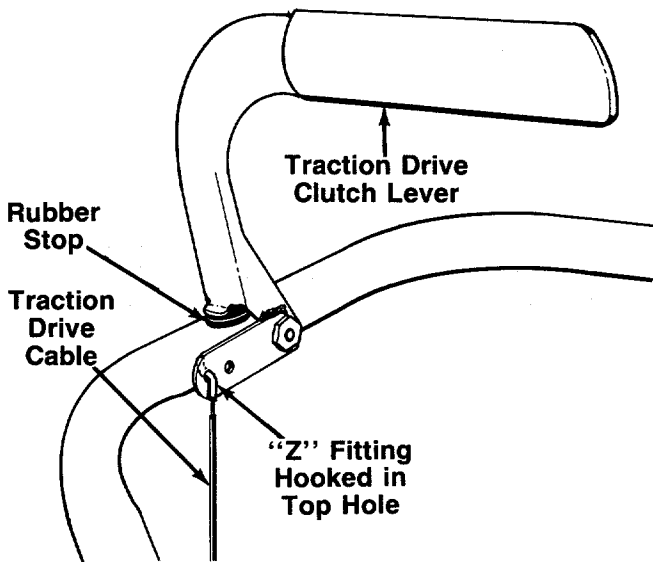

FIGURE 11.

ATTACHING THE TRACTION DRIVE CABLE

The traction drive cable is the cable which has the spring attached to one end. Attach the traction drive cable as follows.

1. Hook the "Z" fitting on the end of the cable into top hole in the traction drive clutch lever (right hand side of handle). Hook the fitting from the inside as shown in figure 11. ←

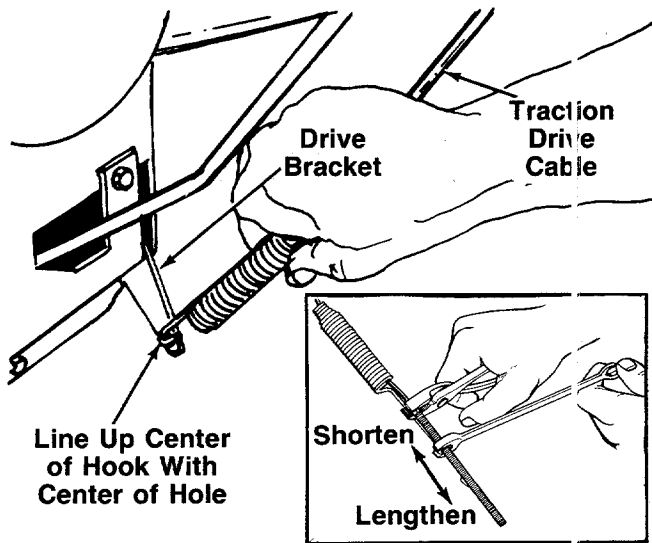

FIGURE 12.

2. Raise the clutch lever so it is just touching the rubber stop on the handle. See figure 11. With the clutch lever in this position, swing the traction drive cable down and simply hold it beside the drive bracket. **Do not pull on spring. Do not move bracket. The hook on the end of the spring must line up with the center of the hole in the drive bracket.** See figure 12.

If it does not, adjust the nut on the cable by sliding the spring up and using a 7/16" wrench and pliers to move the nut on the end of the cable up or down as necessary until the hook on the spring aligns with the center of the hole in the bracket. See figure 12, inset.

NOTE

Do not place the pliers on the threaded part of the cable.

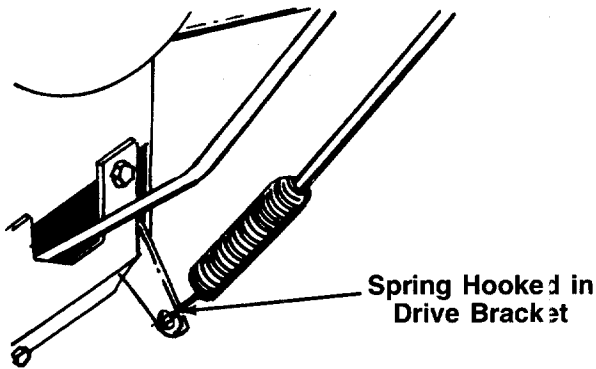

FIGURE 13.

3. Hook the traction drive cable into the drive lever. **There should not be any tension on the spring when the clutch lever is in the released position (up) position.** See figure 13.

To check the adjustment, push the clutch lever down against the handle. The drive bracket should move up. Release the clutch lever. Drive bracket should return to the neutral (down) position, and the clutch lever should spring up, away from the handle.

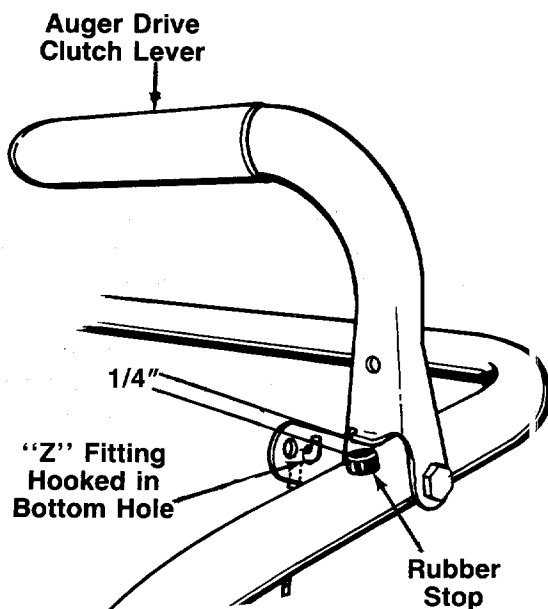

FIGURE 14.

ATTACHING THE AUGER CABLE

1. Hook the "Z" fitting on the end of the auger cable into the bottom hole in the auger drive clutch lever (left hand side of handle). Hook the fitting from the inside to the outside as shown in figure 14.

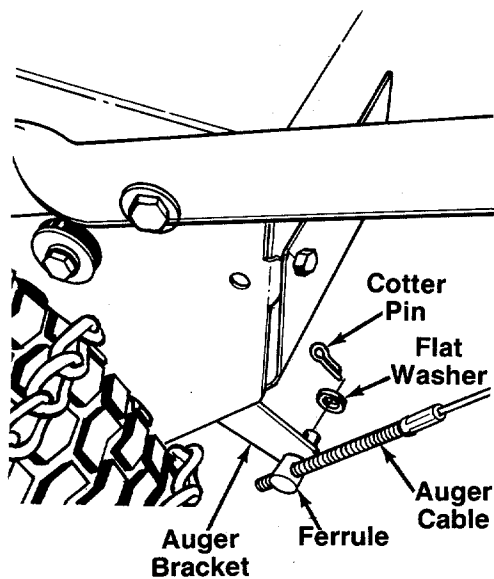

FIGURE 15.

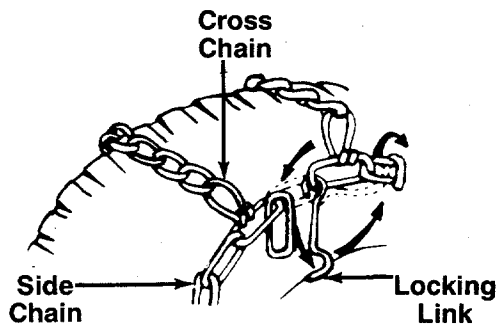

FIGURE 16.

2. Raise the clutch lever so it is approximately 1/4" away from the rubber stop on the handle, as shown in figure 14. With the clutch lever in this position, thread the ferrule onto the end of the auger cable until it lines up with the hole in the auger bracket.

← See figure 15.

3. Insert the ferrule into the auger bracket as shown in figure 15. Secure with 5/16" flat washer and cotter pin, bending the ends of the cotter pin in opposite directions.

To check the adjustment, push the clutch lever down against the handle. The auger bracket should move up. Release the clutch lever. Auger bracket should return to the neutral (down) position, and the clutch lever should spring up, away from the handle. If further adjustment is needed, refer to the Repairs/Adjustments section of this manual.

TIRE PRESSURE

The tires are overinflated for shipping purposes. Check the tire pressure, and reduce to 15 to 20 psi. The tire pressure must be equal in both tires.

TIRE CHAIN INSTALLATION

Attach the tire chains to the wheels as follows. See figure 16.

1. Tip the snow thrower up on the front end. Have someone hold it in this position to prevent tipping as you install the chains.
2. Lay chain over tire so the open hook ends of cross chains are away from the tire. The locking link must be on the outside of tire.
3. Center the chains on the tire. Hook the ends of the side chains on the inside of the tire.
4. Straighten the cross links, and pull chains tight. Attach the outside chain ends by inserting the locking link through the end of the side chain. (If chains are too loose, move up one link.) Then hook the locking link over the side chain as shown.

Repeat procedure on other side of snow thrower. Return the snow thrower to the operating position after chains are installed.

NOTE

If side chains appear to be too short and cannot be hooked, check for kinks in chain. Straighten chain and repeat installation procedure.

Chains may loosen after use. Check and tighten if necessary after using snow thrower.

FINAL ADJUSTMENTS

Before operating the snow thrower, adjust the skid shoes to accommodate the type of surface to be cleared. Refer to Skid Shoe Adjustment in Adjustments/Repairs section on page 15.

OPERATING INSTRUCTIONS



DANGER

1. STOP ENGINE BEFORE REMOVING DEBRIS AND SERVICING UNIT
2. KEEP CLEAR OF IMPELLER WHILE ENGINE IS RUNNING
3. NEVER DIRECT DISCHARGE AT BYSTANDERS OR WINDOWS OR ALLOW ANYONE IN FRONT OF UNIT
4. THOROUGHLY INSPECT THE AREA WHERE THE EQUIPMENT IS TO BE USED AND REMOVE ALL DOOR MATS, SLEDS, BOARDS, WIRES AND OTHER FOREIGN OBJECTS
5. REFER TO OWNERS MANUAL FOR FULL INSTRUCTIONS

ENGINE OPERATING CONTROLS

The engine operating controls and their functions are as follows (see figure 17):

Throttle Control Lever—Used to control speed of engine.

Choke Knob—Use FULL choke position to start a cold engine.

Primer Button—Used to inject fuel directly into the carburetor to insure fast starts in cold weather.

Ignition Key—Must be inserted into ignition key slot to start engine. Pull out to stop. Do not turn ignition key.

Starter Handle—Used to manually start the engine. An Electric Starter kit is available. See Engine Repair Parts section of this manual for kit number.

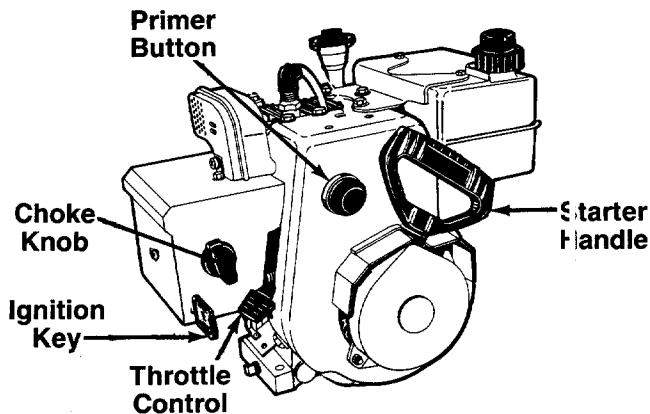

FIGURE 17.

SNOW THROWER OPERATING CONTROLS

The snow thrower operating controls and their functions are as follows (see figure 18):

Speed Select Lever—Located on the handle panel. The speed select lever allows the operator to use one of the six (6) forward speeds, neutral or two reverse speeds. The reverse (R) position closest to neutral (N) is the slower of the two reverse speeds. To shift, move the speed select lever to desired position.

NOTE

Release the traction drive clutch lever before shifting gears.

Traction Drive Clutch Lever—Located on the right handle, the traction drive clutch lever is used to propel the snow thrower forward or in reverse. Push lever down to engage; release lever to disengage.

Auger Drive Clutch Lever—Located on the left handle, the auger drive clutch lever is used to engage and disengage the auger and impeller. Push down to engage; release to disengage.

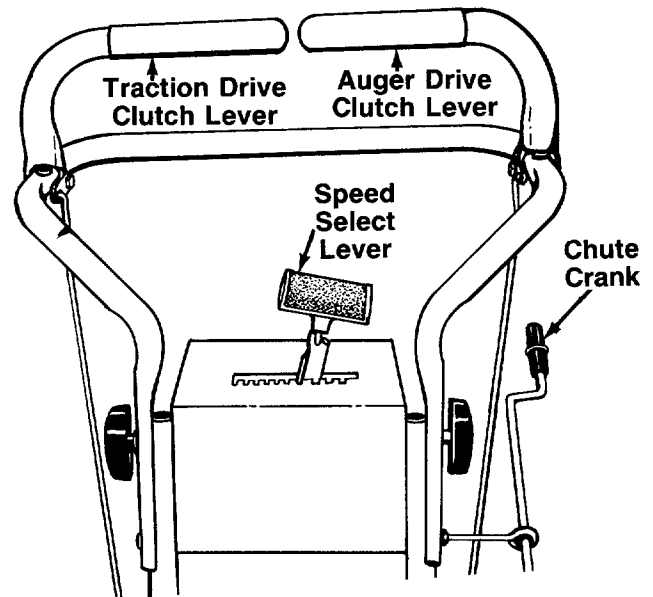

FIGURE 18.

Discharge Chute—The direction snow is thrown can be changed by turning the chute crank. See figure 19. Turn clockwise to discharge to the left. Turn counterclockwise to discharge to the right. The distance snow is thrown can be adjusted by raising the discharge chute for greater distance, or lowering for less distance. See figure 19. Loosen the hand knob on the side of the discharge chute to adjust. Pivot the chute to desired position, and retighten hand knob.

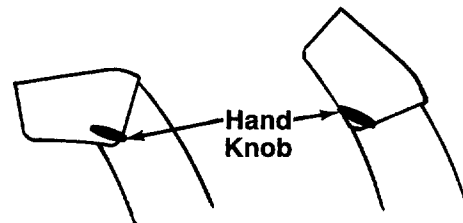

FIGURE 19.

Drive Wheels—The wheels may be adjusted for two different methods of operation. The adjustment is made by moving the "kwik" pin on the ends of the axle to one of two different positions.

1. Dual Wheel Drive—For heavy snow, insert the kwik pins into the wheel hubs for power drive to both wheels. See figure 20A.
2. Single Wheel Drive—Remove the kwik pin from the wheel hub on one side of the unit, and place in the outside hole in the axle. See figure 20B. This position allows power drive to one wheel only, making the unit easier to maneuver during transport. If traction while throwing snow becomes a problem, place kwik pin in Dual Wheel Drive position.

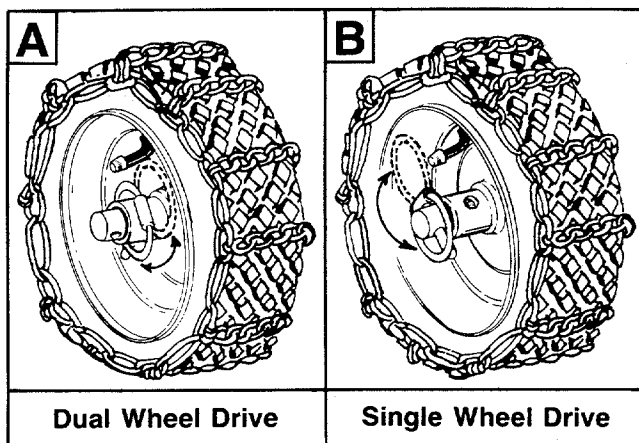

FIGURE 20.

TO SERVICE ENGINE

The engine on this snow thrower was shipped **without oil** in the crankcase. **Oil must be added before engine is started.**

1. Position snow thrower so engine is level. Remove oil fill cap and dipstick. See figure 21. Fill crankcase to FULL mark on dipstick (about 1-1/2 pints) with SAE 10W30 motor oil or equivalent. **Do not overfill.** Tighten fill cap and dipstick securely each time you check oil level. If temperature is consistently 20°F. or lower, SAE 5W30 motor oil may be substituted.
2. Fill fuel tank with clean, fresh, lead-free grade automotive gasoline.

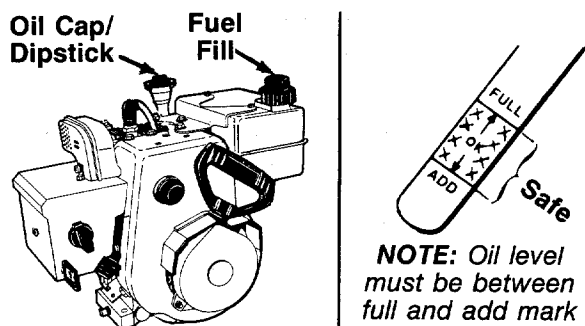

FIGURE 21.

Caution: Experience indicates that alcohol blended fuels (called gasohol or using ethanol or methanol) can attract moisture which leads to separation and formation of acids during storage. Acidic gas can damage the fuel system of an engine while in storage. To avoid engine problems, the fuel system should be emptied before storage for 30 days or longer. Drain the gas tank, start the engine and let it run until the fuel lines and carburetor are empty. Use fresh fuel next season. See Storage section of this manual for additional information.

Never use engine or carburetor cleaner products in the fuel tank or permanent damage may occur.



Never fill fuel tank indoors, when engine is running or while engine is still hot. Never fill fuel tank completely. Fill tank to within 1/4 to 1/2 inch from the top to provide space for expansion of fuel. Wipe up any spilled fuel before starting engine. Store gasoline in a clean, approved container.

3. Make certain the spark plug is tightened securely into engine, and spark plug wire is attached to spark plug. If torque wrench is available, torque plug to between 18 and 23 foot pounds.

TO START ENGINE

1. Make certain the auger and traction drive clutch levers are in the **disengaged** (released) position.
2. Move throttle control up to FAST position. Insert ignition key into slot. See figure 22. Be certain it snaps into place. **Do not turn key.**
3. Rotate choke knob to FULL choke position (cold engine start).
If engine is warm, place choke in OFF position instead of FULL.
4. Push primer button two or three times. See figure 22. If engine is warm, push primer button once only.

NOTE

Always cover vent hole in primer button with finger while pushing. Additional priming may be necessary for the first start if temperature is below 15°F.

5. Grasp starter handle (see figure 22) and pull rope out slowly, until it pulls slightly harder. Let rope re-wind slowly.

- Pull starter handle rapidly. Do not allow handle to snap back. Allow it to rewind slowly while keeping a firm hold on the starter handle.

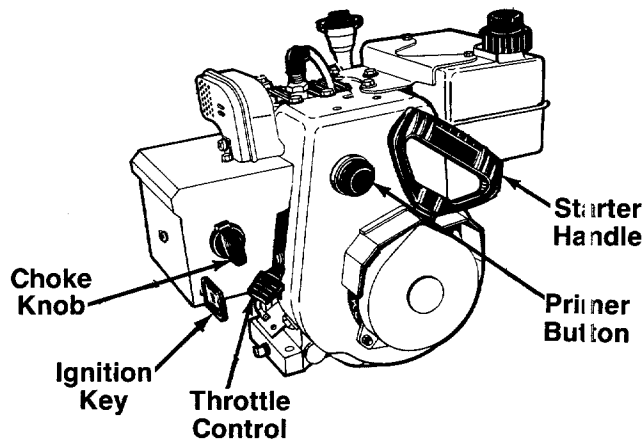

FIGURE 22.

NOTE

If recoil starter is frozen and will not crank the engine, proceed as follows:

- Pull as much rope out of the starter as possible.
- Release starter handle and let it snap back against the starter.

Only use the above procedure when necessary to free a frozen starter.

- Repeat steps 5 and 6 until engine starts. If engine fails to start, repeat steps 4, 5 and 6 until engine starts.
- As engine warms up and begins to operate evenly, rotate choke knob slowly to OFF position. If engine falters, return to FULL choke, then slowly move to OFF position.

NOTE

Allow the engine to warm up for a few minutes as the engine will not develop full power until it reaches operating temperature.



Temperature of muffler and surrounding areas may exceed 150°F. Avoid these areas.

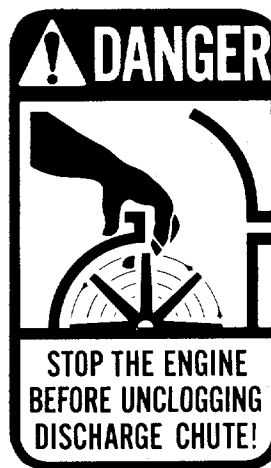

TO STOP ENGINE

- Run engine for a few minutes before stopping to help dry off any moisture on the engine.
- To help prevent possible freeze-up of starter, proceed as follows. With engine running, pull starter rope with a rapid, continuous full arm stroke three or four times. Pulling the starter rope will produce a loud clattering sound, which is not harmful to the engine or starter.
- To stop engine, remove the ignition key. Do not turn key. Disconnect the spark plug wire from the spark plug to prevent accidental starting while equipment is unattended.

NOTE

Do not lose ignition key. Keep it in a safe place. Engine will not start without the ignition key.

- Wipe all snow and moisture from the carburetor cover in the area of the control levers. Also, move control levers back and forth several times. Move throttle control lever to FAST and leave in this position. Move choke control to FULL choke position.

OPERATING THE SNOW THROWER

- Start the engine as instructed previously.
- Adjust the discharge chute up or down as desired. Then use the chute crank to position the discharge to discharge snow with the wind. Do not throw snow toward a building as hidden objects could be discharged with enough force to cause damage.
- With the traction drive clutch lever released, use the speed select lever to set desired speed. Use a slower ground speed for wet, heavy or deep snow. Reduce speed if the wheels slip. Operate the engine at full throttle for maximum efficiency.



WARNING

Be certain the traction drive clutch lever is released before moving the speed select lever.

4. Making certain no bystanders or obstacles are in front of the unit, engage the auger drive clutch lever (located on left handle).
5. Engage the traction drive clutch lever, located on the right handle. As the snow thrower starts to move, maintain a firm hold on the handle, and guide the snow thrower along the path to be cleared. Do not attempt to push the snow thrower.

To stop the forward motion, release the traction drive clutch lever. Release the auger drive clutch lever to stop the snow throwing action.

Operating Tips

1. For most efficient snow removal, remove snow immediately after it falls.
2. Discharge snow downwind whenever possible. Slightly overlap each previous swath.
3. Set the skid shoes 1/4" below the scraper bar for normal usage. The skid shoes may be adjusted upward for hard-packed snow. Adjust downward (raising the scraper bar) when using on gravel or uneven surfaces.
4. Be certain to follow the precautions listed under "To Stop Engine" on page 12 to prevent possible freeze-up.
5. Clean the snow thrower thoroughly after each use.

MAINTENANCE



WARNING

Disconnect the spark plug wire before performing any repairs or maintenance.

MAINTENANCE CHECK LIST	SERVICE RECORD						
	AFTER FIRST 2 HOURS BEFORE EACH USE	FREQUENTLY	EVERY 5 HOURS	EVERY 10 HOURS	EVERY 25 HOURS	BEGINNING EACH SEASON	BEFORE STORAGE
Check Engine Oil	•		•			•	
Change Engine Oil	•				•	•	
Tighten All Bolts and Nuts	•	•					
Check Adjustment of Auger Clutch						•	
Check Spark Plug				•	•		
Lubricate Shifting Mechanism & Chains			•			•	
Check Fuel	•						
Drain Fuel						•	

The Maintenance Check List is supplied to assist the operator in proper maintenance of the snow thrower. This is only a check list; instructions for adjustments will be found in the Adjustments/Repairs section of this manual.

Some adjustments will need to be made periodically to properly maintain your snow thrower.

All adjustments in Adjustments/Repairs section of this manual should be checked at least once a season. The following should be performed more than once each season.

All Bolts and Nuts—Should be checked often to make certain they are tight, preferably after each use.

Engine and Snow Thrower—Lubricate as instructed in the following section.

LUBRICATION

Engine Lubrication—Check Oil Level before starting engine and every 5 hours of operation. Oil level must be maintained between the “Full” and “Add” marks on dipstick. Refer to “To Service Engine” instructions on page 11.

Change Oil after first 2 hours of operation and every 25 hours thereafter. Change at least once a year if the snow thrower is not used for 25 hours.

To drain oil, position snow thrower so the oil drain plug is the lowest point on the engine. Remove oil drain plug and oil fill cap. See figure 23. Drain oil into a suitable container. Oil will drain more freely when warm.

Replace oil drain plug and tighten securely. Refill crankcase with SAE 10W30 motor oil. SAE 5W30 motor oil may be substituted when temperature is consistently 20°F. or lower.

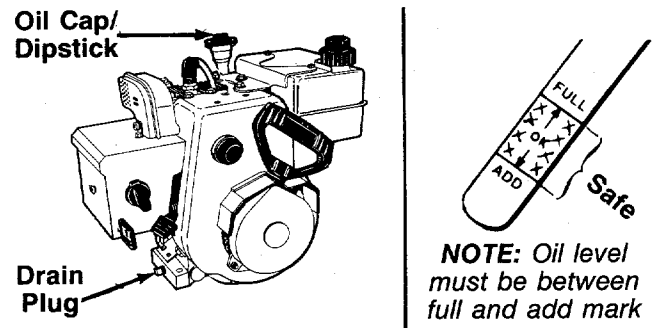

FIGURE 23.

Chains and Shifting Mechanism—Lubricate all chains, bearings, gears and the shifting mechanism with engine oil after every 10 hours of operation or at least once a season. See figure 24. Avoid getting oil on the friction wheel and drive plate.

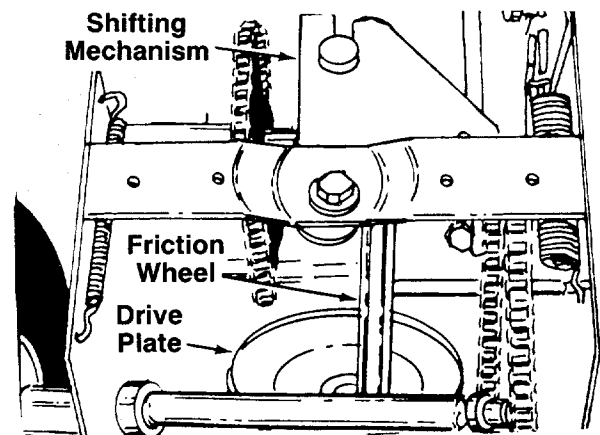

FIGURE 24.

STORAGE



Never store engine with fuel in tank indoors or in poorly ventilated enclosures, where fumes may reach an open flame, spark or pilot light such as on a furnace, water heater, clothes dryer, etc.

It is important to prevent gum deposits from forming in essential fuel system parts such as the carburetor, fuel hose or fuel tank during storage. Also, experience indicates that alcohol blended fuels (called gasohol or using ethanol or methanol) can attract moisture which leads to separation and formation of acids during storage. Acidic gas can damage the fuel system of an engine while in storage.

To avoid engine problems, the fuel system should be emptied before storage of 30 days or longer. Follow these instructions.

1. Run engine until fuel tank is empty and engine stops due to lack of fuel.
2. Disconnect fuel line at carburetor or fuel tank. Be careful not to damage fuel line, fittings or fuel tank. Drain any remaining fuel from the system.



Drain fuel into approved container outdoors, away from open flame.

NOTE

If gasohol has been used, complete the preceding instructions. Then put a small amount of unleaded (or regular) grade gasoline into fuel tank and repeat steps 1 and 2.

3. Change oil if it has not been changed recently. Refer to Maintenance section.
4. Remove the spark plug and squirt one ounce of clean engine oil into spark plug hole. Cover the

spark plug hole with a clean rag. Pull the starter rope slowly to allow the piston to coat the internal engine parts. Reinstall the spark plug. Do not connect spark plug wire.

5. Thoroughly clean the snow thrower. If unit is to be stored in an unventilated or metal storage shed, coat any metal parts with a light oil or silicone to prevent rust.

6. Store in a clean, dry area.

ADJUSTMENTS/REPAIRS



WARNING

Always stop engine and disconnect spark plug wire before performing any adjustments or repairs.

SKID SHOE ADJUSTMENT

The snow thrower is equipped with two adjustable skid shoes, located on each side of the auger housing. The skid shoes determine the distance between the scraper bar and the ground, which varies according to the type of surface to be cleared.

Normal, Hard Surfaces

When removing snow from a normal, hard surface such as a paved driveway or walk, the skid shoes should be adjusted to be approximately 1/4" lower than the scraper bar.

To adjust, proceed as follows.

1. Make certain both tires are inflated equally (15 to 20 psi), and that neither tire is resting on a link of the tire chains.
2. Place the threaded ends of the spare shear bolts (provided in hardware pack) under the scraper bar, one at each end. See figure 25.
3. Loosen the four hex nuts on the skid shoes. Push each skid shoe up or down until it touches the ground. Retighten the hex nuts securely.

Make certain the snow thrower is set at the same height on both sides, and the entire bottom surface of skid shoe is against the ground to avoid uneven wear.

Uneven or Rocky Surfaces

When removing snow from uneven, rocky or gravel surfaces, raise the scraper bar by moving the skid shoes down to avoid throwing gravel. Adjust as instructed above, using thicker objects under the scraper bar to act as spacers.

NOTE

Both the skid shoes and the shave plate are subject to wear and should be replaced when necessary.

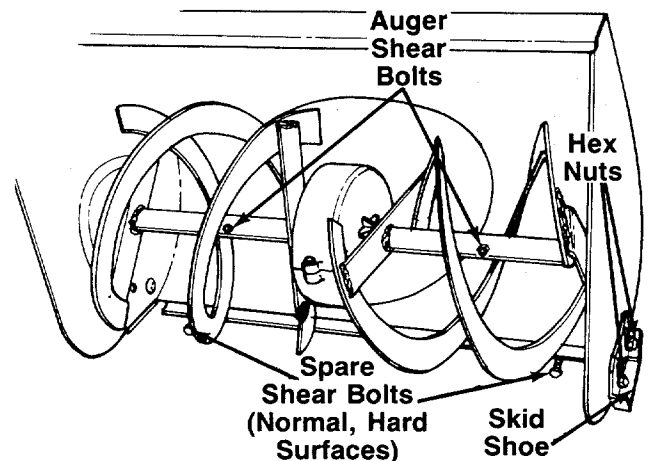

FIGURE 25.

SPEED SELECT LEVER ADJUSTMENT

If adjustment of the speed select lever is necessary, remove the hairpin clip which secures the shift rod to the speed select lever. Adjust as instructed under "Attaching the Shift Rod" in Assembly Instructions, page 7.

TRACTION DRIVE CLUTCH LEVER ADJUSTMENT

Periodic adjustment of the traction drive cable may be required due to normal wear on the friction wheel. If adjustment is necessary, unhook the spring on the end of the traction drive cable. Refer to figure 13. Adjust as instructed in steps 2 and 3 of "Attaching the Traction Drive Cable" in Assembly Instructions, page 8.

AUGER DRIVE CLUTCH LEVER ADJUSTMENT

The auger drive cable should be adjusted at least once a season. To adjust the auger cable, remove the ferule from the auger bracket by removing the cotter pin and flat washer. Refer to figure 15. Adjust as instructed in steps 2 and 3 of "Attaching the Auger Cable" in Assembly Instructions, page 9.

The auger drive cable adjustment can be checked as follows.

1. Remove the belt cover, which is held in place with four self-tapping screws. See figure 26.

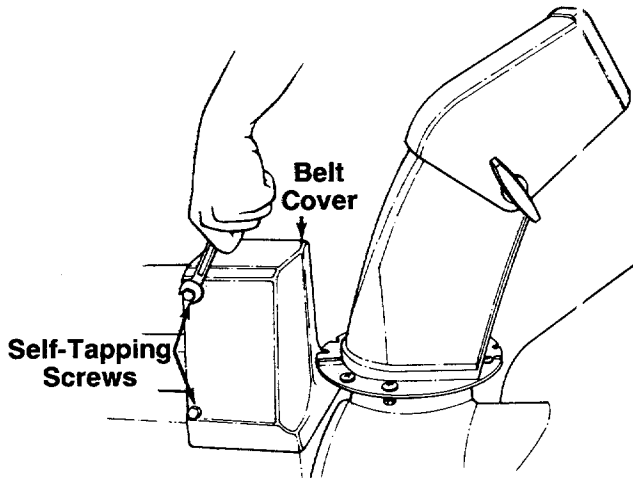

FIGURE 26.

2. Locate the brake linkage assembly (bracket with slot). See figure 27.

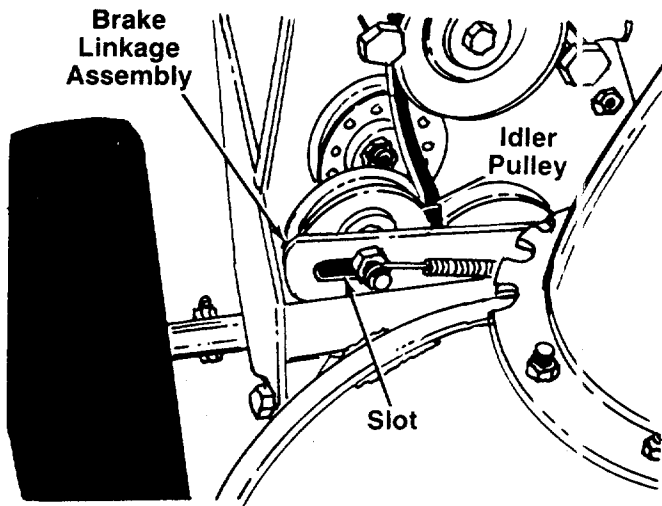

FIGURE 27.

3. Squeeze auger clutch lever all the way down against the handle as shown in figure 28, and check the position of the brake linkage. It should be against the idler pulley. See figure 29. If necessary, adjust the ferrule on end of auger cable until the slot on brake linkage is over against the idler pulley with the auger clutch lever all the way down against the handle.

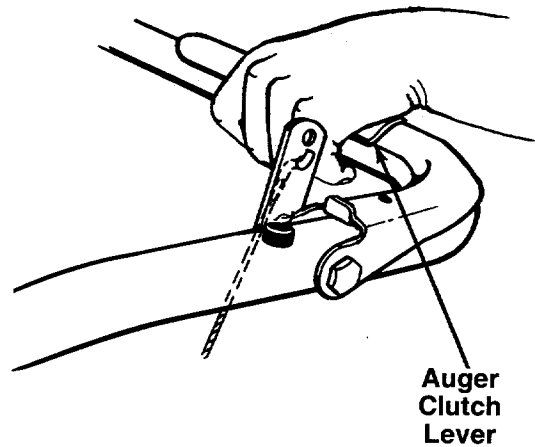

FIGURE 28.

4. Secure the ferrule to the auger bracket with flat washer and hairpin clip. See figure 29.
5. Replace the belt cover, using four self-tapping screws. Be careful not to overtighten the self-tapping screws to prevent stripping.

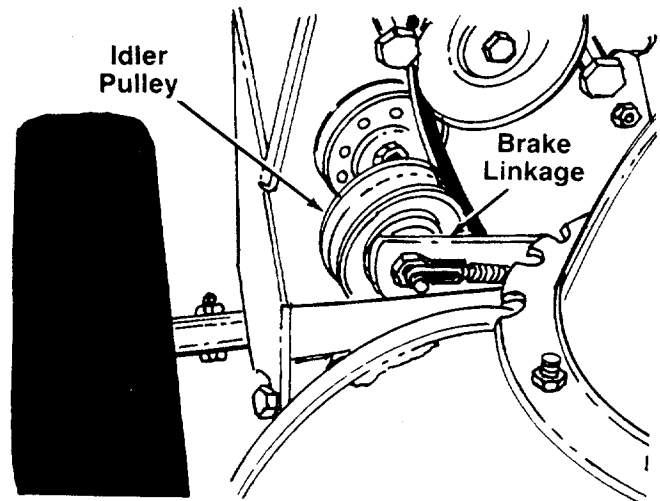

FIGURE 29.

BELT REPLACEMENT Auger Drive Belt

1. Disconnect the spark plug wire from the spark plug.
2. Disconnect chute crank assembly at the discharge chute by removing the cotter pin and flat washer.
3. Remove the plastic belt cover on the front of the engine by removing four self-tapping screws. Refer to figure 26. A 1/2" wrench is required.
4. Remove two engine pulley belt guards. See figure 30.
5. Roll auger drive belt off the engine pulley.

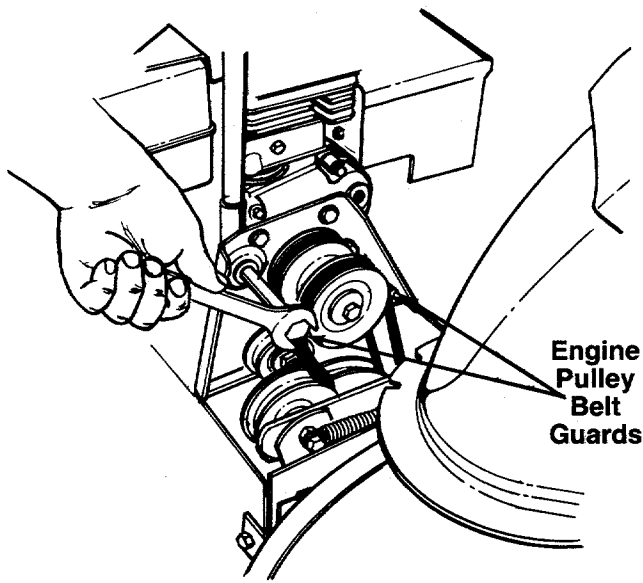

FIGURE 30.

6. Separate the snow thrower into two halves as follows.
 - a. Using a 9/16" wrench, remove the top bolts which attach the auger housing to the frame assembly. Loosen (do not remove) the bottom bolts. See figure 31.
 - b. Lift up on the auger drive belt to pull the auger housing off the frame assembly. The snow thrower will separate into two halves.
 - c. Tip the auger housing forward so it rests on the front of the housing.

NOTE

Be certain to check the condition of the drive belt when the two halves of the unit are separated. Replace if necessary.

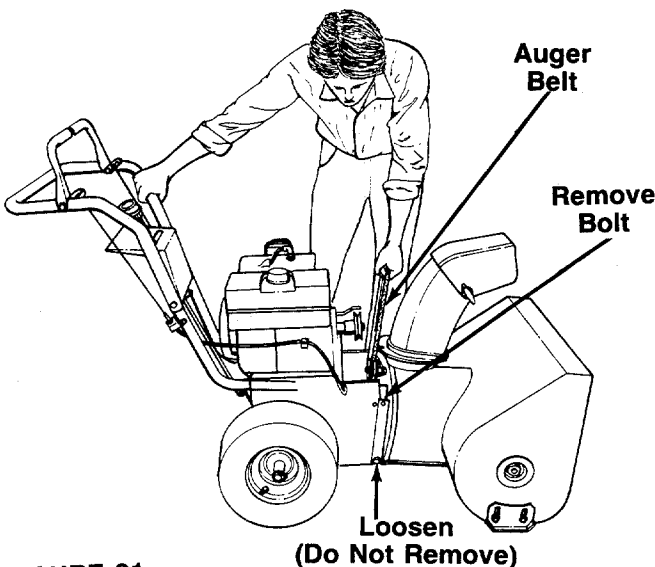

FIGURE 31.

7. Using a 15/16" wrench, remove the four shoulder bolts and cupped washers which act as belt keepers. See figure 32.
8. Roll belt off the auger pulley.
9. Reassemble new belt in reverse order.

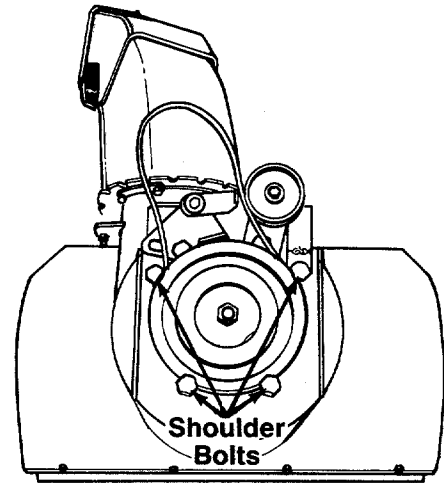

FIGURE 32.

Drive Belt

1. Follow steps 1 through 6 of the previous section.
2. Disconnect the extension spring at the engine plate. See figure 33.
3. Remove the drive belt from the engine pulley and bottom drive pulley. See figure 33.

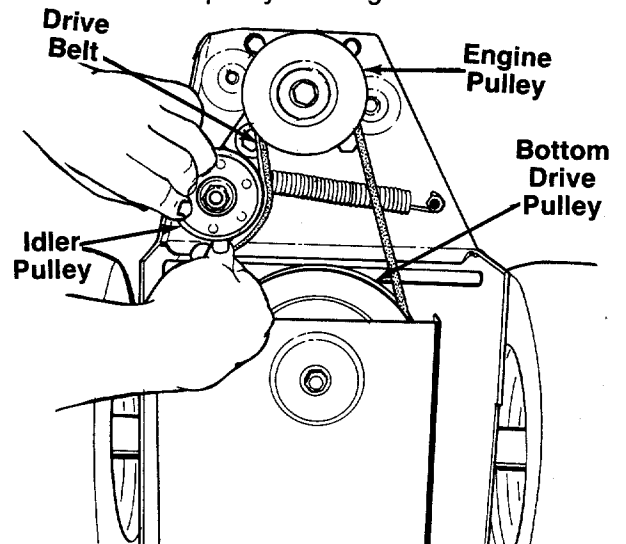

FIGURE 33.

4. Replace belt. Reassemble snow thrower, following instructions in reverse order.

NOTE

Be certain the auger arm assembly pin is in the slot of auger clutch bracket before inserting top bolts into auger housing and frame. See figure 34.

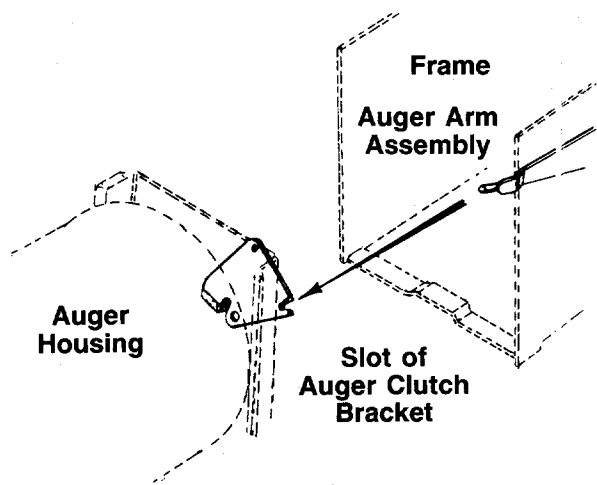

FIGURE 34.

CHANGING THE FRICTION WHEEL

1. Place the speed select lever into the second reverse position. (Friction wheel will move over to the extreme left side, inside the frame.)
2. Tip the snow thrower up and forward, so it rests on the auger housing. Block securely in this position.
3. Using a 3/8" wrench, remove the bottom frame cover by removing six self-tapping screws. See figure 35.

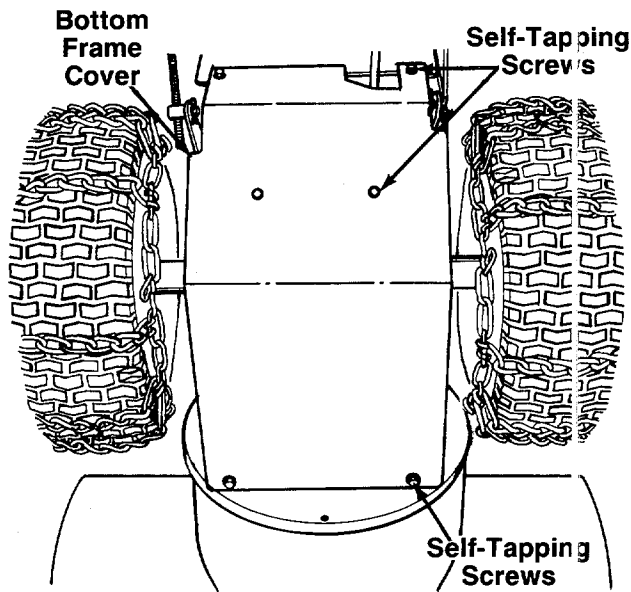

FIGURE 35.

4. Using a 1/2" wrench, remove the three hex bolts which hold the friction wheel to the friction wheel adapter. See figure 36.

NOTE

If may be necessary to tap the friction wheel with a hammer to knock it loose.

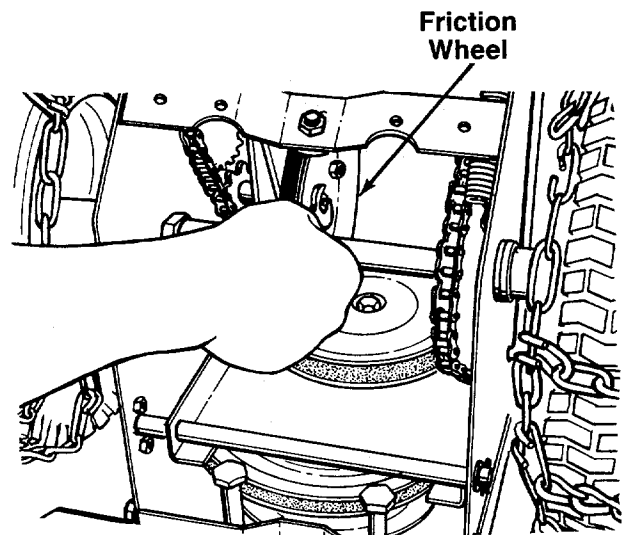

FIGURE 36.

5. Assemble the new friction wheel so the cupped side is opposite the friction wheel adapter.
6. Fasten the friction wheel to the friction wheel adapter with the three hex bolts. Tighten each nut in rotation until they are finger tight.
7. Spin the wheel to see that it is not cocked on the hub. Then, using a 1/2" wrench, tighten securely.
8. Replace the bottom frame cover.

AUGER SHEAR BOLT REPLACEMENT

The augers are secured to the auger shaft with two special shear bolts and hex lock nuts. If you hit a foreign object or ice jam, snow thrower is designed so the bolts will break (to protect the snow thrower). Refer to figure 25.

If the augers will not turn, check to see if the hex bolts have sheared. Two spare bolts and hex lock nuts have been provided with the snow thrower. Use only original equipment shear bolts and nuts, part numbers 710-0890 (shear bolt) and 712-0429 (hex lock nut).

SPARK PLUG

Clean spark plug and reset gap periodically. Clean area around spark plug base before removing to prevent dirt from entering engine. Replace spark plug if electrodes are pitted or burned, or if porcelain is cracked. Spark plug replacement is recommended at beginning of each season. Refer to Engine Repair Parts section of this manual for proper replacement plug. If reusing spark plug, clean by carefully scraping electrodes (do not sand blast or use wire brush). Be certain entire spark plug is clean. Check electrodes gap with a wire feeler gauge, and reset gap to 0.030 if necessary. See figure 37.

Install spark plug in engine, and tighten securely. If torque wrench is available, torque plug to between 18 and 23 foot pounds.

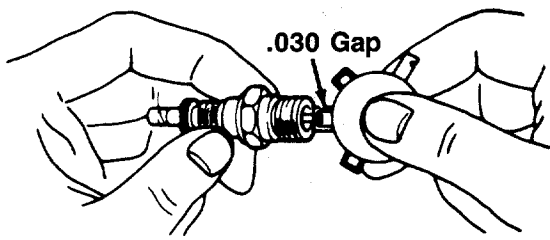

FIGURE 37.

CARBURETOR ADJUSTMENT



If any adjustments are made to the engine while the engine is running (e.g., carburetor), keep clear of all moving parts. Be careful of heated surfaces and muffler.

The carburetor has been pre-set at the factory and should not require adjustment. However, if the carburetor needs adjustment, proceed as follows. See figure 38.

1. Close high speed adjusting screw by hand. Do not overtighten. Then open it 1-1/4 to 1-1/2 turns.
2. Close idle adjusting screw by hand. Do not overtighten. Then open it 1-1/4 to 1-1/2 turns.
3. Start the engine, and allow it to warm up.
4. Set the throttle control to FAST. Adjust high speed adjusting screw in or out until the engine runs smoothly at full throttle. If the engine has a tendency to stall under load, open high speed adjusting screw slightly to obtain a richer fuel mixture.

5. Set the throttle control to SLOW. Adjust idle adjusting screw in or out until the engine runs smoothly at idle.

Allow the engine to run undisturbed for a few seconds between each new setting so that the engine can react to each setting.



Never tamper with the engine governor, which is set at the factory for proper engine speed. Overspeeding the engine above factory high speed setting is dangerous. If you think the engine governed high speed needs adjusting, contact your nearest SEARS Service Center, who has the proper equipment and experience to make any necessary adjustments.

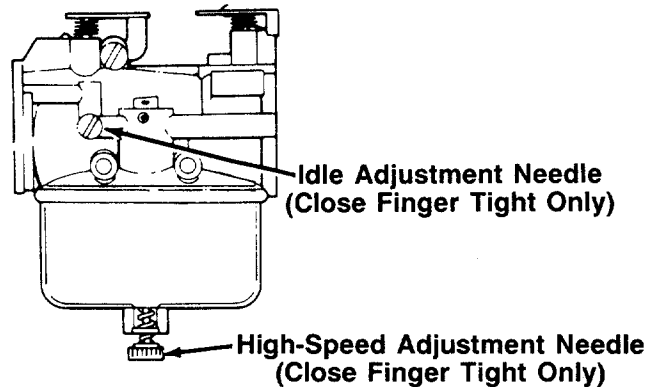

FIGURE 38.

TROUBLE SHOOTING GUIDE

TROUBLE	POSSIBLE CAUSE(S)	CORRECTIVE ACTION
Engine fails to start	<ol style="list-style-type: none"> 1. Fuel tank empty, or stale fuel. 2. Blocked fuel line. 3. Key not in switch or engine. 4. Spark plug wire disconnected. 5. Faulty spark plug. 	<ol style="list-style-type: none"> 1. Fill tank with clean, fresh gasoline. 2. Clean fuel line. 3. Insert key. 4. Connect wire to spark plug. 5. Clean, adjust gap or replace.
Engine runs erratic	<ol style="list-style-type: none"> 1. Unit running on CHOKE. 2. Blocked fuel line or stale fuel. 3. Water or dirt in fuel system. 4. Carburetor out of adjustment. 	<ol style="list-style-type: none"> 1. Turn choke knob to OFF position. 2. Clean fuel line; fill tank with clean fresh gasoline. 3. Remove carburetor bowl to drain fuel tank. Refill with fresh fuel. 4. Adjust carburetor (see Carburetor Adjustment in Adjustments/Repairs section of this manual).
Loss of power	<ol style="list-style-type: none"> 1. Spark plug wire loose. 2. Gas cap vent hole plugged. 	<ol style="list-style-type: none"> 1. Connect and tighten spark plug wire. 2. Remove ice and snow from cap. Be certain vent hole is clear.
Engine overheats	<ol style="list-style-type: none"> 1. Carburetor not adjusted properly. 2. Engine oil level low. 	<ol style="list-style-type: none"> 1. Adjust carburetor (see Carburetor Adjustment in Adjustments/Repairs section of this manual). 2. Fill crankcase with the proper oil.
Excessive vibration	Loose parts or damaged impeller.	Stop engine immediately and disconnect spark plug wire. Tighten all bolts and nuts. Make all necessary repairs. If vibration continues, have unit serviced by a SEARS Service Center.
Hard to shift, or will not shift	Speed select rod misadjusted	Readjust speed select rod (see Speed Select Lever Adjustment in Adjustments/Repairs section of this manual).
Unit fails to propel itself	<ol style="list-style-type: none"> 1. Unit in neutral. 2. Kwik pins not in proper position. 3. Incorrect adjustment of traction drive cable. 4. Drive belt loose or damaged. 	<ol style="list-style-type: none"> 1. Move speed select lever to one of the 5 forward speeds or reverse (readjust speed select lever if needed). 2. Place kwik pins in wheel hub. 3. Adjust traction drive cable. Refer to Cable Adjustment in Adjustments/Repairs section of this manual. 4. Replace drive belt. Refer to Belt Replacement in Adjustments/Repairs section of this manual.
Unit fails to discharge snow	<ol style="list-style-type: none"> 1. Shear bolt broken. 2. Discharge chute clogged. 3. Foreign object lodged in auger. 4. Incorrect adjustment of auger drive cable. 5. Auger drive belt loose or damaged. 	<ol style="list-style-type: none"> 1. Replace shear bolt. Refer to Auger Shear Bolt Replacement in Adjustments/Repairs section of this manual. 2. Stop engine immediately and disconnect spark plug wire. Clean discharge chute and inside of auger housing. 3. Stop engine immediately and disconnect spark plug wire. Remove object from auger. 4. Adjust auger drive cable. Refer to Cable Adjustment in Adjustments/Repairs section of this manual. 5. Replace auger drive belt. Refer to Belt Replacement in Adjustments/Repairs section of this manual.

NOTE: For repairs beyond the minor adjustments listed above, please contact your nearest SEARS Service Center.

NOTES

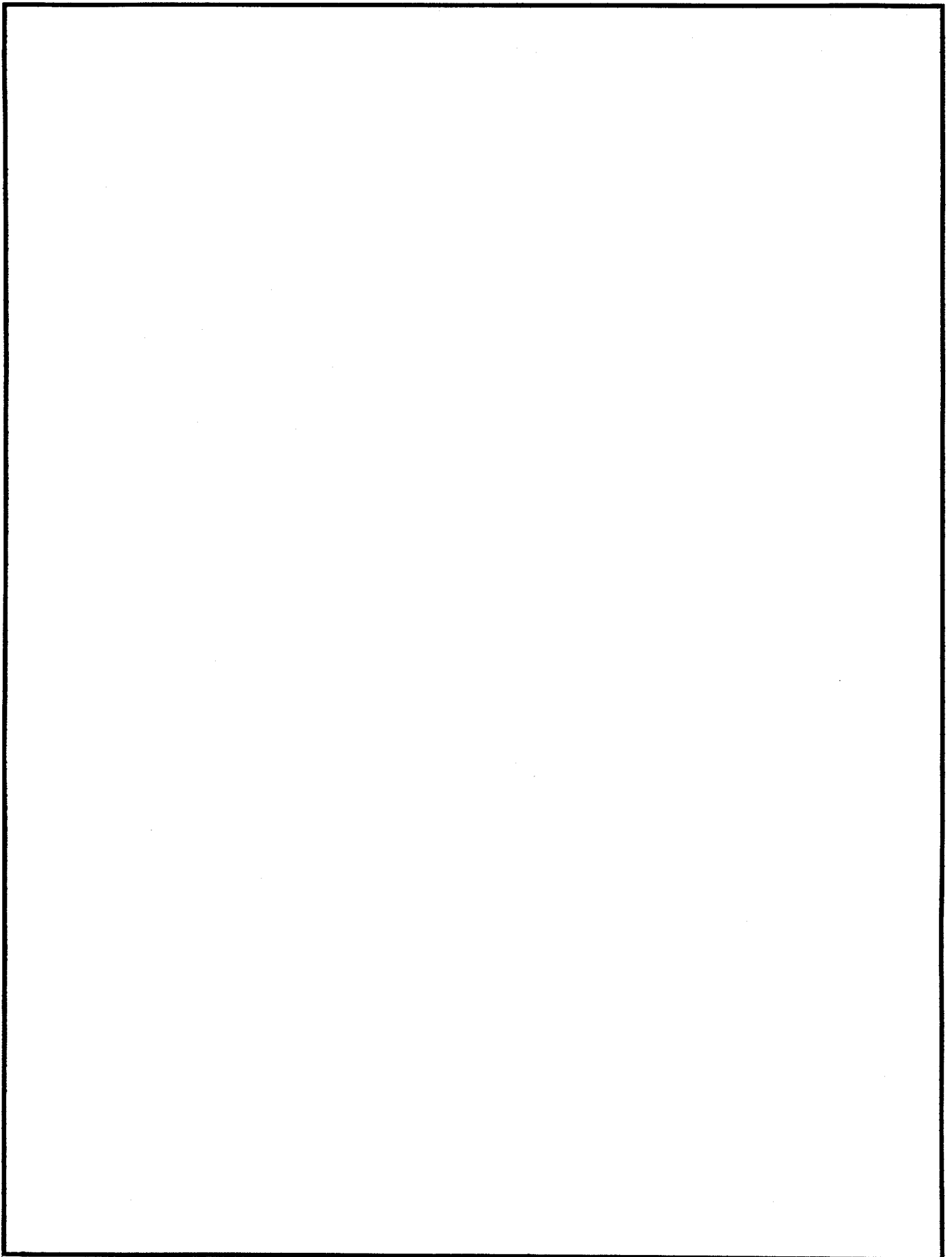

SEARS CRAFTSMAN 23" SNOW THROWER MODEL NO. 247.886510
Repair Parts—Handle Details

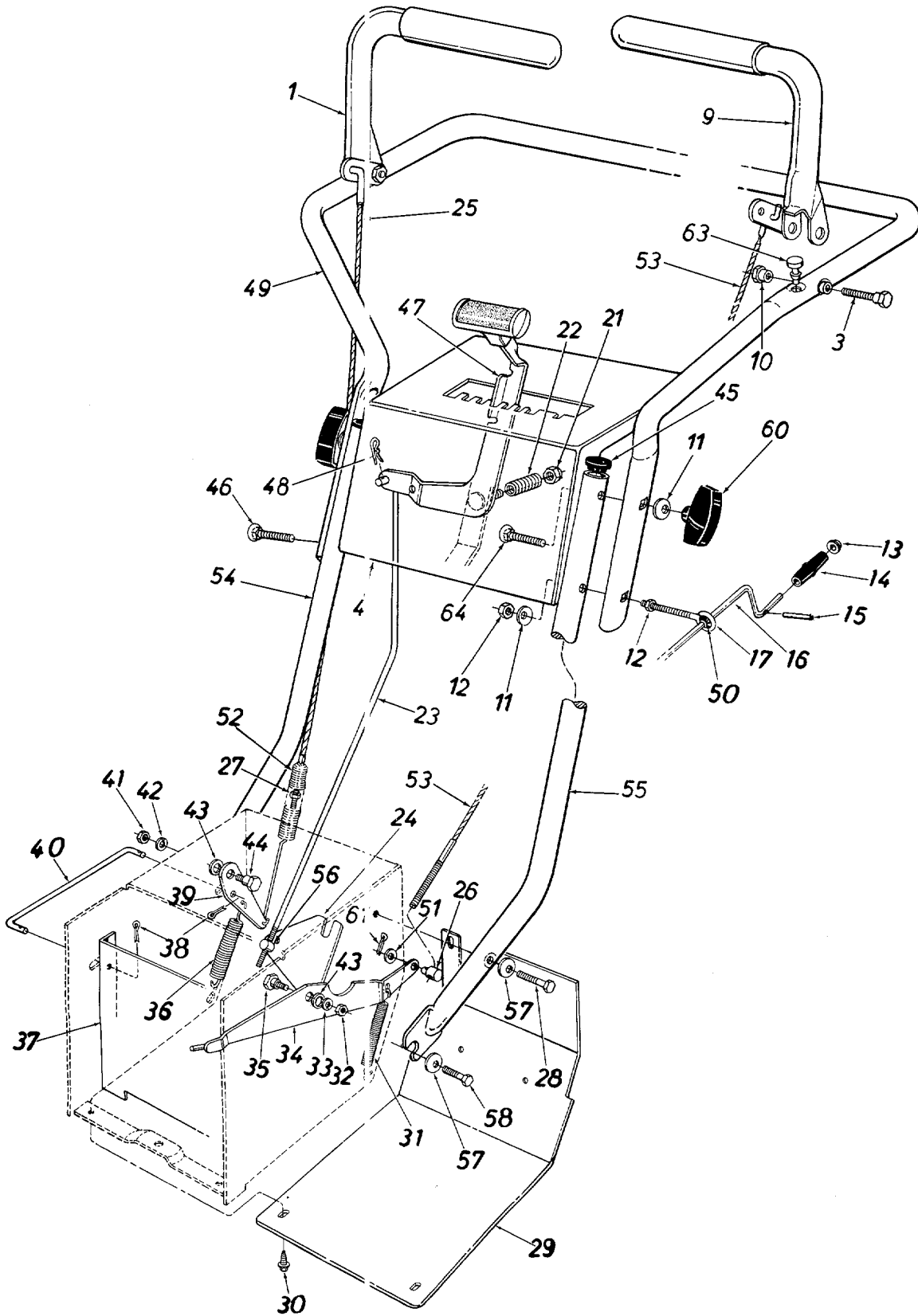

SEARS CRAFTSMAN 23" SNOW THROWER MODEL NO. 247.886510

Repair Parts

KEY NO.	PART NO.	DESCRIPTION	KEY NO.	PART NO.	DESCRIPTION
1	784-5440	Clutch Grip Ass'y.—R.H.	36	732-0121	Extension Spring .75" O.D.
3	738-0560	Shoulder Bolt .374 Dia. x 1.375" Lg.	37	05878	x 4.31" Lg. Drive Pulley Support Brkt. Ass'y.
4	784-5441	Handle Panel Ass'y.	38	714-0507	Cotter Pin 3/32" Dia. x .75" Lg.*
9	784-5439	Clutch Grip Ass'y.—L.H.	39	05501	Drive Clutch Bracket
10	738-0561	Shoulder Nut 1/4-20 Thd.	40	10080	Drive Clutch Rod
11	736-0242	Bell-Wash. .34" I.D. x .88" O.D.	41	712-0342	Hex Jam Nut 3/8-16 Thd.*
12	712-0267	Hex Nut 5/16-18 Thd.*	42	736-0169	L-Wash. 3/8" I.D.*
13	726-0100	Push Nut 3/8" Rod	43	736-0219	Bell-Wash. .40" I.D. x 1.13" O.D.
14	720-0201A	Knob 3/8" Rod	44	738-0281	Shld. Bolt .625" Dia. x .170
15	715-0138	Roll Pin .12 Dia. X .63" Lg.	45	731-0496	Plastic Plug
16	05980	Chute Crank Ass'y. 39" Lg.	46	710-0487	Carriage Bolt 5/16-18 x 2.0" Lg.
17	747-0416A	Eye Bolt 5/16-18 x 5.0" Lg.	47	705-5034	Shift Lever Ass'y.
21	712-0116	Hex Ins. L-Nut 3/8-24 Thd.	48	714-0104	Int. Cotter Pin 5/16" Dia.
22	732-0193	Compression Spring .50" O.D. x .88" Lg.	49	749-0783	Upper Handle Ass'y.
23	747-0581	Shifting Rod	50	741-0475	Plastic Bushing
24	05898	Shifting Linkage Bracket	51	736-0264	Fl-Wash. .344" I.D. x .62" O.D.
25	746-0367	Lockout Cable 30.5" Lg.	52	732-0411	Extension Spring .78" O.D. x 7.5" Lg.
26	711-0736	Adjustment Ferrule 1/4-20	53	746-0435	Auger Clutch Cable 36" Lg.
27	712-0324	Hex Ins. L-Nut 1/4-20 Thd.	54	749-0788	Lower Handle—R.H.
28	710-0427	Hex Bolt 3/8-16 x 2.00" Lg.*	55	749-0789	Lower Handle—L.H.
29	05899	Frame Cover	56	711-0677	Adjustment Ferrule
30	710-0599	Hex Wash. Self-Tap Scr. 1/4-20 x .50" Lg.	57	736-0105	Bell-Wash. .40" I.D. x .88" O.D.
31	732-0320	Extension Spring .38" O.D. x 3.25" Lg.	58	710-0623	Hex Wash. Self-Tap Scr. 3/8-16 x .75" Lg.
32	712-0342	Hex Jam Nut 3/8-16 Thd.*	60	09966	Hand Knob
33	736-0169	L-Wash. 3/8" I.D.*	61	714-0507	Cotter Pin 3/32" Dia.
34	784-5050	Auger Clutch Bracket Ass'y.	63	735-0199	Rubber Bumper
35	738-0281	Shld. Bolt .625" Dia. x .170	64	710-0572	Carriage Bolt 5/16-18 x 2.5" Lg.

*Common Hardware—May be purchased locally.

SEARS CRAFTSMAN 23" SNOW THROWER MODEL NO. 247.886510
Repair Parts—Drive Mechanism Details

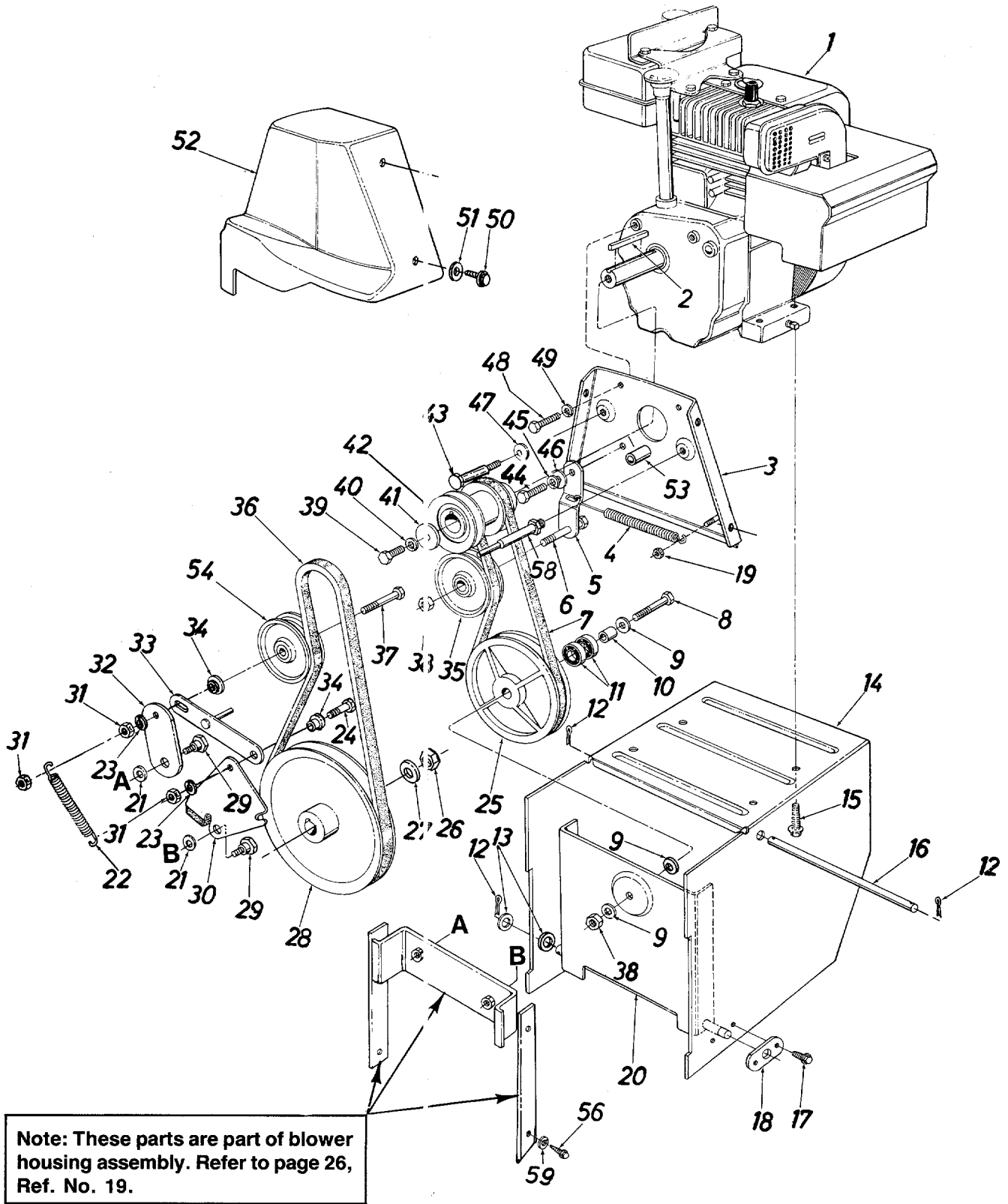

Note: These parts are part of blower housing assembly. Refer to page 26, Ref. No. 19.

SEARS CRAFTSMAN 23" SNOW THROWER MODEL NO. 247.886510

Repair Parts—Drive Mechanism Details

KEY NO.	PART NO.	DESCRIPTION	KEY NO.	PART NO.	DESCRIPTION
1	—	Engine	28	756-0344	1/2" V-Pulley .625" I.D. x 7.50" O.D.
2	714-0133	Sq. Key 3/16" x 1.50" Lg.	29	738-0281	Shld. Bolt .625" Dia. x .170" Lg. (3/8-16)
3	05872	Engine Plate Ass'y.	30	784-5061	Brake Bracket Ass'y.
4	732-0429 A	Extension Spring .50" O.D. x 3.97" Lg.	31	712-0342	Hex Ins. L-Nut 3/8-16 Thd.
5	05896	Drive Clutch Idler Brkt.	32	05895	Auger Clutch Idler Brkt.
6	710-0191	Hex Bolt 3/8-24 x 1.25" Lg.*	33	784-5245	Brake Linkage Ass'y.
7	754-0256	"V"-Belt	34	738-0347	Shld. Spacer .625" I.D.
8	710-0459	Hex Bolt 3/8-24 x 1.50" Lg.*	35	756-0137	FI-Idler Pulley 2.25" O.D.
9	736-0105	Bell-Wash. .40" I.D. x .88" O.D. x .06	36	754-0257	"V"-Belt
10	711-0396	Spacer .38" I.D. x .62" O.D. x .75" Lg.	37	710-0427	Hex Bolt 3/8-16 x 2" Lg.*
11	741-0155	Ball Brg. .62" I.D. x 1.38" O.D. x .44	38	712-0116	Hex Ins. Jam L-Nut 3/8-24 Thd.
12	714-0507	Cotter Pin 3/32" Dia. x .75" Lg.*	39	710-0459	Hex Bolt 3/8-24 x 1.50" Lg.
13	736-0272	FI-Wash. .53" I.D. x 1.00" O.D. x .125	40	736-0169	L-Wash. 3/8" I.D.*
14	784-5197	Frame Ass'y.	41	736-0247	Bell-Wash. .40" I.D. x 1.25" O.D.
15	710-0502	Hex Wash. Hd. Self-Tap Scr. 3/8-16 x 1.25" Lg.	42	756-0421	Double Groove Engine Pulley
16	738-0497	Shaft .50" Dia. x 9.50" Lg.	43	738-0215	Shld. Scr. .498" x 3.0" Lg.
17	710-0599	Hex Wash. Hd. Self-Tap Scr. 1/4-20 x .50" Lg.	44	710-0117	Hex Bolt 5/16-24 x 1.00" Lg.*
18	05897	Axle Bracket	45	736-0119	L-Wash. 5/16" I.D.*
19	712-0107	Hex L-Nut 1/4-20 Thd.	46	748-0234	Shld. Spacer .27" Lg.
20	05878	Drive Pulley Support Brkt. Ass'y.	47	736-0105	Bell-Wash. .40" I.D. x .88" x .06
21	736-0219	Bell-Wash. .40" I.D. x 1.13" O.D.	48	710-0237	Hex Bolt 5/16-24 x .62" Lg.*
22	732-0550	Extension Spring .56" O.D. x 4" Lg.	49	736-0119	L-Wash. 5/16" I.D.*
23	736-0169	L-Wash. 3/8" I.D.*	50	710-0599	Hex Wash. Hd. Self-Tap Scr. 1/4-20 x .50" Lg.
24	710-0723	Hex Scr. 3/8-16 x 1.25" Lg.	51	736-0173	FI-Wash. .28" I.D. x .75" O.D. x .06
25	05921	6.00" O.D. Drive Pulley Ass'y. (Incl. Ref. #11)	52	731-0642	Belt Cover
26	712-0923	Hex Jam Cent. L-Nut 5/8-18 Thd.	53	750-0456	Spacer
27	736-0116	FI-Wash. .64" I.D. x .94" O.D. x .06	54	756-0225	FI-Idler Pulley 2.75" O.D.
			55	710-0623	Hex Wash. Hd. Self-Tap Scr. 3/8-16 x .75" Lg.
			57	725-0954	Ignition Key (Not Shown)
			58	711-0769	Stud 3/8-16 x 3.37" Lg.
			59	736-0217	L-Wash. 3/8" I.D.—H.D.

*Common Hardware—May be purchased locally.

SEARS CRAFTSMAN 23" SNOW THROWER MODEL NO. 247.886510
Repair Parts—Auger/Housing Details

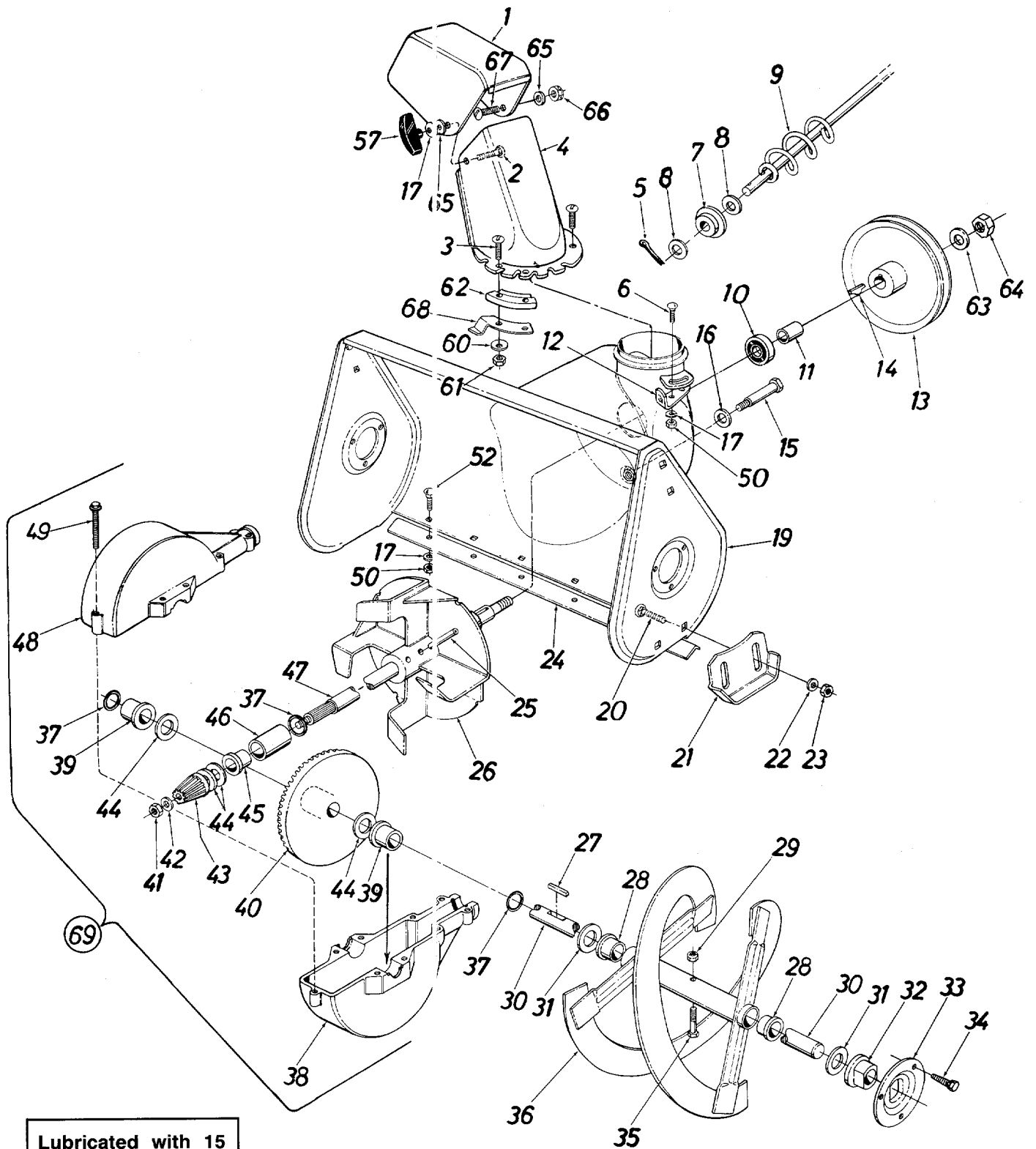

Lubricated with 15 oz. of Shell Alvania Grease EPR00, Part No. 737-0168.

SEARS CRAFTSMAN 23" SNOW THROWER MODEL NO. 247.886510

Repair Parts

KEY NO.	PART NO.	DESCRIPTION	KEY NO.	PART NO.	DESCRIPTION
1	731-0848	Upper Chute	34	710-0726	Hex Wash. Hd. Self-Tap Scr. 5/16-24 x .62" Lg.
2	710-0276	Carriage Bolt 5/16-18 x 1.0" *	35	710-0890	Hex Bolt 5/16-18 x 1.50" Lg.
3	710-0255	Truss Mach. Scr. 1/4-20 x .75" *	36	05923	Spiral Ass'y.—L.H.
4	731-0844	Lower Chute	36	05924	Spiral Ass'y.—R.H. (Not Shown)
5	714-0507	Cotter Pin	37	721-0176	"O"-Ring—3/4" I.D.
6	710-0451	Carriage Bolt 5/16-18 x .75" *	38	717-0456	Bevel Gear Housing—Lower Half
7	741-0475	Bushing	39	741-0293	Plastic Flange Brg. .755" I.D.
8	736-0140	FI-Wash. .385 I.D. x .62" O.D.	40	717-0457	Bevel Gear
9	05980	Chute Crank Ass'y.	41	712-0237	Hex Cent. L-Nut 5/16-24 Thd.
10	741-0155	Ball Brg. .62" I.D. x 1.38" O.D.	42	736-0264	FI-Wash. .34" I.D. x .62" O.D. x .06
11	750-0118	Spacer .63" I.D. x .88" O.D. x .900" Lg.	43	748-0237	Pinion Gear
12	784-5123	Chute Crank Brkt.	44	736-0287	FI-Wash. .75" I.D. x 1.25" O.D. x .06
13	756-0344	1/2" "V"-Pulley .625" I.D. x 7.50" O.D.	45	748-0171	Flange Brg. .755" I.D.
14	714-0388	#61 Hi-Pro Key 3/16" x 5/8" Dia.	46	748-0106	Sleeve Brg. .755" I.D.
15	738-0154	Shld. Bolt .50" Dia. x 2.11"	47	738-0649	Blower Axle
16	736-0105	Bell-Wash. .40" I.D. x .88" O.D. x .06	48	717-0455	Bevel Gear Housing—Upper Half
17	736-0242	Bell-Wash. .34" I.D. x .88" O.D.	49	710-0588	Hex Wash. Hd. Self-Tap Scr. 1/4-20 x 1.00" Lg.
19	784-5443	Blower Housing Ass'y.	50	712-0267	Hex Nut 5/16-18 Thd.*
20	710-0790	Carriage Bolt 3/8-16 x .62" *	52	710-0260	Carriage Bolt 5/16-18 x .62" Lg.*
21	05002	Slide Shoe	57	09966	Knob
22	736-0105	Bell-Wash. 3/8" I.D.	60	736-0142	FI-Wash. 1/4" I.D.
23	712-0342	Hex Jam Nut 3/8-16 Thd.	61	712-0107	Hex L-Nut 1/4-20 Thd.*
24	05847	Shave Plate	62	731-0851	Chute Flange Keeper
25	715-0114	Spring Pin Spiral 1/4" Dia. x 1.50" Lg.	63	736-0116	FI-Wash. .64" I.D. x .94" O.D. x .06
26	05865	11" Dia. Blower Fan Ass'y.	64	712-0923	Hex Jam Nut 5/8-18 Thd.
27	714-0133	Sq. Key 3/16" x 1.5" Lg.	65	736-0231	FI-Wash. .344 I.D. x 1.125 O.D.
28	741-0493	Flange Brg. .75" I.D. x .88" O.D.	66	712-0158	Hex L-Nut 5/16-18 Thd.
29	712-0429	Hex Ins. L-Nut 5/16-18	67	710-0323	Truss Mach. Scr. 5/16-18 x .75" Lg.*
30	738-0488A	Spiral Axle	68	784-0273	Chute Stop
31	736-0188	FI-Wash. .75" I.D. x 1.50" O.D. x .06	69	717-0867A	Gear Box Complete
32	741-0300	Flange Brg. w/Flats .755" I.D.			
33	05845	Bearing Housing			

*Common Hardware—May be purchased locally.

SEARS CRAFTSMAN 23" SNOW THROWER MODEL NO. 274.886510

Repair Parts

KEY NO.	PART NO.	DESCRIPTION	KEY NO.	PART NO.	DESCRIPTION
1	784-5197	Frame Ass'y.	32	736-0264	Fl-Wash. .34" I.D. x .64" O.D. x .06
2	750-0499	Spacer .50" I.D. x .75" O.D. x .78" Lg.	33	714-0507	Cotter Pin 3/32" Dia. x .75" Lg.*
4	714-0129	#4 Hi-Pro Key 3/32 x 5/8" Dia.	34	716-0145	Snap Ring .562" Dia. Shaft
5	05080	Friction Wheel Ass'y.	35	713-0280	Sprocket 7 Teeth x .50" Pitch
6	738-0496	Hex Shaft	36	738-0497	Shaft .50" Dia. x 9.50" Lg.
7	05883	Friction Wheel Mounting Plate Ass'y.	37	713-0323	32 Teeth Wheel Axle Ass'y.
8	716-0102	Snap Ring 1.00" Dia. Shaft	38	710-0600	Hex Wash. Hd. Self-Tap Scr. 5/16-24 x .50" Lg.
9	736-0163	Fl-Wash. 1.00" x 1.63" O.D. x .03	39	713-0287	#420 Chain 1/2" Pitch x 39 Links
10	05880	Sliding Bracket Ass'y.	40	713-0154	Master Link for #420 Chain
12	713-0285	#41 Chain 1/2" Pitch x 35 Links	41	748-0204	8 Teeth Center Sprocket
13	713-0723	Master Link for #41 Chain	42	736-0119	L-Wash. 5/16" I.D.*
14	713-0281	32 Teeth Sprocket Ass'y.	43	741-0476	Bearing
15	741-0225	Hex Flange Brg. .630" I.D.	44	748-0184	Bronze Bearing
16	736-0290	Fl-Wash. .62" I.D. x 1.00" O.D. x .06	45	736-0188	Fl-Wash. .76" I.D. x 1.49 O.D.
17	710-0538	Hex Lock Bolt 5/16-18 x .62" Lg.	46	734-1253	Wheel Assembly
18	714-0507	Cotter Pin 3/32" Dia. x .75" Lg.*		734-1147	Rim Only
20	741-0245	Hex Flange Brg. .751" I.D.		734-0298	Tire Only
21	736-0231	Fl-Wash. .34" I.D. x 1.12" O.D. x .125	47	734-0255	Air Valve
25	712-0342	Hex Jam Nut 3/8-16 Thd.	48	714-0143	Klick Pin
26	736-0169	L-Wash. 3/8" I.D.*	49	716-0101	Snap Ring .75 Dia.
27	05898	Shifting Linkage Bracket	50	712-0200	Hex Ins. L-Nut 1/2-20 Thd.
29	738-0281	Shld. Bolt .625" Dia. x .170" Lg.	51	736-0257	Fl-Wash. .53 I.D. x 1.25 O.D. x .10
30	711-0677	Adjustment Ferrule	52	736-0253	Bell-Wash. .50 I.D. x 1.0 O.D. x .075
31	747-0356	Shifting Rod 5/16" Dia. x 32.50" Lg.	53	741-0401	Sleeve Brg.
			54	723-0389	Tire Chains

*Common Hardware—May be purchased locally.

SEARS CRAFTSMAN 5 H.P. ENGINE MODEL NO. 143.794082

Repair Parts

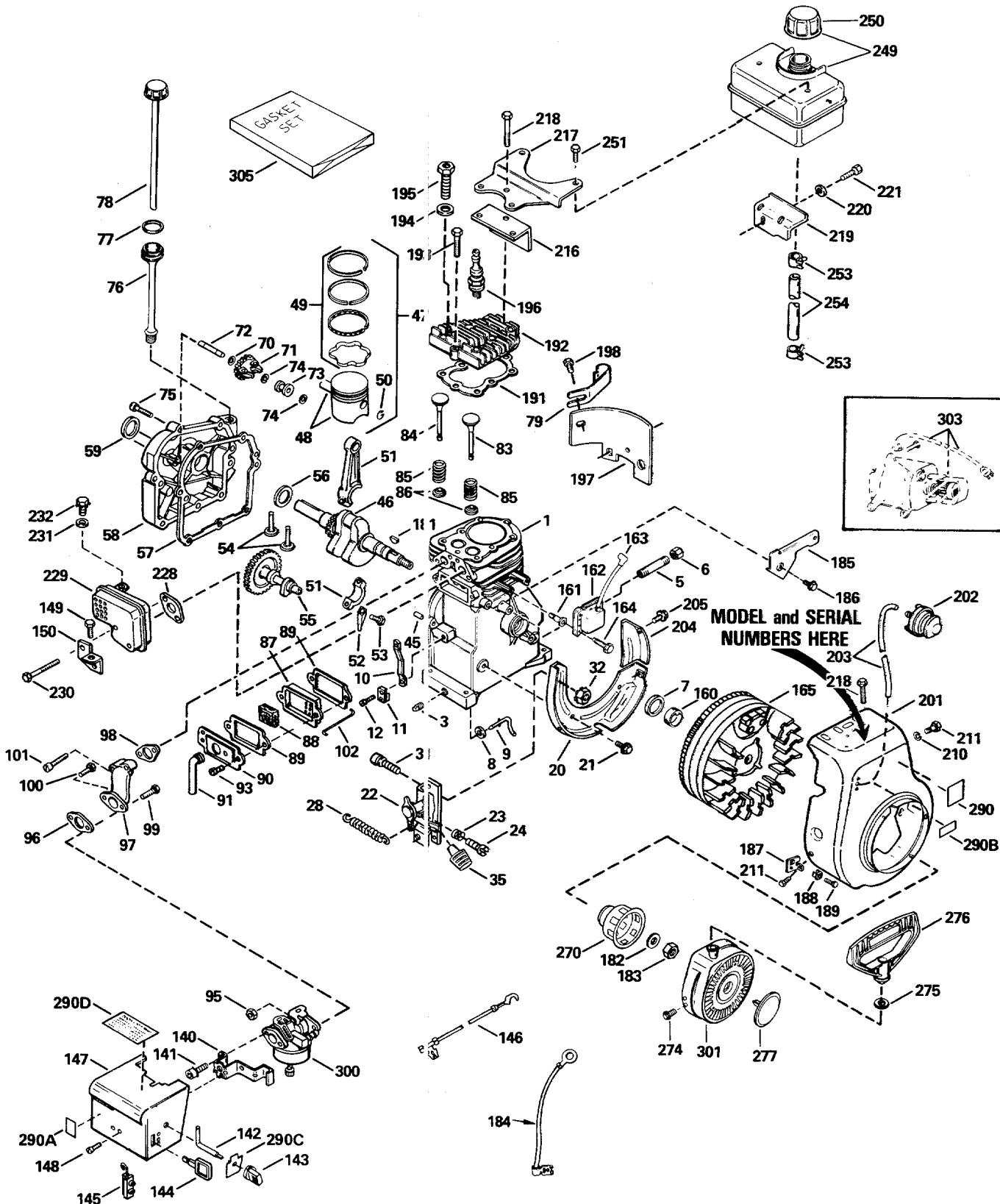

SEARS CRAFTSMAN 5 H.P. ENGINE MODEL NO. 143.794082

Repair Parts

KEY NO.	PART NO.	DESCRIPTION	KEY NO.	PART NO.	DESCRIPTION
1	33674B	Cylinder Ass'y. (Incl. Nos. 3, 7, & 45)	73	30588A	Spool, Governor
3	27642	Plug, Pipe, 1/4-18	74	29193	Ring, Retaining
5	30968	Nipple, Pipe	75	650488	Screw, Hex Hd. Sems, 1/4-20 x 1-1/4
6	30969	Cap, Oil Drain	76	35554	Tube Ass'y., Oil Fill
7	32600	Seal, Oil	77	35499	"O"-Ring
8	28277	Washer, Flat	78	35556	Dipstick
9	31334	Rod, Governor	79	35539	Clip, Oil Fill
10	31510	Lever, Governor	83	29313C	Valve, Exhaust (Std.) (Incl. No. 86)
11	31335	Clamp, Governor Lever	83	29315C	Valve, Exhaust (1/32" Oversize) (Incl. No. 86)
12	650548	Screw, Hex Washer Hd., 8-32 x 5/16	84	32644A	Valve, Intake (Std.) (Incl. No. 86)
20	†33342	Baffle, Blower Housing	84	32645A	Valve, Intake (1/32" Oversize) (Incl. No. 86)
21	650561	Screw, Hex Washer Hd. Durlok, 1/4-20 x 5/8	85	31672	Spring, Valve
22	33858A	Control Ass'y. Bracket (Incl. Nos. 23 thru 25, 31 & 32)	86	31673	Cap, Valve Spring
23	31342	Spring, Compression	87	27666	Body, Valve Cover
24	650549	Screw, Fil. Hd., 5-40 x 7/16	88	31410	Element, Valve Body
28	31426	Spring, Extension	89	*27234A	Gasket, Valve Cover
31	†650139	Screw, Fil. Hd. Sems, 8-32 x 1/2	90	34146	Cover, Breather
32	†30322	Nut, Lock, 8-32	91	35350	Tube, Breather
35	35440	Knob, Speed Control	93	650128	Screw, Hex Hd. Sems, 10-24 x 1/2
45	26727	Pin, Dowel	95	29752	Nut & Lock Washer Ass'y., 1/4-28
46	34740	Crankshaft Ass'y.	96	*26756	Gasket, Carburetor
47	34535	Piston, Pin & Ring Ass'y. (Std.) (Incl. Nos. 48, 49 & 50)	97	33691	Pipe, Intake
47	34536	Piston, Pin & Ring Ass'y. (.010 Oversize) (Incl. Nos. 48, 49 & 50)	98	*33673A	Gasket, Intake
47	34537	Piston, Pin & Ring Ass'y. (.020 Oversize) (Incl. Nos. 48, 49 & 50)	99	6201	Screw, Hex Hd., 1/4-28 x 7/8
48	33562B	Piston & Pin Ass'y. (Std.) (Incl. No. 50)	100	650870	Screw, Hex Hd., 1/4-28 x 1-11/16
48	33563B	Piston & Pin Ass'y. (.010 Oversize) (Incl. No. 50)	101	650664	Screw, Fil. Hd. Sems, 1/4-20 x 1-19/32
48	33564B	Piston & Pin Ass'y. (.020 Oversize) (Incl. No. 50)	102	32698	Link, Governor to Throttle
49	33567	Ring Set, Piston (Std.)	140	34583	Bracket, Choke
49	33568	Ring Set, Piston (.010 Oversize)	141	28820	Screw, Fil. Hd. Sems, 10-32 x 1/2
49	33569	Ring Set, Piston (.020 Oversize)	142	34582	Rod, Choke
50	20381	Ring, Piston Pin Retaining	143	35438	Knob, Choke Control
51	32875	Rod Ass'y., Connecting (Incl. Nos. 52 & 53)	144	725-1377	Key, Ignition
52	32654	Dipper, Oil	145	610973	Terminal Ass'y.
53	32610A	Bolt, Connecting Rod	146	35285	Wire, Ground
54	27241	Lifter, Valve	147	35072	Cover, Carburetor
55	33158	Camshaft (Compression Release)	148	650257	Screw, Pan Hd. Sems, 8-32 x 5/16
56	32323	Washer, Thrust	149	650735	Screw, Hex Hd. Sems, Taptite, 10-24 x 3/8
57	*27677A	Gasket, Cylinder Cover	150	33333	Bracket, Carburetor Cover
58	34674A	Cover, Cylinder (Incl. Nos. 59 & 72)	160	34080	Spacer, Flywheel Key
59	27897	Seal, Oil	161	650872	Stud, Solid State Mounting
70	35479	Washer, Flat	162	34443A	Solid State Ass'y.
71	30591	Gear, Governor (Incl. No. 70)	163	610118	Cover, Spark Plug
72	30574	Shaft, Mechanical Governor	164	650814	Screw, Torx Hex Washer Hd. Sems, 10-24 x 1
			165	611081	Flywheel (w/Ring Gear)
			181	610961	Key, Flywheel
			182	650815	Washer, Belleville

SEARS CRAFTSMAN 5 H.P. ENGINE MODEL NO. 143.794082

Repair Parts

KEY NO.	PART NO.	DESCRIPTION	KEY NO.	PART NO.	DESCRIPTION
183	650863	Nut, Flywheel	220	650675	Washer, Flat
184	35234	Wire, Ground	221	650805	Screw, Hex Hd., w/Belleville Washer, 1/4-20 x 11/16
185	34212	Bracket, Hold Down	228	*33670	Gasket, Exhaust
186	30200	Screw, Hex Washer Hd. Self-Tap Sems, 10-24 x 9/16	229	33697A	Muffler
187	34126	Bracket, Grommet Mounting	230	650327	Screw, Fil. Hd. Sems, 1/4-20 x 2-1/2
188	28545	Grommet, Plastic	231	8345	Washer, Flat
189	650760	Screw, Pan Hd. Taptite, 8-32 x 3/8	232	30063	Screw, Hex Washer Hd. Sems, 1/4-20 x 1/2
191	*33554A	Gasket, Cylinder Head	249	35584	Tank Ass'y., Fuel (Incl. Nos. 250 & 253)
192	33016A	Head, Cylinder (Incl. No. 218)	250	35355	Cap, Fuel Tank
193	6021A	Screw, Hex Flange Hd., 5/16-18 x 1-1/2	251	650665	Screw, Hex Washer Hd. Self-Tap Sems, 1/4-15 x 7/8
194	650691	Washer, Flat	253	26460	Clamp, Fuel Line
195	650818	Screw, Special Hex Hd., 5/16-18 x 1-1/2	254	30705	Line, Fuel
196	33636	Plug, Spark (Champion J-3C or Equivalent)	270	34694	Cup, Starter
197	29745	Extension, Blower Housing	274	650884	Screw, Hex Washer Hd. 8-32 x 1/2
198	650128	Screw, Hex Hd. Sems, 10-24 x 1/2	275	650168	Washer, Flat
201	35656	Housing, Blower	276	590574	Handle, Starter
202	570682	Primer Ass'y.	277	35392	Plug, Starter
203	32180C	Line, Primer	290	35312	Decal, Instruction
204	33341	Extension, Baffle	290A	34346	Decal, Instruction
205	650701	Screw, Hex Washer Hd. Shakeproof Self-Drilling, 8-18 x 7/16	290B	34144	Decal, Primer
210	650168	Washer, Flat	290C	35282	Decal, Choke
211	29212	Screw, Hex Hd. Sems, 1/4-28 x 7/16	290D	34414	Decal, Warning
216	33344	Baffle, Heat	300	632107	Carburetor (Incl. No. 96)
217	28371B	Plate, Fuel Tank	301	590646	Starter, Rewind
218	650694A	Screw, Hex Flange Hd., 5/16-18 x 2	303		Electric Starter Kit 143.88933 (Optional) Sold as an Accessory
219	34182	Bracket, Fuel Tank Mounting	305	33683B	Gasket Set (Incl. Items Marked *)

*Indicates Parts Included in Gasket Set, Ref. No. 305.

RPM Settings:
Low Speed: 1700, High Speed: 3450.

†In original production the speed control assembly is riveted to the blower housing baffle. Replacement speed control assembly includes screws and nuts for mounting. Replacement baffle has threaded holes.

SEARS CRAFTSMAN 5 H.P. ENGINE MODEL NO. 143.794082

Repair Parts

PARTS LIST FOR CARBURETOR

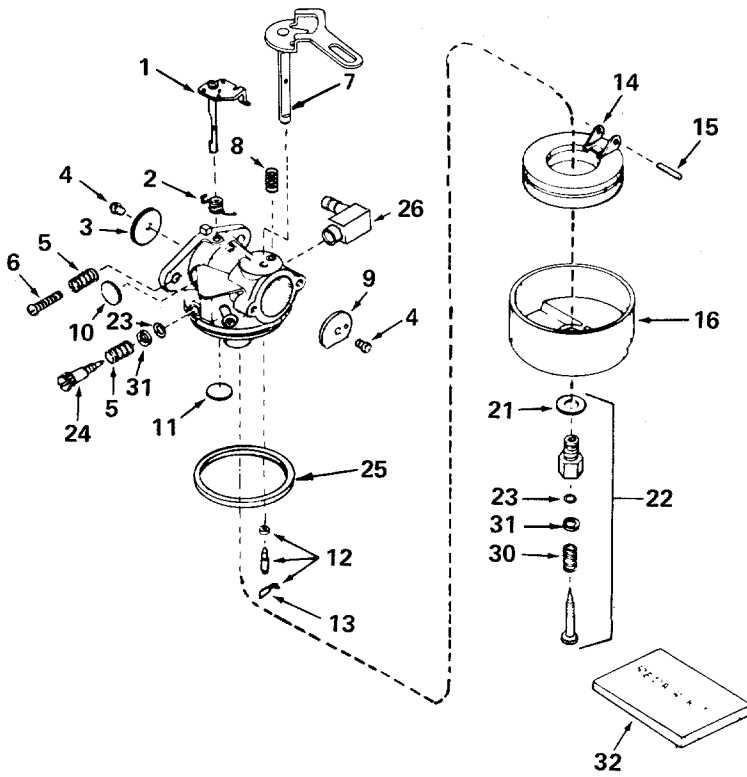

KEY NO.	PART NO.	DESCRIPTION
1	631615	Shaft & Lever Ass'y, Throttle
2	631767	Spring, Throttle Return
3	631036	Shutter, Throttle
4	650506	Screw, 4-40 x 3/16
5	630766	Spring, Idle Regulating Screw
6	650417	Screw, Idle Regulating
7	632108	Shaft & Lever Ass'y., Choke
8	630735	Spring, Choke Stop
9	631815	Shutter, Choke
10	*630748	Plug, Welch
11	*631027	Plug, Welch
12	*631021	Inlet Needle, Seat & Clip Ass'y. (Incl. No. 13)
13	631022	Clip, Inlet Needle
14	632019	Float, Carburetor
15	*631024	Shaft, Float
16	631867	Bowl, Float
21	27110	Gasket, Bowl-to-Body
22	*31839	Adjusting Screw Ass'y., Main (Incl. Nos. 21, 23, 30 & 31)
23	*630740	"O" Ring, Adjustment Screw
24	*631078	Screw, Idle Adjusting
25	*631028	Gasket, Bowl-to-Body
26	631807	Fitting, Fuel Inlet
30	630738	Spring, Main Adjustment Screw
31	630739	Washer, Flat
32	31840	Repair Kit (Incl. Items Marked *)
—	632107	Carburetor

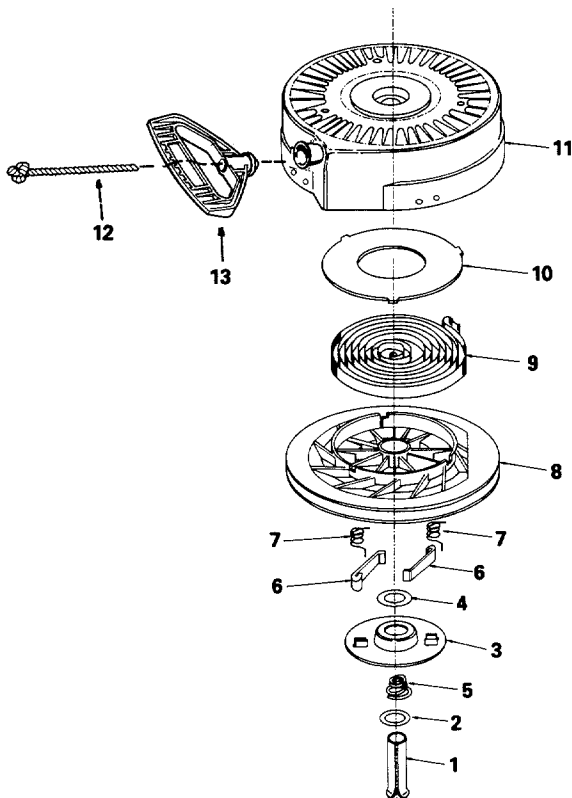

PARTS LIST FOR REWIND STARTER

KEY NO.	PART NO.	DESCRIPTION
1	590599A	Pin, Spring (Incl. No. 4)
2	590600	Washer
3	590615	Retainer
4	590601	Washer
5	590598	Spring, Brake
6	590616	Dog, Starter
7	590617	Spring, Dog
8	590645	Pulley
9	590619	Spring, Rewind
10	590620	Cover, Spring
11	590647	Housing Ass'y., Starter
12	590451A	Rope, Starter (Length 69" & 5/32" Dia.)
13	590574	Handle, Mitten Grip (Not Included With Starter)
—	590646	Rewind Starter Comp.

SEARS CRAFTSMAN OPTIONAL 120 VOLT ELECTRIC STARTER KIT NO. 143.88933

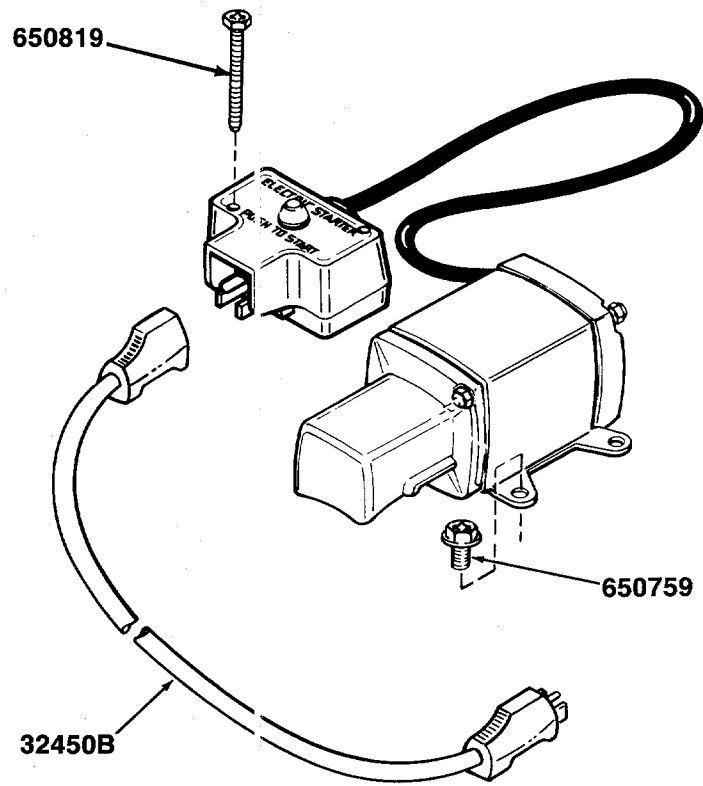

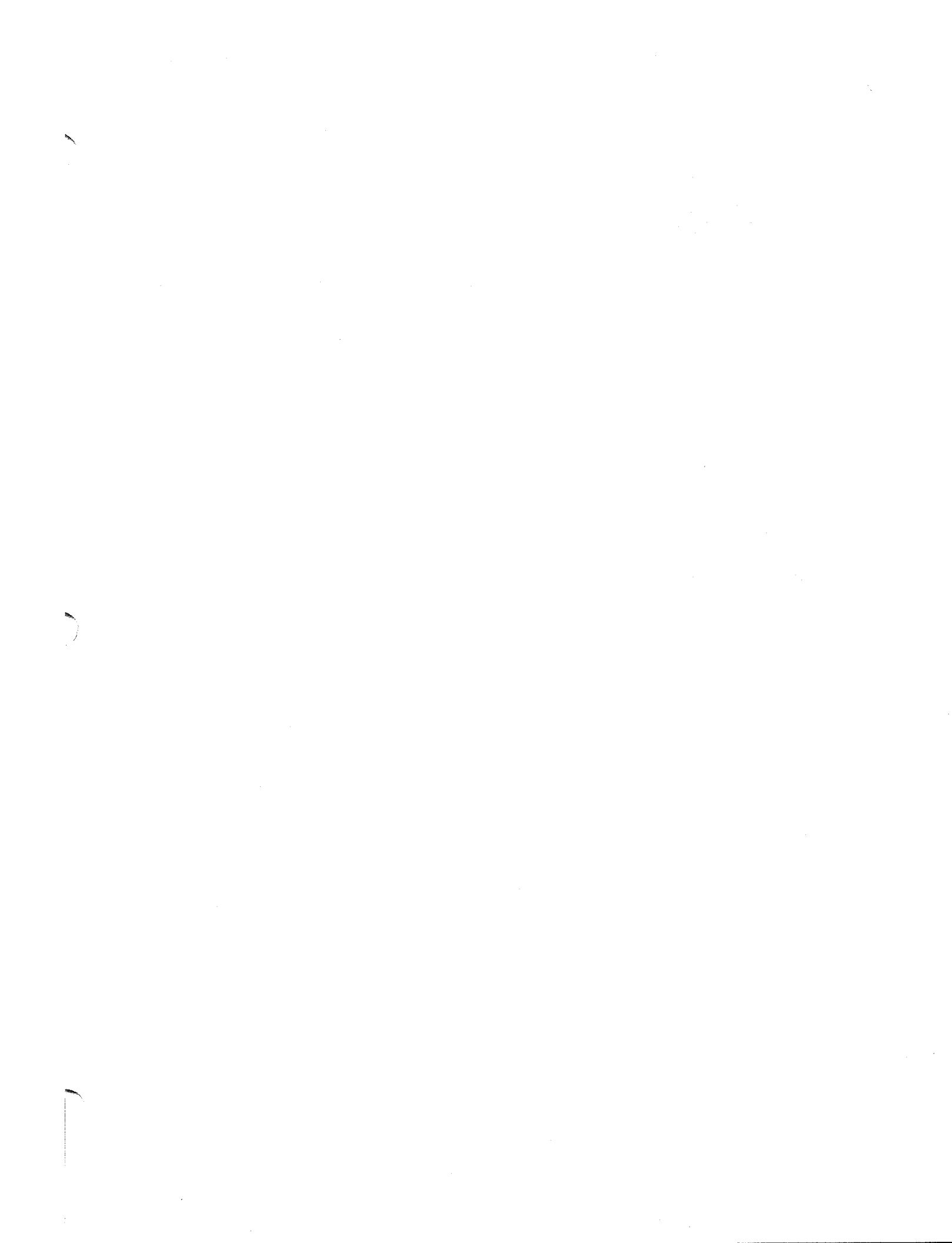

SEARS

**owner's
manual**

**MODEL NO.
247.886510**

**SEARS
SERVICE
is at
YOUR
SERVICE**

HOW TO ORDER REPAIR PARTS

Each SNOW THROWER has its own MODEL NUMBER.
Each ENGINE has its own MODEL NUMBER.

The MODEL NUMBER for the ENGINE will be found on the ENGINE BLOWER HOUSING.

Always mention these MODEL NUMBERS when requesting service or Repair Parts for your SNOW THROWER.

All parts listed herein may be ordered through any Sears Service Center/Departments and most Sears Stores.

WHEN ORDERING REPAIR PARTS, ALWAYS GIVE THE FOLLOWING INFORMATION:

1. PART NUMBER
2. PART DESCRIPTION
3. MODEL NUMBER — 247.886510
4. NAME OF THE ITEM — SNOW THROWER
5. ENGINE MODEL NUMBER —

"Your Sears merchandise has added value when you consider that Sears has service units nationwide staffed with Sears trained technicians... professional technicians specifically trained on Sears products, having the parts, tools and equipment to insure that we meet our pledge to you... we service what we sell."

Sold by Sears, Roebuck and Co., Chicago, IL 60684