

LXM32

Common DC bus Application note

MNA01M001EN, V1.01, 08.2014



The information provided in this documentation contains general descriptions and/or technical characteristics of the performance of the products contained herein. This documentation is not intended as a substitute for and is not to be used for determining suitability or reliability of these products for specific user applications. It is the duty of any such user or integrator to perform the appropriate and complete risk analysis, evaluation and testing of the products with respect to the relevant specific application or use thereof. Neither Schneider Electric nor any of its affiliates or subsidiaries shall be responsible or liable for misuse of the information contained herein. If you have any suggestions for improvements or amendments or have found errors in this publication, please notify us.

No part of this document may be reproduced in any form or by any means, electronic or mechanical, including photocopying, without express written permission of Schneider Electric.

All pertinent state, regional, and local safety regulations must be observed when installing and using this product. For reasons of safety and to help ensure compliance with documented system data, only the manufacturer should perform repairs to components.

When devices are used for applications with technical safety requirements, the relevant instructions must be followed.

Failure to use Schneider Electric software or approved software with our hardware products may result in injury, harm, or improper operating results.

Failure to observe this information can result in injury or equipment damage.

© 2013 Schneider Electric. All rights reserved.

Table of contents



Table of contents	3
Safety Information	5
Hazard categories	5
Qualification of personnel.....	6
Intended use	6
Basic information.....	7
DC bus voltage measurement.....	9
Standards and terminology.....	9
About the book	11
1 Introduction	13
1.1 Permissible device types for common DC bus.....	14
2 Technical Data	15
2.1 Firmware version.....	15
2.2 DC bus data.....	16
2.3 Braking resistor.....	17
2.3.1 External braking resistors (accessories).....	19
2.4 Cables for the DC bus.....	20
3 Engineering	21
3.1 Energy balance.....	22
3.1.1 Energy balance basics.....	22
3.2 Electromagnetic compatibility (EMC).....	24
3.3 DC bus connection.....	24
3.4 Fuses.....	25
3.4.1 DC bus connection of single-phase drives.....	25
3.4.2 DC bus connection of three-phase drives.....	27
3.4.3 Supply via the DC bus	29
3.5 Braking resistors.....	32
3.5.1 Rating the braking resistor.....	32
3.5.2 Rating information	34
3.6 Mains reactor	36
3.7 Mains filter.....	38
3.8 Mains reactor and external mains filter.....	39
4 Installation	41

4.1	Assembling cables	42
4.2	Wiring the DC bus	45
4.2.1	Drives with connectors.....	45
4.2.2	Drives with terminals.....	47
4.2.3	Connecting the DC bus.....	48
4.3	Verifying installation.....	49
5	Commissioning	51
5.1	Commissioning procedure.....	52
5.1.1	DC bus connection LXM32 to LXM32	52
5.1.2	Supply via the DC bus	53
5.2	LXM32: Setting the braking resistor parameters.....	54
6	Accessories and spare parts	55
6.1	DC bus accessories	55
6.2	DC fuses.....	55
6.3	External braking resistors.....	56
	Glossary	57
	Units and conversion tables	57
	Length.....	57
	Mass.....	57
	Force.....	57
	Power.....	57
	Rotation.....	58
	Torque.....	58
	Moment of inertia.....	58
	Temperature.....	58
	Conductor cross section	58
	Terms and Abbreviations	59
	Table of figures	61
	Index	63

Safety Information



Read these instructions carefully, and look at the equipment to become familiar with the device before trying to install, operate, or maintain it. The following special messages may appear throughout this documentation or on the equipment to warn of potential hazards or to call attention to information that clarifies or simplifies a procedure.



The addition of this symbol to a Danger safety label indicates that an electrical hazard exists, which will result in personal injury if the instructions are not followed.



This is the safety alert symbol. It is used to alert you to potential personal injury hazards. Obey all safety messages that follow this symbol to avoid possible injury or death.

Hazard categories

Safety instructions to the user are highlighted by safety alert symbols in the manual. In addition, labels with symbols and/or instructions are attached to the product that alert you to potential hazards.

Depending on the seriousness of the hazard, the safety instructions are divided into 4 hazard categories.

DANGER

DANGER indicates an imminently hazardous situation, which, if not avoided, **will result** in death or serious injury.

WARNING

WARNING indicates a potentially hazardous situation, which, if not avoided, **can result** in death, serious injury, or equipment damage.

CAUTION

CAUTION indicates a potentially hazardous situation, which, if not avoided, **can result** in injury or equipment damage.

NOTICE

NOTICE indicates a potentially hazardous situation, which, if not avoided, **can result** in equipment damage.

Qualification of personnel

Only appropriately trained persons who are familiar with and understand the contents of this manual and all other pertinent product documentation are authorized to work on and with this product. In addition, these persons must have received safety training to recognize and avoid hazards involved. These persons must have sufficient technical training, knowledge and experience and be able to foresee and detect potential hazards that may be caused by using the product, by changing the settings and by the mechanical, electrical and electronic equipment of the entire system in which the product is used.

All persons working on and with the product must be fully familiar with all applicable standards, directives, and accident prevention regulations when performing such work.

Intended use

The functions described in this document are only intended for use for the products described in this document.

The product may only be used in compliance with all applicable safety regulations and directives, the specified requirements and the technical data.

Prior to using the product, you must perform a risk assessment in view of the planned application. Based on the results, the appropriate safety measures must be implemented.

Since the product is used as a component in an entire system, you must ensure the safety of persons by means of the design of this entire system (for example, machine design).

Operate the product only with the specified cables and accessories. Use only genuine accessories and spare parts.

Any use other than the use explicitly permitted is prohibited and can result in hazards.

Electrical equipment should be installed, operated, serviced, and maintained only by qualified personnel.

Basic information

DANGER

HAZARD DUE TO ELECTRIC SHOCK, EXPLOSION OR ARC FLASH

- Only appropriately trained persons who are familiar with and understand the contents of this manual and all other pertinent product documentation and who have received safety training to recognize and avoid hazards involved are authorized to work on and with this drive system. Installation, adjustment, repair and maintenance must be performed by qualified personnel.
- The system integrator is responsible for compliance with all local and national electrical code requirements as well as all other applicable regulations with respect to grounding of all equipment.
- Many components of the product, including the printed circuit board, operate with mains voltage. Do not touch. Use only electrically insulated tools.
- Do not touch unshielded components or terminals with voltage present.
- The motor itself generates voltage when the motor shaft is rotated. Block the motor shaft to prevent rotation prior to performing any type of work on the drive system.
- AC voltage can couple voltage to unused conductors in the motor cable. Insulate both ends of unused conductors of the motor cable.
- Do not short across the DC bus terminals or the DC bus capacitors.
- Before performing work on the drive system:
 - Disconnect all power, including external control power that may be present.
 - Place a "Do Not Turn On" label on all power switches.
 - Lock all power switches in the open position.
 - **Wait 15 minutes** to allow the DC bus capacitors to discharge. Measure the voltage on the DC bus as per chapter "DC bus voltage measurement" and verify the voltage is <42 Vdc. The DC bus LED is not an indicator of the absence of DC bus voltage.
- Install and close all covers before applying voltage.

Failure to follow these instructions will result in death or serious injury.

⚠ WARNING**LOSS OF CONTROL**

- The designer of any control scheme must consider the potential failure modes of control paths and, for certain critical functions, provide a means to achieve a safe state during and after a path failure. Examples of critical control functions are emergency stop, overtravel stop, power outage and restart.
- Separate or redundant control paths must be provided for critical functions.
- System control paths may include communication links. Consideration must be given to the implication of unanticipated transmission delays or failures of the link.
- Observe all accident prevention regulations and local safety guidelines.¹⁾
- Each implementation of the product must be individually and thoroughly tested for proper operation before being placed into service.

Failure to follow these instructions can result in death, serious injury, or equipment damage.

1) For USA: Additional information, refer to NEMA ICS 1.1 (latest edition), "Safety Guidelines for the Application, Installation, and Maintenance of Solid State Control" and to NEMA ICS 7.1 (latest edition), "Safety Standards for Construction and Guide for Selection, Installation and Operation of Adjustable-Speed Drive Systems".

DC bus voltage measurement

The DC bus voltage can exceed 800 Vdc. The DC bus LED is not an indicator of the absence of DC bus voltage.

DANGER

ELECTRIC SHOCK, EXPLOSION OR ARC FLASH

- Disconnect the voltage supply to all connections.
- Wait 15 minutes to allow the DC bus capacitors to discharge.
- Use a properly rated voltage-sensing device for measuring (>800 Vdc).
- Measure the DC bus voltage between the DC bus terminals (PA/+ and PC/-) to verify that the voltage is less than 42 Vdc.
- Contact your local Schneider Electric representative if the DC bus capacitors do not discharge to less than 42 Vdc within a period of 15 minutes.
- Do not operate the product if the DC bus capacitors do not discharge properly.
- Do not attempt to repair the product if the DC bus capacitors do not discharge properly.

Failure to follow these instructions will result in death or serious injury.

Standards and terminology

Technical terms, terminology and the corresponding descriptions in this manual are intended to use the terms or definitions of the pertinent standards.

In the area of drive systems, this includes, but is not limited to, terms such as "safety function", "safe state", "fault", "fault reset", "failure", "error", "error message", "warning", etc.

Among others, these standards include:

- IEC 61800 series: "Adjustable speed electrical power drive systems"
- IEC 61158 series: "Digital data communications for measurement and control – Fieldbus for use in industrial control systems"
- IEC 61784 series: "Industrial communication networks – Profiles"
- IEC 61508 series: "Functional safety of electrical/electronic/programmable electronic safety-related systems"

Also see the glossary at the end of this manual.

About the book



This document describes how several Schneider Electric drives type LXM32 can share a common DC bus.

This application note replaces application note MNA01D001.

The information provided in this document supplements the manuals. Before beginning, fully read and understand the manuals of the products used.

Source manuals The latest versions of the manuals can be downloaded from the Internet at:

<http://www.schneider-electric.com>

Work steps If work steps must be performed consecutively, this sequence of steps is represented as follows:

- Special prerequisites for the following work steps
 - ▶ Step 1
 - ◁ Specific response to this work step
 - ▶ Step 2

If a response to a work step is indicated, this allows you to verify that the work step has been performed correctly.

Unless otherwise stated, the individual steps must be performed in the specified sequence.

Making work easier Information on making work easier is highlighted by this symbol:



Sections highlighted this way provide supplementary information on making work easier.

SI units Technical data are specified in SI units. Converted units are shown in parentheses behind the SI unit; they may be rounded.

Example:

Minimum conductor cross section: 1.5 mm² (AWG 14)

Glossary Explanations of special technical terms and abbreviations.

Index List of keywords with references to the corresponding page numbers.

1 Introduction

A drive system requires energy for acceleration or constant movement that must be supplied to the system.

During deceleration, a motor acts as a generator. A considerable portion of the kinetic energy is re-generated as electrical energy.

Since electrical energy can only be stored to a limited extent in a single drive, a drive uses a braking resistor to transform the excess energy into thermal energy.

Use of electrical energy If an application operates with multiple drive systems, it may be useful to employ a common DC bus. By sharing a common DC bus, the energy regenerated by one drive can be supplied to another drive.

Common DC bus Whether or not a common DC bus makes sense depends on the acceleration and deceleration cycles of the drive systems.

A common DC bus is useful, for example, if one drive systems accelerates while another drive system decelerates.

If the drive systems accelerate and decelerate at the same time, a common DC bus does not make sense.

1.1 Permissible device types for common DC bus

The DC bus of drives with identical numbers of mains phases can be connected.

Single-phase drives:

- LXM32••••M2 with LXM32••••M2

Three-phase drives:

- LXM32••••N4 with LXM32••••N4

2 Technical Data

2.1 Firmware version

A common DC bus requires the devices to have at least the specified firmware versions:

Drive	Firmware version
LXM32C, LXM32A	V01.04.00
LXM32M	V01.02.00

2.2 DC bus data

Single-phase drives

LXM32•...		U45M2		U90M2		D18M2		D30M2	
Nominal voltage (1 ~)	V	115	230	115	230	115	230	115	230
Nominal voltage DC bus	V	163	325	163	325	163	325	163	325
Undervoltage limit	V	55	130	55	130	55	130	55	130
Voltage limit: activation of Quick Stop	V	60	140	60	140	60	140	60	140
Overvoltage limit	V	450	450	450	450	450	450	450	450
Maximum continuous power via DC bus	kW	0.2	0.5	0.4	0.9	0.8	1.6	0.8	2.2
Maximum continuous current via DC bus	A	1.5	1.5	3.2	3.2	6.0	6.0	10.0	10.0

Three-phase drives

LXM32•...		U60N4	D12N4	D18N4	D30N4	D72N4	D85N4	C10N4
Nominal voltage (3 ~)	V	208	208	208	208	208	208	208
Nominal voltage DC bus	V	294	294	294	294	294	294	294
Undervoltage limit	V	150	150	150	150	150	150	150
Voltage limit: activation of Quick Stop	V	160	160	160	160	160	160	160
Overvoltage limit	V	820	820	820	820	820	820	820
Maximum continuous power via DC bus	kW	0.4	0.8	1.7	2.8	6.5	7.0	11.0
Maximum continuous current via DC bus	A	1.5	3.2	6.0	10.0	22.0	28.0	40.0

LXM32•...		U60N4	D12N4	D18N4	D30N4	D72N4	D85N4	C10N4
Nominal voltage (3 ~)	V	400	400	400	400	400	400	400
Nominal voltage DC bus	V	566	566	566	566	566	566	566
Undervoltage limit	V	350	350	350	350	350	350	350
Voltage limit: activation of Quick Stop	V	360	360	360	360	360	360	360
Overvoltage limit	V	820	820	820	820	820	820	820
Maximum continuous power via DC bus	kW	0.8	1.6	3.3	5.6	13.0	15.0	22.0
Maximum continuous current via DC bus	A	1.5	3.2	6.0	10.0	22.0	28.0	40.0

LXM32•...		U60N4	D12N4	D18N4	D30N4	D72N4	D85N4	C10N4
Nominal voltage (3 ~)	V	480	480	480	480	480	480	480
Nominal voltage DC bus	V	679	679	679	679	679	679	679
Undervoltage limit	V	350	350	350	350	350	350	350
Voltage limit: activation of Quick Stop	V	360	360	360	360	360	360	360
Overvoltage limit	V	820	820	820	820	820	820	820
Maximum continuous power via DC bus	kW	0.8	1.6	3.3	5.6	13.0	15.0	22.0
Maximum continuous current via DC bus	A	1.5	3.2	6.0	10.0	22.0	28.0	40.0

2.3 Braking resistor

LXM32 drives have an internal braking resistor and a connection for an external braking resistor. If the internal braking resistor is insufficient for the dynamics of the application, one or more external braking resistors must be connected.

Single-phase drives

LXM32•...		U45M2	U90M2	D18M2	D30M2
Resistance value of internal braking resistor	Ω	94	47	20	10
Continuous power internal braking resistor P_{PR}	W	10	20	40	60
Peak energy E_{CR}	Ws	82	166	330	550
External braking resistor minimum	Ω	68	36	20	10
External braking resistor maximum ¹⁾	Ω	110	55	27	16
Maximum continuous power external braking resistor	W	200	400	600	800
Capacitance of internal capacitor	μF	390	780	1170	1560
Parameter DCbus_compat = 0 (default value)					
Switch-on voltage braking resistor	V	430	430	430	430
Energy absorption of internal capacitors E_{var} at nominal voltage 115 V +10%	Ws	30	60	89	119
Energy absorption of internal capacitors E_{var} at nominal voltage 200 V +10%	Ws	17	34	52	69
Energy absorption of internal capacitors E_{var} at nominal voltage 230 V +10%	Ws	11	22	33	44
Parameter DCbus_compat = 1 (reduced switch-on voltage)					
Switch-on voltage braking resistor	V	395	395	395	395
Energy absorption of internal capacitors E_{var} at nominal voltage 115 V +10%	Ws	24	48	73	97
Energy absorption of internal capacitors E_{var} at nominal voltage 200 V +10%	Ws	12	23	35	46
Energy absorption of internal capacitors E_{var} at nominal voltage 230 V +10%	Ws	5	11	16	22

1) The maximum specified braking resistor can derate the peak power of the device. Depending on the application, it is possible to use a higher ohm resistor.

Three-phase drives

LXM32•...		U60N4	D12N4	D18N4	D30N4	D72N4	D85N4	C10N4
Resistance value of internal braking resistor	Ω	132	60	30	30	10	10	10
Continuous power internal braking resistor P _{PR}	W	20	40	60	100	150	150	150
Peak energy E _{CR}	Ws	200	400	600	1000	2400	2400	2400
External braking resistor minimum	Ω	70	47	25	15	8	8	8
External braking resistor maximum ¹⁾	Ω	145	73	50	30	12	11	11
Maximum continuous power external braking resistor	W	200	500	800	1500	3000	4500	5500
Capacitance of internal capacitor	μF	110	195	390	560	1120	1230	1230
Parameter DCbus_compat ²⁾								
Switch-on voltage	V	780	780	780	780	780	780	780
Energy absorption of internal capacitors E _{var} at nominal voltage 208 V +10%	Ws	28	49	98	141	282	310	310
Energy absorption of internal capacitors E _{var} at nominal voltage 380 V +10%	Ws	14	25	50	73	145	159	159
Energy absorption of internal capacitors E _{var} at nominal voltage 400 V +10%	Ws	12	22	43	62	124	136	136
Energy absorption of internal capacitors E _{var} at nominal voltage 480 V +10%	Ws	3	5	10	14	28	31	31

1) The maximum specified braking resistor can derate the peak power of the device. Depending on the application, it is possible to use a higher ohm resistor.

2) Parameter DCbus_compat has no effect in the case of three-phase devices

2.3.1 External braking resistors (accessories)

The resistance values for external braking resistors must not be below the minimum resistance specified for the drives.

VW3A760...		1Rxx ¹⁾	2Rxx	3Rxx	4Rxx ¹⁾	5Rxx	6Rxx	7Rxx ¹⁾
Resistance	Ω	10	27	27	27	72	72	72
Continuous power	W	400	100	200	400	100	200	400
Maximum time in braking at 115 V / 230 V	s	0.72	0.552	1.08	2.64	1.44	3.72	9.6
Peak power at 115 V / 230 V	kW	18.5	6.8	6.8	6.8	2.6	2.6	2.6
Maximum peak energy at 115 V / 230 V	Ws	13300	3800	7400	18100	3700	9600	24700
Maximum time in braking at 400 V / 480 V	s	0.12	0.084	0.216	0.504	0.3	0.78	1.92
Peak power at 400 V / 480 V	kW	60.8	22.5	22.5	22.5	8.5	8.5	8.5
Maximum peak energy at 400 V / 480 V	Ws	7300	1900	4900	11400	2500	6600	16200
Degree of protection		IP65	IP65	IP65	IP65	IP65	IP65	IP65
UL approval (file no.)		-	E233422	E233422	-	E233422	E233422	-

1) Resistors with a continuous power of 400 W are not UL/CSA-approved.

VW3A77...		04	05
Resistance	Ω	15	10
Continuous power	W	1000	1000
Maximum time in braking at 115 V / 230 V	s	3.5	1.98
Peak power at 115 V / 230 V	kW	12.3	18.5
Maximum peak energy at 115 V / 230 V	Ws	43100	36500
Maximum time in braking at 400 V / 480 V	s	0.65	0.37
Peak power at 400 V / 480 V	kW	40.6	60.8
Maximum peak energy at 400 V / 480 V	Ws	26500	22500
Degree of protection		IP20	IP20
UL approval (file no.)		E221095	E221095

2.4 Cables for the DC bus

Minimum requirement A cable for the common DC bus must meet the following requirements.

Shield:	Shielded at cable lengths of > 0.2 m
Twisted Pair:	Twisted pair at cable lengths of > 0.2 m
Cable:	Two wires, shielded
Maximum cable length between 2 drives:	3 m
Special characteristics:	<ul style="list-style-type: none"> • Insulation must be rated for the DC bus voltage • Conductor cross section according to the calculated current, but at least 2* 6 mm² (2* AWG 10)

The connection of the fuses for the DC bus must be rated for the total maximum continuous current on the DC bus of all drives connected via the DC bus. Analyze the most critical case in your application (for example EMERGENCY STOP) and select an appropriate conductor cross section.

3 Engineering

This chapter provides engineering information for a common DC bus for several drives.

Incorrect use of the DC bus may permanently damage the drives either immediately or over time.

WARNING

DESTRUCTION OF SYSTEM COMPONENTS AND LOSS OF CONTROL

Verify that all requirements for using the DC bus are met.

Failure to follow these instructions can result in death, serious injury, or equipment damage.

WARNING

DESTRUCTION OF SYSTEM COMPONENTS

- Connect only drives with identical nominal voltages.
- Connect single-phase drives only to single-phase drives. Connect single-phase drives to the same phase.
- Connect three-phase drives only to three-phase drives.

Failure to follow these instructions can result in death, serious injury, or equipment damage.

LXM32: See the Engineering chapter in the LXM32 product manual for vital engineering information concerning the LXM32 drive.

3.1 Energy balance

To be able to estimate the effect of an interconnection of drives via a common DC bus, create an energy balance of the individual drives over a movement cycle. A movement cycle typically consists of the following phases: acceleration, continuous movement and deceleration.

The energy generated during deceleration can be used by other drives connected via a common DC bus. Excess energy can be absorbed by the braking resistors.

The assessment of the energy balances of the individual drives per movement cycle and of the cyclic sequence of the movement cycles allows you to draw a conclusion regarding the efficiency of a common DC bus.

3.1.1 Energy balance basics

The energy balance is influenced by the following factors:

- Energy absorption of capacitors E_{var} in the drive
- Electrical losses of the drive system E_{el}
- Mechanical losses of the facility and the drive system E_{mech}
- Braking resistor E_B

Energy absorption of the capacitors E_{var}

The higher the mains voltage, the lower the energy absorption of the capacitors E_{var} . In your calculation, use the values for the highest mains voltage that is used in your application, see chapter "2.3 Braking resistor".

The energy absorption of the capacitors E_{var} is the square difference between the voltage prior to the start of the deceleration and the switch-on voltage of the braking resistor.

Electrical losses E_{el}

The electrical losses E_{el} of the drive system can be estimated on the basis of the peak power of the drive. The maximum power dissipation is approximately 10% of the peak power at a typical efficiency of 90%. If the current during deceleration is lower, the power dissipation is reduced accordingly.

Mechanical losses E_{mech}

The mechanical losses result from friction during operation of the system. Mechanical losses are negligible if the time required by the system to coast to a stop without a driving force is considerably longer than the time required to decelerate the system. The mechanical losses can be calculated from the load torque and the velocity from which the motor is to stop.

Braking resistor E_B

Two characteristic values determine the energy absorption of a braking resistor:

- The continuous power P_{PR} is the amount of energy that can be continuously absorbed without overloading the braking resistor.
- The maximum energy E_{CR} limits the maximum short-term power that can be absorbed.

Rating

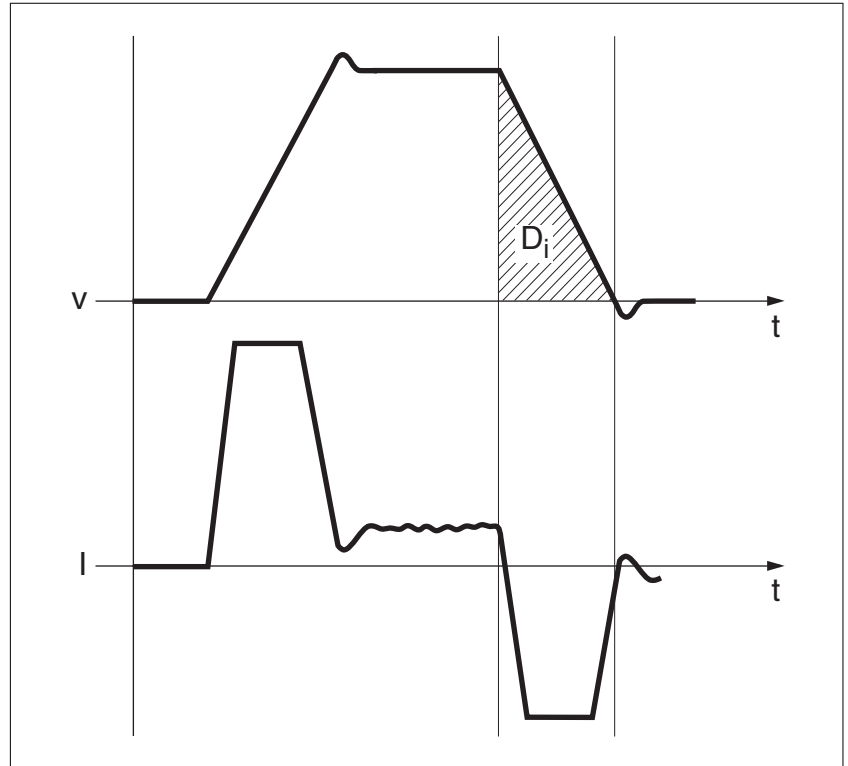

Figure 1: Movement cycle: Profile for energy assessment

This profile with velocity (v) and motor current (I) is also used for rating the motor and the braking resistor. The deceleration segment to be considered is labeled D_i .

Calculation of the energy at constant deceleration:

The total inertia (J_t) must be known.

J_t with:

$$J_t = J_m + J_c$$

J_m : Motor inertia with or without holding brake

J_c : Load inertia

The energy for each deceleration segment is calculated as follows:

$$E_i = \frac{1}{2} J_t \cdot \omega_i^2 = \frac{1}{2} J_t \cdot \left[\frac{2\pi n_i}{60} \right]^2$$

Units: E_i in Ws (wattseconds), J_t in kgm^2 , ω in rad and n_i in min^{-1} .

See the technical data for the energy absorption E_{var} of the devices (without consideration of an internal or external braking resistor).

In the next calculation steps, only consider those segments D_i , whose energy E_i exceeds the energy absorption of the device (see chapter "2.2 DC bus data"). These excess energies E_{Di} must be diverted by means of the braking resistor (internal or external).

E_{Di} is calculated using the following formula:

$$E_{Di} = E_i - E_{var} \text{ (in Ws)}$$

The continuous power P_c is calculated for each machine cycle:

$$P_c = \frac{\sum E_{Di}}{\text{Cycletime}}$$

Units: P_c in W, E_{Di} in Ws and cycle time T in s

These calculations allow you to select the required braking resistor.

3.2 Electromagnetic compatibility (EMC)

If drives are to be operated via a common DC bus, the following aspects must be considered in terms of EMC:

- Keep DC bus cables as short as possible.
- Shielded DC bus cables must be used at a cable length of > 0.2 m. In the case of shielded DC bus cables, connect the cable shield to the shield connection (large surface area contact).

3.3 DC bus connection

The DC bus is connected by means of a plug and socket connection or screw terminals.

See the manual of the respective product for tightening torque of the screw terminals.

Cable specifications See chapter "2.4 Cables for the DC bus", page 20 for the cable specifications. Connector kits and pre-assembled cables can be found in chapter "6 Accessories and spare parts", page 55.

3.4 Fuses

The number of mains fuses depends on the input current of all drives connected via the common DC bus.

Choose fuse ratings as low as possible according to the power of the drive as well as the conductor cross section.

See manual of the respective product for more information.

The maximum permissible fuse ratings must not be exceeded.

3.4.1 DC bus connection of single-phase drives

Single mains fuse A single mains fuse is sufficient if the total input current of all drives connected via the common DC bus is less than the maximum fuse rating shown in the table below.

Single mains fuse		Maximum fuse rating
LXM32••••M2	A	25

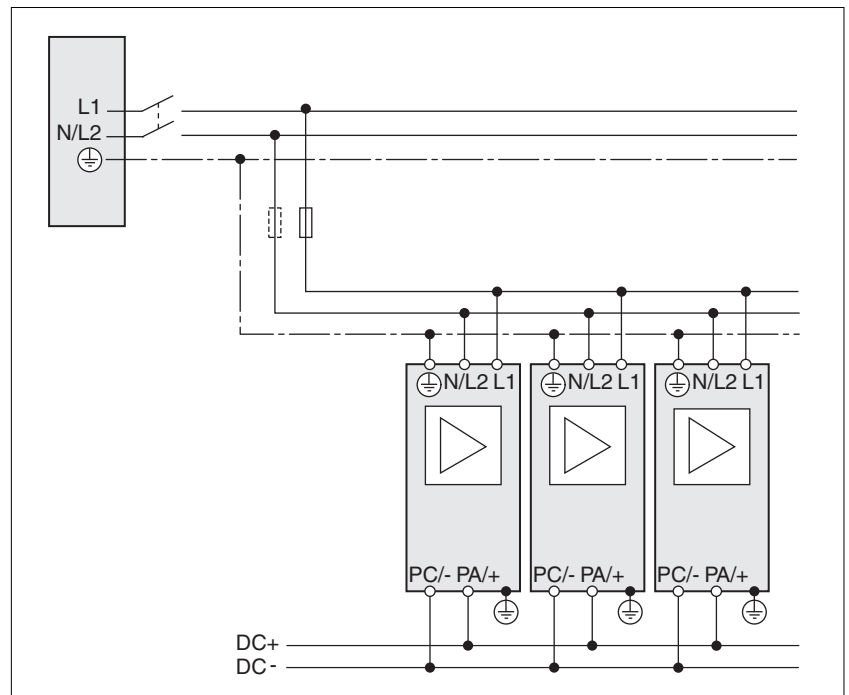

Figure 2: Single mains fuse for single-phase drives

Multiple mains fuses

Multiple mains fuses are required if the total input current of all drives connected via the common DC bus exceeds the maximum fuse rating shown in the table below.

Multiple mains fuses		Maximum fuse rating
LXM32••••M2	A	25

If multiple mains fuses are required, additional DC bus fuses must be used upstream of each drive. The DC bus fuses must be suitable for 600 Vdc.

DC bus fuses		Maximum fuse rating
LXM32••••M2	A	25

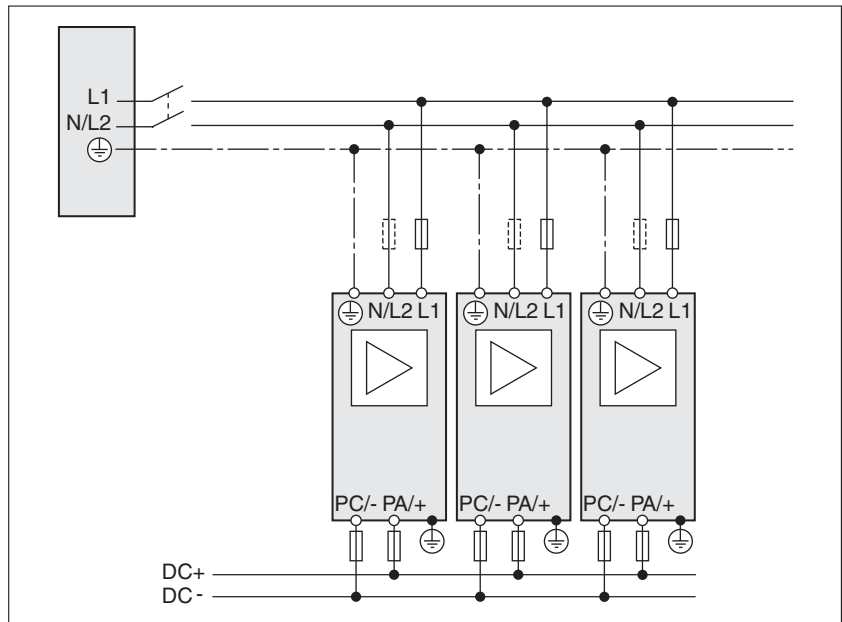

Figure 3: Multiple mains fuses for single-phase drives

See chapter "6.2 DC fuses" for fuses for the DC bus.



The use of mains reactors can reduce the input current. Due to the lower input current, it may be possible to operate the drives with just a single mains fuse.

3.4.2 DC bus connection of three-phase drives

Single mains fuse A single fuse is sufficient if the total input current of all drives connected via the common DC bus is less than the maximum fuse rating shown in the table below.

Single mains fuse		Maximum fuse rating
LXM32•U60N4, LXM32•D12N4, LXM32•D18N4, LXM32•D30N4, LXM32•D72N4	A	32
LXM32•D85N4, LXM32•C10N4	A	63

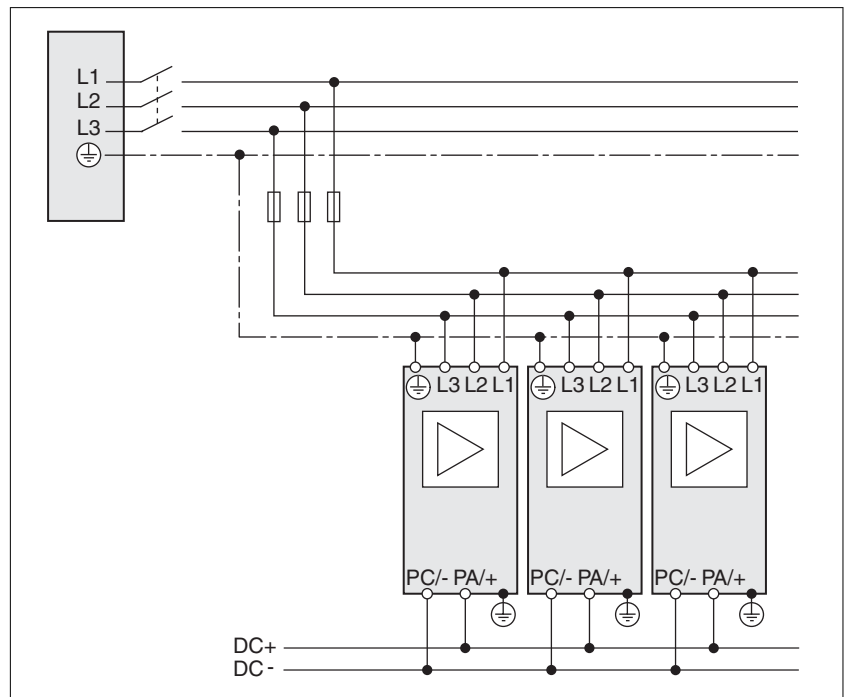

Figure 4: Single mains fuse for three-phase drives

Multiple mains fuses

Multiple mains fuses are required. A single fuse is sufficient if the total input current of all drives connected via the common DC bus is less than the maximum fuse rating shown in the table below.

Multiple mains fuses		Maximum fuse rating
LXM32•U60N4, LXM32•D12N4, LXM32•D18N4, LXM32•D30N4, LXM32•D72N4	A	32
LXM32•D85N4, LXM32•C10N4	A	63

If multiple mains fuses are required, additional DC bus fuses must be used upstream of each drive. The DC bus fuses must be suitable for 600 Vdc.

DC bus fuses		Maximum fuse rating
LXM32•U60N4, LXM32•D12N4, LXM32•D18N4, LXM32•D30N4, LXM32•D72N4	A	32
LXM32•D85N4, LXM32•C10N4	A	63

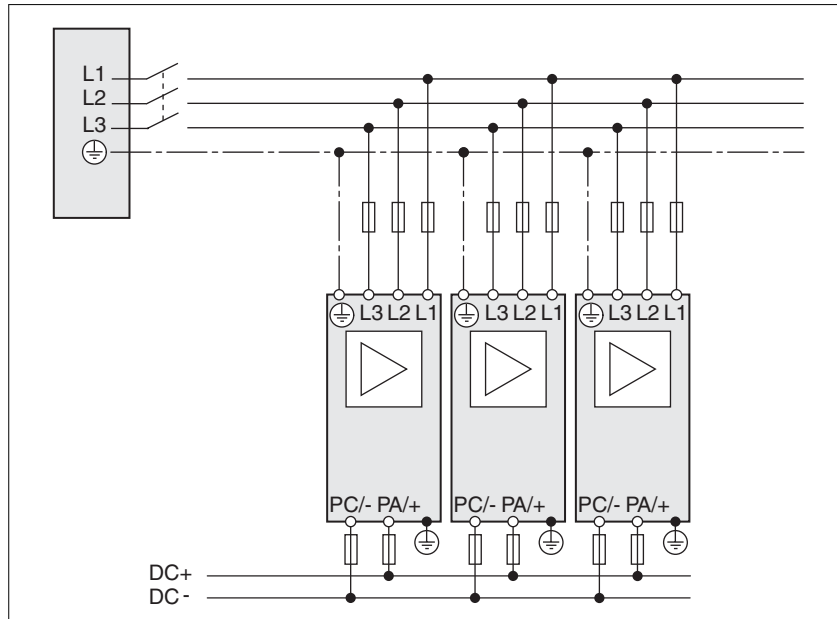

Figure 5: Multiple mains fuses for three-phase drives

See chapter "6.2 DC fuses" for fuses for the DC bus.



The use of mains reactors can reduce the input current. Due to the lower input current, it may be possible to operate the drives with just a single mains fuse.

3.4.3 Supply via the DC bus

A single or multiple drives can be supplied directly via the DC bus.

The supply is provided by a correspondingly sized drive or by a DC power supply unit.

In the case of supply via the DC bus, DC bus fuses must be used. The DC bus fuses must be suitable for 600 Vdc.

The number of DC bus fuses depends on the total maximum continuous current on the DC bus of all drives connected via the common DC bus.

Single-phase drives

DC bus fuses		Maximum fuse rating
LXM32••••M2	A	25

Three-phase drives

DC bus fuses		Maximum fuse rating
LXM32•U60N4, LXM32•D12N4, LXM32•D18N4, LXM32•D30N4, LXM32•D72N4	A	32
LXM32•D85N4, LXM32•C10N4	A	63

Single DC bus fuse If the total maximum continuous current on the DC bus of all drives connected via the common DC bus does not exceed the maximum fuse rating of a drive, a single DC bus fuse is sufficient.

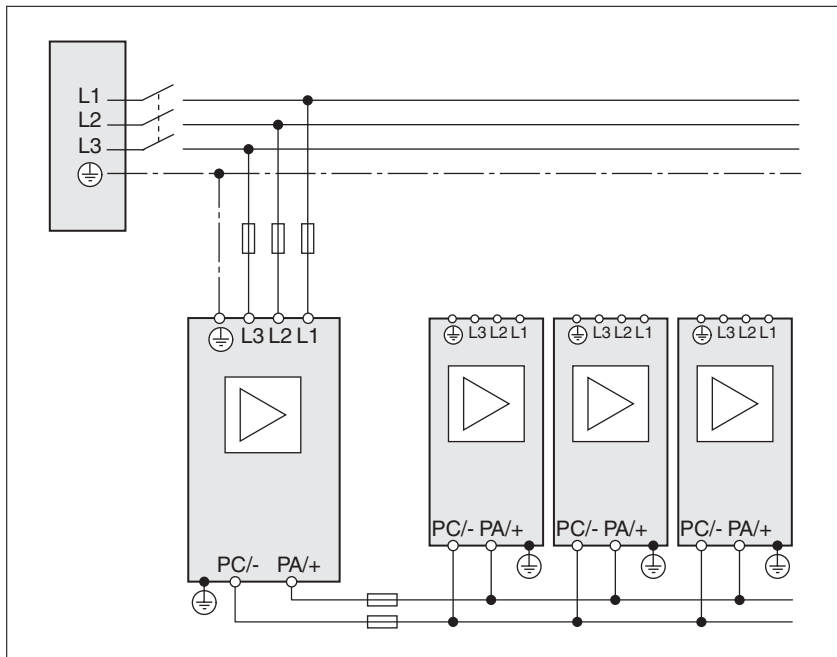

Figure 6: Supply via the DC bus by a drive

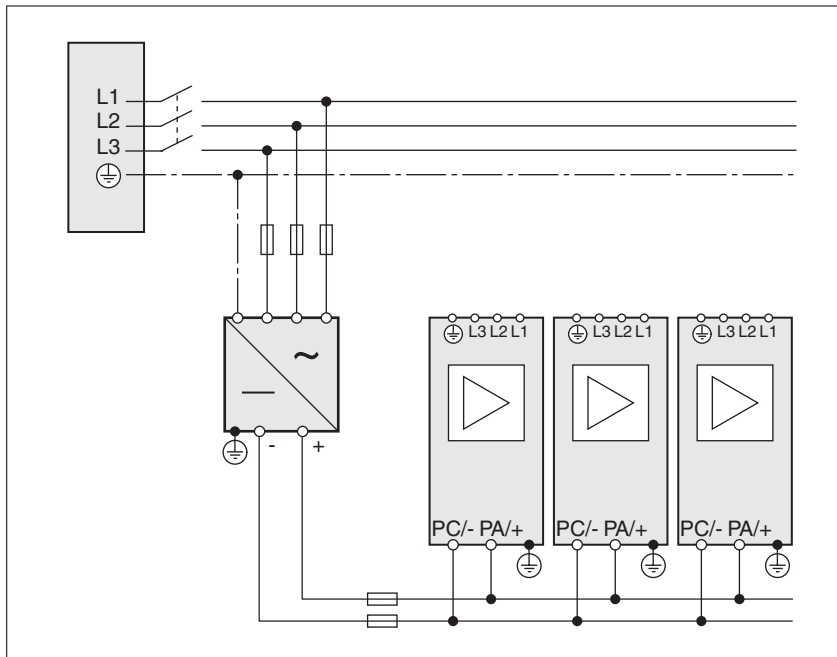

Figure 7: Supply via the DC bus by a DC power supply unit

Multiple DC bus fuses

If the total maximum continuous current on the DC bus of all drives connected via the common DC bus exceeds the maximum fuse rating of a drive, DC bus fuses are required at each drive.

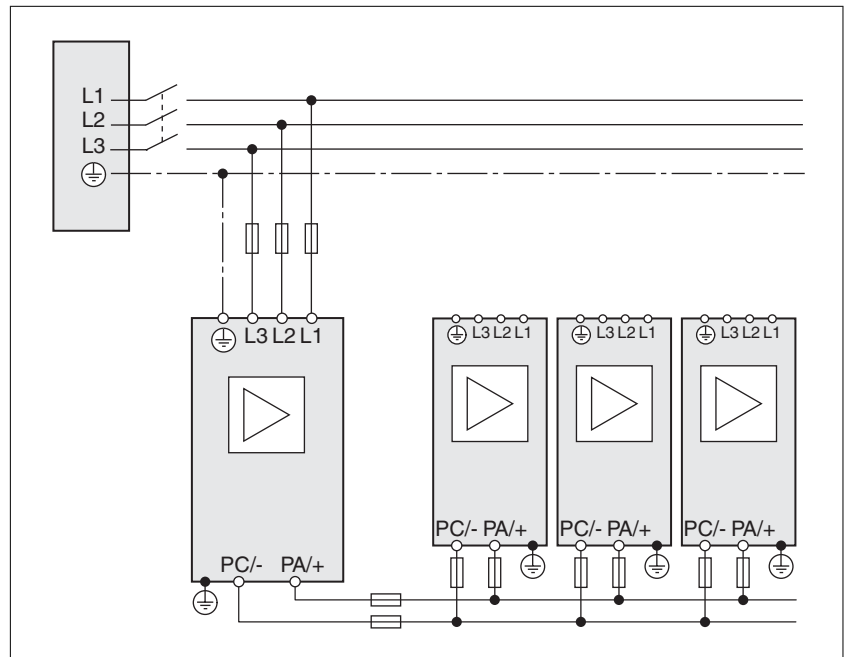

Figure 8: Supply via the DC bus by a drive

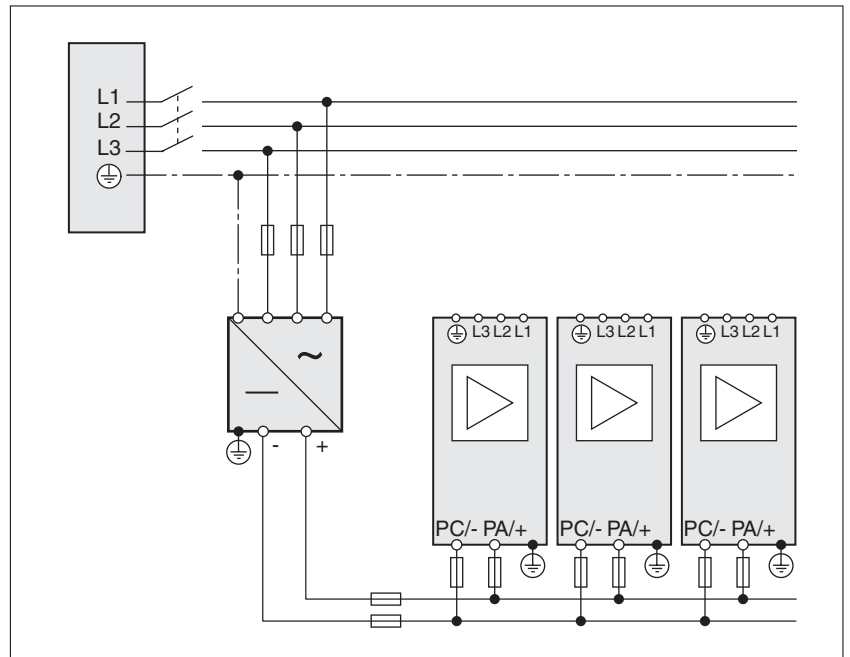

Figure 9: Supply via the DC bus by a DC power supply unit

3.5 Braking resistors

Excess energy in the common DC bus must be absorbed by the braking resistors. Depending on the application, one or more braking resistors can be connected. Consider the internal braking resistors of LXM32 drives in your calculations.

If drives with a different nominal power are connected via the DC bus, you must connect braking resistors to the drive with the highest nominal power. See the manual of the respective product for more information.

3.5.1 Rating the braking resistor

An insufficiently rated braking resistor can cause overvoltage on the DC bus. Overvoltage on the DC bus causes the power stage to be disabled. The motor is no longer actively decelerated.

⚠ WARNING
MOTOR WITHOUT BRAKING EFFECT
<ul style="list-style-type: none"> • Verify that the braking resistor has a sufficient rating. • Verify that the parameter settings for the braking resistor are correct. • Verify that the I²t value for temperature monitoring does not exceed 100% by performing a test run under maximum load conditions. • Verify that the calculations and the test run take into account the fact that the DC bus capacitors can absorb less braking energy at higher mains voltages.
Failure to follow these instructions can result in death, serious injury, or equipment damage.

The temperature of the braking resistor may exceed 250 °C (482 °F) during operation.

⚠ WARNING
HOT SURFACES
<ul style="list-style-type: none"> • Ensure that any contact with a hot braking resistor is avoided. • Do not allow flammable or heat-sensitive parts in the immediate vicinity of the braking resistor. • Verify that the heat dissipation is sufficient by performing a test run under maximum load conditions.
Failure to follow these instructions can result in death, serious injury, or equipment damage.

Braking resistors are required for dynamic applications. During deceleration, the kinetic energy is transformed into electrical energy in the motor. The electrical energy increases the DC bus voltage. The braking resistor is activated when the defined threshold value is exceeded. The braking resistor transforms electrical energy into heat. If highly dynamic deceleration is required, the braking resistor must be well adapted to the system.

Further information on the subject	Page
Technical data chapter "2.3 Braking resistor"	17
Commissioning chapter "5.2 LXM32: Setting the braking resistor parameters"	54

See also chapter "3.1 Energy balance", page 22 for rating information.

Internal braking resistor

A braking resistor to absorb braking energy is integrated in LXM32 drives. The device is shipped with the internal braking resistor active.

If the braking energy of all drives sharing a common DC bus is greater than the energy the internal braking resistors can absorb, you must use an external braking resistor. Consider the most extreme case of your application in calculating the braking energy.

Example: In the case of an EMERGENCY STOP, all drives decelerate simultaneously; the braking resistors must be able to absorb the entire braking energy.

External braking resistor

An external braking resistor is required in applications in which the braking energy is greater than the energy that can be absorbed by the drives sharing a common DC bus. Consider the most extreme case of your application in calculating the braking energy.

Example: In the case of an EMERGENCY STOP, all drives decelerate simultaneously; the braking resistors must be able to absorb the entire braking energy.

LXM32: Monitoring

LXM32 drives monitor the load on the connected braking resistor. The load on the braking resistor can be read out.

The connection of the external braking resistor is short-circuit protected. A ground fault of the braking resistor is not detected.

Selection of the external braking resistor

The rating of an external braking resistor depends on the required peak power and continuous power with which the braking resistor can be operated.

The resistance R is derived from the required peak power and the DC bus voltage.

$$R = \frac{U^2}{P_{\max}}$$

R = Resistance value in Ω

U = Switch-on voltage braking resistor in V

P_{\max} = Required peak power in W

If 2 or more braking resistors are connected to one drive, note the following criteria:

- The braking resistors must be connected in parallel or in series so the required resistance is reached. Only connect resistors with identical resistance in parallel in order to evenly distribute the load to all braking resistors.
- The total resistance of all external braking resistors connected to one drive must not fall below a lower limit.
- The continuous power of the network of connected braking resistors must be calculated. The result must be greater than or equal to the actually required continuous power.

Connection of braking resistor

Use only resistors that are specified as braking resistors. See chapter "2.3 Braking resistor", page 17 for suitable braking resistors.

Braking resistors with degree of protection IP65 may be installed outside the control cabinet in an appropriate environment in order to decrease the temperature in the control cabinet.

The external braking resistors listed in the Accessories chapter are shipped with an information sheet that provides details on installation.

Further procedure:

- Connect the braking resistors to the drive.
- LXM32: Check the parameter `RESint_ext` during commissioning. This parameter allows you to switch between internal and external braking resistor.
- LXM32: If you have connected an external braking resistor to an LXM32 drive, you must set the parameters for the external braking resistor during commissioning.
- During commissioning, test the braking resistors under realistic conditions, see page 54.



Wire ferrules: If you use wire ferrules, use only wire ferrules with collars for these terminals.

3.5.2 Rating information

To rate the braking resistor, calculate the proportion contributing to absorbing braking energy.

An external braking resistor is required if the kinetic energy that must be absorbed exceeds the total of the internal proportions, including the internal braking resistor.

The energy E_{var} is the square difference between the voltage before the deceleration process and the response threshold.

The voltage prior to the deceleration process depends on the mains voltage. The energy absorption by the DC bus capacitors is lowest when the mains voltage is highest. In the calculation, use the values for the highest mains voltage.

Energy absorption braking resistor

Two characteristic values determine the energy absorption of the braking resistor:

- The continuous power P_{PR} is the amount of energy that can be continuously absorbed without overloading the braking resistor.
- The maximum energy E_{CR} limits the maximum short-term power that can be absorbed.

If the continuous power was exceeded for a specific time, the braking resistor must remain without load for a corresponding period.

The characteristic values P_{PR} and E_{CR} of the internal braking resistor can be found in chapter "2 Technical Data".

See page 22 for information on assessing the electrical and mechanical losses.

Example: LXM32 drive

Deceleration of a rotary motor with the following data:

- Initial speed of rotation: $n = 4000 \text{ min}^{-1}$
- Rotor inertia: $J_R = 4 \text{ kgcm}^2$
- Load inertia: $J_L = 6 \text{ kgcm}^2$

Calculation of the energy to be absorbed:

$$E_B = 1/2 * J * (2*\pi*n * 1/60)^2$$

to 88 Ws

Electrical and mechanical losses are ignored.

In this example, the DC bus capacitors absorb 23 Ws (the value depends on the device type, see chapter "2 Technical Data").

The internal braking resistor must absorb the remaining 65 Ws. It can absorb a pulse of 80 Ws. If the load is decelerated once, the internal braking resistor is sufficient.

If the deceleration process is repeated cyclically, the continuous output must be considered. If the cycle time is longer than the ratio of the energy to be absorbed E_B and the continuous power P_{PR} , the internal braking resistor is sufficient. If the system decelerates more frequently, the internal braking resistor is not sufficient.

In the example, the ratio E_B/P_{PR} is 1.3 s. If the cycle time is shorter, an external braking resistor is required.

Selecting an external braking resistor

The selection is made in two steps:

- The maximum energy during deceleration must be less than the peak energy that the internal braking resistor can absorb: $(E_{Di}) < (E_{Cr})$. In addition, the continuous power of the internal braking resistor must not be exceeded: $(P_C) < (P_{Pr})$. If these conditions are met, then the internal braking resistor is sufficient.
- If one of the conditions is not met, you must use an external braking resistor. The braking resistor must be rated in such a way that the conditions are met. The resistance of the braking resistor must be between the specified minimum and maximum values, since otherwise the load can no longer be decelerated or the product might be destroyed.

See chapter "2.3 Braking resistor", page 17 for technical data on the external braking resistors.

3.6 Mains reactor

A mains reactor is required if at least one of the following criteria is met:

- The output power of the drive is to be increased.
- The short-circuit current rating (SCCR) of the supplying mains is greater than specified for the drives.
- Current harmonics are to be reduced.

If one drive requires a mains reactor, then all drives connected via the DC bus must be equipped with mains reactors.

The mains reactor for several drives with a common AC fuse must be rated in such a way that the nominal current of the mains reactor is greater than the total of the input current of the drives.

The fuse rating of the fuse upstream of the mains reactor must not be greater than the nominal current of the mains reactor.

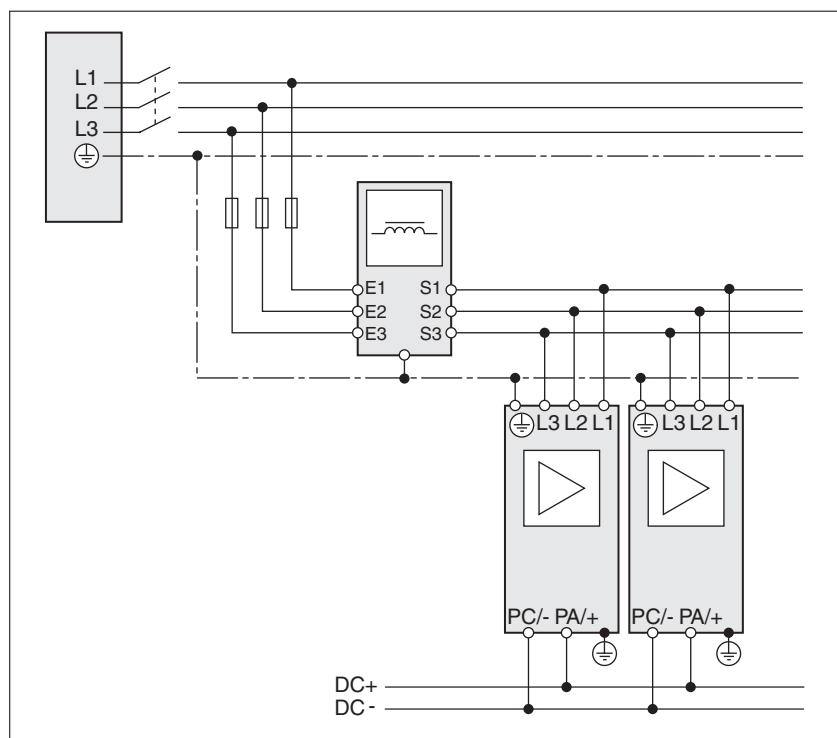

Figure 10: Wiring of drives with common AC fuse and a mains reactor, example shows three-phase drives.

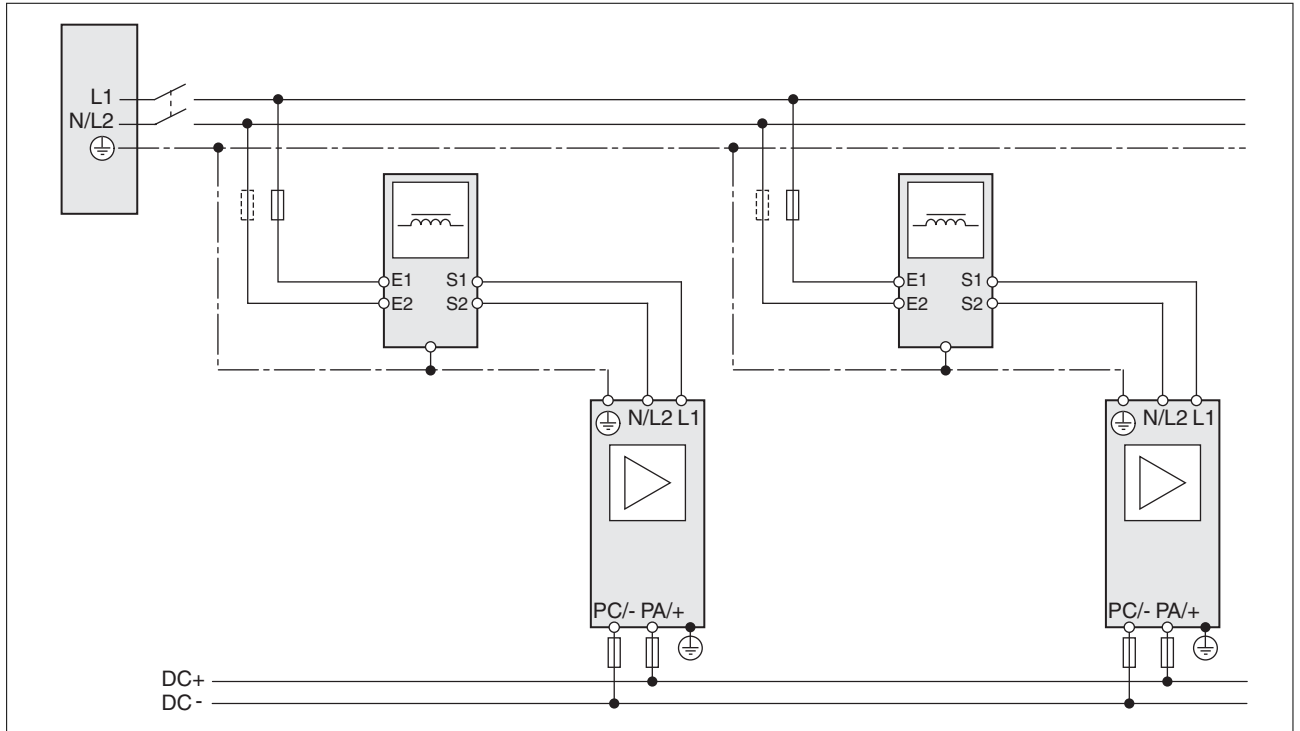

Figure 11: Wiring of drives with individual AC fuses and mains reactors, example shows single-phase drives.

See the manual of the respective product for information on mains reactors.

3.7 Mains filter

The emission depends on the length of the motor cables. If the required limit value is not reached with the internal mains filter, you must use an external mains filter.

See manual of the respective product for information on mains filters.

The mains filter for several drives with a common AC fuse must be rated in such a way that the nominal current of the external mains filter is greater than the total of the input current of the drives.

The fuse rating of the fuse upstream of the external mains filter must not be greater than the nominal current of the external mains filter.

Mount the external mains filter in such a way that the lines from the mains filter to the drives are as short as possible. For EMC reasons, route the cables from the mains filter to the drives separately from the line to the mains filter.

External three-phase mains filters do not have a neutral conductor connection; they are only approved for three-phase devices.

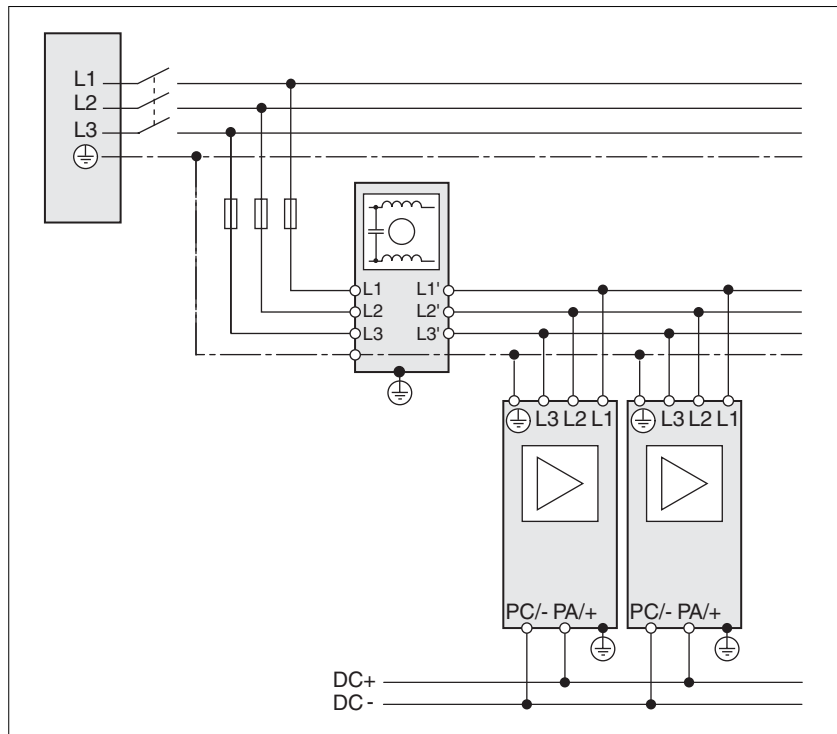

Figure 12: Wiring of an external mains filter, example shows three-phase drives.

See the manual of the respective product for information on external mains filters.

3.8 Mains reactor and external mains filter

If a mains reactor and an external mains filter are required, the mains reactor and external mains filter must be arranged according to the following illustrations for EMC reasons.

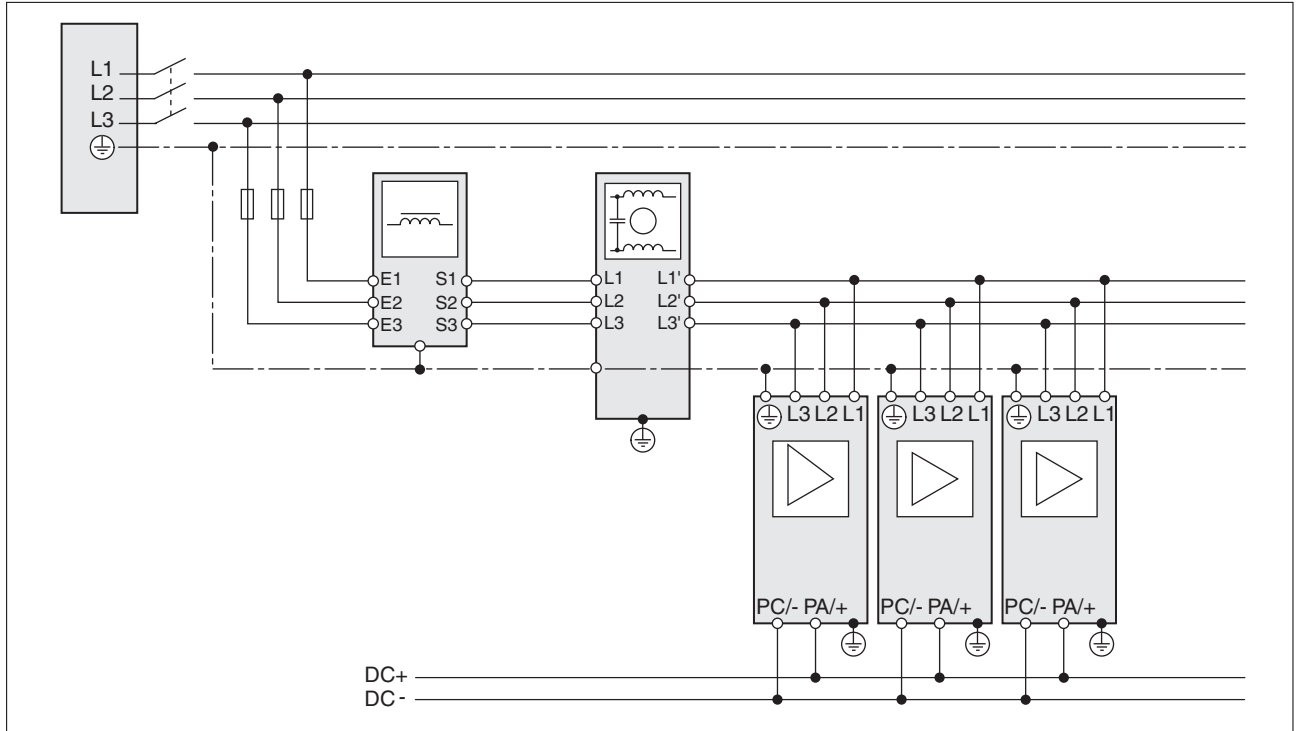

Figure 13: Wiring of drives with common mains fuse, mains reactor and mains filter, example shows three-phase drives.

4 Installation

An engineering phase is mandatory prior to mechanical and electrical installation. See chapter "3 EngineeringInstallation", page 21, for basic information.

Incorrect use of the DC bus may permanently damage the drives either immediately or over time.

⚠ WARNING

DESTRUCTION OF SYSTEM COMPONENTS AND LOSS OF CONTROL

Verify that all requirements for using the DC bus are met.

Failure to follow these instructions can result in death, serious injury, or equipment damage.

⚠ WARNING

DESTRUCTION OF SYSTEM COMPONENTS

- Connect only drives with identical nominal voltages.
- Connect single-phase drives only to single-phase drives. Connect single-phase drives to the same phase.
- Connect three-phase drives only to three-phase drives.

Failure to follow these instructions can result in death, serious injury, or equipment damage.

NOTICE

DESTRUCTION DUE TO INCORRECT OPERATION

Verify that the power stage supplies of the drives connected via a common DC bus are switched on simultaneously.

Failure to follow these instructions can result in equipment damage.

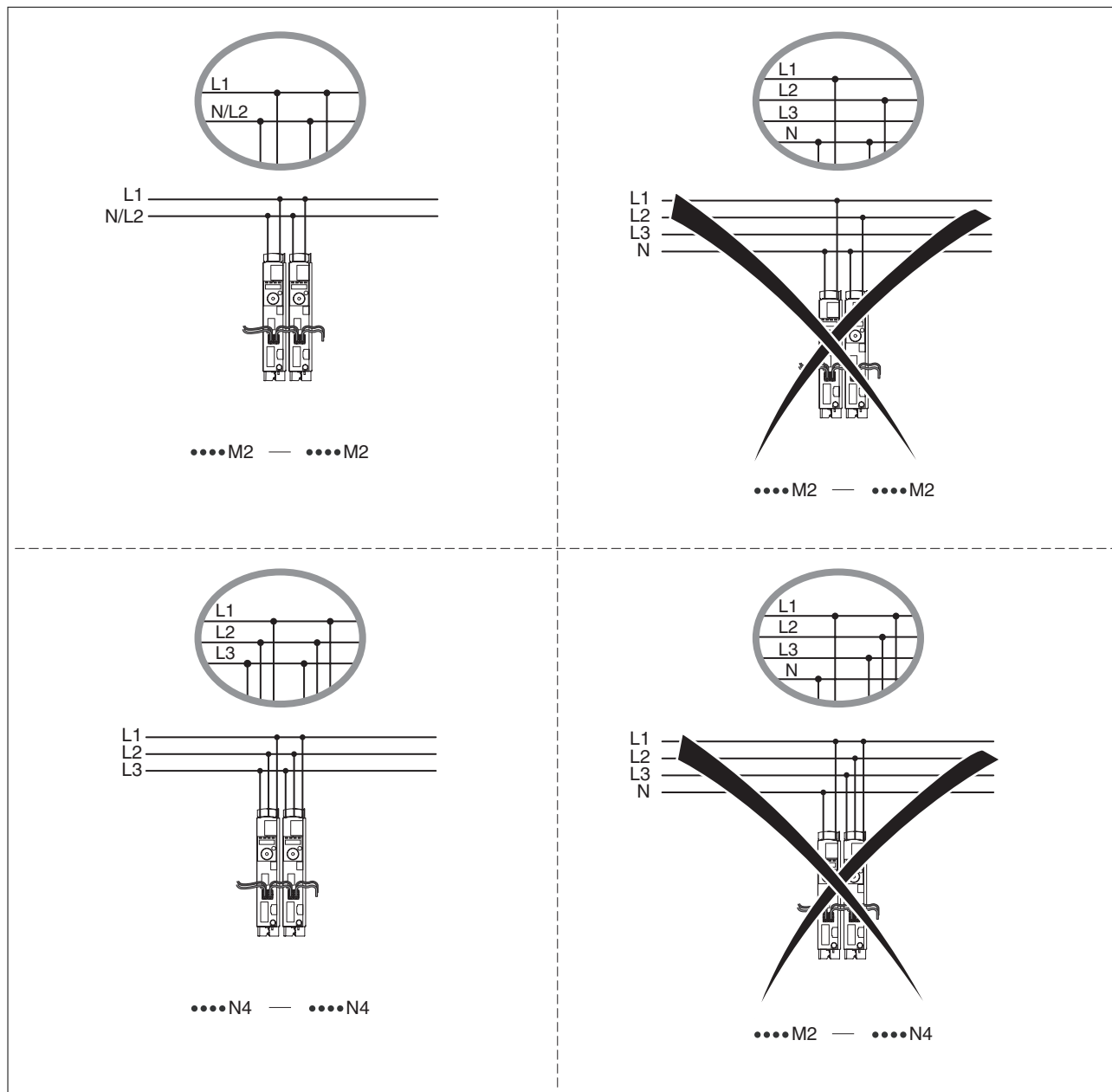

Figure 14: Specifications for drives with mains supply

4.1 Assembling cables

Pre-assembled cables are available for common DC bus. If the pre-assembled cables do not have the required length, use cables and crimp contacts, see chapter "6.1 DC bus accessories", page 55.

Properties of the DC bus cable

Note the DC bus cable properties, see chapter "2.4 Cables for the DC bus", page 20.

Assembling DC bus cables

The following instructions apply to drives with plug connections for the DC bus.

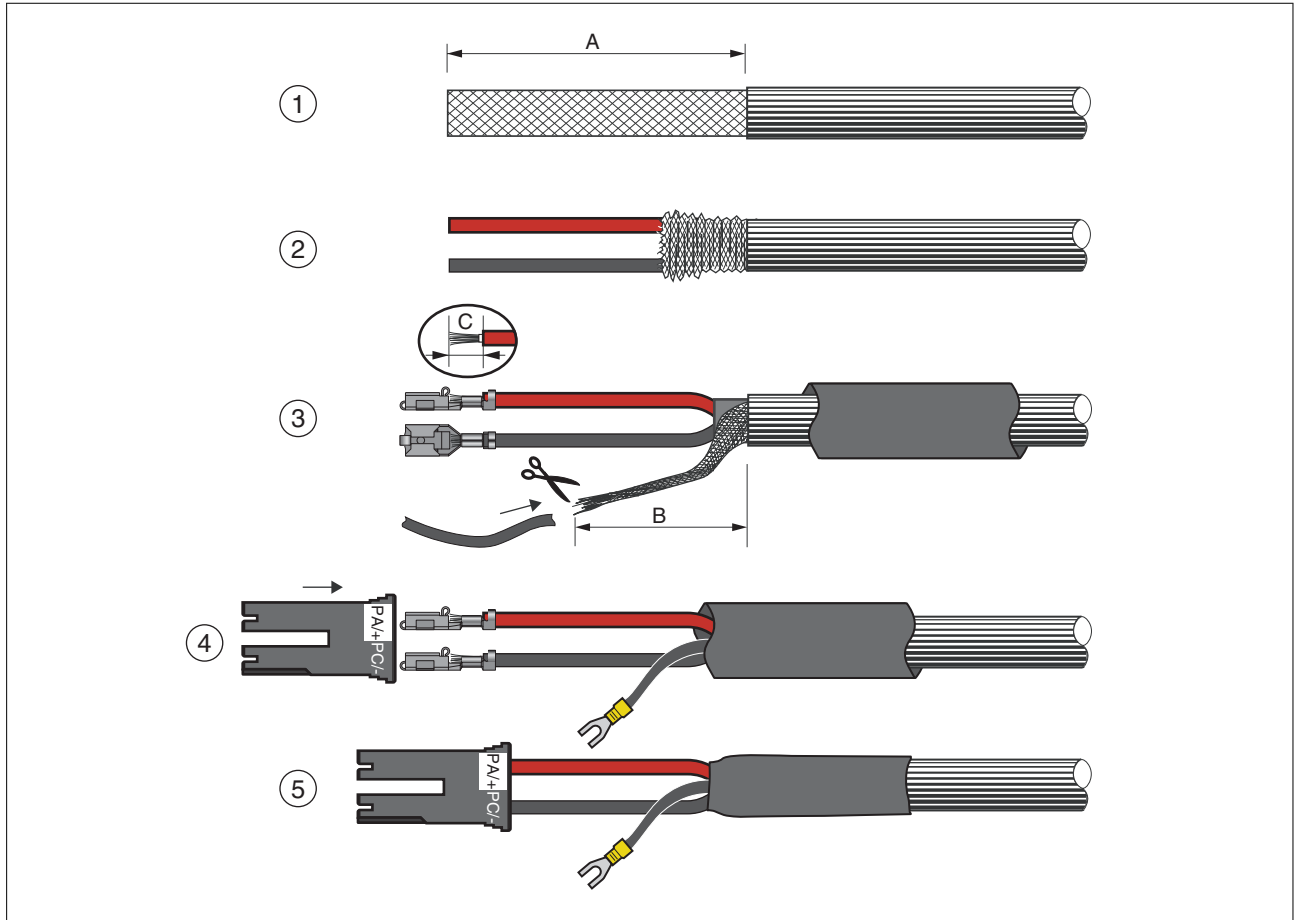

	Part	Length in mm (inches)
A	Cable jacket	130 (5.2)
B	Length of shield connection	60 (2.5)
C	Stripping length	6 (0.25)
	Diameter ring-type cable lug / fork-type cable lug	For M5 screw

- ▶ (1) Strip the cable jacket, length A.
- ▶ (2) Slide back the shield braiding. Open the shield braiding and twist it to form a shield connection wire.
- ▶ (3) Shorten the twisted shield connection wire to length B and insulate the shield braiding with heat shrink tube. Crimp the crimp contacts to the two stripped conductors. The stripping length is C. See chapter "6.1 DC bus accessories", page 55 for information on the crimping tool.
- ▶ (4) Crimp a fork-type cable lug to the shield connection wire. Push the crimp contacts into the connector housing. Polarity: the red wire is PA/+, the black wire is PC/-.
- ▶ (5) Secure the shield with heat shrink tube.

The following instructions apply to drives with screw terminals for the DC bus.

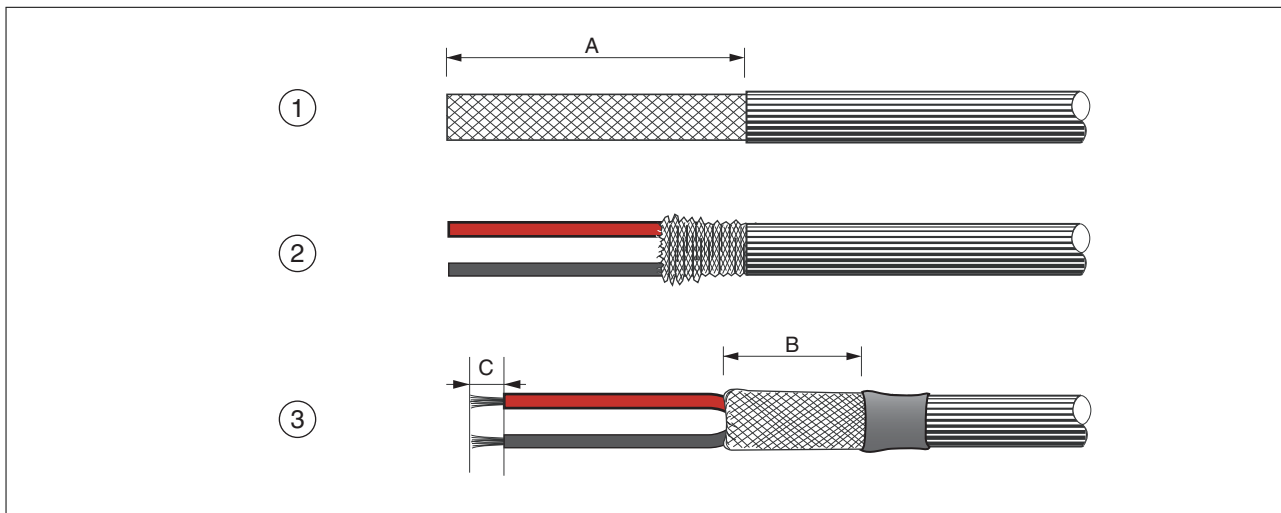

LXM32•...		D85, C10
A	mm (in)	220 (8.66)
B	mm (in)	50 (1.97)
C	mm (in)	18 (0.71)

- (1) Strip the cable jacket, length A.
- (2) Slide the shield braiding back over the cable jacket.
- (3) Secure the shield braiding with a heat shrink tube. The shield must have at least length D. Verify that a large surface area of the shield braiding is connected to the EMC shield clamp.

4.2 Wiring the DC bus

NOTICE

EQUIPMENT DAMAGE CAUSED BY INCORRECT POLARITY

Verify correct polarity during installation.

Failure to follow these instructions can result in equipment damage.

The DC bus is connected by means of a plug and socket connection or screw terminals.

Cable specifications See chapter "2.4 Cables for the DC bus", page 20 for the cable specifications. Pre-assembled cables and connector kits can be found in chapter "6 Accessories and spare parts", page 55.

4.2.1 Drives with connectors

Connector coding The connectors are coded. If you do not use pre-assembled cables, verify that the crimp contacts properly snap into the connector. Verify that PA/+ is connected to PA/+ and PC/- is connected to PC/-. Incorrect wiring will destroy the devices.

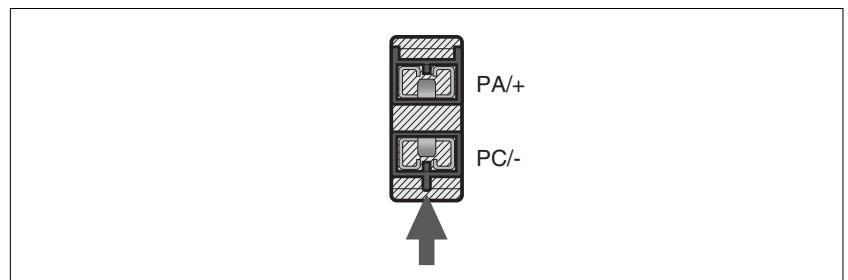

Figure 15: Connector coding

Connector lock The connector has a snap lock mechanism. Pull the connector housing to unlock the connector.

Both wires in the connector housing must be able to move independently for unlocking.



If you want to remove the DC bus connection cable, you must open the connector lock by pulling at the housing. The connection cable is easier to remove if you remove the motor connector first.

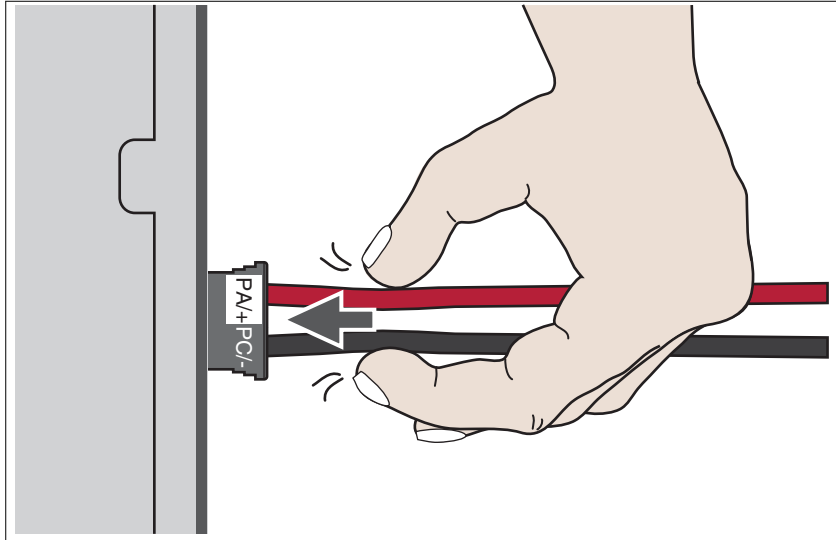

Figure 16: Unlocking the DC bus connector, step 1: Push cables towards connector.

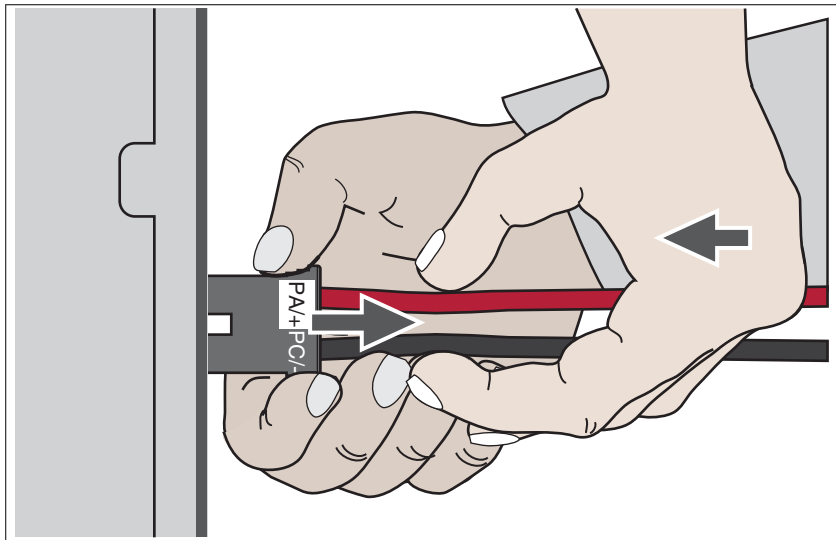

Figure 17: Unlocking the DC bus connector, step 2: Push cables towards connector, at the same time remove the connector with the other hand.

If the two wires cannot move freely, the DC bus connector will not unlock.

- ▶ Push the two wires towards the connector (see Figure 16).
- ▶ While pushing the wires towards the connector, pull the connector at the connector housing with the other hand. The connector is unlocked and you can remove the DC bus connection cable (see). The connector is unlocked and you can remove the DC bus connection cable (see Figure 17).

4.2.2 Drives with terminals

This chapter describes LXM32 drives with screw terminals.

Properties of the connection terminals CN9

LXM32•...		D85, C10
Connection cross section	mm ² (AWG)	6 ... 25 (10 ... 4)
Tightening torque for terminal screws	Nm (lb.in)	3.8 (33.6)
Stripping length	mm (in)	18 (0.71)

The terminals are approved for fine wire conductors and rigid conductors. Observe the maximum permissible connection cross section. Take into account the fact that wire ferrules increase the conductor cross section.

Wiring diagram

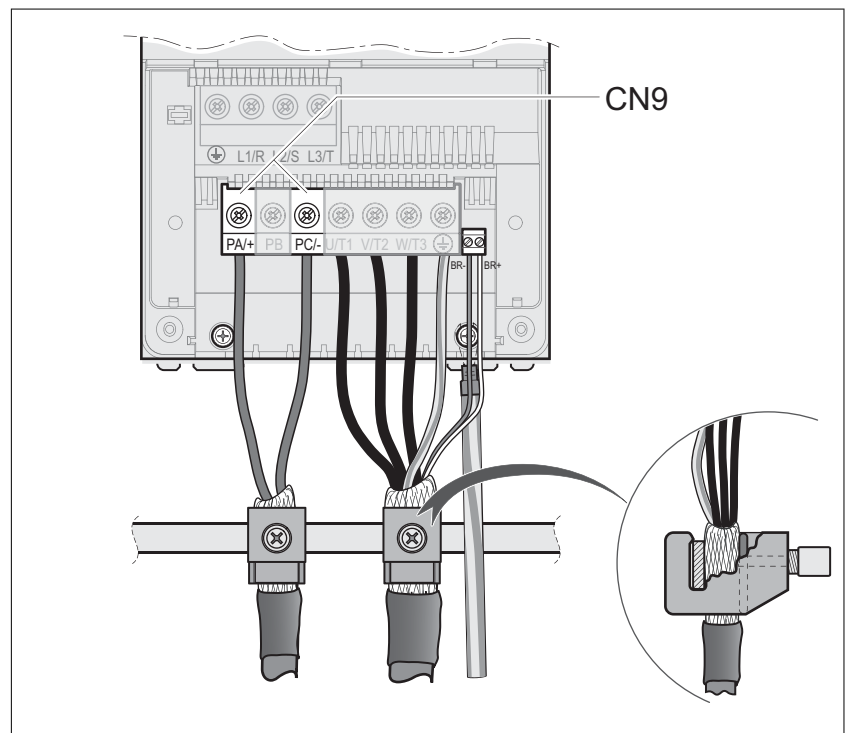

Figure 18: Wiring diagram DC bus

Connecting the DC bus

- ▶ Switch off all supply voltages. Observe the safety instructions concerning electrical installation.
- ▶ Connect the DC bus to the device. Connect PA/+ to PA/+ (red) and PC/- to PC/- (black). Note the tightening torque specified for the terminal screws.
- ▶ Connect the cable shield with a shield clamp to an EMC rail (large surface area contact).
Verify that the individual wires are in the individual guides.
- ▶ Mount the cable guide.

4.2.3 Connecting the DC bus

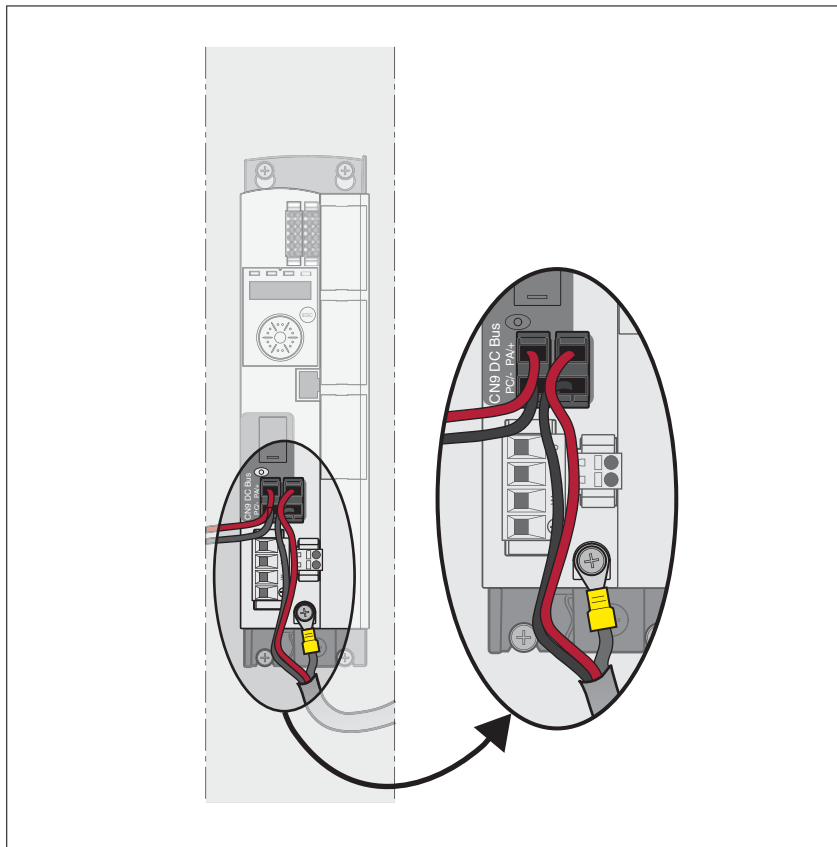

Figure 19: DC bus connection, example with connector

- ▶ Verify that the requirements concerning the DC bus are met, see chapter "3 EngineeringInstallation".
- ▶ Use pre-assembled cables whenever possible (page 55) to reduce the risk of wiring errors.
- ▶ Only connect the devices with the specified accessories. The connectors are coded. Connect PA/+ to PA/+ (red) and PC/- to PC/- (black).

4.3 Verifying installation

- ▶ Verify that the wiring complies with the specifications as per chapter "3 EngineeringInstallation".
- ▶ Verify that the fuses used do not exceed the maximum permissible fuse rating.
- ▶ Verify that PA/+ is only connected to PA/+ and that PC/- is only connected to PC/-.
- ▶ Verify that the shield is connected to a large surface area if you use shielded DC bus cables.
- ▶ Verify that the connector locks are properly snapped in.

5 Commissioning

For commissioning, follow the commissioning instructions for the individual devices in the manual of the respective product.

Incorrect use of the DC bus may permanently damage the drives either immediately or over time.

⚠ WARNING

DESTRUCTION OF SYSTEM COMPONENTS AND LOSS OF CONTROL

Verify that all requirements for using the DC bus are met.

Failure to follow these instructions can result in death, serious injury, or equipment damage.

NOTICE

DESTRUCTION DUE TO INCORRECT OPERATION

Verify that the drives connected via a common DC bus are switched on simultaneously.

Failure to follow these instructions can result in equipment damage.

5.1 Commissioning procedure

5.1.1 DC bus connection LXM32 to LXM32

Commissioning steps:

- ▶ Verify proper installation of the drives and the connections for the common DC bus, see chapter "4.3 Verifying installation", page 49.
- ▶ Switch on the controller supply for all devices.
- ▶ Set the parameters for the braking resistors, see chapter "5.2 LXM32: Setting the braking resistor parameters".
- ▶ Commission the drives, see the descriptions in the manuals for the individual products.

5.1.2 Supply via the DC bus

Commissioning steps:

- ▶ Verify proper installation of the drives and the connections for the common DC bus, see chapter "4.3 Verifying installation", page 49.
- ▶ Switch on the controller supply for all devices.
- ▶ LXM32: Set the parameter `MON_MainsVolt` to "DC-Bus Only" for LXM32.

Parameters	Value
<code>MON_MainsVolt</code>	DC-Bus Only

- ▶ LXM32: Set the parameters for the braking resistors of LXM32 drives, see chapter "5.2 LXM32: Setting the braking resistor parameters".
- ▶ Commission the drives, see the descriptions in the manuals for the individual products.

5.2 LXM32: Setting the braking resistor parameters

An insufficiently rated braking resistor can cause overvoltage on the DC bus. Overvoltage on the DC bus causes the power stage to be disabled. The motor is no longer actively decelerated.

⚠ WARNING
MOTOR WITHOUT BRAKING EFFECT
<ul style="list-style-type: none">• Verify that the braking resistor has a sufficient rating.• Verify that the parameter settings for the braking resistor are correct.• Verify that the I²t value for temperature monitoring does not exceed 100% by performing a test run under maximum load conditions.• Verify that the calculations and the test run take into account the fact that the DC bus capacitors can absorb less braking energy at higher mains voltages.
Failure to follow these instructions can result in death, serious injury, or equipment damage.

The temperature of the braking resistor may exceed 250 °C (482 °F) during operation.

⚠ WARNING
HOT SURFACES
<ul style="list-style-type: none">• Ensure that any contact with a hot braking resistor is avoided.• Do not allow flammable or heat-sensitive parts in the immediate vicinity of the braking resistor.• Verify that the heat dissipation is sufficient by performing a test run under maximum load conditions.
Failure to follow these instructions can result in death, serious injury, or equipment damage.

- ▶ Check the parameter `RESint_ext`. If you have connected an external braking resistor, you must set the parameter to "external".
- ▶ If you have connected an external braking resistor, (value of the parameter `RESint_ext` is set to "external"), you must assign the appropriate values to the parameters `RESext_P`, `RESext_R` and `RESext_ton`. Verify that the selected external braking resistor is really connected.
- ▶ Test the function of the braking resistor under realistic, worst case conditions.

If the regenerated power becomes greater than the power that can be absorbed by the braking resistor, an error message is generated and the power stage is disabled.

See the product manual for a description of the parameters.

6 Accessories and spare parts

6.1 DC bus accessories

Description	Order no.
DC bus connection cable, 2 * 6 mm ² (2 * AWG 10), pre-assembled, 0.1 m, 5 pieces	VW3M7101R01
DC bus connection cable, 2 * 6 mm ² (2 * AWG 10), Twisted Pair, shielded, 15 m	VW3M7102R150
DC bus connector kit, connector housing and crimp contacts for 3 ... 6 mm ² (AWG 12 ... 10), 10 pieces	VW3M2207

A crimping tool is required for the crimp contacts of the connector kit.

Manufacturer:

Tyco Electronics, Heavy Head Hand Tool, Tool Pt. No 180250

6.2 DC fuses

The following DC fuses are offered by SIBA.

<http://www.siba-fuses.com>

Description	SIBA order no.
DC fuse, DC 700V 10A	5020106.10
DC fuse, DC 700V 16A	5020106.16
DC fuse, DC 700V 25A	5020106.25
DC fuse, DC 700V 32A	5020106.32
DC fuse, DC 700V 40A	5020106.40
DC fuse, DC 700V 50A	5020106.50
DC fuse, DC 700V 63A	5020106.63

6.3 External braking resistors

Description	Order no.
Braking resistor IP65; 10 Ω; maximum continuous power 400 W; 0.75 m connection cable (2.1 mm ²), UL	VW3A7601R07
Braking resistor IP65; 10 Ω; maximum continuous power 400 W; 2 m connection cable (2.1 mm ²), UL	VW3A7601R20
Braking resistor IP65; 10 Ω; maximum continuous power 400 W; 3 m connection cable (2.1 mm ²), UL	VW3A7601R30
Braking resistor IP65; 27 Ω; maximum continuous power 100 W; 0.75 m connection cable (2.1 mm ²), UL	VW3A7602R07
Braking resistor IP65; 27 Ω; maximum continuous power 100 W; 2 m connection cable (2.1 mm ²), UL	VW3A7602R20
Braking resistor IP65; 27 Ω; maximum continuous power 100 W; 3 m connection cable (2.1 mm ²), UL	VW3A7602R30
Braking resistor IP65; 27 Ω; maximum continuous power 200 W; 0.75 m connection cable (2.1 mm ²), UL	VW3A7603R07
Braking resistor IP65; 27 Ω; maximum continuous power 200 W; 2 m connection cable (2.1 mm ²), UL	VW3A7603R20
Braking resistor IP65; 27 Ω; maximum continuous power 200 W; 3 m connection cable (2.1 mm ²), UL	VW3A7603R30
Braking resistor IP65; 27 Ω; maximum continuous power 400 W; 0.75 m connection cable (2.1 mm ²), UL	VW3A7604R07
Braking resistor IP65; 27 Ω; maximum continuous power 400 W; 2 m connection cable (2.1 mm ²), UL	VW3A7604R20
Braking resistor IP65; 27 Ω; maximum continuous power 400 W; 3 m connection cable (2.1 mm ²), UL	VW3A7604R30
Braking resistor IP65; 72 Ω; maximum continuous power 100 W; 0.75 m connection cable (2.1 mm ²), UL	VW3A7605R07
Braking resistor IP65; 72 Ω; maximum continuous power 100 W; 2 m connection cable (2.1 mm ²), UL	VW3A7605R20
Braking resistor IP65; 72 Ω; maximum continuous power 100 W; 3 m connection cable (2.1 mm ²), UL	VW3A7605R30
Braking resistor IP65; 72 Ω; maximum continuous power 200 W; 0.75 m connection cable (2.1 mm ²), UL	VW3A7606R07
Braking resistor IP65; 72 Ω; maximum continuous power 200 W; 2 m connection cable (2.1 mm ²), UL	VW3A7606R20
Braking resistor IP65; 72 Ω; maximum continuous power 200 W; 3 m connection cable (2.1 mm ²), UL	VW3A7606R30
Braking resistor IP65; 72 Ω; maximum continuous power 400 W; 0.75 m connection cable	VW3A7607R07
Braking resistor IP65; 72 Ω; maximum continuous power 400 W; 2 m connection cable	VW3A7607R20
Braking resistor IP65; 72 Ω; maximum continuous power 400 W; 3 m connection cable	VW3A7607R30
Braking resistor IP65; 100 Ω; maximum continuous power 100 W; 0.75 m connection cable	VW3A7608R07
Braking resistor IP65; 100 Ω; maximum continuous power 100 W; 2 m connection cable	VW3A7608R20
Braking resistor IP65; 100 Ω; maximum continuous power 100 W; 3 m connection cable	VW3A7608R30
Braking resistor IP20; 15 Ω; maximum continuous power 1000 W; M6 terminals, UL	VW3A7704
Braking resistor IP20; 10 Ω; maximum continuous power 1000 W; M6 terminals, UL	VW3A7705

Glossary



Units and conversion tables

The value in the specified unit (left column) is calculated for the desired unit (top row) with the formula (in the field).

Example: conversion of 5 meters (m) to yards (yd)
 $5 \text{ m} / 0.9144 = 5.468 \text{ yd}$

Length

	in	ft	yd	m	cm	mm
in	-	/ 12	/ 36	* 0.0254	* 2.54	* 25.4
ft	* 12	-	/ 3	* 0.30479	* 30.479	* 304.79
yd	* 36	* 3	-	* 0.9144	* 91.44	* 914.4
m	/ 0.0254	/ 0.30479	/ 0.9144	-	* 100	* 1000
cm	/ 2.54	/ 30.479	/ 91.44	/ 100	-	* 10
mm	/ 25.4	/ 304.79	/ 914.4	/ 1000	/ 10	-

Mass

	lb	oz	slug	kg	g
lb	-	* 16	* 0.03108095	* 0.4535924	* 453.5924
oz	/ 16	-	* $1.942559 \cdot 10^{-3}$	* 0.02834952	* 28.34952
slug	/ 0.03108095	/ $1.942559 \cdot 10^{-3}$	-	* 14.5939	* 14593.9
kg	/ 0.45359237	/ 0.02834952	/ 14.5939	-	* 1000
g	/ 453.59237	/ 28.34952	/ 14593.9	/ 1000	-

Force

	lb	oz	p	N
lb	-	* 16	* 453.55358	* 4.448222
oz	/ 16	-	* 28.349524	* 0.27801
p	/ 453.55358	/ 28.349524	-	* $9.807 \cdot 10^{-3}$
N	/ 4.448222	/ 0.27801	/ $9.807 \cdot 10^{-3}$	-

Power

	HP	W
HP	-	* 746
W	/ 746	-

Rotation

	min ⁻¹ (RPM)	rad/s	deg./s
min ⁻¹ (RPM)	-	* π / 30	* 6
rad/s	* 30 / π	-	* 57.295
deg./s	/ 6	/ 57.295	-

Torque

	lb-in	lb-ft	oz-in	Nm	kp-m	kp-cm	dyne-cm
lb-in	-	/ 12	* 16	* 0.112985	* 0.011521	* 1.1521	* 1.129*10 ⁶
lb-ft	* 12	-	* 192	* 1.355822	* 0.138255	* 13.8255	* 13.558*10 ⁶
oz-in	/ 16	/ 192	-	* 7.0616*10 ⁻³	* 720.07*10 ⁻⁶	* 72.007*10 ⁻³	* 70615.5
Nm	/ 0.112985	/ 1.355822	/ 7.0616*10 ⁻³	-	* 0.101972	* 10.1972	* 10*10 ⁶
kp-m	/ 0.011521	/ 0.138255	/ 720.07*10 ⁻⁶	/ 0.101972	-	* 100	* 98.066*10 ⁶
kp-cm	/ 1.1521	/ 13.8255	/ 72.007*10 ⁻³	/ 10.1972	/ 100	-	* 0.9806*10 ⁶
dyne-cm	/ 1.129*10 ⁶	/ 13.558*10 ⁶	/ 70615.5	/ 10*10 ⁶	/ 98.066*10 ⁶	/ 0.9806*10 ⁶	-

Moment of inertia

	lb-in ²	lb-ft ²	kg-m ²	kg-cm ²	kp-cm-s ²	oz-in ²
lb-in ²	-	/ 144	/ 3417.16	/ 0.341716	/ 335.109	* 16
lb-ft ²	* 144	-	* 0.04214	* 421.4	* 0.429711	* 2304
kg-m ²	* 3417.16	/ 0.04214	-	* 10*10 ³	* 10.1972	* 54674
kg-cm ²	* 0.341716	/ 421.4	/ 10*10 ³	-	/ 980.665	* 5.46
kp-cm-s ²	* 335.109	/ 0.429711	/ 10.1972	* 980.665	-	* 5361.74
oz-in ²	/ 16	/ 2304	/ 54674	/ 5.46	/ 5361.74	-

Temperature

	°F	°C	K
°F	-	(°F - 32) * 5/9	(°F - 32) * 5/9 + 273.15
°C	°C * 9/5 + 32	-	°C + 273.15
K	(K - 273.15) * 9/5 + 32	K - 273.15	-

Conductor cross section

AWG	1	2	3	4	5	6	7	8	9	10	11	12	13
mm ²	42.4	33.6	26.7	21.2	16.8	13.3	10.5	8.4	6.6	5.3	4.2	3.3	2.6

AWG	14	15	16	17	18	19	20	21	22	23	24	25	26
mm ²	2.1	1.7	1.3	1.0	0.82	0.65	0.52	0.41	0.33	0.26	0.20	0.16	0.13

Terms and Abbreviations

See chapter "Standards and terminology" for information on the pertinent standards on which many terms are based. Some terms and abbreviations may have specific meanings with regard to the standards.

<i>AC</i>	Alternating current
<i>DC</i>	Direct current
<i>DC bus</i>	Circuit that supplies the power stage with energy (direct voltage).
<i>Drive system</i>	System consisting of controller, drive and motor.
<i>EMC</i>	Electromagnetic compatibility
<i>Error</i>	Discrepancy between a detected (computed, measured or signaled) value or condition and the specified or theoretically correct value or condition.
<i>Error class</i>	Classification of errors into groups. The different error classes allow for specific responses to errors, for example by severity.
<i>Factory setting</i>	Factory settings when the product is shipped
<i>Fault</i>	Fault is an operating state. If the monitoring functions detect an error, a transition to this operating state is triggered, depending on the error class. A "Fault Reset" is required to exit this operating state after the cause of the detected error has been removed. Further information can be found in the pertinent standards such as IEC 61800-7, ODVA Common Industrial Protocol (CIP).
<i>Fault Reset</i>	A function used to restore the drive to an operational state after a detected error is cleared by removing the cause of the error so that the error is no longer active.
<i>Parameter</i>	Device data and values that can be read and set (to a certain extent) by the user.
<i>PELV</i>	Protective Extra Low Voltage, low voltage with isolation. For more information: IEC 60364-4-41
<i>Persistent</i>	Indicates whether the value of the parameter remains in the memory after the device is switched off.
<i>Power stage</i>	The power stage controls the motor. The power stage generates current for controlling the motor on the basis of the motion signals from the controller.
<i>Quick Stop</i>	The Quick Stop function can be used for fast deceleration of a movement as a response to a detected error or via a command.
<i>Warning</i>	If the term is used outside the context of safety instructions, a warning alerts to a potential problem that was detected by a monitoring function. A warning does not cause a transition of the operating state.

Table of figures



1)	Movement cycle: Profile for energy assessment	23
2)	Single mains fuse for single-phase drives	25
3)	Multiple mains fuses for single-phase drives	26
4)	Single mains fuse for three-phase drives	27
5)	Multiple mains fuses for three-phase drives	28
6)	Supply via the DC bus by a drive	30
7)	Supply via the DC bus by a DC power supply unit	30
8)	Supply via the DC bus by a drive	31
9)	Supply via the DC bus by a DC power supply unit	31
10)	Wiring of drives with common AC fuse and a mains reactor, example shows three-phase drives.	36
11)	Wiring of drives with individual AC fuses and mains reactors, example shows single-phase drives. ..	37
12)	Wiring of an external mains filter, example shows three-phase drives.	38
13)	Wiring of drives with common mains fuse, mains reactor and mains filter, example shows three-phase drives.	39
14)	Specifications for drives with mains supply	42
15)	Connector coding	45
16)	Unlocking the DC bus connector, step 1: Push cables towards connector.	46
17)	Unlocking the DC bus connector, step 2: Push cables towards connector, at the same time remove the connector with the other hand.	46
18)	Wiring diagram DC bus	47
19)	DC bus connection, example with connector	48

Index



A	Abbreviations 59 Accessories External braking resistor, data 19 Accessories and spare parts 55	E	EMC 24 Energy balance 22 External braking resistors 19
B	Braking resistor 17 External 19 Monitoring 33 Rating 32 Selection 33 Braking resistors common DC bus 32	G	Glossary 57
C	Commissioning 51 Parameters for braking resistor 54 steps 52 Common DC bus Braking resistors 32 Common DC-Bus Installation 45 Connector Coding 45 Lock 45	H	Hazard categories 5
D	DC bus Braking resistors 32	I	Installation of common DC bus 45 Intended use 6 Introduction 13
		M	Manuals Source 11 Monitoring Braking resistor 33
		P	Parameters for braking resistor 54
		Q	Qualification of personnel 6
		R	Rating Energy balance 22

	Rating information		Terms	59
	Braking resistor	34	U	
	Rating of braking resistor	32		
S			Units and conversion tables	57
	Safety Information	5	W	
	Source		Wiring	45
	Manuals	11	Wiring diagram	
T			External braking resistor	47
	Technical data	15		