

California

MOSFET POWER AMPLIFIERS

Installation Instructions / Owner's Manual

100SX • 200SX • 400SX • 600SX
800SX • 1200SX • 440SX • 640SX



PRFILE®

INTRODUCTION

Congratulations on your purchase of a California state-of-the-art power amplifier. Your selection of a California car audio product indicates a true appreciation of fine musical reproduction. Whether adding to an existing system or including your California amplifier in a new system, you are certain to notice immediate performance benefits.

KEEP YOUR SALES RECEIPT

Take this time to attach your sales receipt to the manual and put in a safe place. In case of any unforeseen reason this product may need warranty service, your receipt will be necessary to establish purchase date.

RECOMMENDATION

A power amplifier's performance is only as good as its installation. Proper installation will maximize the system's overall performance. It is recommended that you have our product installed by an authorized Profile retailer. However, if you decide to install it yourself, please carefully read through this manual and take your time to do a quality installation.

IMPORTANT! Before making any connections, disconnect the car's battery until the installation is completed to avoid possible damage to the electrical system.

WARNING!

Exposure to high power sound system can cause hearing loss or damage. Listening to your system at loud levels while driving, will impair your ability to hear traffic sounds and emergency vehicles. Use common sense when listening to your system.

Serial # _____

Model # _____



SAFETY PRECAUTIONS

Fuse amplifier's power wire at the battery.

Be sure to fuse the power wire within 12" of the car's battery. This will protect the car's battery in case of a short circuit between the power amplifier and battery. **THIS IS A MUST**, the amplifier's built-in fuse will only protect the power amplifier not the car's battery!

Use high grade wire connectors.

To ensure maximum power transfer and secure safe connections, it is recommended to use high grade barrier spades (for connection at amplifier) and terminal rings (for connection at battery).

Do not run any wires underneath vehicle.

Exposed wires have a chance of being cut or damaged. It is best to run all wires through the vehicle under the carpet and/or side panels. This lends to a cleaner installation and less risk of damage.

Use caution when mounting amplifier.

Remember there are many electrical wires, gas lines, vacuum lines, brake lines as well as a gas tank in the automobile. Make sure you know where they are when mounting the amplifier to avoid puncturing lines, shorting wires or drilling holes in the gas tank.

Run signal wires away from electrical wires.

To avoid possibility of induced noise from the car's electrical system (i.e. popping noises or engine noise), run wires away from the car's electrical wiring.

Make all ground wires as short as possible and at the same point.

In order to reduce the chance of ground loops (i.e. engine noise), make the grounding wire as short as possible to reduce the wire's resistance. Also, when using multiple components, make sure all units are grounded at the same point.

Avoid sharp edges when running the wires.

To avoid the possibility of power, signal or speaker shorts, be careful not to allow the amplifiers wires to come in contact with sharp edges. Use a grommet to protect the wire when running through the fire wall.

FEATURES AND BENEFITS

DC Offset Protection

This circuit protects the output of the amplifier against DC voltage. If for some reason DC voltage is detected at the output stage, the amplifier will shut down protecting the speakers from direct current.

Short Circuit Protection

The circuit protects the amplifier from damage due to a short found in the speakers or wiring. If one of the speakers or its wiring comes in contact with ground, the amplifier will shut down. To resume normal operation, correct the problem and turn the head unit off, then back on. The amplifier will reset and play again.

Thermal Protection

To protect the amplifier circuitry against damage caused by prolonged exposure to high temperatures, a thermal protection circuit is activated if the amplifier reaches excessively high operating temperature. Once the thermal circuit is activated, the amplifier will shut down to cool off. The Amplifier will automatically turn back on once it cools down to a safe operating temperature.

Protection Indicator

This red diagnostic L.E.D. indicates that the amplifier has gone in to protection. Once on, the amplifier will have no output. To resume normal operation, turn head unit off and back on again. If the amplifier immediately goes back into protection, check for high temperature, short circuits or low impedance.

Tri Mode Capable

If so desired the amplifier may be run in stereo and mono at the same time. For example, this feature would allow you to run a pair of mid and tweeters in stereo and a sub-woofer mono.

Built-in Crossover

The California amplifiers include a built-in variable high or low pass crossover. The crossover features a variable frequency selection (40Hz ~ 130Hz) for precise high or low pass filtering.



Bass Boost

For added low frequency performance the two channel amplifiers are equipped with 12dB bass boost.

Power Fusing

This protects the amplifier against short circuits and excessive current.

Remote Turn-on

Automatically turns amplifier on when connected to the head unit's remote output. The amplifier will turn on and off with the head unit to save current consumption. This control also operates the reset circuit for the amplifier's protection. It must be connected with the head unit in order to reset protection circuits.

Gold Plated Connections

For positive contact, maximum power and signal transfer with minimal resistance.

Adjustable Input Sensitivity

Allows you to fine-tune the level matching between your source and the power amplifier. The controls have been set at the factory to accept average output of most radios, however, fine tuning may be necessary to optimize signal to the amplifiers input stage.

High Level Input

Allowing for integration with "Factory Sound Systems" (Models 100SX, 200SX and 400SX).

Stable To 2 Ohm Stereo Mode

Stability to 2 ohm in stereo mode, 4 ohms bridged.

MOUNTING LOCATION

Before you start the installation, it will be necessary to find a mounting location for the amplifier. Find a location in which the amplifier will receive adequate ventilation in order to dissipate the heat it develops during operation. Two popular mounting locations are in the trunk or under the seat.

Select the location in which you wish to mount the amplifier. **Use caution when mounting amplifier, there are many wires, gas lines, vacuum lines, brake lines as well as a gas tank in the automobile. Make sure you know where they are when mounting the amplifier to avoid puncturing lines, shorting wires or drilling holes in the gas tank.** Once you are ready, use a pencil to mark the mounting holes in the bottom panel. After you have marked the locations of the holes move amplifier out of the way and drill small starter holes to make the tapping screws easier to install. Use provided screws to tighten down the amplifier.

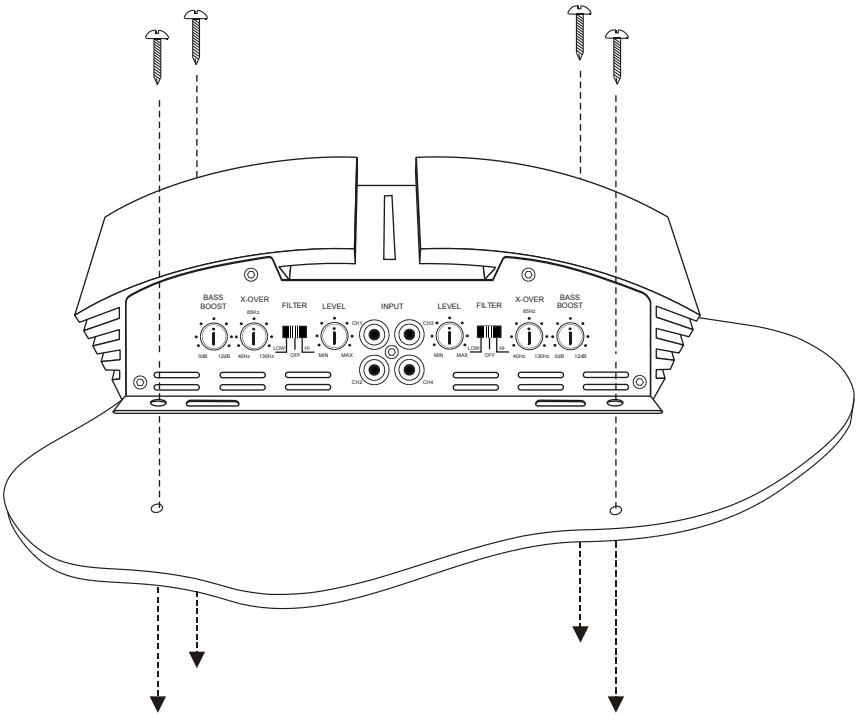

POWER CONNECTIONS

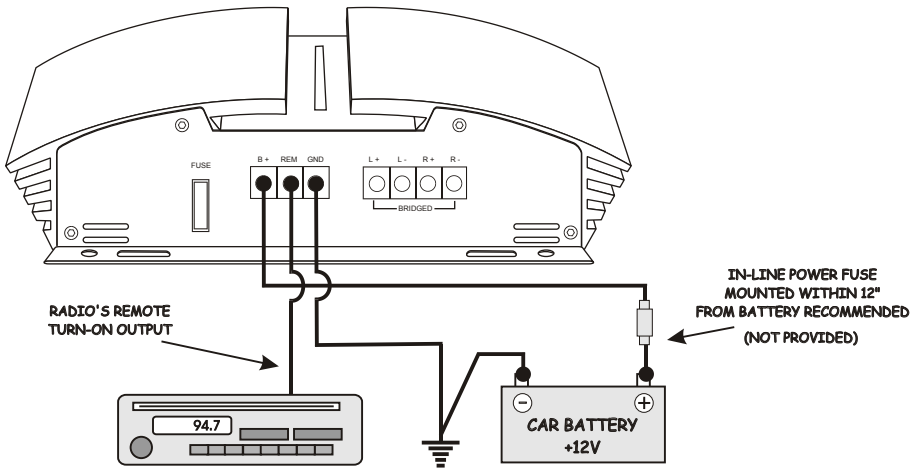

IMPORTANT! Before making any connections, disconnect the car's battery until the installation is completed to avoid possible damage to the electrical system.

Connect the amplifier to the car's battery.

At times, the amplifier will need to draw large levels of current that cannot be provided by any circuit in the car's fuse box. We recommended using an 8 to 10 gauge power wire for your connections depending on the amplifier and length of the wire. Strip one end of the wire to connect to the terminal on the amplifier marked +12V. Loosen screw terminal and connect bare wire and tighten. Use caution to make sure no stray wire stands come in contact with surrounding terminals causing short circuits. Run the wire directly to the positive terminal of the car's battery. Make sure to use an in-line fuse within 12" of the car's battery to protect the electrical system and amplifier against short circuits and/or power surges.

Connect the ground terminal of the amplifier to the car's chassis.

For the ground connection, use an 8-10 gauge wire (black) to connect to the terminal marked GND and then connect it to the car's chassis. Try to keep the length of the cable as short as possible, preferably less than 6". Also make sure that the point on the car where the connection is to be made is free of paint and dirt.

Connect the remote terminal of the amplifier to a switchable +12V source.

This connection allows the amplifier to be turned on and off with the power control of the radio. If the radio has a REMOTE output terminal, connect it to the amplifier's terminal marked REMOTE (using a 16 gauge wire or heavier). Now when the radio is turned on, the amplifier will automatically turn on.

SIGNAL CONNECTIONS

Connect the output of the head unit (AM/FM cassette player, CD, or DAT) to the RCA input terminals of the amplifier.

To make these connections, we recommend high quality RCA cables, which are available at your local car audio retailer. Run signal wires away from electrical wires to avoid possibility of induced noise from the car's electrical system (i.e. popping noises or engine noise). Please note that when making these connections the signal inputs correspond with the speaker outputs. For example: If you connect the radio's front right RCA to "CH 1"then speaker output "CH1" will operate the front right speaker.

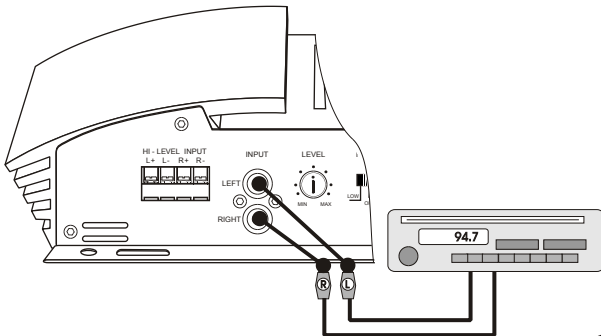

TWO CHANNEL SIGNAL CONNECTIONS

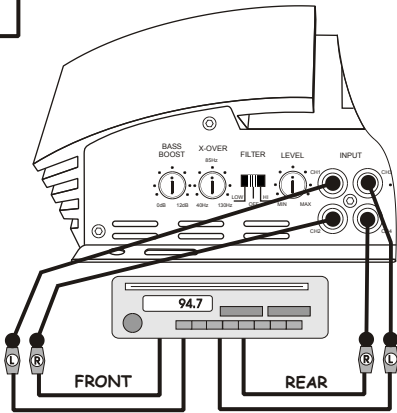

FOUR CHANNEL SIGNAL CONNECTIONS
(RADIO WITH FRONT AND REAR OUTPUTS)

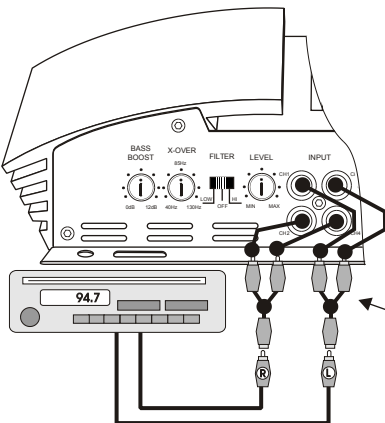

Connect 2 sets of RCA "Y" adaptors to split the two RCA's from the radio into 4 outputs
(Not Provided)

FOUR CHANNEL SIGNAL CONNECTIONS
(RADIO WITH ONLY ONE SET OF RCA'S)



HIGH LEVEL CONNECTIONS (OPTIONAL)

If a low level RCA signal source is not available, you may still wire the models 100SX, 200SX, and 400SX with high-level or speaker level outputs from your head unit. However, only speaker leads from a "floating ground" system may be used (see diagram below). Use the strip connector located on the end of the amplifier to make this connection. The strip connector should be connected with the front or rear, 2 channels of your head unit.

Note: The speaker leads from a "common ground" head unit systems should not be connected to the hi-level input terminals of the following connections.

CAUTION! Before making any connections determine the type of radio to avoid possible damage to amplifier and/or radio.

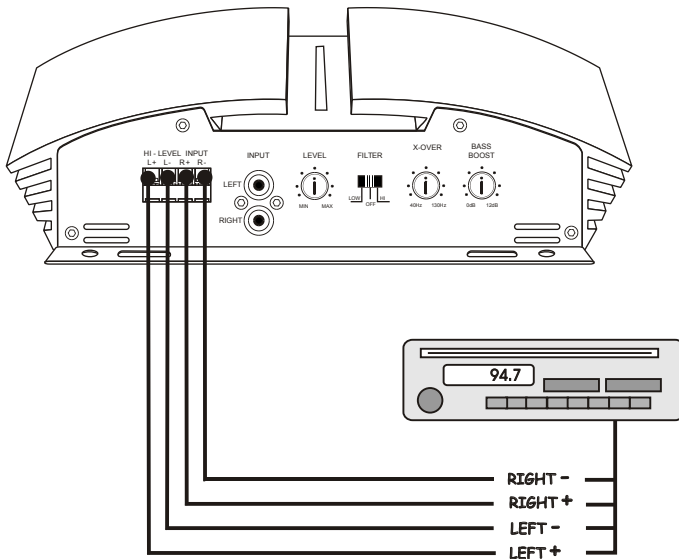

**TWO CHANNEL CONNECTIONS:
FLOATING GROUND RADIO (MOST COMMON TYPE)**

SPEAKER CONNECTIONS

Make the speaker connections using speaker wire that is at least 16 gauge or heavier.

As with any audio component, proper phasing of the amplifier and speakers is essential for strong bass response. When connecting, make sure that positive (+) from the amplifier is connected to the positive (+) of the speaker, and the same for negative (-).

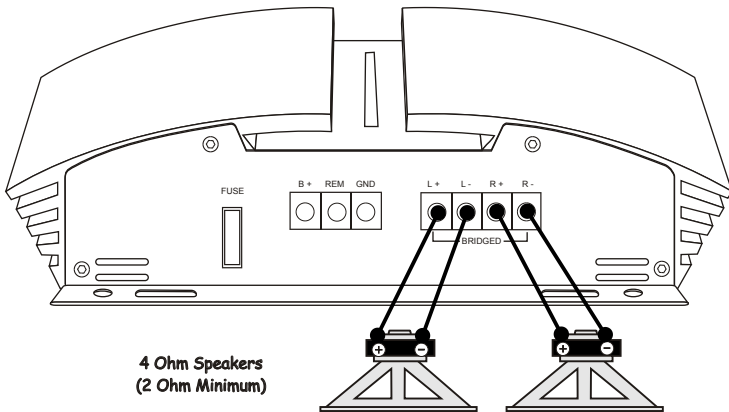

TWO CHANNEL SPEAKER CONNECTIONS

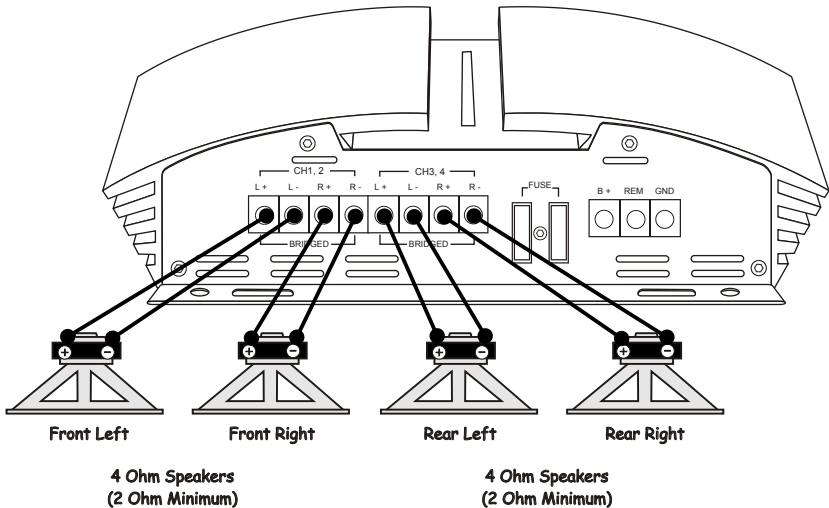

FOUR CHANNEL SPEAKER CONNECTIONS



SPEAKER CONNECTIONS (BRIDGED)

The California amplifiers are capable of being bridged in a mono configuration. This feature allows you the flexibility of using the amplifier to drive a ****** subwoofer or a center channel. In this configuration the amplifier sums the right and left channel to deliver one channel (mono) output.

Please note: in order for the amplifier to sum right and left signal information, both right and left RCA connections must be made.

****CAUTION!** In the bridged mode, the amplifier must see a 4 Ohm load or higher. Any lower than 4 Ohms will cause the amplifier to overheat and possibly cause permanent damage to the amplifier!

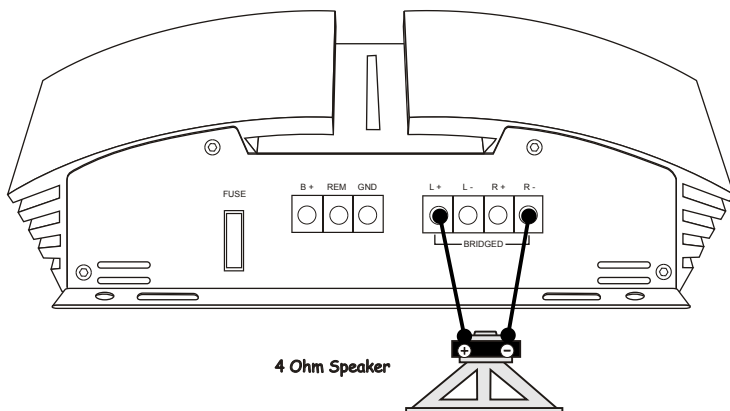

TWO CHANNEL BRIDGED SPEAKER CONNECTIONS

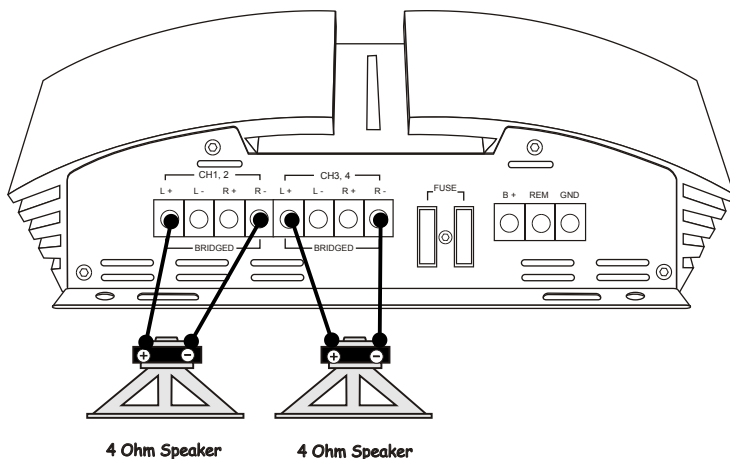

FOUR CHANNEL BRIDGED SPEAKER CONNECTIONS

SPEAKER CONNECTIONS (TRI-MODE)

The amplifier is capable of running in a Mono / Stereo mode. This feature gives the amplifier the ability to run stereo satellites (midbass & tweeter) simultaneously with a mono subwoofer.

These connections are more complicated because they require the use of passive crossover networks (Not provided) to divide the frequencies to the speakers. We have included a sample diagram for 4 Ohm connections. If you wish to use multiple speakers to achieve a lower impedance and higher power, it is strongly recommended that you seek professional advice from your Profile retailer before attempting to make these connections.

Please Note: In the Tri-mode configuration, the amplifier's built-in crossover must be set to the "OFF" position so the speakers receive full range output.

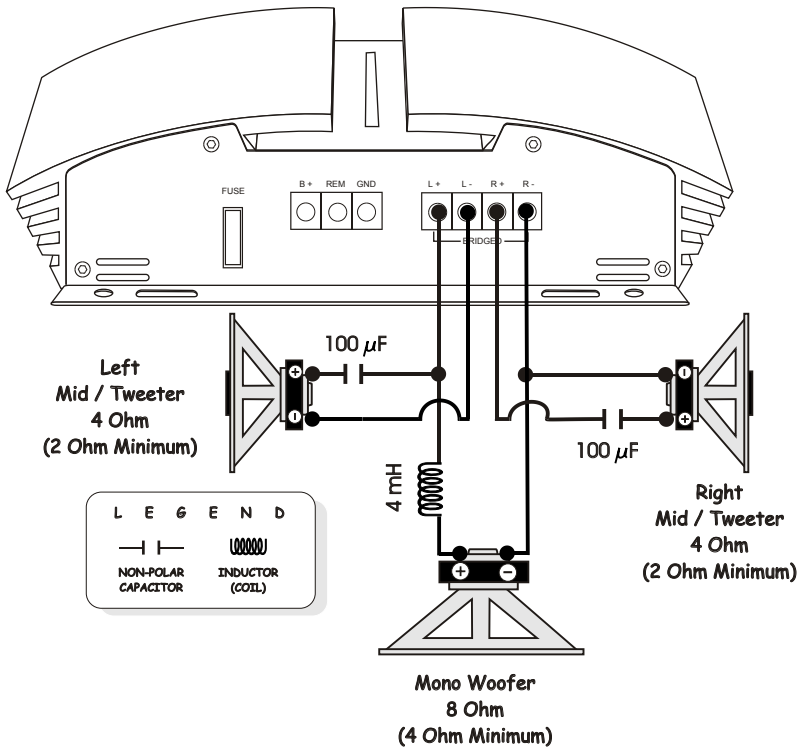

CAUTION! In Tri-mode operation, the amplifier must see a 2 Ohm load or higher for the stereo satellites and no lower than 4 Ohms for the subwoofer(s). Any lower than the above mentioned impedance will cause the amplifier to overheat and possibly cause permanent damage to the amplifier.



SETTING THE CROSSOVER AND BASS BOOST

Select your crossover type and frequency.

(Please note: If you intend to use the amplifier in the Tri-mode configuration, it is necessary to set the crossover control to the "Flat" setting in order to receive full range output)

The California amplifiers are equipped with a built-in variable crossover network allowing you to select the crossover type (i.e. Low-Pass or Hi-Pass) and the desired crossover point. For example if you wish to drive a pair of subwoofers, you can select the "Low Pass" setting on the amplifier to filter out high frequencies. This will send only low frequencies to your subwoofers (see example settings below). The crossover point should be determined by the speakers operating range. Please refer to speaker manufactures recommended crossover point.

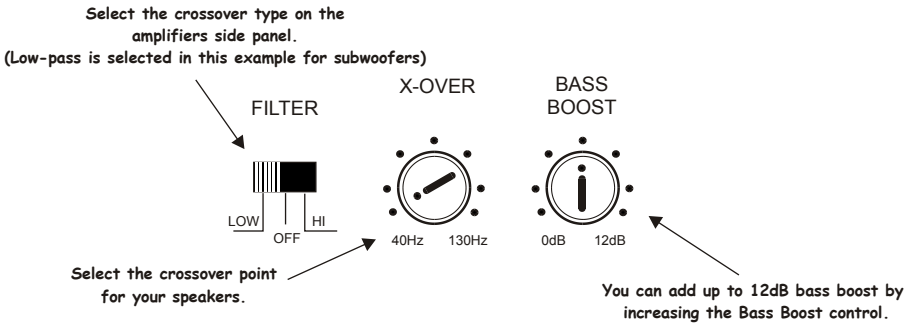

FINE TUNE THE SYSTEM

Fine tune the amplifier's input sensitivity.



Access to the gain sensitivity control for the California amplifier is located on the side panel. This gain control has been included to allow adjustment to properly match the output of the radio. This is one of the most misunderstood adjustments. By rotating the control in the clockwise direction, the amplifiers input will become more sensitive and

the music will play louder. This is not a volume control and you will not get more power out of the amplifier in the maximum position! It may seem to deliver more output, but actually the system is only playing louder faster as you turn the volume control on the radio. Ideally, to properly level match the system the goal is to achieve maximum output from the amplifier without distortion at about 3/4 of the volume control.

To determine if the amplifiers gain is set properly, turn the system on and slowly increase the volume control. You should be able to use about 3/4 volume before the system gets loud but not distorting. It is very important when making these adjustments that you do not over drive the speakers (at point of distortion) this will cause permanent damage to the speakers. If you are unable to achieve 3/4 volume before distortion you will need to adjust gain control (in this case you would reduce the gain). The gain controls should be adjusted very slowly. It may help to have another person to assist you by adjusting the gain controls while you listen for distortion.

TROUBLE SHOOTING THE SYSTEM

We have put together this trouble-shooting guide if you experience problems after installing the amplifier. Please keep in mind that the majority of problems incurred are caused by improper installation and not the equipment itself. In addition, there are many components in the system that could cause various signal problems such as inducted electrical noise and engine noise.

Before you can properly address the problem, you must first find the component that is causing the problem. This will take patience and a process of elimination.

LOOK FOR....

SOLUTION

No Output

Blown fuse	Replace
Bad RCA Cable(s)	Replace
+12V at power terminal	Check connection
+12V at remote terminal	Check connection
Grounding point clean and tight	Check for ground w/meter
Head Unit's fader not in center position	Set to center position

Low Output

Check level adjustments	Re-adjust
Bad RCA cable(s)	Replace
Improper level matching	Re-adjust

Engine Noise

Grounding points are clean and tight	Check for ground w/meter
Ground all components at same point	Ground at same point
Try different grounding point	Change for better ground
Bad RCA cable(s)	Replace
Use High Quality shielded RCA cables	Rejects inducted noise
Low Vehicle charging system and/or battery	Fix and/or replace

Protection L.E.D. Illuminated

Speaker short	Check speakers connection for short circuit
Speaker grounding out	Make sure speaker wires do not touch chassis ground
Impedance too low	Check speaker impedance (Min 2 ohm Stereo, 4 Mono)
Overheating	Check mounting location for Adequate air Circulation speaker impedance too low



SPECIFICATIONS

100SX

Output Power @ 4 Ohm	2 x 70 WATTS
RMS Power @ 4 Ohm	2 x 35 WATTS
RMS Power @ 2 Ohm	2 x 50 WATTS
Bridged RMS @ 4 Ohm	1 x 100 WATTS
THD @ RMS Power	<0.07%
Frequency Response	20Hz ~ 30KHz
Signal To Noise	>105dB
Stereo Separation	85dB
Low Level Input	175mV ~ 4.1V
Load Impedance Stereo2 ~ 8 Ohms
Load Impedance Bridged4 ~ 8 Ohms
Crossover Type (12dB/Octave)	High Pass / Low Pass / Full Range
Crossover Frequency (Variable)	40Hz ~ 130Hz
Bass Boost	0dB ~ 12dB @ 45Hz
Fuse Value	1 x 20A (ATC)
Size (L x W x H)	6 1/16" x 9 3/4" x 2 1/4"

200SX

Output Power @ 4 Ohm	2 x 120 WATTS
RMS Power @ 4 Ohm	2 x 60 WATTS
RMS Power @ 2 Ohm	2 x 90 WATTS
Bridged RMS @ 4 Ohm	1 x 180 WATTS
THD @ RMS Power	<0.07%
Frequency Response	20Hz ~ 30KHz
Signal To Noise	>105dB
Stereo Separation	85dB
Low Level Input	175mV ~ 4.1V
Load Impedance Stereo2 ~ 8 Ohms
Load Impedance Bridged4 ~ 8 Ohms
Crossover Type (12dB/Octave)	High Pass / Low Pass / Full Range
Crossover Frequency (Variable)	40Hz ~ 130Hz
Bass Boost	0dB ~ 12dB @ 45Hz
Fuse Value	1 x 25A (ATC)
Size (L x W x H)	8 11/16" x 9 3/4" x 2 1/4"

400SX

Output Power @ 4 Ohm	2 x 200 WATTS
RMS Power @ 4 Ohm	2 x 100 WATTS
RMS Power @ 2 Ohm	2 x 150 WATTS
Bridged RMS @ 4 Ohm	1 x 300 WATTS
THD @ RMS Power	<0.07%
Frequency Response	20Hz ~ 30KHz
Signal To Noise	>105dB
Stereo Separation	85dB
Low Level Input	175mV ~ 4.1V
Load Impedance Stereo2 ~ 8 Ohms
Load Impedance Bridged4 ~ 8 Ohms
Crossover Type (12dB/Octave)	High Pass / Low Pass / Full Range
Crossover Frequency (Variable)	40Hz ~ 130Hz
Bass Boost	0dB ~ 12dB @ 45Hz
Fuse Value	2 x 20A (ATC)
Size (L x W x H)	10 9/16" x 9 3/4" x 2 1/4"

600SX

Output Power @ 4 Ohm	2 x 300 WATTS
RMS Power @ 4 Ohm	2 x 150 WATTS
RMS Power @ 2 Ohm	2 x 225 WATTS
Bridged RMS @ 4 Ohm	1 x 450 WATTS
THD @ RMS Power	<0.07%
Frequency Response	20Hz ~ 30KHz
Signal To Noise	>105dB
Stereo Separation	85dB
Low Level Input	175mV ~ 4.1V
Load Impedance Stereo	.2 ~ 8 Ohms
Load Impedance Bridged	.4 ~ 8 Ohms
Crossover Type (12dB/Octave)	High Pass / Low Pass / Full Range
Crossover Frequency (Variable)	40Hz ~ 130Hz
Bass Boost	0dB ~ 12dB @ 45Hz
Fuse Value	2 x 25A (ATC)
Size (L x W x H)	12 ³ / ₁₆ " x 9 ³ / ₄ " x 2 ¹ / ₄ "

800SX

Output Power @ 4 Ohm	2 x 400 WATTS
RMS Power @ 4 Ohm	2 x 200 WATTS
RMS Power @ 2 Ohm	2 x 300 WATTS
Bridged RMS @ 4 Ohm	1 x 600 WATTS
THD @ RMS Power	<0.07%
Frequency Response	20Hz ~ 30KHz
Signal To Noise	>105dB
Stereo Separation	85dB
Low Level Input	175mV ~ 4.1V
Load Impedance Stereo	.2 ~ 8 Ohms
Load Impedance Bridged	.4 ~ 8 Ohms
Crossover Type (12dB/Octave)	High Pass / Low Pass / Full Range
Crossover Frequency (Variable)	40Hz ~ 130Hz
Bass Boost	0dB ~ 12dB @ 45Hz
Fuse Value	3 x 20A (ATC)
Size (L x W x H)	16 ¹ / ₈ " x 9 ³ / ₄ " x 2 ¹ / ₄ "

1200SX

Output Power @ 4 Ohm	2 x 600 WATTS
RMS Power @ 4 Ohm	2 x 300 WATTS
RMS Power @ 2 Ohm	2 x 450 WATTS
Bridged RMS @ 4 Ohm	1 x 900 WATTS
THD @ RMS Power	<0.07%
Frequency Response	20Hz ~ 30KHz
Signal To Noise	>105dB
Stereo Separation	85dB
Low Level Input	175mV ~ 4.1V
Load Impedance Stereo	.2 ~ 8 Ohms
Load Impedance Bridged	.4 ~ 8 Ohms
Crossover Type (12dB/Octave)	High Pass / Low Pass / Full Range
Crossover Frequency (Variable)	40Hz ~ 130Hz
Bass Boost	0dB ~ 12dB @ 45Hz
Fuse Value	4 x 20A (ATC)
Size (L x W x H)	24 ³ / ₈ " x 9 ³ / ₄ " x 2 ¹ / ₄ "



440SX

Output Power @ 4 Ohm	4 x 100 WATTS
RMS Power @ 4 Ohm	4 x 50 WATTS
RMS Power @ 2 Ohm	4 x 75 WATTS
Bridged RMS @ 4 Ohm	2 x 150 WATTS
THD @ RMS Power	<0.07%
Frequency Response	20Hz ~ 30Khz
Signal To Noise	>105dB
Stereo Separation	.85dB
Low Level Input	.175mV ~ 4.1V
Load Impedance Stereo	.2 ~ 8 Ohms
Load Impedance Bridged	.4 ~ 8 Ohms
Crossover Type (12dB/Octave)	High Pass / Low Pass / Full Range
Crossover Frequency (Variable)	.40Hz ~ 130Hz
Bass Boost	0dB ~ 12dB @ 45Hz
Fuse Value	1 x 30A (ATC)
Size (L x W x H)	1 1" x 9 3/4" x 2 1/4"

640SX

Output Power @ 4 Ohm	4 x 150 WATTS
RMS Power @ 4 Ohm	4 x 75 WATTS
RMS Power @ 2 Ohm	4 x 110 WATTS
Bridged RMS @ 4 Ohm	2 x 225 WATTS
THD @ RMS Power	<0.07%
Frequency Response	20Hz ~ 30Khz
Signal To Noise	>105dB
Stereo Separation	.85dB
Low Level Input	.175mV ~ 4.1V
Load Impedance Stereo	.2 ~ 8 Ohms
Load Impedance Bridged	.4 ~ 8 Ohms
Crossover Type (12dB/Octave)	High Pass / Low Pass / Full Range
Crossover Frequency (Variable)	.40Hz ~ 130Hz
Bass Boost	0dB ~ 12dB @ 45Hz
Fuse Value	2 x 25A (ATC)
Size (L x W x H)	12 13/16" x 9 3/4" x 2 1/4"

Due to continuing product improvements, specifications subject to change without notice.

PRFILE® LIMITED WARRANTY

Profile Consumer Electronics, Inc. warrants this product to be free from defects in material and workmanship for a period of **One (1) Year** from the date of sale to the original consumer purchaser. If this product is proven to be defective within this one year period, Profile will repair it when said product is returned, with a copy of the dated sales receipt, freight prepaid to Profile.

This warranty is valid only in the United States. This warranty does not cover any expense incurred in the removal and/or re-installation of this product. This warranty does not cover any Profile product damaged by accident, misuse, abuse, improper line voltage, fire, water, lightning, or other acts of God. This warranty is void if any parts and/or service is/are furnished by anyone other than Profile. This warranty is void if the factory applied serial number is altered or removed from the product.

This warranty does not cover cartons, cases, batteries, broken or marred cabinets, magnetic tapes, or any other accessories used in connection with this product or consequential damages due to a defect in the product.

Any implied warranties, including fitness for use and merchantability, are limited in duration to the period of the express warranty set forth above. No person is authorized to assume for Profile any other liability in connection with the sale of the product. Profile expressly disclaims liability for incidental and consequential damages that might be caused by this product. The remedies provided under this warranty are exclusive and lieu of all others.

This warranty gives you specific legal rights. You may have other rights which vary from state to state or province to province. Some states or provinces do not allow limitation on how long warranties last, so the above may not apply to you. Additionally, some states/provinces do not allow the exclusion to limitation of consequential or incidental damages, so the above limitation or exclusion may not apply to you.

* In the space below, record the model number that is located on the back of the unit along with the purchase date and location.

Model Number _____

Purchase Date _____ Where Purchased _____

RETAIN YOUR SALES RECEIPT ALONG WITH THIS CARD. IT IS YOUR ONLY VALID DOCUMENT TO RECEIVE WARRANTY SERVICE.

PROFILE® WARRANTY REPAIR POLICY

In the unlikely event of product failure, the following procedures should be followed

- 1) The unit must be under the 1-year warranty period.
- 2) The unit must have no physical damage.
- 3) A copy of the original proof of purchase must be sent with the unit.
- 4) Include a brief description of the problem or failure with the unit.
- 5) Include the return **street** address and daytime telephone number.
- 6) Allow 2~3 weeks for repair (this period includes shipping time).

Send unit to : **PROFILE CONSUMER ELECTRONICS, INC.**
 15060 SHOEMAKER AVE
 SANTA FE SPRINGS, CA 90670
 TEL: (562) 404-9393

Note: All units failing to meet the above requirements will be subject to a charge and or may not be repaired.



PROFILE CONSUMER ELECTRONICS, INC.
15060 SHOEMAKER AVE
SANTA FE SPRINGS, CA 90670
TEL: (562) 404-9393 • FAX: (562) 404-9433
WWW.PROFILEUSA.COM