



GEM[®] eM 1400

**2014 Owner's Manual
for Maintenance and Safety**

⚠ WARNING

Read, understand, and follow all of the instructions and safety precautions in this manual and on all product labels.

Failure to follow the safety precautions could result in serious injury or death.



Thank you for purchasing a GEM by POLARIS, and welcome to our world-wide POLARIS family of recreational and utility vehicle owners. We believe POLARIS sets a standard of excellence for all recreational and utility vehicles manufactured in the world today. With our many years of experience in design and manufacturing, we proudly bring you only the finest of vehicles:

- Snowmobiles
- All-terrain vehicles (ATVs)
- Low emission vehicles (LEVs)
- *RANGER*® utility vehicles
- *RZR*® sport vehicles
- *VICTORY*® motorcycles
- GEM® electric vehicles

For safe and enjoyable operation of your vehicle, be sure to follow the instructions and recommendations in this owner's manual. Your manual contains instructions for minor maintenance, but information about major repairs is outlined in the GEM Service Manual and should be performed only by an authorized GEM dealer technician.

If questions arise after reading the manual, please contact GEM customer service. Be prepared to provide your Vehicle Identification Number (VIN) and date of purchase.

Your authorized GEM dealer knows your vehicle best and is interested in your total satisfaction. Be sure to return to your dealership for all of your service needs during, and after, the warranty period.

GEM Customer Service

Phone: 855-RIDEGEM (855-743-3436)

Web: www.gemcar.com

POLARIS® and GEM® are registered trademarks of POLARIS Industries Inc.
Global Electric Motorcars® is a division of POLARIS.

Copyright 2013 POLARIS Sales Inc. All information contained within this publication is based on the latest product information at the time of publication. Due to constant improvements in the design and quality of production components, some minor discrepancies may result between the actual vehicle and the information presented in this publication. Depictions and/or procedures in this publication are intended for reference use only. No liability can be accepted for omissions or inaccuracies. Any reprinting or reuse of the depictions and/or procedures contained within, whether whole or in part, is expressly prohibited.

The original instructions for this vehicle are in English. Other languages are provided as translations of the original instructions.

Printed in U.S.A.

2014 GEM eM 1400 Owner's Manual

P/N 9924949

TABLE OF CONTENTS

Introduction	4
Safety	7
Features and Controls	16
Operation	26
Winch Guide	35
Maintenance	44
Specifications	60
Troubleshooting	61
Warranty	62
Maintenance Log	66
Index	68

INTRODUCTION

The GEM eM 1400 is a utility vehicle. Never operate on public roads. This vehicle does not meet National Highway Traffic Safety Administration (NHTSA) regulations for operation on public streets, roads and highways. Familiarize yourself with all laws and regulations concerning the operation of this vehicle in your area.

The following signal words and symbols appear throughout this manual and on your vehicle. Your safety is involved when these words and symbols are used. Become familiar with their meanings before reading the manual.



The safety alert symbol indicates a potential personal injury hazard.

DANGER

A DANGER indicates a hazardous situation that, if not avoided, will result in death or serious injury.

WARNING

A WARNING indicates a hazardous situation that, if not avoided, could result in death or serious injury.

CAUTION

A CAUTION indicates a hazardous situation that, if not avoided, could result in minor or moderate injury.

NOTICE

A NOTICE indicates a situation that could result in property damage.



The Prohibition Safety Sign indicates an action NOT to take in order to avoid a hazard.



The Mandatory Action Sign indicates an action that NEEDS to be taken to avoid a hazard.

⚠ WARNING

Failure to follow the warnings contained in this manual can result in severe injury or death. Special precautions must be followed when operating or servicing a battery-powered vehicle. This vehicle handles differently than other vehicles. A collision or rollover can occur quickly, even during routine maneuvers, if you fail to take proper precautions.

- Read this owner's manual. Understand all safety warnings, precautions and operating procedures before operating the vehicle. Keep this manual with the vehicle at all times.
- This vehicle is an **ADULT VEHICLE ONLY**. You **MUST** be at least age 16 and have a valid driver's license to operate this vehicle.
- No person under the age of 12 may ride as a passenger in this vehicle.
- Never permit a guest to operate this vehicle unless the guest has read this manual and all product labels.
- Never use this vehicle with drugs or alcohol, as these conditions impair judgment and reduce operator reaction time.

INTRODUCTION

Vehicle Identification Numbers

Record your vehicle's identification numbers and key number in the spaces provided below. The Vehicle Identification Number (VIN) indicates the model year, model type and serial number of your vehicle. The VIN is stamped on the left rear frame. The VIN is also on the manufacturer's label, which is located under the passenger seat. Gross Vehicle Weight information for your vehicle is on the Passenger/Tire Pressure Warning Label in the rear cargo box. See page 7.

To order an extra or replacement key for your vehicle, please contact GEM customer service. See page 1. Be prepared to provide your key number and VIN. Remove the spare key and store it in a safe place. A key can be duplicated only by ordering a key blank (using your key number) and mating it with one of your existing keys. The key switch must be replaced if all keys are lost.

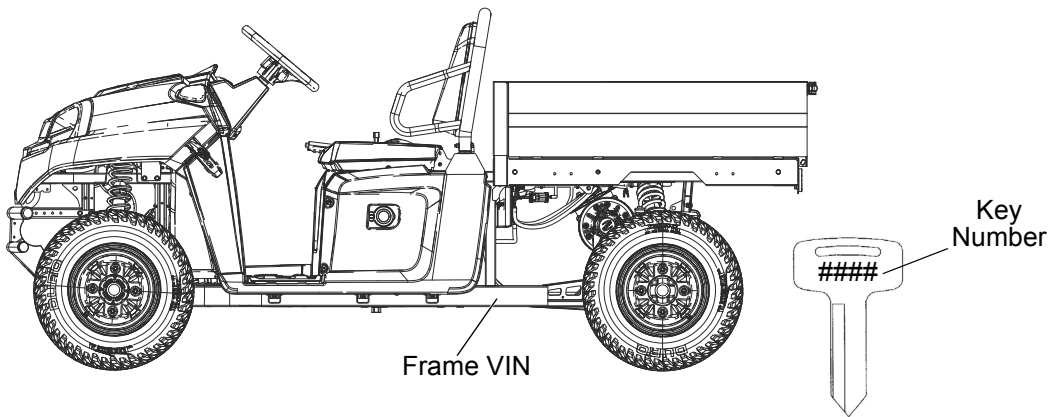

Vehicle Model Number: _____

Frame VIN: _____

Motor Serial Number (on side of motor): _____

Key Number: _____

Safety Labels and Locations

Warning labels have been placed on the vehicle for your protection. Read and follow the instructions of the labels on the vehicle carefully. If any of the labels depicted in this manual differ from the labels on your vehicle, always read and follow the instructions of the labels *on the vehicle*.

If any label becomes illegible or comes off, contact your GEM dealer to purchase a replacement. Replacement *safety* labels are provided at no charge. The part number is printed on the label.

Passenger/Tire Pressure Warning

WARNING

- Passengers can be thrown off. This can cause serious injury or death.
- Never carry passengers in cargo box.

WARNING

IMPROPER TIRE PRESSURE OR OVERLOADING CAN CAUSE LOSS OF CONTROL RESULTING IN SERIOUS INJURY OR DEATH.

- Reduce speed and allow greater distance for braking when carrying cargo.
- Overloading or carrying tall, off-center, or unsecured loads will increase your risk of losing control. Loads should be centered and carried as low as possible in box.
- For stability on rough or hilly terrain, reduce speed and cargo.
- Be careful if load extends over the side of the box.

Passenger/Tire Pressure Warning
(inside box on front panel)

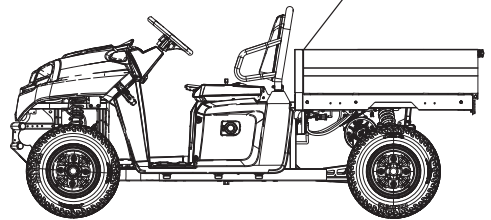

GEM eM 1400	BASE	BASE WITH SIDES	BASE WITH VAN ENCLOSURE
TIRE PRESSURE IN PSI (KPa)	FRONT 32 (220) REAR 32 (220)	FRONT 32 (220) REAR 32 (220)	FRONT 32 (220) REAR 32 (220)
VEHICLE OPERATING WEIGHT	1500 lbs. (680 kg)	1555 lbs. (705 kg)	1625 lbs. (737 kg)
MAXIMUM CARGO PAYLOAD	1100 lbs. (499 kg)	1045 lbs. (474 kg)	975 lbs. (442 kg)
GVW = VEHICLE + OCCUPANTS + PAYLOAD + ACCESSORIES	2950 lbs. (1338 kg)	2950 lbs. (1338 kg)	2950 lbs. (1338 kg)
Read Operation and Maintenance Manual for more detailed loading information.			

7180345

SAFETY

Safety Labels and Locations



Age 16 Warning

Operating this vehicle if you are under the age of 16 increases your chance of severe injury or death. NEVER operate this vehicle if you are under age 16 and NEVER operate this vehicle without a valid driver's license.

7175566

Discretionary Warning

WARNING

Improper vehicle use can result in Severe Injury or Death.

NEVER Operate:

- At speeds too fast for your skills or the conditions.
- After or while using Alcohol or Drugs.
- On extreme off-road terrain or extreme slopes.
- On public roads, a collision can occur with a another vehicle.
- With more than one passenger, or a passenger under age twelve or who cannot comfortably reach the floor and hand holds.
- With non-GEM approved accessories - they may seriously affect stability.

ALWAYS:

- Wear your seat belt, if equipped. Vehicle rollover could cause severe injury or death.
- Wear a helmet and eye protection and keep hands and feet in vehicle at all times.
- Reduce speed and use extra caution when carrying a passenger.
- Avoid sharp turns or turns while applying heavy throttle.
- Operate slowly in reverse - avoid sharp turns or sudden braking.
- Make sure passenger reads and understands all safety labels.
- Watch for branches or other hazards that could enter vehicle.

LOCATE AND READ OWNER'S MANUAL. FOLLOW ALL INSTRUCTIONS AND WARNINGS.

7180342

Safety Labels and Locations

Battery Caution

CAUTION

- Do not drive through water above the floor of the vehicle. Battery damage will occur.
- Batteries require regular maintenance.
- Failure to maintain batteries in accordance with the owners manual can result in battery damage, vehicle malfunction, fire and/or severe injury or death.
- Max towing speed 10 MPH (16 km/h) - drivetrain damage will occur if towed faster than 10 MPH (16 km/h).
- Set parking brake before leaving vehicle.
- Turn Power On key to "Off" position and remove when not in use.
- When towing vehicle, turn Power On key to "Off" position.

7176204

Battery Charging Warning

WARNING

- Explosive gases are released when batteries are charged. Keep sparks, flames and cigarettes away. Shield eyes when working near batteries.
- Do not charge batteries in a non-ventilated enclosed area or near flammable materials.
- Do not attempt to charge frozen, leaking, or damaged batteries.
- Connect battery charger to properly rated electrical receptacle with GFCI.
- Do not charge with storage or weather cover on vehicle or with the cab enclosure doors closed, as fire and explosion are possible.
- Refer to Owner's Manual or contact your local dealer with any questions.



TO MAXIMIZE BATTERY LIFE

- Always check and maintain water level monthly. Use only distilled water. Water level should be kept 1/4" (6 mm) below fill well. Do not overfill the battery.
- Always keep batteries fully charged. For maximum life, charge your vehicle at every opportunity. Use only the charger supplied with the vehicle. Inspect battery connections regularly.
- Failure to properly maintain your batteries will void warranty coverage.

7176414

Battery Compartment Warning

WARNING

- **SULFURIC ACID** in batteries will burn skin, eyes, and clothing. Always wear eye protection and proper clothing. Do not tip batteries. Keep vent caps tight and level. In event of injury, flush with water and call physician immediately.
- **HIGH VOLTAGE CABLES** and terminals are contained within this compartment. Improper contact between battery terminals can result in electrical shorts. **ELECTRICAL SHORTS** can result in burns.
- Do not use high pressure water to wash the battery compartment. Damage to the vented batteries will result.
- Tampering with or unauthorized modification of this unit could result in serious personal injury, will void the warranty, and can result in permanent damage to the vehicle.
- Refer to your Owner's Manual or contact your local GEM dealer with any questions.

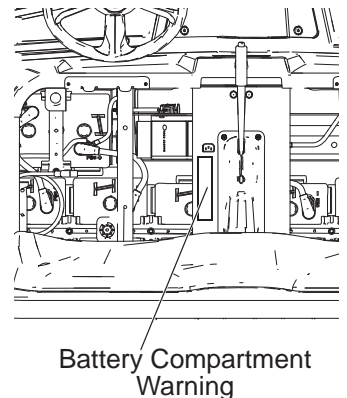

7180344

SAFETY

Personal Protective Equipment

Always wear the proper clothing when operating or riding in this vehicle. All riders should wear substantial footwear, long pants and a close-fitting shirt. A hard hat or helmet and approved eye protection are recommended when appropriate for working or riding conditions. GEM recommends wearing approved eye protection bearing markings such as VESC 8, V-8, Z87.1 or CE. Never operate or ride in this vehicle while barefoot or while wearing sandals or tennis shoes.

Workplace safety regulations may require the use of safety glasses, safety shoes and a hard hat or helmet. Familiarize yourself with local requirements, be prepared for operating conditions and wear the appropriate safety gear.

Operator Safety

WARNING

Serious injury or death can result if you do not follow these instructions and procedures, which are outlined in further detail within your owner's manual.

- Read this entire manual and all labels carefully. Follow the operating procedures described.
- Never allow anyone under the age of 16 to operate this vehicle and never allow anyone without a valid driver's license to operate this vehicle.
- Always make sure the seat belts (if equipped) are secured for operator and passenger before operating.
- Never permit a guest to operate this vehicle unless the guest has read this manual and all product labels.
- Do not carry a passenger until you have at least two hours of driving experience with this vehicle.
- No person under the age of 12 may ride as a passenger in this vehicle.
- Never carry more than one passenger in this vehicle.
- Never exceed the stated load capacity for this vehicle. Cargo should be properly distributed and securely attached. Reduce speed and follow the instructions in this manual for hauling cargo or pulling a trailer. Allow a greater distance for braking.
- This vehicle is a utility vehicle. Never operate on public roads.
- Always be sure there are no obstacles or people behind your vehicle when operating in reverse. When it's safe to proceed in reverse, move slowly. Avoid turning at sharp angles in reverse.
- Always use the proper size and type of tires specified in this manual. Always maintain proper tire pressure as specified on safety labels.

Operator Safety

- Never modify this vehicle through improper installation or use of non-GEM-approved accessories.
- Always set the park brake and remove the key when leaving the vehicle unattended.
- The voltage in the battery pack is sufficient to cause death by electrocution. With the exception of battery inspections and refilling the water in flooded type batteries, never attempt to perform service on the electric drive system, including the battery pack. See your GEM dealer.
- Always keep hands and feet inside the vehicle at all times. Always keep both hands on the steering wheel (driver) and both feet on the floorboards of the vehicle during operation.
- Never consume alcohol or drugs before or while operating this vehicle.
- Never operate at excessive speeds. Always operate at a speed that's appropriate for the traffic, the visibility and operating conditions, your skills and your passenger's skills.
- Always inspect the vehicle before each use to make sure it's in safe operating condition. Always follow the inspection procedures described in this manual.
- Always travel slowly and use extra caution when operating on unfamiliar terrain. Be alert to changing terrain.
- Always follow proper procedures for turning. Make turns slowly, especially when the ground is wet, greasy, bumpy or sloping. Never turn the steering wheel abruptly when driving at high speed.
- Always have this vehicle checked by an authorized GEM dealer if it has been involved in an accident.
- Always be alert for obstacles when operating this vehicle. Never attempt to operate over obstacles.
- Do not drive through water above the floor of the vehicle. Battery damage will occur.
- Never operate this vehicle on steep hills.
- Never operate on excessively rough, slippery or loose terrain.
- Always be careful of skidding or sliding. On slippery surfaces such as ice, travel slowly and exercise caution to reduce the chance of skidding or sliding out of control.
- Always be sure there are no obstacles or people behind your vehicle when operating in reverse. When it's safe to proceed in reverse, move slowly. Avoid turning at sharp angles in reverse.

SAFETY

Operator Safety

Gross Vehicle Weight Rating (GVWR)

WARNING! Exceeding the gross vehicle weight rating of your vehicle can reduce stability and handling and could cause loss of control. NEVER exceed the GVWR of your vehicle.

The maximum *payload capacity* of your vehicle is the maximum weight you may add to your vehicle *without exceeding the GVWR*. This capacity is determined by calculating the difference between your vehicle's GVWR and wet weight.

Refer to the specification section of this manual or the Manufacturer's Label on the vehicle for model-specific information.

When determining the weight you will be adding to your vehicle, and to ensure you do not exceed the maximum payload capacity, include the following:

- operator body weight
- passenger body weight
- weight of all occupants' apparel and items in or on apparel
- weight of any options or accessories *and their contents*
- weight of any additional cargo on the vehicle

Equipment Modifications

Never install any accessory that grounds to the vehicle chassis. The chassis is a floating ground to protect against electrical short circuits and hazards.

Do not install any non-GEM-approved accessory or modify the vehicle for the purpose of increasing speed or power. Any modifications or installation of non-GEM-approved accessories could create a substantial safety hazard and increase the risk of bodily injury.

The warranty on your GEM vehicle will be terminated if any non-GEM-approved equipment and/or modifications have been added to the vehicle that increase speed or power.

The addition of certain accessories, including (but not limited to) mowers, blades, tires, sprayers, or large racks, may change the handling characteristics of the vehicle. Use only GEM-approved accessories, and familiarize yourself with their function and effect on the vehicle.

Operator Safety

⚠ WARNING

Failure to operate this vehicle properly can result in a collision, loss of control, accident or rollover, which may result in serious injury or death. Heed all safety warnings outlined in this section of the owner's manual. See the OPERATION section of the owner's manual for proper operating procedures.

Age Restrictions

This vehicle is an ADULT VEHICLE ONLY. NEVER operate this vehicle if you are under age 16 and NEVER operate without a valid driver's license.

Never operate with a passenger under the age of 12.



Protective Apparel

Always wear the proper clothing when operating or riding in this vehicle. All riders should wear substantial footwear, long pants and a close-fitting shirt. A hard hat or helmet and approved eye protection are recommended when appropriate for working or riding conditions. GEM recommends wearing approved eye protection bearing markings such as VESC 8, V-8, Z87.1 or CE. Never operate or ride in this vehicle while barefoot or while wearing sandals or tennis shoes.

Operating Without Instruction

Operating this vehicle without proper instruction increases the risk of an accident. The operator must understand how to operate the vehicle properly in different situations and on different types of terrain.

All operators must read and understand the Owner's Manual and all warning and instruction labels before operating the vehicle.

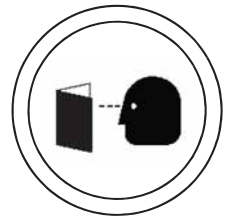

Using Alcohol or Drugs

Operating the vehicle after consuming alcohol or drugs could adversely affect operator judgment, reaction time, balance and perception.

Never drink alcohol or use drugs or medications before or while operating this vehicle.



SAFETY

Operator Safety

Ventilation When Charging Batteries

Failure to provide adequate ventilation while charging batteries can result in an explosion. Volatile hydrogen gas is emitted during charging and may accumulate in pockets at the ceiling.

- Always ensure a minimum of 5 air changes per hour in the charging area.
- Always remove any storage covers from the vehicle and open any cab doors (if equipped) before charging.
- If the charger turns off due to an overheated condition (thermal cutback), remove the seat to improve air flow. Reset the charger (interrupt AC power for 15 seconds).

Failure to Inspect Before Operating

Failure to inspect and verify that the vehicle is in safe operating condition before operating increases the risk of an accident. Always perform the pre-ride inspection before each use of your vehicle to make sure it's in safe operating condition. See page 26.

Always follow all inspection and maintenance procedures and schedules described in this owner's manual. See page 44.

Operating With a Load on the Vehicle

The weight of both cargo and passengers impacts vehicle operation. For your safety and the safety of others, carefully consider how your vehicle is loaded and how to safely operate the vehicle. Follow the instructions in this manual for loading, tire pressure, gear selection and speed.

- **Do not exceed vehicle weight capacities.** The vehicle's maximum weight capacity is listed in the specifications section of this manual and on a label on the vehicle. When more passenger weight is added, cargo weight may need to be reduced accordingly.
- The recommended tire pressures are listed in the specifications section of this manual and on a label on the vehicle.

Always follow these guidelines:

Under ANY of these conditions:	Do ALL of these steps:
Passenger and/or cargo exceeds half the maximum weight capacity	1. Slow down. 2. Verify tire pressure. 3. Use extra caution when operating.
Operating in rough terrain	
Operating over obstacles	
Climbing an incline	
Towing	

Operating a Damaged Vehicle

Operating a damaged vehicle can result in an accident. After any accident, have a qualified service dealer inspect the entire machine for possible damage, including (but not limited to) brakes, accelerator, steering system and electrical system.

Operating at Excessive Speeds

Operating this vehicle at excessive speeds increases the operator's risk of losing control. Always operate at a speed that's appropriate for the traffic, the visibility and operating conditions, your skills and your passenger's skills.

Vehicle Rollover

Vehicle rollover could cause serious injury or death. Always make sure the seat belts (if equipped) are secured for operator and passenger before operating. Avoid situations that could result in a rollover. Avoid sharp turns and abrupt steering maneuvers.

Operator Safety

Operating on Public Roads

This vehicle does not meet National Highway Traffic Safety Administration (NHTSA) regulations for operation on public streets, roads and highways. Operating this vehicle on public streets, roads or highways could result in a collision with another vehicle. Never operate this vehicle on any public street, road or highway, including dirt and gravel roads.

Driving Through Water

Do not drive through water above the floor of the vehicle. Battery damage will occur.

Turning Improperly

Turning improperly could cause loss of traction, loss of control, accident or rollover. Always follow proper procedures for turning as described in this owner's manual. Never turn abruptly or at sharp angles. Never turn at high speeds. Practice turning at slow speeds before attempting to turn at faster speeds.

Jumps and Stunts

Exhibition driving increases the risk of an accident or rollover. Never attempt wheelies, jumps, doughnuts or other stunts. Avoid exhibition driving.

Unauthorized Use of the Vehicle

Leaving the keys in the vehicle can lead to unauthorized use of the vehicle by someone under the age of 16, without a drivers license, or without proper training. This could result in an accident or rollover. Always remove the key when the vehicle is not in use.

Hot Drive Systems

The motor and controller are very hot during and after use of the vehicle. Hot components can cause burns and fire. Do not touch hot drive system components. Always keep combustible materials away from the drive system. Use caution when traveling through tall grass, especially dry grass. Always inspect areas near the drive system after driving through tall grass, weeds, brush and other tall ground cover. Promptly remove any grass or debris clinging to the vehicle.

Washing the Vehicle

Liquids can damage electrical components and the circuit board. Handle liquids with care. Do not spray water directly into areas that contain batteries or electrical components.

Precautions During Maintenance

WARNING! Do not work in or near the battery compartment or on any other electrical component of the vehicle while charging the batteries. Always disconnect the main power connector before servicing or unplugging any electrical components. See page 24.

Always follow all safety instructions in the maintenance portion of this owner's manual, as well as the following:

- Make sure the vehicle is properly immobilized before beginning any maintenance.
- Always block the chassis securely before working under the vehicle.
- Turn the key off and remove it from the vehicle.
- Insulate any tools used within the battery area to prevent sparks or battery explosion caused by shorting the battery terminals or wiring. Remove the batteries, or cover the exposed terminals with an insulating material.

**FOR MORE INFORMATION ABOUT SAFETY
PLEASE CONTACT GEM CUSTOMER SERVICE. See page 1.**

FEATURES AND CONTROLS

Component Locations

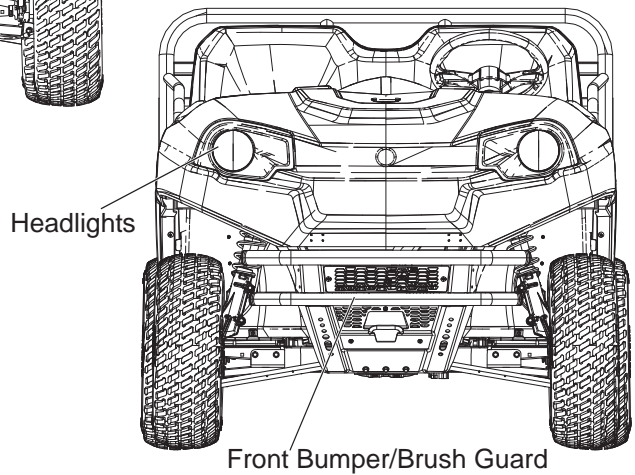
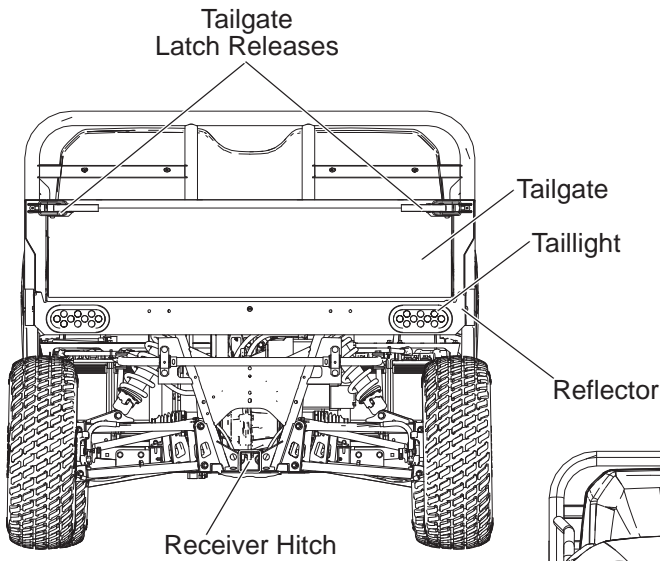
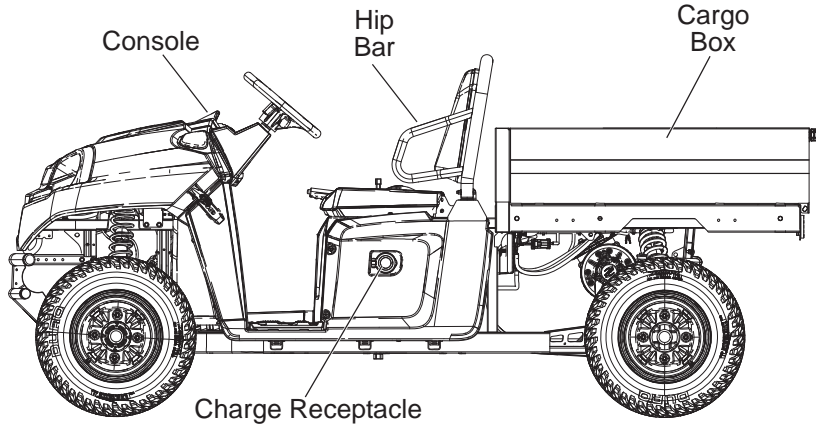

FEATURES AND CONTROLS

Console

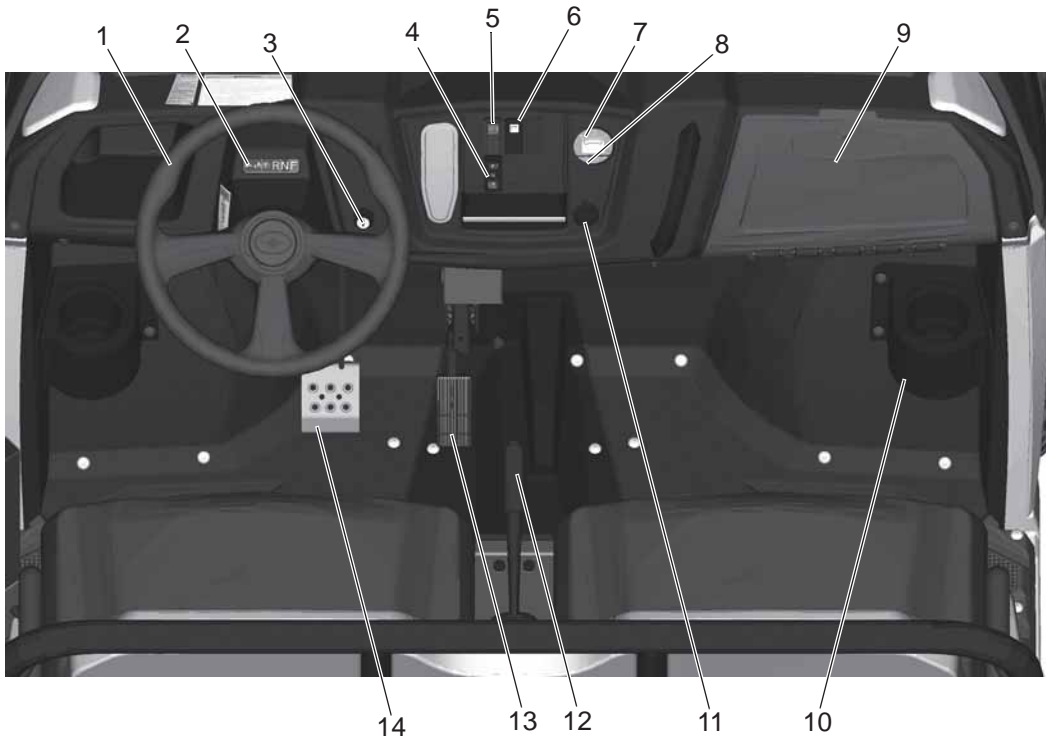

1. Steering Wheel
2. Indicator Lights
3. Key Switch
4. Direction Selector
5. Headlight Switch
6. Charge Status Indicator
7. Battery Discharge Indicator
8. Hour Meter
9. Glove Box/Storage Compartment
10. Beverage Holder
11. 12V Auxiliary Outlet
12. Park Brake Lever
13. Throttle Pedal
14. Brake Pedal

FEATURES AND CONTROLS

Console

Battery Discharge Indicator

The battery discharge indicator displays the amount of charge *removed (used) from fully charged batteries*. When the batteries are fully charged, the gauge will display 100%. The charge status indicator will be solid green (see page 19).

Avoid discharging the batteries more than 80%.



Hour Meter

The hour meter records and displays the hours of actual “key on” time since manufacture.

Auxiliary 12-Volt Terminal Board

The 12-volt terminal board is located under the hood. It contains constant 12-volt, switched 12-volt and ground terminals that can be used to power auxiliary lights and accessories. The terminals are limited to 10 amps.

Auxiliary Outlets

The 12-volt receptacle can be used to power accessories, but is limited to 10 amps (the terminal board and 12-volt outlet are fused together at 10 amps).

Direction Selector Switch

When the direction selector is in the center position, the vehicle is in neutral. The vehicle will not move if the accelerator is depressed.

Push the top of the switch to choose forward operation. Push the bottom of the switch to choose reverse operation. Always come to a complete stop before reversing direction.

Tip: The malfunction light will illuminate after reversing direction if you press the accelerator pedal before coming to a complete stop.

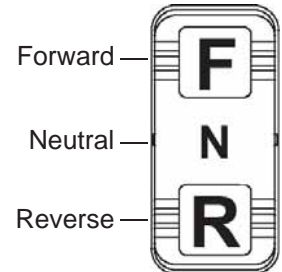

Headlight Switch

Press the top of the switch to turn the headlight on. Press the bottom of the switch to turn the headlight off.

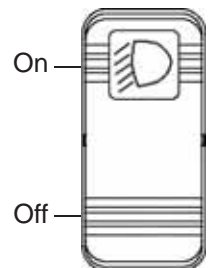

FEATURES AND CONTROLS

Console

Park Brake Lever

To help prevent the vehicle from rolling, set the park brake when parking the vehicle. When the park brake is set and the park brake indicator is illuminated, motor speed is limited. If the accelerator is applied, this limiting feature prevents operation, which protects the park brake pads from excessive wear.

Tip: This feature will not operate properly if the park brake connector or switch (under the hood) malfunctions or becomes disconnected, or if the switch has moved. Check for disconnection, then see your dealer promptly if this feature fails to operate properly.

Always apply the service brakes before engaging or releasing the park brake.

1. Apply the brakes.
2. Pull the park brake lever upward as far as possible.
3. To release the park brake, apply the brakes. Press the park brake lever release inward and move the lever downward as far as possible.

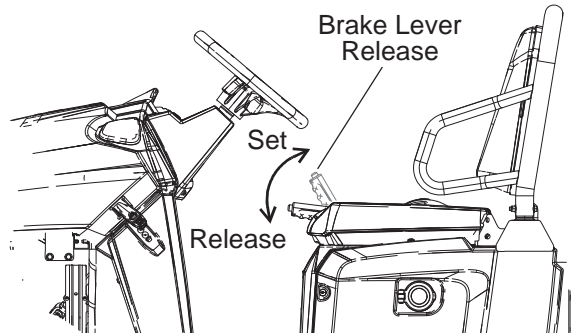

Charge Status Indicator

When charging the batteries, the charge status indicator light flashes and changes color to indicate the status of the charge. Refer to the table below.

Color	Indication	Code Definition
Green	Solid	Charge is complete, charger is in maintenance mode.
Green	Fast Flash	Less than 80% of charge is completed.
Green	Slow Flash	More than 80% of charge is completed.
Amber	Flashing	Power mode is reduced, low AC voltage or high internal charger temperature exists; remove seat to improve air flow.
Red	Flashing	Charger error exists; reset charger power and refer to Troubleshooting Guide on page 21.

Key Switch

Turn the key to the ON position to activate the electrical circuits.

Turn the key to the OFF position to disable all electrical circuits. The key can be removed from the switch when it is in the OFF position.

To prevent unnecessary battery drain, turn the key to the OFF position when the vehicle is idle. Always set the park brake and remove the key when leaving the vehicle unattended.

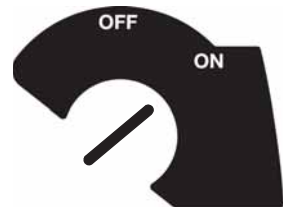

FEATURES AND CONTROLS

Console

Indicator Panel Lights

The indicator lights activate when the key is in the ON position.

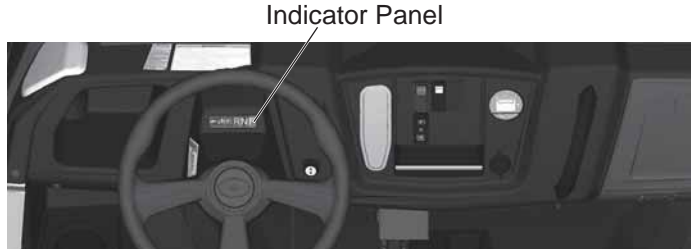

Indicator	Status	Indicates
Malfunction	Steady	Electrical malfunction (flash sequence on controller indicates type; see troubleshooting guide on page 21)
		Accelerator pedal is pressed while key is being turned on (release pedal to extinguish lamp)
		Charger is plugged in (vehicle will not operate when charging; unplug charger, wait for charge indicator to turn off before operating)
Park Brake	Steady	Engaged park brake
Gear Position	Steady	Selected gear (forward/neutral/reverse)
Motor/Controller High Temperature	Flashing	Reduced performance due to elevated temperature
	Steady	Power delivery terminated to protect against overheating
	<i>If either occurs, stop the vehicle and turn the key off. Allow the motor and controller to cool adequately before operating.</i>	

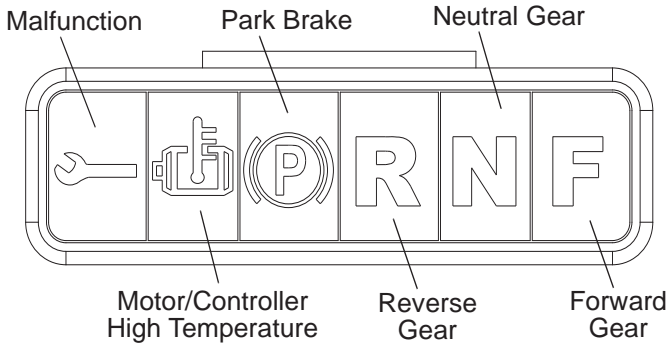

FEATURES AND CONTROLS

Malfunction Indicator Troubleshooting Guide

The malfunction codes will blink on the controller. The code definitions provided here are for informational purposes only.

Tip: If the indicator illuminates due to a minor issue such as a low voltage condition or a sequence fault (reversing direction without releasing the accelerator, turning the key on while in forward or reverse), select neutral and turn the key off and on to clear the error. If the error does not clear, please see your GEM dealer for diagnosis and repair.

# of Blinks	Code Definition
1	Data or configuration error
2	Sequence fault
3	Power fault
4	Contactors issue
6	Throttle input error
7	Voltage protection
8	Controller or motor out of temperature range
13	Software fault

Charge Status Indicator Troubleshooting Guide

The code definitions provided are for informational purposes only. Please see your GEM dealer for diagnosis and repair.

# of Blinks	Code Definition	Solution
1	Battery high voltage	Check battery size and condition; reset charger (interrupt AC power for 15 seconds)
2	Battery low voltage	
3	Charge time-out, battery pack not reaching required voltage, charger output reduced due to high temperatures	Check connections; operate charger at lower ambient temperature
4	Battery could not be trickle-charged to minimum voltage	Check battery for shorted or damaged cells
5	Charger shut down due to overheating	Ensure sufficient cooling air flow (remove the seat) and reset the charger (interrupt AC power for 15 seconds)
6	Charger internal fault	Reset charger (interrupt AC power for 15 seconds); return to qualified service provider if fault persists

FEATURES AND CONTROLS

Batteries

This vehicle is equipped with eight 6-volt batteries that supply the power needed to operate the vehicle. The batteries are located under the seat. See page 55 for battery access instructions.

Always observe all battery safety warnings and safe handling procedures as outlined on vehicle safety labels and in this manual. Refer to the battery maintenance section beginning on page 54.

Battery Handling Precautions

- Always make sure that all electrical accessories are grounded directly to the negative (-) post on the terminal board. Never use the chassis or body as a ground connection.
- Always keep battery terminals and connections clean and free of corrosion at all times. See page 56.
- Always maintain a full charge on the batteries. For best battery life, avoid discharging the batteries more than 80%. See page 18.
- Make sure new batteries are fully charged before using.
- New deep cycle batteries need to be cycled several times before reaching full capacity (50-125 cycles, depending on type). Capacity will be limited during this time.
- Make sure vent caps are installed properly and securely during vehicle operation and battery charging.
- Recharge batteries fully at the end of each day the vehicle is operated, allowing adequate time for the charger to complete its charge cycle. The batteries in this vehicle do not have a “memory effect”. Frequent charging will extend their life.
- Avoid charging at temperatures above 120° F. (49° C.) ambient air temperature. Closed, unvented storage buildings often exceed this temperature when exposed to direct sunlight.
- Never connect an auxiliary battery to the factory-installed DC-to-DC converter. If more than 10 amps are needed for accessories, always install the GEM-approved auxiliary accessory battery kit.
- Never connect a 12-volt accessory directly to the batteries. Always connect any powered accessory to a 12-volt auxiliary outlet or terminal board. See page 18.
- Never connect jumper cables to any of the batteries of this vehicle.
- Use only insulated tools when working in the battery compartment.

FEATURES AND CONTROLS

Batteries

Battery Conditioning

New batteries cannot initially hold all of their capacity. The approximate capacity of the battery pack increases as the number of charge cycles increases.

# of Charge Cycles:	New	15	30	45
Percent of Full Capacity:	80%	90%	95%	100%

Ambient Temperature Implications on Batteries

1. Battery range decreases as ambient temperature decreases. This can affect the range by up to 30%.
2. Batteries discharge when left uncharged. They can discharge up to 13% per month (higher rates in warmer climates) with the key off and much faster if the key is left on.
3. Batteries can freeze if left uncharged at low ambient temperatures.

Percent Charged:	100%	50%	0%
Approximate Freezing Point:	-60° F (-51° C)	0° F (-18° C)	25° F (-4° C)

Charger Operation

Open the hood and any door enclosures or zippers. This will decrease charger temperature, which allows it to operate more efficiently, and shorten charge times. See pages 54-55 for charging procedures. The battery charge receptacle is located on the left side panel below the driver's seat.

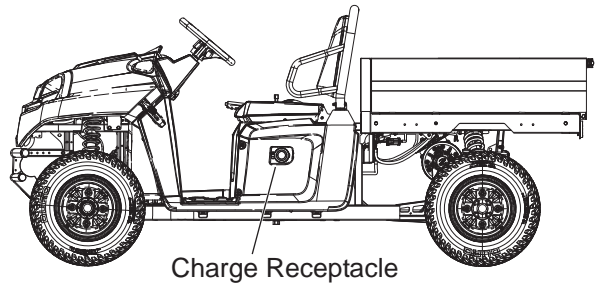

1. Always use extension cords with the appropriate ratings for the country in which it is used. In North America this is a UL rating. The cords must also be rated for the conditions in which they are used, such as being rated for protection from oil in a garage or workshop environment.
2. Use the proper cord wire gauges for the cord length used:

Length:	<25 ft (7.5 m)	<50 ft (15 m)	<100 ft (30 m)
Gauge:	16AWG (1.5mm ²)	14AWG (2.5mm ²)	10AWG (6.0mm ²)

Battery Operation Range

Range is significantly affected by tire pressure, alignment, terrain and driving style. Always maintain proper tire pressure as specified on safety labels.

FEATURES AND CONTROLS

Main Power Connector

NOTICE: Damage to electrical connections and components will occur if they are unplugged before the main power connector is disconnected. Always disconnect the main power connector before servicing or unplugging any electrical components.

When disconnected, the main power connector disconnects the battery pack from all electrical components, with the exception of the contactor. After servicing the vehicle, the main power connector should be the last connection to be made.

The main power connector is located under the seat on the passenger side of the vehicle, adjacent to the main line contactor. To disconnect, unplug the connector.

WARNING! Insulate any tools used within the battery area to prevent sparks or battery explosion caused by shorting the battery terminals or wiring. Remove the batteries, or cover the exposed terminals with an insulating material.

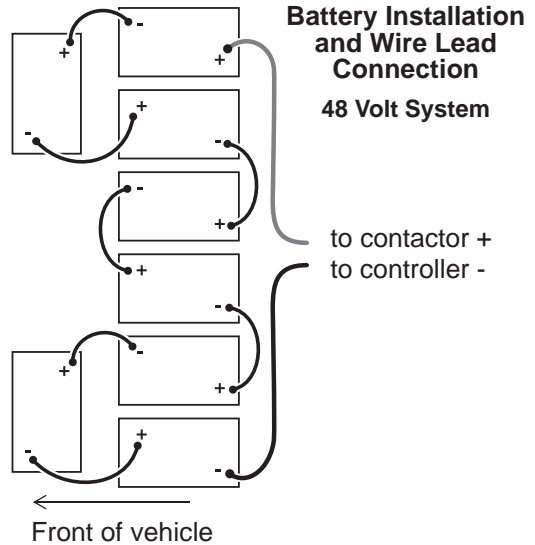
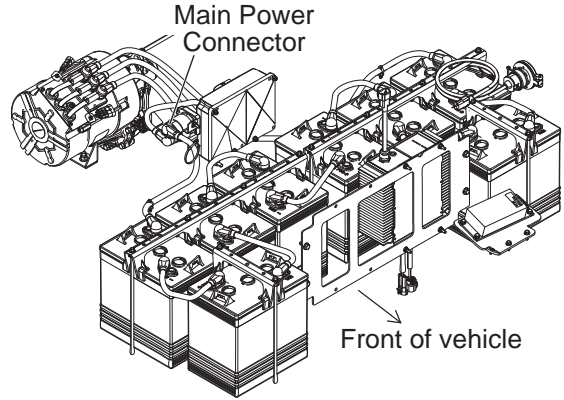

FEATURES AND CONTROLS

Brake Pedal

Push the brake pedal toward the floor to slow or stop the vehicle. Apply the brakes before turning the key on.

Accelerator Pedal

The accelerator pedal will function only when the key is ON and the direction selector switch is set to either forward or reverse. To begin moving or to increase vehicle speed, gradually press the accelerator pedal toward the floor. Holding the accelerator pedal down continuously will accelerate the vehicle to the maximum speed.

To slow the vehicle, release the accelerator pedal. Electric motor braking provides braking when the pedal is released. For additional speed control or to stop the vehicle, apply the service brakes.

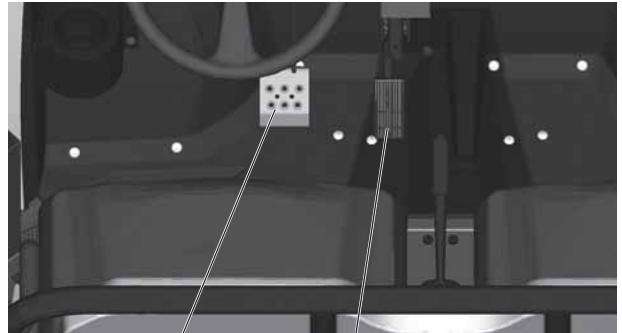

Brake Pedal

Accelerator Pedal

Seat Removal

Pull upward on the rear of the seat to disengage the latches. Slide the seat rearward and lift it away from the seat base.

To reinstall the seat, align the front seat tabs with the slots on the front of the seat base. Slide the seat fully forward, then push down firmly along the rear edge of the seat to secure the latches.

Trailer Hitch Bracket

This vehicle is equipped with a receiver hitch bracket for a trailer hitch. Trailer towing equipment is not supplied with this vehicle.

To avoid injury and property damage, always heed the warnings and towing capacities outlined on pages 31-32.

OPERATION

WARNING

Failure to operate the vehicle properly can result in a collision, loss of control, accident or rollover, which may result in serious injury or death. Read and understand all safety warnings outlined in the safety section of this owner's manual.

Pre-Ride Inspection

Failure to inspect and verify that the vehicle is in safe operating condition before operating increases the risk of an accident. Always inspect the vehicle before each use to make sure it's in safe operating condition.

Item	Remarks	Page
Brake system/pedal travel	Ensure proper operation	25 47
Brake fluid	Ensure proper level	47
Front suspension	Inspect, lubricate if necessary	-
Rear suspension	Inspect, lubricate if necessary	-
Steering	Ensure free operation	48
Tires	Inspect condition and pressure	7 49
Wheels/fasteners	Inspect, ensure fastener tightness	49
Frame nuts, bolts, fasteners	Inspect, ensure tightness	-
Accelerator	Ensure proper operation	25
Indicator lights/switches	Ensure operation	20
Headlamp	Check operation, apply dielectric grease when lamp is replaced	51
Brake light/tail lamp	Check operation, apply dielectric grease when lamp is replaced	52
Latches (hood/tailgate/seat)	Ensure all latches are secure	-
Batteries	Ensure full charges, proper water levels, clean terminals	54-56
Battery cables	Inspect for proper cable routing and secure connections	55

Driving Procedure

1. Disconnect the charging cable (if connected).
 2. All riders should wear substantial footwear, long pants and a close-fitting shirt. A hard hat or helmet and approved eye protection are recommended when appropriate for working or riding conditions.
 3. Sit in the driver's seat.
 4. Apply the brakes. Place the direction selector in neutral (N).
 5. Apply the brakes. Turn the key to the ON position. Wait about a second for the contactor to close before continuing.
 6. Move the direction selector to forward or reverse.
 7. Release the park brake.
 8. Check your surroundings and determine your path of travel.
 9. Keeping both hands on the steering wheel, release the brake pedal and gradually push the accelerator toward the floor to begin driving.
 10. Drive slowly. Practice maneuvering and using the accelerator and brakes on level surfaces.
 11. Do not carry a passenger until you have at least two hours of driving experience with this vehicle. Never carry more than one passenger in this vehicle. Never allow a passenger to ride in the cargo box.
 12. To stop the vehicle, release the accelerator pedal completely and brake to a complete stop.
- Tip:** Always come to a complete stop before reversing direction.
13. Set the park brake.
 14. Place the direction selector in neutral.
 15. Turn the key off.

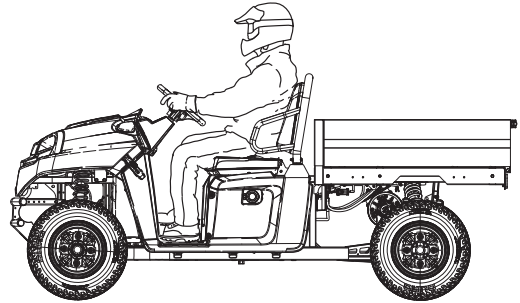

WARNING! A rolling vehicle can cause serious injury. Always set the park brake and remove the key when leaving the vehicle unattended.

OPERATION

Driving On Slippery Surfaces

⚠ WARNING

Skidding or sliding can cause loss of control or rollover (if tires regain traction unexpectedly). When operating on slippery surfaces such as ice or loose gravel, reduce speed and use extra caution to reduce the chance of skidding or sliding out of control. Do not operate on excessively slippery surfaces.

Whenever riding on slippery surfaces such as wet trails or loose gravel, or during freezing weather, follow these precautions:

1. Do not operate on excessively rough, slippery or loose terrain.
2. Slow down before entering slippery areas.
3. Maintain a high level of alertness, reading the trail and avoiding quick, sharp turns, which can cause skids.
4. Engage all-wheel drive before wheels begin to lose traction.
5. Correct a skid by turning the steering wheel in the direction of the skid. *Never apply the brakes during a skid.*

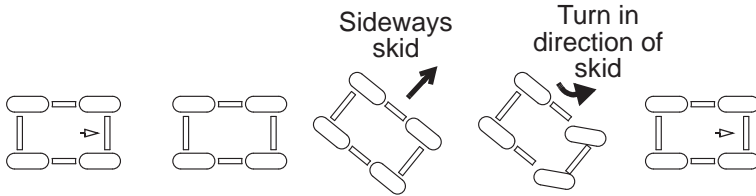

Driving Uphill

Whenever traveling uphill, follow these precautions:

1. Always travel straight uphill.
2. Avoid excessively steep hills.
3. Keep both feet on the floor.
4. Always check the terrain carefully before ascending any hill. Never climb hills with excessively slippery or loose surfaces.
5. Proceed at a steady rate of speed.
6. Never go over the crest of a hill at high speed. An obstacle, a sharp drop, or another vehicle or person could be on the other side of the hill.
7. If the vehicle stalls while climbing a hill, apply the brakes. Place the direction selector switch in reverse and slowly allow the vehicle to roll straight downhill while applying light brake pressure to control speed.

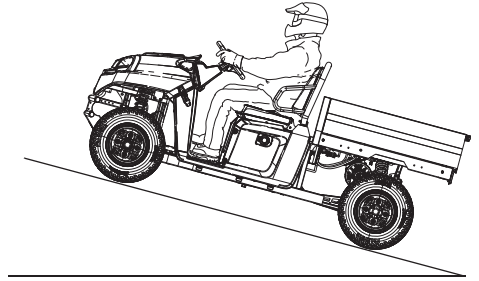

Driving on a Sidehill (Sidehilling)

Driving on a sidehill is not recommended. Improper procedure could cause loss of control or rollover. Avoid crossing the side of any hill unless absolutely necessary.

If crossing a sidehill is *unavoidable*, follow these precautions:

1. Slow down.
2. Exercise extreme caution.
3. Avoid crossing the side of a steep hill.

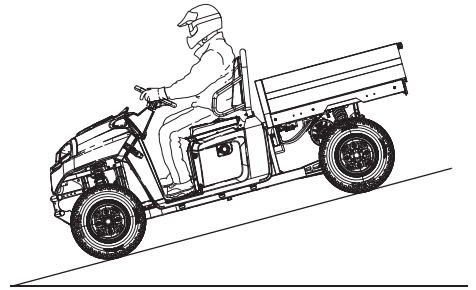

Driving Downhill

When driving downhill, follow these precautions:

1. Avoid excessively steep hills.
2. Always descend a hill with the direction selector switch on forward. Never descend a hill with the switch on neutral.
3. Drive straight downhill. Avoid descending a hill at an angle, which would cause the vehicle to lean sharply to one side. Travel straight downhill when possible.
4. Slow down.
5. Apply the brakes *slightly* to aid in slowing.

OPERATION

Driving in Reverse

Follow these precautions when operating in reverse:

1. Always check for obstacles or people behind the vehicle. Always inspect left and right fields of vision before backing.
2. Always avoid backing downhill.
3. Back slowly.
4. Apply the brakes *lightly* for stopping.
5. Avoid turning at sharp angles.
6. Never accelerate suddenly.

Parking on an Incline

Avoid parking on an incline if possible. If it's unavoidable, follow these precautions:

1. Apply the brakes.
2. Set the park brake.
3. Place the direction selector in neutral.
4. Turn the key off.
5. Block the rear wheels on the downhill side.

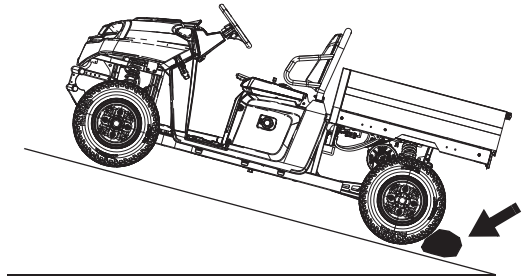

Parking the Vehicle

1. Apply the brakes. Stop the vehicle on a level surface.
2. When parking inside a garage or other structure, be sure that the structure is well ventilated and that the vehicle is not close to any source of flame or sparks, including any appliance with pilot lights.
3. Place the direction selector in neutral.
4. Set the park brake.
5. Turn the key off. Remove the key to prevent unauthorized use.

Hauling Cargo

⚠ WARNING

Hauling cargo improperly can alter vehicle handling and may cause loss of control or brake instability, which can result in serious injury or death. Always follow these precautions when hauling cargo:

Never exceed the maximum weight capacity of the vehicle. When determining the weight you are adding to the vehicle, include the weight of the operator, passenger, accessories, loads in the rack or box and the load on the trailer tongue. The combined weight of these items must not exceed the maximum weight capacity.

REDUCE SPEED AND ALLOW GREATER DISTANCES FOR BRAKING WHEN HAULING CARGO.

Always load the cargo box with the load as far forward and as low as possible.

When operating over rough or hilly terrain, reduce speed and cargo to maintain stable driving conditions.

Always operate the vehicle with extreme care when hauling or towing loads. Reduce speed and avoid abrupt turns when carrying loads that extend over the side of the box.

Slow down and drive in the lowest gear available.

SECURE ALL LOADS BEFORE OPERATING. Unsecured loads can create unstable operating conditions, which could result in loss of control of the vehicle.

OPERATE ONLY WITH STABLE AND SAFELY ARRANGED LOADS. When handling off-centered loads that cannot be centered, securely fasten the load and operate with extra caution. Always attach the tow load to the hitch point designated for your vehicle.

HEAVY LOADS CAN CAUSE BRAKING AND CONTROL PROBLEMS. Use extreme caution when applying brakes with a loaded vehicle. Avoid terrain or situations that may require backing downhill.

USE EXTREME CAUTION when operating with loads that extend over the box sides. Stability and maneuverability may be adversely affected, causing a rollover.

DO NOT TRAVEL FASTER THAN THE RECOMMENDED SPEEDS. Vehicle should never exceed 10 MPH (16 km/h) while towing a load on a level grass surface. Vehicle speed should never exceed 5 MPH (8 km/h) when towing loads in rough terrain, while cornering, or while ascending or descending a hill.

The GEM eM 1400 has been designed to carry or tow specific capacities. Always read and understand the load distribution warnings listed on the warning labels.

The total load (operator, passenger, accessories, cargo and weight on hitch) must not exceed the maximum weight capacity of the vehicle. Never exceed the following capacities.

Model	Maximum Capacities (Level Ground)	Cargo Box
GEM eM 1400	1400 lbs. (635 kg)	1100 lbs. (499 kg)

WARNING! Driving with passengers in the cargo box can result in severe injury or death. Never allow passengers to ride in the cargo box.



OPERATION

Towing Loads

Towing improperly can alter vehicle handling and may cause loss of control or brake instability. Always follow these precautions when towing:

1. Never load more than 150 lbs. (68.1 kg) tongue weight on the towing bracket.
2. Do not operate the vehicle faster than 10 MPH (16 km/h) when towing. See page 31. Towing a trailer increases braking distance.
3. Do not tow more than the recommended weight for the vehicle. See the towing capacity chart below and the specifications charts beginning on page 60.
4. Attach a trailer to the trailer hitch bracket only. Do not attach a trailer to any other location or you may lose control of the vehicle.
5. Never tow a trailer on a grade steeper than 15°.

Model	Total Towed Load Weight (Level Ground)	Total Towed Load Weight (15° grade)	Total Hitch Vertical Weight	Maximum Towing Speed
GEM eM 1400	1250 lbs. (567 kg)	850 lbs. (386 kg)	150 lbs. (68.1 kg)	10 MPH (16 kph)

Towing the Vehicle

NOTICE: When towing the vehicle, the key MUST be in the OFF position or severe motor damage will occur.

Follow these procedures when towing the vehicle:

1. Place the direction selector in neutral.
2. Turn the key off.
3. Always follow these precautions when towing this vehicle:
 - Do not operate faster than 10 MPH (16 km/h).
 - Do not tow on public streets.
 - Do not allow passengers in the towed vehicle.
 - Avoid abrupt starts and stops.
 - Avoid sharp turns and abrupt steering maneuvers.
 - Avoid towing on a hill.

Dumping the Cargo Box

If equipped, use the electric dump box switch to raise the cargo box and dump cargo.

1. Select a level site to dump the cargo box. Do not attempt to dump or unload the vehicle while parked on an incline.
2. Apply the brakes.
3. Set the park brake.
4. Place the direction selector in neutral.
5. Dismount the vehicle.
6. Ensure that the cargo is positioned evenly or toward the front of the cargo box.
7. Stand clear of the dump box. Release the tailgate latches and lower the tailgate.
8. Press and hold the top of the dump box switch to dump the cargo. Release the switch.
9. Press and hold the bottom of the dump box switch to lower the cargo box. Make sure the box is fully seated on the frame before operating the vehicle.
10. Close the tailgate and secure both tailgate latches.

WARNING! Operating the vehicle while the cargo box is raised could result in severe injury. The box could close unexpectedly and cause injury to the driver or passenger. The rear tires will also catch the rear of a raised box, damaging the vehicle and creating hazardous driving conditions. Never operate this vehicle with the cargo box in the raised position.

OPERATION

Transporting the Vehicle

When transporting the GEM eM 1400 for a long distance or on public streets, always use a trailer with an approved load rating greater than the GEM eM 1400's curb vehicle weight of 1700 lbs. (771 kg) plus any installed accessories or cargo.

Follow these guidelines when transporting the GEM eM 1400.

1. Place the direction selector in neutral. Set the park brake.
2. Remove the key to prevent loss.
3. Secure the seat, hood and tailgate latches. Ensure that the seats are attached correctly and are not loose.

WARNING! Cargo and other loose vehicle parts may fly off while transporting this vehicle. Secure or remove all cargo, and inspect the unit for loose parts prior to transport.

4. Always tie the frame of the GEM eM 1400 to the transporting unit securely with suitable straps.
5. If using an open trailer, remove the windshield (if equipped).
6. Never allow passengers on a trailer or in a trailered vehicle.
7. Reduce speed and drive with caution.

These safety warnings and instructions apply if your vehicle came equipped with a winch or if you choose to add an accessory winch to your vehicle.

⚠ WARNING

Improper winch use can result in SEVERE INJURY or DEATH. Always follow all winch instructions and warnings in this manual.

Your winch may have a cable made of either wire rope or specially designed synthetic rope. The term “winch cable” will be used for either unless noted otherwise.

Winch Safety Precautions

1. Read all sections of this manual.
2. Never use alcohol or drugs before or while operating the winch.
3. Never allow children under 16 years of age to operate the winch.
4. Always wear eye protection and heavy gloves when operating the winch.
5. Always keep body, hair, clothing and jewelry clear of the winch cable, fairlead and hook when operating winch.
6. Never attempt to “jerk” a load attached to the winch with a moving vehicle. See the *Shock Loading* section on page 42.
7. Always keep the area around the vehicle, winch, winch cable and load clear of people (especially children) and distractions while operating the winch.
8. Always turn the vehicle ignition power OFF when it and the winch are not being used.
9. Always be sure that at least five (5) full turns of winch cable are wrapped around the winch drum at all times. The friction provided by this wrapped cable allows the drum to pull on the winch cable and move the load.
10. Always apply your vehicle’s park brake and/or park mechanism to hold the vehicle in place during winching. Use wheel chocks if needed.
11. Always align the vehicle and winch with the load directly in front of the vehicle as much as possible. Avoid winching with the winch cable at an angle to the winching vehicle’s centerline whenever possible.
12. If winching at an angle is unavoidable, follow these precautions:
 - A. Look at the winch drum occasionally. Never let the winch cable “stack” or accumulate at one end of the winch drum. Too much winch cable at one end of the winch drum can damage the winch and the winch cable.
 - B. If stacking occurs, stop winching. Follow step 15 on page 40 to feed and rewind the cable evenly before continuing the winch operation.

WINCH GUIDE

Winch Safety Precautions

13. Never winch up or down at sharp angles. This can destabilize the winching vehicle and possibly cause it to move without warning.
14. Never attempt to winch loads that weigh more than the winch's rated capacity.
15. The winch motor may become hot during winch use. If you winch for more than 45 seconds, or if the winch stalls during operation, stop winching and permit the winch to cool down for 10 minutes before using it again.
16. Never touch, push, pull or straddle the winch cable while winching a load.
17. Never let the winch cable run through your hands, even if wearing heavy gloves.
18. Never release the clutch on the winch when the winch cable is under load.
19. Never use the winch for lifting or transporting people.
20. Never use the winch to hoist or suspend a vertical load.
21. Never immerse or submerge your winch in water. Take your winch to your dealer for service if this occurs.
22. Always inspect your winch and winch cable before each use.
23. Never winch the hook fully into the winch. This can cause damage to winch components.
24. Unplug the remote control from the vehicle when the winch is not in use to prevent inadvertent activation and use by unauthorized persons.
25. Never grease or oil the winch cable. This will cause the winch cable to collect debris that will shorten the life of the cable.



Winch Operation

Read the *Winch Safety Precautions* in the preceding pages before using your winch.

Tip: Consider practicing the operation and use of your winch before you actually need to use it in the field.

⚠ WARNING

Improper winch use can result in SEVERE INJURY or DEATH. Always follow all winch instructions and warnings in this manual.

Each winching situation is unique.

- Take your time to think through the winching you are about to do.
 - Proceed slowly and deliberately.
 - Never hurry or rush during winching.
 - Always pay attention to your surroundings.
 - You may need to change your winching strategy if it is not working.
 - Always remember that your winch is very powerful.
 - There are simply some situations that you and your winch will not be able to deal with. Do not be afraid to ask others to help when this happens.
1. Always inspect the vehicle, winch, winch cable and winch controls for any signs of damage or parts in need of repair or replacement before each use. *Pay particular attention to the first 3 feet (1 meter) of winch cable if the winch is being used (or has been used) for lifting an accessory plow assembly.* Promptly replace any worn or damaged cable.
 2. Never operate a winch or a vehicle in need of repair or service.
 3. Always apply your vehicle's park brake and/or park mechanism to hold the vehicle in place during winching. Use wheel chocks if needed.

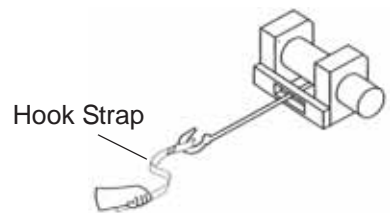

WINCH GUIDE

Winch Operation

4. Always use the hook strap when handling the hook.

WARNING! Never put your fingers into the hook. This could lead to SEVERE INJURY.

- A. Attach the hook itself onto the load or use a tow strap or chain to secure the load to the winch cable.

Tip: A “tow strap” is NOT intended to stretch. A “recovery strap” is designed to stretch.

WARNING! Never use a recovery strap when winching due to the excessive energy that can be released if the winch cable breaks. This can result in SEVERE INJURY or DEATH. See the *Shock Loading* section on page 42.

- B. Never hook the winch cable back onto itself. This will damage the winch cable and may result in winch cable failure.

WARNING! Replace the winch cable at the first sign of damage to prevent SEVERE INJURY or DEATH in the event of failure. For your safety, always replace POLARIS winch parts (including the cable) with genuine POLARIS replacement parts available at your authorized POLARIS dealer.

- C. If possible, keep the winch cable aligned with the centerline of the winching vehicle. This will help the spooling of the winch cable and reduce the load on the fairlead.
 - D. If freeing a stuck vehicle by attaching to a tree, use an item such as a tow strap to avoid damaging the tree during winch operation. Sharp cables and chains can damage and even kill trees. Please remember to TreadLightly® (treadlightly.org).
 - E. Before operating the winch, be sure that the safety latch on the winch cable hook is fully seated when the load is attached.
 - F. Never operate your winch with a damaged hook or latch. Always replace damaged parts before using the winch.
5. Never remove the hook strap from the hook.
6. Release the winch clutch and pull out the winch cable.
7. Pulling out as much cable as possible maximizes the winch’s pulling capacity. Always be sure that at least five (5) full turns of winch cable are wrapped around the winch drum at all times. The friction provided by this wrapped cable allows the drum to pull on the winch cable and move the load.



NO



YES

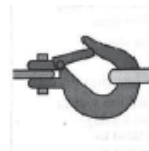

YES



NO

Winch Operation

8. Read and adhere to the following information for winch damping to ensure safe winch use.
 - A. In order to absorb energy that could be released by a winch cable failure, always place a “damper” on the winch cable. A damper can be a heavy jacket, tarp, or other soft, dense object. A damper can absorb much of the energy released if a winch cable breaks when winching. Even a tree limb can help as a damper if no other items are available to you.
 - B. Lay the damper on top of the mid-point of the winch cable length that is spooled out.
 - C. On a long pull, it may be necessary to stop winching so that the damper can be repositioned to the new mid-point of the winch cable. Always release the tension on the winch cable before repositioning the damper.
 - D. Avoid being directly in line with the winch cable whenever possible. Also, never permit others to stand near or in line with the winch cable during winch operation.
9. Never hook the winch cable back onto itself. This will damage the winch cable and may result in winch cable failure.
10. Never use straps, chains or other rigging items that are damaged or worn.
11. The **ONLY** time a winch-equipped vehicle should be moving when using the winch is when that vehicle itself is stuck. The winch-equipped vehicle should **NEVER** be in motion to “shock” load the winch cable in an attempt to move a second stuck vehicle. See the *Shock Loading* section on page 42. For your safety, always follow these guidelines when winching a vehicle free:
 - A. Release the winch clutch and spool out the necessary length of winch cable.
 - B. Align the winch cable as close as possible to the winching vehicle’s centerline.
 - C. Attach the winch cable hook to the anchor point or the stuck vehicle’s frame following instructions in this manual.
 - D. Re-engage the clutch on the winch.
 - E. Slowly winch in the slack in the winch cable.
 - F. Select the proper vehicle gear to propel the stuck vehicle in the direction of winching.
 - G. Shift to the lowest gear available on the stuck vehicle.
 - H. Slowly and carefully apply vehicle throttle and winch together to free the vehicle.
 - I. Stop winching as soon as the stuck vehicle is able to propel itself without the help of the winch.
 - J. Detach the winch cable hook.
 - K. Rewind the winch cable evenly back onto the winch drum following the instructions in this manual.
12. Never attempt to winch another stuck vehicle by attaching the winch cable to a suspension component, brush guard, bumper or cargo rack. Vehicle damage may result. Instead, attach the winch to a strong portion of the vehicle frame or hitch.

WINCH GUIDE

Winch Operation

13. Extensive winching will run down the battery on the winching vehicle. Let the winching vehicle's engine run while operating the winch to prevent the battery from running low if winching for long periods.
14. The winch motor may become hot during winch use. If you winch for more than 45 seconds, or if the winch stalls during operation, stop winching and permit the winch to cool down for 10 minutes before using it again.
15. After winching is complete, especially if winching at an angle, it may be necessary to re-distribute the winch cable across the winch drum. You will need an assistant to perform this task.
 - A. Release the clutch on the winch.
 - B. Feed out the winch cable that is unevenly bunched up in one area.
 - C. Re-engage the winch clutch.
 - D. Have an assistant pull the winch cable tightly with about 100 lbs. (45 kg) of tension using the hook strap.
 - E. Slowly winch the cable in while your assistant moves the end of the winch cable back and forth horizontally to evenly distribute the winch cable on the drum.
 - F. Doing this reduces the chances of the winch cable "wedging" itself between lower layers of winch cable.

Winch Cable Care

For your safety, always replace POLARIS winch parts (including the cable) with genuine POLARIS replacement parts available at your authorized POLARIS dealer.

WARNING! Use of worn or damaged cable could lead to sudden failure and SEVERE INJURY.

1. Always inspect your winch before each use. Inspect for worn or loose parts including mounting hardware. Never use the winch if any part needs repair or replacement.
2. Always inspect your winch cable before each use. Inspect for worn or kinked winch cable.

- A. A kinked winch cable made of wire rope is shown at right. Even after being "straightened out," this cable has already been permanently and severely damaged. Promptly discontinue use of a winch cable in this condition.
- B. A kinked winch cable made of wire rope that has been "straightened out" is shown at right. Even though it may look usable, the cable has been permanently and severely damaged. It can no longer transmit the load that it could prior to kinking. Promptly discontinue use of a winch cable in this condition.
- C. A winch cable made of synthetic rope should be inspected for signs of fraying. Replace the cable if fraying is observed (shown at right). Promptly discontinue use of a winch cable in this condition.
- D. Also replace the winch cable if there are fused or melted fibers. Such an area of the synthetic rope will be stiff and appear smooth or glazed. Promptly discontinue use of a winch cable in this condition.



WINCH GUIDE

Shock Loading

WARNING! Your winch cable is very strong but it is NOT designed for dynamic, or “shock” loading. Shock loading may tension a winch cable beyond its strength and cause the cable to break. The end of a broken winch cable under such high loading can cause SEVERE INJURY or DEATH to you and other bystanders.

Winch cables are designed to NOT absorb energy. This is true of both wire-rope and synthetic-rope winch cables.

1. Never attempt to “jerk” a load with the winch. For example, never take up slack in the winch cable by moving the winching vehicle in an attempt to move an object. This is a dangerous practice. It generates high winch cable loads that may exceed the strength of the cable. Even a slowly moving vehicle can create large shock loads in a winch cable.

WARNING! SEVERE INJURY or DEATH can result from a broken winch cable.

2. Never quickly turn the winch ON and OFF repeatedly (“jogging”). This puts extra load on the winch, winch cable, and generates excessive heat from the motor. This is a form of shock loading.
3. Never tow a vehicle or other object with your winch. Towing an object with a winch produces shock loading of the cable even when towing at slow speeds. Towing from a winch also positions the towing force high on the vehicle. This can cause instability of the vehicle and possibly lead to an accident.
4. Never use recovery straps with your winch. Recovery straps are designed to stretch and can store energy. This stored energy in the recovery strap is released if a winch cable fails making the event even more hazardous. Similarly, never use elastic “bungie” cords for winching.
5. Never use the winch to tie down a vehicle to a trailer or other transportation vehicle. This type of use also causes shock loading that can cause damage to the winch, winch cable, or vehicles used.

Your winch cable is designed and tested to withstand the loads produced by the winch motor when operated from a stationary vehicle. Always remember that the winch and winch cable are NOT designed for shock loading.

Winch Maintenance and Service Safety

WARNING! Improper or lack of winch maintenance and service could lead to SEVERE INJURY or DEATH. Always follow all winch instructions and warnings in this manual.

1. Always inspect your winch before each use. Inspect for worn or kinked winch cable. Also inspect for worn or loose parts including mounting hardware.
2. Permit your winch motor to cool down prior to servicing your winch.
3. Never work on your winch without first disconnecting the battery connections to prevent accidental activation of the winch
4. For your safety, always replace POLARIS winch parts (including the cable) with genuine POLARIS replacement parts available at your authorized POLARIS dealer.
5. Some winch models use wire rope as the winch cable. Other winches use a specially designed synthetic rope as the winch cable.
6. Never replace a synthetic-rope winch cable with a consumer-grade polymer rope such as can be purchased in a hardware store. Although they may look similar, they are NOT alike. A polymer rope not designed for winch use will stretch and store excessive energy when winching.

WARNING! Failure of a stretched rope under winching conditions will release all of the stored energy. This will increase the chances of SEVERE INJURY or DEATH.

MAINTENANCE

Periodic Maintenance Chart

Careful periodic maintenance will help keep your vehicle in the safest, most reliable condition. Inspection, adjustment and lubrication of important components are explained in the periodic maintenance chart.

Inspect, clean, lubricate, adjust and replace parts as necessary. When inspection reveals the need for replacement parts, use genuine GEM parts available from your GEM dealer.

Record maintenance and service in the Maintenance Log beginning on page 66.

Tip: Service and adjustments are important for proper vehicle operation. If you're not familiar with safe service and adjustment procedures, have a qualified dealer perform these operations.

Vehicles subjected to heavy or severe use patterns must be inspected and serviced more frequently.

Severe Use Definition

- Frequent immersion in mud, water or sand
- Racing or race-style high RPM use
- Prolonged low speed, heavy load operation

Maintenance Chart Key

► Perform these operations more often for vehicles subjected to severe use.

D Have an authorized GEM dealer perform these services.

WARNING! Improperly performing the procedures marked with a “**D**” could result in component failure and lead to serious injury or death. Have an authorized GEM dealer perform these services.

MAINTENANCE

Periodic Maintenance Chart

Perform all services at whichever maintenance interval is reached first. Check and lubricate all components at the intervals outlined in the Periodic Maintenance Chart, or more often under severe use, such as wet or dusty conditions. Items not listed in the chart should be lubricated at the general lubrication interval.

Item	Maintenance Interval (whichever comes first)			Remarks
	Hours	Calendar	Miles (Km)	
Steering	-	Pre-Ride	-	Inspect and make adjustments as needed. See Pre-Ride Checklist on page 26.
Front suspension	-		-	
Rear suspension	-		-	
Tires	-		-	
Brake fluid level	-		-	
Brake pedal travel	-		-	
Brake system	-		-	
Wheels/fasteners	-		-	
Frame fasteners	-		-	
Batteries	-		-	
Headlamp/tail lamp	-	Daily	-	Check operation; apply dielectric grease if replacing
▶ D Brake pad wear	10 H	Monthly	-	Inspect periodically
Battery terminals	25 H	Monthly	-	Inspect and clean (page 56)
Battery fluid levels	25 H	Monthly	-	Add as needed (page 56)
Battery terminals	25 H	Monthly	-	Inspect; torque to specification
Transaxle shaft nuts	25 H	Monthly	-	Torque bolts to specification (see service manual)
▶ General lubrication	50 H	3 M	-	Lubricate all fittings, pivots, cables, etc.
D Steering	50 H	6 M	-	Lubricate
▶ Front suspension	50 H	6 M	-	Lubricate
▶ Rear suspension	50 H	6 M	-	Lubricate
▶ Wiring	100 H	12 M	-	Inspect for wear, routing, security; apply dielectric grease to connectors subjected to water, mud, etc.
D Front wheel bearings	100 H	12 M	-	Inspect; replace as needed
D Brake fluid	200 H	24 M	-	Change every two years
D Toe adjustment	-			Inspect periodically; adjust when parts are replaced
D Headlight aim	-			Adjust as needed

- ▶ Perform these procedures more often for vehicles subjected to severe use.
- D Have an authorized GEM dealer perform these services.

MAINTENANCE

Transaxle

Transaxle Specifications Chart

Lubricant	Capacity	Fill Plug Torque	Drain Plug Torque
80W90 API GL5 Gear Lube	13.9 oz. (410 ml)	7.5 ft. lbs. (10 Nm)	7.5 ft. lbs. (10 Nm)

Transaxle Oil Change

This gearbox uses a lifetime fluid. Checking the fluid level and changing the fluid is not required. Please see your authorized GEM dealer for any transaxle-related concerns.

Do NOT add fluid to the transaxle unless changing the fluid. If changing the fluid, add only the recommended fluid capacity as stated in the specifications chart above. Do not check the fluid level after draining and filling.

1. Remove the fill plug.
2. Place a drain pan under the drain plug.
3. Remove the drain plug. Allow the oil to drain completely.
4. Clean the drain plug thoroughly with a dry shop towel.
5. Reinstall the drain plug. Torque to specification.
6. Add only the recommended fluid capacity as stated in the specifications chart above.
7. Reinstall the fill plug. Torque to specification.
8. Check for leaks.
9. Dispose of used oil properly.

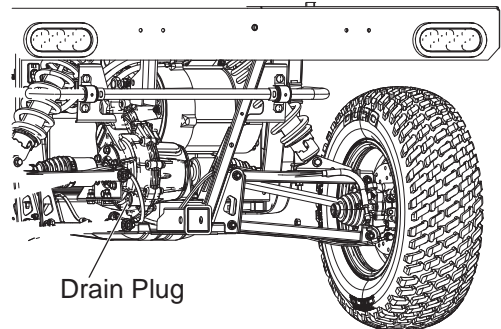
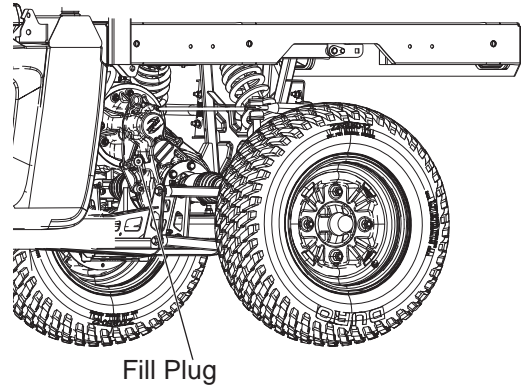

Brakes

The front and rear brakes are hydraulic disc type brakes. Press down on the brake pedal to engage the brakes. See page 25.

Brake Fluid

Inspect the brake system routinely. Inspect the level of the brake fluid before each operation.

WARNING! After opening a bottle of brake fluid, always discard any unused portion. Never store or use a partial bottle. Brake fluid is hygroscopic, meaning it rapidly absorbs moisture from the air. The moisture causes the boiling temperature of the brake fluid to drop, which can lead to early brake fade and the possibility of accident or severe injury.

Change the brake fluid every two years and any time the fluid becomes contaminated, the fluid level is below the minimum, or if the type and brand of the fluid in the reservoir are unknown. Use only DOT 4 brake fluid.

1. Position the vehicle on a level surface.
2. View the brake fluid level at the reservoir in the driver's side wheel well. The level should be between the upper (MAX) and lower (MIN) level lines.
3. If the fluid level is lower than the upper level line, add brake fluid to the upper (MAX) line.
4. Apply the brake forcefully for a few seconds and check for fluid leakage around the fittings.

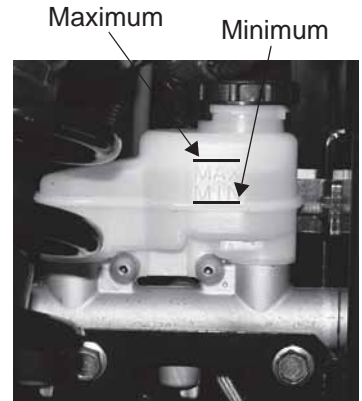

Brake Inspection

1. Check the brake system for fluid leaks.
2. Check the brake pedal for excessive travel or a spongy feel.
3. Check the friction pads for wear, damage and looseness.
4. Check brake discs for signs of cracks, excessive corrosion, warping or other damage. Clean any grease using an approved brake cleaner or alcohol.

WARNING! Do not apply WD-40 or any petroleum product to brake discs. These types of products are flammable and may also reduce the friction between the brake pad and caliper.

5. Inspect the brake disc spline and pad wear surface for excessive wear. Change pads when worn to 3/64" (1 mm).

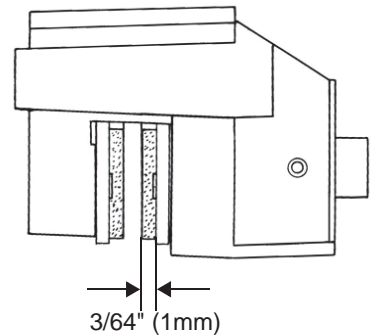

MAINTENANCE

Steering Wheel Inspection

Check the steering wheel for specified freeplay and smooth operation at the intervals outlined in the Periodic Maintenance Chart beginning on page 44.

1. Position the vehicle on a level surface.
2. Lightly turn the steering wheel left and right. There should be 0.8"-1.0" (20-25 mm) of freeplay at the outer rim of the steering wheel.
3. If there is excessive freeplay or strange noises, or the steering feels rough or "catchy," have the steering system inspected by an authorized GEM dealer.

Spring Adjustment

Adjust the rear shock absorber springs by rotating the adjustment cams either clockwise or counter-clockwise to increase or decrease spring tension.

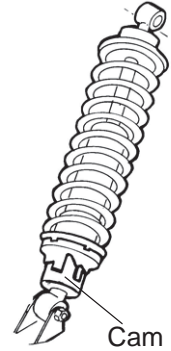

Tires

⚠ WARNING

Operating your vehicle with worn tires, improperly inflated tires, non-standard tires or improperly installed tires will affect vehicle handling and could cause an accident resulting in serious injury or death. Always follow all tire maintenance procedures as outlined in this manual and on the labels on the vehicle. Always use GEM-approved size and type of tires for this vehicle when replacing tires.

Tire Tread Depth

Always replace tires when tread depth is worn to 1/8" (3 mm) or less.

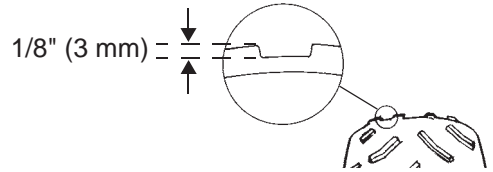

Axle and Wheel Nut Torque Specifications

Inspect the following items occasionally for tightness, and if they've been loosened for maintenance service. Do not lubricate the stud or the lug nut.

Nut Type	Location	Nut Torque
Wheel Nut	Front and Rear	65 ft. lbs. (88 Nm)
Spindle Nut	Front	75 ft. lbs. (102 Nm)
Hub Retaining Nuts	Rear	110 ft. lbs. (150 Nm)

MAINTENANCE

Tires

Wheel Removal

1. Apply the brakes. Set the park brake. Turn the key off.
2. Loosen the wheel nuts slightly.
3. Elevate the side of the vehicle by placing a suitable stand under the frame.
4. Remove the wheel nuts and washers. Remove the wheel.

Wheel Installation

1. Set the park brake. Place the wheel in the correct position on the wheel hub. Be sure the valve stem is toward the outside and rotation arrows on the tire point toward forward rotation.

WARNING! Improperly installed wheels can adversely affect tire wear and vehicle handling, which can result in serious injury or death. Always ensure that all nuts are torqued to specification. Do not service axle nuts that have a cotter pin installed. See your GEM dealer.

2. Attach the wheel nuts and washers and finger tighten.
3. Carefully lower the vehicle to the ground.
4. Torque the wheel nuts to specification.

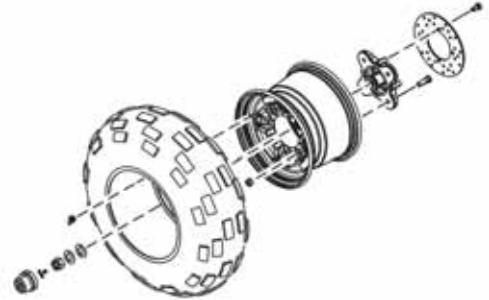

Lights

Poor lighting can result in reduced visibility when driving. Headlight and taillight lenses become dirty during normal operation. Clean lights frequently and replace burned out lamps promptly. Do not operate this vehicle at night or in low light conditions until the headlight is replaced. Always make sure lights are adjusted properly for best visibility.

When servicing a halogen lamp, don't touch the lamp with bare fingers. Oil from your skin leaves a residue, causing a hot spot that will shorten the life of the lamp.

Headlight Lamp Replacement

1. Open the hood.

CAUTION! Hot components can cause burns to skin. Allow lamps to cool before servicing.

2. Unplug the headlamp from the wiring harness. Be sure to pull on the connector, not on the wiring.
3. Turn the lamp counter-clockwise to remove it.
4. Install the new lamp.

Tip: Make sure the tab on the lamp locates properly in the housing.

5. Reinstall the harness assembly into the headlight assembly.

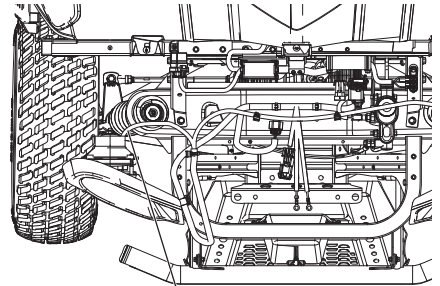

Wiring Harness

Headlight Beam Adjustment

1. Place the vehicle on a level surface with the headlight approximately 25 ft. (7.6 m) from a wall.
2. Measure the distance from the floor to the center of the headlight and make a mark on the wall at the same height.
3. Apply the brakes. Turn the key on. Turn the headlights on.
4. Observe the headlight aim. The most intense part of the headlight beam should be aimed 8" (20 cm) below the mark placed on the wall. Include the weight of a rider on the seat while performing this step.
5. If a headlight needs adjustment, access the adjustment screw under the hood or through the wheel well.
6. Loosen the screw, adjust the headlight, and tighten the screw.
7. Repeat steps 4-6 until the lamp is properly adjusted.

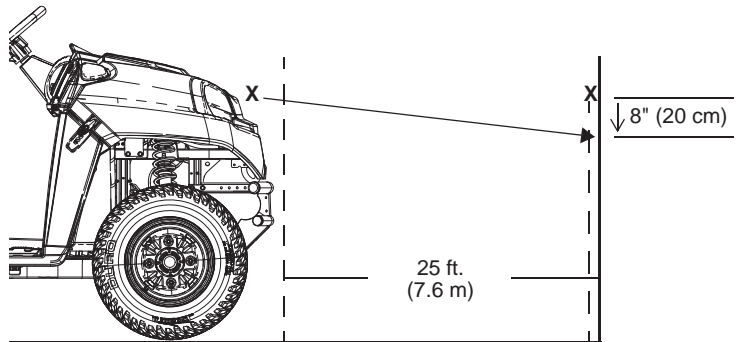

MAINTENANCE

Lights

Brake Lights

When the brake pedal is depressed, the brake light comes on. Check the brake light before each ride.

1. Turn the key to the ON position.
2. Apply the brakes. If the light doesn't come on, check the wiring, the brake switch or the tail light assembly.

Indicator Panel Lamp Replacement

1. Lift the hood.
2. Reach in behind the console panel and lift the release to unplug the light from the harness.
3. Using a flathead screwdriver, press on the tab on the top of the light to remove the indicator light assembly from the console panel.
4. Locate the expired lamp. Using a screwdriver, rotate the lamp 1/4 turn counter-clockwise.
5. Grip the lamp with a needle-nose pliers and remove it from the assembly.
6. Install the new lamp. Using a screwdriver, rotate the lamp 1/4 turn clockwise to seat it.
7. Snap the assembly back into the console panel. Reconnect the harness.
8. Close the hood.

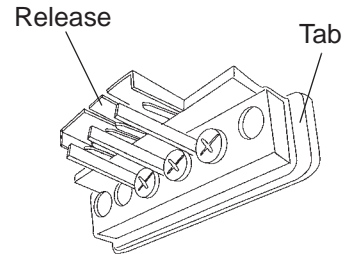

Fuse Replacement

If you experience electrical failure for a specific component (such as indicator lamps or headlights) a fuse may need replacement. Locate and correct any short circuits that may have caused the blown fuse, then replace the fuse.

The fuse box is located under the hood. Spare fuses are provided in the fuse box. If you suspect that a fuse or relay may not be working properly, please see your GEM dealer.

Fuse	Feature Supported
2A	LSV, Indicator Lamps
10A	Lights, Accessories, 12V Power Receptacle
20A	48V Charger, Chassis
25A	14V Charger
30A	48V Fuse Center (under passenger seat)

NOTICE: Always install fuses with the recommended amperage to avoid damage to the electrical system.

Tip: See the label attached to the inside of the fuse access panel for the function and amp rating of each fuse.

Fuse Label

SPARE (48V) 20A	SPARE 2A	SPARE 20A	SWITCHED AUX BATTERY RELAY	CHARGER 48V 20A
	SPARE 10A	SPARE 25A		CHARGER 14V 25A
SPARE (48V) 30A	LSV 2A	INDICATOR 2A		SWITCHED POWER RELAY
	CHASSIS 20A	ACCESSORY 10A		

MAINTENANCE

Batteries

⚠ WARNING

Battery posts, terminals and related components contain lead and lead compounds, chemicals known to cause cancer and reproductive harm. Always wash your hands after touching or handling the batteries.

⚠ WARNING

Charging a damaged battery can result in serious injury. Never attempt to charge a frozen or bulging battery. Discard the battery appropriately and install a new battery.

⚠ WARNING

Improperly connecting or disconnecting battery cables can result in an explosion and cause serious injury or death.

⚠ WARNING

Battery electrolyte is poisonous. It contains sulfuric acid. Serious burns can result from contact with skin, eyes or clothing.

Antidote:

External: Flush with water.

Internal: Drink large quantities of water or milk. Follow with milk of magnesia, beaten egg, or vegetable oil. Call physician immediately.

Eyes: Flush with water for 15 minutes and get prompt medical attention.

Batteries produce explosive gases. Keep sparks, flame, cigarettes, etc. away. Ventilate when charging or using in an enclosed space. Always shield eyes when working near batteries. KEEP OUT OF REACH OF CHILDREN.

Batteries

Battery Charging

When not in use, park the vehicle and connect the battery charger. The battery charge receptacle is located on the left side panel below the driver's seat.

WARNING! Failure to provide adequate ventilation while charging batteries can result in an explosion. Hydrogen gas is emitted during charging and will rise and accumulate at the ceiling. Always ensure a minimum of five (5) air changes per hour in the charging area. Never charge the batteries in an area subject to a flame or spark, including areas containing gas or propane water heaters and furnaces. Do not smoke in the charging area.

Always follow these precautions when charging the batteries:

1. Position the vehicle on a level surface.
2. Make sure the charging area is well ventilated.
3. Make sure the key is off.
4. Remove any vehicle covers and open any door enclosures or zippers.

Tip: If the charger turns off due to an overheated condition (thermal cutback), remove the seat to improve air flow. Reset the charger (interrupt AC power for 15 seconds).

5. Always use an extension cord with a minimum rating of 20 amps.
6. Inspect the charging cord and extension cord for cracks, loose connections and frayed wiring. Replace any damaged components promptly.
7. Always connect the extension cord to the charge receptacle on the vehicle first, then plug the cord into a wall receptacle.
8. Make sure the charger uses a dedicated circuit to prevent overloading. If charging multiple vehicles, each vehicle should use a dedicated circuit.

Tip: After the batteries have fully recharged, the battery charger will automatically cycle in and out of the trickle charge mode to maintain the charge.

9. When disconnecting the charger, always disconnect the extension cord from the wall receptacle first, then disconnect the cord from the vehicle's charge receptacle.

Battery Inspections

Inspect battery terminal connections monthly. Clean batteries as recommended. Using an insulated wrench, torque bolts to 8 ft. lbs. (11 Nm).

Battery Access

To access the batteries, remove the seat. See page 25. Remove the storage tray (if equipped).

NOTICE: Before removing the seat to access the batteries, make sure any wire or metal items (including seat belt latches, if equipped) remain clear of the battery compartment to avoid causing a short circuit to the electrical system.

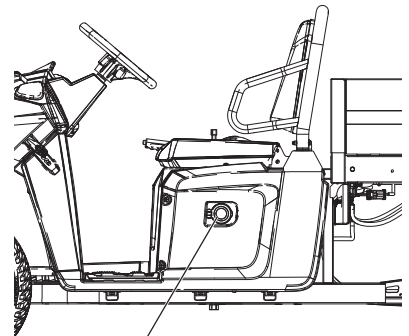

Charge Receptacle

MAINTENANCE

Batteries

Battery Cleaning

Always keep battery terminals and connections free of corrosion. To clean, remove corrosion with a stiff wire brush. Wash with a solution of one tablespoon baking soda and one cup water. Rinse well with tap water and dry off with clean shop towels. Coat battery terminals with dielectric grease or petroleum jelly.

NOTICE: Do not allow cleaning solution or tap water to enter the batteries.

Battery Replacement

With proper care and maintenance as outlined in this owner's manual, battery life could be extended up to four years or longer, depending on the amount of use. When battery replacement is necessary, please see your authorized GEM dealer.

WARNING! Handling batteries and electrical components improperly can result in serious injury or death. Do not attempt to remove batteries or battery cables. Always see your dealer for battery-related service.

Battery Disposal

Lead-acid batteries are recyclable. Return whole scrap batteries to a distributor, manufacturer or lead smelter for recycling. For neutralized spills, place residue in acid-resistant containers with absorbent material, sand or earth and dispose of in accordance with local, state and federal regulations for acid and lead compounds. Contact local and/or state environmental officials regarding disposal information. You can also contact GEM Customer Service for information. See page 1.

Battery Fluid

A poorly maintained battery will deteriorate rapidly. Check the battery fluid level often. *Add only distilled water.* Tap water contains minerals that are harmful to a battery.

Unless the plates are exposed before charging, distilled water should be added to a battery *after* charging. If the plates are exposed, add water to about 1/8 inch (3 mm) above the plates, then charge. Check the fluid level again after charging. Maintain the fluid level 1/4 inch (6 mm) below the bottom of the fill well in the cell cover. Do not overfill.

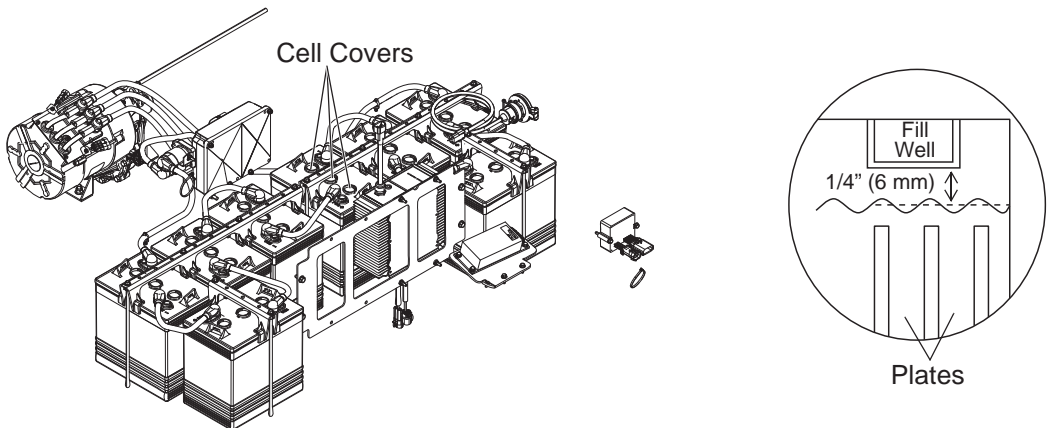

Cleaning and Storage

Washing the Vehicle

Keeping your GEM vehicle clean will not only improve its appearance but it can also extend the life of various components.

NOTICE: High water pressure may damage components. GEM recommends washing the vehicle by hand or with a garden hose, using mild soap.

NOTICE: Certain products, including insect repellents and chemicals, will damage plastic surfaces. Do not allow these types of products to contact the vehicle.

The best and safest way to clean your GEM vehicle is with a garden hose and a pail of mild soap and water.

1. Use a professional-type washing cloth, cleaning the upper body first and the lower parts last.
2. Rinse with clean water frequently.
3. Dry surfaces with a chamois to prevent water spots.

Washing Tips

- Avoid the use of harsh cleaners, which can scratch the finish.
- Do not use a power washer to clean the vehicle.
- Do not use medium to heavy duty compounds on the finish.
- Always use clean cloths and pads for cleaning and polishing. Old or reused cloths and pads may contain dirt particles that will scratch the finish.
- Avoid directing water toward electrical components, including batteries, wiring and switches.

Washing the Vehicle

If a high pressure water system is used for cleaning (not recommended), exercise extreme caution. The water may damage components and could remove paint and labels. Avoid directing the water stream at the following items:

- Wheel bearings
- Transaxle seals
- Brakes
- Cab and body panels
- Labels and decals
- Switches and controls
- Electrical components and wiring

If an informational or graphic label becomes illegible or comes off, contact your GEM dealer to purchase a replacement. Replacement *safety* labels are provided at no charge.

Grease all zerk fittings immediately after washing.

MAINTENANCE

Cleaning and Storage

Polishing the Vehicle

GEM recommends the use of common household aerosol furniture polish for polishing the finish on your GEM vehicle. Follow the instructions on the container.

Polishing Tips

- Avoid the use of automotive products, some of which can scratch the finish of your vehicle.
- Always use clean cloths and pads for cleaning and polishing. Old or reused cloths and pads may contain dirt particles that will scratch the finish.

Storing the Vehicle

Any time the vehicle will be parked for more than a few hours, follow the recommended storage procedures:

1. Make any necessary repairs and clean the vehicle. See page 57.
2. Inspect all cables and lubricate all areas of the vehicle as recommended in the Periodic Maintenance Chart beginning on page 44.
3. Perform battery maintenance. Clean the batteries. See pages 54-56.
4. Inspect the fluid levels. Add or change fluids as recommended in the Periodic Maintenance Chart beginning on page 44.
5. Store the vehicle out of the sun in a cool, dry place.
6. Be sure the storage area is well ventilated.

Tip: Do not use plastic or coated materials to cover the vehicle. They do not allow enough ventilation to prevent condensation, and may promote corrosion and oxidation.

7. Turn the key off.
8. *Do not* set the park brake.
9. Verify that tire pressure is at specification.
10. Block the wheels to prevent rolling.
11. Fully charge the batteries. Leave the charger connected to maintain a full charge during the storage period, or check battery voltage each month during storage and recharge as needed to maintain a full charge. If the charger remains connected, check it monthly to verify proper operation.

WARNING! Do not cover the vehicle while the charger is connected. Dangerous levels of hydrogen gas could accumulate.

Removal from Storage

1. Inspect all battery connections.
2. Verify that batteries are fully charged.
3. Verify that tire pressure is at specification.
4. Perform the pre-ride inspection. See page 26.
5. Inspect and verify the tightness of the bolts, nuts and other fasteners.
6. Lubricate at the intervals outlined in the Periodic Maintenance Chart beginning on page 44.

SPECIFICATIONS

GEM eM 1400	
Dimensions	
Dry Weight	1500 lbs. (680.4 kg)
Ground Clearance	8 in. (20.3 cm)
Length	114.5 in. (291 cm)
Width	56.5 in. (143.5 cm)
Height	52.5 in. (133.3 cm)
Cargo Box (Inside)	51.5 x 41.75 in. (130.8 x 106 cm)
Wheelbase	79 in. (200.7 cm)
Turning Radius (GVW)	Left: 175 in. (444.5 cm) Right: 159 in. (403.9 cm)
Turning Radius (LVW)	Left: 176.2 in. (447.5 cm) Right: 158.6 in. (402.8 cm)
Load Capacity	
Cargo Box Capacity	1100 lbs. (499 kg)
Payload Capacity	1400 lbs. (635 kg)
Hitch Towing Capacity	1250 lbs. (567 kg)
Cargo System	Lock & Ride®
Seating	2
Performance	
Motor configuration	Single, 48-volt, high efficiency, AC induction motor
Motor rating HP	7.5 HP continuous
Controller	450 - Amp Sevcon Gen IV controller with regenerative
Battery pack	10.4 kw battery pack at 48V DC with 8 6-volt, US12VXC batteries in series-parallel configuration
Maximum speed	19 MPH (30.5 km/h)
Range (on flat ground)	45 miles (72 km) (may vary with driving conditions)
Throttle	Redundant, non-contact, inductive-sensing pedal
On-board charger	Delta Q 120-volt AC input; 48-volt DC output
Charge time	8 hours (dependent on depth of discharge)
Drivetrain	
Transaxle	Direct drive motor-to-transaxle with low-noise gears
Drive	Turf-friendly rear wheel drive

SPECIFICATIONS

GEM eM 1400	
Brake System	
Brakes	4-Wheel hydraulic disc w/dual bore front calipers
Park Brake	Lever-activated mechanical park brake
Suspension	
Front suspension	Independent Macpherson struts w/5 in. (12.5 cm) travel
Rear suspension	Dual A-Arm w/6 in. (15 cm) travel
Tire size	23x8.5-12
Tire pressure	32 psi (220 kPa)
Features	
Cup holders	Dual cup holders
Indicator panel	Indicates directional selection, park brake, and motor or controller malfunction
Charge indicator	Digital, indicates battery discharge
Hour meter	Digital, indicates cumulative hours of use
Auxiliary power	12-volt accessory outlet
Rider restraints	None
Headlights/taillights	Dual 55-watt
Brake lights	LED 1.8 watts at 12 volts
Storage	Glove box

TROUBLESHOOTING

Vehicle Will Not Operate

Possible Cause	Solution
Low battery voltage	Recharge the battery overnight
Loose battery connections	Check all connections and tighten
Loose contactor connections	Check all connections and tighten
Loose electronic control box connections	Inspect, clean, reinstall connectors
Required torque exceeds motor capability	In neutral, cycle key off and on, select low range, then select direction

WARRANTY

LIMITED WARRANTY

POLARIS Sales Inc., 2100 Highway 55, Medina, MN 55340, gives a TWO-YEAR, 8,000-MILE (12,900-km) or 750-HOUR, whichever comes first, LIMITED WARRANTY on all components (except batteries) of your GEM vehicle against defects in material or workmanship. Mileage is unlimited for the first 6 months of the vehicle warranty. Any time after month 6, the vehicle warranty expires at 8,000 miles (12,900 km), at 750 hours or at the end of the two-year period, whichever comes first. This warranty covers the parts and labor charges for repair or replacement of defective parts and begins on the date of purchase by the original retail purchaser. This warranty is transferable to another consumer during the warranty period through a GEM dealer, but any such transfer will not extend the original term of either warranty. The duration of this warranty and/or the battery warranty may vary by international region based upon local laws and regulations.

BATTERY COVERAGE

Battery coverage in this Limited Warranty begins on the date of purchase by the original retail purchaser and continues for twenty-four months, 8,000 miles (12,900 km) or 750 hours, whichever comes first. Mileage is unlimited for the first 6 months of the battery warranty. Any time after month 6, the battery warranty expires at 8,000 miles (12,900 km), at 750 hours or at the end of the two-year period, whichever comes first. During this time period, POLARIS warrants your vehicle's batteries against defects in materials or workmanship. After the first six months in service, a defective battery will be replaced on a manufacturer/customer shared basis provided that the warranty limit of 8,000 miles (12,900 km) or 750 hours has not yet occurred. Review the following table for guidelines.

BATTERY COVERAGE

TERM FOR VEHICLES WITH LESS THAN 8,000 MILES (12,900 km) OR 750 HOURS	WARRANTY COVERAGE FOR BATTERIES DEEMED DEFECTIVE BY GEM
Purchase Date - 6th Month of Service	100% of the cost of an approved GEM battery at a GEM dealer
7th - 12th Month of Service	75% of the cost of an approved GEM battery at a GEM dealer
13th - 18th Month of Service	50% of the cost of an approved GEM battery at a GEM dealer
19th - 24th Month of Service	25% of the cost of an approved GEM battery at a GEM dealer

REGISTRATION

At the time of sale, the Warranty Registration Form must be completed by your dealer and submitted to GEM within three days. Upon receipt of this registration, GEM will record the registration for warranty. No verification of registration will be sent to the purchaser as the copy of the Warranty Registration Form will be the warranty entitlement. If you have not signed the original registration and received the customer copy, please contact your dealer immediately. **NO WARRANTY COVERAGE WILL BE ALLOWED UNLESS YOUR VEHICLE IS REGISTERED WITH GEM.** Initial dealer preparation and set-up of your vehicle is very important in ensuring trouble-free operation. Purchasing a machine in the crate or without proper dealer set-up will void your warranty coverage.

LIMITATIONS OF WARRANTIES AND REMEDIES

This POLARIS limited warranty excludes any failures that are not caused by a defect in material or workmanship. **THIS WARRANTY DOES NOT COVER CLAIMS OF DEFECTIVE DESIGN.** This warranty also does not cover acts of God, accidental damage, normal wear and tear, abuse or improper handling. This warranty also does not cover any vehicle, component, or part that has been altered structurally, modified, neglected, improperly maintained, or used for purposes other than for which it was designed, or for any damages which occur during trailer transit or as a result of unauthorized service or the use of unauthorized parts.

This warranty excludes damages or failures resulting from: improper lubrication; corrosion, surface imperfections caused by external stress, heat, cold or contamination; operator error or abuse; improper component alignment, tension, adjustment or altitude compensation; snow, water, dirt or other foreign substance contamination; improper maintenance; modified components; use of aftermarket or unapproved components, accessories, or attachments; unauthorized repairs; or repairs made after the warranty period expires or by an unauthorized repair center.

This warranty excludes damages or failures caused by abuse, accident, fire, explosion, or any other cause other than a defect in materials or workmanship and provides no coverage for consumable components, general wear items, or any parts exposed to friction surfaces, stresses, environmental conditions and/or contamination for which they were not designed or not intended, including but not limited to the following items:

- Wheels and tires
- Suspension components
- Brake components
- Seat components
- Clutches and components
- Steering components
- Batteries
- Light bulbs/Sealed beam lamps
- Painted or otherwise finished surfaces
- Upholstery
- Engine components
- Drive belts
- Hydraulic components and fluids
- Circuit breakers/Fuses
- Electronic components

The battery coverage included in this warranty provides no coverage for:

- Batteries that fail due to lack of battery maintenance, over-charging, under-charging, abuse or neglect
- Batteries that fail due to fire, wreckage, explosion, or freezing
- Broken batteries
- Batteries damaged by defective chargers
- Batteries to which an additive is added
- Batteries which have been improperly stored and allowed to discharge
- Any battery pack with a mixture of code dates or with other manufacturer's products
- Any battery improperly installed or with loose or corroded hardware

This warranty provides no coverage for personal loss or expense, including mileage, transportation costs, hotels, meals, shipping or handling fees, product pick-up or delivery, replacement rentals, loss of product use, loss of profits, or loss of vacation or personal time.

WARRANTY

LIMITATIONS OF WARRANTIES AND REMEDIES

The exclusive remedy for breach of this warranty shall be, at POLARIS' sole option, repair or replacement of any defective materials, or components or products. **THE REMEDIES SET FORTH IN THIS WARRANTY ARE THE ONLY REMEDIES AVAILABLE TO ANY PERSON FOR BREACH OF THIS WARRANTY. POLARIS SHALL HAVE NO LIABILITY TO ANY PERSON FOR INCIDENTAL, CONSEQUENTIAL OR SPECIAL DAMAGES OF ANY DESCRIPTION, WHETHER ARISING OUT OF EXPRESS OR IMPLIED WARRANTY OR ANY OTHER CONTRACT, NEGLIGENCE, OTHER TORT OR OTHERWISE. THIS EXCLUSION OF CONSEQUENTIAL, INCIDENTAL, AND SPECIAL DAMAGES IS INDEPENDENT FROM AND SHALL SURVIVE ANY FINDING THAT THE EXCLUSIVE REMEDY FAILED OF ITS ESSENTIAL PURPOSE.**

THE IMPLIED WARRANTY OF FITNESS FOR A PARTICULAR PURPOSE IS EXCLUDED FROM THIS LIMITED WARRANTY. ALL OTHER IMPLIED WARRANTIES (INCLUDING BUT NOT LIMITED TO THE IMPLIED WARRANTY OF MERCHANTABILITY) ARE LIMITED IN DURATION TO THE ABOVE 2-YEAR, 8,000-MILE OR 750-HOUR WARRANTY PERIOD. POLARIS DISCLAIMS ALL EXPRESS WARRANTIES NOT INCLUDED IN THIS WARRANTY STATEMENT. SOME STATES DO NOT PERMIT THE EXCLUSION OR LIMITATION OF INCIDENTAL OR CONSEQUENTIAL DAMAGES OR ALLOW LIMITATIONS ON THE DURATION OF IMPLIED WARRANTIES, SO THE ABOVE LIMITATIONS OR EXCLUSIONS MAY NOT APPLY TO YOU IF INCONSISTENT WITH CONTROLLING STATE LAW.

HOW TO OBTAIN WARRANTY SERVICE

If your vehicle requires warranty service, you must take it to a GEM Servicing Dealer. When requesting warranty service you must present your copy of the Warranty Registration Form to the dealer. (THE COST OF TRANSPORTATION TO AND FROM THE DEALER IS YOUR RESPONSIBILITY). POLARIS suggests that you use your original selling dealer; however, you may use any GEM Servicing Dealer to perform warranty service.

In the country where your product was purchased:

Warranty or Service Bulletin repairs must be done by an authorized GEM dealer. If you move or are traveling within the country where your product was purchased, Warranty and Service Bulletin repairs may be requested from any authorized GEM dealer that sells the same line as your product.

Outside the country where your product was purchased:

If you are traveling temporarily outside the country where your product was purchased, you should take your product to an authorized GEM dealer. You must show the dealer photo identification from the country of the selling dealer's authorized location as proof of residence. Upon residence verification, the servicing dealer will be authorized to perform the warranty repair.

If you move:

If you move to another country, be sure to contact POLARIS Customer Assistance and the customs department of the destination country before you move. Product importation rules vary considerably from country to country. You may be required to present documentation of your move to POLARIS in order to continue your warranty coverage. You may also be required to obtain documentation from POLARIS in order to register your product in your new country. You should warranty register your product at a local GEM dealer in your new country immediately after you move to continue your warranty coverage and to ensure that you receive information and notices regarding your vehicle.

If you purchase from a private party:

If you purchase a GEM vehicle from a private party, to be kept and used outside of the country in which the product was originally purchased, all warranty coverage will be denied. You must nonetheless register your product under your name and address with a local GEM dealer in your country to ensure that you receive safety information and notices regarding your product.

Exported Products

EXCEPT WHERE SPECIFICALLY REQUIRED BY LAW, THERE IS NO WARRANTY OR SERVICE BULLETIN COVERAGE ON THIS PRODUCT IF IT IS SOLD OUTSIDE THE COUNTRY OF THE SELLING DEALER'S AUTHORIZED LOCATION. This policy does not apply to products that have received authorization for export from POLARIS. Dealers may not give authorization for export. You should consult an authorized dealer to determine this product's warranty or service coverage if you have any questions. This policy does not apply to products registered to government officials or military personnel on assignment outside the country of the selling dealer's authorized location. This policy does not apply to Safety Bulletins.

Notice

If your product is registered outside of the country where it was purchased and you have not followed the procedure set above, your product will no longer be eligible for warranty or service bulletin coverage of any kind, other than safety bulletins. Products registered to Government officials or military personnel on assignment outside of the country where the product was purchased will continue to be covered by the Limited Warranty.

Please work with your dealer to resolve any warranty issues. Should your dealer require any additional assistance, they will contact the appropriate person at POLARIS.

This warranty gives you specific legal rights, and you may also have other rights which vary from state to state or in different countries. If any of the above terms are void because of federal, state, local law, all other warranty terms will remain in effect.

GEM Customer Service

Phone: 855-RIDEGEM (855-743-3436)

Web: www.gemcar.com

MAINTENANCE LOG

Use the following chart to record periodic maintenance.

DATE	MILES (KM) OR HOURS	TECHNICIAN	SERVICE PERFORMED / COMMENTS

MAINTENANCE LOG

DATE	MILES (KM) OR HOURS	TECHNICIAN	SERVICE PERFORMED / COMMENTS

INDEX

A

Accelerator Pedal	25
Auxiliary 12-Volt Terminal Board	18
Auxiliary Outlets	18
Axle Nut Torque	49

B

Batteries

Accessing	55
Ambient Temperature Implications	23
Charge Status Indicator	19, 21
Charger Operation	23
Charging	55
Charging Cord	23
Cleaning	56
Conditioning	23
Discharge Indicator	18
Disposal	56
Fluid	56
Handling Precautions	22
Inspections	55
Main Power Connector	24
Operation Range	23
Replacement	56
Brake Lever, Park	19
Brake Lights	52
Brake Pedal	25
Brakes	47
Brake Fluid	47
Brake Inspection	47

C

Cargo	31
Cargo Box, Dumping	33
Charge Status Indicator	19, 21
Charger Operation	23
Charging Batteries	55
Cleaning and Storage	57-58
Component Locations	16
Console	17-20
Contact Us	1, 65
Customer Service	1, 65

D

Direction Selector	18
Discharge Indicator	18
Driving Downhill	29
Driving in Reverse	30
Driving on a Sidehill	29
Driving on Slippery Surfaces	28
Driving Procedure	27
Driving Uphill	29
Dumping the Cargo Box	33

E

Equipment Modifications	12
Eye Protection	10

F

Fluid, Battery	56
Fluid, Brake	47
Fuse Replacement	53

G

Gross Vehicle Weight Rating	12
GVWR	12

H

Hard Hat/Helmet	10
Hauling Cargo	31
Headlight Beam Adjustment	51
Headlight Lamp Replacement	51
Headlight Switch	18
Hitch Bracket	25
Hitch Weight	32
Hour Meter	18

I

Indicator Lights	20
Indicator Panel Lamp Replacement	52
Indicator, Charge Status	19

K

Key Switch	19
Key, Periodic Maintenance Chart	44

L

Lamp Replacement, Indicator Panel	52
---	----

Lights

Brake Lights	52
Headlight Beam Adjustment	51
Headlight Lamp Replacement	51
Indicator Lamp Replacement	52
Indicator Lights	20

M

Main Power Connector	24
Maintenance Log	66
Maintenance Precautions	15
Maintenance, Periodic	44-45
Malfunction Indicator	21
Modifications	12

O

Operation Range	23
Operator Safety	10-15

P

Park Brake Lever	19
Parking on an Incline	30
Parking the Vehicle	30
Periodic Maintenance Chart	44-45
Personal Protective Equipment	10
Polishing the Vehicle	58
Pre-Ride Inspection	26
Pressure, Tire	7

R

Range of Operation	23
Removing the Vehicle from Storage	59
Reverse Operaton	30

S

Safety Gear	10
Safety Glasses	10
Safety Labels	7-9
Safety Shoes	10
Safety Symbols	4
Safety, Winch Maintenance	43
Seat Removal	25
Severe Use Definition	44
Shock Loading the Winch	42
Shock Spring Adjustment	48
Signal Words	4
Speed, Towing	32
Steering Wheel Inspection	48
Storage	57-58
Storage, Removal	59
Storing the Vehicle	59

Switches

Direction Selector	18
Headlight Switch	18
Key Switch	19

T

Tire Pressure	7
Tires	49-50
Nut Torque	49
Tread Depth	49
Wheel Installation	50
Wheel Removal	50
Towing Loads	32
Towing Speed	32
Towing the Vehicle	32
Trailer Hitch Bracket	25
Transaxle Oil	46
Transporting the Vehicle	34
Troubleshooting	
Charge Status Indicator	21
Malfunction Indicator	21
Vehicle Will Not Operate	61

V

Vehicle Identification Numbers	6
Vehicle Range	23
Vehicle Will Not Operate	61

W

Warning Symbols	4
Washing the Vehicle	57
Weight Capacity	12
Weight, Hitch	32
Wheel Installation	50
Wheel Nut Torque	49
Wheel Removal	50
Winch Cable Care	41
Winch Maintenance and Service Safety	43
Winch Operation	37-40
Winch Safety Precautions	35-36
Winch Shock Loading	42

WARNING

Improper vehicle use can result in SEVERE INJURY or DEATH

NEVER Operate:

- If you are under age 16 and without a valid driver's license.
- At speeds too fast for your skills or the conditions.
- On extreme off-road terrain or extreme slopes.
- On public roads (unless designated for off-road use).
- With more than one passenger, or a passenger under age 12 or who cannot comfortably reach the floor and hand holds.
- On paved surfaces - pavement may seriously affect handling and control.
- With non-GEM approved accessories - they may seriously affect stability.

ALWAYS:

- Wear your seat belt, if equipped. Vehicle rollover can cause severe injury or death.
- Keep hands and feet inside vehicle at all times.
- Wear a hard hat or helmet, approved eye protection, substantial footwear, long pants and a close-fitting shirt.
- Reduce speed and use extra caution when carrying a passenger.
- Avoid sharp turns or turns while applying heavy throttle.
- Operate slowly in reverse - avoid sharp turns or sudden braking.
- Make sure passenger reads and understands all safety labels.
- Watch for branches and other hazards that could enter vehicle.



**ALL RIDERS MUST WEAR APPROVED PROTECTIVE GEAR.
NEVER USE ON PUBLIC ROADS. NEVER USE WITH DRUGS OR ALCOHOL.
READ OWNER'S MANUAL. FOLLOW ALL INSTRUCTIONS AND WARNINGS.**



For your nearest GEM dealer,
call 855-RIDEGEM (855-743-3436)
or visit www.gemcar.com
Polaris Sales Inc.
2100 Hwy. 55
Medina, MN 55340

Part No. 9924949 Rev 02
Printed in USA

