

# PHOENIX GOLD®



## AMPLIFIER MANUAL MANUAL DEL AMPLIFICADOR MANUEL DEL'AMPLIFICATEUR

**Model: SD800.4, SD1100.5**

### Features:

- Compact Size for Easy Installation
- High Efficiency Class D Topology
- High and Low Pass Crossovers
- ADAPT Power Management System
- Surface Mount Component Technology
- Direct Insert Power and Speaker Terminals
- Audio Precision Quality Control Verification
- High Temperature Plexiglass cover
- RMD - Remote Monitoring Display Port
- RBCF - Remote subwoofer level control included (SD1100.5)

### Características:

- Tamaño compacto para fácil instalación
- Alta eficiencia de clase D Topología
- Crossovers paso alto y bajo
- ADAPT Sistema de Gestión de Energía
- Tecnología "Surface Mount Component"
- Conexiones directas de terminales de poder y de parlantes
- Control de verificación de calidad de precisión de audio
- Cubierta de Plexiglas resistente a altas temperaturas
- RMD - Puerto de display para monitoreo remoto
- RBCF - Control de nivel de Subwoofer remoto incluido (SD1100.5)

### Caractéristiques:

- Topologie de classe D de gamme complète
- Petit format pour faciliter l'installation
- Filtres croisés passe-haut et passe-bas
- ADAPT système d'alimentation
- Technologie de composant monté en surface
- Terminaux d'alimentation et de haut-parleurs à insertion directe
- Vérification du contrôle de la qualité de la précision audio
- Couvercle de plexiglas résistant aux températures élevées
- RMD - Entrée De L'affichage de Tension a Distance
- RBCF - Niveau de contrôle de passe-bas inclus (SD1100.5)

## SPECIFICATIONS

### SD800.4 SPECIFICATIONS

Frequency Response:	± 1dB from 20Hz to 20kHz	RMS Power Output	125w x 4 @ 4 ohms Stereo
Signal to Noise Ratio:	>100dB		200w x 4 @ 2 ohms Stereo
High and Low Pass Crossovers:	12dB per Octave		400w x 2 @ 4 ohms Bridged
Crossover Range:	40Hz to 400Hz	Power/Ground Wire Size:	4 Gauge
Bass Boost @ 45Hz:	0 to +18dB	Recommend Power Wire Fuse:	60a
Low Level Input Range:	200 millivolts to 8 volts	Dimensions (Includes Mounting Feet):	11.0" L x 6.9" W x 2.0" H
Lowest Recommend Load:	4 ohms Bridged/2 ohms Stereo		279mm L x 176mm W x 51mm H
Typical Efficiency:	80%	Dimensions (Includes Terminals):	11.6" L x 6.9" W x 2.0" H
Damping Factor	Greater than 200		295mm L x 176mm W x 51mm H

### SD1100.5 SPECIFICATIONS

FRONT AND REAR CHANNELS:			
Frequency Response:	± 1dB from 20Hz to 20kHz	RMS Power Output	125w x 4 @ 4 ohms Stereo
Signal to Noise Ratio:	>100dB		200w x 4 @ 2 ohms Stereo
High and Low Pass Crossovers:	12dB per Octave		400w x 2 @ 4 ohms Bridged
Front/Rear High Pass Crossover Range:	15Hz to 250Hz		
Low Level Input Range:	200 millivolts to 8 volts		
Lowest Recommend Load:	4 ohms Bridged/2 ohms Stereo		
Typical Efficiency:	80%		
Damping Factor	Greater than 200		

SUBWOOFER CHANNEL:			
Frequency Response:	± 1dB from 20Hz to 300Hz	RMS Power Output	200w x 1 @ 4 ohms
Signal to Noise Ratio:	>100dB		300w x 1 @ 2 ohms
Low Pass Crossover:	12dB per Octave	Recommend Power Wire Fuse:	80a
Low Pass Crossover Range:	30Hz to 300Hz	Power/Ground Wire Size:	4 Gauge
Bass Boost @ 45Hz:	0 to +18dB	Dimensions (Includes Mounting Feet):	12.2" L x 6.9" W x 2.0" H
Low Level Input Range:	200 millivolts to 8 volts		309mm L x 176mm W x 51mm H
Lowest Recommend Load:	2 ohms	Dimensions (Includes Terminals):	12.8" L x 6.9" W x 2.0" H
Typical Efficiency:	80%		325mm L x 176mm W x 51mm H
Damping Factor:	Greater than 200		

POWER OUTPUT NOTE: A power birth certificate is included for each amplifier. SD amplifiers are conservatively rated and will exceed their RMS power rating shown here. All RMS power ratings and measurements are at 14.4 volts with no more than 1% THD. SD800.4 and SD1100.5 feature ADAPT technology which provides the same power output from 11 to 15 volts with music material.

## KEY FEATURES

- A BALANCED DIFFERENTIAL INPUTS**  
Provides maximum rejection of unwanted noise from upstream components.
- B AUDIOPHILE NJM2068M OP-AMPS**  
Most mobile amplifiers today use the standard NJM4558 op-amp which has a bandwidth of 3MHz, slew rate of 1V/uSec and noise level of 1.4uV. The NJM2068M is simply a better performer with a bandwidth of 19MHz, slew rate of 6V/uSec and noise level of .44uV.
- The result is quieter, faster and wider bandwidth performance that ensures the original music material is reproduced as accurately as possible.
- C ULTRA HIGH SPEED IR CLASS D CHIPSET**  
State of the art IR20957 chipset switches at more than 300kHz for blistering audio performance. All four or five chipsets are sync'd together in unison to eliminate unwanted harmonics or distortion.
- D POST FILTER FEEDBACK**  
Feedback is when part of the output signal is "fed back" into the original signal to ensure stability and accurate sound. Class D amplifiers use output filters (see the 4 vertical coils below), but most DO NOT INCLUDE these filters in the feedback loop. SD amplifiers INCLUDE or take feedback after its passed through these filters. The result is more accurate sound that rivals some of the best class A/B amplifiers.

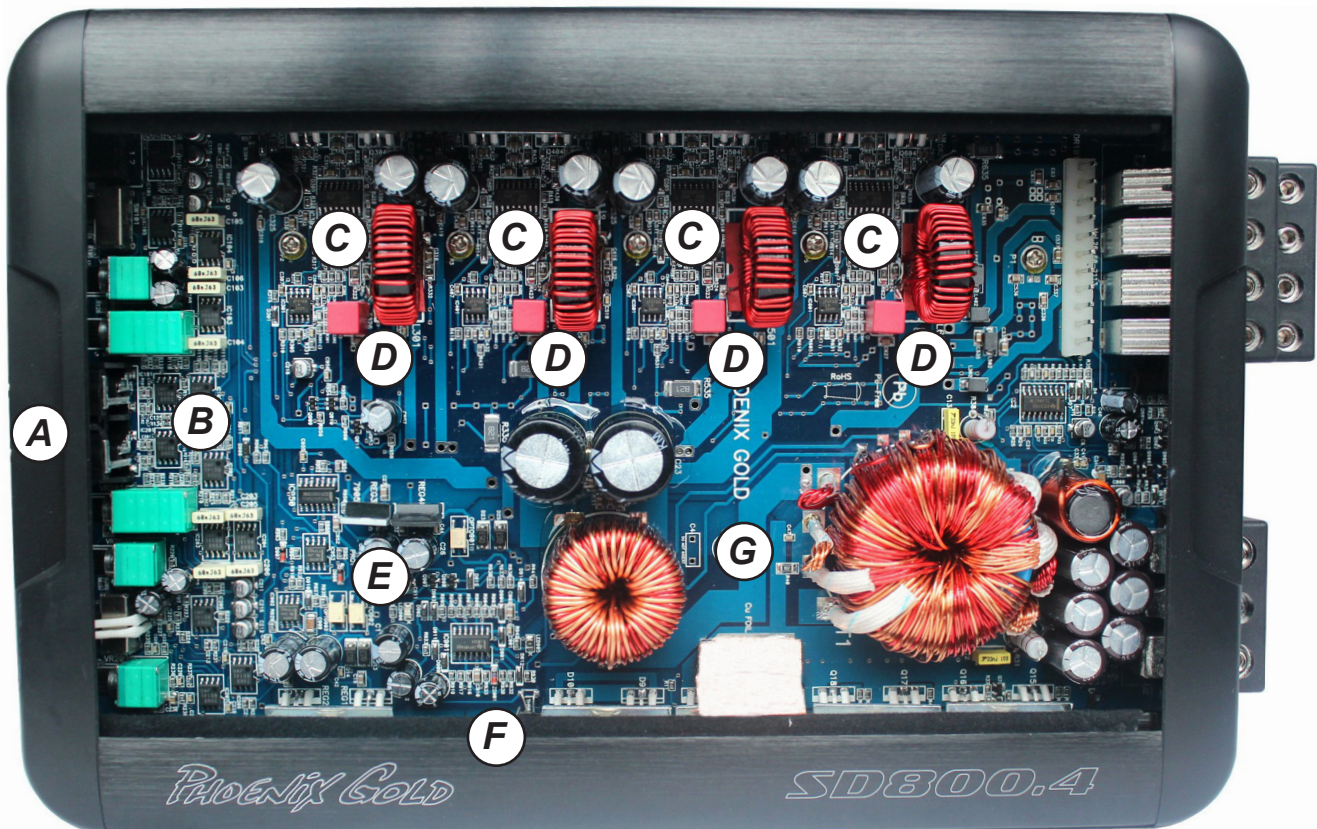

- E ADAPT POWER MANAGEMENT SYSTEM**  
**Full power output from 11 to 15 volts:** ADAPT delivers the same output power regardless of the vehicle's electrical system voltage. Instantaneous or long term voltage drops have no effect on the amplifier's power output. This means more dynamic and less distorted audio output.
- Dual power modes provide maximum efficiency:** ADAPT seamlessly optimizes the power supply and Class D operating circuitry by adapting to the end user's listening habits. When the ADAPT circuit senses lower signal levels, it will automatically optimize the amplifier's power supply and Class D circuitry to a low power mode that maximizes efficiency and minimizes heat to almost zero. As a signal increase is detected the amplifier instantly shifts into a high power mode, where the power supply and Class D sections are now optimized to deliver massive power and headroom for those demanding listening sessions. The amplifier is constantly monitoring and adapting between these modes which results in higher overall efficiency, much lower operating temperatures and rock solid reliability.
- F THERMAL ROLLBACK CIRCUIT**  
Under most conditions, SD amplifiers generate moderate to low heat. However, if extreme conditions exist, as temperatures rise the amplifier will automatically adjust the power output, so your music continues to play. These changes are inaudible and vastly reduce the chance for any thermal shutdown events.
- G LOW EMI CIRCUIT BOARD DESIGN**  
Most class D amplifiers can emit EMI noise that can cause problems with AM/FM reception or other devices in the vehicle. SD amplifiers have undergone intense real world engineering and testing to vastly reduce or eliminate these issues. Careful PCB layout using four layers (most amplifiers feature just two) along with many key filters ensures a very low possibility of any interference issues.

## **SD800.4** **4 CHANNEL POWER AMPLIFIER**

### **FRONT AND REAR INPUTS**

Connect preamp signal cables from headunit to these inputs. The front AND rear inputs must be used, if only the front input is used then the rear speaker outputs will have no output signal.

### **CROSSOVER FREQUENCY**

Controls the crossover point for the speaker outputs.

### **BASS BOOST**

Variable bass boost from 0 to +18dB @ 45Hz.

### **SENS**

Used to reach maximum amplifier power with a wide variety of headunits.

### **CONFIG**

FLAT: Crossovers are turned off

HP: High pass crossover is on

LP: Low pass crossover is on

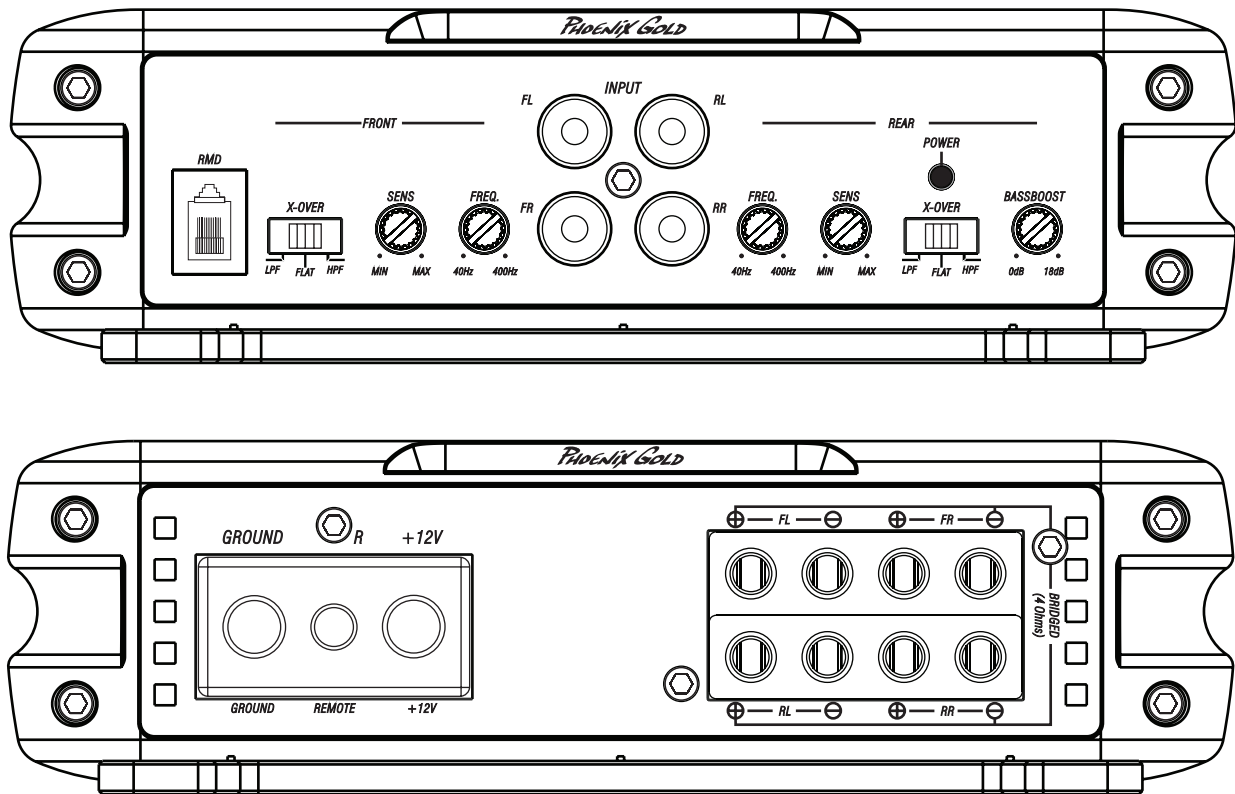

### **+12V**

This must be connected to the fused positive terminal (+12V) of the car's battery. The fuse must be located within 18 inches of the battery.

### **REMOTE**

This must be connected to switched +12V, usually a trigger wire coming from the head unit or ignition.

### **GROUND**

This must be connected to the negative terminal of the car's battery or bolted to a clean, unpainted part of the chassis of the vehicle.

### **REMOTE MONITORING DISPLAY (RMD)**

Connect optional RMD Voltage Display to this port.

### **SPEAKER OUTPUTS**

Used to connect the amplifier to speakers. SD800.4's minimum impedance is 4 ohms bridged or 2 ohms stereo. Use the Left + and Right - to bridge the channels.



**SD1100.5  
5 CHANNEL POWER AMPLIFIER**

**FRONT, REAR AND SUB INPUTS**

Connect preamp signal cables from headunit to these inputs.

**SUB INPUT SWITCH**

Determines which input will feed signal to the subwoofer channel.

"IN" or SUB = Use the Sub Input

"OUT" or F/R = Use the Front and Rear inputs as its signal will be summed then sent to the sub channel of the amplifier.

**HPF/LPF CROSSOVER FREQUENCY**

Controls the crossover point for the speaker outputs.

**SENS**

Used to reach maximum amplifier power with a wide variety of headunits.

**BASS BOOST**

Variable bass boost from 0 to +18dB @ 45Hz.

**REMOTE BASS LEVEL CONTROL (RBCF)**

This port is for connecting the remote subwoofer level control. This allows up to 20dB of volume adjustment for the subwoofer channel. This is not a bass boost, it controls the level of the low pass signal.

NOTE: This control is not compatible with the Phoenix Gold LPL44 level control.

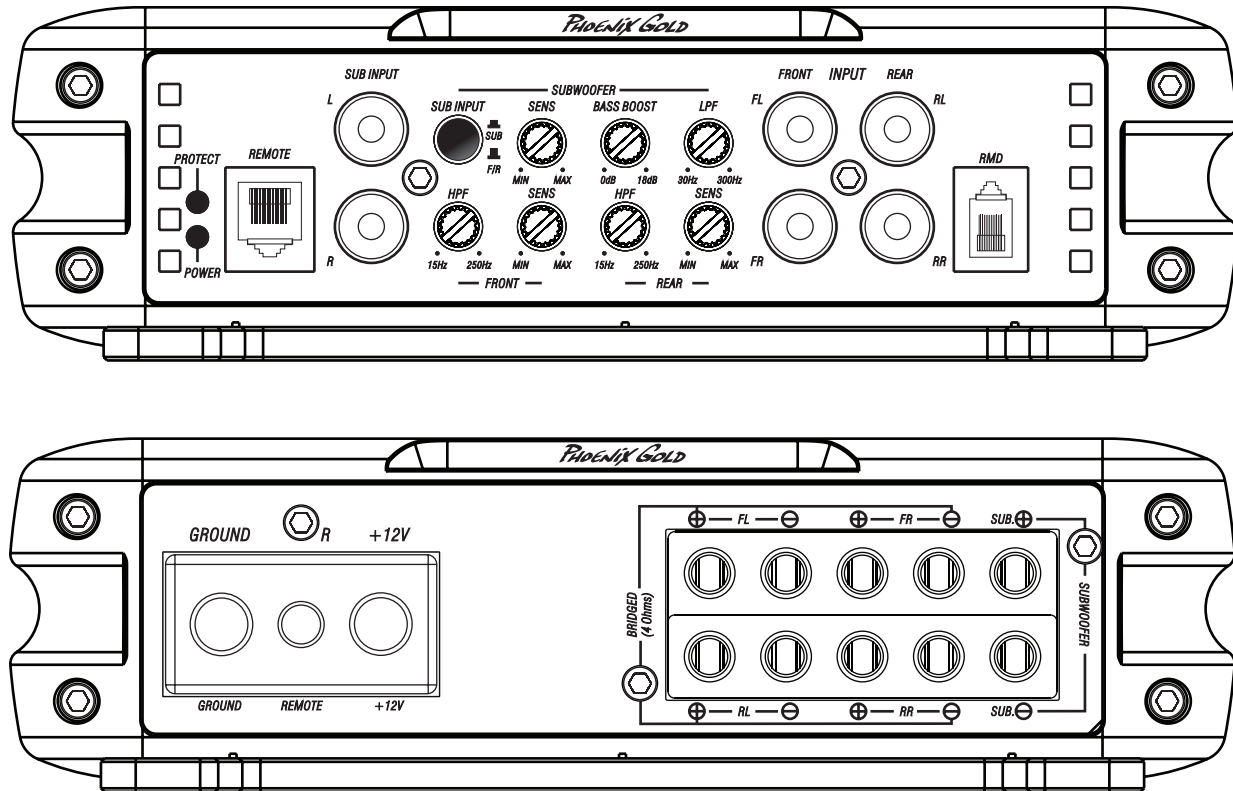

**+12V**

This must be connected to the fused positive terminal (+12V) of the car's battery. The fuse must be located within 18 inches of the battery.

**REMOTE**

This must be connected to switched +12V, usually a trigger wire coming from the head unit or ignition.

**GROUND**

This must be connected to the negative terminal of the car's battery or bolted to a clean, unpainted part of the chassis of the vehicle.

**REMOTE MONITORING DISPLAY (RMD)**

Connect optional RMD Voltage Display to this port.

**SPEAKER OUTPUTS**

Used to connect the amplifier to speakers. SD1100.5's minimum impedance is 4 ohms bridged or 2 ohms stereo on front and rear channels. Use the Left + and Right - to bridge the channels. Minimum impedance is 2 ohms for the subwoofer channel and its not bridgeable.

## SYSTEM TUNING

1. Install all system fuses.
2. Set the amplifier's input sensitivity controls to their minimum positions (full counterclockwise).
3. Set all amplifier crossover switches according to your system's design.
4. Make preliminary adjustments to the crossover frequency, usually 80Hz is good starting point for high and low pass. It may be necessary to fine tune the crossover frequency later for the best overall sound quality.
5. If using a Remote Subwoofer Level Control, set it to maximum (full clockwise).
6. Turn the headunit on with the volume set to minimum.
7. Visually check the amplifier's has turned on by the power LED.
8. Check the condition of all other components to make sure they are powered up.
9. Set the headunit's tone controls, balance, and fader to the center (flat) position. Turn off any loudness or other signal processing features.
10. Set the volume control of the headunit to 3/4 of maximum volume. Play music you typically listen to through the system.
11. Turn up the sensitivity or input level control on the amplifier until the speakers reach maximum undistorted output.
12. Repeat sensitivity level adjustments for all other amplifiers.
13. Reduce the headunit's volume to a comfortable level.
14. Listen to various musical selections to check overall system balance. Compare front to rear, midbass to midrange, etc. If one speaker set is too loud compared to another, then its level must be lowered to blend correctly with the other speakers.
15. Fine tune crossover frequencies to achieve the smoothest possible blending of each speaker set.
16. Adjust the Bass Equalization Controls on the amplifier, headunit or processor upstream if necessary to increase output.  
  
Note: Use these controls sparingly. Every 3dB of boost requires double the power at 45Hz. If your subwoofer system requires a lot of boost to sound good, there may be a problem. Look for out-of-phase woofers, a leaking subwoofer box, or incorrect box size.
17. With all levels set correctly, the system will reach overall maximum undistorted output at the volume level set in step 10.

## TROUBLESHOOTING

### **NO POWER:**

Check voltage at the amplifier with a DMM (volt meter), +12v and R (with head unit on) the voltage should register between 11.5V and 14.4V when using the attached ground lead of the amplifier. Check fuse at the battery. Use a meter to verify connection from one end of the fuse to the other, breaks may not always be visible. If the fuse is blown, check the power wire and also the amplifier for a short. If the short is in the amplifier itself, see your Phoenix Gold dealer. If a short is not present, replace the fuse.

### **POWER WITHOUT SOUND:**

Turn the amplifier off and check all input and output signal cables and power connections. Check the speakers for shorts with a DMM (volt meter) or by connecting them to another audio source. After making sure everything is correct, turn the amplifier on again.

### **NO SOUND FROM ONE OR MORE CHANNELS:**

Check the balance control in the head unit. Check speaker connections. Check signal input connection. Very low output: Check your head unit's fader control or the amplifier's input sensitivity level.

### **FREQUENT AMPLIFIER SHUTDOWN WITH AUTOMATIC RECOVERY:**

This indicates chronic amplifier thermal shutdown because of operation at consistently high internal temperatures. High operating temperature can be caused by inadequate ventilation. Make sure you are not running a lower than recommend impedance. Also check for damaged speakers or passive crossover systems. Finally, chronic thermal shutdown may result from otherwise normal operation of the amplifier at elevated output power levels, which can be resolved by providing additional amplifier cooling, installing a higher-power amplifier, or reducing amplifier output level.

### **POWER CYCLES ON/OFF QUICKLY:**

The power indicator going off repeatedly when the audio system is on. Check the amplifier's connection to the battery. Check battery voltage. If low, recharge or replace the battery. Check all ground connections.

## SD800.4 AMPLIFICADOR DE POTENCIA DE 4 CANALES

### ENTRADAS DELANTERA y TRACERA

Conectar cables de señal de preamp del radio a estas entradas. Ambas entradas, Front y Rear deben ser usadas, si solo se usa el Front no habrá señal en el Rear output.

### FRECUENCIA de CROSSOVER

Controla el nivel de frecuencia de crossover.

### BASS BOOST

Bajo variable de 0 a +18dB @ 45Hz.

### SENS

Usado para alcanzar el máximo poder amplificado con una gran variedad de radios.

### CONFIGURACION

FLAT: El crossover es off

HP: El crossover high pass es "on"

LP: El crossover low pass es "on"

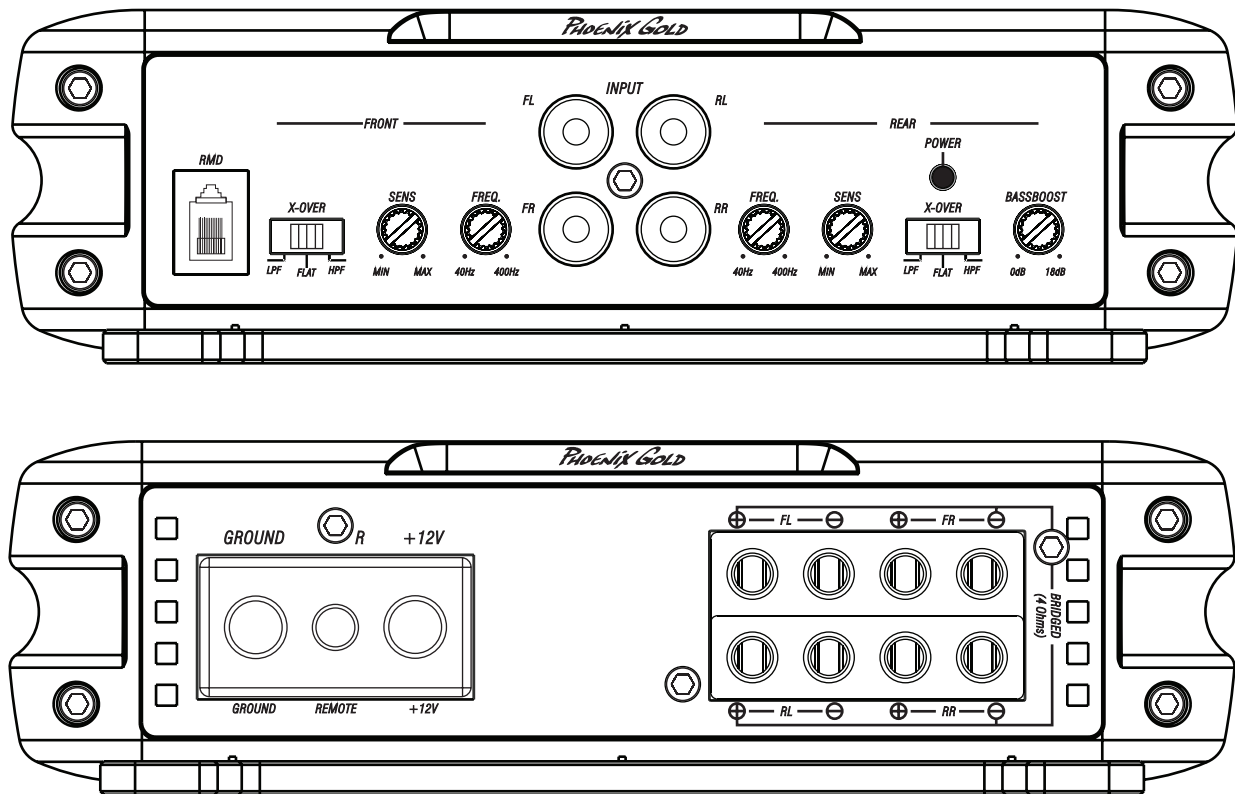

### +12V

Este debe ser conectado al fusible del terminal positivo (+12V) de la batería del auto. El fusible debe ser ubicado a menos de 18 pulgadas de la batería.

### REMOTO

Este debe ser conectado al switch +12V. Usualmente al cable de gatillo que viene del radio o del encendido.

### TIERRA

Este debe ser conectado al terminal negativo de la batería del auto o a una parte limpia y sin pintura del chasis del auto.

### DISPLAY PARA MONITOREO REMOTO (RMD)

Conectar el display de voltaje opcional RMD a este puerto.

### SALIDA de PARLANTES

Usado para conectar los parlantes. La mínima impedancia para el SD800.4 es 4 ohms o 2 ohms estéreo. Usar Left+ y Right - para el bridge.

## SD1100.5 AMPLIFICADOR DE POTENCIA DE 5 CANALES

### ENTRADAS

Conectar cables de señal de preamp del radio a estas entradas. Las entradas frontales, traseros y sub debe ser utilizado. Si una entrada no se utiliza no habrá salida para ese conjunto de canales.

### HPF/LPF FRECUENCIA de CROSSOVER

Controla el nivel de frecuencia de crossover.

### SUB SELECCION DE ENTRADE

Determina qué entrada se alimenta la señal en el canal de subwoofer. "IN" o SUB = Usar la entrada Sub  
"OUT" o F / R = Usa el frontal y las entradas traseras que su señal se sumarán luego enviado a la sub canal del amplificador.

### SENS

Usado para alcanzar el máximo poder amplificado con una gran variedad de radios.

### BASS BOOST

Bajo variable de 0 a +18dB @ 45Hz.

### CONTROL REMOTO de NIVEL de BAJOS

Este puerto es para conectar el control de nivel de bajos. Esto permite un ajuste de hasta 20dB de volumen. Este no es un bass boost, este controla el nivel de low pass signal.

NOTA: Este control no es compatible con el control de nivel Phoenix Gold LPL44.

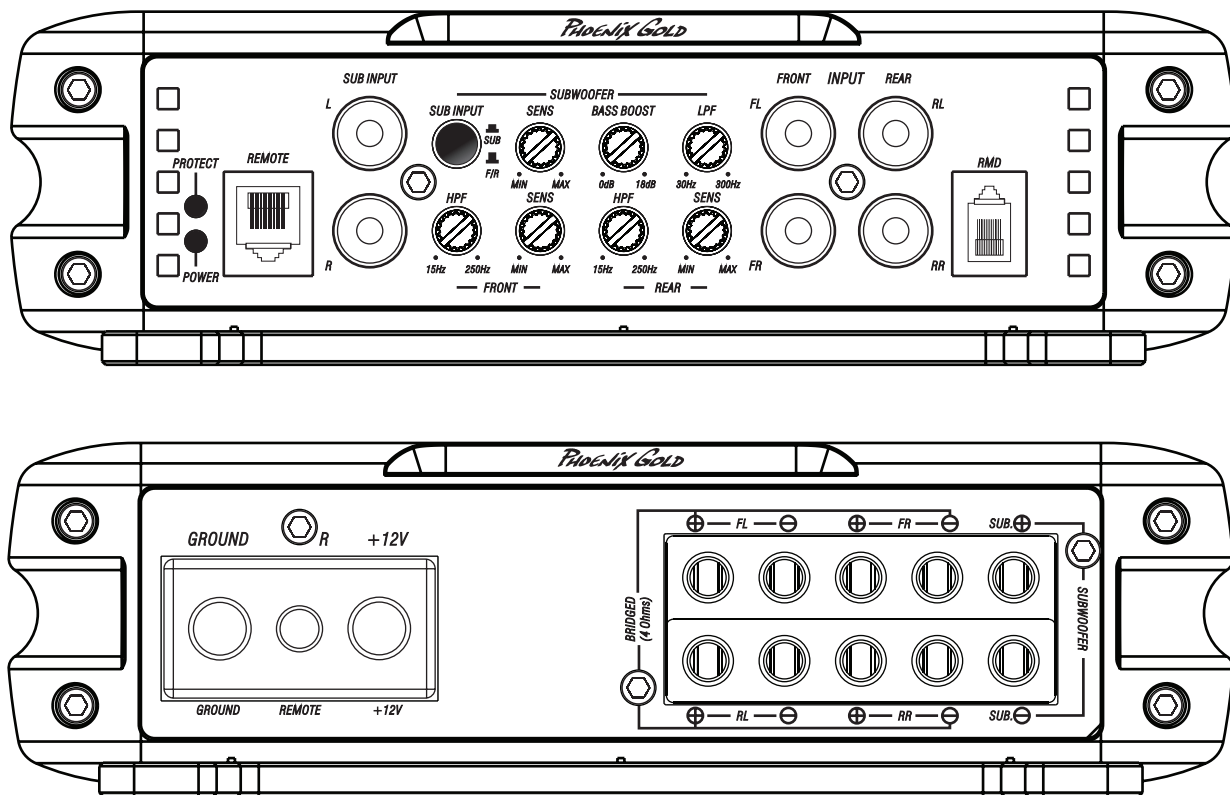

### +12V

Este debe ser conectado al fusible del terminal positivo (+12V) de la batería del auto. El fusible debe ser ubicado a menos de 18 pulgadas de la batería.

### REMOTO

Este debe ser conectado al swchic +12V. Usualmente al cable de gatillo que viene del radio o del encendido.

### TIERRA

Este debe ser conectado al terminal negativo de la batería del auto o a una parte limpia y sin pintura del chasis del auto.

### DISPLAY PARA MONITOREO REMOTO (RMD)

Conectar el display de voltaje opcional RMD a este puerto.

### SALIDA de PARLANTES

Usado para conectar los parlantes. La mínima impedancia para el SD1100.5 es 4 ohms o 2 ohms estéreo. Usar Left + y Right - para el bridge. Impedancia mínima es de 2 ohms para el canal de subwoofer y no es bridgeable.



**SISTEMA TUNING**

1. Instalar todos los fusibles del sistema
  2. Ajustar los controles de sensibilidad (input sensibility controls) del amplificador a la posición mínima (Contra reloj)
  3. Ajustar todos los switches de crossover de acuerdo al diseño de su sistema.
  4. Hacer los ajustes preliminares a la frecuencia del crossover, usualmente 80Hz es un buen punto de partida para high y low pass. Pudiera ser necesario luego ajustar la frecuencia del crossover para obtener la mejor calidad de sonido.
  5. Si se usa un control remoto del nivel de subwoofer, ajustarlo al máximo (en sentido del reloj)
  6. Encienda el radio con el volumen ajustado al mínimo
  7. Visualmente chequear que el amplificador se haya encendido, ver el power LED
  8. Chequear que todos los demás componentes estén encendidos
  9. Ajustar los controles de tonos del radio, balance y fader en la posición del medio. Apagar cualquier loudness u otro botón de proceso de señal.
  10. Ajustar el volumen del radio al máximo sin distorsión (en la mayoría de los radios el volumen máximo sin distorsión es 3 u 4) Use una grabación clara y dinámica.
  11. Suba la sensibilidad o el nivel de control de entrada en el amplificador hasta que los parlantes alcancen el mayor output sin distorsión.
  12. Repita los ajustes de niveles de sensibilidad para todos los otros amplificadores.
  13. Reduzca el volumen del radio al nivel más confortable.
  14. Escuche varias diferentes selecciones de música para chequear el balance general del sistema. Compare front y rear, midbass y midrange, etc. Si un parlante suena muy fuerte con respecto al otro, su nivel debe ser disminuido para obtener un buen balance.
- Nota: Para los subwoofers controlados por el control de nivel remoto, mantener el nivel del paso 11 o 12. Use el control para mezclar los subwoofers con el resto del sistema. El volumen correcto del subwoofer cambiara dependiendo del ruido en el ambiente, carretera y las diferencias en las grabaciones.
15. Afinación del ajuste de frecuencias de crossover para obtener la mejor mezcla posible de cada set de parlantes.
  16. Ajuste de los controles de equalización de bajos en el amplificador, radio o procesador si es necesario aumentar el output. .
- Nota: Use los controles prudentemente. Cada incremento de 3dB requiere el doble de poder a 45Hz. Si su sistema de subwoofer requiere mucho aumento para un mejor sonido, probablemente exista un problema. Fíjese si los subwoofers están out-of-phase, hay escape en el cajón del subwoofer, o el tamaño del cajón es incorrecto
17. Con todos los niveles ajustados correctamente, el sistema alcanzara el máximo output sin distorsión al nivel de volumen ajustado en el paso 10.

**CORRECCIÓN DE PROBLEMAS**

No poder: Chequear el voltaje al amplificador con un DMM (voltímetro). +12v y R (con el radio encendido) el voltaje debería ser entre 11.5V y 14.4V cuando se usa la tierra del amplificador. Chequear el fusible del amplificador y la batería. Verificar la conexión desde un final del fusible hasta el otro con un meter, a veces las rupturas no son visibles. Si el fusible está quemado, chequear el cable de poder y también el amplificador por un corto. Si el corto es en el amplificador, llévelo a su agente autorizado Phoenix Gold. Si no hay corto, solo reemplace el fusible.

Poder pero no sonido: Apague el amplificador y chequee todos los cables de señal de entrada y salida, y las conexiones de poder. Chequear los parlantes para ver si hay corto con un DMM (voltímetro) o conectándolos a otra fuente de sonido. Luego de chequear que todo este correcto puede encender el amplificador.

No sonido de uno o más canales: Chequear por exceso de voltaje en los terminales de +12V y tierra. Chequear el control de balance del radio. Chequear las conexiones de los parlantes. Chequear la conexión de señal de input.

Muy bajo output: Chequear el control de fader del radio o el nivel de sensibilidad de input del amplificador. Asegurarse que el control de frecuencia subsónica no esté demasiado alto y el control de frecuencia LP no esté muy bajo al mismo tiempo.

Frecuentes apagados del amplificador con reencendido automáticamente: Este indica apagado crónico del amplificador por constante operación a alta temperatura interna. Operación a alta temperatura puede ser causa de inadecuada ventilación. Asegúrese que no está operando a una impedancia menor a la recomendada. También chequee por daños en los parlantes, o passive crossover. Finalmente, apagados térmicos crónicos pueden ser el resultado de otras operaciones normales del amplificador a elevados niveles de output, lo cual puede ser solucionado previendo adicional enfriamiento al amplificador, instalando un amplificador de alto poder o reduciendo el nivel de output.

"Motor Boating" – El indicador de poder se apaga repetitivamente cuando el sistema esta encendido: Chequear la conexión del amplificador a la batería. Chequear el voltaje de la batería. Si es bajo, recargar o reemplazar la batería. Chequear las conexiones de tierra.

## SD800.4 AMPLIFICATEUR DE PUISSANCE

### ENTRÉE

Reliez les câbles de signal préampli de l'unité principale sur ces bornes.

### FRÉQUENCE DE FILTRE PASSIF PASSE-BAS et PASSE-HAUT

Contrôle les points de filtre pour les sorties du haut-parleur.

### AMPLIFICATION DES BASSES

Amplification des basses variable de 0 à +18 dB à 45Hz.

### NIVEAU

Sert à atteindre une puissance d'amplificateur maximale avec une grande variété d'unités principales.

### CONFIG

FLAT : Croisé est éteint.

HP : L'haute passe croisée est sur.

LP : Le niveau bas passe croisé est sur.

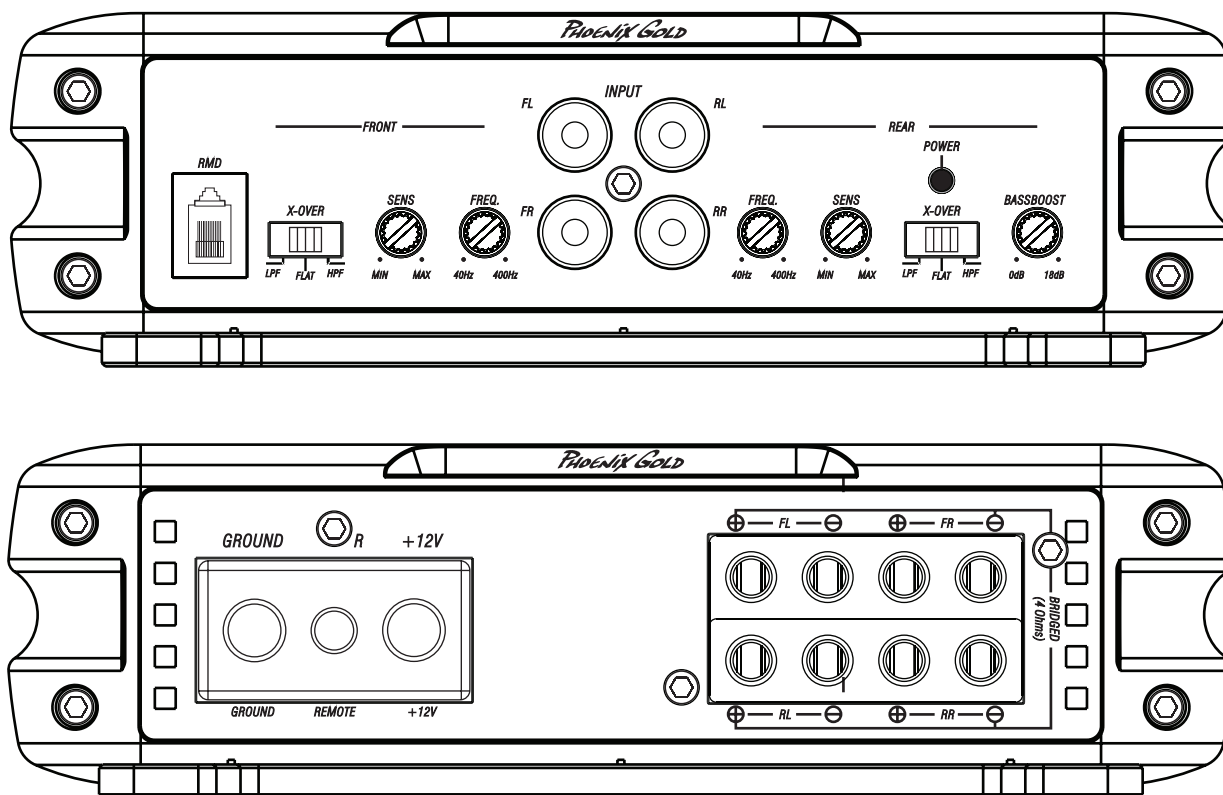

### +12V

Doit être relié à la borne positive protégée par fusible (+12 V) de la batterie de la voiture. Le fusible doit être situé à moins de 18 pouces de la batterie.

### BORNE TÉLÉCOMMANDE

Doit être relié à la borne +12 V commutée, généralement un fil d'amorçage sortant de l'unité principale ou de l'allumage.

### MASSE

Doit être relié à la borne négative de la batterie de la voiture ou boulonné sur un élément propre et non peint du châssis du véhicule.

### ENTRÉE DE L'AFFICHAGE DE TENSION A DISTANCE (RMD)

Connectez le RMD d'affichage de tension facultatif à cette prise jack.

### SORTIES ENCEINTES

Utilisé pour connecter l'amplificateur aux enceintes. SD800.4 impédance minimale est de 4 ohms ponté ou stéréo 2 ohms.

**SD1100.5**  
**AMPLIFICATEUR DE PUISSANCE**

**ENTRÉE**

Reliez les câbles de signal préampli de l'unité principale sur ces bornes.

**FRÉQUENCE DE FILTRE PASSIF PASSE-BAS et PASSE-HAUT**

Contrôle les points de filtre pour les sorties du haut-parleur.

**AMPLIFICATION DES BASSES**

Amplification des basses variable de 0 à +18 dB à 45Hz.

**NIVEAU**

Sert à atteindre une puissance d'amplificateur maximale avec une grande variété d'unités principales.

**COMMANDE À DISTANCE DU NIVEAU DES BASSES**

Ce port sert à connecter la télécommande de niveau. Cela permet un ajustement du volume allant jusqu'à 20 dB. Ce n'est pas une amplification des basses mais permet de contrôler le niveau du signal du filtre passe-bas.

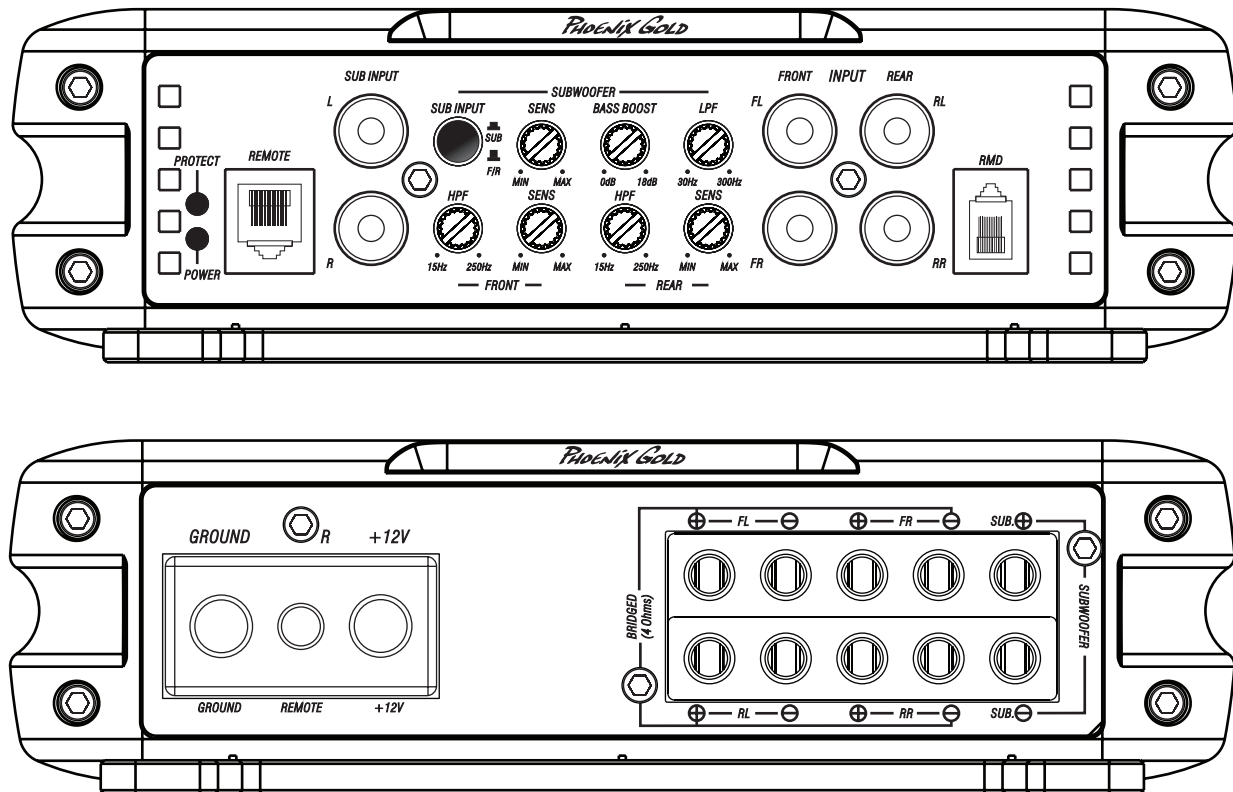

**+12V**

Doit être relié à la borne positive protégée par fusible (+12 V) de la batterie de la voiture. Le fusible doit être situé à moins de 18 pouces de la batterie.

**BORNE TÉLÉCOMMANDE**

Doit être relié à la borne +12 V commutée, généralement un fil d'amorçage sortant de l'unité principale ou de l'allumage.

**MASSE**

Doit être relié à la borne négative de la batterie de la voiture ou boulonné sur un élément propre et non peint du châssis du véhicule.

**ENTRÉE DE L'AFFICHAGE DE TENSION A DISTANCE (RMD)**

Connectez le RMD d'affichage de tension facultatif à cette prise jack.

**SORTIES ENCEINTES**

Utilisé pour connecter l'amplificateur aux haut-parleurs. SD1100.5 impédance d'minimum est de 4 ohms ponté ou 2 ohms stéréo.

**SÉLECTION D'ENTRÉE SUB**

Détermine quelle source sera signal de nourrir le canal de subwoofer.

"IN" ou SUB = utiliser l'entrée Sub

"OUT" ou F / R = Utilisez le Front et les entrées arrières comme son signal seront additionnées puis envoyé à la sous-canal de l'amplificateur.

# PHOENIX GOLD

Phoenix Gold  
A Division of AAMP of America™  
13190 56th Court  
Clearwater, Florida 33760  
P: 888-228-5560  
info@phoenixgold.com  
www.phoenixgold.com  
© 2013 AAMP of Florida, Inc

Designed and Engineered in the USA

## LIMITED WARRANTY ON AMPLIFIERS

Phoenix Gold warrants this product to be free of defects in materials and workmanship for a period of one (1) year from the original date of purchase. This warranty is not transferable and applies only to the original purchaser from an authorized Phoenix Gold dealer in the United States of America only. Should service be necessary under this warranty for any reason due to manufacturing defect or malfunction, Phoenix Gold will (at its discretion), repair or replace the defective product with new or remanufactured product at no charge. Damage caused by the following is not covered under warranty: accident, misuse, abuse, product modification or neglect, failure to follow installation instructions, unauthorized repair attempts, misrepresentations by the seller. This warranty does not cover incidental or consequential damages and does not cover the cost of removing or reinstalling the unit(s). Cosmetic damage due to accident or normal wear and tear is not covered under warranty.

## INTERNATIONAL WARRANTIES:

Products purchased outside the United States of America are covered only by that country's Authorized Phoenix Gold reseller and not by Phoenix Gold. Consumers needing service or warranty information for these products must contact that country's reseller for information.