



# 5100 $8 \Omega$

# B38

## PROFESSIONAL SERIES

## 15" Bass Midrange Driver High Sound Pressure Level High Efficiency - Contact Class

### APPLICATIONS

Built according to the same concepts as SP5050, this model which belongs to our sound reinforcement Contact Class is equipped with a classical two layer coil, which allows it to be used in larger Reflex enclosures (80L to 110L tuned at 40Hz) with the same sound qualities as the SP5050.

SP5100 can also be X-overed up to 800Hz, and exhibits a good quality to price ratio.

### DESIGN CONCEPT

**DEFLECTION CONTROLLED DIAPHRAGM** optimized for dynamic damping. DEFLECTION CONTROLLED DIAPHRAGM technology consists in optimizing the shape and material of the diaphragm so that it works as a mechanical transmission line, to avoid breaking modes as well as mechanical threshold which destroy sound quality.

This leading edge technology offers substantial sonic advantages. Among them: sound coherency, fast transients, stable sound imaging, high sensitivity, wide frequency range and reduced directivity pattern.

**VENTED COMPACT MAGNET SYSTEM.** It has been carefully optimized to obtain maximum transducing efficiency while avoiding unlinear behavior such as coil inductance variation with position, flux modulation, harmonic distortion, rest position offset, air compression and off-axis voice-coil pushing.

Its design incorporates a T-shaped and vented pole piece, and a flux stabilization ring. It also takes into consideration demagnetization at cold temperatures.

**INTERCOOLER SYSTEM** (patented). Entirely integrated into the loudspeaker itself, the INTERCOOLER SYSTEM extracts the heat produced by Joule effect in the voice-coil by the means of an air flow directed through the heatsink rims of the basket by the motion of the dust-cap and the spider.

The gain brought about by this technology is over 20 % of extra power, so for example, a 3" coil according to this design has the same power handling capacity as a classical 4" one.



### FEATURES

Power handling capacity **400 W AES**  
Reference efficiency (1W @ 1m) **98 dB SPL**  
SPL max (continuous) **120 dB SPL**  
Usable frequency range **40-1500 Hz**  
Environmental withstanding **Outdoor**

### ARCHITECTURAL SPECIFICATIONS

**NOMINAL DIAMETER** : 380 mm.

**FRAME** : High tensile alloy pressure die-cast basket with patented INTERCOOLER SYSTEM.

**MAGNET SYSTEM** : 3" highly energized, heat extracting design with vented pole piece and flux stabilizing ring.

**VOICE COIL** : High-temperature stabilized copper wire wound on high-strength glass polyimide former.

**CONE ASSEMBLY** : High-strength cellulose fiber cone and central dome impregnated and front-coated with damped resins, fitted with high compliance treated double-roll fabric surround.

**SPEAKER MASS** : 9.10 kg

# 5100

## 15" Bass Driver

### 5100

#### TYPICAL CHARACTERISTICS

Rated impedance	Z	8	Ω
Reference efficiency (1 W@1 m)	-	98	dB SPL
Usable frequency range <sup>1</sup>	-	40-1500	Hz
Power handling capacity <sup>2</sup> (AES)	-	400	W
Max Sound Pressure Level <sup>3</sup>	SPL <sub>max</sub>	120	dB SPL
Min. impedance modulus	Z <sub>min</sub>	6.5 @ 220Hz	Ω
Voice-coil inductance <sup>4</sup> @ 1 kHz	L <sub>e1k</sub>	1.41	mH
@ 10 kHz	L <sub>e10k</sub>	0.58	mH
Bl product	Bl	20.8	N/A
Moving mass	M <sub>ms</sub>	0.102	Kg

#### THIELE-SMALL PARAMETERS : TYPICAL (QC LIMITS)

Resonance frequency <sup>5</sup>	F <sub>s</sub>	39 (±5)	Hz
DC resistance <sup>6</sup>	R <sub>e</sub>	5.6 (±0.5)	Ω
Mechanical quality factor	Q <sub>ms</sub>	4.2	1
Electrical quality factor	Q <sub>es</sub>	0.32	1
Total quality factor	Q <sub>ts</sub>	0.30	1
Mechanical suspension compliance	C <sub>ms</sub>	160	10 <sup>-4</sup> m/N
Effective piston area	S <sub>d</sub>	0.0892	m <sup>2</sup>
Equivalent C <sub>as</sub> air load	V <sub>as</sub>	0.180	m <sup>3</sup>
Max. linear excursion	X <sub>max</sub>	± 7.0	mm
Linear displacement volume	V <sub>d</sub>	0.624	10 <sup>-3</sup> m <sup>3</sup>
Half-space efficiency		3.2	%
Unity load volume	V <sub>as</sub> Q <sub>ts</sub> <sup>2</sup>	16.4	10 <sup>-3</sup> m <sup>3</sup>

#### ABSOLUTE MAXIMUM RATINGS

Short term max. input voltage <sup>7</sup>	V <sub>max</sub>	125	V
Max. excursion before damage	X <sub>dam</sub>	14	mm
Ambient operating temperature		-10 to +50	°C
Storage temperature <sup>8</sup>		-20 to +70	°C
Environmental conditions <sup>9</sup>		Outdoor	

#### APPLICATION INFORMATION

Air volume occupied by the driver <sup>10</sup>		4.3	10 <sup>-3</sup> m <sup>3</sup>
Speaker net mass		9.1	Kg
Recommended reflex box	V <sub>b</sub> /F <sub>b</sub>	65 / 55	L / Hz
Electrical polarity	A positive voltage applied on the red terminal produces forward cone motion.		

#### PHYSICAL CHARACTERISTICS

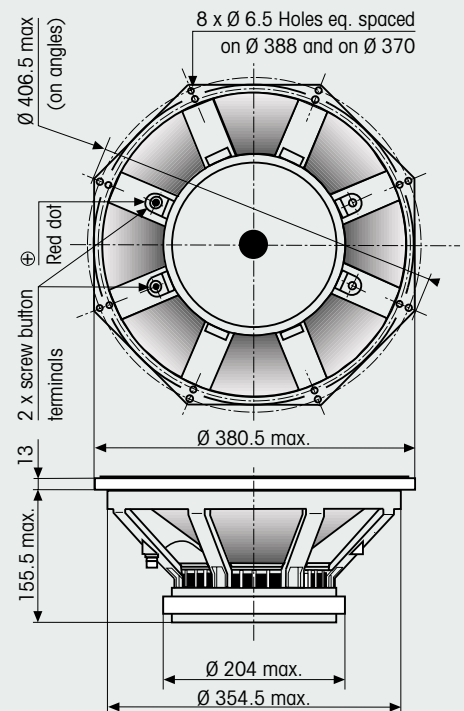

#### SPECIFICATION NOTES

- Note 1 : Allowing for energy response, excursion capability, Power spectrum, and -3dB low freq. roll-off for standard reflex tuning.
- Note 2 : Established at 20°C ambient temp, according to AES2-1984 standard using IEC268-1 simulated programme signal and a 75 liter Bass-Reflex test enclosure tuned at 45Hz.
- Note 3 : Established at 1m on axis of the loudspeaker mounted in test enclosure, when driven at full AES Power Handling Capacity, including 4dB of thermal compression loss.
- Note 4 : Measured at 20 mA in free air.
- Note 5 : Measured at 20 mA and 20°C ambient temp. in free air conditions, after full run and rest.
- Note 6 : Measured at 20°C ambient temp. QC limits are ±10%
- Note 7 : Stated in RMS voltage according to IEC 268-5.
- Note 8 : Includes shipping conditions. The lower limit prevents from demagnetization.
- Note 9 : Our products are classified in three categories : Indoor, Outdoor, and Outdoor+ for permanent outdoor use or severe conditions.
- Note 10 : Calculated for front mounting on to a 18 mm thick board.

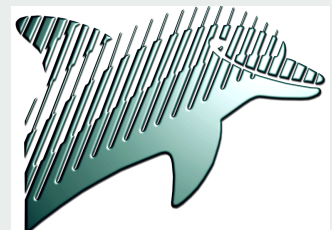

**PHL**  
A U D I O  
461, rue des chênes . Z.A  
77590 CHARTRETTES  
FRANCE

Tél : 33 01 64 81 29 80

Fax : 33 01 60 69 10 28

e-mail : [phlaudio@phlaudio.com](mailto:phlaudio@phlaudio.com)

<http://www.phlaudio.com>