

# OWNERS MANUAL

## Small Concrete Saw



MODEL:  
**C9**

FORM <<7418 3/2005

*clipper*

# WARRANTY

Norton warrants all products manufactured by it against defects in workmanship or materials for a period of one (1) year from the date of shipment to the customer.

The responsibility of Norton under this warranty is limited to replacement or repair of defective parts at Norton's Gainesville, Georgia factory, or at a point designated by it, of such part as shall appear to us upon inspection at such point, to have been defective in material or workmanship, with expense for transportation borne by the customer.

In no event shall Norton be liable for consequential or incidental damages arising out of the failure of any product to operate properly.

Integral units such as **gasoline engines, electric motors, batteries, tires, transmissions, etc.**, are excluded from this warranty and are subject to the prime manufacturer's warranty.

This warranty is in lieu of all other warranties, expressed or implied, and all such other warranties are hereby disclaimed.

**Important: Before placing equipment in operation, record the following information.**

**MODEL:** \_\_\_\_\_ **SERIAL NO.** \_\_\_\_\_

**PURCHASE FROM:** \_\_\_\_\_

**ADDRESS:** \_\_\_\_\_

**CITY** \_\_\_\_\_ **STATE** \_\_\_\_\_ **ZIP** \_\_\_\_\_

**TELEPHONE NO.** \_\_\_\_\_

***Before using this equipment, make sure that person using it read and understand the instructions in this owner's manual.***

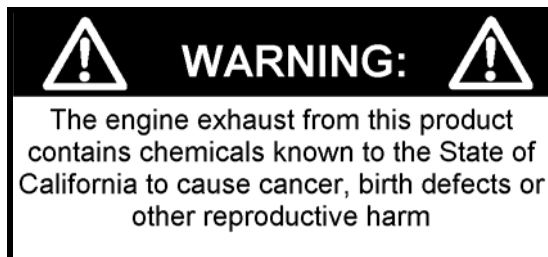

# Table Of Contents

CONTENTS	PAGE
<b>I. Preparation</b>	
A. Safety Precautions	4-6
B. Assembly	7
C. C9 Series Concrete Saw Specifications	8
D. Engine Specifications	9
E. Pointer Alignment	9
<b>II. Operation</b>	
A. Blade Installation	9-10
B. Starting The Engine	10
C. Water Supply	10-11
D. Operating The Saw	11
E. Cutting Technique	12
<b>III. Maintenance</b>	
A. Engine	13-14
B. Bearings	14-15
C. V-Belts	15-16
D. Depth Control	16
<b>IV. Parts List Section</b>	
A. Ordering Information	17
B. Parts Drawing	18-19
C. Service Parts List	20



## Read Owners Manual Before Use

Safety Alert Symbol: Information Following This Symbol Is Very Important.

## Use Only Clipper Diamond Blades

# I. PREPARATION

## A. Safety Precautions

**Important! The following safety precautions must always be observed.**

### Hazard Symbols



Fuel (gasoline) is extremely flammable and its vapors can explode if ignited. Store gasoline only in approved containers, in well-ventilated, unoccupied approved areas, and away from sparks or flames. Do not fill the fuel tank while the engine is hot or running. Do not start the engine near spilled fuel. Never use the fuel as a cleaning agent



Engine components can get extremely hot from operation. To prevent burns, do not touch the engine or related parts while the engine is running or immediately after it is turned off. Never operate the engine with any heat shields or guards removed.



Keep all guards in place when operating any piece of equipment



Keep hands, feet, hair, and clothing away from all rotating parts



Lethal Exhaust Gas use only in well ventilated areas. Engine exhaust gases contain poisonous carbon monoxide, which is odorless, colorless, and can cause death if inhaled. Avoid inhaling exhaust fumes, and never run the engine in a closed building or confined area



Never tamper with the governor components of settings to increase the maximum speed. Severe personal injury and damage to the engine or equipment can result if operated at speed above maximum. Always obey the maximum speed rating of blade.



**DO NOT LIFT THE SAW BY THE HANDLE BARS**

# **WARNING**

## **Dust and Silica Warning**

Grinding/cutting/drilling of masonry, concrete, metal and other materials can generate dust, mists and fumes containing chemicals known to cause serious or fatal injury or illness, such as respiratory disease, cancer, birth defects or other reproductive harm. If you are unfamiliar with the risks associated with the particular process and/or material being cut or the composition of the tool being used, review the material safety data sheet and/or consult your employer, the material manufacturer/supplier, governmental agencies such as OSHA and NIOSH and other sources on hazardous materials and make certain to comply with all product warnings and instructions for the safe and effective use of the material being cut. California and some other authorities, for instance, have published lists of substances known to cause cancer, reproductive toxicity, or other harmful effects.

Control dust, mist and fumes at the source where possible. In this regard use good work practices and follow the recommendations of the manufacturer/supplier, OSHA/NIOSH, and occupational and trade associations. Water should be used for dust suppression when wet cutting is feasible. When the hazards from inhalation of dust, mists and fumes cannot be eliminated through engineering controls such as either vacuum and/or water mist, the operator and any bystanders should always wear a respirator approved by NIOSH/MSHA for the material being cut.

### **Use Approved:**



**Eye Protection**



**Hearing Protection**



**Respiratory Protection**



**Head Protection**

1. Before mounting any blade on the saw, the blade should be inspected for any damage which might have occurred during shipment, handling or previous use.
2. The blade collars and arbors should be cleaned and examined for damage before mounting the blade.
3. The blade must be properly fitted over the arbor with the drive pin on the outside collar projecting through the drive pin hole on the blade and inside collar.
4. The blade shaft nut, which is a left-hand thread nut, must be tightened securely against the outside blade shaft collar.
5. The blade must be operated within the specified maximum operating speed listed on the blade.
6. Turn water control valve to full to provide adequate coolant (4 to 6 gallons per minute) for diamond blades and wet cutting abrasive blades. Insufficient coolant could result in severe blade breakage or diamond segment separation.
7. The blade guard must be in place with the nose guard down and locked when the saw is running.
8. The operator should wear safety glasses and any other appropriate safety equipment.
9. When starting the saw, the operator should stand away and to the side of the blade.
10. If for any reason the saw should stall in the cut, raise the blade out of the cut. Check the outside blade shaft collar and nut for tightness. Inspect the blade for damage before restarting the saw. Use caution when resuming a cut. Be certain that the blade is in alignment with the previous cut.
11. During cutting operations, do not exert excess side pressure on the handles as a method of steering. Do not force the blade into the cut by lowering the blade too fast or by pushing the saw too fast.



**You Are Responsible For Your Safety!!!**

# **I. PREPARATION**

## **B. Assembly**

The compact concrete saws are shipped completely assembled and ready for use except for diamond blade, gasoline, oil, and handle bar. Inspect the saw for shipping damage. If any damage is found, contact the shipper immediately and file a freight claim. The Norton Company is not responsible for any freight-related damages. Remove the saw from the pallet. Reverse the position of the handlebars so that the handle bar sticks out towards the operator. Adjust the handlebars to the desired height. Attach the handlebars to the saw with the supplied hardware. Read and understand the remaining sections of this Owners Manual. **NOTE:** Do not install the blade until it is time to use the saw. ANSI regulations prohibit the transportation of any concrete saw with the blade installed.

## C. C9 Series Concrete Saw Specifications

<b>Dimensions/Weight</b>	
Length (Working)	50" (1270 mm)
Length (Transport)	40.5" (1029 mm)
Width	20.5" (521 mm)
Height	41" (1041 mm)
Weight	195 lbs (88.6 kg)
<b>Engine</b>	
Engine Mfg.	Honda
Model	GX270
Spec No.	GX270K1QXC9
Engine Type	Single Cylinder 4 Cycle
Horse Power	9 hp (6.65 kW) @ 3,600 rpm
Max Torque	19.5 ft-lbs (26.5 Nm, 2.7 kg-m) @ 2,500 rpm
Cooling System	Air
Oil Capacity	1.1 liter (1.16 US qt)
Fuel Capacity	6.5 liter (1.79 US gal)
Fuel Type	Unleaded Gasoline (86 pump octane)
Low Oil Sensor	Yes
Air Filtration	Four Stage Cyclone
<b>Characteristics</b>	
Max Blade	Ø14" (356 mm)
Depth of Cut	5.75" (146 mm)
14" (356 mm)	4.75" (121 mm)
12" (305 mm)	3.75" (95 mm)
Arbor Bore	1" (25.4 mm)
Blade Shaft Locking Device	Machined Into Flats Of Tight Collar
Blade Shaft Speed	2850 rpm
Depth Control	Hand Wheel With Screw Feed
Depth Lock	Standard
Depth Gauge	Customer Installed Accessory
Number Of V-Belts	3
Blade Guard Type	Hinged, All Steel Construction
Right or Left Side Cutting	Yes
Lifting Bale	Built In
Handle Bars	Adjustable, Stays Level At All Times
Water Tank	Standard
Water Tank Capacity	5.28 US Gallons (20 liter)
Water Hose Connector	Standard Garden Hose With Flow Control Valve
Recessed Rear Wheels	Standard
Sound pressure <sup>1</sup>	88 db(A)
Sound power <sup>1</sup>	105 db(A)

1) the sound measures have been made following pr EN 12638, Annex A; 2) " Floor sawing, grooving and milling machines – Safety "



## D. Engine

***Prior to attempting to operate the engine, read the information contained in the engine owner's manual. An engine owners manual is supplied with every gasoline powered concrete saw.***

1. **Check Oil:** Add oil if low. Refer to the engine owner's manual for the recommended SAE viscosity grades. Capacity of oil is 1.1 liters (1.16 US qt)
2. **Check Fuel:** Fill if low. Use only unleaded gasoline with a pump sticker octane rating of 86 or higher is recommended. **Never use an oil and gasoline mixture!**
3. **Air Cleaner:** Never run the engine without the air cleaner! Rapid engine wear will result from contaminants being drawn through the carburetor and into the engine.
4. **Engine Starting:** Refer to the engine owner's manual for proper engine starting procedure.

## E. Pointer Alignment

1. Use a straight edge, and carefully mark a line 12 feet long on a smooth level surface.
2. Place the saw blade on the marked line, move the saw to the center of the marked line and then lower the blade until it is about 1/16" above the marked line
3. Measure from each end of the saw frame to insure that the frame is parallel to the marked line. Adjust the saw as needed.
4. With the blade centered on the marked line and the saw frame parallel to the marked line, lower the front pointer.
5. Adjust the pointer by bending it until is aligned with the marked line.

## II. OPERATION

### A. Installing the Blade

1. Disconnect the spark plug and then insert the Blade Shaft Locking Pin into the Blade Shaft Locking hole.

2. Remove the blade shaft nut, (Turn clockwise) , and remove the outside collar.
3. Clean off any foreign particles on the clamping surfaces of both collars and on the mounting surface of the blade.
4. Place the blade on the blade shaft, lining up the drive pin hole in the blade with the drive pinhole in the inside collar.



Use only Clipper Diamond Blades. This machine was not designed for the use with abrasive blades.

5. Slide the outside blade shaft collar onto the blade shaft . The drive pin on the outside collar must project through the drive pin hole in the blade and into the inside collar.
6. Tighten the blade shaft nut (counter-clockwise) securely against the outside collar and remove the Blade Shaft Locking Pin.
7. Reconnect the spark plug.

## Blades Use Only Clipper Diamond Blades

### B. Starting the Engine

1. Refer to the engine owner's manual for the proper starting procedures.
2. Always cut with engine rpm in the full throttle setting.

### C. Water Supply

**Pressurized source:** Turn the water control to full "ON" when using wet cutting blades. The required flow rate is 4-6 gallons per minute.

**Water Tank on saw:** This supply is designed for use with dry blades to keep the dust levels down. The tank will not supply the proper water flow rates when used with wet cut only blades. Do not drink the water from this tank. Fill the tank with water only. Close the water tank valve. Attach the saws water supply hose to the tank outlet. Fill the tank with water. The capacity of the tank is 5 US Gallons. When you are ready to cut, adjust the water supply rate until a fine mist or a slow trickle is made. The use of water greatly decreases the amount of dust produced during the cutting process, aids in the cooling of the blade, and provides additional

stability. The water tank adds additional blast (weight) to the machine, which aids in keeping the diamond blade in the cut and reducing vibrations. We recommend that the water tank to be filled with water at all time the machine is in use.

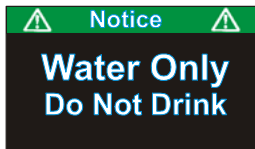

- Use Only Water In The Water Tank
- Do Not Drink From The Tank

## D. Operating the Saw

1. For blade installation instructions see section II. Operation sub heading A. Installing the Blade. For the engine starting instructions, see the Engine manual and follow the instructions located in section II. Operation sub heading B. Starting the Engine.
2. Check the Engine Oil level.
3. Raise the saw to the full upright position. Do not let the blade come in contact with the ground.
4. Maneuver the saw to the desired starting point.
5. If wet cutting, connect the water supply to the saw.
6. Follow the instructions for starting the engine found in the Engine manual.
7. If wet cutting, turn on the water supply at the source and then open the water valves on the saw. Make sure that there is a minimum of 4-6 gallons per minute of water flow!!
8. Be sure the engine is running at full throttle!!!
9. Slowly lower the blade by rotating the hand wheel clockwise until the desired depth of cut is reached. Use a reasonable rate of feed. Do not force the blade into the cut!!
10. When the end of the cut is reached, slowly raise the blade out of the cut by rotating the Hand Wheel counter-clockwise until the blade is at least one (1) inch above the ground.
12. Only move the saw in reverse with the blade in the raised position.

13. When moving the saw to a new location, be sure the blade is not touching the ground. Always pay close attention to where you are moving and where the blade is at all times.

## **E. Cutting Technique**

Lower the blade into the concrete to the required depth by turning the hand wheel clockwise.

Reduce the forward pressure if the saw begins to stall.

Note: For deeper cuts (4 inches or more), several cuts should be made in incremental steps of 1-1/2 to 2 inches until the desired depth of cut is reached.

Push the saw steadily forward using the front pointer as a guide. Exert enough forward pressure so that the engine begins to labor, but does not slow down. If the saw begins to stall, reduce the forward movement until full rpm is restored to the blade. If the saw stalls, raise the blade out of the cut before restarting. Avoid excessive side pressure or twisting of the blade in the cut.

### **Additional Guide Lines For Sawing:**

- Understand and follow all of the instructions in this owner's manual.
- If wet cutting, turn on the water supply so that there is a minimum of 4-6 gallons per minute of water flow!!
- In critically hard aggregate, more than a single pass may be needed to cut the desired depth.
- If the saw stalls in the cut, immediately stop the forward speed and raise the blade out of the cut. If this is not done the belts can fail or the blade may be damaged.
- Go slowly with a new blade until it opens up, that is, until the diamonds can be seen and felt.

### III. MAINTENANCE

#### A. Engine

Follow the below schedule for engine maintenance. NOTE: Check the Honda Engine manual that came with the engine for any changes to the maintenance schedule. If the charts have any differences, follow the chart in the Honda Engine Manual. The Norton Company does not warranty the engine. If any warranty or service of the engine is required contact your nearest Honda service center, or from the Internet: <http://www.honda-engines.com/home.htm>

Honda engine ( refer to owner's manual for complete maintenance.)

#### MAINTENANCE SCHEDULE

REGULAR SERVICE PERIOD Perform at every indicated operating hour interval.		EACH USE	FIRST 20HRS	EVERY 50HRS	EVERY 100HRS	EVERY 300HRS	Refer to page	
Engine oil	Check level	○					3-2	
	Change		○		○			
Reduction gear oil	Check level	○					3-2	
	Change		○			○		
Air cleaner	Check	○					3-3	
	Clean			○ (1)				
Fuel strainer cup	Clean				○		3-7	
Spark plug	Check-Clean				○		3-6	
Valve clearance	Check-Adjust					○	3-5	
Combustion chamber and valves	Clean-Lap					○	9-3,4	
Fuel line	Check (Replace if necessary)	Every 2 years						3-8

NOTE: (1) Service more frequently when used in dusty areas.

Check the engine oil level before each use when the engine is cool and the engine is level. Add oil if the level is low. The oil level should be within the operating range (see the engine owner's manual for details).

Only use a high-detergent, premium quality motor oil certified to meet or exceed U.S. automobile manufacturer's requirements for Service Classification SG, SF/CC, CD. Motor oils will show the classification on the container. A SAE viscosity of 10W-30 is recommended by Honda for general, all temperature use. Please consult the below chart or contact your local Honda service center for the proper viscosity for your temperature range.

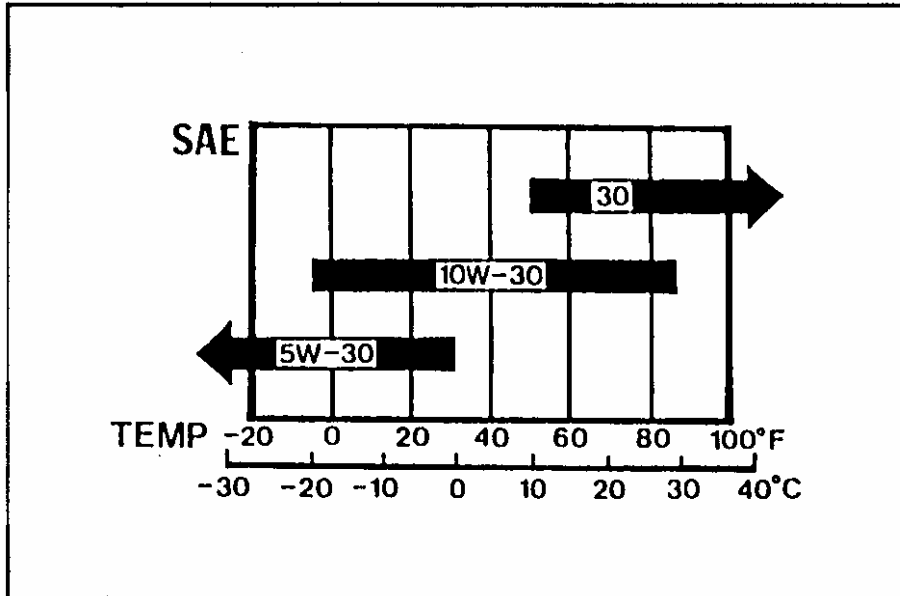

Always refer to the engine manual for more detailed information on checking the oil, changing oil, and oil capacity, air filter changes, and fuel type to use. Use only Honda air filters. Do not clean the air filter with gasoline or other flammable solvents. A fire or explosion could result. To clean, follow the instructions found in the Honda engine manual.

## Dry Cutting Engine Maintenance

- ✓ When operating the engine in dry cutting or dusty environments the following is required:
- ✓ Engine oil changed more often.
- ✓ Every 50 hours (or more often if conditions require) clean all of the engine cooling fins.
- ✓ Every 25 hours (or more often if conditions require) clean the engine precleaner.
- ✓ Every 100 hours (or more often if conditions require) replace the air filter. If the engine is equipped with a reusable air cleaner, clean and re-oil it.
- ✓ Check and clean the air filter after each use. Replace as needed.

## B. Bearings

Re lubrication type bearings must be relubricated **daily** to assure long life. The grease used should conform to the NLGI grade two and be free of any chemical impurities such as free acid or free alkali, dust, rust, metal particles or abrasives.

For best results, bearings should be relubricated while in operation. **Note: Due caution for personal safety must be observed when servicing rotating equipment.** The grease should be pumped in slowly until a slight bead forms around the seals. This bead, in addition to acting as an indicator of adequate relubrication, provides additional protection against the entry of foreign matter. If necessary to relubricate while the bearing is idle refer to relubrication table for maximum grease capacity for the various size bearings.

Shaft Size	Maximum Grease Capacity of Bearing Chamber in Ounces
1/2" to 3/4"	1/8
7/8" to 1-3/16"	3/8
1-1/4" to 1-1/2"	5/8

### C. V-Belts

**Warning: Never make adjustments to belts or pulleys while engine is running!**

1. The best tension for a belt drive is the lowest tension at which the belts will not slip under full load.
2. Simply take up the drive until the belts are snug in the grooves. Run the drive for about 15 minutes to "seat" the belts. Then impose the peak load. If the belts slip, tighten them until they no longer slip at peak load.
3. **Remember, too much tension shortens belt and bearing life!**
4. Check the belt tension frequently during the first day of operation. Check the belt tension periodically thereafter and make any necessary adjustments.
5. The two most common causes of misalignment are shown in the drawing.
  - a). The engine drive shaft and the blade shaft are not parallel.
  - b). The pulleys are not located properly on the shafts.
6. To check alignment, all you need is a steel straight edge.

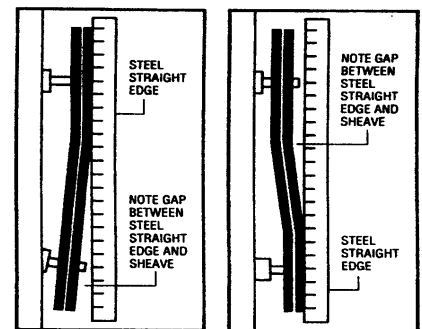

FIGURE 1

FIGURE 2

7. Line up the straight edge along the outside face of both pulleys as shown in the drawing.
8. Misalignment will show up as a gap between the pulley face and the straight edge.
9. Make sure that the width of the outside land (area between the belt and the edge of the pulley) is equal on both pulleys.

#### **D. Depth Control**

The depth control (raising screw) consists of a threaded rod, which feeds into a brass nut. In order to keep the two parts working smoothly it is necessary to keep the rod free from dirt and sludge as much as possible. Cleaning the threaded rod with a rag after each use will prevent sludge from collecting in the tube assembly and protect the threads. It is a good practice to keep the raising screw threads lubricated, as the slurry generated during cutting will cause premature thread wear.

The bearing used to support the raising screw should be checked after each use to make sure it is turning freely and lubricated. If the bearing requires re lubrication lithium base grease is recommended.



## IV. PARTS LIST SECTION

### A. Ordering Information

1. List model number and serial number of machine.
2. List part number and serial number of part not the item number.
3. Wherever alternate parts are shown due to product improvement, inspect the part you have and provide additional description as necessary.
4. Specify mode of shipping desired, such as, parcel post, truck, U.P.S., best way, etc.

For the nearest Clipper distributor call 1-800-554-8003

#### Common Replacement Parts

Description	Part Number
Belts V-belts XPA 710LW (set of 3)	83480
Blade Shaft Nut $\frac{3}{4}$ -16 Left Hand Thread (Operators Right Side Of Saw)	227156
Collar Tight (Operators Right Side)	227159
Collar Loose Assembly (With Pin)	227247
Drive Pin $\varnothing$ 3/8 x 1	227154
Bearing Blade Shaft (1)	72474
Front Wheel Complete (1)	80992
Rear Wheel (1)	80991
Wrench 1-1/2"	105377
Wrench 32mm	82910
Wrench 17mm	72279

NOTE: All Parts Are Sold As Individual (each) Unless Noted Otherwise

**Blades Use Only Clipper Diamond Blades.** Contact your local Clipper Distributor or Clipper at 1-800-554-8003 for the best blade for the application.

# C9 Parts Drawing

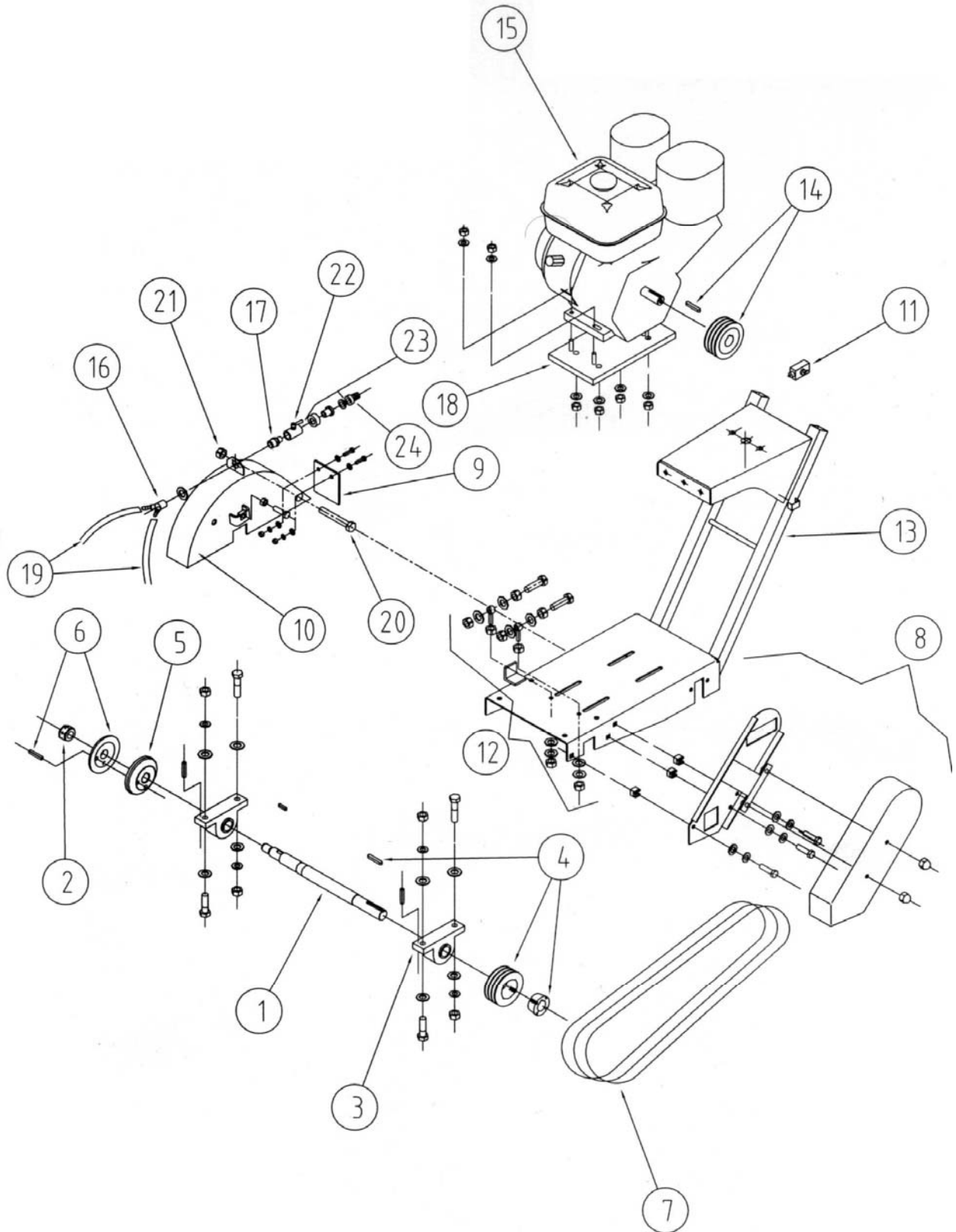

# C9 Parts Drawing

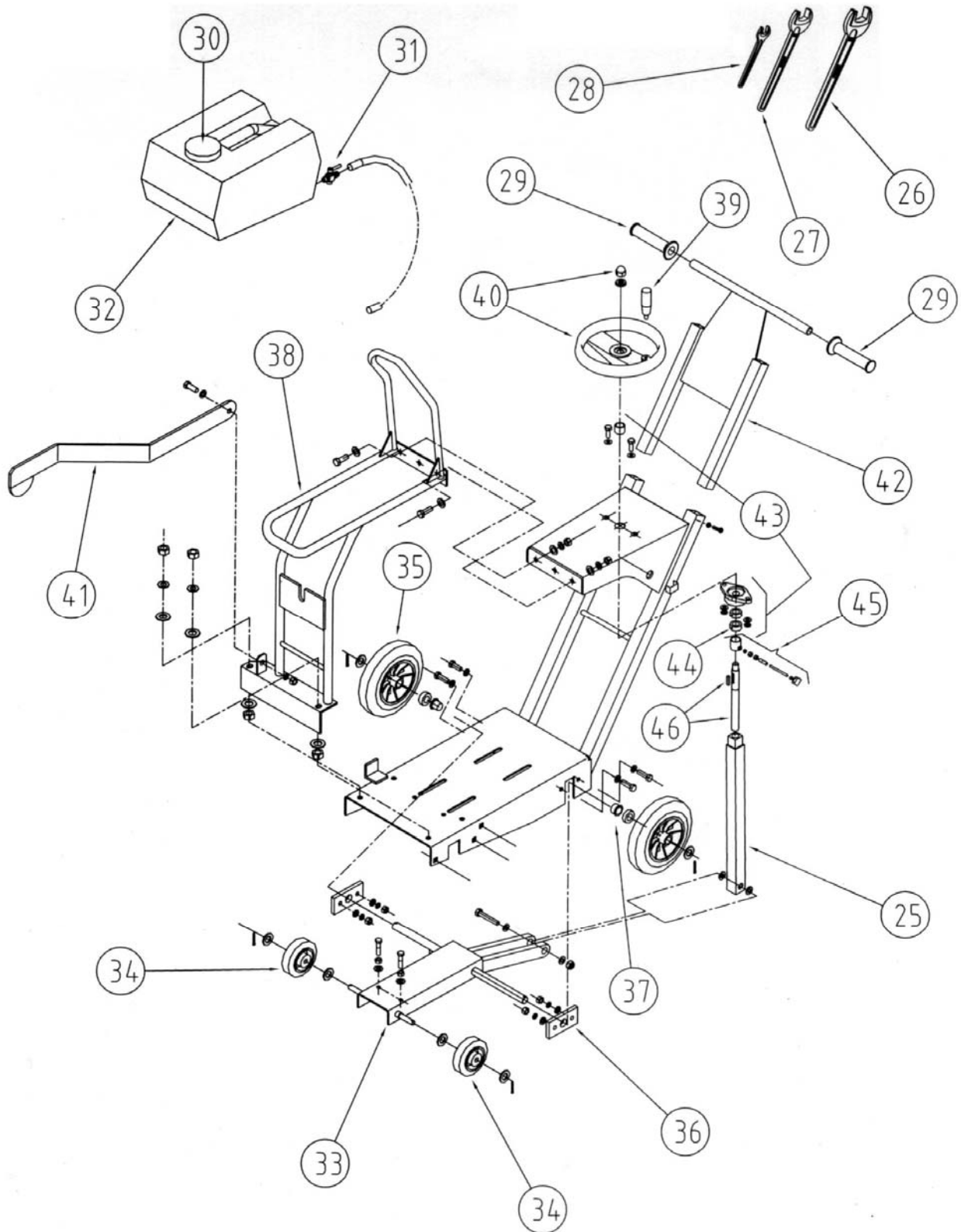

## Service Parts List C9

POS	Description	Req	P/N
1	Blade Shaft (Alone)	1	83280
2	Nut Blade Shaft ¾" Lefthand Thread	1	227156
3	Bearings Blade Shaft (1) with Hardware	2	72474
	Screw M12 x 70 1.75 DIN931 (ea)	2	27175
	Washer M12 DIN125 (ea)	16	27505
	Lock Washer M12 DIN127 (ea)	8	27581
	Nut M12 1.75 DIN934 (ea)	4	27007
	Screw M12 x 45 1.75 DIN933 (ea)	2	27088
4	Blade Shaft Pulley	1	83511
5	Collar Tight (Inner Collar)	1	227159
6	Collar Loose Assembly (With Pin)	1	227247
7	Belts XPA 710 LW (Set of 3)	1	83480
8	Belt Guard Complete	1	83485
	Screw M10 x 25 1.5 DIN931 (ea)	3	149044
	Washer M10 DIN125 (ea)	5	27504
	Lock Washer M10 DIN125 (ea)	3	27502
	Nut M10 1.5 DIN934 (ea)	3	27006
	Cage Nut M10 1.5 (ea)	3	27189
	Nut Close M10 Hex Acorn Nut (ea)	2	30177A
	Washer M10 DIN125 (ea)		27504
9	Blade Guard Flap w/Hardware	1	81164
	Screw M10 x 25 1.5 DIN933 (ea)	2	149044
	Washer M10 Large Dia DIN9021 (ea)	2	27504A
	Washer M10 DIN125 (ea)	2	27504
	Nut M10 1.5 DIN934 (ea)	2	27006
10	Blade Guard Complete w/Hardware	1	83481
	Screw M10 x 35 1.5 DIN933 (ea)	1	27030A
	Nut M10 1.5 DIN934 (ea)	1	27006
11	Stop Switch	1	227115
12	Belt Tensioning Screws (Compelte Set)	1	80994
	Screw M10 x 80 1.5 DIN931 (ea)	2	27068
	Eye Bolt M10 x 40 1.5 DIN444 (ea)	2	27270
	Nut M10 Thin 1.5 DIN439 (ea)	2	27004
	Nut M10 1.5 DIN934 (ea)	6	27006
	Lock Washer M10 DIN127 (ea)	4	27502
	Washer M10 DIN125 (ea)	6	27504
13	Engine Frame Welded (No Hardware)	1	83279
14	Motor Pulley Complete	1	73230
15	Honda Motor 9 HP GX270	1	73110
16	Y piece	1	72286
17	Adapter ½ Hose Barb to ¾" Garden Hose	1	232076
18	Motor Fixing Plate w/Hardware	1	83482
	Nut M10 1.5 DIN934 (ea)	8	27006
	Lock Washer M10 DIN127 (ea)	8	27502
	Washer M10 DIN125 (ea)	4	27504
	Washer M10 Large Dia DIN9021 (ea)	4	27504A
19	Water Nozzle (2)	1	82998
20	Axle Blade Guard	1	83490
21	Blade Guard Nut	1	83366
22	Valve Ball 1/2" Brass	1	107859
23	Fit 1/2mpt X3/4 F Garden Hose Swivel	1	227116

## Service Parts List C9

POS	Description	Req	P/N
24	Fit Barb Hose 3/4MPT X 1/2M	1	9600017
25	RaiseTube (No Hardware)	1	83276
	Screw M12 x 80 1.75 DIN933 (ea)	1	27088
	Nut Lock M12 1.75 DIN985 (ea)	2	27017
	Nut M12 1.75 DIN934 (ea)	4	27581
26	Wrench 1"1/2	1	83314
27	Wrench 32mm	1	82910
28	Wrench 17mm	1	72279
29	Handle Grip (ea)	2	213633
30	Tank Cap	1	82794
31	Tap-Water Tank	1	72357
32	Water Tank Complete w/Cap	1	83357
33	Raise Axle w/Hardware	1	83486
	Screw M10 x 60 1.5 DIN931 (ea)	2	27030B
	Nut M10 1.5 DIN934 (ea)	2	27006
34	Front Wheel Complete (ea)	2	80992
	Washer M16 DIN127 (ea)	4	27532
	Pin Cotter 5/32 x 1 (ea)	2	27030C
35	Rear Wheel 200mm x 20mm (ea)	2	80991
	Washer M20 DIN125 (ea)	2	27504B
	Pin Cotter 5/32 x 1-1/2 (ea)	2	27030D
36	Rear Axle Fixing Flat (ea)	2	80998
	Screw M10 x 30 1.5 DIN933 (ea)	4	27030
	Nut M10 1.5 DIN934 (ea)	4	27006
	Lock Washer M10 DIN125 (ea)	4	27502
	Washer M10 DIN125 (ea)	8	27504
37	Ring Diam. 20	1	80999
38	Water Tank Bracket w/Hardware	1	83277
	Screw M10 x 25 1.5 DIN933 (ea)	2	149044
	Nut M10 1.5 DIN934 (ea)	2	27006
	Lock Washer M10 DIN125 (ea)	2	27502
	Washer M10 DIN125 (ea)	4	27504
39	Handle For Hand Wheel (No Hardware)	1	73428
40	Hand Wheel with Handle and Hardware	1	76357
	Nut Closed M16 2 DIN1587 (1)	1	27176
	Washer M16 DIN125 (1)	1	27532
	Lock Washer M16 DIN127 (1)	1	27545
41	Guide-A-Cut	1	80448
42	Handle Bar Complete w/Hardware	1	83484
	Screw M10 x 25 1.5 DIN933 (ea)	1	149044
	Screw M10 x 20 1.5 DIN933 (ea)	1	27106
	Nut M10 1.5 DIN934 (ea)	2	27006
43	Bearing w/Hardware	1	76670
	Screw M10 x 30 1.5 DIN933 (ea)	2	27030
	Nut M10 1.5 DIN934 (ea)	2	27006
	Lock Washer M10 DIN125 (ea)	2	27502
	Washer M10 DIN125 (ea)	4	27504
44	Stop Ring A20	1	82789
45	Depth Lock	1	83354
46	Depth Screw w/Key	1	82788

# NOTES

## **Norton Construction Products**

**PO Box 2898**

**Gainesville, GA 30503**

Phone: 800-554-8003 or 770-967-3954

(8:00 A.M. to 7:00 P.M. Eastern Time)

Fax: 800-443-1092 or 770-967-7287

# ***clipper***

*A PRODUCT OF NORTON COMPANY*

**NORTON**

# **WARNING**

**Some dust created by power sanding, sawing, grinding, drilling, and other construction activities contains chemicals known to cause cancer, birth defects or other reproductive harm. Some examples of these chemicals are:**

- **Lead from lead-based paints,**
- **Crystalline silica from bricks and cement and other masonry products, and**
- **Arsenic and chromium from chemically-treated lumber.**

**Your risk from these exposures varies, depending on how often you do this type of work. To reduce your exposure to these chemicals: work in a well ventilated area, and work with approved safety equipment, such as those dust masks that are specially designed to filter out microscopic particles.**