

# **OPERATION AND PARTS MANUAL**



## **MODEL GA-6H/GA-6HA** **Portable Generators** **(HONDA GASOLINE ENGINE)**

Revision #0 (06/02/05)

**THIS MANUAL MUST ACCOMPANY  
THE EQUIPMENT AT ALL TIMES.**

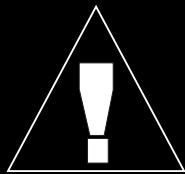

# WARNING

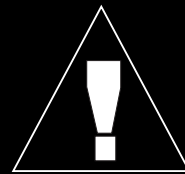

## **CALIFORNIA — Proposition 65 Warning**

Engine exhaust and some of its constituents are known to the State of California to cause cancer, birth defects and other reproductive harm.

## **HERE'S HOW TO GET HELP**

PLEASE HAVE THE MODEL AND SERIAL  
NUMBER *ON-HAND* WHEN CALLING

### **MULTIQUIP CORPORATE OFFICE**

18910 Wilmington Ave.

800-421-1244

Carson, CA 90746

FAX: 310-537-3927

Email: [mq@multiquip.com](mailto:mq@multiquip.com)

Internet: [www.multiquip.com](http://www.multiquip.com)

### **PARTS DEPARTMENT**

800-427-1244

FAX: 800-672-7877

310-537-3700

FAX: 310-637-3284

### **MAYCO PARTS**

800-306-2926

FAX: 800-672-7877

310-537-3700

FAX: 310-637-3284

### **SERVICE DEPARTMENT**

800-421-1244

FAX: 310-537-4259

310-537-3700

### **TECHNICAL ASSISTANCE**

800-478-1244

FAX: 310-631-5032

### **WARRANTY DEPARTMENT**

800-421-1244, EXT. 279

FAX: 310-537-1173

310-537-3700, EXT. 279

© COPYRIGHT 2005, MULTIQUIP INC.

Multiquip Inc, the MQ logo are registered trademarks of Multiquip Inc. and may not be used, reproduced, or altered without written permission. All other trademarks are the property of their respective owners and used with permission.

This manual **MUST** accompany the equipment at all times. This manual is considered a permanent part of the equipment and should remain with the unit if resold.

The information and specifications included in this publication were in effect at the time of approval for printing. Illustrations are based on the *MQ GA-6H/GA-6HA Portable Generators*. Illustrations, descriptions, references and technical data contained in this manual are for guidance only and may not be considered as binding. Multiquip Inc. reserves the right to discontinue or change specifications, design or the information published in this publication at any time without notice and without incurring any obligations.

To find the latest revision of this  
publication, visit our website at:  
[www.multiquip.com](http://www.multiquip.com)



## Multiquip GA-6H/GA-6HA AC Portable Generators

|   |       |
|---|-------|
| Here's How To Get Help .....                | 3     |
| Table Of Contents .....                     | 4     |
| Parts Ordering Procedures .....             | 5     |
| Safety Message Alert Symbols .....          | 6-7   |
| Rules for Safe Operation .....              | 8-10  |
| Operation and Safety Decals .....           | 11    |
| Specifications (Generator) .....            | 12    |
| Specifications (Engine) .....               | 13    |
| Dimensions .....                            | 14    |
| General Information .....                   | 15    |
| Load Application .....                      | 16    |
| Controls and Indicators .....               | 17-19 |
| Generators Refueling .....                  | 20    |
| Installation .....                          | 21-22 |
| Pre-Inspection .....                        | 23    |
| Pre-Inspection (Engine) .....               | 24    |
| Initial Start-up (Engine) .....             | 25    |
| Initial Start-up/Generators Operation ..... | 26    |
| Generators Operation/Shutdown .....         | 27    |
| Preparation For Long Term Storage .....     | 28    |
| Maintenance (Engine) .....                  | 30-31 |
| Wiring Diagram (GA-6H Generator) .....      | 32    |
| Wiring Diagram (GA-6HA Generator) .....     | 33    |
| Troubleshooting (Engine) .....              | 34-35 |
| Troubleshooting (Generator) .....           | 36    |
| Explanation of Code In Remarks Column ..... | 38    |
| Suggested Spare Parts .....                 | 39    |

## HONDA GX340K1EDN2 ENGINE

|                                |       |
|--------------------------------|-------|
| Air Cleaner Assembly .....     | 52-53 |
| Camshaft Assembly .....        | 54-55 |
| Carburetor Assembly .....      | 56-57 |
| Control Assembly .....         | 58-59 |
| Crankcase Cover Assembly ..... | 60-61 |
| Crankshaft Assembly .....      | 62-63 |
| Cylinder Barrel Assembly ..... | 64-65 |
| Cylinder Head Assembly .....   | 66-67 |
| Fan Cover Assembly .....       | 68-69 |
| Flywheel Assembly .....        | 70-71 |
| Ignition Coil Assembly .....   | 72-73 |
| Piston Assembly .....          | 74-75 |
| Recoil Starter Assembly .....  | 76-77 |
| Solenoid Assembly .....        | 78-79 |
| Label Assembly .....           | 80-81 |

|  |    |
|--|----|
| Terms and Conditions Of Sale — Parts ..... | 82 |
|--|----|

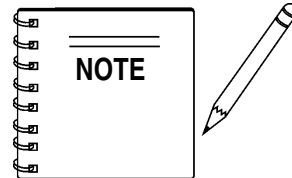

***Specification and part number are subject to change without notice.***

## Component Drawings

|                                     |       |
|-------------------------------------|-------|
| Nameplate and Decals .....          | 40-41 |
| Generators Assembly .....           | 42-43 |
| Control Box Assembly (GA-6H) .....  | 44-45 |
| Control Box Assembly (GA-6HA) ..... | 46-47 |
| Muffler Assembly .....              | 48-49 |
| Pipe Frame Assembly .....           | 50-51 |

# PARTS ORDERING PROCEDURES

## When ordering parts, please supply the following information:

- Dealer account number
- Dealer name and address
- Shipping address (if different than billing address)
- Return fax number
- Applicable model number
- Quantity, part number and description of each part
- Specify preferred method of shipment:
  - ✓ FedEx or UPS Ground
  - ✓ FedEx or UPS Second Day or Third Day
  - ✓ FedEx or UPS Next Day
  - ✓ Federal Express Priority One
  - ✓ DHL
  - ✓ Truck

*Note: Unless otherwise indicated by customer, all orders are treated as "Standard Orders", and will ship within 24 hours. We will make every effort to ship "Air Shipments" the same day that the order is received, if prior to 2PM west coast time. "Stock Orders" must be so noted on fax or web forms.*



## Here's how to get help...

*Please have the model and serial number on hand when calling.*

### MULTIQUIP CORPORATE OFFICE

18910 Wilmington Ave. 800-421-1244  
 Carson, CA 90746 FAX: 310-537-3927  
 Email: mq@multiquip.com  
 Internet: www.multiquip.com

### PARTS DEPARTMENT

800-427-1244 FAX: 800-672-7877  
 310-537-3700 FAX: 310-637-3284

### MAYCO PARTS

800-306-2926 FAX: 800-672-7877  
 310-537-3700 FAX: 310-637-3284

### SERVICE DEPARTMENT

800-421-1244 FAX: 310-537-4259  
 310-537-3700

### TECHNICAL ASSISTANCE

800-478-1244 FAX: 310-631-5032

### WARRANTY DEPARTMENT

800-421-1244, EXT. 279 FAX: 310-537-1173  
 310-537-3700, EXT. 279

## Place Your Parts Order Via Web or Fax For Even More Savings!

*(Domestic USA Dealers Only)*

### Extra Discounts!

All parts orders which include complete part numbers and are received by our automated web parts order system, or by fax qualify for the following extra discounts:

| Ordered via | Standard orders | Stock orders (\$750 list and above) |
|-------------|-----------------|-------------------------------------|
| Fax         | 3%              | 10%                                 |
| Web         | 5%              | 10%                                 |

### Special freight allowances when you order 10 or more line items via Web or Fax! \*\*

FedEx Ground Service *at no charge for freight*

*No other allowances on freight shipped by any other carrier.*

*\*\*Common nuts, bolts and washers (all items under \$1.00 list price) do not count towards the 10+ line items.*

NOTE: DISCOUNTS ARE SUBJECT TO CHANGE



**MULTIQUIP INC.**  
 18910 WILMINGTON AVENUE  
 POST OFFICE BOX 6254  
 CARSON, CALIFORNIA 90749  
 310-537-3700 • 800-421-1244  
 FAX: 310-537-3927  
 E-MAIL: mq@multiquip.com  
 INTERNET: www.multiquip.com

## Direct TOLL-FREE access to our Parts Department:

Toll-free nationwide — 800-427-1244  
 Toll-free FAX — 800-6-PARTS-7 (800/672-7877)

# GA-6H/GA-6HA — SAFETY MESSAGE ALERT SYMBOLS

## FOR YOUR SAFETY AND THE SAFETY OF OTHERS!

Safety precautions should be followed at all times when operating this equipment. Failure to read and understand the Safety Messages and Operating Instructions could result in injury to yourself and others.

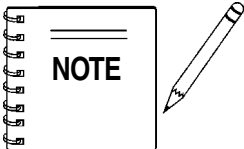

This Owner's Manual has been developed to provide complete instructions for the safe and efficient operation of the MQ Model GA-6H/GA-6HA Portable Generators. Refer to the engine manufacturers instructions for data relative to its safe operation.

**Before using these generators, ensure that the operating individual has read and understands all instructions in this manual.**

## SAFETY MESSAGE ALERT SYMBOLS

The three (3) Safety Messages shown below will inform you about potential hazards that could injure you or others. The Safety Messages specifically address the level of exposure to the operator, and are preceded by one of three words: **DANGER**,

### **DANGER**

You **WILL** be **KILLED** or **SERIOUSLY INJURED** if you **DO NOT** follow these directions.

### **WARNING**

You **CAN** be **KILLED** or **SERIOUSLY INJURED** if you **DO NOT** follow these directions.

### **CAUTION**

You **CAN** be **INJURED** if you **DO NOT** follow these directions.

## HAZARD SYMBOLS

Potential hazards associated with the operation of a **GA-6H/GA-6HA Portable Generators** will be referenced with Hazard Symbols which appear throughout this manual, and will be referenced in conjunction with Safety Message Alert Symbols.

### **WARNING**

#### Lethal Exhaust Gas Hazards

Engine exhaust gases contain poisonous carbon monoxide. This gas is colorless and odorless, and can cause death if inhaled. **NEVER** operate this equipment in a confined area or enclosed structure that does not provide ample free flow air.



### **WARNING**

#### Explosive Fuel Hazards

**Gasoline** is extremely flammable, and its vapors can cause an explosion if ignited. **DO NOT** start the engine near spilled fuel or combustible fluids.



**DO NOT** fill the fuel tank while the engine is running or hot. **DO NOT** overfill tank, since spilled fuel could ignite if it comes into contact with hot engine parts or sparks from the ignition system. Store fuel in approved containers, in well-ventilated areas and away from sparks and flames.

### **WARNING**

#### Burn Hazards

Engine components can generate extreme heat. To prevent burns, **DO NOT** touch these areas while the engine is running or immediately after operations. Never operate the engine with heat shields or heat guards removed.



### **WARNING**

#### Respiratory Hazards

**ALWAYS** wear approved **respiratory** protection when required.



## GA-6H/GA-6HA — SAFETY MESSAGE ALERT SYMBOLS

### CAUTION

#### Rotating Parts Hazards

**NEVER** operate equipment with covers, or guards removed. Keep fingers, hands, hair and clothing away from all moving parts to prevent injury.



### CAUTION

#### Equipment Damage Hazards

Other important messages are provided throughout this manual to help prevent damage to your portable generator, other property, or the surrounding environment.

### CAUTION

#### Accidental Starting Hazards

**ALWAYS** place the power source, circuit breakers or **ON/OFF** switch in the **OFF** position, when the generator is not in use, unless connected to transfer switch.



### CAUTION

#### Eye and Hearing Hazards

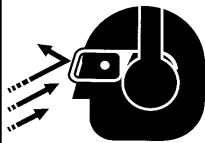

**ALWAYS** wear approved eye and hearing protection.

# GA-6H/GA-6HA — RULES FOR SAFE OPERATION

## DANGER

### Read this manual!

Failure to follow instructions in this manual may lead to serious injury or even death! This equipment is to be operated by trained and qualified personnel only! This equipment is for industrial use only.

The following safety guidelines should always be used when operating the GA-6H/GA-6HA Portable Generator:

### GENERAL SAFETY

■ **DO NOT** operate or service this equipment before reading this entire manual.



■ This equipment should not be operated by persons under 18 years of age.

■ **NEVER** operate this equipment without proper protective clothing, shatterproof glasses, steel-toed boots and other protective devices required by the job.



■ **NEVER** operate this equipment when not feeling well due to fatigue, illness or taking medicine.



■ **NEVER** operate this equipment under the influence of **drugs** or **alcohol**.



■ **ALWAYS** wear proper respiratory (mask), hearing and eye protection equipment when operating the generator.



■ Whenever necessary, replace nameplate, operation and safety decals when they become difficult read.

■ Manufacturer does not assume responsibility for any accident due to equipment modifications.

■ **NEVER** use accessories or attachments, which are not recommended by Multiquip for this equipment. Damage to the equipment and/or injury to user may result.

■ **NEVER** touch the hot exhaust manifold, muffler or cylinder. Allow these parts to cool before servicing engine or generators.



■ The engine section of this generators requires an adequate free flow of cooling air. **NEVER** operate the generators in any enclosed or narrow area where free flow of the air is restricted. If the air flow is restricted it will cause serious damage to the generators or engine and may cause injury to people. Remember the generator's engine gives off **DEADLY** carbon monoxide gas.

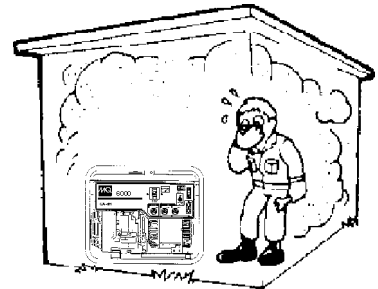

■ **ALWAYS** refuel in a well-ventilated area, away from sparks and open flames.

■ **ALWAYS** use extreme caution when working with **flammable** liquids. When refueling, **stop the engine** and allow it to cool. **DO NOT smoke** around or near the machine. Fire or explosion could result from fuel vapors, or if fuel is spilled on a hot engine.



■ **NEVER** operate the generators in an explosive atmosphere or near combustible materials. An explosion or fire could result causing severe **bodily harm or even death**.

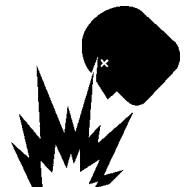

■ **NEVER** disconnect any "**emergency or safety devices**". These devices are intended for operator safety. Disconnection of these devices can cause severe injury, bodily harm or even death! Disconnection of any of these devices will void all warranties.



# GA-6H/GA-6HA — RULES FOR SAFE OPERATION

- **ALWAYS** be sure the operator is familiar with proper safety precautions and operation techniques before using generators.
- **NEVER** leave the generators unattended, turn off engine when unattended.
- Unauthorized equipment modifications will void all warranties.
- **ALWAYS** ensure generators are on level ground before use.
- **DO NOT** place hands or fingers inside generators engine compartment when engine is running.
- **NEVER** run engine without air cleaner. Severe engine damage may occur.
- **NEVER** change or adjust the engine speed which has been set at the factory prior to shipping.

## Power Cord Safety

- **NEVER** let power cables or cords *lay in water*.
- **NEVER** *stand in water* while AC power from the generators is being transfer to a load.
- **NEVER** use a defective or frayed power cable. Check the cable for cuts in the insulation.
- **NEVER** use a extension cord that is frayed or damaged where the insulation has been cut.
- **ALWAYS** make certain that proper power or extension cord has been selected for the job See Table 4.

## Grounding Safety

- **ALWAYS** make sure that electrical circuits are properly *grounded* per the **National Electrical Code** (NEC) and local codes before operating generator. Severe *injury* or *death!* by electrocution can result from operating an ungrounded generator.
- **ALWAYS** make sure the generators are properly grounded to a suitable earth ground (**GROUND ROD**). See installation in this manual.
- **NEVER** use *gas piping* as an electrical ground.

## Maintenance Safety

- **NEVER** lubricate components or attempt service on a running machine.
- **High Temperatures** – Always stop engine and allow the engine to cool before adding fuel, oil or performing service and maintenance functions. Contact with **hot!** components can cause serious burns.
- Keep the machinery in proper running condition.
- Fix damage to the machine immediately and replace any broken parts immediately.
- **ALWAYS** replace any worn or damaged warning decals.
- **ALWAYS** store equipment properly when it is not being used. Equipment should be stored in a clean, dry location out of the reach of children and un-authorized personnel.
- The electrical voltage required to operate the generators can cause severe injury or even death through physical contact with live circuits. Turn all circuit breakers **OFF** before performing maintenance on the generator.
- Dispose of hazardous waste properly. Examples of potentially hazardous waste are used motor oil, fuel and fuel filters.
- **DO NOT** use food or plastic containers to dispose of hazardous waste.
- **DO NOT** pour waste, oil or fuel directly onto the ground, down a drain or into any water source.
- Removing the engine oil drain plug while the engine is hot will result in hot oil to gush out of the oil drain plug, therefore causing severe scalding to any persons in the general area of the generator.



## DANGER-ELECTROCUTION HAZARDS

During operation of this generation, there exists the possibility of **electrocution, electrical shock or burn**, which can cause **severe bodily harm** or even **DEATH!**



To avoid these hazards:

**NEVER** use **damaged** or **worn** cables when connecting equipment to the generator. Make sure power connecting cables are securely connected to the generator's output receptacles, incorrect connections may cause damage to the generators and electrical shock.

**NEVER** grab or touch a live power cord with wet hands, the possibility exist of electrical shock, electrocution, and even **death!**

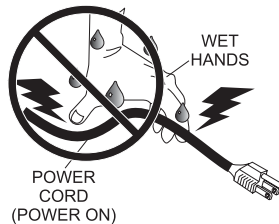

**NEVER** insert any objects into the output receptacles during operation. This is extremely dangerous. **ALWAYS** turn-off the generators and place all circuit breakers in the "OFF" position when contact with the output receptacles is required. There exist the possibility of **electrocution, electrical shock or burn, which can cause severe bodily harm or even death!**

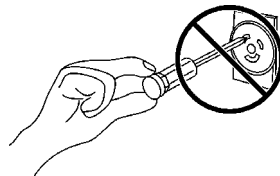

Backfeed to a utility system can cause **electrocution** and or property damage. **NEVER** connect the generators to a building's electrical system without a transfer switch or other approved device. All installations should be performed by a **licensed electrician** in accordance with all applicable laws and electrical codes. Failure to do so could result in electrical shock or burn causing serious injury or even death!

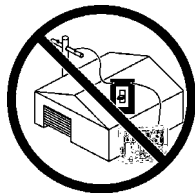

## Emergencies

■ **ALWAYS** know the location of the nearest **fire extinguisher**.

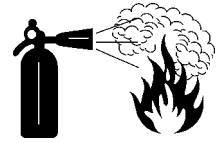

■ **ALWAYS** know the location of the nearest **first aid kit**.



■ In emergencies **always** know the location of the nearest phone or **keep a phone on the job site**. Also know the phone numbers of the nearest **ambulance, doctor** and **fire department**. This information will be invaluable in the case of an emergency.

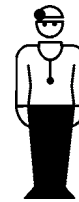
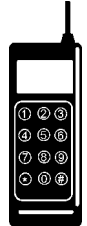

# GA-6H/GA-6HA — OPERATION AND SAFETY DECALS

## Machine Safety Decals

The GA-6H/GA-6HA portable generators are equipped with a number of safety decals (Figure 1). These decals are provided for operator safety and maintenance information. The illustration below shows these decals as they appear on the machine. Should any of these decals become unreadable, replacements can be obtained from your dealer.

**MQ MULTIQIP 6000**

P/N A556100003



P/N 8700611804

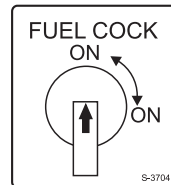

P/N 1980680004



CONTACT  
MQ PARTS DEPT.

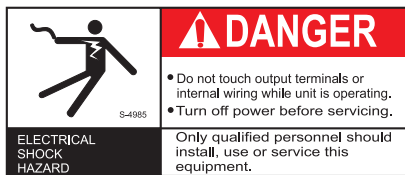

P/N 8700611904



P/N 0800628504

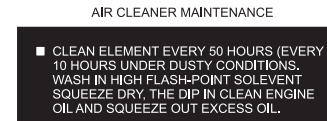

P/N 060050045



P/N 7900636004

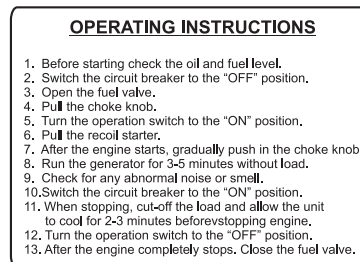

P/N A9521200104



P/N 35137

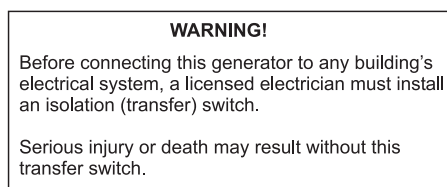

P/N 0820610404

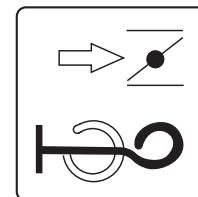

P/N 0600500047

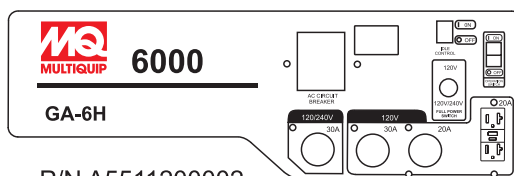

P/N A5511200002

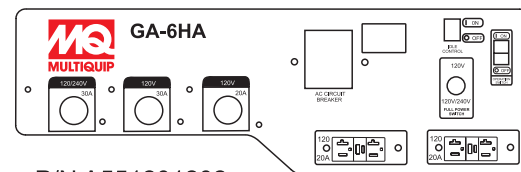

P/N A551201202

Figure 1. Operation and Safety Decals

# GA-6H/GA-6HA — SPECIFICATIONS (GENERATORS)

## Table 1. Specifications (Generators)

|                                   |  |  |
|-----------------------------------|--|--|
| <b>AC Generator</b>               | Model  | GA-6H/GA-6HA                           |
|                                   | Type   | Brushless Revolving Field Type         |
|                                   | Excitation                                     | Solid State, Statically Excited System |
|                                   | Speed  | 3,600 RPM                              |
|                                   | Cooling System                                 | Self-Ventilation                       |
|                                   | Fuel Capacity                                  | 5 gallons (19 liters)                  |
| <b>60 Cycle AC Power Source</b>   | Continuous Output                              | 5.0 kW                                 |
|                                   | Standby Output                                 | 6.0 kW                                 |
|                                   | Rated Voltage                                  | 120/240V                               |
|                                   | Current Max/Continuous (120V)                  | 50.0/41.6 amps                         |
|                                   | Current Max/Continuous (240V)                  | 25.0/20.8 amps                         |
|                                   | Phase  | Single Phase (4 wire)                  |
|                                   | Frequency                                      | 60 Hz                                  |
|                                   | Power Factor                                   | 1                                      |
| <b>Dimensions<br/>(L x W x H)</b> | 25.6 x 22.6 X 21.3 in.<br>(650 X 560 X 540 mm) |  |
| <b>Dry Net Weight</b>             | 201 lbs. (91 kg.)                              |  |
| <b>Weight (With Fuel)</b>         | 227 lbs. (103 kg.)                             |  |

### Effects of Altitude and Heat

The maximum output of the engines listed above are applicable to supplying electrical power for continuous service at ambient conditions in accordance with SAE Test cord J607. The above ambient conditions are at standard sea level, with a barometric reading of 29.92 inches and a temperature of 60 degrees fahrenheit.

Generally, the engine's output power will decrease 3-1/2% for each 1000 feet of altitude above sea level, and 1% for each 10° F Fahrenheit above the standard temperature of 60° F

**Table 2. Specifications (Engine)**

|                              |                             |   |
|------------------------------|-----------------------------|---|
| <b>Engine</b>                | <b>Model</b>                | <b>HONDA GX340K1EDN2</b>  |
|                              | <b>Type</b>                 | Air-cooled 4 stroke, Single Cylinder, OHV, Horizontal Shaft Gasoline Engine |
|                              | <b>Bore X Stroke</b>        | 2.90 in. X 2.30 in.<br>(73 mm x 58 mm.)                                     |
|                              | <b>Displacement</b>         | 23.70 cu-in (389 cm <sup>3</sup> )  |
|                              | <b>Max Output</b>           | 11.0 H.P./3600 R.P.M.   |
|                              | <b>Fuel</b>                 | Unleaded Automobile Gasoline  |
|                              | <b>Lube Oil Capacity</b>    | 1.16 quarts (1.1 liters)  |
|                              | <b>Oil Alert System</b>     | Yes   |
|                              | <b>Speed Control Method</b> | Centrifugal Fly-weight Type   |
|                              | <b>Starting Method</b>      | Recoil Start  |
| <b>Dimension (L x W x H)</b> |                             | 15.0 x 17.7 X 17.4 in.<br>(380 X 450 X 443 mm.)                             |
| <b>Dry Net Weight</b>        |                             | 68.4 lbs (31 Kg.)   |

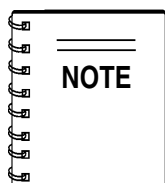

In keeping with Multiquip's policy of constantly improving its products, the specifications quoted herein are subject to change without prior notice.

# GA-6H/GA-6HA — DIMENSIONS

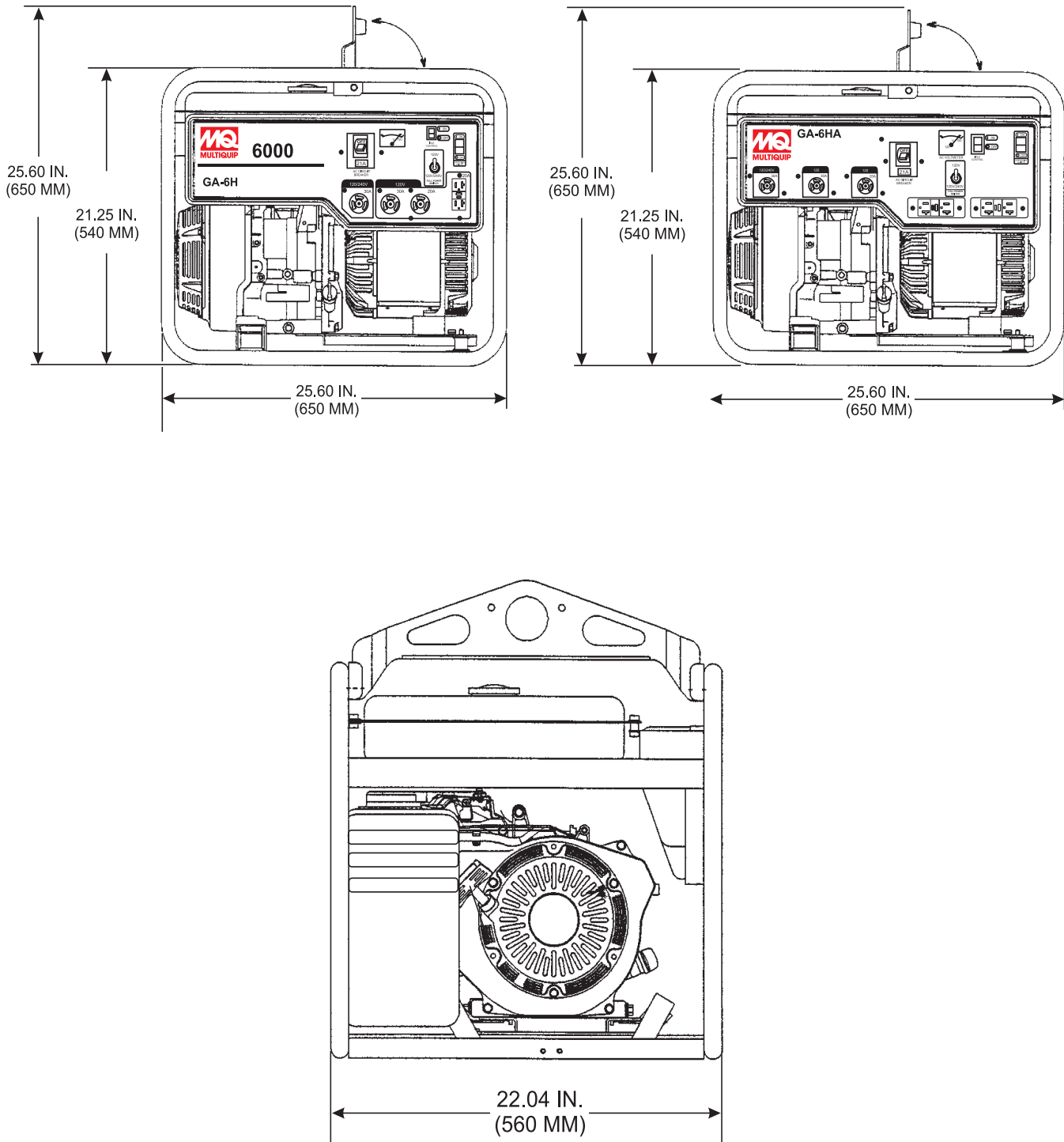

Figure 2. Dimensions

## **WARNING**

Before connecting this generators to any building's electrical system, a licensed electrician must install an isolation (transfer) switch.

Serious injury or death may result without this transfer switch.

## GA-6H/GA-6HA FAMILIARIZATION

### Generator

The Multiquip GA-6H and GA-6HA generators have been designed as a portable dual purpose power source for 60 Hz (single phase) lighting facilities, power tools, submersible pumps and other industrial and construction machinery.

These generators are mounted on rubber vibration isolators that have a steel base backplate which is attached to the protective steel pipe carrying frame. The protective carrying frame is made of steel tubing and fully wraps around the generators to protect against damage. See Figures 3A through 3E for the basic controls and indicators for the GA-6H/GA-6HA generators.

These portable generators are supplied with a electrical **control box**. To reduce vibration caused by the engine, the control box is also placed on rubber isolators.

### Control Box

The control box is provided with the following:

- 120/240V twist-lock output receptacle (single phase).
- 120V twist-lock receptacle (2) (single phase).
- 120V GFCI single phase duplex output receptacle (GA-6HA has two).
- 21 amp main circuit breaker.
- AC Voltmeter
- Ground Terminal
- Full Power Switch
- Idle Control Switch
- Operation Switch

### Excitation System

The GA-6H/GA-6HA-series generators use a magnet attached to a flywheel to produce AC voltage from a lamp coil beneath the flywheel. As the magnetic passes the coil it produces approximately 19-22 AC volts.

This voltage (19-22 VAC) is then sent to the control box that contains three rectifying diodes:

- Excitation (diode 1)
- Battery (diode 2)
- Slow Down (diode 3)

The AC voltage will pass through the excitation diode that converts the voltage to DC power.

This DC power is then sent to the excitation windings housed within the main windings commonly called the "stator".

This voltage is then transferred into the rotor through induction. The rotor contains two diodes within it which rectify the DC voltage and send it out through the main windings, as AC voltage.

### Alternator

The alternator, a brushless revolving-field type, is permanently aligned to the engine through rigid coupling.

### Engine

These generators are powered by a 11 HP, air-cooled, 4-stroke **HONDA** gasoline engine. Reference Table 2, for engine specifications.

# GA-6H/GA-6HA — LOAD APPLICATION

## Single Phase Load — 60 Hz

Always be sure to check the nameplate on the generators and equipment to insure the wattage, amperage and frequency requirements are satisfactorily supplied by the generators for operating the equipment.

Generally, the wattage listed on the nameplate of the equipment is its rated output. Equipment may require 130—150% more wattage than the rating on the nameplate, as the wattage is influenced by the efficiency, power factor and starting system of the equipment.

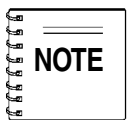

If wattage is not given on the equipment's name plate, approximate wattage may be determined by multiplying nameplate voltage by the nameplate amperage.

$$\text{WATTS} = \text{VOLTAGE} \times \text{AMPERAGE}$$

The power factor of this generators is 1.0 See Table 3 below when connecting loads.

**Table 3. Power Factor By Load**

| Type Of Load                                | Power Factor |
|---|--------------|
| Single-phase induction motors               | 0.4 - 0.75   |
| Electric heaters, incandescent lamps        | 1.0          |
| Fluorescent lamps, mercury lamps            | 0.4 - 0.9    |
| Electronic devices, communication equipment | 1.0          |
| Common power tools                          | 0.8          |

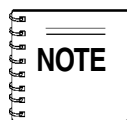

When using a combination of dual receptacles, total load **should not exceed** the rated capacity of the generator.

To determine the running wattage for your load, multiply the running wattage as indicated by steps 1, 2, and 3 below:

- INCANDESCENT LOADS**  
 Lights, heaters and similar appliances.  
 Total the running wattage and multiply by 1.  
 Example:  
 29 light bulbs @ 100W each = 2.9 KW  
 use a 3 KW generator.
- SMALL MOTORS**  
 Drills and other small power tools.  
 Total the running wattage and multiply by 2.  
 Example:  
 A 1 inch drill runs at 1 KW  
 use a 2 KW generator.
- LARGE MOTORS**  
 Submersible pumps, table saws etc.  
 Total the running wattage and multiply by 3.  
 Example:  
 A conveyor belt runs at 8 KW  
 use a 24 KW generator.

## CAUTION

Motors and motor-driven equipment draw much greater current for starting than during operation. **Always** use an adequate size **extension cable** which can carry the required load.

### Extension Cables

When electric power is to be provided to various tools or loads at some **distance** from the generator, extension cords are normally used. **Cables should be sized to allow for distance in length and amperage so that the voltage drop between the generators and point of use (load) is held to a minimum.** Use the cable selection chart (Tables 4 and 5) as a guide for selecting proper cable size.

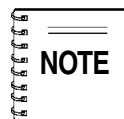

The idle control device is operated at a minimum load capacity of 100W. If the load capacity is less than 100W, place the idle control switch in the **OFF** position.



# GA-6H/GA-6HA — CONTROLS AND INDICATORS

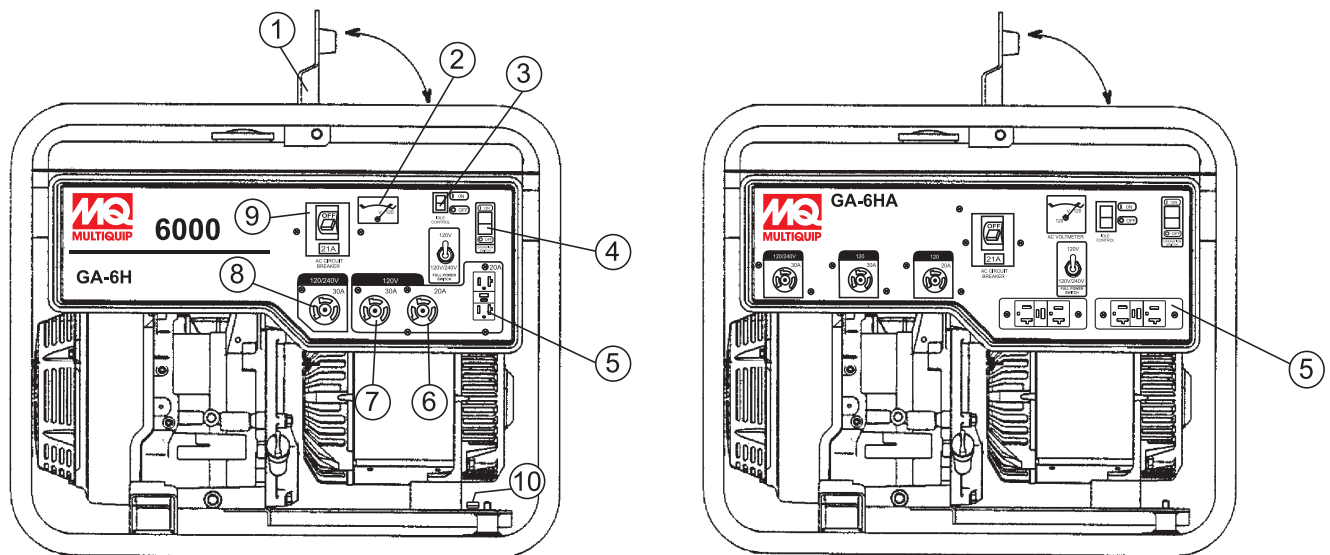

**Figure 3A. Generators Components**

1. **Lifting Bail Eye** – Attach a rope or chain to this lifting eye when lifting of the generators is required. Never stand underneath the generators while it is being lifted. Place lifting eye in down position when not in use.
2. **AC-Voltmeter** – This voltmeter indicates (with a mark) the rated 60 Hz (single-phase) output voltage. In addition the voltmeter can also be used as a diagnostic tool. If the voltmeter indicator (needle) is below the rated voltage, engine problems may exist (low/high RPM's). To prevent damage to the generators or power tools turn the generators **OFF** and consult your authorized Multiquip service dealer.
3. **Idle Control Switch** – The generators are provided with an automatic idle control device for noise suppression and reduced fuel consumption. The automatic idle control automatically engages under a no-load condition. With the automatic idle control switched "ON", the engine revolutions will automatically drop to about 2600 rpm (low-speed operation) within 3 seconds after the load stops. When the operation is resumed, the engine speed is automatically increased to about 3600 rpm (high-speed operation) as soon as the load is connected.
4. **Operation Switch** – Place this *rocker* switch in the "ON" position (up) for normal operation. To turn-off the generators, place the operation switch in the "OFF" position (down).
5. **GFCI Duplex Receptacle** – NEMA 5-20R, GFCI receptacle will provide 120V, 20 amps. (GA-6HA has two.)
6. **120V Output Receptacle** – NEMA L5-20R twist-lock receptacle will provide 120V, 20 amps, 60 Hz.
7. **120V Output Receptacle** – NEMA L5-30R twist-lock receptacle will provide 120V, 30 amps, 60 Hz.
8. **120V/240V Output Receptacle** – NEMA L14-30R twist-lock receptacle will provide (120V, 50 amps, or 240V, 25 amps, 60 Hz.)
9. **Main Breaker** – This 2-pole circuit breaker (120/240V, 21 amps) protects the generators from short circuiting or overloading. When starting the generators **always** have the circuit breaker placed in the "OFF" position.
10. **Ground** – This ground connection point should be connect to a good earth ground (ground rod)

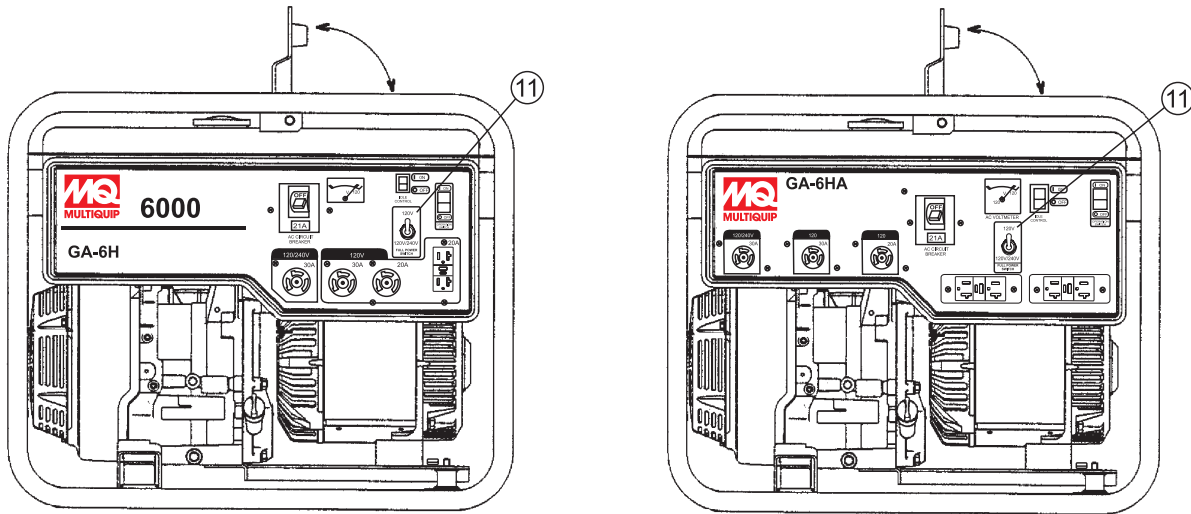
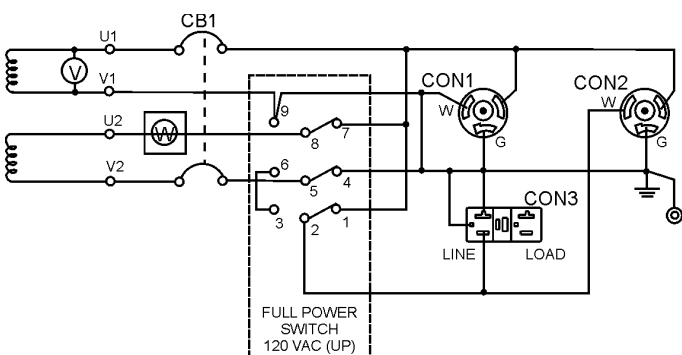

**Figure 3B. Generators Components**

11. **Full Power Switch** – The generators are provided with a full power switch. Figures 3C and 3D show simplified wiring diagrams of the dual voltage system.

When the full power switch is in the 120 volt (up) position, you can access the **full rated power** of the generators at 120 volts from the GFCI duplex receptacle and the 120V twist-lock receptacle, or a combination of both receptacles as long as the total load does not exceed the generating set capacity.

When the switch is in the 240 volt (down) position, you can access **half of the rated power** of the generating set at 120 volts from the GFCI duplex receptacle and up to half of the rated power of the set at 120 volts from 120V twist-lock receptacle; or full rated power of the set at 240 volts from the 240V twist-lock receptacle.



**Figure 3C. 120V Full Power Switch Simplified Diagram (Up Position)**

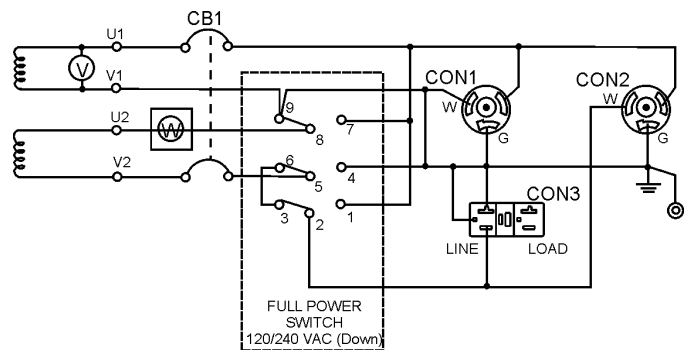

**Figure 3D. 120/240V Full Power Switch Simplified Diagram (Down Position)**

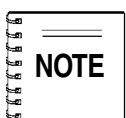

When the **full power switch** is in the 120V position, the 240V twist-lock receptacle **cannot be used**.

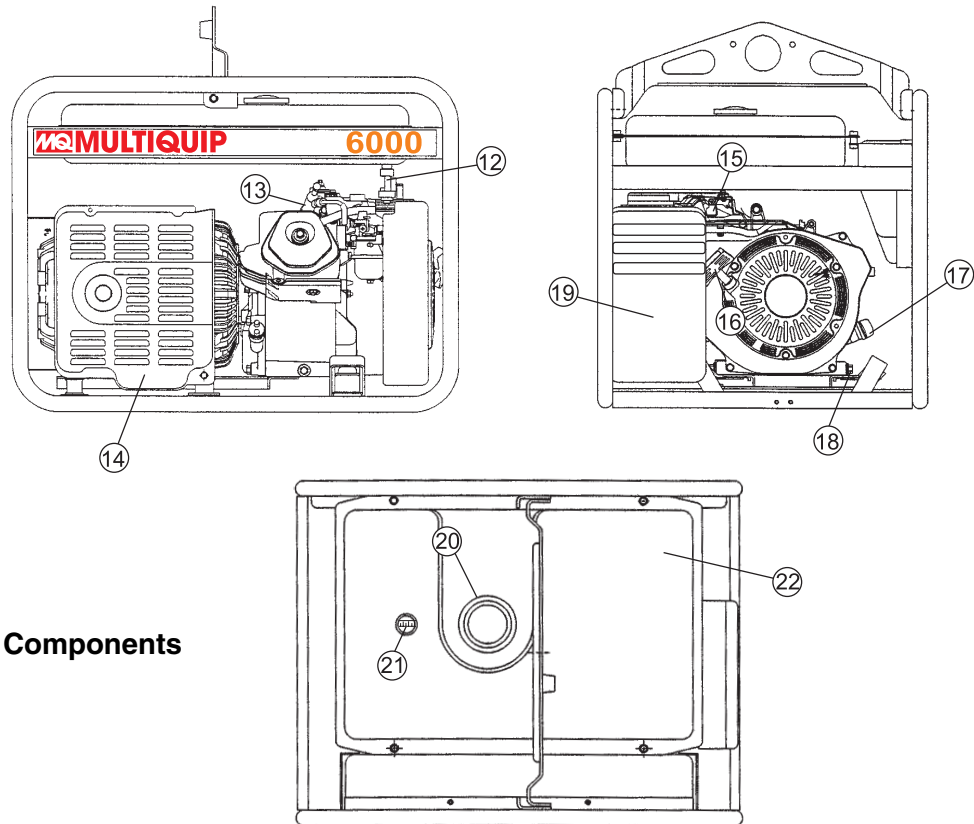

**Figure 3E. Generators Components**

12. **Fuel Cock Lever** – Turn this lever **downward** to **start** (down) the flow of fuel into the carburetor. Turn **upward** to **stop** (up) the flow of fuel.
13. **Spark Plug** – Provides spark to the ignition system. Set spark plug gap to 0.6 - 0.7 mm (0.028 - 0.031 inch) Clean spark plug once a week.
14. **Muffler/Heat Shield** – Used to reduce noise and emissions. **NEVER** touch this **heat shield** when the generator/welder is in use. Always allow time for the generators to cool down before performing maintenance.
15. **Choke Lever** – Used for starting the engine. **Close** the choke lever when starting a cold engine or in cold weather conditions. The choke enriches the fuel mixture. **Open** the choke lever if starting a warm engine or in warm weather conditions.
16. **Recoil Starter (pull rope)** – Manual-starting method. Pull the starter grip until resistance is felt, then pull briskly and smoothly.
17. **Engine Oil Filler Cap** – Remove this cap/dipstick when the adding of engine oil is required. See Table 5 for recommended type engine oil.
18. **Engine Oil Drain Plug** – Remove this drain plug when draining of the oil from the engine crankcase is required. Fill with recommended type oil as listed in Table 6.
19. **Air Cleaner** – Prevents dirt and other debris from entering the fuel system. Remove wing-nut on top of air filter canister to gain access to filter element. **NEVER** run the engine without an air cleaner.
20. **Fuel Tank Cap** – Remove this cap to add unleaded gasoline to the fuel tank. **Replenish** with **clean unleaded** gasoline. Make sure cap is tightened securely. **DO NOT** over fill.
21. **Fuel Gauge** – This gauge is located on top of the fuel tank. Read this gauge to determine when fuel is **low**.
22. **Fuel Tank** – Fuel tank capacity is 5 gallons (19 liters).

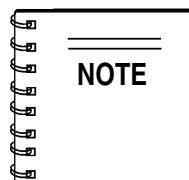

This **HONDA** engine is equipped with a low oil shutdown capability. A built in sensor will automatically turn off the engine should the oil level fall below a safe operating condition. Make sure the generators is placed on level ground. Placing the generators on level ground will ensure that the low oil sensor will function properly.

# GA-6H/GA-6HA — GENERATOR REFUELING

## DANGER

Adding fuel to the tank should be done only when the engine is stopped and has had an opportunity to cool down. In the event of a fuel spill, **DO NOT** attempt to start the engine until the fuel residue has been completely wiped up, and the area surrounding the engine is dry. If generator is placed in a truck bed with a plastic liner, **REMOVE** generator from truck bed and place on ground (Figure 4) to refuel. This possibility exist of **fire** or **explosion** due to static electricity.

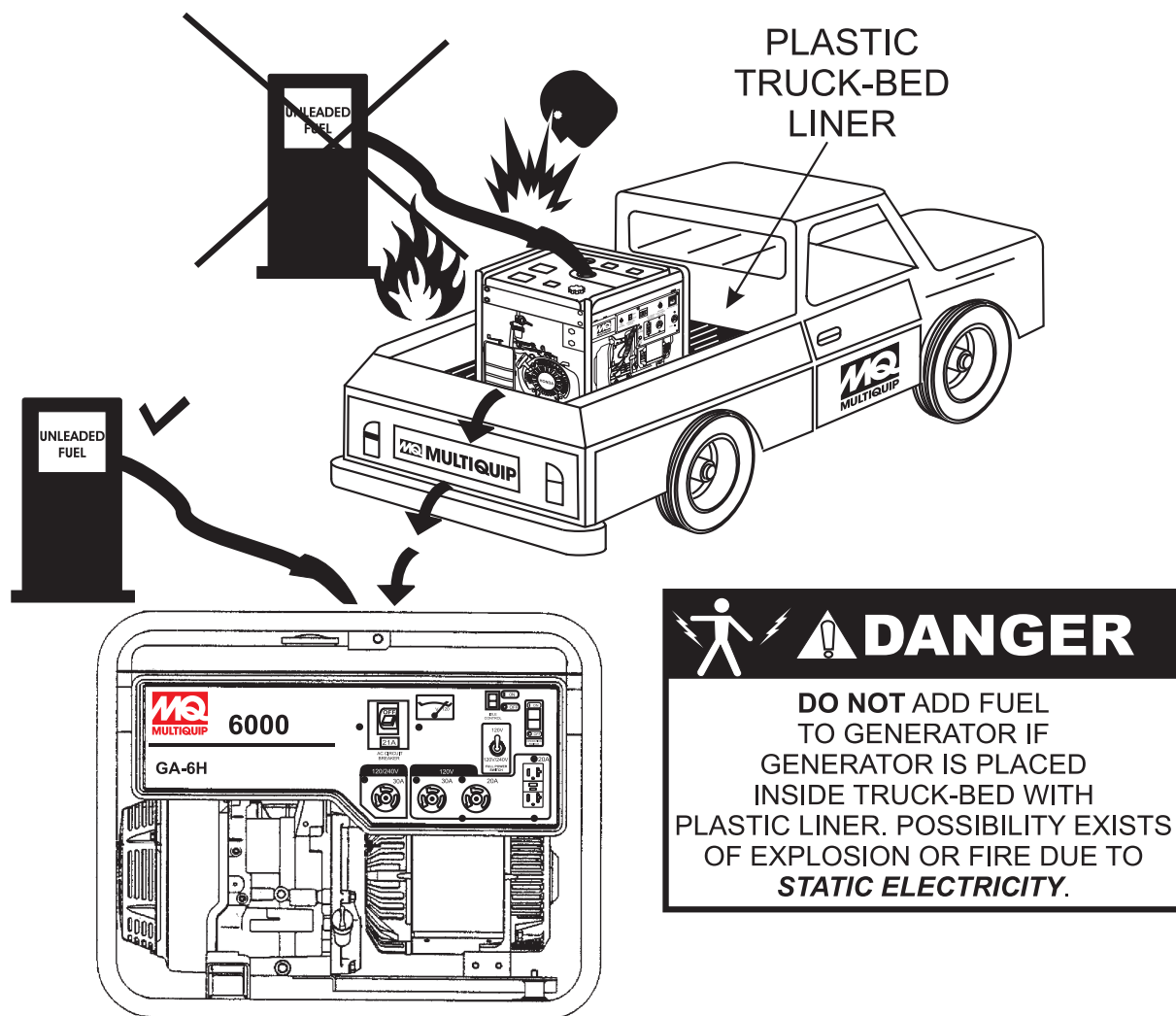



Figure 4. Generators Refueling

## Outdoor Installation

Install the generator/welder in a area that is free of **debris**, **bystanders**, and **overhead obstructions**. Make sure the generators is on secure level ground so that it cannot slide or shift around. Also install the generators in a manner so that the exhaust will not be discharged in the direction of nearby homes.



The installation site must be relatively free from moisture and dust. All electrical equipment should be protected from excessive moisture. Failure to do will result in deterioration of the insulation and will result in short circuits and grounding.

Foreign materials such as dust, sand, lint and abrasive materials have a tendency to cause excessive wear to engine and alternator parts.

|  |  |
|--|--|
|  <b>CAUTION</b>   |  |
| Pay close attention to ventilation when operating the generators inside tunnels and caves. The engine exhaust contains noxious elements. |  |

## Mounting

The generators should always be mounted on a flat level surface to isolate vibration of the generators when it is running. **DO NOT** place the generators on slopes, the possibility exists that the generators could slide.

|  |   |
|--|---|
|  <b>CAUTION</b>   |  |
| An electric shock is apt to happen when vibrators are used. Pay close attention to handling when operating vibrators and always use rubber boots and gloves to insulate the body from a short circuit. |   |

## Indoor Installation

Exhaust gases from gasoline engines are extremely poisonous. Whenever an engine is installed indoors the exhaust fumes must be vented to the outside. The engine should be installed at least two feet from any outside wall. Using an exhaust pipe which is too long or too small can cause excessive back pressure which will cause the engine to heat excessively and possibly burn the valves.

Eliminate the danger of deadly carbon monoxide gas. Remember that exhaust fumes from any gasoline engine are very poisonous if discharged in a closed room, but harmless if allowed to mix with the outside air. If the generators is installed indoors, you must make provisions for venting the engine exhaust to the outside of the building.

## Generators Grounding

To guard against electrical shock and possible damage to the equipment, it is important to provide a good **EARTH** ground. Always use the ground terminal on the generators to ground the generator. Ground the generators from its ground connector so that the resistance to ground is 500 ohms or less.

Article 250 (Grounding) of the National Electrical Code (NEC) provides guide lines for proper grounding and specifies that the cable ground shall be connected to the grounding system of the building as close to the point of cable entry as practical.

NEC articles 250-64(b) and 250-66 set the following grounding requirements:

1. Use one of the following wire types to connect the generators to earth ground.
  - a. Copper - 10 AWG (5.3 mm<sup>2</sup>) or larger.
  - b. Aluminum - 8 AWG (8.4 mm<sup>2</sup>) or larger.
2. When grounding the generators (Figure 3) connect the ground cable between the lock washer and the nut on the generators and tighten the nut fully. Connect the other end of the ground cable to earth ground.
3. NEC article 250-52(c) specifies that the earth ground rod should be buried a minimum of 8 ft. into the ground.

## Connecting the Ground

The nut and ground terminal on the generators should always be used to connect the generators to a suitable ground. The ground cable should be #8 size wire minimum.

At the generator, connect the terminal of the ground cable between the lock washer and the nut (Figure 5) and tighten the nut fully. Connect the other end of the ground cable to a suitable earth ground (ground rod).

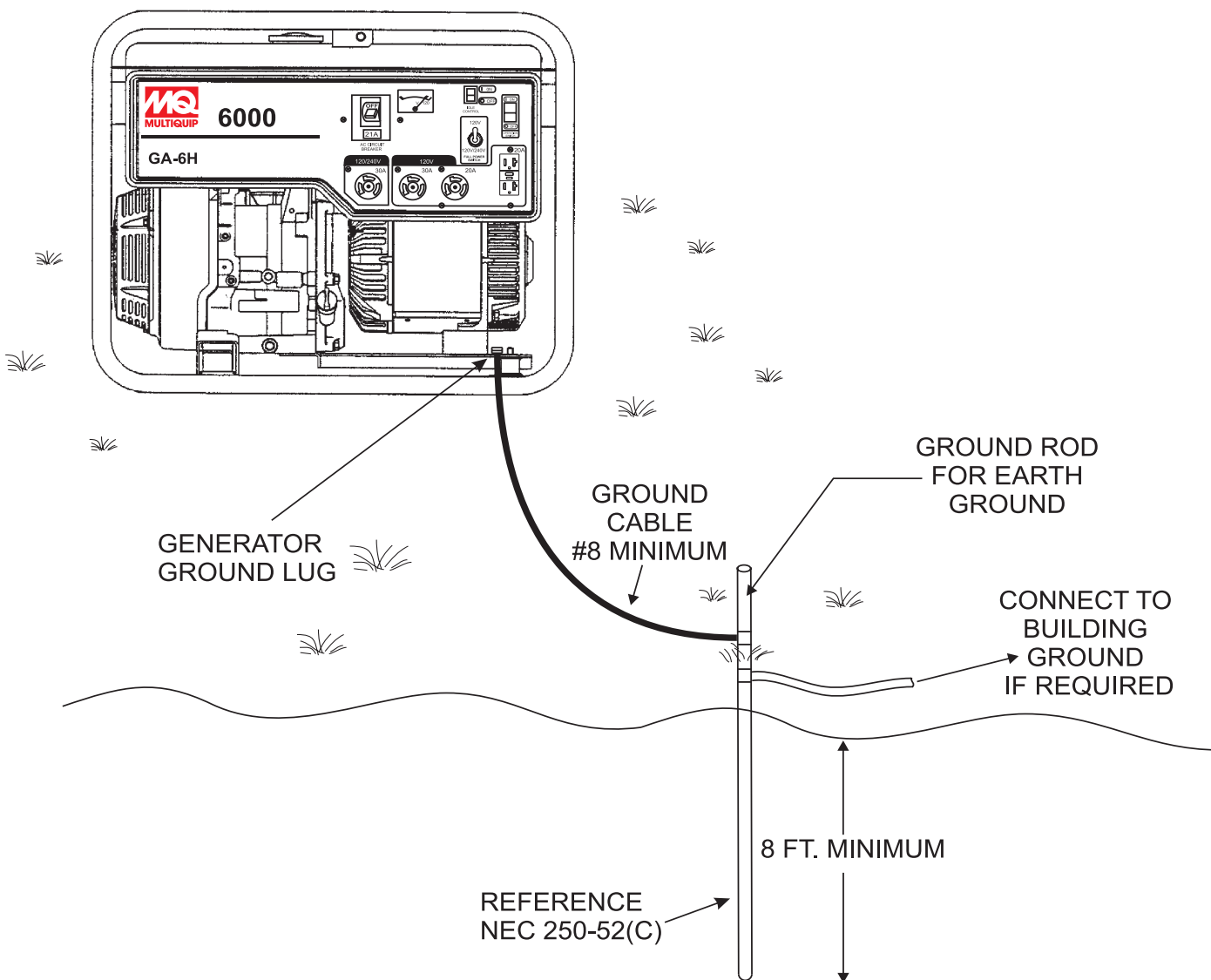

Figure 5. Generators Grounding

## General Inspection Prior to Operation

### Ground Power Tools

When using power tools or electrical equipment requiring AC power from the generator, make sure connecting (power tool) cable (Figure 6) has a ground as shown in Figure.

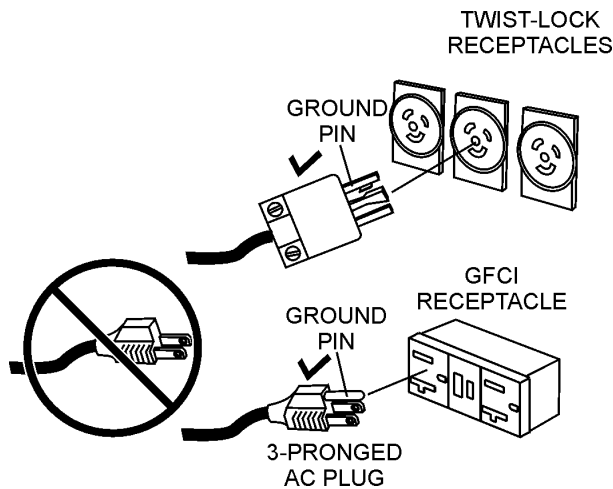
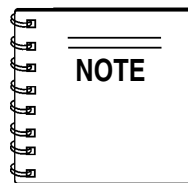

Figure 6. Ground Cables/Plugs

### Extension Cable

When electric power is to be provided to various tools or loads at some distance from the generator, extension cords are normally used. Cables should be sized to allow for distance in length and amperage so that the voltage drop between the generators and point of use (load) is held to a minimum. Use the cable selection chart (Table 4) as a guide for selecting proper cable size.



**Never!** use power tools or equipment that do not have a ground capability, the possibility exists of **electrocution, electrical shock or burn**, which can cause **severe bodily harm** or even **DEATH!**

### Main Circuit Breaker

To protect the generators from an overload always place the main circuit breaker in the "OFF" position prior to starting the engine.

Table 4. Cable Selection (60 Hz, Single Phase Operation)

| Current In Amperes | Load In Watts |           | Maximum Allowable Cable Length |          |          |          |
|--------------------|---------------|-----------|--------------------------------|----------|----------|----------|
|                    | 120 Volts     | 240 Volts | #10 Wire                       | #12 Wire | #14 Wire | #16 Wire |
| 2.5                | 300           | 600       | 1000 ft.                       | 600 ft.  | 375 ft.  | 250 ft.  |
| 5                  | 600           | 1200      | 500 ft.                        | 300 ft.  | 200 ft.  | 125 ft.  |
| 7.5                | 900           | 1800      | 350 ft.                        | 200 ft.  | 125 ft.  | 100 ft.  |
| 10                 | 1200          | 2400      | 250 ft.                        | 150 ft.  | 100 ft.  |          |
| 15                 | 1800          | 3600      | 150 ft.                        | 100 ft.  | 65 ft.   |          |
| 20                 | 2400          | 4800      | 125 ft.                        | 75 ft.   | 50 ft.   |          |

**CAUTION:** Equipment damage can result from low voltage.

# GA-6H/GA-6HA — PRE-INSPECTION (ENGINE)

## CAUTION

**NEVER** operate the generators in a confined area or enclosed area structure that does not provide ample *free flow of air*.



**ALWAYS** wear approved eye and hearing protection before operating the generator.

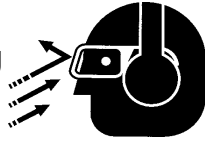

### Before Starting

1. Read safety instructions at the beginning of manual.
2. Clean the generator, removing dirt and dust, particularly the engine cooling air inlet, carburetor and air cleaner.
3. Check the air filter for dirt and dust. If air filter is dirty, replace air filter with a new one as required.
4. Check carburetor for external dirt and dust. Clean with dry compressed air.
5. Check fastening nuts and bolts for tightness.



### Engine Oil Check

1. To check the engine oil level, place the generators on secure level ground with the engine stopped.
2. Remove the filler dipstick from the engine oil filler hole (Figure 7) and wipe clean.

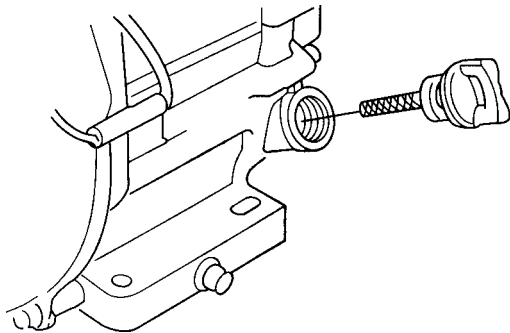

Figure 7. Engine Oil Dipstick (Removal)

3. Insert and remove the dipstick without screwing it into the filler neck. Check the oil level shown on the dipstick.
4. If the oil level is low (Figure 8), fill to the edge of the oil filler hole with the recommended oil type (Table 5). Maximum oil capacity is 1.16 quarts (1.1 liters)

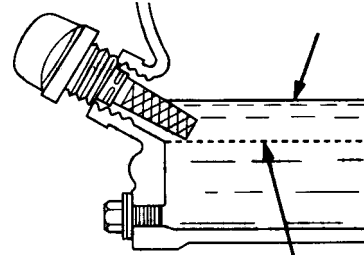

Figure 8. Engine Oil Dipstick (Oil Level)

Table 5. Oil Type

| Season      | Temperature    | Oil Type      |
|-------------|----------------|---------------|
| Summer      | 25°C or Higher | SAE 10W-30    |
| Spring/Fall | 25°C~10°C      | SAE 10W-30/20 |
| Winter      | 0°C or Lower   | SAE 10W-10    |

## DANGER EXPLOSIVE FUEL

Motor fuels are highly flammable and can be dangerous if mishandled. **DO NOT** smoke while refueling. **DO NOT** attempt to refuel the generators if the engine is *hot!*, *running or in the dark*.



### Fuel Check

1. Close the fuel cock before filling the fuel tank.
2. Remove the fuel cap located on top of fuel tank.
3. Read the fuel gauge located on top of the fuel tank (Figure 9) to determine if the fuel level is low. If fuel is low, replenish with *clean unleaded fuel*.

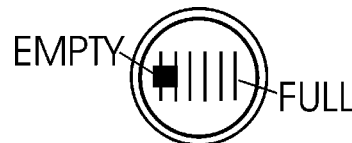

Figure 9. Fuel Gauge

4. When refueling, be sure to use a strainer for filtration. **DO NOT** top-off fuel. **DO NOT** fill the tank beyond capacity. Wipe up any spilled fuel *immediately!*



# GA-6H/GA-6HA — INITIAL START-UP (ENGINE)

## ⚠ CAUTION

**DO NOT** attempt to operate this generators until the Safety, General Information and Inspection sections of this manual have been **read and thoroughly understood**.



This section is intended to assist the operator with the **initial start-up** of the portable generator. It is extremely important that this section be read carefully before attempting to use the generators in the field.

### Before Starting the Engine

1. Be sure to **disconnect all electrical loads** from the generators prior to starting the engine.
2. **NEVER** start the engine with the main circuit breaker in the "ON" position. Always place this circuit breakers (Figure 10) in the **OFF** position before starting.

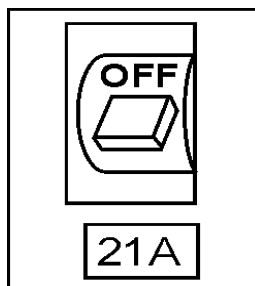

Figure 10. Main Circuit Breaker (OFF Position)

### Starting the Engine

1. Place the engine **fuel valve lever** (Figure 11) to the "ON" position."

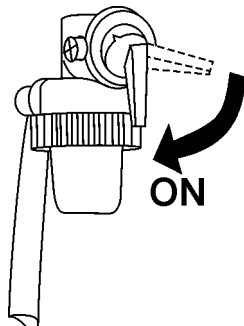

Figure 11. Engine Fuel Valve Lever (ON Position)

2. Place the **choke lever** (Figure 12) in the "CLOSED" position if starting a **cold** engine.

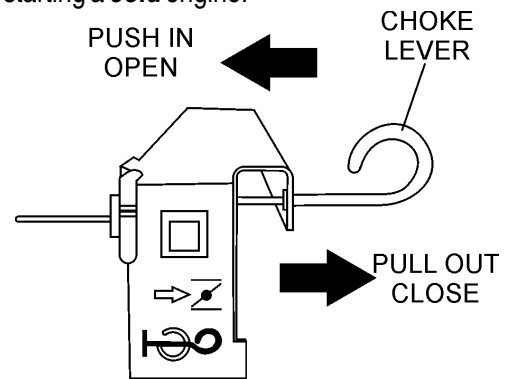

Figure 12. Choke Lever

3. Place the **choke lever** (Figure 12) in the "OPEN" position if starting a **warm engine** or the **temperature is warm**.
4. Place the **generator's operation switch** (Figure 13) in the "ON" position.

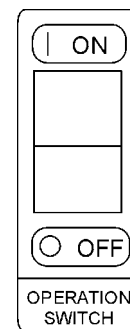

Figure 13. Generator On/Off Switch (ON)

5. Grasp the starter grip (Figure 14) and slowly pull it out. The resistance becomes the hardest at a certain position, corresponding to the compression point. Pull the starter grip briskly and smoothly for starting.

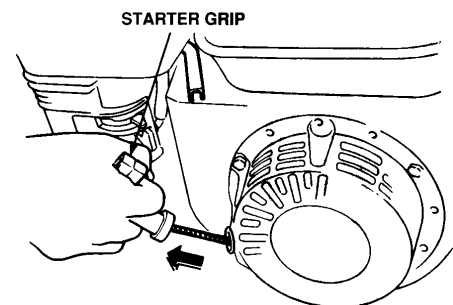

Figure 14. Starter Grip

## ⚠ CAUTION

**DO NOT** pull the starter rope all the way to the end.  
**DO NOT** release the starter rope after pulling. Allow it to rewind as soon as possible.

# GA-6H/GA-6HA — INITIAL START-UP/GENERATOR OPERATION

- If the engine has started, slowly return the choke lever (Figure 12 ) to the **"OPEN"** position. If the engine has not started repeat steps 1 through 5.
- Before the generators is placed into operation, run the engine for 3-5 minutes. Check for abnormal smells, fuel leaks, and noises that would associate with lose components.
- Place** the *idle control switch* (Figure 15) in the **"OFF"** (down) position. This will allow the engine speed to run at speed about 3600 RPM's

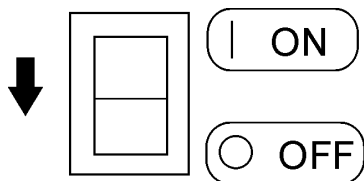
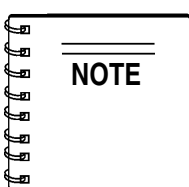

Figure 15. Idle Control Switch (Off)



Placing the *idle control switch* in the **OFF** position (Figure 15) allows the engine to operate at a maximum speed of about 3600 RPM's. When the idle control switch is placed in the up position (**ON**) (Figure 16), the generators will run at idle speed (2200 RPM's) until a load is applied, at that time the engine speed will increase to 3600 RPM's as long as the load is being applied. When the load is not in use, the engine speed will drop back to the idle mode after about 3 seconds.

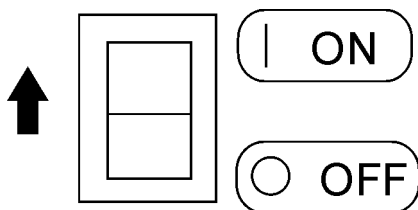

Figure 16. Idle Control Switch (On)

## 60 Hz Operation

- Place main circuit breaker (Figure 17) in the **ON** position.

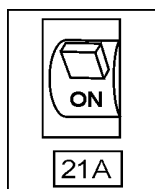

Figure 17. Main Circuit Breaker (ON)

- Place the full power switch (Figure 18) in the 120V position (up).

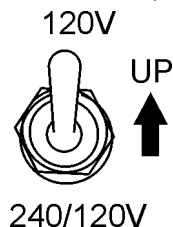
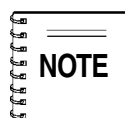

Figure 18. Full Power Switch 120 V Position (Up)



When the *full power switch* is in the 120V position, the 240V twist-lock receptacle cannot be used.

- Read the *voltmeter* on the front panel of the generators (Figure 19) and verify that 120 VAC is present at the 120V twist-lock and GFCI duplex receptacles. For additional verification of voltage, an external voltmeter can be used to measure the output voltage as shown in Figure 19.

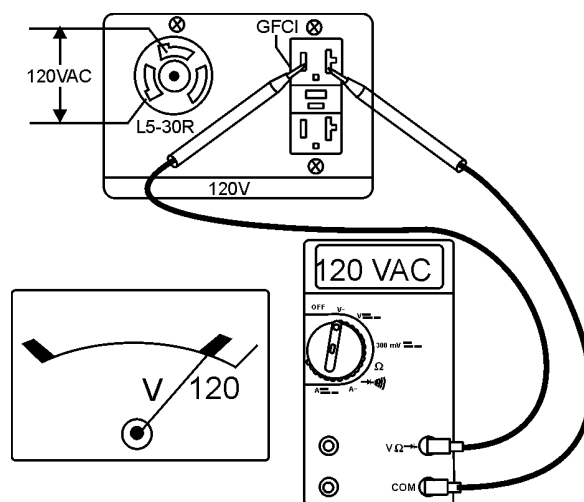

Figure 19. 120 V and GFCI Receptacles

- Place the full power switch (Figure 20) in the 240V position (down).

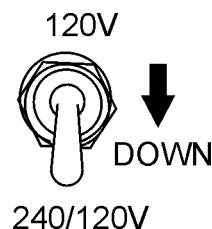

Figure 20. Full Power Switch 240/120 V Position (Down)

# GA-6H/GA-6HA — GENERATOR OPERATION/SHUTDOWN

- Read the **voltmeter** on the front panel of the generators (Figure 21) and verify that 240 VAC is present at the 240V twist-lock receptacle. Using an external voltmeter verify that 120V is present at the 120V twist-lock and GFCI duplex receptacles.

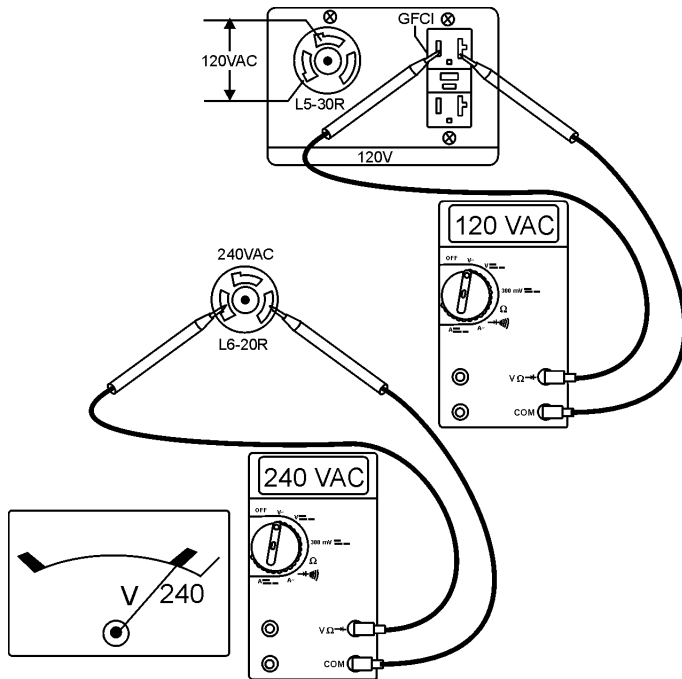
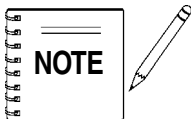
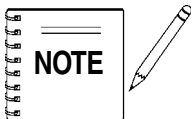

Figure 21. 60 Hz Output Receptacles



When the full power switch is in the 240 volt (down) position, you can take up to **half of the rated power** of the generating set at 120 volts from the GFCI duplex receptacle and up to half of the rated power of the set at 120 volts from the 120V twist-lock receptacle; or full rated power of the genset at 240 volts from the 240V twist-lock receptacle.



When using a combination of dual receptacles, total load should not exceed the rated capacity of the generator.

## Connecting the Load

- If small wattage power tools are required, connect them to the 60 Hz output receptacles at this time.

## Stopping the Engine

- Place the main circuit breaker (Figure 22) in the **OFF** position.

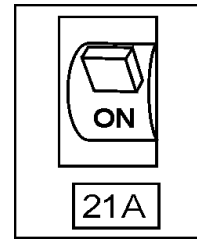

Figure 22. Main Circuit Breakers (Off)

- Place the **idle control switch** (Figure 23) in the **OFF** position.

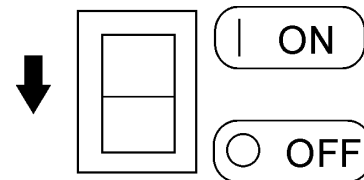

Figure 23. Idle Control Switch (Off)

- Let the engine run at idle with no load for 2-3 minutes.
- To shut-down the engine, place the generator's operation switch (Figure 24) in the **OFF** position.

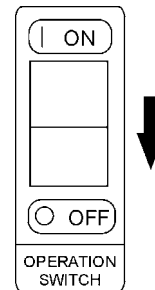

Figure 24. Generators On/Off Switch (Off)

- Place the engine **fuel valve lever** (Figure 25) to the "OFF" position."

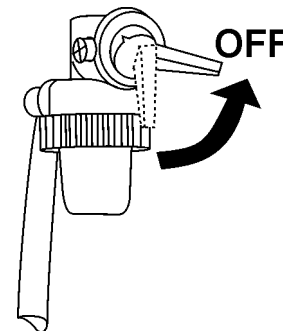

Figure 25. Engine Fuel Valve Lever (OFF Position)

- Remove all **loads** from the generator.

## GA-6H/GA-6HA — PREPARATION FOR LONG TERM STORAGE

### Generators Storage

For storage of the generating set for over 30 days, the following is required:

- Drain the fuel tank completely, or add STA-BIL to the fuel.
- Run the engine until the gasoline in the carburetor is completely consumed.
- Completely drain the oil from the crankcase and refill with fresh oil.
- Remove the spark plug, pour 2 or 3 cc of SAE 30 oil into the cylinder and crank slowly to distribute the oil.
- Slowly rotate the engine a few times with the starter Rope and install a new plug.
- Pull out the starter rope slowly and stop at the compression point.
- Clean all external parts of the generating set with a cloth.
- Cover the generating set and store in a clean, dry place.



# GA-6H/GA-6HA — MAINTENANCE (ENGINE)

Use Table 6 as a general maintenance guideline when servicing your engine. For more detail engine maintenance information, refer to the engine owner's manual supplied with your engine.

**Table 6. Engine Maintenance Schedule**

| DESCRIPTION (3)  | OPERATION               | BEFORE                                   | FIRST MONTH OR 10 HRS. | EVERY 3 MONTHS OR 25 HRS. | EVERY 6 MONTHS OR 50 HRS. | EVERY YEAR OR 100 HRS. | EVERY 2 YEARS OR 200 HRS. |
|------------------|-------------------------|--|------------------------|---------------------------|---------------------------|------------------------|---------------------------|
| Engine Oil       | CHECK                   | X  |                        |                           |                           |                        |                           |
|                  | CHANGE                  |  | X                      |                           |                           |                        |                           |
| Air Cleaner      | CHECK                   | X  |                        |                           |                           |                        |                           |
|                  | CHANGE                  |  |                        | X (1)                     |                           |                        |                           |
| All Nuts & Bolts | Re-tighten If Necessary | X  |                        |                           |                           |                        |                           |
| Spark Plug       | CHECK-CLEAN             |  |                        |                           | X                         |                        |                           |
|                  | REPLACE                 |  |                        |                           |                           |                        | X                         |
| Cooling Fins     | CHECK                   |  |                        |                           | X                         |                        |                           |
| Spark Arrester   | CLEAN                   |  |                        |                           |                           | X                      |                           |
| Fuel Tank        | CLEAN                   |  |                        |                           |                           | X                      |                           |
| Fuel Filter      | CHECK                   |  |                        |                           |                           | X                      |                           |
| Idle Speed       | CHECK-ADJUST            |  |                        |                           |                           | X (2)                  |                           |
| Valve Clearance  | CHECK-ADJUST            |  |                        |                           |                           |                        | X (2)                     |
| Fuel lines       | CHECK                   | Every 2 years (replace if necessary) (2) |                        |                           |                           |                        |                           |

(1) Service more frequently when used in **DUSTY** areas.

(2) These items should be serviced by your service dealer, unless you have the proper tools and are mechanically proficient. Refer to the HONDA Shop Manual for service procedures.

(3) For commercial use, log hours of operation to determine proper maintenance intervals.

## Maintenance

Perform the scheduled maintenance procedures as defined by Table 6 and below:

### DAILY

- Thoroughly remove dirt and oil from the engine and control area. Clean or replace the air cleaner elements as necessary. Check and retighten all fasteners as necessary. Check the gearbox for oil leaks. Repair or replace as needed.

### WEEKLY

- Remove the fuel filter cap and clean the inside of the fuel tank.
- Remove or clean the filter at the bottom of the tank.
- Remove and clean the spark plug (Figure 26), then adjust the spark gap to 0.024 ~0.028 inch (0.6~0.7 mm). This unit has electronic ignition, which requires no adjustments.

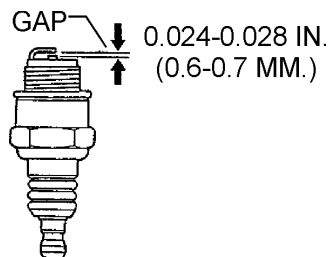

Figure 26. Spark Plug Gap

### ENGINE OIL

- Drain the engine oil when the oil is **warm** as shown in Figure 27.
- Remove the oil drain bolt and sealing washer and allow the oil to drain into a suitable container.
- Replace engine oil with recommended type oil as listed in Table 5. For engine oil capacity, see Table 2 (engine specifications). **DO NOT** overfill.
- Install drain bolt with sealing washer and tighten securely.

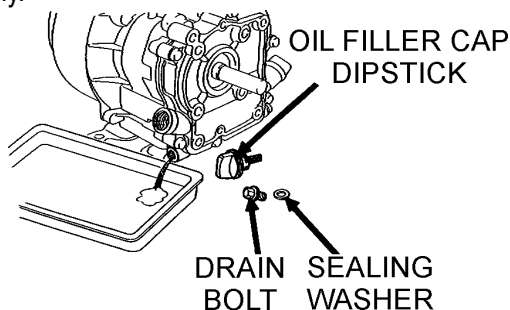

Figure 27. Engine Oil (Draining)

## **!** DANGER

**DO NOT** use gasoline as a cleaning solvent, because that would create a risk of fire or explosion.



### ENGINE AIR CLEANER

- Remove the air cleaner cover and foam filter element as shown in Figure 28.
- Clean foam element in warm, soapy water or nonflammable solvent. Rinse and dry thoroughly. Dip the element in clean engine oil and completely squeeze out the excess oil from the element before installing.

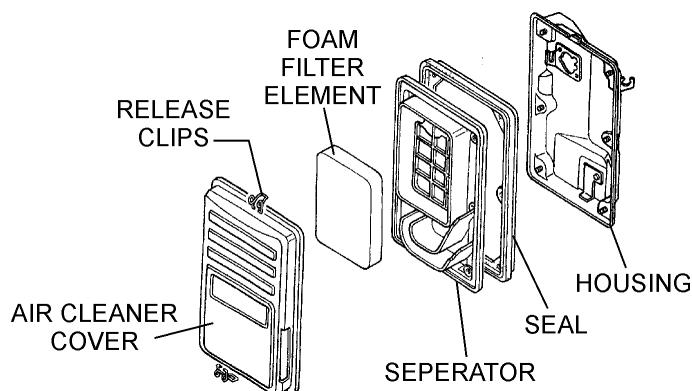
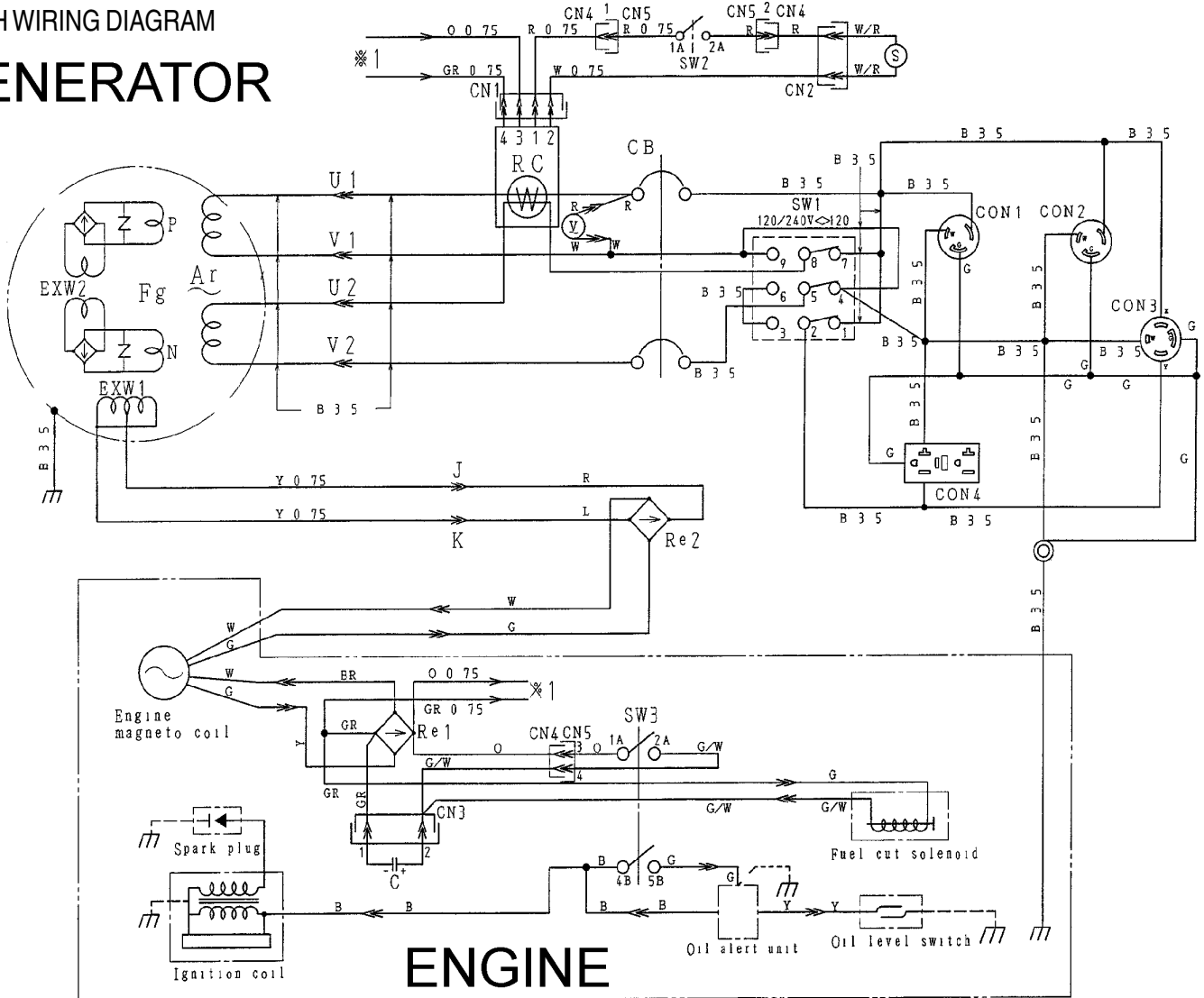

Figure 28. Engine Air Cleaner

# GA-6H — WIRING DIAGRAM (GENERATOR)

GA-6H WIRING DIAGRAM

## GENERATOR



## ENGINE

| COLOR CODE |            |    |             |
|------------|------------|----|-------------|
| WIRE COLOR | WIRE COLOR |    |             |
| B          | BLACK      | R  | RED         |
| L          | BLUE       | W  | WHITE       |
| BR         | BROWN      | Y  | YELLOW      |
| G          | GREEN      | LB | LIGHT BLUE  |
| GR         | GRAY       | LG | LIGHT GREEN |
| V          | VIOLET     | O  | ORANGE      |
| P          | PINK       |    |             |

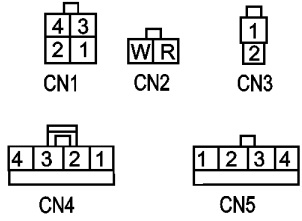

CONNECTOR ARRANGEMENT  
(VIEW FROM INSERTING WIRE SIDE)

| SYMBOL  | DESIGNATION                            |
|---------|--|
| Ar      | ARMATURE WINDING                       |
| Fg-P, N | ROTOR ASSEMBLY                         |
| Ex W1   | EXCITATION WINDING                     |
| Ex W2   | EXCITATION WINDING                     |
| V       | AC VOLTMETER 120/240V                  |
| RE 1, 2 | RECTIFIER                              |
| CB      | CIRCUIT BREAKER 25A @ 240, 37.5A @ 120 |
| CON 1   | RECEPTACLE L5-20R 20A, 125V            |
| CON 2   | RECEPTACLE L5-30R 30A 125V             |
| CON 3   | RECEPTACLE L14-30R 30A, 125/250V       |
| CON 4   | RECEPTACLE 520R GFCI 20A, 125V         |
| SW1     | FULL POWER SWITCH                      |
| SW2     | IDLE CONTROL SWITCH                    |
| SW3     | OPERATION SWITCH                       |
| RC      | IDLE CONTROL DEVICE                    |
| S       | IDLE CONTROL SOLENOID                  |
| C       | CAPACITOR                              |

Figure 29. Generators Wiring Diagram (GA-6H)



# GA-6HA — WIRING DIAGRAM (GENERATOR)

GA-6HA WIRING DIAGRAM

## GENERATOR

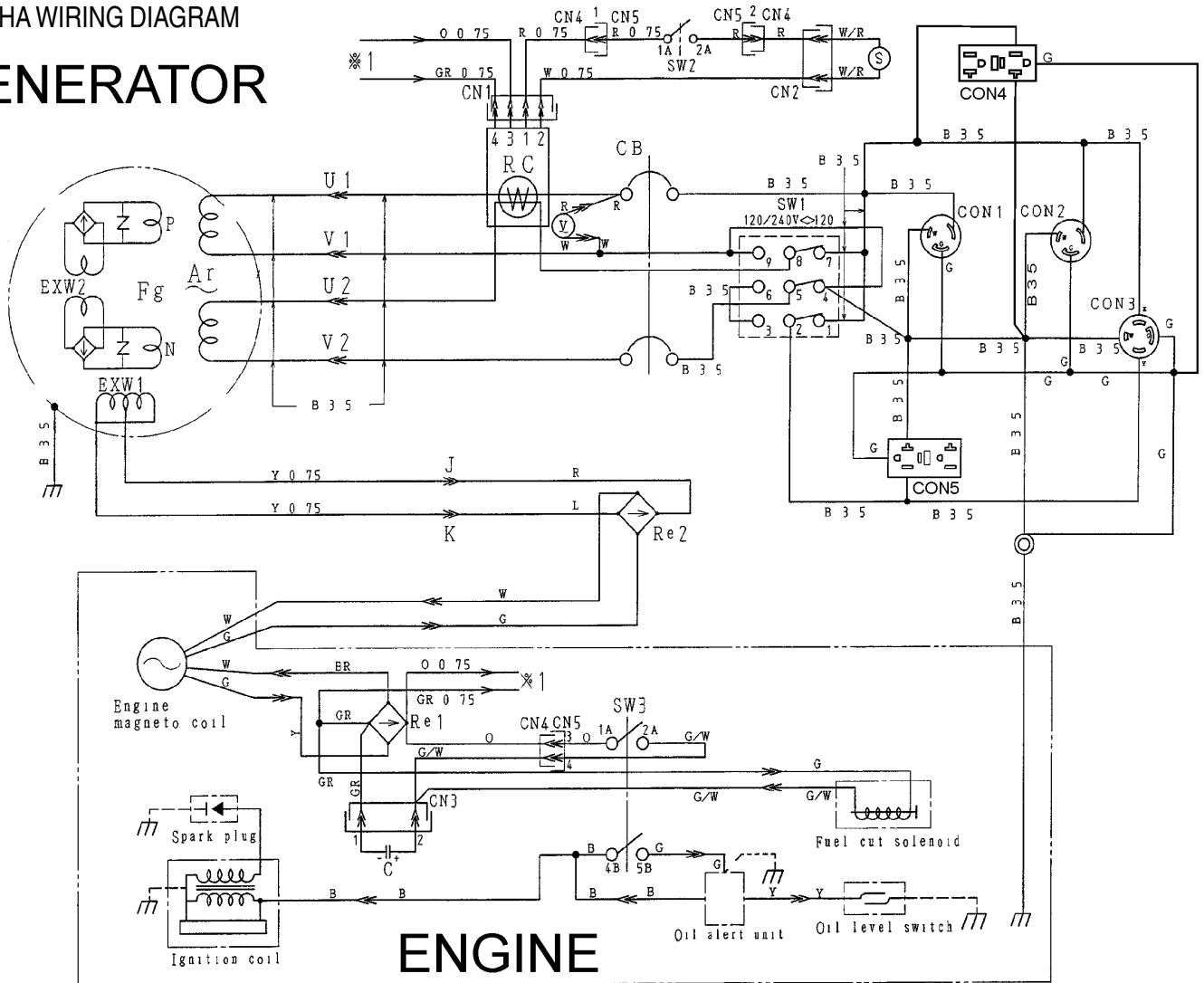

## ENGINE

| COLOR CODE |        |            |             |
|------------|--------|------------|-------------|
| WIRE COLOR |        | WIRE COLOR |             |
| B          | BLACK  | R          | RED         |
| L          | BLUE   | W          | WHITE       |
| BR         | BROWN  | Y          | YELLOW      |
| G          | GREEN  | LB         | LIGHT BLUE  |
| GR         | GRAY   | LG         | LIGHT GREEN |
| V          | VIOLET | O          | ORANGE      |
| P          | PINK   |            |             |

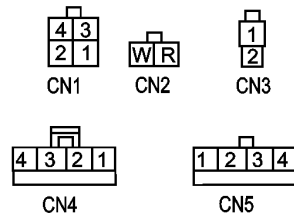

CONNECTOR ARRANGEMENT  
(VIEW FROM INSERTING WIRE SIDE)

| SYMBOL  | DESIGNATION                          |
|---------|--------------------------------------|
| Ar      | ARMATURE WINDING                     |
| Fg-P, N | ROTOR ASSEMBLY                       |
| Ex W1   | EXCITATION WINDING                   |
| Ex W2   | EXCITATION WINDING                   |
| V       | AC VOLTMETER 120/240V                |
| RE 1, 2 | RECTIFIER                            |
| CB      | CIRCUIT BREAKER 25A @ 240, 50A @ 120 |
| CON 1   | RECEPTACLE L5-20R 20A, 125V          |
| CON 2   | RECEPTACLE L5-30R 30A 125V           |
| CON 3   | RECEPTACLE L14-30R 30A, 125/250V     |
| CON 4,5 | RECEPTACLE 520R GFCI 20A, 125V       |
| SW1     | FULL POWER SWITCH                    |
| SW2     | IDLE CONTROL SWITCH                  |
| SW3     | OPERATION SWITCH                     |
| RC      | IDLE CONTROL DEVICE                  |
| S       | IDLE CONTROL SOLENOID                |
| C       | CAPACITOR                            |

Figure 30. Generators Wiring Diagram (GA-6HA)

# GA-6H/GA-6HA — TROUBLESHOOTING (ENGINE)

Practically all breakdowns can be prevented by proper handling and maintenance inspections, but in the event of a breakdown, please take a remedial action following the diagnosis based on the Engine Troubleshooting (Table 7) and

Generators Troubleshooting (Table 8) information shown below and on the proceeding page. If the problem cannot be remedied, please leave the unit just as it is and consult our company's business office or service plant.

**TABLE 7. ENGINE TROUBLESHOOTING**

| SYMPTOM                                    | POSSIBLE PROBLEM  | SOLUTION  |
|--|---|---|
| Poor starting                              | Inspect carburetor to see if fuel is reaching it?                   | Check fuel line   |
|  | No Fuel?  | Add Fuel  |
|  | Water in fuel tank?   | Flush or replace fuel tank.   |
|  | Fuel filter clogged?  | Replace fuel filter   |
|  | Stuck carburetor?   | Check float mechanism.  |
|  | Spark plug is red?  | Spark plug is fouled. Check transistor ignition unit.   |
|  | Spark plug is blue-white?   | Insufficient compression, injected air leaking. Carburetor jets are clogged (overflow).                                       |
|  | No spark present at tip of spark plug?                              | Transistor ignition unit broken, high voltage cord cracked or broken. Start/Stop switch broken. Replace spark plug if fouled. |
|  | No oil?   | Add oil as required.  |
|  | Oil pressure alarm lamp blinks upon starting?                       | Check Automatic shutdown circuit "oil sensor".  |
| Insufficient power output "no compression" | Engine will not turn over?  | Replace cylinder and piston and if necessary axel joint.  |
|  | Cylinder head connecting bolts loose?                               | Tighten cylinder head connecting bolts.   |
|  | Cylinder head gasket damaged?                                       | Replace cylinder head gasket.   |
|  | Malfunction of valve seat?  | Re-seat valves.   |
|  | Spark plug is loose?  | Replace spark plug.   |
|  | Worn piston rings?  | Replace piston rings.   |
| Insufficient power output "compression"    | Malfunction in air-cleaner system, air filter clogged?              | Clean or replace air filter.  |
|  | Air leaking in from interface between carburetor and cylinder head? | Tighten bolts between carburetor and cylinder head. Replace cylinder head gasket.   |
|  | Malfunction in fuel system?   | Clean or replace fuel filter.<br>Clean or replace carburetor.<br>Check carburetor float.                                      |

# GA-6H/GA-6HA — TROUBLESHOOTING (ENGINE)

**TABLE 7. ENGINE TROUBLESHOOTING (CONTINUED)**

| SYMPTOM  | POSSIBLE PROBLEM                                      | SOLUTION  |
|--|---|---|
| Insufficient power output<br>"compression" and overheats | Malfunction in cooling fan?                           | Check or replace cooling fan.                                   |
|  | Air in-take filter clogged?                           | Clean or replace air in-take filter.                            |
| Burns to much fuel                                       | Over accumulation of exhaust products?                | Clean and check valves.<br>Check muffler, replace if necessary. |
|  | Wrong spark plug?                                     | Replace spark plug with manufactures suggested type spark plug. |
| Exhaust color is continously<br>"WHITE"                  | Lubricating oil is wrong viscosity?                   | Replace lubricating oil with correct viscosity.                 |
|  | Worn rings?   | Replace rings   |
| Exhaust color is continously<br>"BLACK"                  | Air cleanner clogged?                                 | Clean or replace air cleaner.                                   |
|  | Choke valve has not been set to the correct position? | Adjust choke valve to the correct position.                     |
|  | Carburetor defective, seal on carburetor broken?      | Replace carburetor or seal.                                     |
|  | Poor carburetor adjustment<br>"engine runs too rich?" | Adjust carburetor.  |

# GA-6H/GA-6HA — TROUBLESHOOTING (GENERATOR)

**TABLE 8. GENERATOR TROUBLESHOOTING**

| SYMPTOM   | POSSIBLE PROBLEM                         | SOLUTION   |
|---|--|--|
| Low voltage   | Engine speed too low?                    | Raise engine speed to rated RPM.   |
| Low voltage. Engine speed normal 3650 RPM (unloaded), 2500 RPM (idle)             | AC voltmeter not working?                | Replace Ac voltmeter.  |
|   | Control box internal wiring malfunction? | Check control box wiring.  |
|   | Defective ignition coil?                 | Check red and green ignition wires. Replace ignition wires if necessary. |
|   | Rotor winding malfunction?               | Check or replace rotor.  |
|   | Stator winding malfunction?              | Check or replace stator.   |
|   | Leakage breaker malfunction?             | Check or replace CB1.  |
|   | Full power switch malfunction?           | Check full power switch and full power switch circuit.                   |
| Voltage output too high.  | Engine speed too high?                   | Lower engine speed to rated RPM.   |
| Voltage output too high. Engine speed normal 3650 RPM (unloaded), 2500 RPM (idle) | Control box internal wiring malfunction  | Check control box wiring.  |
| Circuit breaker will not turn on "NO LOAD"  | Defective circuit breaker?               | Replace circuit breaker.   |
| Circuit breaker will turn on "LOADED" but trips immediately.                      | Overload Condition?                      | Reduce load or replace breaker.  |
|   | Load circuit is shorted?                 | Check load circuit for short.  |
| Does not accelerate from low to high "NO LOAD"                                    | Stuck solenoid?                          | Check solenoid.  |
|   | Bad Idle control switch?                 | Check or replace idle control switch.                                    |
| Does not accelerate from low to high "LOAD ACTIVE"                                | Idle control switch malfunction?         | Check or replace idle control switch.                                    |
|   | Idle control device malfunction?         | Check or replace idle control device.                                    |
|   | Control box internal wiring defective?   | Check control box wiring.  |
| Does not decelerate no "VOLTAGE OUTPUT".  | Defective rotor windings?                | Check or replace rotor.  |
|   | Defective solenoid?                      | Check or replace solenoid.   |
|   | Defective idle control device?           | Check or replace idle control device.                                    |
|   | Defective solenoid?                      | Check or replace idle control device.                                    |
| Does not decelerate but has "VOLTAGE OUTPUT".                                     | Control box wiring malfunction?          | Check control box wiring, replace any defective components.              |
|   | Defective solenoid?                      | Check or replace solenoid.   |
|   | Idle control device malfunction?         | Check or replace idle control device.                                    |



# GA-6H/GA-6HA — EXPLANATION OF CODE IN REMARKS COLUMN

How to read the marks and remarks used in this parts book.

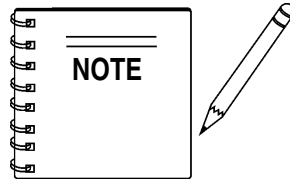

*The contents of this catalog are subject to change without notice.*

## Items Found In the “Remarks” Column

**Serial Numbers**-Where indicated, this indicates a serial number range (inclusive) where a particular part is used.

**Model Number**-Where indicated, this shows that the corresponding part is utilized only with this specific model number or model number variant.

## Items Found In the “Items Number” Column

All parts with same symbol in the number column, \*, #, +, %, or ■, belong to the same assembly or kit.

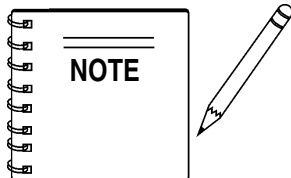

If more than one of the same reference number is listed, the last one listed indicates newest (or latest) part available.

## GA-6H/GA-6HA — SUGGESTED SPARE PARTS

### GA-6H/GA-6HA 1 TO 3 UNITS WITH HONDA GX340K1EDN2 ENGINE

#### *1 to 3 Units*

| <u>Qty.</u> | <u>P/N</u>  | <u>Description</u>  |
|-------------|-------------|---------------------|
| 1           | A9924800014 | CAP FUEL TANK       |
| 1           | A9924800004 | FILTER FUEL         |
| 1           | 3015419604  | SHOCK MOUNT         |
| 4           | 1665419004  | SHOCK MOUNT         |
| 3           | 9807955846  | SPARK PLUG          |
| 1           | 34150ZH7003 | ALERT UNIT, OIL     |
| 2           | 28462ZV7003 | ROPE, RECOIL        |
| 3           | 17211899000 | ELEMENT AIR CLEANER |

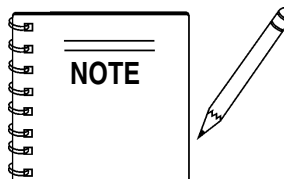

Part numbers on this Suggested Spare Parts List may supercede/replace the P/N shown in the text pages of this book.

# GA-6H/GA-6HA — NAMEPLATE AND DECALS.

## NAME PLATE ASSY.

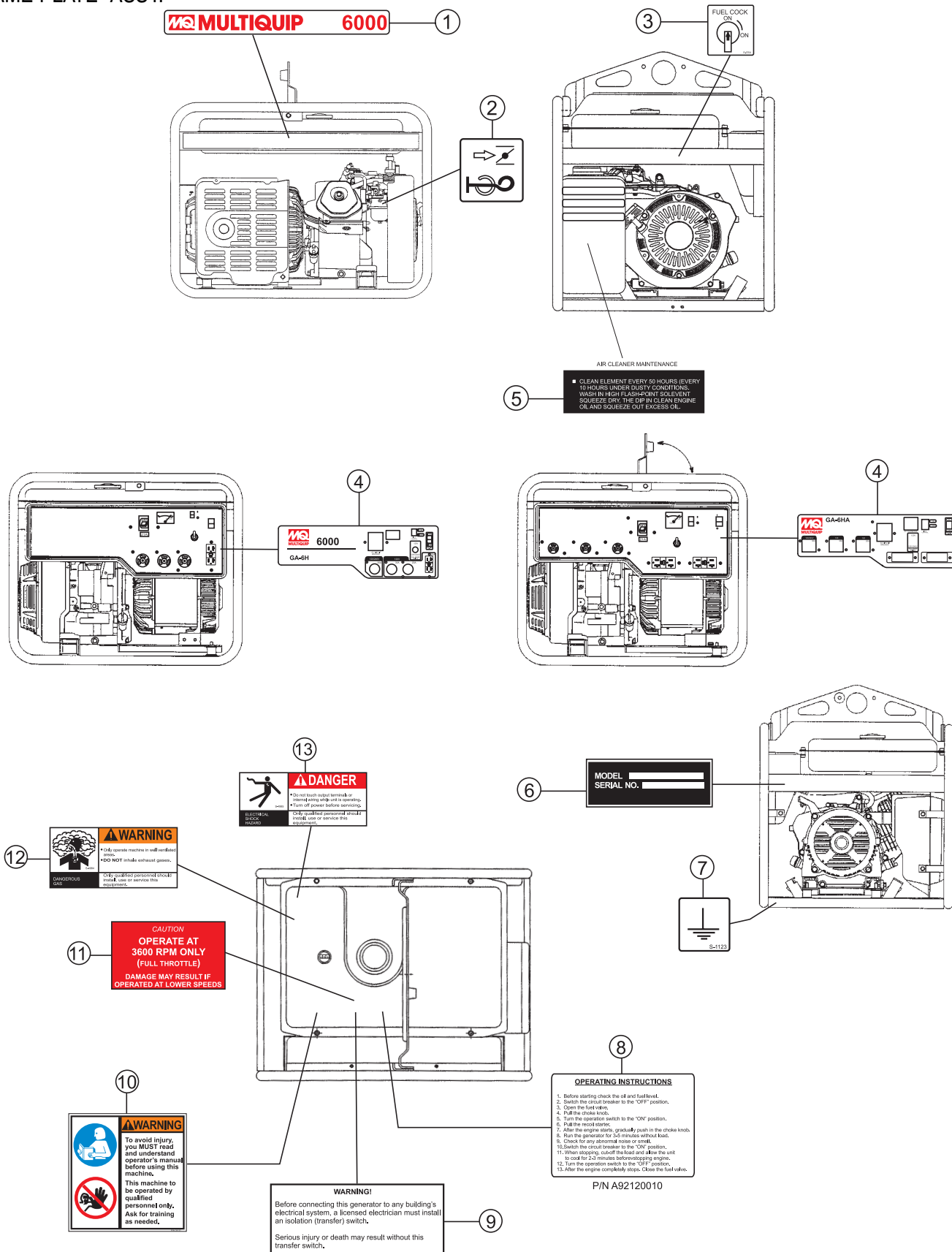



# GA-6H/GA-6HA — NAMEPLATE AND DECALS.

NAME PLATE ASSY.

| <u>NO.</u> | <u>PART NO.</u> | <u>PART NAME</u>                            | <u>QTY.</u> | <u>REMARKS</u>          |
|------------|-----------------|---|-------------|-------------------------|
| 1          | A556100003      | DECAL; MQ MULTIQUIP 6000                    | 1           |                         |
| 2          | 87528898620     | DECAL; CHOKE .....                          | 1           | REPLACES P/N 0600500047 |
| 3          | 1980680004      | DECAL; FUEL COCK .....                      | 1           | S-3704                  |
| 4          | A5511200002     | DECAL; CONTROL PANEL .....                  | 1           | GA-6-H, A51120000       |
| 4          | A5511201202     | DECAL; CONTROL PANEL .....                  | 1           | GA-6-HA, A51120120      |
| 5          | 87533ZC0630     | DECAL; AIR CLEANER .....                    | 1           | REPLACES P/N 0600500045 |
| 6          |                 | NAMEPLATE .....                             | 1           | CONTACT MQ PARTS DEPT.  |
| 7          | 0800628504      | DECAL; GROUND .....                         | 1           | S-1123                  |
| 8          | A9521200104     | DECAL; OPERATING INSTRUCTIONS               | 1           | A92120010               |
| 9          | 0820610404      | DECAL; WARNING .....                        | 1           | S-3627                  |
| 10         | 35137           | DECAL; WARNING                              | 1           |                         |
| 11         | 7900636004      | DECAL; CAUTION OPER. AT 3600 RPM ONLY ..... | 1           | S-4461                  |
| 12         | 8700611804      | DECAL; WARNING DANGEROUS GAS .....          | 1           | S-4984                  |
| 13         | 8700611904      | DECAL; DANGER ELECTRICAL SHOCK HAZ. ....    | 1           | S-4985                  |

# GA-6H/GA-6HA — GENERATOR ASSY.

GENERATOR ASSY.

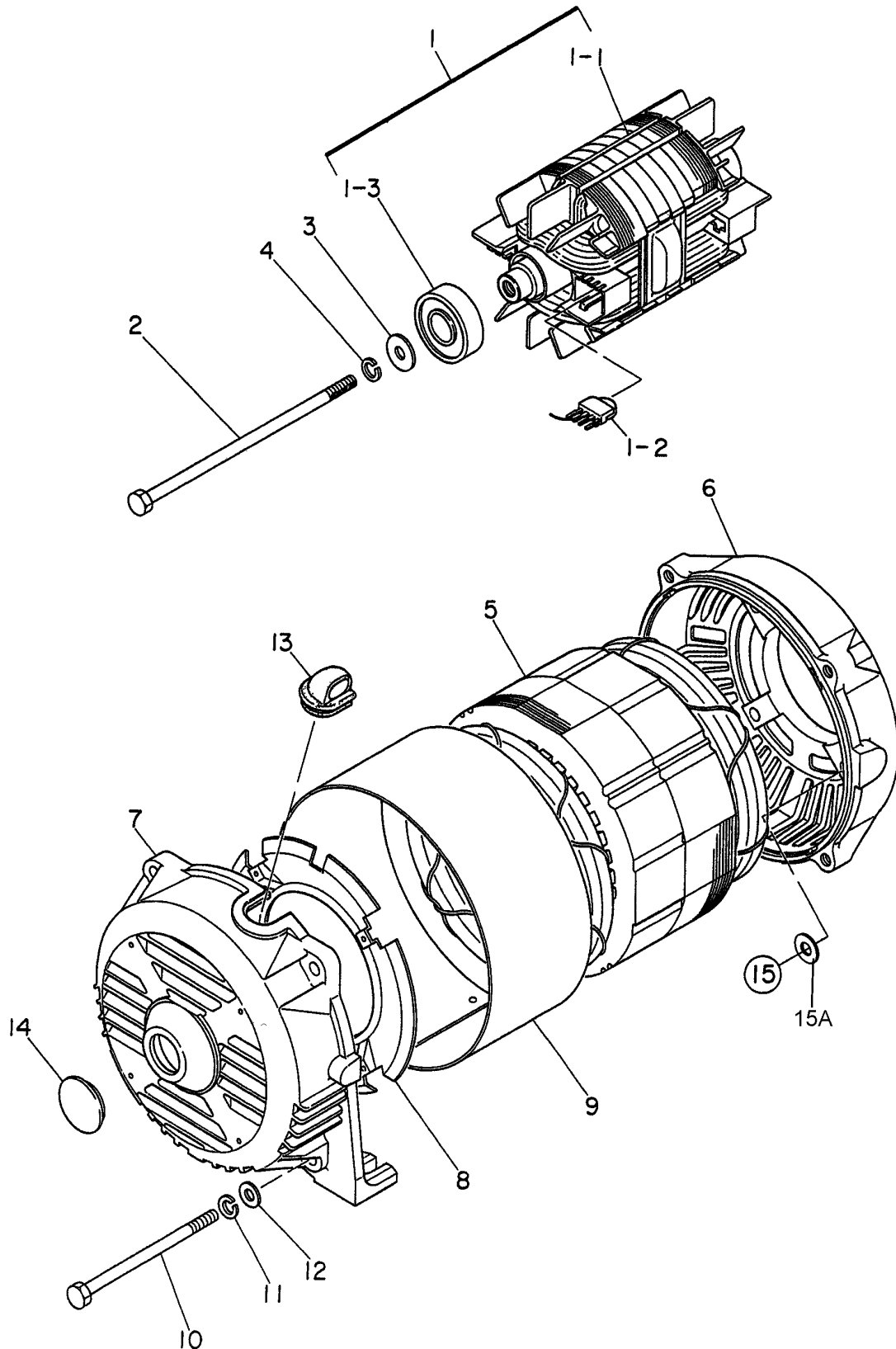

# GA-6H/GA-6HA — GENERATOR ASSY.

## GENERATOR ASSY.

| <u>NO.</u> | <u>PART NO.</u> | <u>PART NAME</u>       | <u>QTY.</u> | <u>REMARKS</u>      |
|------------|-----------------|------------------------|-------------|---------------------|
| 1          | 7901002403      | ROTOR ASSY. ....       | 1           | INCLUDES ITEMS W/*  |
| 1-1*       |                 | FIELD ASSY. ....       | 1           | NOT SOLD SEPERATELY |
| 1-2*       | 0601823213      | RECTIFIER, D3SB80      | 2           |                     |
|            | 0601822638      | SURGE ABSORBER, .....  | 2           | TNR15G431K          |
| 1-3*       | 0071706304      | BEARING, 6304 2RU NYCM | 1           |                     |
| 2          | 7901017004      | SET BOLT, ROTOR        | 1           |                     |
| 3          | 0801086104      | SET WASHER, BEARING    | 1           |                     |
| 4          | 0040010000      | SPRING WASHER          | 1           |                     |
| 5          | A5135000103     | ARMATURE ASSY.         | 1           |                     |
| 6          | 7901315502      | END BRACKET            | 1           |                     |
| 7          | 7871315022      | END BRACKET            | 1           |                     |
| 8          | 7875021523      | GUIDE PANEL, AIR       | 1           |                     |
| 9          | 7871331003      | COVER                  | 1           |                     |
| 10         | 7901316004      | SET BOLT, STATOR       | 4           |                     |
| 11         | 0040008000      | SPRING WASHER          | 4           |                     |
| 12         | 0041208000      | PLAIN WASHER           | 4           |                     |
| 13         | 7871329514      | GROMMET                | 1           |                     |
| 14         | 0601851760      | CAP, 0B-13             | 1           |                     |
| 15         | 0013608020      | HEX, HEAD BOLT         | 4           |                     |
| 15A        | 0040008000      | SPRING WASHER          | 4           |                     |

# GA-6H — CONTROL BOX ASSY.

CONTROL BOX ASSY. (GA-6H)

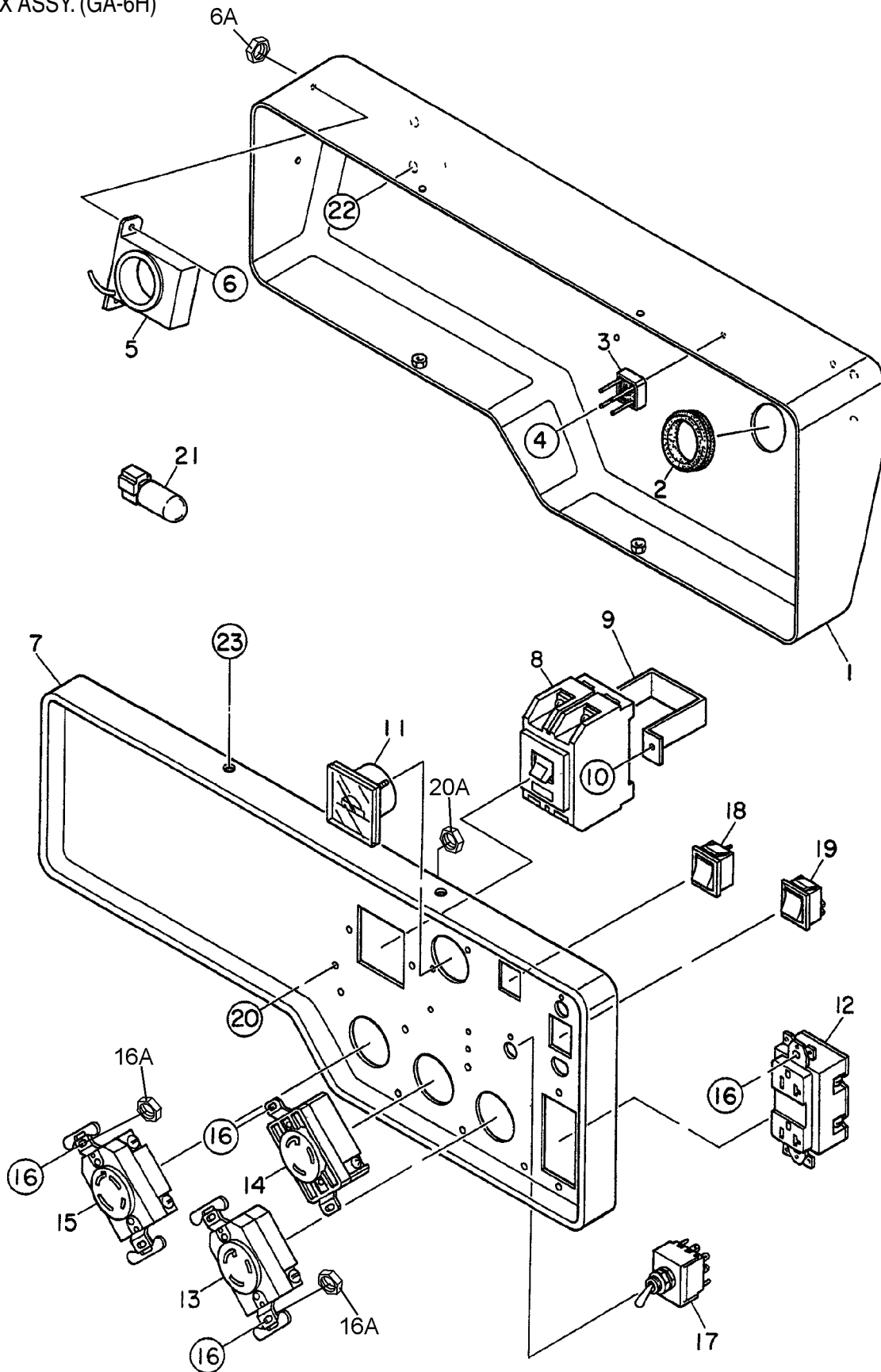

## GA-6H — CONTROL BOX ASSY.

### CONTROL BOX ASSY. (GA-6H)

| <u>NO.</u> | <u>PART NO.</u> | <u>PART NAME</u>                              | <u>QTY.</u> | <u>REMARKS</u> |
|------------|-----------------|---|-------------|----------------|
| 1          | A3214000003     | CONTROL BOX                                   | 1           |                |
| 2          | 0601850102      | GROMMET, G-3                                  | 1           |                |
| 3          | 0601823204      | RECTIFIER, S5VB60                             | 2           |                |
| 4          | 0027103012      | MACHINE SCREW                                 | 2           |                |
| 5          | 0601823853      | SLOW DOWN UNIT, ND-80                         | 1           |                |
| 6          | 0027104010      | MACHINE SCREW                                 | 2           |                |
| 6A         | 0207004000      | HEX, NUT                                      | 2           |                |
| 7          | A3224000003     | CONTROL PANEL                                 | 1           |                |
| 8          | 0601804819      | CIRCUIT BREAKER, KM-2 21A                     | 1           |                |
| 9          | 4341817004      | BRACKET, CIRCUIT BREAKER                      | 1           |                |
| 10         | 0021004010      | MACHINE SCREW                                 | 2           |                |
| 11         | 0601806819      | AC VOLTMETER, DE450-011 0~120/240V            | 1           |                |
| 12         | 0601812598      | RECEPTACLE, 5-20R                             | 1           |                |
| 13         | 0601812592      | RECEPTACLE, L5-20R                            | 1           |                |
| 14         | 0601811035      | RECEPTACLE, LS-30R                            | 1           |                |
| 15         | 0601812529      | RECEPTACLE, L14-30R                           | 1           |                |
| 16         | 0021004010      | MACHINE SCREW                                 | 8           |                |
| 16A        | 0207004000      | HEX, NUT                                      | 8           |                |
| 17         | 0601830737      | FULL POWER SWITCH, ET-330D12                  | 1           |                |
| 18         | 0601831620      | IDLE CONTROL SWITCH, C1550WA                  | 1           |                |
| 19         | 0601831620      | OPERATION SWITCH, C1550WA                     | 1           |                |
| 20         | 0021004015      | MACHINE SCREW                                 | 1           |                |
| 20A        | 0207004000      | HEX, NUT                                      | 1           |                |
| 21         | A3262800004     | CAPACITOR ASSY., VR1H102MHA, 50V 1000 $\mu$ F | 1           |                |
| 22         | 0017106016      | HEX, HEAD BOLT                                | 4           |                |
| 23         | 0017105010      | HEX, HEAD BOLT                                | 4           |                |

# GA-6HA — CONTROL BOX ASSY.

CONTROL BOX ASSY.

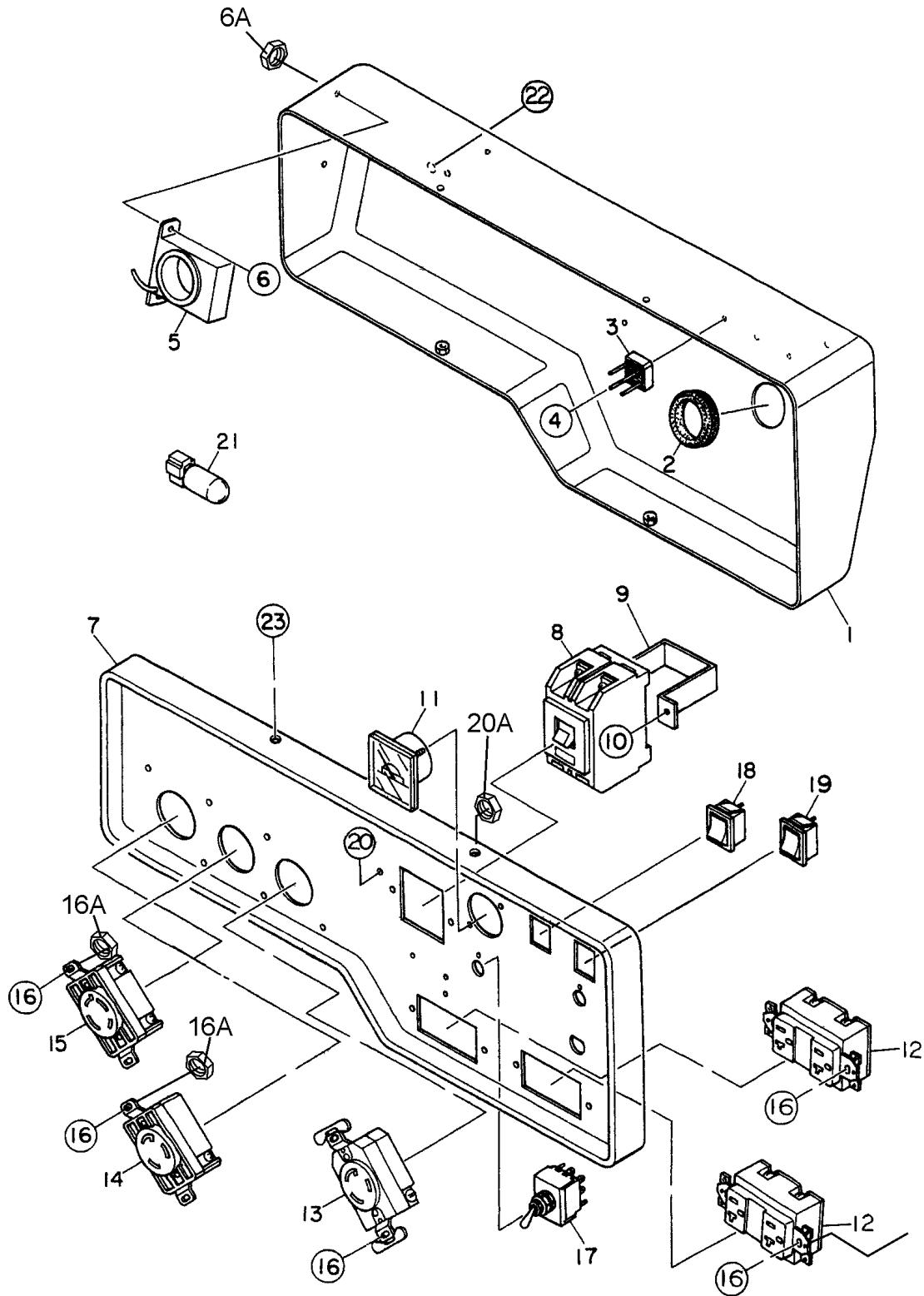

## GA-6HA — CONTROL BOX ASSY.

### CONTROL BOX ASSY.

| <u>NO.</u> | <u>PART NO.</u> | <u>PART NAME</u>                              | <u>QTY.</u> | <u>REMARKS</u> |
|------------|-----------------|---|-------------|----------------|
| 1          | A3214000103     | CONTROL BOX                                   | 1           |                |
| 2          | 0601850102      | GROMMET, G-3                                  | 1           |                |
| 3          | 0601823204      | RECTIFIER, S5VB60                             | 2           |                |
| 4          | 0027103012      | MACHINE SCREW                                 | 2           |                |
| 5          | 0601823853      | SLOW DOWN UNIT, ND-80                         | 1           |                |
| 6          | 0027104010      | MACHINE SCREW                                 | 2           |                |
| 6A         | 0207004000      | HEX, NUT                                      | 2           |                |
| 7          | A3224000103     | CONTROL PANEL                                 | 1           |                |
| 8          | 0601804819      | CIRCUIT BREAKER, KM-2 21A                     | 1           |                |
| 9          | 4341817004      | BRACKET, CIRCUIT BREAKER                      | 1           |                |
| 10         | 0021004010      | MACHINE SCREW                                 | 2           |                |
| 11         | 0601806819      | AC VOLTMETER, DE450-011 0~120/240V            | 1           |                |
| 12         | 0601812598      | RECEPTACLE, 5-20R                             | 2           |                |
| 13         | 0601812592      | RECEPTACLE, L5-20R                            | 1           |                |
| 14         | 0601811035      | RECEPTACLE, LS-30R                            | 1           |                |
| 15         | 0601812529      | RECEPTACLE, L14-30R                           | 1           |                |
| 16         | 0021004010      | MACHINE SCREW                                 | 8           |                |
| 16A        | 0207004000      | HEX, NUT                                      | 8           |                |
| 17         | 0601830737      | FULL POWER SWITCH, ET-330D12                  | 1           |                |
| 18         | 0601831620      | IDLE CONTROL SWITCH, C1550WA                  | 1           |                |
| 19         | 0601831620      | OPERATION SWITCH, C1550WA                     | 1           |                |
| 20         | 0021004015      | MACHINE SCREW                                 | 1           |                |
| 20A        | 0207004000      | HEX, NUT                                      | 1           |                |
| 21         | A3262800004     | CAPACITOR ASSY., VR1H102MHA, 50V 1000 $\mu$ F | 1           |                |
| 22         | 0017106016      | HEX, HEAD BOLT                                | 4           |                |
| 23         | 0017105010      | HEX, HEAD BOLT                                | 4           |                |

# GA-6H/GA-6HA — MUFFLER ASSY.

MUFFLER ASSY.

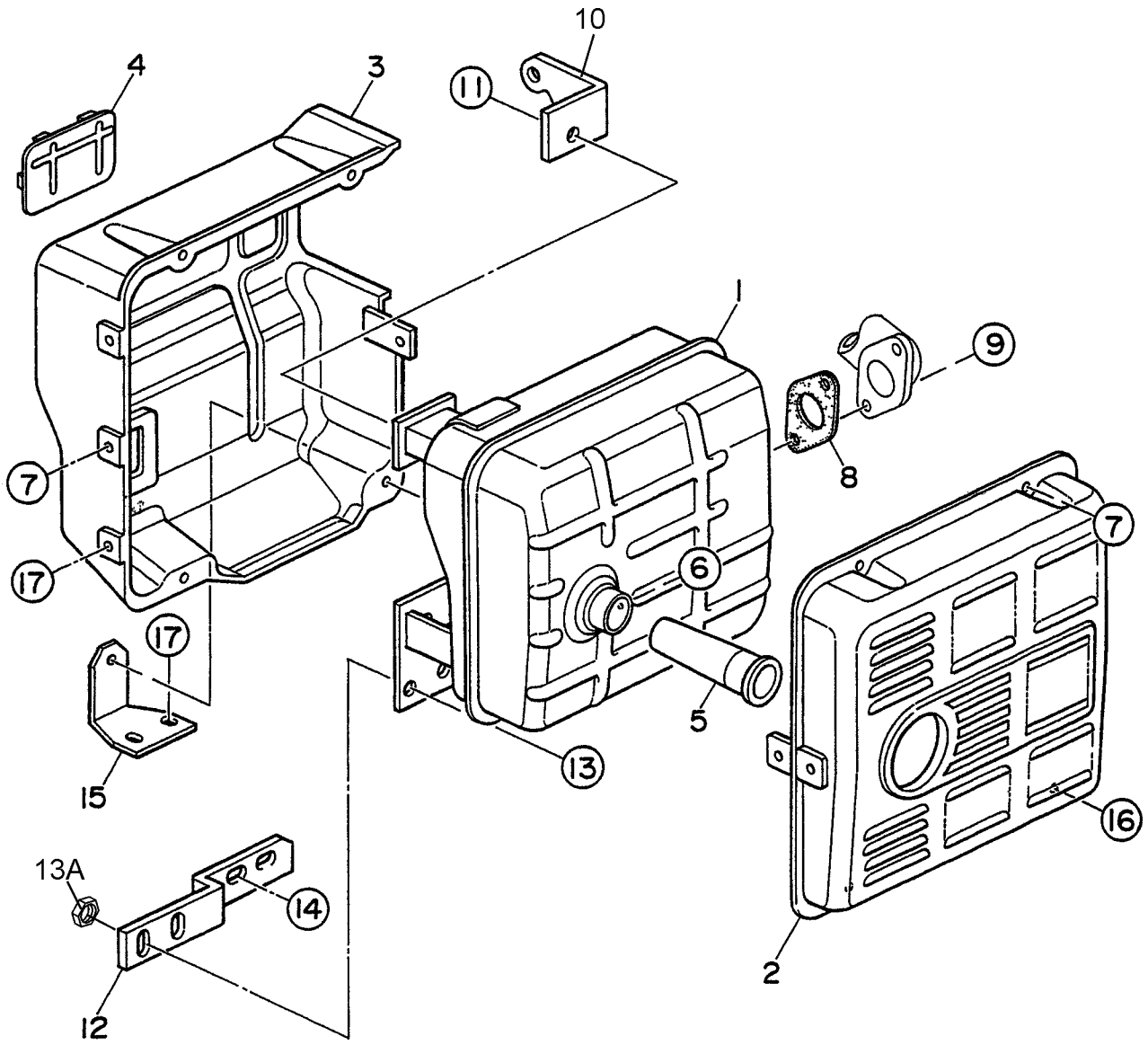



## GA-6H/GA-6HA — MUFFLER ASSY.

### MUFFLER ASSY.

| <u>NO</u> | <u>PART NO</u> | <u>PART NAME</u>      | <u>QTY.</u> | <u>REMARKS</u>          |
|-----------|----------------|-----------------------|-------------|-------------------------|
| 1         | 7912310003     | MUFFLER               | 1           |                         |
| 2         | 18320ZC2000    | PROTECTOR .....       | 1 .....     | REPLACES P/N 0602302001 |
| 3         | 18325ZB4000    | PROTECTOR .....       | 1 .....     | REPLACES P/N 0602302002 |
| 4         | 18329ZB4000    | SEAL .....            | 2 .....     | REPLACES P/N 0602302003 |
| 5         | 8355ZB4630     | ARRESTOR, SPARK ..... | 1 .....     | REPLACES P/N 0602313060 |
| 6         | 90183671003    | TAPPING SCREW .....   | 1 .....     | REPLACES P/N 0602322060 |
| 7         | 0017106012     | BOLT HEX HEAD         | 5           |                         |
| 8         | 18333ZB4800    | GASKET .....          | 1 .....     | REPLACES P/N 0602320175 |
| 9         | 957000802000   | HEX HEAD BOLT .....   | 2 .....     | REPLACES P/N 0602322061 |
| 11        | 0017108020     | BOLT HEX HEAD         | 1           |                         |
| 12        | 7905469004     | BRACKET               | 1           |                         |
| 13        | 0017108025     | BOLT HEX HEAD         | 2           |                         |
| 13A       | 020708000      | HEX NUT               | 2           |                         |
| 14        | 0017108020     | BOLT HEX HEAD         | 1           |                         |
| 15        | 7905469004     | BRACKET               | 1           |                         |
| 16        | 0017106020     | BOLT HEX HEAD         | 1           |                         |
| 17        | 0017106012     | BOLT HEX HEAD         | 4           |                         |

# GA-6H/GA-6HA — PIPE FRAME ASSY.

## PIPE FRAME ASSY.

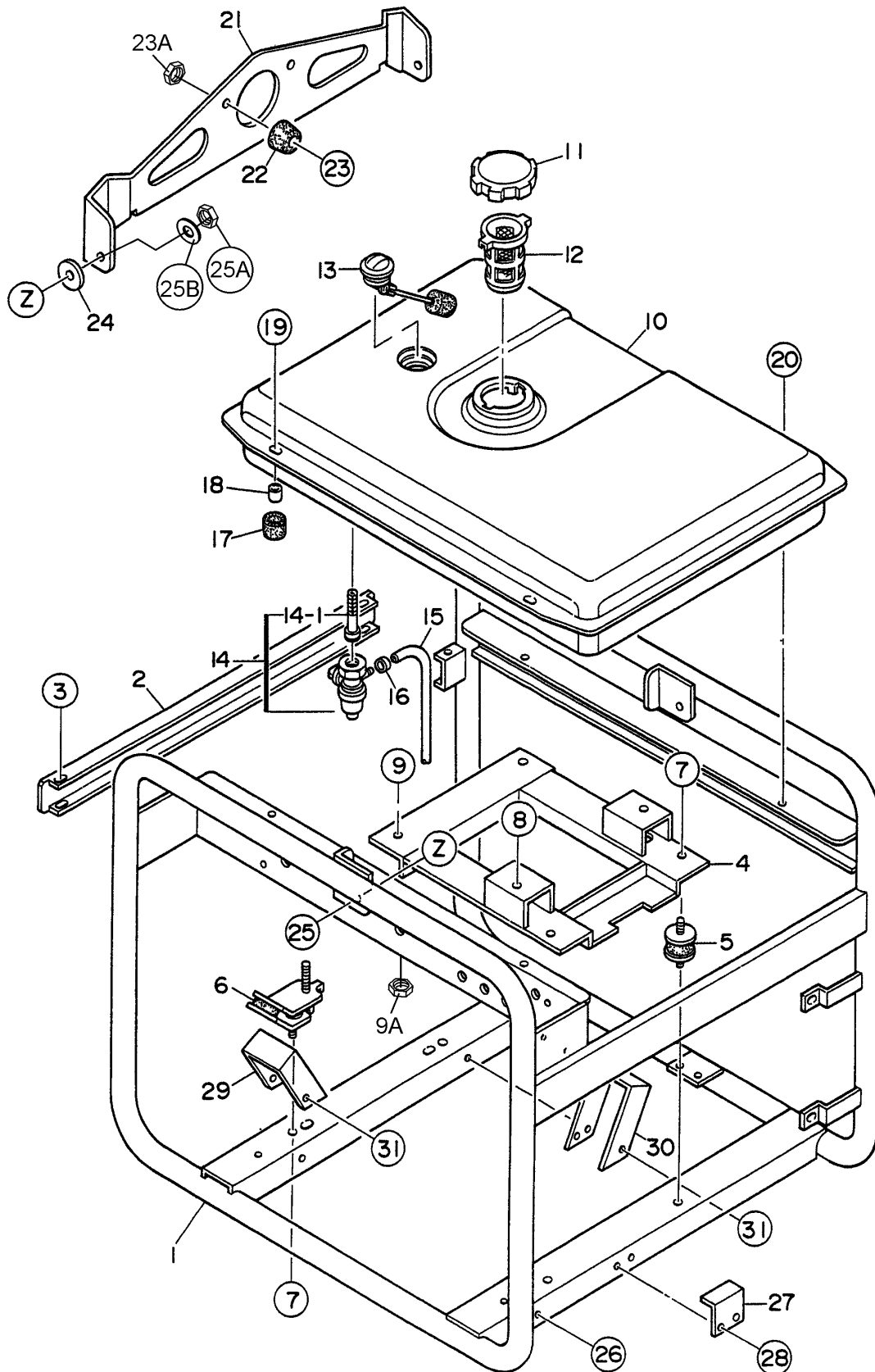

# GA-6H/GA-6HA — PIPE FRAME ASSY.

## PIPE FRAME ASSY.

| <u>NO.</u> | <u>PART NO.</u> | <u>PART NAME</u>        | <u>QTY.</u> | <u>REMARKS</u>          |
|------------|-----------------|-------------------------|-------------|-------------------------|
| 1          | A5417000002     | PIPE FRAME .....        | 1 .....     | GA-6H                   |
| 1          | A5417000402     | PIPE FRAME .....        | 1 .....     | GA-6HA                  |
| 2          | A3417100004     | BRACKET                 | 1           |                         |
| 3          | 0017106016      | HEX, HEAD BOLT          | 4           |                         |
| 4          | 7905443003      | BASE                    | 1           |                         |
| 5          | 3015419604      | RUBBER SUSPENSION       | 2           |                         |
| 6          | 1725419214      | RUBBER SUSPENSION       | 2           |                         |
| 7          | 0207008000      | HEX, NUT                | 8           |                         |
| 8          | 0017108030      | HEX, HEAD BOLT          | 2           |                         |
| 9          | 0017108040      | HEX, HEAD BOLT          | 2           |                         |
| 9A         | 0207008000      | HEX, NUT                | 2           |                         |
| 10         | 7905512002      | FUEL TANK               | 1           |                         |
| 11         | A9924800014     | CAP, FUEL TANK          | 1           |                         |
| 12         | A9924800004     | FUEL FILTER             | 1           |                         |
| 13         | 0602125034      | FUEL GAUGE              | 1           |                         |
| 14         | 16950ZB4015     | FUEL STRAINER .....     | 1 .....     | REPLACES P/N 0605510068 |
| 14-1       | 16952ZB4005     | SCREEN SET, HONDA ..... | 1 .....     | REPLACES P/N 0605510069 |
| 15         | 950014521040    | HOSE, HONDA .....       | 1 .....     | REPLACES P/N 0605513146 |
| 16         | 9500202080      | HOSE BAND, HONDA .....  | 2 .....     | REPLACES P/N 0605515178 |
| 17         | 7855525514      | RUBBER CUSHION          | 2           |                         |
| 18         | 7855525604      | COLLAR                  | 2           |                         |
| 19         | 011208030       | BOLT HEX HEAD           | 2           |                         |
| 20         | 0017108020      | BOLT HEX HEAD           | 2           |                         |
| 21         | A9117200103     | HANGER                  | 1           |                         |
| 22         | 0601850097      | STOPPER, 30029          | 1           |                         |
| 23         | 0021008025      | MACHINE SCREW           | 1           |                         |
| 23A        | 0207008000      | HEX, NUT                | 1           |                         |
| 24         | A931110004      | PLASTIC WASHER .....    | 2 .....     | GA-6H                   |
| 24         | 0601851116      | PLASTIC WASHER .....    | 2 .....     | GA-6HA                  |
| 25         | 0011308025      | HEX, HEAD BOLT          | 2           |                         |
| 25A        | 0037908000      | HEX, NUT                | 2           |                         |
| 25B        | 0042108000      | PLAIN WASHER            | 2           |                         |
| 26         | 0019206016      | HEX, HEAD BOLT          | 1           |                         |
| 27         | 7915456004      | STOPPER                 | 1           |                         |
| 28         | 0017106016      | HEX, HEAD BOLT          | 2           |                         |
| 29         | 7915455103      | COVER                   | 1           |                         |
| 30         | 55455003        | COVER                   | 1           |                         |
| 31         | 0017106016      | HEX, HEAD BOLT          | 6           |                         |

# HONDA GX340K1EDE2 ENGINE — AIR CLEANER ASSY.

AIR CLEANER ASSY.

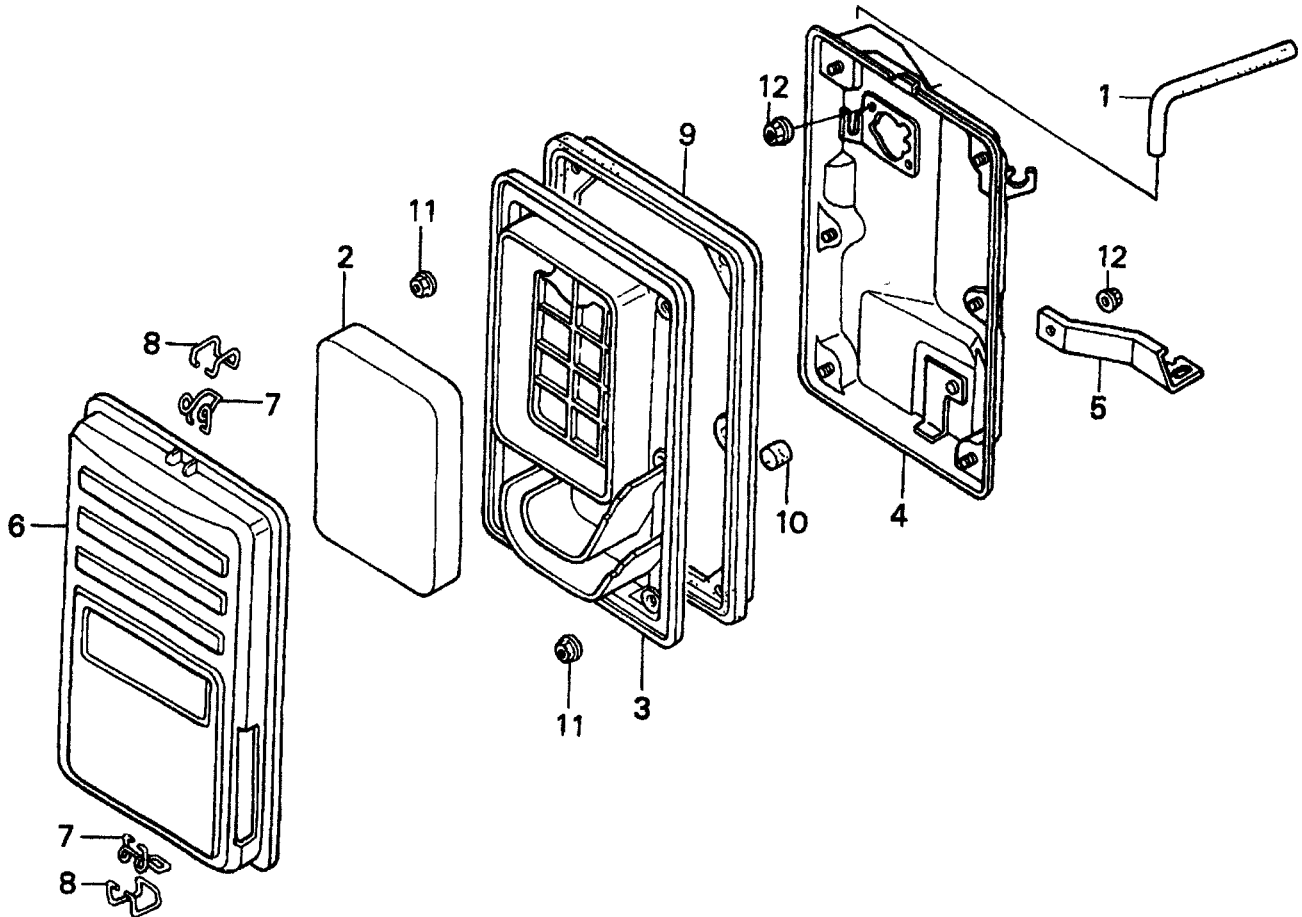

# HONDA GX340K1EDE2 ENGINE — AIR CLEANER ASSY.

## AIR CLEANER ASSY.

| <u>NO.</u> | <u>PART NO.</u> | <u>PART NAME</u>         | <u>QTY.</u> | <u>REMARKS</u> |
|------------|-----------------|--------------------------|-------------|----------------|
| 1          | 15721ZB4000     | TUBE BREATHER            | 1           |                |
| 2          | 17211899000     | ELEMENT, AIR CLEANER     | 1           |                |
| 3          | 17212ZB4003     | SEPARATOR, AIR CLEANER   | 1           |                |
| 4          | 17220ZB4003     | HOUSING, AIR CLEANER     | 1           |                |
| 5          | 17222ZC2000     | STAY, AIR CLEANER        | 1           |                |
| 6          | 17231899000     | COVER, AIR CLEANER       | 1           |                |
| 7          | 17235899000     | CLIP A, AIR CLEANER WIRE | 2           |                |
| 8          | 17236899000     | CLIP B, AIR CLEANER WIRE | 2           |                |
| 9          | 17252899000     | SEAL, AIR CLEANER        | 1           |                |
| 10         | 17367413690     | FILTER, DRAIN TUBE       | 1           |                |
| 11         | 9405005000      | NUT, FLANGE (5MM)        | 6           |                |
| 12         | 9405006000      | NUT, FLANGE (6MM)        | 3           |                |

# HONDA GX340K1EDE2 ENGINE — CAMSHAFT ASSY.

CAMSHAFT ASSY.

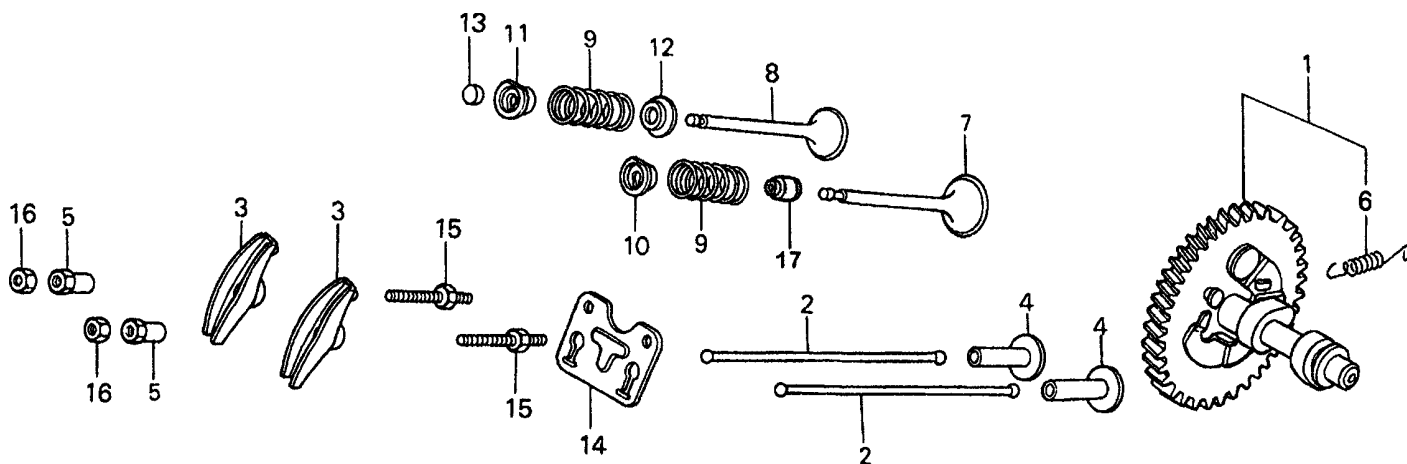

# HONDA GX340K1EDE2 ENGINE — CAMSHAFT ASSY.

## CAMSHAFT ASSY.

| <u>NO.</u> | <u>PART NO.</u> | <u>PART NAME</u>           | <u>QTY.</u> | <u>REMARKS</u>    |
|------------|-----------------|----------------------------|-------------|-------------------|
| 1          | 14100ZE3020     | CAMSHAFT ASSY. ....        | 1           | INCLUDES ITEMS/W* |
| 2          | 14410ZE3013     | ROD, PUSH                  | 2           |                   |
| 3          | 14431ZE2000     | ARM, VALVE ROCKER          | 2           |                   |
| 3          | 14431ZE2010     | ARM, VALVE ROCKER          | 2           |                   |
| 4          | 14441ZE2000     | LIFTER, VALVE              | 2           |                   |
| 5          | 14451ZE1013     | PIVOT, ROCKER ARM          | 2           |                   |
| 6*         | 14568ZE1000     | SPRING, WEIGHT RETURN      | 1           |                   |
| 7          | 14711ZE3000     | VALVE, IN.                 | 1           |                   |
| 8          | 14721ZE3000     | VALVE, EX.                 | 1           |                   |
| 9          | 14751ZE2003     | SPRING, VALVE              | 2           |                   |
| 10         | 14771ZE2000     | RETAINER, IN. VALVE SPRING | 1           |                   |
| 11         | 14773ZE2000     | RETAINER, EX. VALVE SPRING | 1           |                   |
| 12         | 14775ZE2010     | SEAT, VALVE SPRING         | 1           |                   |
| 13         | 14781ZE2000     | ROTATOR, VALVE             | 1           |                   |
| 14         | 14791ZE2010     | PLATE, PUSH ROD GUIDE      | 1           |                   |
| 15         | 90012ZE0010     | BOLT, PIVOT (8MM)          | 2           |                   |
| 16         | 90206ZE1000     | NUT, PIVOT ADJ.            | 2           |                   |

# HONDA GX340K1EDE2 ENGINE — CARBURETOR ASSY.

CARBURETOR ASSY.

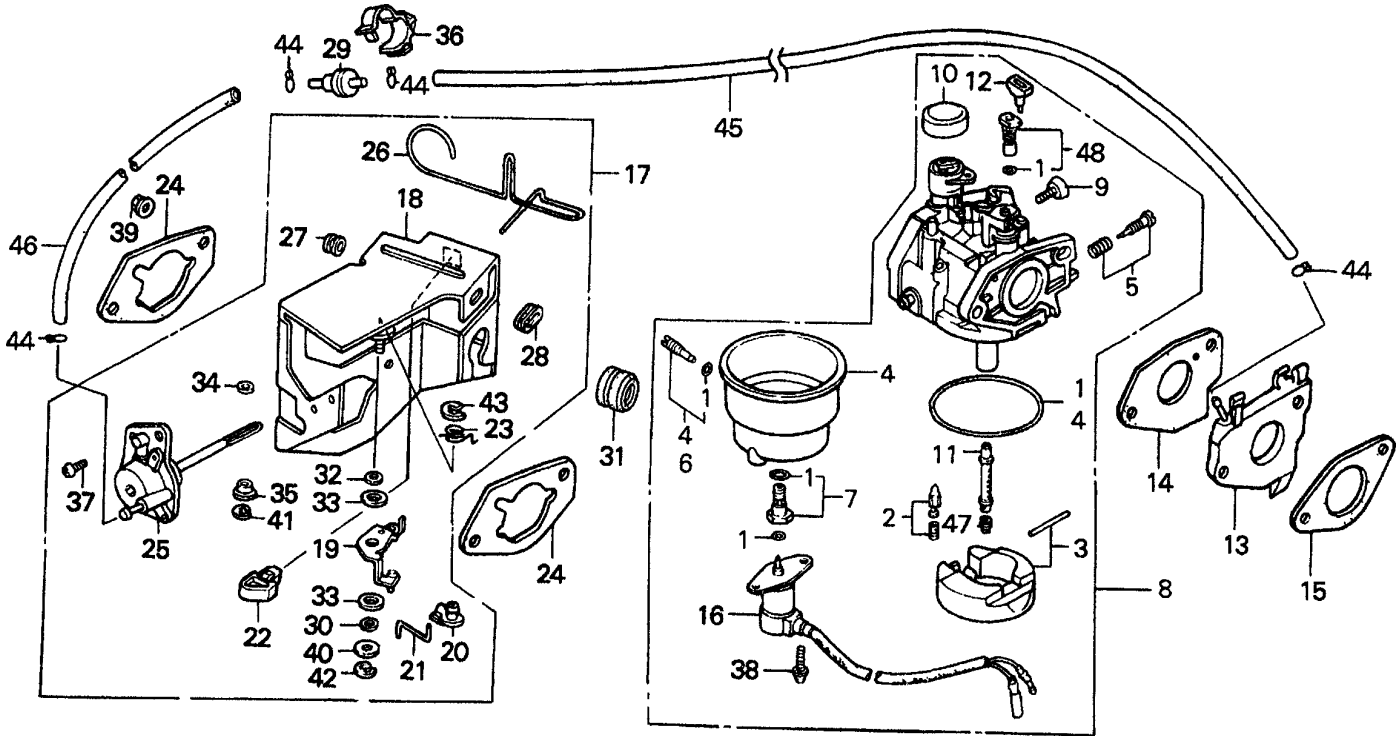



# HONDA GX340K1EDE2 ENGINE — CARBURETOR ASSY.

## CARBURETOR ASSY.

| <u>NO.</u> | <u>PART NO.</u> | <u>PART NAME</u>                       | <u>QTY.</u> | <u>REMARKS</u>     |
|------------|-----------------|--|-------------|--------------------|
| 1*         | 16010ZE3701     | GASKET SET                             | 1           |                    |
| 2*         | 16011ZA0931     | VALVE SET, FLOAT                       | 1           |                    |
| 3*         | 16013ZA0931     | FLOAT SET                              | 1           |                    |
| 4*         | 16015ZA0931     | CHAMBER SET, FLOAT                     | 1           |                    |
| 5*         | 16016ZH7W01     | SCREW SET                              | 1           |                    |
| 6*         | 16024124760     | SCREW SET, DRAIN                       | 1           |                    |
| 7*         | 16028ZA0931     | SCREW SET B                            | 1           |                    |
| 8          | 16100ZE3F11     | CARBURETOR ASSY. (BE82B B) .....       | 1           | INCLUDES ITEMS W/* |
| 9*         | 16124ZE0005     | SCREW, THROTTLE STOP                   | 1           |                    |
| 10*        | 16148141881     | CAP, CHOKE LEVER DUST                  | 1           |                    |
| 11*        | 16166ZE3F10     | NOZZLE, MAIN                           | 1           |                    |
| 12*        | 16172ZE3W10     | COLLAR, SET                            | 1           |                    |
| 13         | 16211ZE3700     | INSULATOR, CARBURETOR                  | 1           |                    |
| 14         | 16221ZE3800     | GASKET, CARBURETOR                     | 1           |                    |
| 15         | 16223ZE3800     | GASKET, INSULATOR                      | 1           |                    |
| 16*        | 16230ZE3701     | VALVE ASSY., SOLENOID                  | 1           |                    |
| 17         | 16260ZE2722     | STAY ASSY., MANUAL CHOKE .....         | 1           | INCLUDES ITEMS W/# |
| 18#        | 16261ZE2702     | STAY, SOLENOID                         | 1           |                    |
| 19#        | 16262ZE2711     | LEVER, CHOKE                           | 1           |                    |
| 20#        | 16263ZA0000     | JOINT, ROD                             | 1           |                    |
| 21#        | 16264ZE2701     | ROD, CHOKE                             | 1           |                    |
| 22#        | 16265ZE2721     | STOPPER, CHOKE ROD                     | 1           |                    |
| 23#        | 16268ZE2721     | SPRING, MANUAL CHOKE                   | 1           |                    |
| 24         | 16269ZA0800     | GASKET, AIR CLEANER                    | 2           |                    |
| 25#        | 16400ZE2703     | DIAPHRAGM ASSY.                        | 1           |                    |
| 26#        | 16611ZE2711     | ROD, CHOKE CONTROL                     | 1           |                    |
| 27#        | 16613893000     | GROMMET, CHOKE ROD                     | 1           |                    |
| 28#        | 16615893000     | GUIDE, CHOKE ROD                       | 1           |                    |
| 29         | 36135ZF6D41     | VALVE, DASHPOT CHECK                   | 1           |                    |
| 30#        | 53149964003     | BUSH, ARM PIVOT                        | 1           |                    |
| 31         | 88911MJ3000     | GROMMET, FENDER                        | 1           |                    |
| 32#        | 90431ZE2700     | WASHER, CHOKE LEVER                    | 1           |                    |
| 33#        | 90432ZE2700     | SEAL, CHOKE LEVER                      | 2           |                    |
| 34#        | 90433ZE2700     | WASHER, THRUST (2.7X8)                 | 1           |                    |
| 35#        | 90434ZE2700     | COLLAR, LEVER                          | 1           |                    |
| 36         | 90650SD9003     | CLIP, WIRE HARNESS                     | 1           |                    |
| 37#        | 93500050120A    | SCREW, PAN (5X12)                      | 2           |                    |
| 38         | 938920501208    | SCREW, WASHER (5X12)                   | 2           |                    |
| 39         | 9405006000      | NUT, FLANGE (6MM)                      | 2           |                    |
| 40#        | 9410305000      | WASHER, PLAIN (5MM)                    | 1           |                    |
| 41#        | 9454002010      | E-RING (2MM)                           | 1           |                    |
| 42#        | 9454004010      | E-RING (4MM)                           | 1           |                    |
| 43#        | 9454007010      | E-RING (7MM)                           | 1           |                    |
| 44         | 9500202070      | CLIP, TUBE (B7)                        | 4           |                    |
| 45         | 950053500810M   | BULK HOSE, VACUUM (3.5X8000) (3.5X75)  | 1           |                    |
| 46         | 950053500810M   | BULK HOSE, VACUUM (3.5X8000) (3.5X130) | 1           |                    |
| 47         | 99101ZH80950    | JET, MAIN (#95) (OPTIONAL)             | 1           |                    |
| 47         | 99101ZH80980    | JET, MAIN (#98) (OPTIONAL)             | 1           |                    |
| 47*        | 99101ZH81000    | JET, MAIN (#100)                       | 1           |                    |
| 48*        | 99204ZE00350    | JET SET, PILOT (#35)                   | 1           |                    |

# HONDA GX340K1EDE2 ENGINE — CONTROL ASSY.

CONTROL ASSY.

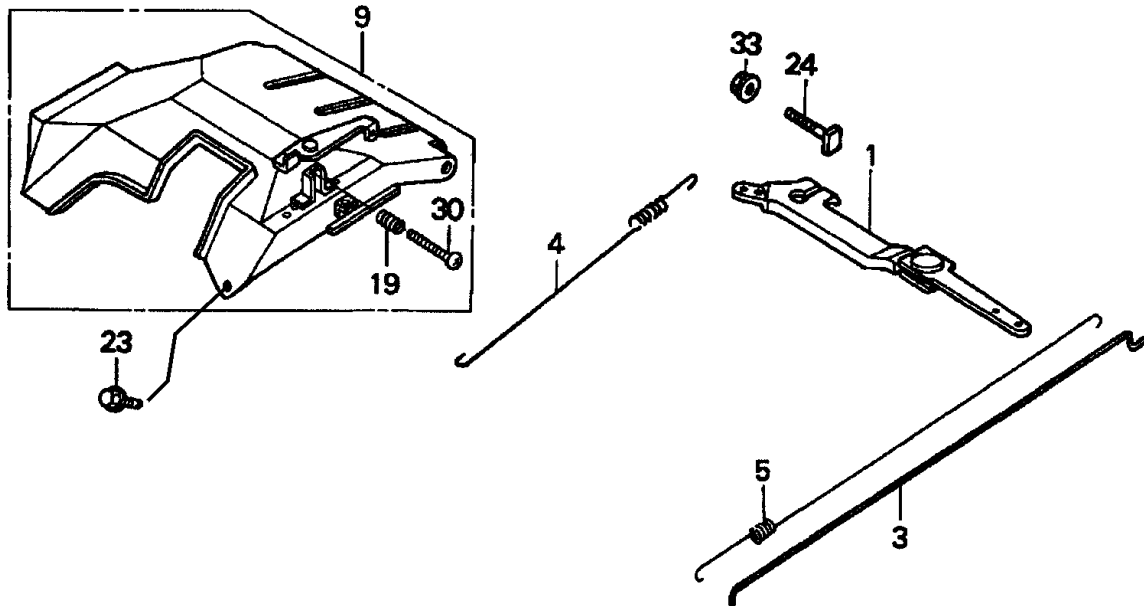

## HONDA GX340K1EDE2 ENGINE — CONTROL ASSY.

### CONTROL ASSY.

| <u>NO.</u> | <u>PART NO.</u> | <u>PART NAME</u>            | <u>QTY.</u> | <u>REMARKS</u>     |
|------------|-----------------|-----------------------------|-------------|--------------------|
| 1          | 16550ZE3700     | ARM, GOVERNOR               | 1           |                    |
| 3          | 16555ZE3000     | ROD, GOVERNOR               | 1           |                    |
| 4          | 16561ZE3000     | SPRING, GOVERNOR            | 1           |                    |
| 5          | 16562ZE3700     | SPRING, THROTTLE RETURN     | 1           |                    |
| 9          | 16570ZE3700     | CONTROL ASSY. ....          | 1           | INCLUDES ITEMS W/* |
| 19*        | 16584883300     | SPRING, CONTROL ADJUSTING   | 1           |                    |
| 23         | 90013883000     | BOLT, FLANGE (6X12) (CT200) | 2           |                    |
| 24         | 90015ZE5010     | BOLT, GOVERNOR ARM          | 1           |                    |
| 30*        | 93500050350A    | SCREW, PAN (5X35)           | 1           |                    |
| 33         | 9405006000      | NUT, FLANGE (6MM)           | 1           |                    |

# HONDA GX340K1EDE2 ENGINE — CRANKCASE COVER ASSY.

CRANKCASE COVER ASSY.

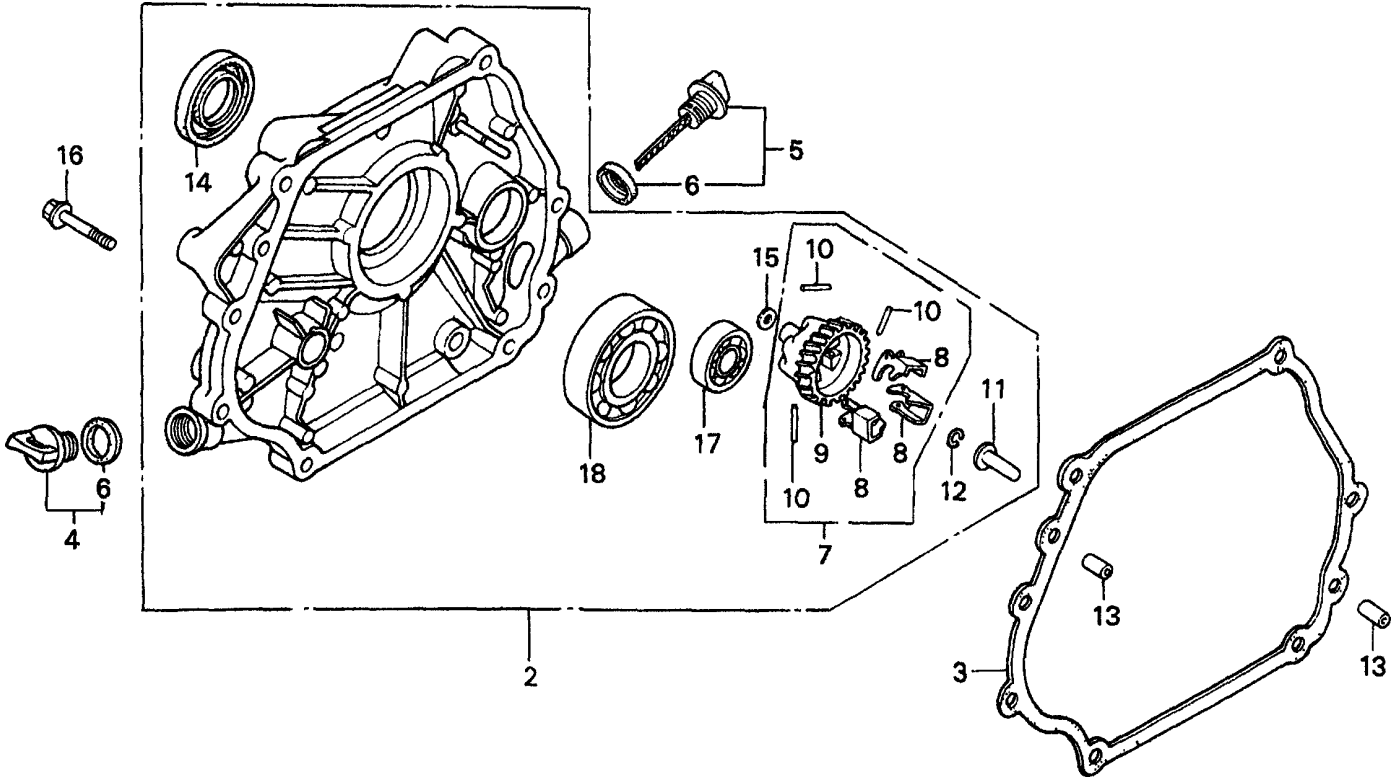

# HONDA GX340K1EDE2 ENGINE — CRANKCASE COVER ASSY.

## CRANKCASE COVER ASSY.

| <u>NO.</u> | <u>PART NO.</u> | <u>PART NAME</u>                      | <u>QTY.</u> | <u>REMARKS</u>     |
|------------|-----------------|---------------------------------------|-------------|--------------------|
| 2          | 11300ZE3020     | COVER ASSY., CRANKCASE (S-TYPE) ..... | 1 .....     | INCLUDES ITEMS W/* |
| 3          | 11381ZE3801     | GASKET, CASE COVER                    | 1           |                    |
| 4          | 15600ZG4003     | CAP ASSY., OIL FILLER .....           | 1 .....     | INCLUDES ITEMS W/% |
| 5          | 15600735003     | CAP ASSY., OIL FILLER .....           | 1 .....     | INCLUDES ITEMS W/% |
| 6%         | 15625ZE1003     | GASKET, OIL FILLER CAP                | 2           |                    |
| 7*         | 16510ZE3000     | GOVERNOR ASSY. ....                   | 1 .....     | INCLUDES ITEMS W/# |
| 8#*        | 16511ZE8000     | WEIGHT, GOVERNOR                      | 3           |                    |
| 9#*        | 16512ZE3000     | HOLDER, GOVERNOR WEIGHT               | 1           |                    |
| 10#*       | 16513ZE2000     | PIN, GOVERNOR WEIGHT                  | 3           |                    |
| 11*        | 16531ZE2000     | SLIDER, GOVERNOR                      | 1           |                    |
| 12*        | 90602ZE1000     | CLIP, GOVERNOR HOLDER                 | 1           |                    |
| 13         | 90701HC4000     | PIN, DOWEL (8X12)                     | 2           |                    |
| 14*        | 92102ZE3004     | OIL SEAL (35X52X8)                    | 1           |                    |
| 15#        | 9410106800      | WASHER, PLAIN (6MM)                   | 1           |                    |
| 16         | 957010804000    | BOLT, FLANGE (8X40)                   | 7           |                    |
| 17*        | 961006202000    | BEARING, RADIAL BALL (6202)           | 1           |                    |
| 18*        | 961006207000    | BEARING, RADIAL BALL (6207)           | 1           |                    |

# HONDA GX340K1EDE2 ENGINE — CRANKSHAFT ASSY.

CRANKSHAFT ASSY.

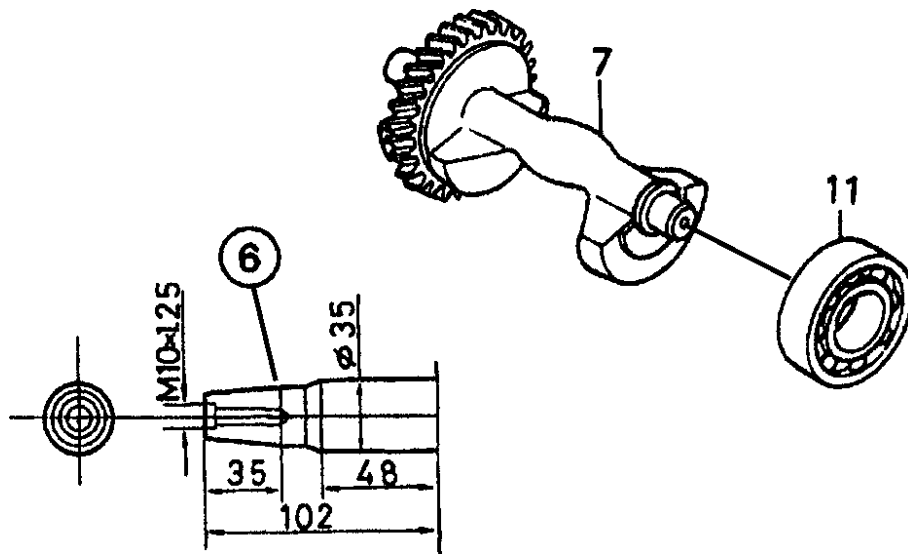

## HONDA GX340K1EDE2 ENGINE — CRANKSHAFT ASSY.

CRANKSHAFT ASSY.

| <u>NO.</u> | <u>PART NO.</u> | <u>PART NAME</u>            | <u>QTY.</u> | <u>REMARKS</u> |
|------------|-----------------|-----------------------------|-------------|----------------|
| 6          | 13310ZE3701     | CRANKSHAFT (E-TYPE)         | 1           |                |
| 7          | 13351ZE3010     | WEIGHT, BALANCER            | 1           |                |
| 11         | 961006207000    | BEARING, RADIAL BALL (6207) | 1           |                |

# HONDA GX340K1EDE2 ENGINE — CYLINDER BARREL ASSY.

CYLINDER BARREL ASSY.

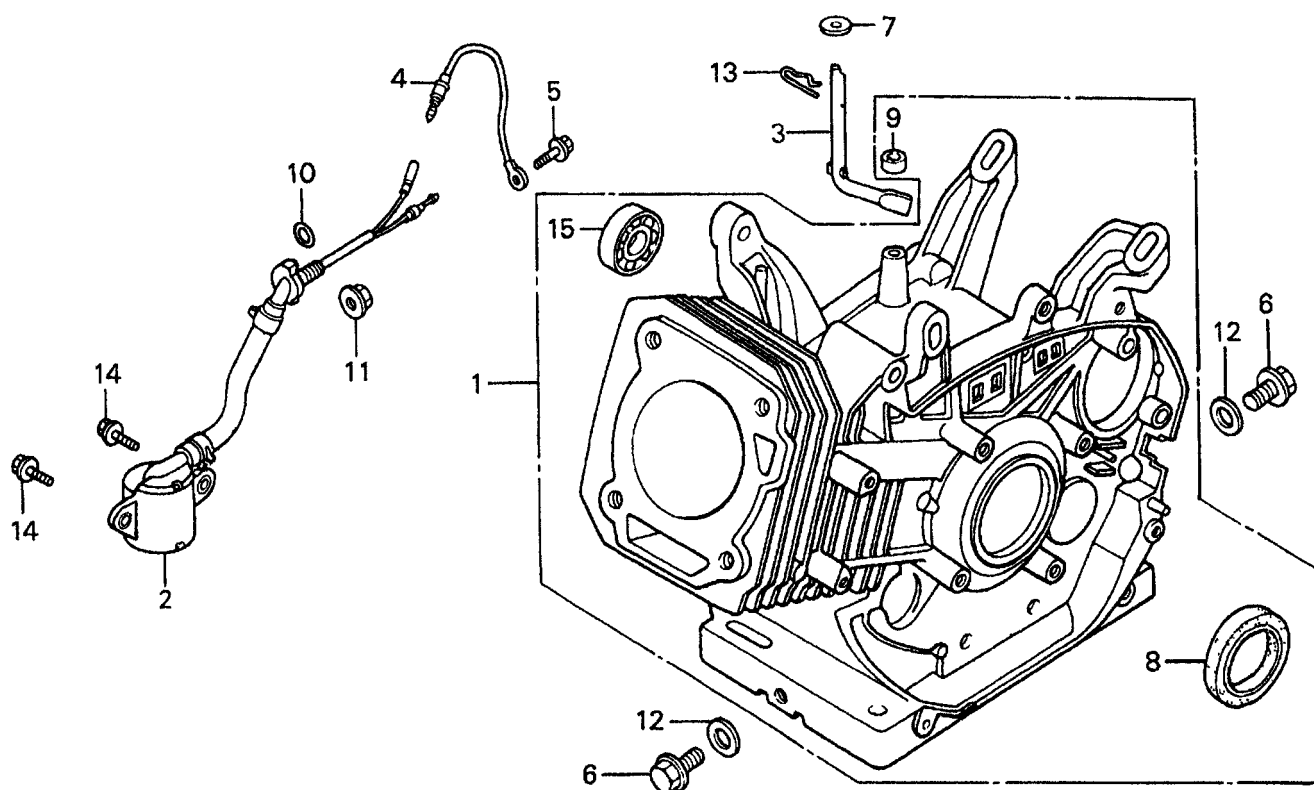



# HONDA GX340K1EDE2 ENGINE — CYLINDER BARREL ASSY.

## CYLINDER BARREL ASSY.

| <u>NO.</u> | <u>PART NO.</u> | <u>PART NAME</u>             | <u>QTY.</u> | <u>REMARKS</u>     |
|------------|-----------------|------------------------------|-------------|--------------------|
| 1          | 12000ZE3817     | CYLINDER ASSY. (ALERT) ..... | 1 .....     | INCLUDES ITEMS W/* |
| 2          | 15510ZE2043     | SWITCH ASSY., OIL LEVEL      | 1           |                    |
| 3          | 16541ZE3010     | SHAFT, GOVERNOR ARM          | 1           |                    |
| 4          | 31161ZE2000     | WIRE, GROUND                 | 1           |                    |
| 5          | 90013883000     | BOLT, FLANGE (6X12) (CT200)  | 1           |                    |
| 6          | 90131896650     | BOLT, DRAIN PLUG             | 2           |                    |
| 7          | 90446KE1000     | WASHER (8.2X17X0.8)          | 1           |                    |
| 8*         | 91201ZE3004     | OIL SEAL (35X52X8)           | 1           |                    |
| 9*         | 91203952771     | OIL SEAL (8X14X5)            | 1           |                    |
| 10         | 91353671003     | O-RING (13.5X1.5) (ARAI)     | 1           |                    |
| 11         | 9405010000      | NUT, FLANGE (10MM)           | 1           |                    |
| 12         | 9410912000      | WASHER, DRAIN PLUG (12MM)    | 2           |                    |
| 13         | 9425110000      | PIN, LOCK (10MM)             | 1           |                    |
| 14         | 957010601200    | BOLT FLANGE (6X12)           | 2           |                    |
| 15*        | 961006202000    | BEARING, RADIAL BALL (6202)  | 1           |                    |

# HONDA GX340K1EDE2 ENGINE — CYLINDER HEAD ASSY.

CYLINDER HEAD ASSY.

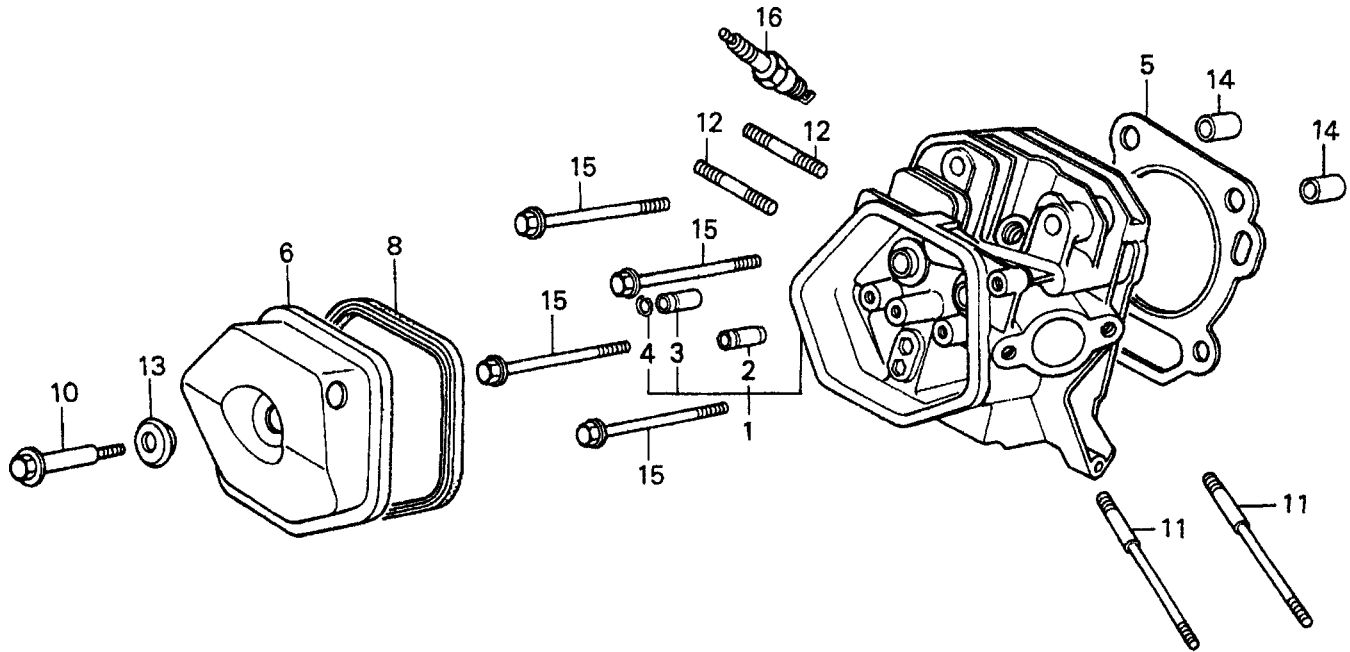

# HONDA GX340K1EDE2 ENGINE — CYLINDER HEAD ASSY.

## CYLINDER HEAD ASSY.

| <u>NO.</u> | <u>PART NO.</u> | <u>PART NAME</u>                     | <u>QTY.</u> | <u>REMARKS</u>     |
|------------|-----------------|--------------------------------------|-------------|--------------------|
| 1          | 12200ZF6W01     | CYLINDER HEAD .....                  | 1           | INCLUDES ITEMS W/* |
| 2          | 12204ZE2306     | GUIDE, VALVE (OS) (OPTIONAL)         | 1           |                    |
| 3*         | 12205ZE2305     | GUIDE, EX. VALVE (OS) (OPTIONAL)     | 1           |                    |
| 4*         | 12216ZE2300     | CLIP, VALVE GUIDE                    | 1           |                    |
| 5          | 12251ZE3W00     | GASKET, CYLINDER HEAD                | 1           |                    |
| 6          | 12310ZE2020     | COVER, HEAD                          | 1           |                    |
| 8          | 12391ZE2020     | GASKET, CYLINDER HEAD COVER          | 1           |                    |
| 10         | 90014ZE2000     | BOLT, HEAD COVER                     | 1           |                    |
| 11         | 90042ZE3700     | BOLT, STUD (8X106)                   | 2           |                    |
| 12         | 92900080320E    | BOLT 2, STUD (8X32)                  | 2           |                    |
| 13         | 90441ZE2010     | WASHER, HEAD COVER                   | 1           |                    |
| 14         | 9430112200      | PIN A, DOWEL (12X20)                 | 2           |                    |
| 15         | 957011008000    | BOLT, FLANGE (10X80)                 | 4           |                    |
| 16         | 9807955846      | SPARK PLUG (BPR5ES) (NGK) (OPTIONAL) | 1           |                    |
| 16         | 9807955855      | SPARK PLUG (W16EPR-U) (DENSO)        | 1           |                    |

# HONDA GX340K1EDE2 ENGINE — FAN COVER ASSY.

FAN COVER ASSY.

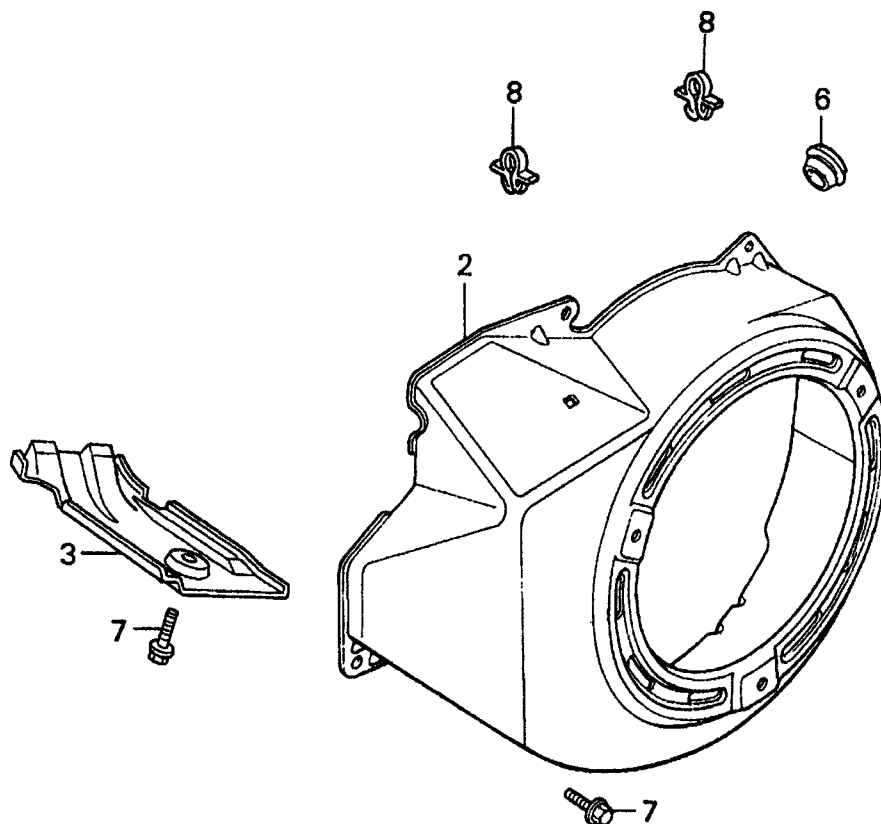

## HONDA GX340K1EDE2 ENGINE — FAN COVER ASSY.

FAN COVER ASSY.

| <u>NO.</u> | <u>PART NO.</u> | <u>PART NAME</u>                 | <u>QTY.</u> | <u>REMARKS</u> |
|------------|-----------------|----------------------------------|-------------|----------------|
| 2          | 19610ZE3700ZB   | COVER, FAN *NH1* (BLACK)         | 1           |                |
| 3          | 19631ZE3W00     | SHROUD                           | 1           |                |
| 6          | 81329567020     | GROMMET, DRAIN HOLE              | 1           |                |
| 7          | 90013883000     | BOLT, FLANGE (6X12) (CT200)      | 6           |                |
| 8          | 90654SA4003     | CLIP, WIRE HARNESS (6MM) (WHITE) | 2           |                |

# HONDA GX340K1EDE2 ENGINE — FLYWHEEL ASSY.

FLYWHEEL ASSY.

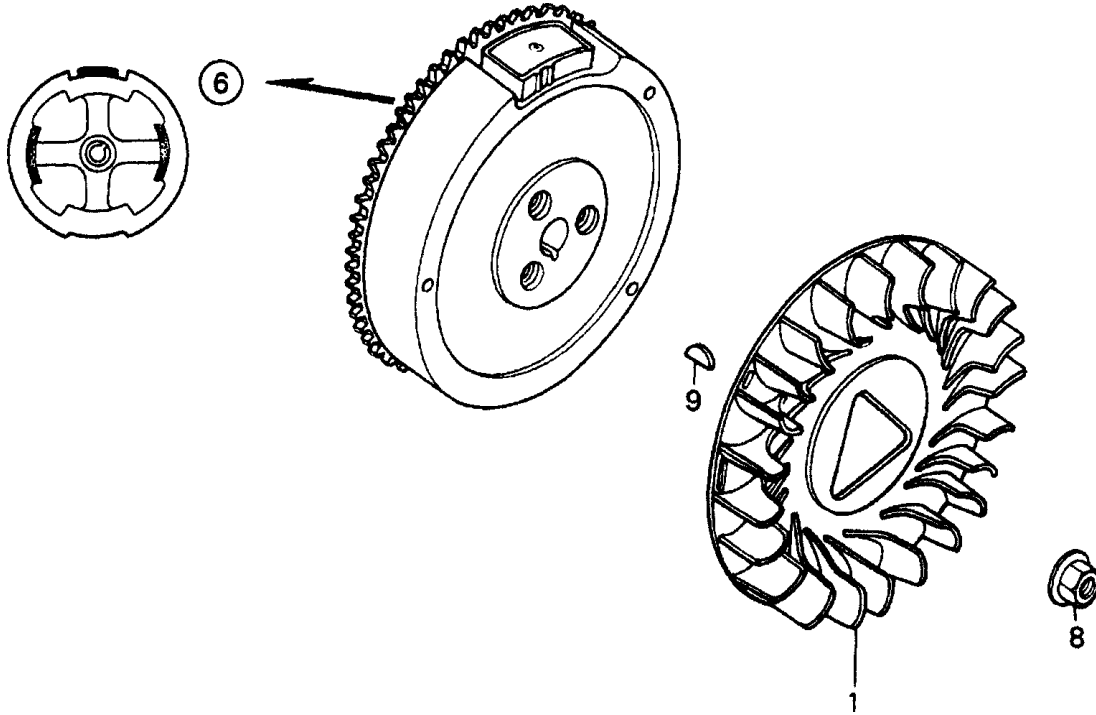

# HONDA GX340K1EDE2 ENGINE — FLYWHEEL ASSY.

FLYWHEEL ASSY.

| <u>NO.</u> | <u>PART NO.</u> | <u>PART NAME</u>              | <u>QTY.</u> | <u>REMARKS</u> |
|------------|-----------------|-------------------------------|-------------|----------------|
| 1          | 19511ZE3000     | FAN, COOLING                  | 1           |                |
| 6          | 31100ZE3712     | FLYWHEEL, LAMP                | 1           |                |
| 8          | 90201ZE3V00     | NUT, SPECIAL 16MM             | 1           |                |
| 9          | 90741ZE2000     | KEY, SPECIAL WOODRUFF (25X18) | 1           |                |

# HONDA GX340K1EDE2 ENGINE — IGNITION COIL ASSY.

IGNITION COIL ASSY.

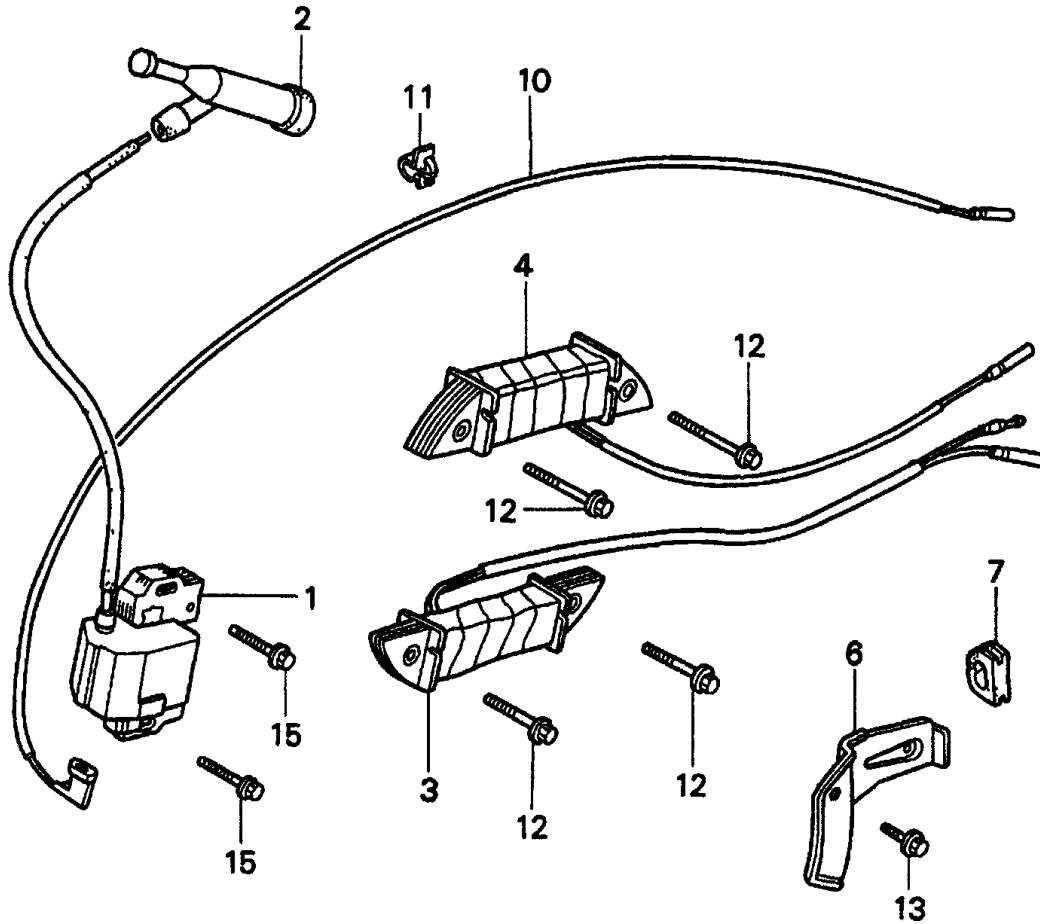



## HONDA GX340K1EDE2 ENGINE — IGNITION COIL ASSY.

### IGNITION COIL ASSY.

| <u>NO.</u> | <u>PART NO.</u> | <u>PART NAME</u>            | <u>QTY.</u> | <u>REMARKS</u> |
|------------|-----------------|-----------------------------|-------------|----------------|
| 1          | 30500ZE2023     | COIL ASSY., IGNITION        | 1           |                |
| 2          | 30700ZE1013     | CAP ASSY., NOISE SUPPRESSOR | 1           |                |
| 3          | 31510ZE1811     | COIL ASSY., LAMP (12V/25W)  | 1           |                |
| 4          | 31510ZE3003     | COIL ASSY., LAMP (12V/25W)  | 1           |                |
| 6          | 31511ZE3000     | CLAMP, WIRE                 | 1           |                |
| 7          | 31512ZE2000     | GROMMET, WIRE               | 1           |                |
| 10         | 36101ZE3800     | WIRE, STOP SWITCH (470MM)   | 1           |                |
| 11         | 36103ZE1000     | HOLDER, STOP SWITCH WIRE    | 1           |                |
| 12         | 90012888000     | BOLT, FLANGE (6X40)         | 4           |                |
| 13         | 90013883000     | BOLT, FLANGE (6X12) (CT200) | 1           |                |
| 15         | 90015883000     | BOOT, FLANGE (6X28)         | 2           |                |

# HONDA GX340K1EDE2 ENGINE — PISTON ASSY.

PISTON ASSY.

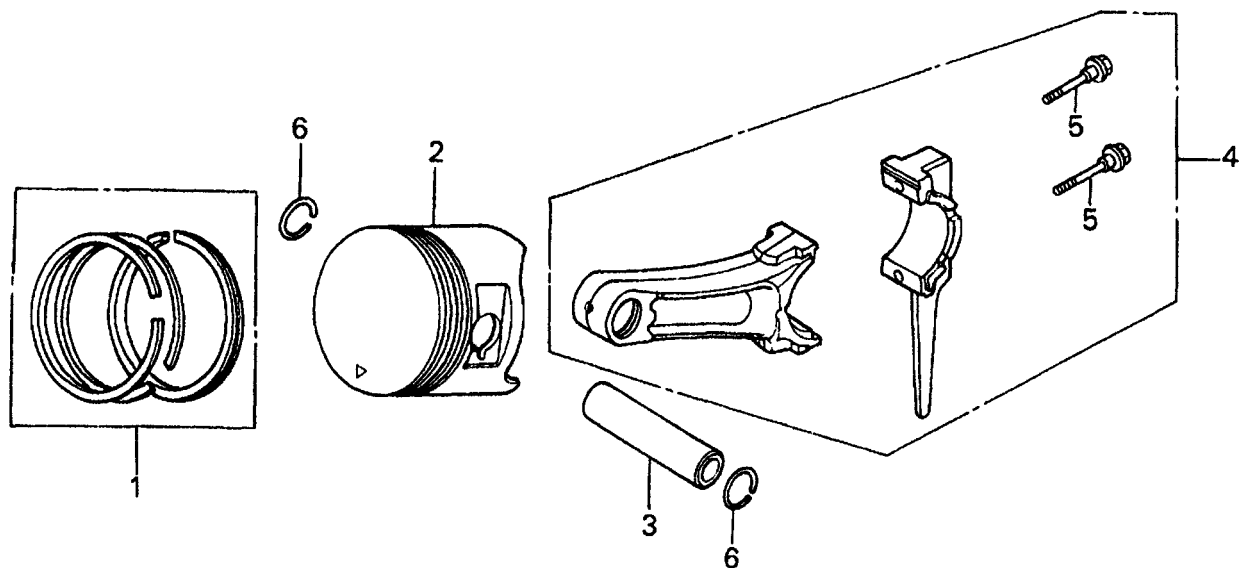

# HONDA GX340K1EDE2 ENGINE — PISTON ASSY.

PISTON ASSY.

| <u>NO.</u> | <u>PART NO.</u> | <u>PART NAME</u>                      | <u>QTY.</u> | <u>REMARKS</u>     |
|------------|-----------------|---------------------------------------|-------------|--------------------|
| 1          | 13010ZE3003     | RING SET, PISTON (STD)                | 1           |                    |
| 1          | 13011ZE3003     | RING SET, PISTON (OS 0.25) (OPTIONAL) | 1           |                    |
| 1          | 13012ZE3003     | RING SET, PISTON (OS 0.50) (OPTIONAL) | 1           |                    |
| 1          | 13013ZE3003     | RING SET, PISTON (0.75) (OPTIONAL)    | 1           |                    |
| 2          | 13101ZE3W00     | PISTON (STD)                          | 1           |                    |
| 3          | 13111ZF6000     | PIN, PISTON                           | 1           |                    |
| 4          | 13200ZE3010     | ROD ASSY., CONNECTING (STD) .....     | 1           | INCLUDES ITEMS W/* |
| 5*         | 90001ZE8000     | BOLT, CONNECTING ROD                  | 2           |                    |
| 6          | 90601ZE3000     | CLIP, PISTON PIN (20MM)               | 2           |                    |

# HONDA GX340K1EDE2 ENGINE — RECOIL STARTER ASSY.

RECOIL STARTER ASSY.

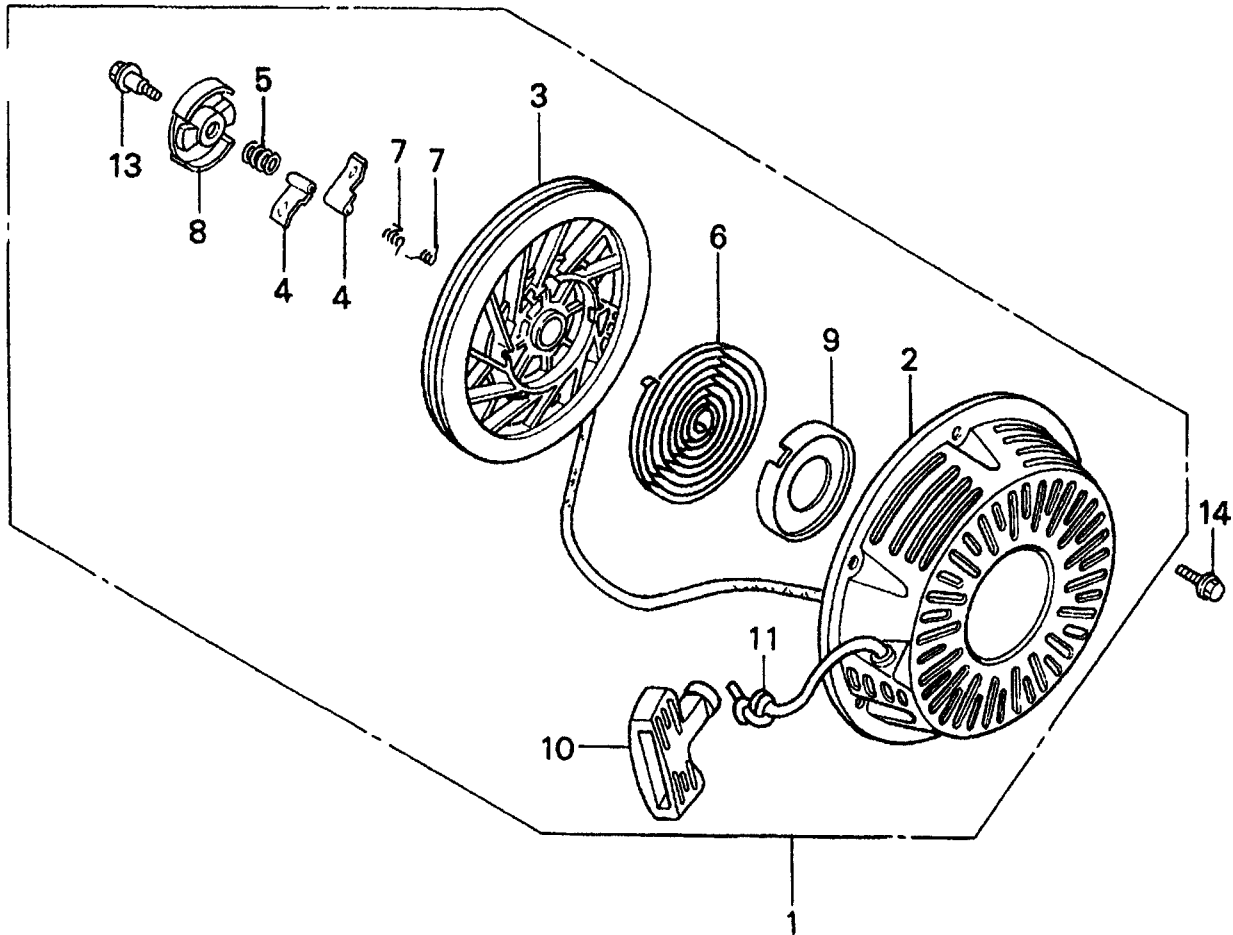

# HONDA GX340K1EDE2 ENGINE — RECOIL STARTER ASSY.

## RECOIL STARTER ASSY.

| <u>NO.</u> | <u>PART NO.</u> | <u>PART NAME</u>                          | <u>QTY.</u> | <u>REMARKS</u>           |
|------------|-----------------|---|-------------|--------------------------|
| 1          | 28400ZE3W01ZB   | STARTER ASSY., RECOIL *NH1* (BLACK) ..... | 1 .....     | INCLUDES ITEMS W/*       |
| 2*         | 28410ZE3W01ZB   | CASE, RECOIL STARTER *NH1* (BLACK)        | 1           |                          |
| 3*         | 28421ZE3W01     | PULLEY, RECOIL STARTER                    | 1           |                          |
| 4*         | 28422ZE2W01     | RATCHET, STARTER                          | 2           |                          |
| 5*         | 28441ZE2W01     | SPRING, FRICTION                          | 1           |                          |
| 6*         | 28442ZE2W01     | SPRING, STARTER RETURN                    | 1           |                          |
| 7*         | 28443ZE2W01     | SPRING, RATCHET                           | 2           |                          |
| 8*         | 28444ZE2W01     | RETAINER, SPRING                          | 1           |                          |
| 9*         | 28445ZE2W01     | HOLDER, SPRING                            | 1           |                          |
| 10*        | 28461ZE2W02     | GRIP, STARTER                             | 1           |                          |
| 11*        | 08560ZG92111    | ROPE, RECOIL STARTER .....                | 1 .....     | REPLACES P/N 28462ZE3W01 |
| 13*        | 90004ZE2W01     | SCREW, CENTER                             | 1           |                          |
| 14         | 90008ZE2003     | BOLT, FLANGE (6X10)                       | 3           |                          |

# HONDA GX340K1EDE2 ENGINE — SOLENOID ASSY.

SOLENOID ASSY.

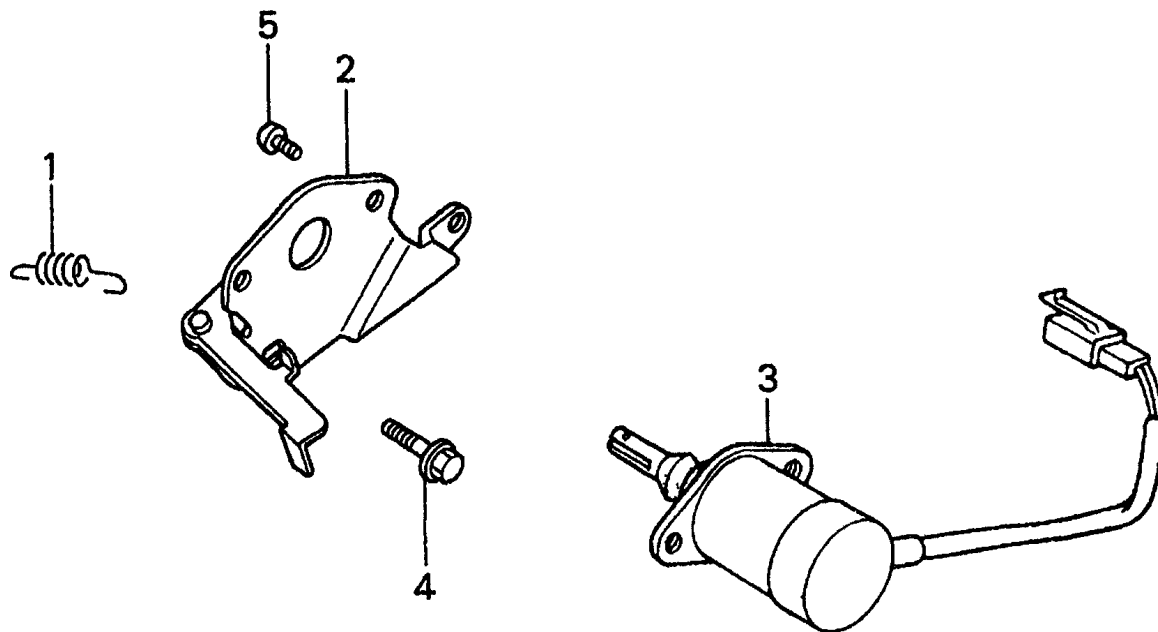

## HONDA GX340K1EDE2 ENGINE — SOLENOID ASSY.

### SOLENOID ASSY.

| <u>NO.</u> | <u>PART NO.</u> | <u>PART NAME</u>            | <u>QTY.</u> | <u>REMARKS</u> |
|------------|-----------------|-----------------------------|-------------|----------------|
| 1          | 16268893000     | SPRING, CHOKE RETURN        | 1           |                |
| 2          | 17850ZD1E30     | LEVER, THROTTLE             | 1           |                |
| 3          | 36160ZB4003     | SOLENOID ASSY.              | 1           |                |
| 4          | 90013883000     | BOLT, FLANGE (6X12) (CT200) | 1           |                |
| 5          | 93500050080A    | SCREW, PAN (5X8)            | 2           |                |

# HONDA GX340K1EDE2 ENGINE — LABELS ASSY.

LABELS ASSY.

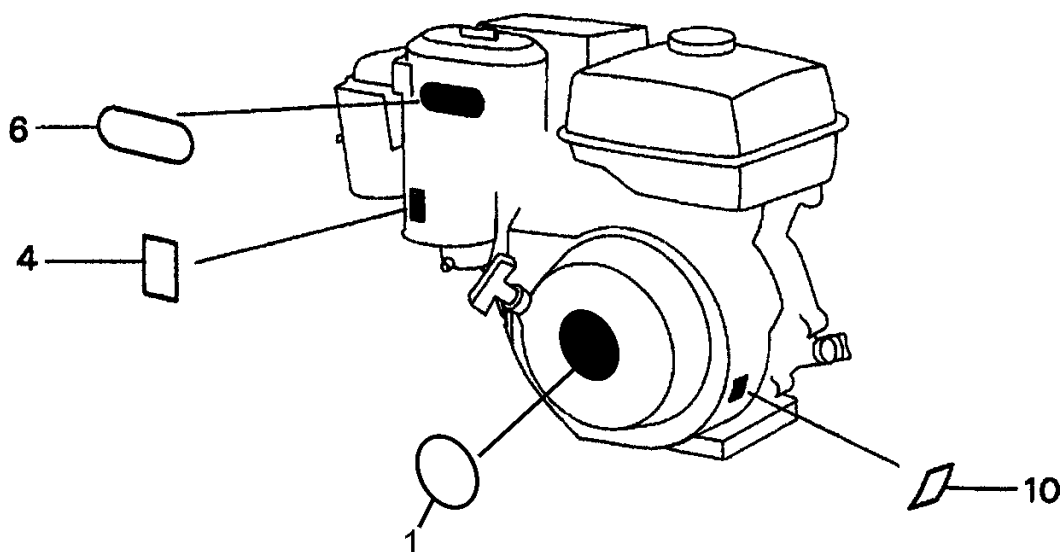



# HONDA GX340K1EDE2 ENGINE — LABELS ASSY.

## LABELS ASSY.

| <u>NO.</u> | <u>PART NO.</u> | <u>PART NAME</u>  | <u>QTY.</u> | <u>REMARKS</u> |
|------------|-----------------|-------------------|-------------|----------------|
| 1          | 87521ZE3W01     | EMBLEM            | 1           |                |
| 4          | 87528898620     | MARK, CHOKE       | 1           |                |
| 6          | 87533ZC0630     | MARK, AIR CLEANER | 1           |                |
| 10         | 87594ZB4A00     | MARK, OIL CAUTION | 1           |                |

**PAYMENT TERMS**

Terms of payment for parts are net 10 days.

**FREIGHT POLICY**

All parts orders will be shipped collect or prepaid with the charges added to the invoice. All shipments are F.O.B. point of origin. Multiquip's responsibility ceases when a signed manifest has been obtained from the carrier, and any claim for shortage or damage must be settled between the consignee and the carrier.

**MINIMUM ORDER**

The minimum charge for orders from Multiquip is \$15.00 net. Customers will be asked for instructions regarding handling of orders not meeting this requirement.

**RETURNED GOODS POLICY**

Return shipments will be accepted and credit will be allowed, subject to the following provisions:

1. A Returned Material Authorization must be approved by Multiquip prior to shipment.
2. To obtain a Return Material Authorization, a list must be provided to Multiquip Parts Sales that defines item numbers, quantities, and descriptions of the items to be returned.
  - a. The parts numbers and descriptions must match the current parts price list.
  - b. The list must be typed or computer generated.
  - c. The list must state the reason(s) for the return.
  - d. The list must reference the sales order(s) or invoice(s) under which the items were originally purchased.
  - e. The list must include the name and phone number of the person requesting the RMA.
3. A copy of the Return Material Authorization must accompany the return shipment.
4. Freight is at the sender's expense. All parts must be returned freight prepaid to Multiquip's designated receiving point.

5. Parts must be in new and resalable condition, in the original Multiquip package (if any), and with Multiquip part numbers clearly marked.
6. The following items are not returnable:
  - a. Obsolete parts. (If an item is in the price book and shows as being replaced by another item, it is obsolete.)
  - b. Any parts with a limited shelf life (such as gaskets, seals, "O" rings, and other rubber parts) that were purchased more than six months prior to the return date.
  - c. Any line item with an extended dealer net price of less than \$5.00.
  - d. Special order items.
  - e. Electrical components.
  - f. Paint, chemicals, and lubricants.
  - g. Decals and paper products.
  - h. Items purchased in kits.
7. The sender will be notified of any material received that is not acceptable.
8. Such material will be held for five working days from notification, pending instructions. If a reply is not received within five days, the material will be returned to the sender at his expense.
9. Credit on returned parts will be issued at dealer net price at time of the original purchase, less a 15% restocking charge.
10. In cases where an item is accepted, for which the original purchase document can not be determined, the price will be based on the list price that was effective twelve months prior to the RMA date.
11. Credit issued will be applied to future purchases only.

**PRICING AND REBATES**

Prices are subject to change without prior notice. Price changes are effective on a specific date and all orders received on or after that date will be billed at the revised price. Rebates for price declines and added charges for price increases will not be made for stock on hand at the time of any price change.

Multiquip reserves the right to quote and sell direct to Government agencies, and to Original Equipment Manufacturer accounts who use our products as integral parts of their own products.

**SPECIAL EXPEDITING SERVICE**

A \$35.00 surcharge will be added to the invoice for special handling including bus shipments, insured parcel post or in cases where Multiquip must personally deliver the parts to the carrier.

**LIMITATIONS OF SELLER'S LIABILITY**

Multiquip shall not be liable hereunder for damages in excess of the purchase price of the item with respect to which damages are claimed, and in no event shall Multiquip be liable for loss of profit or good will or for any other special, consequential or incidental damages.

**LIMITATION OF WARRANTIES**

No warranties, express or implied, are made in connection with the sale of parts or trade accessories nor as to any engine not manufactured by Multiquip. Such warranties made in connection with the sale of new, complete units are made exclusively by a statement of warranty packaged with such units, and Multiquip neither assumes nor authorizes any person to assume for it any other obligation or liability whatever in connection with the sale of its products. Apart from such written statement of warranty, there are no warranties, express, implied or statutory, which extend beyond the description of the products on the face hereof.



# OPERATION AND PARTS MANUAL

## **HERE'S HOW TO GET HELP**

PLEASE HAVE THE MODEL AND SERIAL  
NUMBER *ON-HAND* WHEN CALLING

### **MULTIQUIP CORPORATE OFFICE**

18910 Wilmington Ave.

Carson, CA 90746

Email: [mq@multiquip.com](mailto:mq@multiquip.com)

Internet: [www.multiquip.com](http://www.multiquip.com)

800-421-1244

FAX: 310-537-3927

### **PARTS DEPARTMENT**

800-427-1244

310-537-3700

FAX: 800-672-7877

FAX: 310-637-3284

### **MAYCO PARTS**

800-306-2926

310-537-3700

FAX: 800-672-7877

FAX: 310-637-3284

### **SERVICE DEPARTMENT**

800-421-1244

310-537-3700

FAX: 310-537-4259

### **TECHNICAL ASSISTANCE**

800-478-1244

FAX: 310-631-5032

### **WARRANTY DEPARTMENT**

800-421-1244, EXT. 279

310-537-3700, EXT. 279

FAX: 310-537-1173

Your Local Dealer is:



### **MULTIQUIP INC.**

18910 WILMINGTON AVE.

CARSON, CALIFORNIA 90746

800-421-1244 • 310-537-3700

FAX: 310-537-3927

E-mail: [mq@multiquip.com](mailto:mq@multiquip.com)

Internet: [multiquip.com](http://multiquip.com)