

#1589 Sprinter II Single Stage Alloy Tripod  
 #1584 Sprinter II Single Stage Carbon Tripod  
 #1580 Sprinter II 2-Stage Alloy Tripod  
 #1576 Sprinter II 2-Stage Carbon Tripod

## SPRINTER II OPERATOR'S MANUAL



## FEATURES AND CONTROLS

### Two-stage tripod

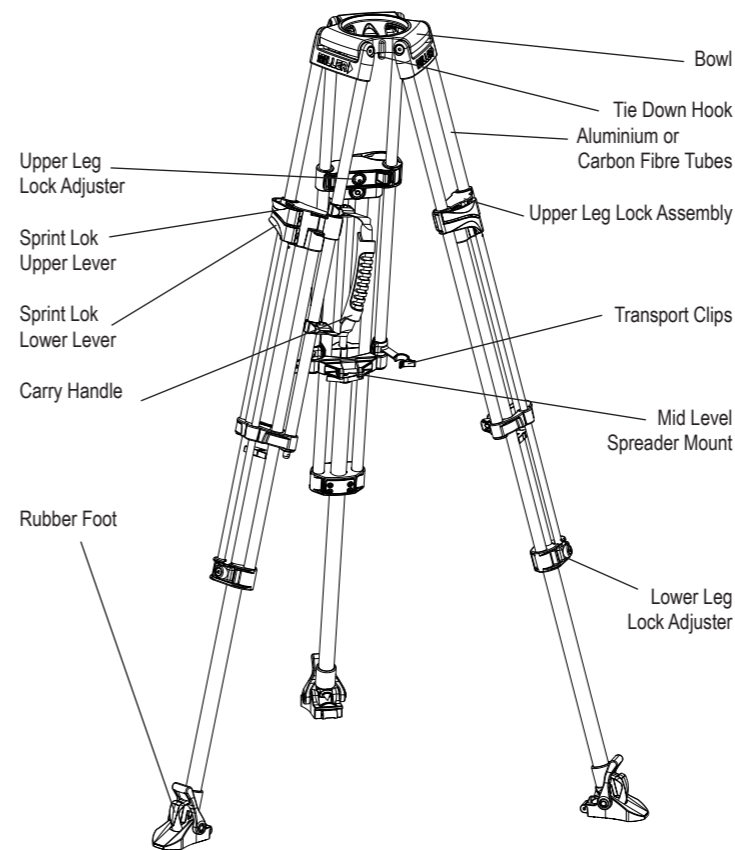

Fig 1.

### Single-stage tripod

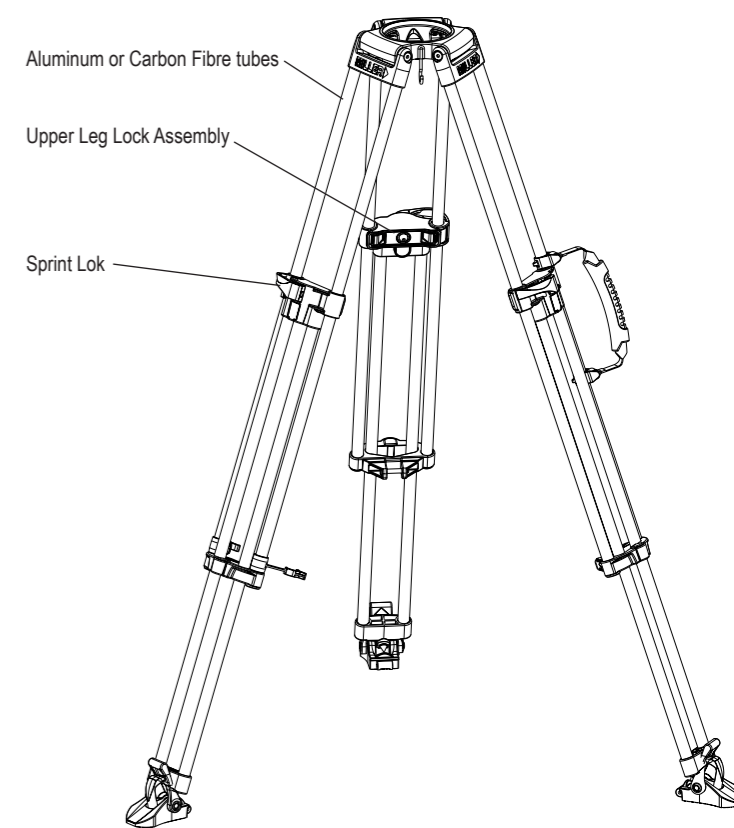

Fig 2.

## ACCESSORIES & COMPONENTS

Cat #	Description
#475	Detachable Rubber Feet (set of 3)
#990	Mid Level Spreader
#470	Ground Spreader
P5380	Carry Handle Assembly
P6434	Upper Leg Lock Lever
P6436	Lower Leg Lock Lever
P5330	Transport Clip
P6579	5mm Hex Key

## SERVICE, SALES & SUPPORT

Miller Authorised Service Agents must carry out all service and repair work on Sprinter tripods. Failure to observe this requirement may void warranty. It is advisable to notify Miller or a Miller Authorised Service Agent if a change of performance is observed as a result of dropping or rough usage. For information regarding sales and service of Miller products, or for your nearest Miller representative, please contact us via our website or at the following:

**MILLER CAMERA SUPPORT EQUIPMENT**  
 30 Hotham Parade, Artarmon, Sydney  
 NSW 2064 Australia  
 Tel: +61 2 9439 6377  
 Fax: +61 2 9438 2819  
 Email: sales@miller.com.au

**MILLER FLUID HEADS (Europe) LTD.**  
 Unit A2, Ford Lane Industrial Estate  
 Ford Lane, Ford  
 West Sussex, BN18 0DF United Kingdom  
 Tel: +44 (0)1243 555 255  
 Fax: +44 (0)1243 555 001  
 Email: sales@millertripods-europe.com

**MILLER CAMERA SUPPORT LLC (USA)**  
 218 Little Falls Road, Cedar Grove,  
 New Jersey 07009-1231 USA  
 Tel: (973) 857 8300  
 Fax: (973) 857 8188  
 Email: sales@millertripods.us

**MILLER TRIPODS Canada**  
 1055 Granville Street  
 Vancouver BC V6Z1L4, Canada  
 Tel: (604) 685 4654  
 Fax: (604) 685 5648  
 Email: sales@millercanada.com

## INTRODUCTION

Welcome to the Operating Manual for the Sprinter II camera support tripods from Miller. Sprinter II tripods feature Miller's revolutionary Sprint-Loks (Patented.) leg clamping system, and are designed to be used in conjunction with 100mm ball leveling fluid heads to support lightweight portable video cameras in a professional environment.

Sprinter II tripods are available as Single-Stage or 2-Stage extension tripods, supplied with your choice of high-strength, ultra-light carbon fiber or durable, anodised aluminum leg tubing.

Sprinter II are professional tripods designed for continuous use, and combine light weight and ease of set-up with rapid, stable and durable performance. They are constructed from the highest quality polymers and corrosion-resistant die cast and machined alloy components to offer high impact resistance and long-term durability under extreme location conditions and temperatures ranging from -40°C to +65°C.

The Sprinter II tripod range is available in a choice over 20 systems with Miller's Arrow and DS range of fluid heads and Mid Level or Ground Spreaders. These systems deliver the ultimate in rugged, rapid deployment camera support for ENG crews, freelance camera operators, as well as corporate and educational users.

## TECHNICAL DATA

Cat#	#1589	#1584	#1580	#1576
Tube Configuration	1 Stage	1 Stage	2 Stage	2 Stage
Tube Material	Alloy	Carbon Fibre	Alloy	Carbon Fibre
Maximum Load	45kg	45kg	45kg	45kg
Weight	3.0kg	2.5kg	3.5kg	2.9kg
Maximum Height- mm (in)				
Mid Level Spreader	1435 (56.5)	1435 (56.5)	1530 (60.3)	1530 (60.3)
Ground Spreader	1430 (56.3)	1430 (56.3)	1565 (61.7)	1565 (61.7)
Minimum Height- mm (in)				
Mid Level Spreader	670 (26.5)	670 (26.5)	440 (17.5)	440 (17.5)
Ground Spreader	635 (25.0)	635 (25.0)	415 (16.5)	415 (16.5)
Transport Length- mm (in)	850 (33.50)	850 (33.50)	705 (27.8)	705 (27.8)

## WARRANTY

Please refer to warranty card for complete details

## WEBSITE [www.millertripods.com](http://www.millertripods.com)

## TRIPOD SET-UP

Remove tripod from carry case and stand on a level surface (if possible). Unclip the 2 transport clips located on the lower tube section of the tripod.

**Single Stage Sprinter II Tripod**  
(one Sprint-Lok per leg to control lower stage).

1. Holding top of tripod, use thumb and forefinger to open (disengage) the Sprint-Lok lever on each tripod leg.
2. Extend the tripod to the required height then close (engage) the Sprint-Lok levers. Ensure the feet are flat on the ground.
3. Spread the tripod legs fully apart and repeat (1) to ensure the tripod bowl is approximately level.
4. Adjust the Mid Level or Ground spreader if required (see Spreader section)
5. Gently pull two legs outwards, to make the tripod more stable.
6. Level the fluid head using the Bubble Level and ball leveling feature of the fluid head.

**2-Stage Sprinter II Tripod**  
(2 Sprint Loks per leg to control mid and lower stage).

1. The 2 Sprint Loks on each leg can be opened (disengaged) independently or simultaneously.
2. Proceed as per Single Stage tripod setup instructions.

Note: On 2-Stage tripods, optimum rigidity is achieved when mid and lower tripod stages are both extended equally to achieve the desired height.

## TRIPOD PULL DOWN

1. Remove camera payload from fluid head.
2. Close the tripod, ensuring first that the spreader telescopic arms are exactly the same length before fully closing the tripod legs.
3. Open (disengage) all Sprint Loks while holding the top of the tripod and with tripod feet on the ground, then fully lower the tripod to its shortest length.
4. Close (engage) all Sprint Loks.
5. Re-attach 2 transport clips.
6. Return tripod to carry case if finished shooting.

## TRANSPORT CLIPS

The 2 Transport Clips (Fig 3), are designed to hold the Sprinter tripod's three legs together during transport. Their spring-loaded design means they are easily gripped and detached for set up, and reattached.

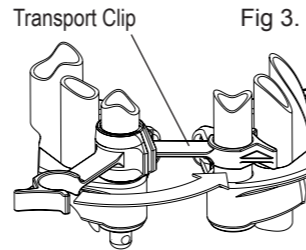

## CARRY HANDLE

The Sprinter II Inline patented Carry handle (fig 4.) is designed so the Sprinter II tripod and fluid head remain balanced while being carried by hand. The rubber handle offers secure grip, while the flexible nylon attachments let it rest, between the tripod legs, during shooting.

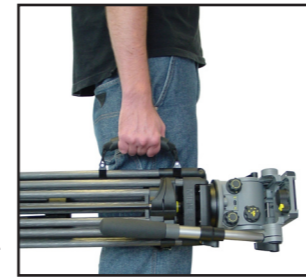

## SPREADERS

A Mid Level or Ground Spreader allows for rapid tripod setup and pull down by keeping tripod legs at an equal or preset distance relative to each other. A Mid Level Spreader attaches to the centre bracket of a tripod leg, while a ground spreader attaches directly to the tripod feet.

**Mid Level Spreader (Fig 5.)**

The Miller Mid Level Spreader provides for continuous variable adjustment between maximum and minimum height settings. The tripod height and overall footprint can be adjusted by turning the Height Adjustment knob or by adjusting the length of the telescopic spreader arms.

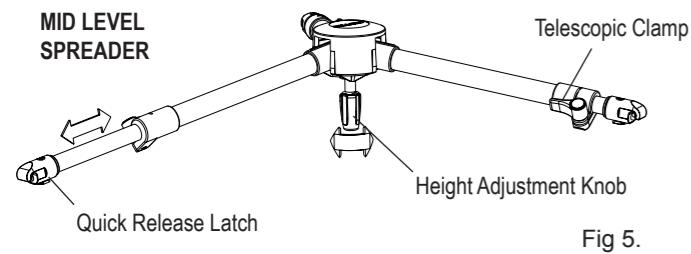

### Setup

1. Set the tripod feet to the desired location – you may need to screw the Height Adjustment Knob SCREW OUT or adjust the length of the spreader arms to do this.
2. Screw the Height Adjustment Knob SCREW IN until resistance is felt.
3. Pull two legs outwards slightly to ensure stable stance of tripod.

### Pull Down

1. Before closing the tripod, ensure all spreader arms are either fully retracted or adjusted to exactly the same length before closing the tripod legs. If a quick release latch is stuck, undo the spreader arm telescoping clamp to release tension on the latch.

**Ground Spreader (Fig 6.)**

The Miller Ground Spreader provides telescoping adjustment of each spreader arm to allow for lower height settings or uneven ground.

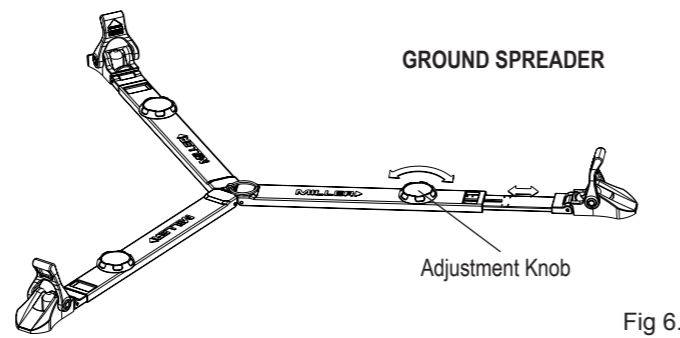

### Set up

1. Set the tripod in the desired location.
2. Pull two legs outwards until Ground Spreader is lying on the supporting surface
3. Extend telescoping arms if required to reposition individual tripod legs

### Pull Down

1. Close tripod by pulling Ground Spreader up by centre ring. Ensure all spreader telescoping arms are either fully retracted or adjusted to exactly the same length before closing the tripod legs.

## LEG LOCK ADJUSTMENT

Over time the leg locks may need adjusting to prevent leg slippage.

**Upper Leg Lock: ( Fig 7.)**

For Single & 2 stage Sprinter II Tripod.

Adjust the Upper Leg Lock Assembly in a locked position using (supplied) 5mm Hex Key - P6579.

1. Extend the upper stage half way and lock the Upper Lever.
2. Turn the Upper Leg lock Nut clockwise 1/8th of a turn. Release Upper Lever and ensure that stage slides freely.
3. When adjusted correctly Leg Lock Lever should only have a small amount of "free play" before locking action commences. If this free play is excessive repeat the steps above.

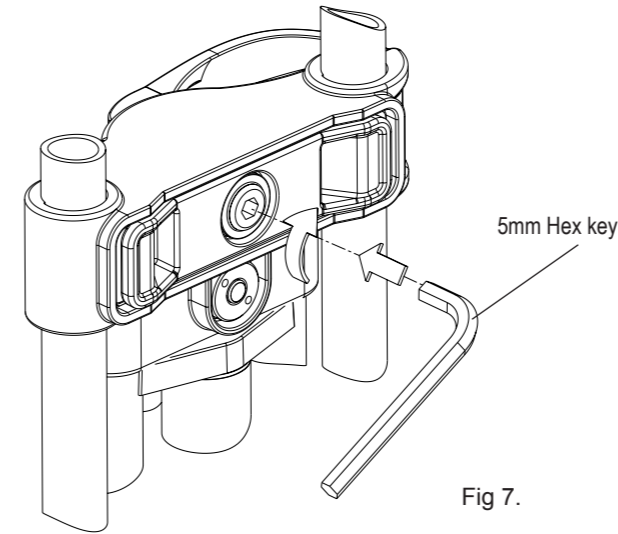

**Lower Leg Lock: (Fig 8.)**

For 2 stage Sprinter II Tripod only.

Adjust the Lower Leg Lock Assembly in locked position using a (supplied) 5mm Hex Key. - P6579

1. Extend the lower stage half way and lock the Lower Lever.
2. Tighten the adjusting screw gradually clockwise 1/8th of a turn. Release Lower Lever and ensure leg slides freely.
3. When adjusted correctly Leg Lock Lever should only have a small amount of "free play" before locking action commences. If this free play is excessive repeat the steps above.

When finished, ensure that all Leg Lock Levers lock flush with the tripod brackets.

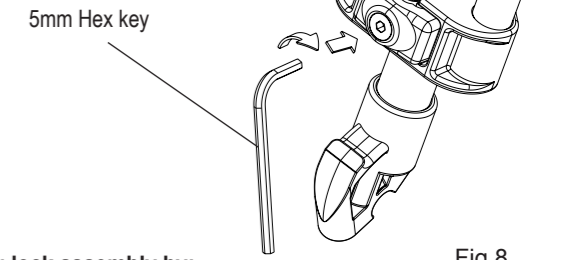

**Test each leg lock assembly by:**

- Unlocking and locking lever several times.
- The lever should close with a definitive 'click'.
- The end of the lever should close against the bracket.
- The tripod legs must slide freely when unlocked.

## LEG TO BOWL ADJUSTMENT

The leg to bowl pivot joint on the Sprinter tripod should have no lateral or free play movement and should swing with a firm, smooth resistance. Adjustment is usually not required; however, should it become necessary, the following procedure must be observed. (Fig 9.)

1. Leg to Bowl Adjustment to eliminate lateral or free play movement: Using a cross head screwdriver, ensure Bracket Mounting Screws on both sides of the Leg Top Bracket are tight. Retighten if necessary. Check all legs.
2. Leg pivot or 'swing' adjustment to ensure firm, smooth resistance. Tighten the Leg Pivot Screws on each side of the Leg Top Bracket using a 4mm Hex key until a smooth resistance is maintained. Check all legs.

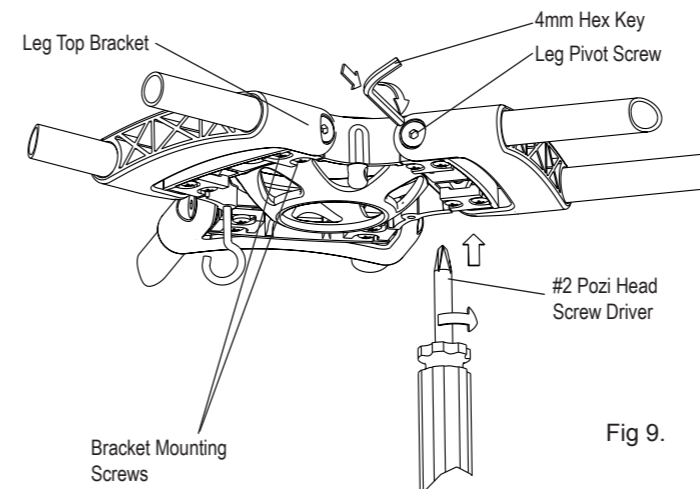

## SAFETY

**READ THE OPERATOR'S MANUAL**

Miller recommends that all camera support equipment should be carried in a reinforced carry case

All Miller Sprinter II systems include a reinforced carry case that protects the tripod from impact damage and limits exposure to heat and moisture during carriage and storage.

Ensure the weight of the payload does not exceed the specified capacity.

Never set up or pull down a tripod while a camera is mounted on it.

Ensure all Tripod/Spreader locks are securely engaged prior to mounting camera.

The safe operation of the tripod is the responsibility of the operator.

## MAINTENANCE

Regularly inspect the tripod, paying particular attention to any tube damage, leg lock adjustment, leg top adjustment, condition of the bowl rim, spreader mounting points, carry handle and feet.

Keep grit and dirt out of Sprint Loks as much as possible, including behind levers. Regularly clean the tripod with a clean damp rag or soft brush. Wipe off all sand, dust and salt spray.

Do not clean with solvents, cleaning fluids, lubricants, polishes, abrasives or wire brushes.

Transport and store the tripod in Miller case wherever possible. Store the tripod in a dry place, away from direct sunlight