

UB-4/2/8 Oven/Proofer with Deck Oven



Project _____

Item _____

Quantity _____

SIZE:

UB-4/2/8 - 85" High, 32-1/4" Wide, 36" Deep
2159 mm High, 819 mm Wide, 914 mm Deep

NU-VU's UB-4/2/8 oven/proofer with deck oven features our patented **V-AIR®** System in the oven. The heat is distributed evenly throughout the oven cavity by the fan located in the top of the oven which blows the air down the inside walls of the cavity and up and out through the holes at each shelf. This gives your product an even bake, top to bottom, side to side and front to back without ever turning pans.

The proofer portion of the UB-4/2/8 comes standard with a manual fill humidity system. The deck compartment of the UB-4/2/8 comes with two hearth stone decks included and separate temperature controls.

The UB-4/2/8 has a capacity of 4 full size pans in the oven and 8 full size pans in the proofer and 2 hearth stone decks for the deck oven.

These units also feature flush mount doors, which means no sagging or leaking. Lift off hinges allow for easy cleaning. The lighted oven and proofer compartments make it easy for you to do sight baking and proofing without having to open the doors, disturbing the internal temperatures.

CONSTRUCTION:

- Welded stainless steel
- Fully insulated
- Control panel accessible through front and side of unit
- Heating elements accessible inside of cabinet and through top or side

CONTROLS:

- Solid state controls
- Indicator lights for thermostats
- Microswitch fan motor cut-off
- Separate heat and humidity controls for proofer

LABORATORY CERTIFICATION AND APPROVAL



STANDARD FEATURES:

- **V-AIR®** technology
- Stainless steel construction
- Stainless steel hinges
- Flush mount lift off, no sag doors
- Tempered glass door on top oven and proofer
- Solid door on deck oven
- Silicone rubber gasket on top oven and proofer doors
- Three separate temperature controls for deck oven
- Two hearth stone decks included
- Heavy duty casters
- Overflow drain and pan
- Manual fill proofer

OPTIONAL FEATURES:

- Internal steam
- AutoMist humidity in proofer
- Warmer in proofer
- Cook'n Hold
- Solid door on oven or proofer
- Multi speed fan switch
- Product probe

NU-VU® UB-4/2/8 Oven/Proofer with Deck Oven



NU-VU® Food Service Systems

www.nu-vu.com
5600 13th Street
Menominee, MI 49858

1-800-338-9886 Toll Free
1-906-863-4401 Phone
1-906-863-5889 Fax

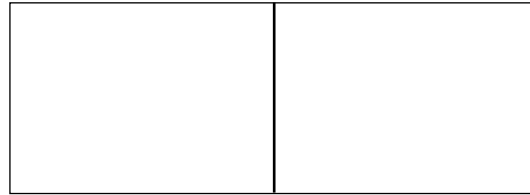

Approval / Stamp

UB-4/2/8 Oven/Proofer with Deck Oven

NU-VU® UB-4/2/8 Oven/Proofer with Deck Oven

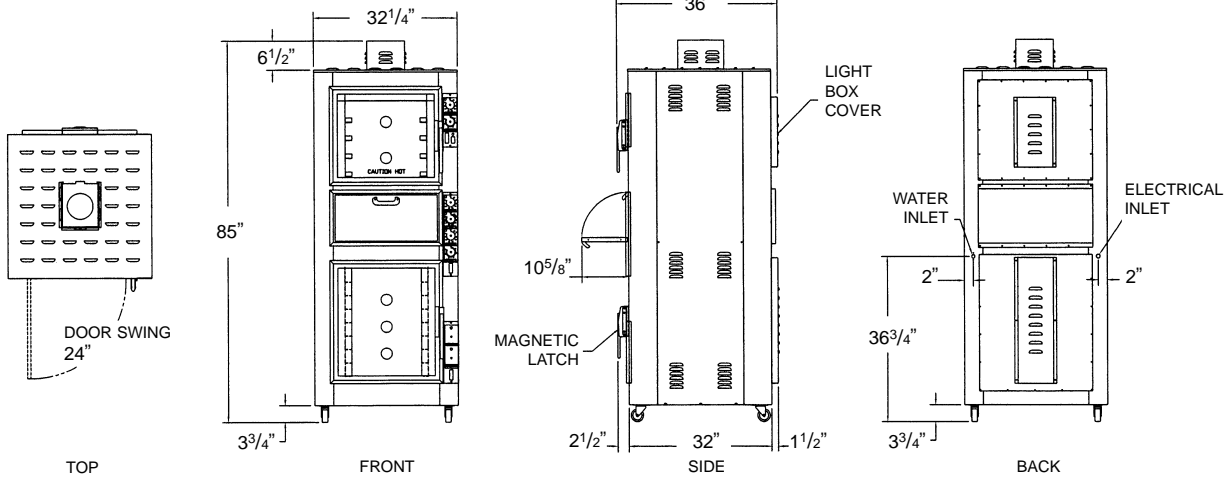

SPECIFICATIONS:

ELECTRICAL:

208 or 240 Volt single or three phase is standard. (Specify at time of order.)

SERVICE CONNECTIONS:

UB-4/2/8 is shipped from factory to be hard wired on site. Single phase uses three-wire system. Three phase uses four-wire system.

ELECTRICAL:

Amp Draw	208/1	208/3	240/1	240/3
	65	39	56	34

WATER:

A 1/4" waterline is required if a steam or AutoMist option is selected. A water filtration system should be used to minimize mineral build-up.

LISTINGS:

The UB-4/2/8 has NSF listings.



INSTALLATION:

Allow four inches on each side and back of unit for ventilation of oven.

CAPACITY: Per Compartment

	18"x26" Sheet Pans	13"x18" Sheet Pans	Spacing
Oven	4	8	4"
Proofer	8	16	3"
Deck	2	4	3-1/4"

DIMENSIONS:

	Height	Width	Depth
Exterior	85"	32-1/4"	36"
Interior			
Oven	18-1/4"	18-1/4"	28-1/2"
Proofer	26-1/2"	18-1/2"	28-1/2"
Deck	12-5/8"	23-1/2"	27-1/2"

DOOR SWING: Oven - 24" (616 mm)
Proofer - 24" (616 mm)

PACKING SIZE:

86" High, 36" Wide, 38" Deep
(2184 mm High, 914 mm Wide, 965 mm Deep)

SHIPPING WEIGHT:

650 Pounds (295 Kg), FOB Menominee, MI 49858