

## Klipsch Icon Series

### Owner's Manual

## Important Safety Information

1. READ these instructions.
2. KEEP these instructions.
3. HEED all warnings.
4. FOLLOW all instructions.
5. DO NOT use this apparatus near water.
6. CLEAN ONLY with dry cloth.
7. DO NOT block any ventilation openings. Install in accordance with the manufacturer's instructions.
8. DO NOT install near any heat sources such as radiators, heat registers, stoves, or other apparatus (including amplifiers) that produce heat.
9. ONLY USE attachments/accessories specified by the manufacturer.
10. USE only with a cart, stand, tripod, bracket, or table specified by the manufacturer, or sold with the apparatus. When a cart is used, use caution when moving the cart/apparatus combination to avoid injury from tip-over. 
11. DO NOT expose this apparatus to dripping or splashing and ensure that no objects filled with liquids, such as vases, are placed on the apparatus.

REFER all servicing to qualified service personnel.





The exclamation point, within an equilateral triangle, is intended to alert the user to the presence of important operating and maintenance (servicing) instructions in the literature accompanying the product.



The lightning flash with arrowhead symbol within an equilateral triangle, is intended to alert the user to the presence of uninsulated "dangerous voltage" within the product's enclosure that may be of sufficient magnitude to constitute a risk of electrical shock to persons.

**WARNING:** To reduce the risk of fire or electrical shock, do not expose this apparatus to rain or moisture.

**WARNING:** No naked flame sources – such as candles – should be placed on the product.

	<b>WARNING</b> RISK OF ELECTRIC SHOCK. DO NOT OPEN.	
<b>WARNING:</b> Do Not Open! Risk of Electrical Shock. Voltages in this equipment are hazardous to life. No user-serviceable parts inside. Refer all servicing to qualified service personnel.		

## Klipsch Icon Series Loudspeaker

Thank you for your purchase of this Klipsch Icon Series Loudspeaker. In total, there are five wood finish models within the Klipsch Icon Series: the WF-35 and WF-34 floorstanding speakers, the WB-14 bookshelf speaker, the WC-24 center channel speaker and the WS-24 surround channel speaker.

All of these speakers utilize a new wide dispersion Tractrix® Horn-loaded tweeter with XT™ technology. This proprietary design radiates sound in a smooth, enveloping 80-degree by 80-degree pattern. As with all Klipsch horn-loaded technology, this version also produces more output using less energy and delivers the company's signature dynamic sound.

Please be sure to register online at [www.klipsch.com](http://www.klipsch.com) so we are better able to serve you.

## Inspection

Please check promptly for any transit damage. Carefully unpack your new speaker system and verify the components against the packing list. In extreme circumstances, items may have become damaged in transit. If any damage is discovered, notify the delivery service and dealer where the system was purchased. Make a request for inspection, and follow their instructions for evaluation. Be sure to keep the product's original shipping carton.

## Bookshelf and Center

These models are supplied with self-stick rubber feet to prevent surface damage. (See Figure 1 for proper application.)

## Room Placement

Your Klipsch Icon loudspeakers will perform well in a variety of locations, but best results will be achieved using the following guidelines:

### Front Left and Right Speakers (See Figures 2A and 2B.)

- Place on a common wall 6 to 15 feet apart.
- If used in a home theater system, position the speakers flanking your video display.
- Position them equal distance from the front wall (if they are not wall-mounted).
- Position them at the same height above the floor (for non-floor standing models) with the high frequency drivers at seated ear height.
- Angle speakers toward the listener and even with or forward of any adjacent obstructions (if they are not wall-mounted).
- Placing them near a corner or wall provides the greatest amount of bass while moving the speakers away from room boundaries reduces bass energy.
- Asymmetrical placement of a pair of speakers from adjacent side walls can smooth room-induced bass unevenness.
- Bookshelf models may be placed on shelves, optional floor stands or on walls using appropriate brackets.
- Experiment with the above guidelines to suit your taste and to compensate for your room's acoustic characteristics.

### Center Channel Speaker (See Figures 2A and 2B.)

- Place immediately above or below the center of your video display.

### Surround Channel Speakers (See Figures 2A, 2B and 3.)

- Place above seated ear height on side or rear walls (approximately 4-5 feet above the floor).
- Use the attached wall brackets to hook to appropriately sized screw heads screwed into a wall stud and wall anchor or two wall anchors with a suitable weight bearing capacity. (See Figure 3.)

### On Wall Placement

- Klipsch Icon bookshelf models may be wall-mounted using the  $\frac{1}{4}$ -20 threaded insert on the rear of the speaker. Be sure the mounting hardware you are using has the necessary load bearing capabilities before hanging any speaker. If you use a bracket, see the bracket owner's manual for mounting details.



Never use the wall bracket for mounting the speaker to the ceiling.

### Connecting



Turn your amplifier off before making any connections.

- Your loudspeakers are equipped with positive (Red) and negative (Black) connection terminals on the rear of the cabinet. These correspond to the positive and negative terminals on the appropriate channel (left, right, center, rear etc.) of your amplifier.

### Standard Connections (See Figure 4.)(All Models)

- All speakers in your system must be connected in phase with the positive speaker terminal connected to the positive amplifier terminal. Repeat this for the negative speaker terminal and amplifier terminals. Most speaker wire has distinguishing markings on the insulation of one of the conductors to assist in correct hookup.
- Use 16 gauge (AWG), two conductor, copper wire at a minimum and larger gauge wire for longer runs. The connection terminals on your loudspeaker will accommodate bare wire, spade terminals, and banana plugs.



With all connection types, take care that there is no contact between the positive and negative terminals at the speaker and amplifier. Damage to your equipment may result.

### WF-35 and WF-34 Standard Connections

- Use either pair of positive and negative terminals keeping the metal coupling straps in place.

### Bi-Wire Connections (See Figure 5.)

- The WF-35 and WF-34 are equipped with two pair of connection terminals for bi-wire hookup and enhanced performance.
- Remove the metal coupling straps.
- Connect one speaker wire (+ and -) to the top pair of binding posts and a second speaker wire (+ and -) to the bottom pair of binding posts.

### Bass Management

When using your speakers in a home theater system, consult the owner's manual of your surround electronics for proper application of bass management settings.

- As a general rule, compact speakers (Bookshelf, Center Channel and Surrounds) are set to the "Small," or bass-limited setting.
- Floorstanding speakers are typically set to the "Large," or full-range setting.
- Also refer to the electronics instructions for adjusting the relative volume levels of the speakers so they are at the same level when listened to from the primary listening position.

### Care and Cleaning

- Occasional dusting or wiping of the cabinet with a cloth is all that is required. Never use abrasive or solvent type cleaners or harsh detergents.
- A vacuum cleaner with a soft brush attachment may be used to clean the grille fabric.
- Never spray polishes or cleaners on the drive units (woofers, midranges or tweeters).

## **EU Compliance Information**

Eligible to bear the CE mark, Conforms to European Union Low Voltage Directive 73/23/EEC and 2006/95/EC; Conforms to European Union EMC Directives 89/336/EEC and 2004/108/EC.

## **WEEE Notice**

Note: This mark applies only to countries within the European Union (EU) and Norway.



This application is labeled in accordance with European Directive 2002/96/EC concerning waste electrical and electronic equipment (WEEE). This label indicates that this product should not be disposed of with household waste. It should be deposited at an appropriate facility to enable recovery and recycling.

## **Product Registration Benefits**

- Klipsch will keep you up-to-date on new products and promotions
- Your personal information will never be resold

Register your product online at [www.klipsch.com/register](http://www.klipsch.com/register)

# Figure 1

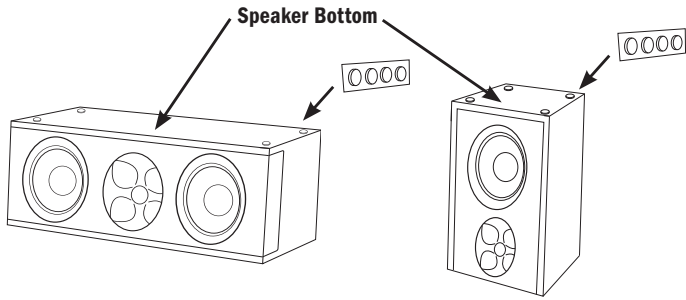

# Figure 2A - Traditional Front Speaker Placement

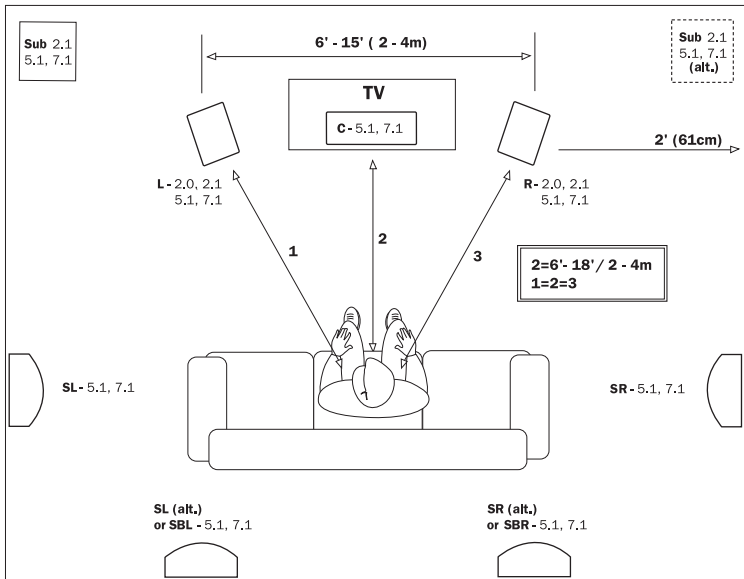

# Figure 2B - On-Wall Front Speaker Placement

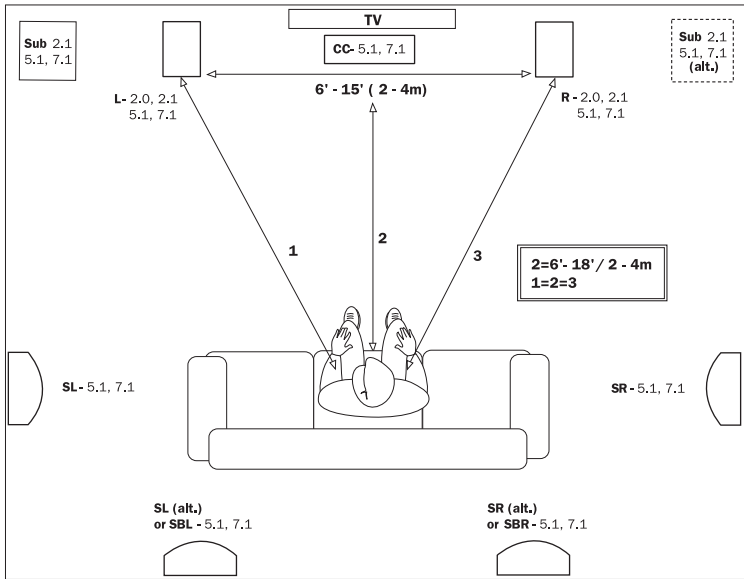

# Figure 3

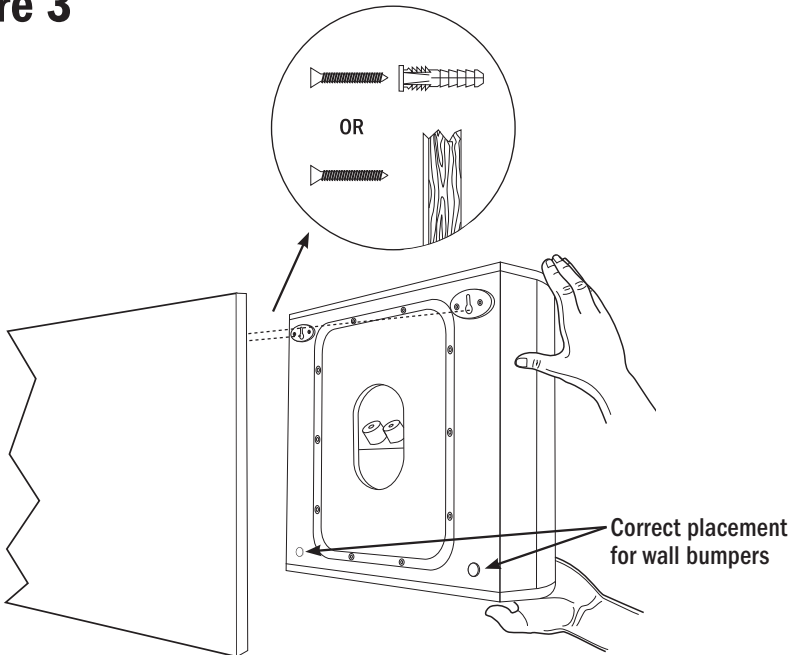

# Figure 4

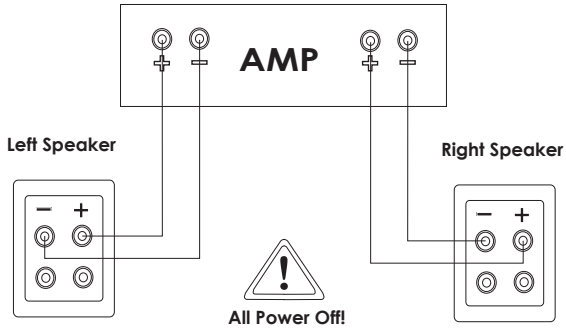

# Figure 5

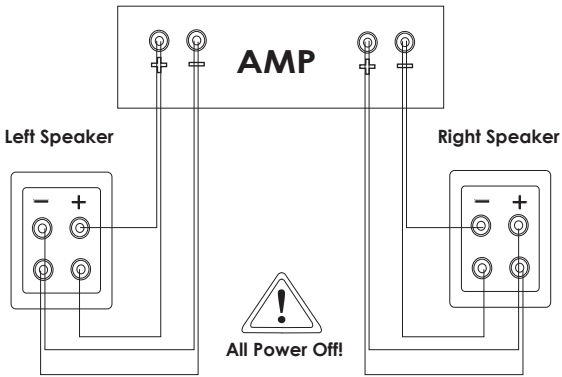



# Power.

# Detail.

# Emotion.

For over 60 years, we've made speakers for people who are as passionate about great sound as we are. That's why every Klipsch speaker is horn-loaded to create a remarkably accurate listening experience for your music and movies. From our smallest satellites to our acclaimed professional theater installations, our speakers deliver sound that's so lifelike, you have to feel it to believe it.

[www.klipsch.com](http://www.klipsch.com)