

GF 400 BV Sebago
Gas Stove

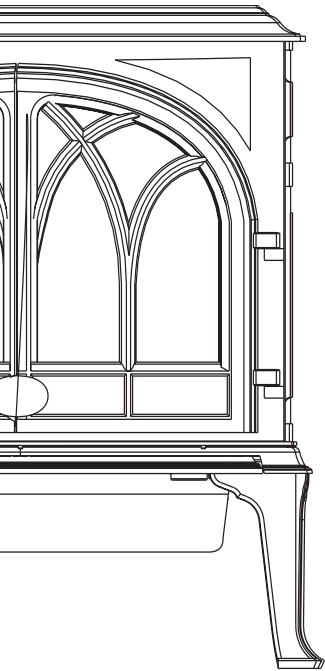

Installation and Operation Instructions



WARNING:
IF THE INFORMATION IN THESE INSTRUCTIONS ARE NOT FOLLOWED EXACTLY, A FIRE OR EXPLOSION MAY RESULT CAUSING PROPERTY DAMAGE, PERSONAL INJURY OR LOSS OF LIFE.

FOR YOUR SAFETY:
DO NOT STORE OR USE GASOLINE OR OTHER FLAMMABLE VAPORS AND LIQUIDS IN THE VICINITY OF THIS OR ANY OTHER APPLIANCE.

INSTALLATION:
INSTALLATION AND SERVICE MUST BE PERFORMED BY A QUALIFIED INSTALLER, SERVICE AGENCY OR LICENSED GAS SUPPLIER.

THIS PRODUCT MUST BE INSTALLED BY A LICENSED PLUMBER OR GAS-FITTER WHEN INSTALLED IN THE COMMONWEALTH OF MASSACHUSETTS.

A CARBON MONOXIDE (CO) DETECTOR SHALL BE INSTALLED IN THE SAME ROOM AS THE APPLIANCE.

WHAT TO DO IF YOU SMELL GAS:

- DO NOT TRY TO LIGHT ANY APPLIANCE.
- DO NOT TOUCH ANY ELECTRICAL SWITCHES.
- DO NOT USE THE PHONE IN YOUR BUILDING. IMMEDIATELY CALL YOUR GAS SUPPLIER FROM A NEIGHBOR'S PHONE.
- FOLLOW YOUR GAS SUPPLIER'S INSTRUCTIONS.
- IF YOU CANNOT REACH YOUR GAS SUPPLIER, CALL THE FIRE DEPARTMENT.

AVERTISSEMENT:
ASSUREZ-VOUS DE BIEN SUIVRE LES INSTRUCTIONS DANS CETTE NOTICE POUR REDUIRE AU MINIMUM LE RISQUE D'INCENDIE OU POUR EVITER TOUT DOMMAGE MATERIEL, TOUTE BLESSURE OU MORTALITE'.

NE PAS ENTREPOSER NI UTILISER D'ESSENCE NI OU LIQUIDES INFLAMMABLES DANS LE VOISINAGE DE CET APPAREIL OU DE TOUT AUTRE APPAREIL.

L'INSTALLATION LE SERVICE DOIVENT ETRE EXECUTES PAR UN INSTALLATEUR QUALIFIE, AGENCE DE SERVICE OU LE FOURNISSEUR DE GAZ.

QUE FAIRE SI VOUS SENTEZ UNE ODEUR DE GAZ.

- NE PAS TENTER D'ALLUMER L'APPAREIL
- NE TOUCHEZ A AUCUN INTERRUPTEUR.
- NE PAS VOUS SERVIR DES TELEPHONES SE TROUVANT DANS LE BATIMENT OU VOUS VOUS TROUVEZ.
- APPELEZ IMMEDIATEMENT VOTRE FOURNISSEUR DE GAZ CHEZ UN VOISIN. SUIVEZ LES INSTRUCTIONS DU FOURNISSEUR.
- SI VOUS NE POUVEZ REJOINDRE LE FOURNISSEUR DE GAZ, APPELEZ LE SERVICE DES INCENDIES.

Welcome to Jøtul...

Congratulations on the purchase of your new Jøtul GF 400 BV Sebago gas stove.

We at Jøtul are glad you've made the decision to warm your hearth with a Jøtul product. Your new stove exemplifies our experience gained over 150 years as the world's largest manufacturer of solid fuel burning appliances. We've been building fine quality cast iron stoves and fireplaces continuously since 1853.

The Jøtul GF 400 BV Sebago combines advanced gas technology with the warm, traditional elements of cast iron. With proper care and use, your stove will provide you with many years of safe, dependable and satisfying service.

Please take a few minutes to familiarize yourself with this manual and the features of your new Jøtul fireplace.

Table of Contents

Service Tools	4
Specifications	4
General Information	5
Safety Information	6
Installation Requirements	
Location	6
Hearth Protection	6
Clearances	7
Mantel & Trim	7
Alcove	7
Vent Requirements	10
Fuel Conversion	11
Gas Connection	13
Gas Pressure	14
Log Set Installation	15
Flame Adjustment	16
Wall Thermostat	16
Remote Control	16
Decorative Pipe	17
System Check	17
Operation	18
Maintenance	19
Glass Replacement	19
Optional Blower	20
Optional Antique Brick Kit	22
High Altitude Adjustment	23
Illustrated Parts Breakdown	24
Replacement Parts List	25
Lighting Instructions	Back Cover

THIS OWNER'S MANUAL PROVIDES INFORMATION TO ENSURE SAFE INSTALLATION AND EFFICIENT, DEPENDABLE OPERATION OF YOUR FIREPLACE INSERT. PLEASE READ THESE INSTRUCTIONS IN THEIR ENTIRETY AND MAKE THEM AVAILABLE TO ANYONE USING OR SERVICING THIS GAS INSERT.

THIS PRODUCT MUST BE INSTALLED BY A LICENSED PLUMBER OR GAS-FITTER WHEN INSTALLED IN THE COMMONWEALTH OF MASSACHUSETTS.

Jøtul GF 400 BV Sebago Gas Heater

Manufactured and Distributed by:
Jøtul A.S.A.
Fredrikstad, Norway
Jøtul North America
Gorham, Maine U.S.A.

M.E.A. 369-04-E

Test Standards

This appliance complies with National Safety standards and is tested and listed by Intertek Testing Services of



Middleton, Wisconsin to ANSI Z21.88-2002 • CSA 2.33-M02 and CAN/CGA 2.17--M91, CSA P.4-01.2 for Canada.

DO NOT ATTEMPT TO ALTER OR MODIFY THE CONSTRUCTION OF THE APPLIANCE OR ITS COMPONENTS. ANY MODIFICATION OR ALTERATION WILL VOID THE WARRANTY, CERTIFICATION AND LISTING OF THIS APPLIANCE.

**NATIONAL
FIREPLACE
INSTITUTE**



CERTIFIED

www.nficertified.org

We recommend that our gas hearth products be installed and serviced by professionals who are certified in the U.S. by the National Fireplace Institute® (NFI) as NFI Gas Specialists.



General Information

■ THIS HEATER MUST BE INSTALLED AND MAINTAINED BY A QUALIFIED SERVICE AGENCY.

■ The installation and repair of this appliance must be done by a qualified service person. Failure to properly install and maintain this heater could result in an unsafe or hazardous installation, which may result in a fire, explosion, property damage, personal injury or loss of life.

■ This appliance may be installed in an aftermarket permanently located, manufactured (mobile) home, where not prohibited by local codes.

This appliance is only for use with the type(s) of gas indicated on the rating plate. This appliance is not convertible for use with other gases, unless a certified kit is used.

Cet appareil peut être installé dans un maison préfabriquée (mobile) déjà installée à demeure si les règlements locaux le permettent.

Cet appareil doit être utilisé uniquement avec les types de gas indiqués sur la plaque signalétique. Ne pas l'utiliser avec d'autres gas sauf si un kit de conversion certifié est installé.

■ This appliance should be inspected before use and at least annually. More frequent cleaning may be required due to excessive lint from carpeting, bedding material, etc. It is imperative that control compartments, burners, and circulating air passages of the appliance be kept clean.

■ THIS APPLIANCE MUST NOT BE CONNECTED TO A CHIMNEY OR FLUE SERVING ANY OTHER APPLIANCE.

■ The installation must conform to local codes. Your local Jøtul dealer can assist you in determining what is required in your area for a safe and legal installation. Some areas require a permit to install a gas burning appliance. Always consult your local building inspector, or authority having jurisdiction, to determine what regulations apply in your area.

■ **CODE COMPLIANCE:** Your local officials have final authority in determining if a proposed installation is acceptable. Any requirement that is requested by the local authority having jurisdiction, that is not specifically addressed in this manual, defaults to local code. In the absence of local codes, the installation requirements must comply with the current edition of National codes. In the U.S., these requirements are established in the National Fuel Code, ANSI Z223.1.(NFPA 54) current edition. In Canada, the codes have been established in CAN/CGA B149 Fuel Installation Code, current edition.

Consult the local or national installation code(s) to assure that adequate combustion and ventilation air is available.

■ Installer l'appareil selon les codes ou règlements locaux, ou, en l'absence de tels règlements, selon les Codes d'installation CAN/CGA-B149.

■ **DO NOT OPERATE THIS STOVE IF ANY PART HAS BEEN UNDER WATER.** Call a qualified service technician to inspect the heater and to replace any part of the control system and any gas control which may have been under water.

■ Ne pas se servir de cet appareil s'il a été plongé dans l'eau, complètement ou en partie. Appeler un technicien qualifié pour inspecter l'appareil et remplacer toute partie du système de contrôle et toute commande qui ont été plongés dans l'eau.

Glass Panel

Do not operate this appliance with the glass front removed, cracked, or broken. Replacement of the glass should be done by a licensed or qualified service person. Only remove glass for routine service. Always handle glass carefully.

Unpacking your stove

1. Remove the Top Plate of the stove by simply lifting it straight off of the stove body.
2. To open the firebox, disengage the two Glass Frame Latches located on top of the firebox. Pull each handle forward to clear the latch from the notch in the frame.

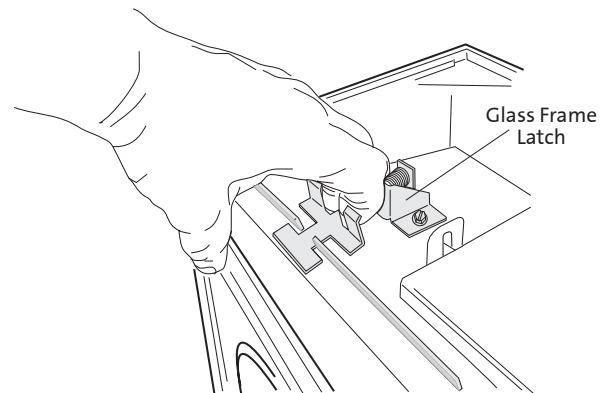

3. Familiarize yourself with the installation requirements specified in this manual, before beginning the installation.

Hardware Bag Contents

- Fuel Conversion Kit - LP 156005
- Decorative Pipe Mounting Brackets (4) .. 129469

Safety Information

During normal operation, the GF 400 BV gas stove will reach high surface temperatures. Therefore:

- Due to the high operating temperatures, this appliance should be located out of traffic areas and away from furniture and draperies.
- Children and adults should be alerted to the hazards of high surface temperatures and should stay away to avoid burns and/or clothing ignition.
- Young children should be supervised while they are in the same room as the GF 400 BV gas stove.
- Clothing or other flammable materials should not be placed ON or NEAR the GF 400 BV gas stove. Surveiller les enfants. Garder les vêtements, les meubles, l'essence ou autres liquides à vapeur inflammables loin de l'appareil.
- NEVER store or use gasoline or any other flammable vapors or liquids in the vicinity of the GF 400 BV gas stove.
- Never burn any other materials in your GF 400 BV Sebago gas stove, it is strictly designed for use with natural gas or propane fuel ONLY.
- Any safety screen, glass or guard removed for servicing the appliance must be replaced prior to operating the appliance.

Location

In selecting a location for the stove, consider the following points:

- 1) Heat distribution
- 2) Vent termination requirements
- 3) Gas supply line routing
- 4) Traffic areas, furniture, draperies, etc.

The GF 400 BV may be located on or near conventional construction materials, however, proper clearance to combustibles must be maintained in order to provide adequate air circulation around the appliance. Also, it is important to provide adequate access around the stove for servicing and proper operation.

The clearance and hearth specifications listed in this manual are the minimum requirements for combustible material. A combustible material is anything that can burn (i.e. sheet rock, wall paper, wood, fabrics etc.). These surfaces are not limited to those that are visible and also include materials that may be located behind non-combustibles.

If you are not sure of the combustible nature of a material, consult your local fire officials. "Fire Resistant" materials are considered combustible: they are difficult to ignite, but will burn. Also, "fire-rated" sheet rock is considered combustible.

Hearth Requirements

The GF 400 BV gas stove CANNOT be installed directly on carpeting, vinyl, linoleum or Pergo®.

If this appliance will be installed on any combustible material OTHER THAN WOOD, a floor pad must be installed that is either metal or wood, or a listed hearth pad. This floor protection must extend the full width and depth of the appliance. It is not necessary to remove carpeting, vinyl or linoleum from underneath the floor protection. See fig. 1.

Figure 1. Minimum Hearth Protection.

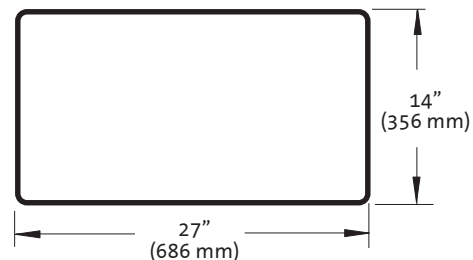

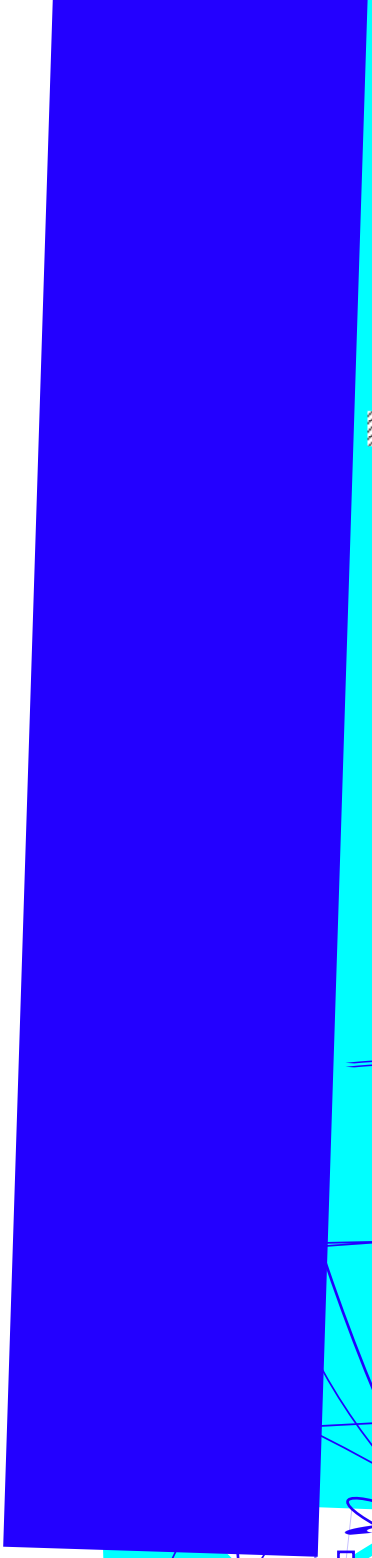

3 "

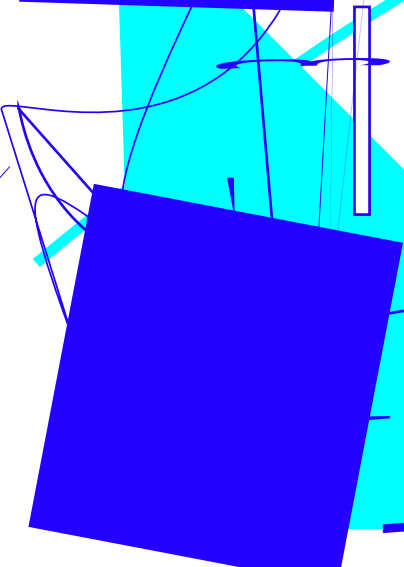

v

Figure

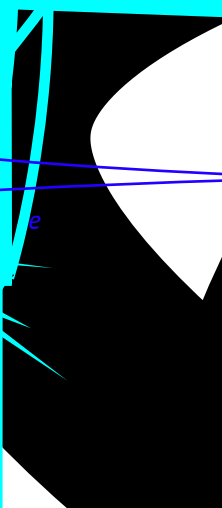
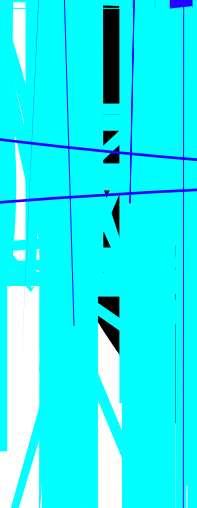
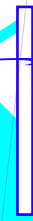

e

Vent Requirements

The GF 400 BV Sebago is specifically designed to operate using 4" Type B vent pipe components or a Listed Flexible gas liner.

- All venting components must be installed in accordance with the terms of their listing and manufacturer's instructions.
- The minimum height of a vertically terminated system shall be no less than **7'**, and the maximum height shall be no more than **35'**. See diagrams page 9.
- With steep roofs, nearby trees, and in predominant windy conditions, poor draft or down draft conditions can occur. In these cases, increasing the height of the vent or high wind termination caps may improve the situation.
- **ELBOWS:** If an offset or elbow is necessary in the vertical rise, it is important to support the vent pipe every three feet, to avoid excessive stress on the offsets.
- Whenever possible use 45° elbows opposed to 90° elbows. This offers less restrictions for the flow of flue gases.

Maximum number of 90° elbows: three

Maximum number of 45° elbows: four

- **TOTAL MAXIMUM HORIZONTAL RUN ANYWHERE IN THE VENTING CONFIGURATION IS 4 FEET.** The distance between any 45° elbows is considered a horizontal run. See diagrams, page 10.
- Any Type B vent passing through a roof must have a flashing, storm collar, thimble and a Type B cap is required. See diagrams, page 10.
- Venting on the Sebago CANNOT be less than 4" in diameter or greater than 4" in diameter.
- Any **unused** flue or masonry enclosure can be used as a passage way for venting, but the flue must be relined using Type B 4" vent or Listed Flexible Gas Liner.
- The remaining space around the liner in a masonry or zero-clearance flue CANNOT be used to vent any other appliance.

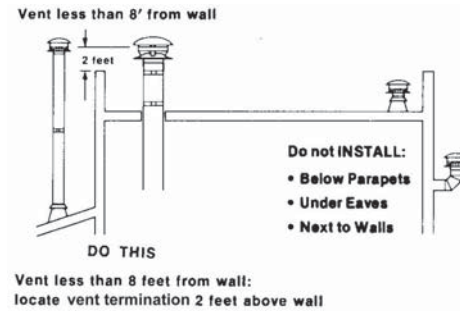
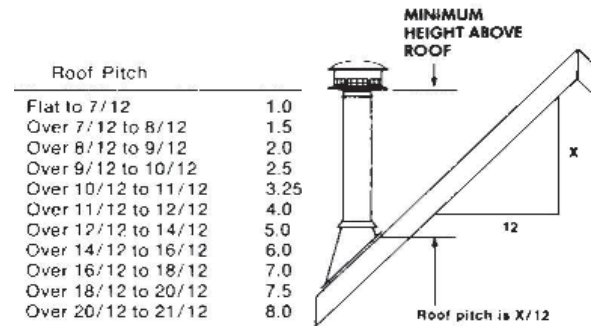

Figure 5. Termination Height Requirements.

- When terminating through the roof refer to the Gas Vent Rule for proper vent termination height. See fig. 5.
- NO venting may terminate horizontally or below roof eaves.
- Passage through combustibles (walls, ceilings) must be with Type B venting and must maintain listed clearances. **The GF 400 BV Sebago stove is approved for use only with 4" Simpson Dura-Vent Wall Thimble #3143 to maintain proper vent clearances.**
- Any horizontal run should have an upward slope of 1/4" per foot toward the termination cap.
- When venting through a thimble into a masonry flue, any venting exposed in the room must be Type B venting, or a flexible liner sleeve within 24 ga. 6" stove pipe.
- Listed Flexible Gas Liners may not be exposed in any living space.

- When 6" diameter decorative pipe is installed to cover the venting any Listed Flexible Gas liner must be connected directly to the stove's draft hood.
- Use of single wall connector pipe as a vent is prohibited for use with the GF400 Sebago B-Vent stove.
- A firestop is required at every floor.
- Any venting that is exposed above the first floor, regardless of attic space or living space, must be enclosed. Always maintain the required clearance from all sides of the vertical vent system according to manufacture.
- Installation of any components not manufactured or approved by Jøtul or failure to meet all clearance requirements will void all warranties and could result in property damage, bodily injury, or serious fire.
- Never modify any venting component, or use any damaged venting product.
- THE GAS APPLIANCE AND VENT SYSTEM MUST BE VENTED DIRECTLY TO THE OUTSIDE OF THE BUILDING, AND NEVER ATTACHED TO A CHIMNEY SERVING A SOLID FUEL OR GAS BURNING APPLIANCES.
- BE SURE TO MAINTAIN THE PROPER CLEARANCES TO COMBUSTIBLES AS DEFINED IN THIS MANUAL AND IN THE INSTRUCTIONS PROVIDED WITH EACH VENTING COMPONENT.
- **When installing at an altitude above 2000' the minimum vertical rise becomes 12' from the draft hood.**

NOTE:

A chimney system located outside the building envelope may be subject to downdrafting and/or flow reversal. Atmospherically-vented appliances, such as B-Vents, may not be compatible with these chimney systems.

All atmospherically-vented appliances (B-Vents) are affected by atmospheric conditions and house pressurization. For example, a B-Vent appliance vented to an outside chimney system in a basement will likely be subject to negative pressure. This type of installation is not recommended.

Venting through a Masonry or Prefabricated Manufactured Chimney

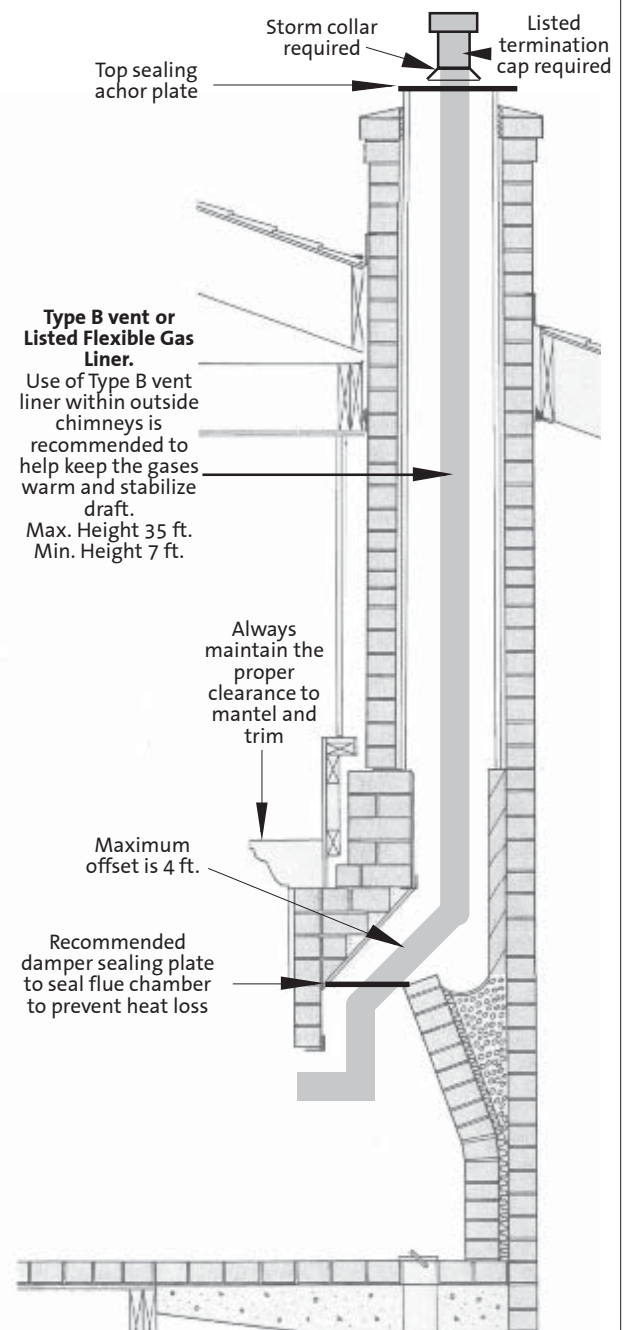

WARNING: FAILURE TO POSITION THE PARTS IN ACCORDANCE WITH THIS DIAGRAM OR FAILURE TO USE ONLY PARTS SPECIFICALLY APPROVED WITH THIS APPLIANCE MAY RESULT IN PROPERTY DAMAGE OR PERSONAL INJURY.

Figure 6. GF 400 BV venting through a masonry chimney.

Fuel Conversion

The GF 400 BV gas stove is shipped from the factory equipped to burn NATURAL GAS only. If PROPANE gas is to be used as fuel, the appliance must first be converted for use with propane. Use Propane Conversion Kit 156003, supplied with the appliance.

Order and install NG Conversion Kit 156004 to change back to use with natural gas.

WARNING:

THE CONVERSION KIT IS TO BE INSTALLED BY AN AUTHORIZED JØTUL SERVICE TECHNICIAN IN ACCORDANCE WITH THE MANUFACTURER'S INSTRUCTION AND ALL CODES AND REQUIREMENTS OF THE AUTHORITY HAVING JURISDICTION. FAILURE TO FOLLOW THESE INSTRUCTIONS COULD RESULT IN SERIOUS INJURY OR PROPERTY DAMAGE. THE QUALIFIED AGENCY PERFORMING THIS WORK ASSUMES RESPONSIBILITY FOR THIS CONVERSION.

IN CANADA:

THE CONVERSION SHALL BE CARRIED OUT IN ACCORDANCE WITH THE REQUIREMENTS OF THE PROVINCIAL AUTHORITIES HAVING JURISDICTION AND IN ACCORDANCE WITH THE REQUIREMENTS OF THE CAN1-B149.1 AND .2 INSTALLATION CODE.

AVERTISEMENT:

Cet équipement de conversion sera installé par une agence qualifiée de service conformément aux instructions du fabricant et toutes exigences et codes applicables de l'autorité ayant la juridiction. Si l'information dans cette instruction n'est pas suivie exactement, un feu, explosion ou production de protoxyde de carbone peut

Conversion Kit Contents:

- 1, regulator tower labeled for propane
 - 3, regulator tower screws
 - 1, burner orifice (**3.20 mm for NG, #49 for LPG**)
 - 1, pilot orifice (**#51 for NG, #30 for LPG**)
 - Label A - to be completed and applied to the back of the stove
 - Label B - apply to the stove's Rating Plate
 - Small valve label - apply to valve body
- Conversion instructions are also shipped in the stove with the conversion kit.

Fuel Conversion Procedure

1. Turn off gas supply to stove.
2. Remove the stove Top Plate.
3. Disengage the two Glass Frame Latches at the top of the firebox. See illustration on page 5. Carefully lift the glass panel up and out of the stove.
4. If installed, remove the Embers and Log Set using care not to damage the fragile log parts.
5. Lift out the Burner Skirt shown in fig.11.
6. Reach under the stove and remove the Air Shutter wingnut from its stud. See fig. 12.

7. Lift out the Burner Plate: NOTE: There are no screws securing the Burner to the floor of the firebox. Pull the Air Shutter forward and lift the burner together with shutter up and out of the stove as a unit. See fig. 13.
8. Change the Burner Orifice. Using a 1/2" open ended wrench or deep-well socket, remove the burner orifice from its brass elbow housing and replace with the appropriate orifice supplied in the kit. See fig. 14.
9. Replace the Air Shutter and push it all the way back to allow replacement of the Burner Plate. Reattach the wingnut and gasket to the shutter stem under the stove, but do not tighten. You will set its final position later.
10. Replace the Burner Plate. Engage the burner tube with the Air Shutter assembly as in fig. 14. Be sure the burner is securely engaged with the two support brackets at the front of the firebox and push the plate back toward the rear of the firebox.
11. **CHANGE THE PILOT ORIFICE: From within the firebox, remove the Pilot Head by pulling it straight up from the pilot base.** See fig. 16. Using the 4 mm hex key included with the kit, unscrew the pilot orifice (counterclockwise). Replace with the appropriate orifice:
12. Tighten orifice into the base of the pilot assembly. To prevent bypass leaks, be sure the orifice is secured tightly and flush with the base. Replace pilot head by pushing it down onto the pilot base.
13. **Replace the Variable Regulator.** Using a Torx T-20 screwdriver, remove the three screws from the front of the valve regulator. See fig. 17.
14. Remove the regulator tower, gasket, white plastic disk, and spring. See fig. 17.

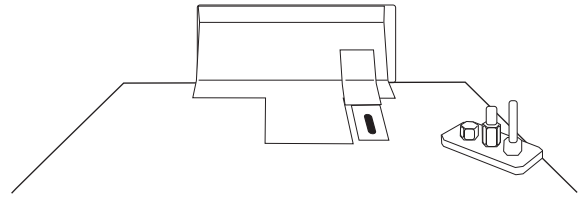

Figure 13. Remove the Air Shutter and Burner as a unit.

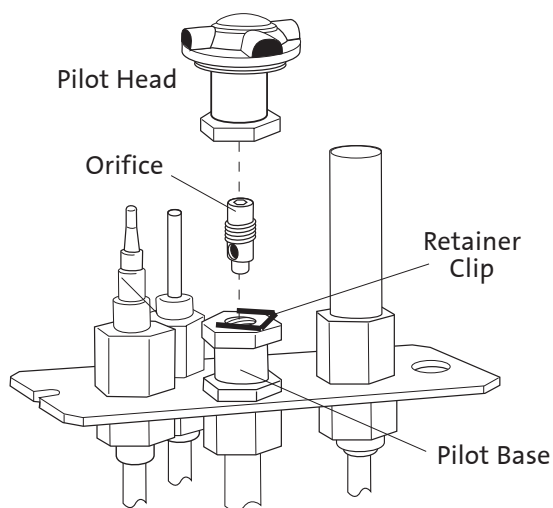

Figure 16. Pilot orifice removal and replacement.

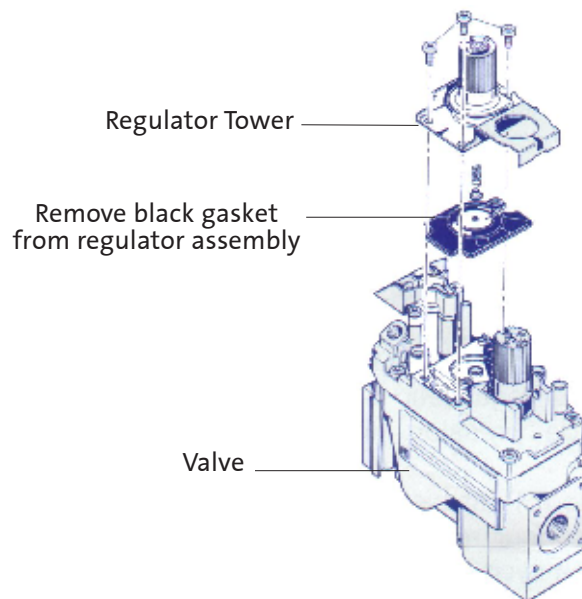

Figure 17 Regulator assembly.

15. **Install the new regulator:** Be sure the new gasket is properly positioned and tighten screws securely.
16. Install the identification labels to the stove so that they can be seen by any person that may be servicing the stove.
Label A: apply to back of stove.
Label B: apply to stove's rating plate.
Small valve Label: apply to valve.

17. Reassemble the stove, apply gas to the system and check for leaks using a soapy water solution or electronic gas detector.

NEVER USE AN OPEN FLAME TO CHECK FOR GAS LEAKS.

18. Correct gas pressure is essential for efficient and safe operation of this appliance. Use a manometer to check pressures as specified in the Gas Pressure section of this manual (page 15).

19. **Adjust the Air Shutter.** You will need to position the shutter to provide a gas/air mixture that will achieve the best flame picture with your particular installation. Start with the shutter stem at the half-way position in the slot in the bottom of the stove. See fig. 12. Pushing the stem back will restrict air, while pushing it forward will open the shutter and increase air. With some experimentation, you will find the shutter position that works best for your installation.

ALWAYS REFER TO THE LIGHTING INSTRUCTIONS ON THE INSIDE BACK COVER OF THIS MANUAL WHEN LIGHTING YOUR STOVE.

Gas Supply Connection

BLOWER NOTE: Install the optional blower before connecting the gas line in order to ensure adequate clearance between both.

The gas supply line connection is made to the left side of the front-mounted valve. The gas supply line should be 3/8" npt with a 1/2" diameter supply, or the appropriate size to provide sufficient gas pressure to the valve regardless of the input setting.

The use of Flexible Gas Appliance Connectors is acceptable in many areas in the U.S. However, Canadian methods vary depending on local code.

ALL INSTALLATIONS MUST COMPLY WITH LOCAL CODE OR IN THE ABSENCE OF LOCAL CODE, MUST COMPLY WITH THE MOST RECENT EDITION OF THE NATIONAL FUEL GAS CODE ANSI Z223.1/NFPA 54 OR CAN-B149.

All codes require a gas shut-off valve (gas cock) and union, to be installed in the supply line, and in the same room as the appliance. This allows for the disconnection of the stove for servicing and maintenance. See fig. 18.

A T-HANDLE GAS COCK IS REQUIRED IN MASSACHUSETTS TO COMPLY WITH CODE 248CMR.

Secure all joints tightly using appropriate tools and sealing compounds. For propane units be sure to use compounds that are propane resistant. Turn on gas supply and test for gas leaks using a soapy water solution. Never use an open flame to check for leaks.

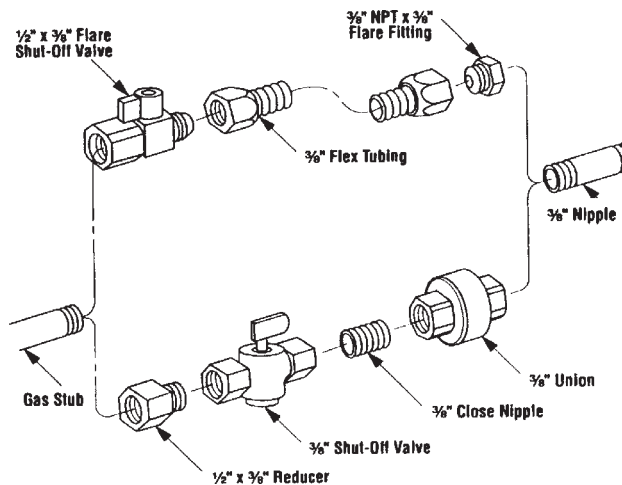

Figure 18. Supply valve connection fittings.

Leak test:

1. Mix a 50-50 solution of water and dish soap.
2. Light appliance- see lighting instructions on the inside back cover of this manual or on the stove's rating plate.
3. Brush or spray all joints and connections with the soapy water solution.
4. If bubbles appear at any connection or seam or a gas odor is detected, immediately turn gas control knob to the OFF position.
5. Tighten or reconnect the leaking joint and retest for any gas leaks.

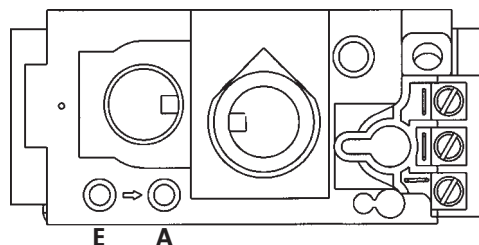

Figure 19. Pressure test points.

INLET GAS PRESSURES (inches water column)

	MIN	MAX
NATURAL GAS	5.0	7.0
PROPANE	12.0	14.9

The appliance and its appliance main gas valve must be disconnected from the gas supply piping system during any pressure testing on that system at test pressures in excess of 1/2 psig (3.5 kPa).

The appliance must be isolated from the gas supply line by closing its individual manual gas shut-off valve (gas cock) during any pressure testing of the gas supply piping system that is equal to or less than pressures of 1/2 psig (3.5 kPa).

MANIFOLD PRESSURES (inches water column)

	MIN	MAX
NATURAL GAS	1.2	3.8
PROPANE	2.9	11.0

Gas Pressure

Correct gas pressure is essential for efficient and safe operation of the GF 400 BV gas stove. It is important that the correct pressure is established at the time of the installation. Proper gas pressure provides a consistent flow of gas to the appliance and is instrumental in checking for gas leaks.

Pressure Test: Attach a manometer to the appropriate test point on the valve. See fig. 19. The gauge connections are located on the front of the valve under the On/Off/Pilot- knob. Gauge connections are identified by:

E - for **Inlet** or **Supply Pressure** (the amount of gas coming to the valve.)

A - for **Manifold Pressure** (the amount of gas that is coming out of the valve to the burner.)

ALWAYS TEST PRESSURES WITH VALVE CONTROL KNOB SET ON HIGH.



Flame Appearance / Air Shutter Adjustment

The GF 400 BV gas stove is shipped from the factory equipped to burn Natural gas. If the stove has been converted for use with propane, the Air Shutter may require adjustment to achieve the desired flame appearance. Other installation related variables can also affect the flame picture. The Air Shutter may be opened or closed to provide the best flame picture for your specific installation.

Too large an air opening - the appliance will generate a flame that is blue and transparent, or an “anemic” flame.

Too small an air setting - the appliance will generate very long yellow flames resulting in soot. Sooting produces black deposits on the logs, on the inside walls of the appliance, and potentially on the exterior termination cap. Sooting is caused by incomplete combustion in the flames and lack of combustion air entering the air shutter opening.

To adjust the air shutter:

1. Reach under the right side of the stove and loosen the wingnut located closest to you. See fig. 25. Slide the wingnut stud forward to open the air shutter and back to provide less air. Make adjustments in small increments.
2. Tighten the wingnut to secure the shutter at the desired setting.
3. Allow the stove to burn for 30 minutes on the HIGH setting, observing the flame continuously. If the flame appears weak, slow, or sooty, repeat the process described above until the flame is as desired.

WARNING: AIR SHUTTER ADJUSTMENTS SHOULD ONLY BE PERFORMED BY A QUALIFIED PROFESSIONAL SERVICE TECHNICIAN.

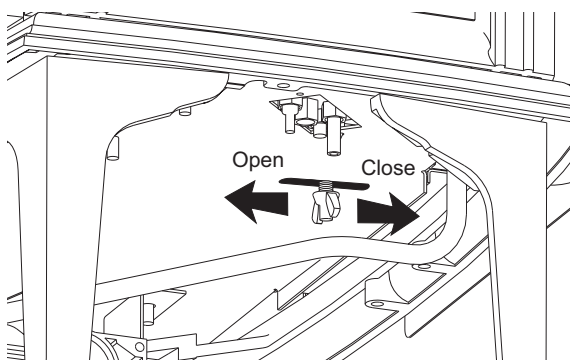

Figure 25. Loosen the wingnut to adjust the air shutter.

Optional Wall Thermostat or Remote Control

Use only a 750 millivolt DC two-wire circuit thermostat with this appliance. The thermostat should be placed in the same room as the heater, typically 5 feet off the floor. Avoid drafty areas or any area that may affect the accuracy of the thermostat.

The thermostat should be connected to the GF 400 BV using a minimum of 16 gauge wire with a maximum length of 25 feet of wire.

Connect the two thermostat wire leads to the two left terminals on the terminal block located directly above the ignitor button. Do not overtighten the connections. IT IS NOT NECESSARY TO DISCONNECT ANY OTHER WIRES. See Fig. 26.

For thermostatic operation, the On/Off/T-Stat switch on the back of the stove must be in the T-stat position, and the pilot light must be running, as it is the power source for the thermostat.

At the thermostat, the two wires should be connected to the two connection screws on the thermostat base plate per the manufacturer’s instructions.

Remote Control

When using a remote, the remote receiver should be wired to the terminal block the same way the thermostat would be. See the instructions above.

Follow the operating instructions included with the Remote Control unit.

CAUTION:

LABEL ALL WIRES PRIOR TO DISCONNECTION WHEN SERVICING THE CONTROLS. WIRING ERRORS CAN CAUSE IMPROPER OR DANGEROUS OPERATION. ALWAYS VERIFY PROPER OPERATION AFTER SERVICING THE APPLIANCE.

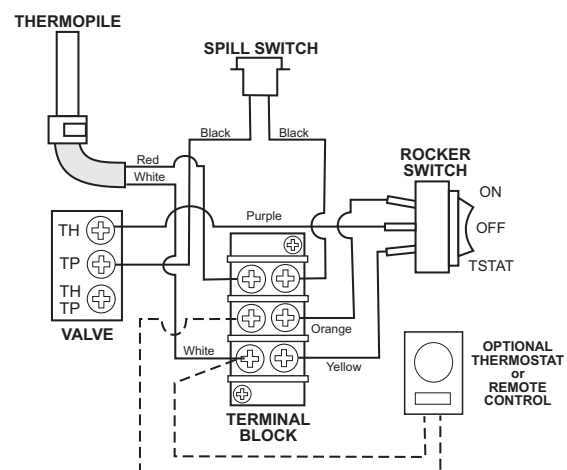

Figure 26. Valve and Accessory wiring diagram.

Installing Decorative Pipe

The use of decorative pipe is optional. No decorative pipe is included with the Jøtul GF 400 BV Sebago, however, four locator brackets are included with the stove in the hardware bag. The brackets are used to center the decorative pipe over the draft hood on which the pipe rests. Follow the procedure below to attach the brackets to the stove.

1. Remove the four 1/4" hex head screws that attach the 4" Flue Collar to the draft hood, but do not remove the Flue Collar. See Figure 27.
2. Align the "L"-shaped pipe brackets with the holes on the Flue Collar and attach using the four 1/4" hex head screws, located in the Misc. Hardware Bag.

Reminder: Do not use single wall stove pipe as the vent pipe on this appliance.

System Check

1. **PURGING THE GAS LINE:** When lighting the appliance for the first time, it will take a few moments to clear the gas line of air. Once this purge is complete, the appliance will operate as described in the lighting instructions. See the inside back cover of this manual or the stove Rating Plate attached the bottom of the stove. Subsequent burner starts will not require purging the gas line unless the supply line is shut off.
2. **PILOT FLAME:** You can monitor the pilot flame through the view port located at the rear of the Right Log. See fig. 28. The pilot flame should be steady - not lifting or floating. The flame should be blue in color around the pilot hood, with traces of yellow toward the outer edges.
The pilot flame should engulf the top 3/8" of the thermopile (to generate millivolt current) and the top 1/8" of the thermocouple. The pilot flame should project out of the pilot hood 1" at all three ports. See fig. 28.
3. **BURNER ADJUSTMENT:** This stove is equipped with a variable gas control valve that allows easy adjustment of the flame height appearance and heat

WARNING:
AIR SHUTTER ADJUSTMENTS SHOULD ONLY BE PERFORMED BY A QUALIFIED PROFESSIONAL SERVICE TECHNICIAN.

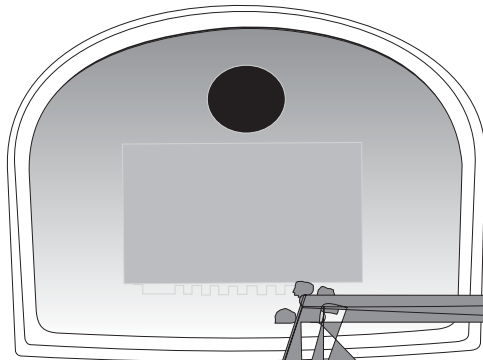

Figure 29. Flame appearance of burner in “rich” setting after approximately 15 to 20 minutes of burn.

CAUTION:
DO NOT ATTEMPT TO ADJUST THE FLAME APPEARANCE BY PRESSING THE VALVE CONTROL IN ANY MANNER OTHER THAN THE MANNER SHOWN.

Operation

- Familiarize yourself with the controls. Be sure that any adjustments are made in accordance with the instructions. Follow the instructions for lighting the burner. When the burner is lit, the spill switch located on the side of the burner is shown in fig. 30.
- OFF - use for manual control of the burner.
 - ON - use for optional thermostatic or remote control operation. The burner will be controlled by the accessories.
- During the first few fires, you may notice odor and/or smoke from the stove. This is normal and results from burn-off of manufacturing residue and curing of materials. You may find it helpful to provide additional ventilation and fresh air to alleviate this condition.
3. Condensation may occur on the glass upon each lighting of the appliance. This “fog” will disappear as the appliance heats up.
 4. Keep the controls and the area under the appliance free of debris, vacuum this area frequently. Always keep the appliance area clear and free from combustible materials, gasoline and other flammable liquids.

If a vacuum is used during any service on the stove, ALWAYS be sure the stove is cold and there are NO hot embers.

5. Remember, this appliance has a continuous burning pilot flame. Exercise caution when using products having combustible vapors. Always shut-off gas supply while servicing the stove.
6. **CAUTION: DO NOT OPERATE THIS APPLIANCE WITH THE GLASS REMOVED CRACKED OR BROKEN.** Replacement of the glass should be done by a licensed or qualified service person. Use only replacement glass provided by your authorized Jøtul dealer. Never use any substitute materials.

WARNING: OBSERVE CAUTION WITH THE GLASS. THE GLASS PANEL MAY SHATTER UNEXPECTEDLY IF STRUCK.

WITH CARE. WHEN SERVICING THE STOVE ALWAYS PULL THE GLASS ASSEMBLY STRAIGHT UP FOR REMOVAL.

7. Clean the glass only when necessary. Wipe surface with a clean, damp soft cloth. Follow with a dry, soft towel as desired. Take care not to scratch the glass surface.
- WARNING: DO NOT USE ABRASIVE CLEANERS ON THE GLASS. NEVER CLEAN THE GLASS WHEN IT IS HOT.**

BLOCKED FLUE SWITCH

NOTE: This appliance is equipped with a Spill Switch which will disable the burner in the event that the vent system becomes blocked. Located on the side of the Draft Hood, at the back of the stove, the switch has a reset button that, when pressed, will re-enable burner function. See Fig. 27.

If the Spill Switch repeatedly shuts the burner off, turn off the gas supply and call your dealer or service technician. The Spill Switch will continue to shut off the burner until the vent problem has been corrected. Not all vent problems can be corrected as B-Vent appliances are affected by atmospheric conditions and house pressurization.

Figure 30. Burner Switch and Optional Blower Controls

Maintenance

Your Jøtul GF 400 BV Sebago and its venting system should be inspected before use and at least annually by a qualified service technician.

Use the form on page 26 to keep a maintenance history of your stove.

IMPORTANT:

ALWAYS TURN OFF THE GAS SUPPLY TO THE FIREPLACE AND UNPLUG THE FORCED AIR BLOWER BEFORE ANY SERVICE WORK IS PERFORMED ON THE FIREPLACE.

Annual Cleaning

Vent System

The entire vent system, including the chimney, should be inspected and cleaned every year. If the intake and exhaust venting is disassembled for any reason, it should be reassembled and sealed according to the manufacturer's instructions provided at the initial installation.

Burner and Logset

Periodically inspect the Firebox, Valve Compartment, Convection Airways and optional Blower to BE CERTAIN THAT THE FLOW OF COMBUSTION AND VENTILATION AIR IS UNOBSTRUCTED.

The firebox should be vacuumed annually to remove any surface build up. Use a soft brush attachment and handle the logs carefully as they are fragile. Be sure to vacuum or wipe off the pilot assembly and burner surfaces.

Glass Care

Clean the glass only when necessary. Wipe the surface with a clean, dampened, soft cloth. Follow with a dry, soft towel. Take care not to scratch the glass surface.

WARNING:

DO NOT USE ABRASIVE CLEANERS ON THE GLASS. NEVER CLEAN THE GLASS WHEN IT IS HOT.

Gasket Inspection

It is important that the glass gasket be inspected at least annually. Examine the ribbon gasket for signs of deterioration and make sure the gasket has a positive seal. Replace the gasket if necessary. Refer to the replacement parts list on page 25.

FOR REPLACEMENT, USE ONLY JØTUL CERAMIC GLASS REPLACEMENT KIT 155599. DO NOT USE ANY OTHER TYPE OF GLASS WITH THIS APPLIANCE.

Glass Panel or Gasket Removal

1. Lift the Top Plate off of the stove.
2. Release the two Glass Frame Latches. Pull each latch handle forward to disengage the latch from the notches in the glass frame.
3. Lift the glass frame all the way up and out of the top of the stove. Lay this assembly on a flat surface, protecting the frame from scratches using a blanket or towel.
3. The glass panel is held in place by four compression clips. Use a screwdriver or small pliers to pry these up off the edge of the glass retaining walls. See fig. 31.
4. Remove the old gasket material. See fig. 32.

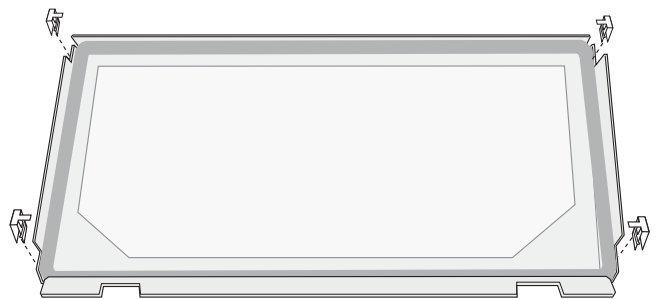

Figure 31. Use small pliers remove the four clips.

Glass Panel or Gasket Replacement

1. Wrap the new gasketing material evenly around the edge of the glass, peeling back the protective strip to expose the adhesive as you go. Press the adhesive side down onto the glass surface. Do not stretch the gasket.
2. Place the gasketed glass within the frame and press each of the retainer clips back into place on the retainer walls.

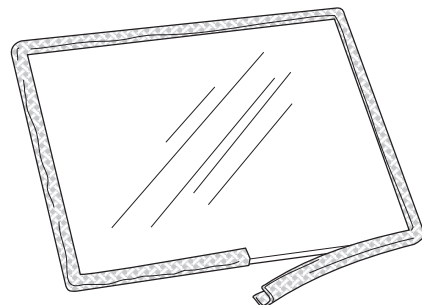

Figure 32. Wrap the gasket around the glass panel.

er

ne to th
ver.
rol valve t
lower insta

contents of th
ny damage is
fig. 33.

Bracket to the s
box floor using
m wrench. See f

Bracket to the sto
d hex bolts as sho

reflectors using the
with the finger guar
n place. See #7 and #

er with the duct oper
d. See fig. 35. Feed the
Bracket opening and sec
t with the wingscrew.

er Snapstat wire connecto
r terminal. See fig. 35.

napstat by sliding it all th
ottom of the Snapstat Bra
nd 35.

e male wire harness connec
e harness connector already
ee fig. 35.

ower cord to outlet.

**BLOWER MOTOR
ELECTRICALLY
CORDANCE
IN THE
ES, V
A 7**

NG

**WAYS D
OV
PLY WHEN
NG A
VICE ON THE
PLACE
ERT.**

stat and Blower Brackets.

Figure 35. Attach Blower to the Mounting Bracket with the wingscrew and connect wires to Snapstat and female control quickconnect.

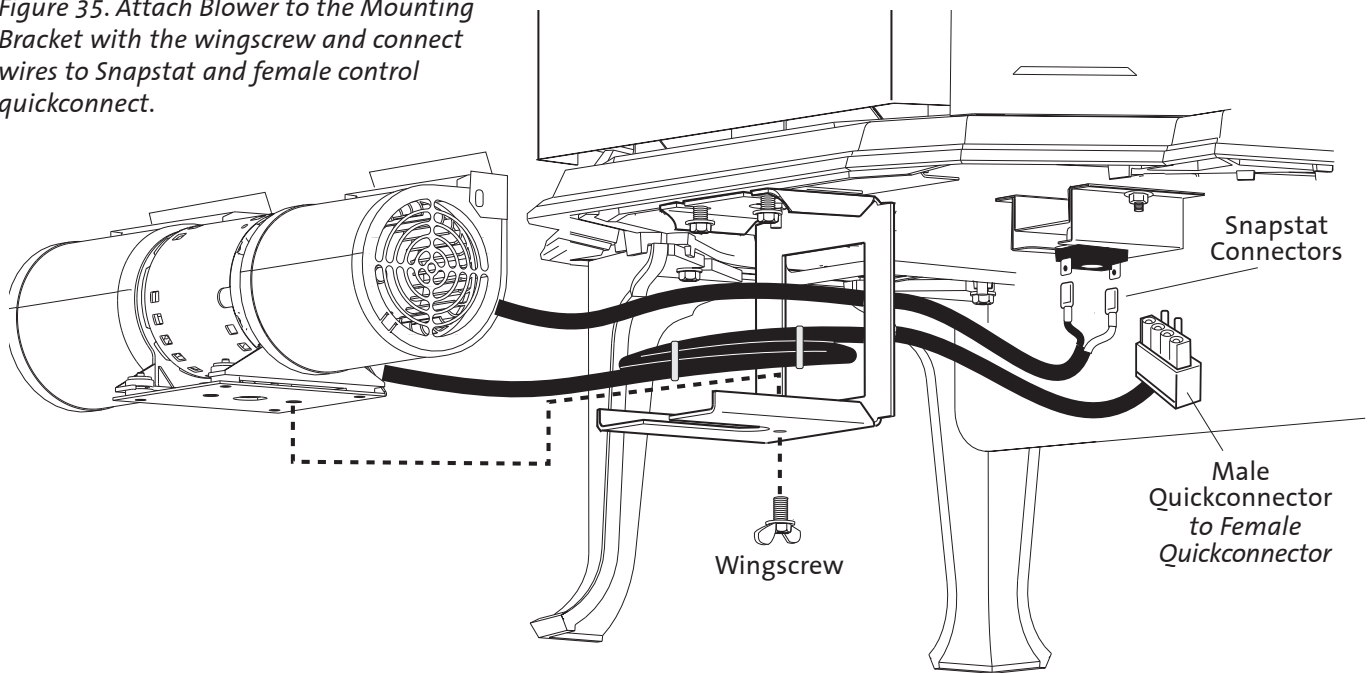

Blower Operation

The optional variable-speed blower will enhance heat circulation around the firebox and out into the room. The blower is controlled by a heat activated switch (snapstat) that will ONLY function when the control switch is in AUTO setting. After the fire has been burning for a time, the snapstat will react to the heat and activate the blower. Fan speed may be manually adjusted with the rheostat knob. If the burner turns off, the blower will be shut off automatically when the stove cools down.

If automatic blower circulation is not desired, place the blower control switch in the MANUAL position.

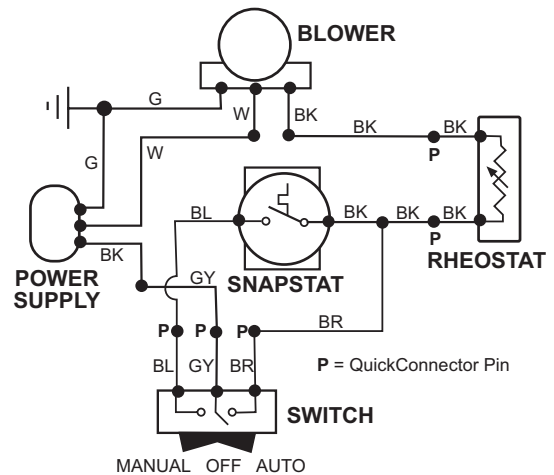

Figure 37. Blower Wiring Diagram

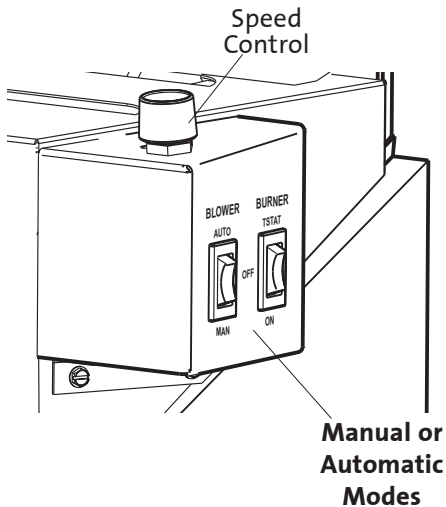

Figure 36. Blower Controls

CAUTION:

LABEL ALL WIRES PRIOR TO DISCONNECTION WHEN SERVICING CONTROLS. WIRING ERRORS CAN CAUSE IMPROPER AND DANGEROUS OPERATION.

VERIFY OPERATION AFTER SERVICING.

ATTENTION:

Au moment de l'entretien des commandes, étiquetez tous les fils avant le débranchement. Des erreurs de câblage peuvent entraîner un fonctionnement inadéquat et dangereux.

Optional Antique Brick Panel Kit #155375

Tools Required: Safety glasses and gloves

- 1. Remove the Top Plate.** Simply lift it up off of the stove body. It is not fastened.
- 2. Remove the Glass Frame.** Disengage the two compression latches located at the top of the firebox and lift the glass frame up and off of the stove. See Fig. 1.
- 3. Remove the Logset.**
These parts are not fastened. Simply lift them out of the firebox. You do not have to remove the embers.
- 4. Install the Rear Panel.**
Tilt the Rear Panel top first to slide behind the exhaust baffle and position it up against the back wall.
- 5. Install the Side Panels.** Tilt each panel, bottom edge first, into position against the side walls. The panels will stand on their own against the wall. Push them back against the Rear Panel.
- 6. Reinstall the Logset.**
See page 21. **BE CERTAIN THAT NO EMBERS ARE BLOCKING THE PILOT ASSEMBLY OPENING.**
- 7. Replace the Glass Frame.**
Slide the frame down the slot in the front of the firebox. Be sure to push the frame into the slot in the bottom to ensure it is fully seated. The gasket at the top of the frame should be flush with the top of the firebox.
Pull the compression latches out to engage with the top lip of the glass frame.
- 8. Replace the Top Plate.**

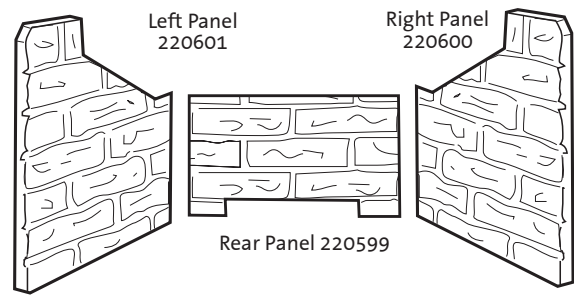

Figure 47. Brick Kit Contents

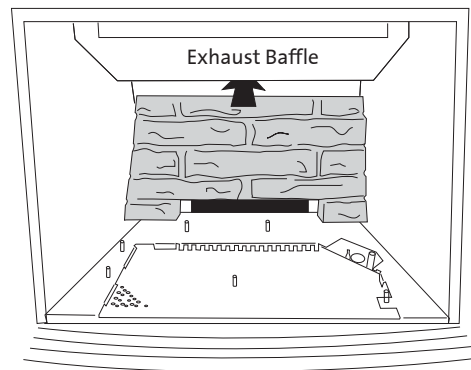
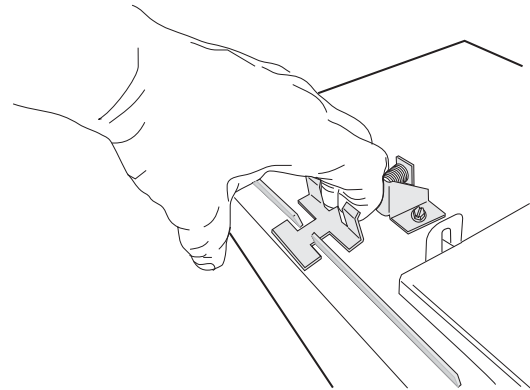

Figure 49. Install the Rear Panel to fit behind baffle.

Figure 50. Install the Side Panels.

High Altitude Adjustment

Installations burning natural gas and located at altitudes from 2000 - 4500 ft. (610 M - 1370 M), require compensation for the thinner air (less volume of air per cubic foot). Higher altitudes affect the atmospheric pressure and heat value of gaseous fuels. The lower oxygen content in the air and the lower gas viscosity require the use of a different orifice to achieve efficient, clean combustion at the burner tube.

For high altitude installations consult the local gas distributor or the authority having jurisdiction for proper rating methods. If the installer must convert the unit to adjust for varying altitudes, use Jøtul High Altitude Kit, #155885-LP or # 155895 NG.

DO NOT DERATE THE BURNER FOR PROPANE.

In the U.S: THE DERATING KIT MUST BE INSTALLED BY AN AUTHORIZED SERVICE TECHNICIAN IN ACCORDANCE WITH THE MANUFACTURER'S INSTRUCTIONS AND ALL CODES AND REQUIREMENTS OF THE AUTHORITY HAVING JURISDICTION. THE INFORMATION STICKER MUST BE COMPLETED BY THE INSTALLER AND APPLIED TO THE APPLIANCE AT THE TIME OF THE CONVERSION. THE QUALIFIED SERVICE AGENCY PERFORMING THIS WORK ASSUMES RESPONSIBILITY FOR THIS DERATING.

In Canada: This unit has been tested for installation at high altitudes in accordance with Canadian test standard CAN/CGA-2.17. THE DERATING SHALL BE CARRIED OUT IN ACCORDANCE WITH THE REQUIREMENTS OF THE PROVINCIAL AUTHORITIES HAVING JURISDICTION AND IN ACCORDANCE WITH THE REQUIREMENTS OF THE CAN1-B-149.1 AND .2 INSTALLATION CODE.

AVERTISEMENT:

Cet équipement de conversion sera installé par une agence qualifiée de service conformément aux instructions du fabricant et toutes exigences et codes applicables de l'autorité ayant la juridiction. Si l'installateur dans cette instruction n'est pas suivie exactement, un feu, explosion ou production de protoxyde de carbone peut résulter le dommages causer de propriété, perte ou blessure personnelle de vie. L'agence qualifiée de service est responsable de l'installation propre de cet équipement. L'installation n'est pas propre et complète jusqu'à l'opération de l'appareil converti est chaque suivant les critères établis dans les instructions de propriétaire provisionnées avec l'équipement.

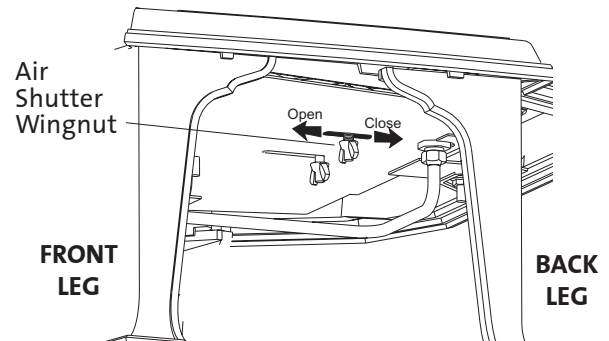

Figure 51. Locate and remove the Air Shutter wingnut from under the right side of the stove.

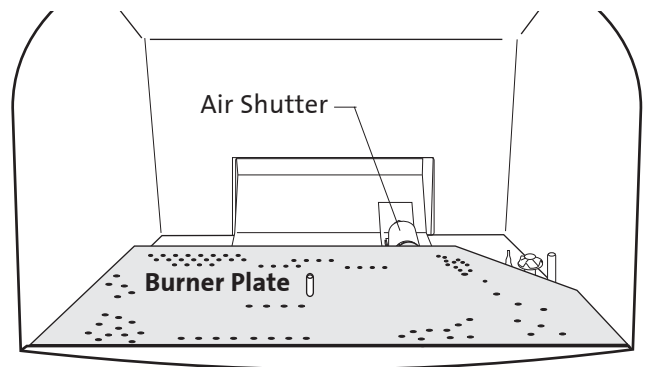

Figure 52. Remove the Air Shutter and Burner as a unit.

Derating Procedure

1. Follow Steps 1-10 of the Fuel Conversion procedure outlined on pages 11 and 12.
2. Replace the original orifice with the appropriate orifice in the kit: 3.10 mm NG or #51 LP.
3. Fill out the high altitude conversion label from the kit and attach to the rating plate or gas valve.
4. Reassemble the firebox components.
5. It may be necessary to adjust the air shutter on the burner tube. See AIR SHUTTER/FLAME APPEARANCE on page 16 for more details.



48 49 50 51

IT

Figure 44.

GF 400 BV Sebago Parts List

Cast Iron Parts	Matte Black	Blue Black Enamel	Ivory Enamel	Green Enamel	Jøtul Iron	Jøtul Iron Enamel
10. Left Side Plate	10391892	10391827	10391829	10391832	10391885	10391846
30. Base Plate	10396392	10396327	10396329	10396332	10396385	10396346
47. Legs, (4)	10192592	101966	102251	10392532	10192585	10192546
55. Front Plate	10396192	10396127	10396129	10396132	10396185	10396146
57. Left Door	10392992	103929527	10392929	10392932	10392985	10392946
60. Right Door	10407292	10407227	10407229	10407232	10407285	10407246
61. Right Side Plate	10391992	10391927	10391929	10391932	10391985	10391946
74. Top Plate	10396292	10396227	10396229	10396232	10396285	10396246

1. Cover Plate, Draft Hood	129183	44. Spacer, Pilot Asy	220546
2. Screw, #8 x 1/2" Hex	117917	45. Gasket, Pilot Asy	129670
3. Knob, Rheostat	220709	48. Control Door	2211892
4. Rheostat, 26" Leads	220970	49. Spacer	118040
5. Switch Box	221310	50. Fender Washer, 1.50 dia.	118029
6. Rocker Switch	220703	51. Bolt, M6 x 100 Hex	117955
7. Screw, #7 x 3/8" PH	117967	53. Spacer, .125 x .500	117994
8. Switch, Thermo-Spill	220916	54. Hinge, Control Door	221176
9. Lanyard, Rating Plate	129159	56.. Hinge Pin	125960
11. Bolt, M6 x 20 Flng Hd Hex	117117	58. Bolt, M6 x 10 Flange, Hex	9962
12. Burner Plate, SS	220545	59. Door Clip	220603
13. Gasket, burner	220633	62. Glass Frame	12972592
14. Plate, Burner Base	103991	63. Clip, Tinnerman	220042
15. Venturi Tube, Burner	220631	64. Gasket, Tadpole	129124
16. Tube Holder	103992	65. Glass, Ceramic	220567
17. Bolt, M6 x 20 Flng Hd Hex	117117	66. Firebox Assembly	22130492
18. Screw, 10-32 x 3/8" PH	117911	67. Blower Deflector	221307
19. Nut, M6 Flange	117968	68. Burner Skirt	22130892
20. Valve Bracket	220352	69. Burner Skirt Deflector	22132792
21. Gas Valve, NG 50% TD	220520	70. Log Set.....	155378
22. Ignitor Bracket	3902576	71. Hex Nut, M6.....	9630
23. Screw, M4 x8 PH.....	117920	72. Exhaust Baffle	22056592
24. Ignitor	3902573	73. Latch, Glass Frame	22009192
25. Bracket, Terminal Block - 3 Pole	220983	75. Rear Shroud	22130992
26. Nut, M4 Hex	117922	76. Draft Hood, Inner	22135592
27. Terminal Block, 3 Pole	118028	77. Draft Hood, Outer	22132192
28. Screw, M4 x 12	117921	78. Collar, 3 7/8" Starter	12918992
29. Brass Elbow, 90° 3/8" NPT	129129	79. Mantel Heat Shield	221366
31. Burner Assembly, Complete	155336	Ember Stones, 6 oz. (not illustrated)	220702
32. Flex Tube, Main Gas 5/16"	129390		
33.. Compression Nut	129464		
34. Compression Sleeve	129463		
35. Jam Nut - Orifice Holder	129152		
36. Orifice Holder	129668		
37. Burner Orifice, NG 3.20 mm	129681		
Burner Orifice, LP #49	129411		
38. Air Shutter	220790		
39. Gasket, 2.25 OD.	118023		
40. Wing Nut, M6	117975		
41. Washer, 2.25 OD	220734		
42. Screw, #8 x 3/4"	117986		
43. Pilot Assembly, NG	129471		

Accessories

Variable Speed Blower	156000
Brick Panel Kit	155375
Wall Thermostat	750003
Remote Control	750002
Floor Bracket Kit	750304
Fuel Conversion Kit to Propane	155351
Fuel Conversion Kit to Natural Gas	155352
High Altitude Adjustment Kit / LP	155885
High Altitude Adjustment Kit / NG	155895

Record the following information to help your dealer determine what you will need for parts and service.

MODEL NAME: GF 400 BV Sebago

SERIAL NUMBER: _____

DATE OF PURCHASE: _____

PURCHASED FROM: _____

NAME OF INSTALLER: _____

TYPE OF FUEL: _____

WAS STOVE CONVERTED? _____

NOTES:

**RETAIN THIS MANUAL FOR REFERENCE
AND MAKE IT AVAILABLE TO ANYONE
USING OR SERVICING THE STOVE.**

LIGHTING INSTRUCTIONS

FOR YOUR SAFETY, READ BEFORE LIGHTING.

WARNING:

IF YOU DO NOT FOLLOW THESE INSTRUCTIONS EXACTLY, A FIRE OR EXPLOSION MAY RESULT CAUSING PROPERTY DAMAGE, PERSONAL INJURY, OR LOSS OF LIFE.

- A.** This appliance has a pilot which must be lit by hand. When lighting the pilot, follow these instructions exactly.
- B. BEFORE LIGHTING,** smell all around the appliance area for gas. Be sure to smell next to the floor because some gas is heavier than air and will settle to the floor.

WHAT TO DO IF YOU SMELL GAS:

- Extinguish any open flame.
 - Open windows.
 - Do not light any appliance.
 - Do not touch any electrical switches.
 - Do not use any phone in your building.
 - Immediately call your gas supplier from a neighbor's phone.
- D.** Do not use this appliance if any part has been under water. Immediately call a qualified service technician to inspect the appliance and to replace any part of the control system and any gas control which has been under water.
- C.** Use only your hand to push in or turn the gas control knob. Never use tools. If the knob will not push in or turn by hand, do not try to repair it. Call a qualified technician. Force or attempted repair may result in a fire or explosion.

LIGHTING INSTRUCTIONS

1. STOP! Read the safety information above.
2. Access the lower controls.
3. Turn the stove ON/OFF switch to "OFF", or set the thermostat to lowest setting (if used).
4. Confirm that the gas supply line shut-off valve is open.

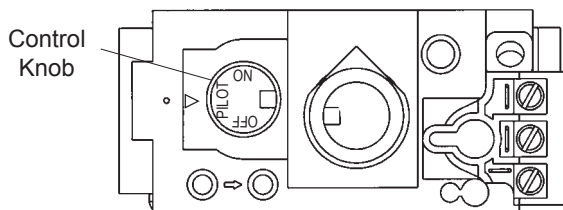

Control Valve

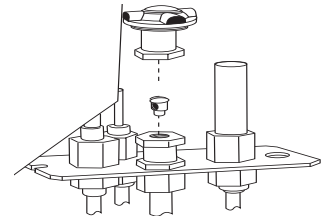

5. Push in gas control knob slightly and turn clockwise ➡ to "OFF".
NOTE: Knob cannot be turned from "PILOT" to "OFF" unless the knob is pushed in slightly. Do not force.
6. Wait five (5) minutes to clear out any gas. If you then smell gas, STOP! Follow "B" in the safety information above on this page. If you do not smell gas, go to the next step.

TO TURN OFF GAS TO THE APPLIANCE:

1. Turn ON/OFF switch to "OFF". The pilot will remain lit for normal service.
2. For complete shutdown, turn ON/OFF switch to "OFF".
3. Access the lower controls.
4. Depress gas control knob slightly and turn clockwise ➡ to "OFF". Do not force.

November 2005
138301-B

This appliance must be installed in conformance with local and national building regulations. Before beginning the installation, it is important that these instructions be carefully read and understood. Jøtul maintains a policy of continual product development. Consequently, products may differ in specification, color or type of accessories from those illustrated or described in various publications.

Jøtul vise sans cesse à améliorer ses produits. C'est pourquoi, il se réserve le droit de modifier les spécifications, couleurs et équipement sans avis préalable.



Jøtul ASA
P.O. Box 1411
N-1602 Fredrikstad
Norway

Jøtul North America
55 Hutcherson Drive
Gorham, Maine 04038-2634