

IRONMAN®

Owners Manual Power 10 Magnetic Rower

POWER 10

Customer Service
(800) 750-4766
Assembly
(888) 559-8810

Manufactured by:
Ironman Fitness Products
4009 Distribution Drive
Suite 250
Garland, TX 75041

www.ironmanfitness.com

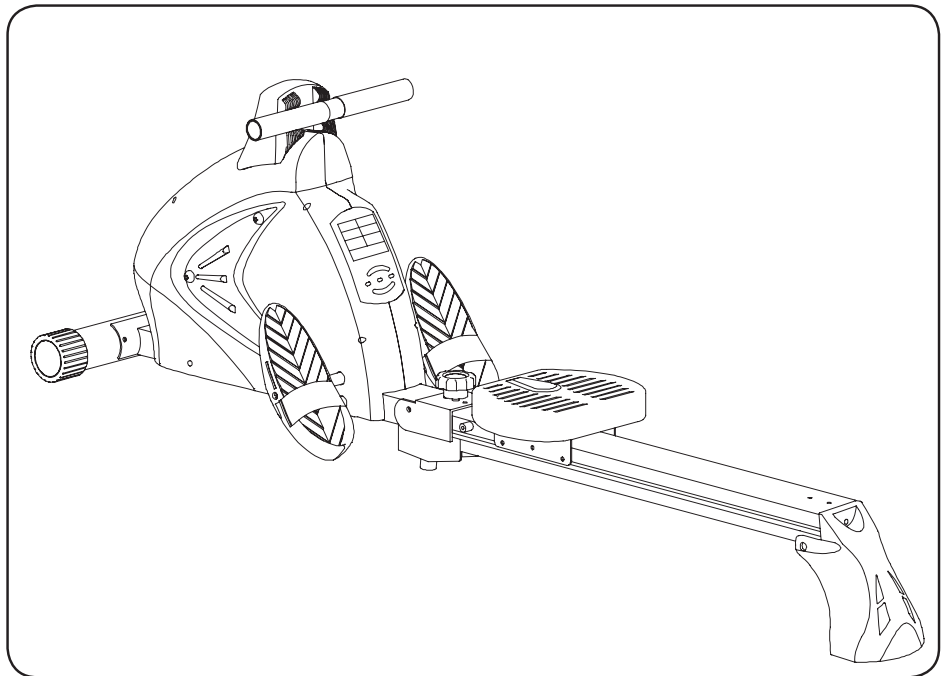

715-00001
03/19 Rev C

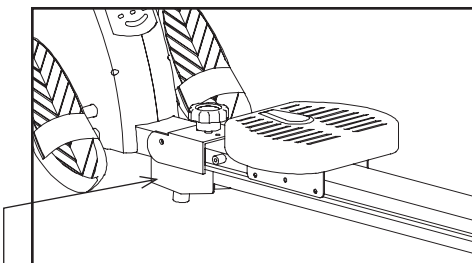

Serial tag is located on the side of the track

Model Name: _____

Date of Purchase: _____

Serial Number: _____

Caution!

Read all precautions and instructions in this manual before using this equipment.

Table of Contents	2
Important Safety Information	3
Getting Started	4
Assembly Steps	5
Parts Identifier	5
Assembly Steps	5
Console Instructions	9
Warm Up Exercises	14
Monitoring Your Heart Rate	17
Workout Information	19
Frequency: How Often Should You Exercise	19
Intensity: How Hard Should You Exercise	19
Weight Management	18
Exercise Practice Procedures	19
Workout: Brisk and Rhythmic Exercise	20
Cool Down: Slow and Relaxed Exercise	20
Chest Strap Information	21
Notes	22
Parts List	25
Exploded Views	26
Warranty	27

WARNING! Before using this unit or starting any exercise program, consult your physician. This is especially important for persons over the age of 35 and/or persons with pre-existing health problems. The manufacturer or distributor assumes no responsibility for personal injury or property damage sustained by or through the use of this product.

WARNING! To reduce the risk of electrical shock, burns, fire, or other possible injuries to the user, it is important to review this manual and the following precautions before operation.

SAFETY PRECAUTIONS AND TIPS

1. It is the owner's responsibility to ensure that all users of this unit have read the Owner's Manual and are familiar with warnings and safety precautions.
2. This unit has a user maximum capacity of **275** pounds.
3. The unit should only be used on a level surface and is intended for indoor use only. The unit should not be placed in a garage, patio, or near water and should never be used while you are wet. Ironman Fitness recommends a mat be placed under the unit to protect floor or carpet and for easier cleaning.
4. Follow safety information in regards to plugging in your unit. Do not run the power cord underneath your unit. Do not operate the unit with a damaged or frayed power cord.
5. Wear comfortable, good-quality walking or running shoes and appropriate clothing. Do not use the unit with bare feet, sandals, socks or stockings.
6. Always examine your unit before using to ensure all parts are in working order.
7. Allow the unit to fully stop before dismounting.
8. Pets should never be allowed near the unit.
9. Do not leave children unsupervised near or on the unit.
10. Never operate the unit where oxygen is being administered, or where aerosol products are being used.
11. Never insert any object or body parts into any opening.
12. For safety and to prevent damage to your unit, no more than one person should use the unit at a time.
13. Always unplug the unit before cleaning and/or servicing. Service to your unit should only be performed by an authorized service representative, unless authorized and/or instructed by the manufacturer.
14. Failure to follow these instructions will void the unit warranty.

(..cont.)

Thank you for purchasing the Ironman Fitness **Power 10 Magnetic Rower!** The quality product you have chosen was designed to meet your needs for cardiovascular exercise. Before you start, please read the Owner's Manual and become familiar with the operation of your new unit. Remember to take time to perform stretching exercises, provided in this manual, to help avoid injury.

If you are taking medication, consult your physician to see what effect the medication will have on your exercise heart rate.

If you have heart problems, you are not active, and/or are over the age of 35 years, do not use the pre-set programs or start an exercise program without first contacting and receiving approval from your physician. To avoid the risk of electrical shock, always keep the console dry. Do not spill liquids on the console. Ironman Fitness recommends a sealed water bottle for beverages consumed while using the unit.

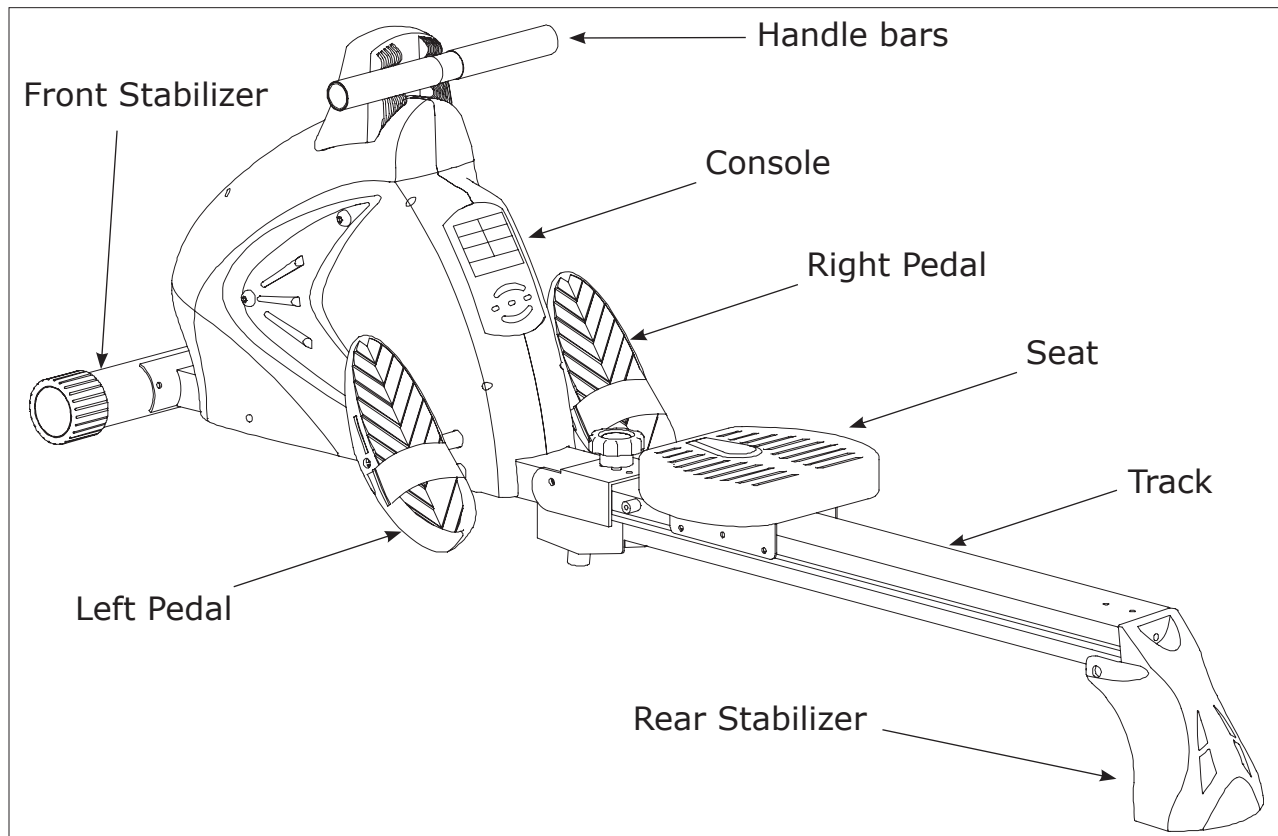

Getting Started

The Ironman Fitness **Power 10 Magnetic Rower** will require some assembly. Unpack the box in a clear area. Remove packing material. Do not dispose of packing material until assembly is complete and unit is working properly. Place the unit on a clean level surface for assembly. Make sure there is easy access to an electrical outlet. Before assembling, the unit should be placed as close as possible to its final location. If you are missing any parts, please call Ironman Fitness at **1-800-750-4766**. Tools have been provided to assist with product assembly.

Parts Identifier

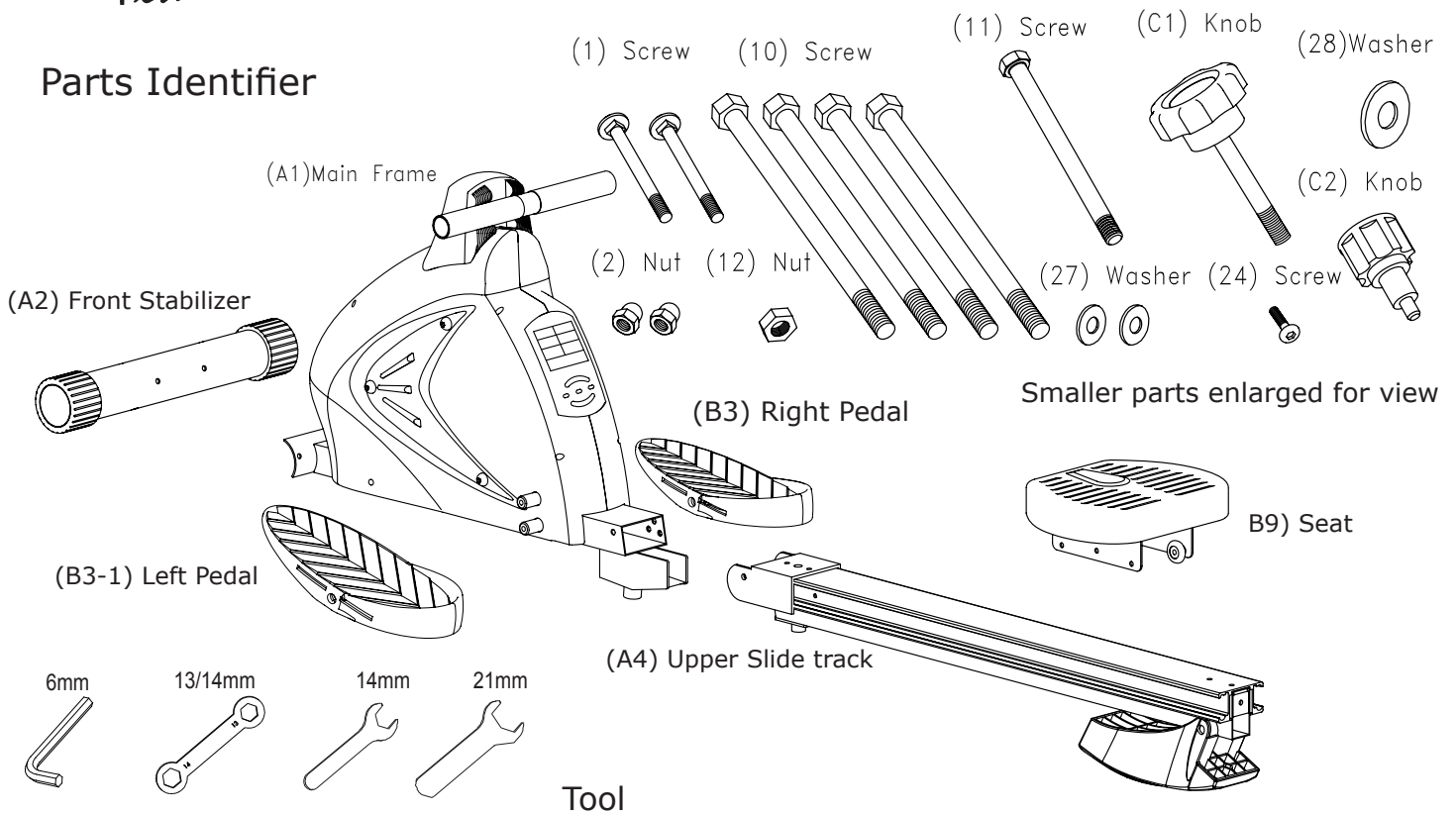

Assembly Steps

1 Figure 1
Assembly for front stabilizer with main frame

Step 1. Secure the front stabilizer (A2) and main frame (A1) using carriage bolts (1) & Nuts (2), and Washers (27).

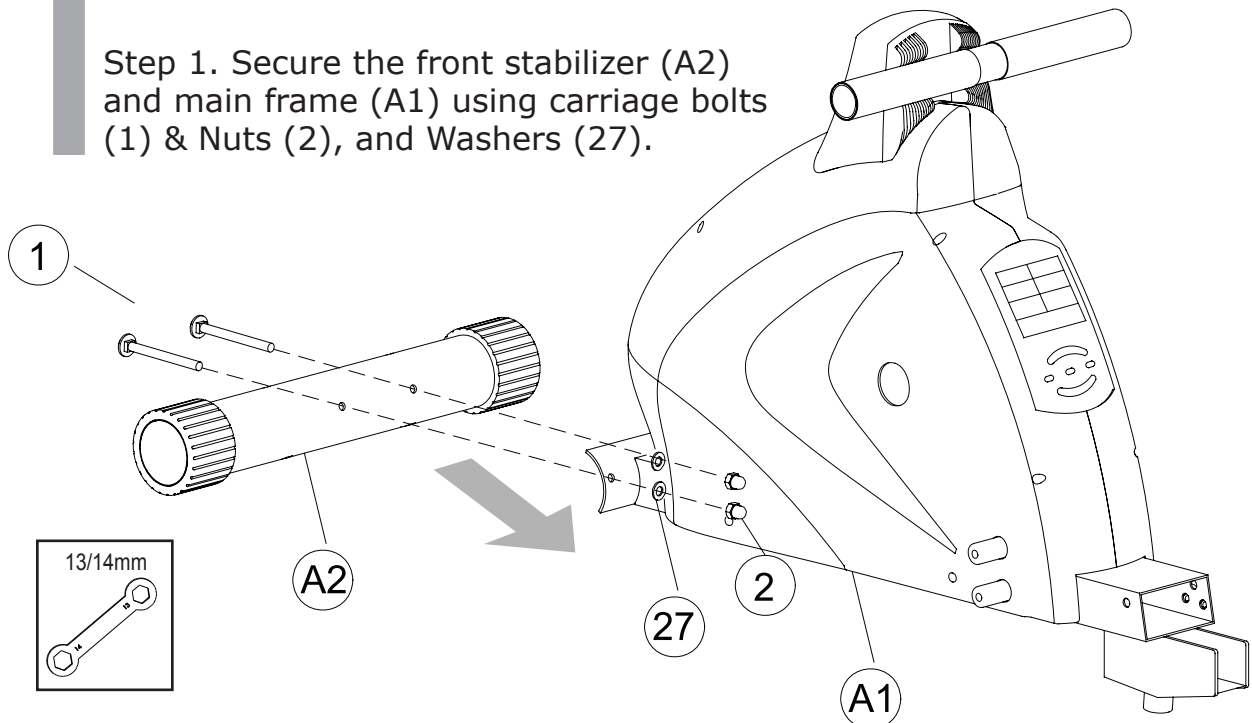

2

Figure 2

Assembly for upper track

Step 1. Secure main frame (A1) with upper slide track (A4) using bolt (11), Nut (12) and tight it by knob (C2).

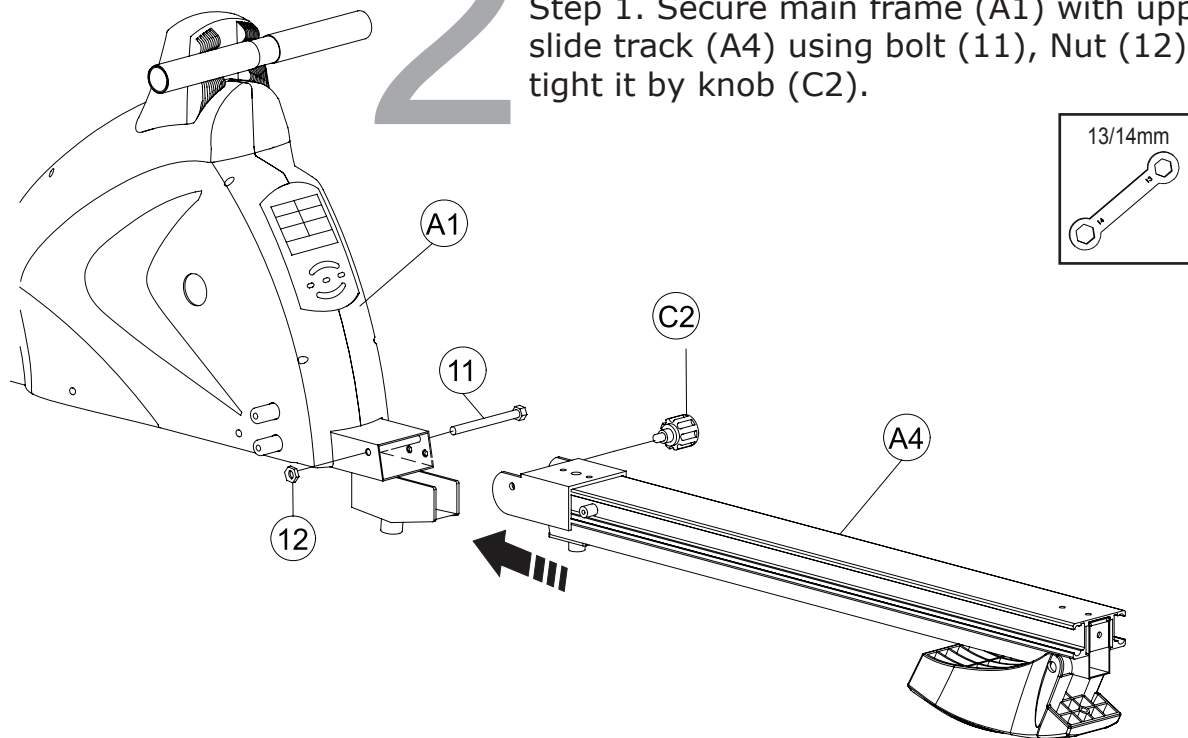

3

Figure 3

Assembly for Wireless Pulse Receiver

Step 1. Lift up the Power 10 slide track by pulling out knob (C2). Once the slide track is in place, release knob (C2) to secure it in the elevated position.

Step 2. Connect cable (D8) & wireless pulse receiver (C5).

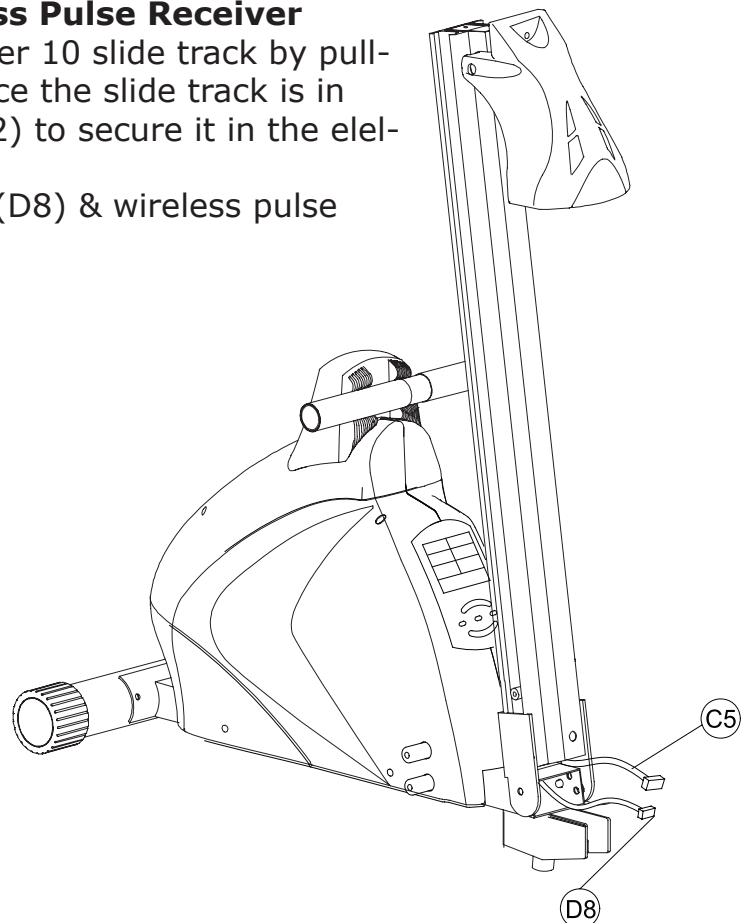

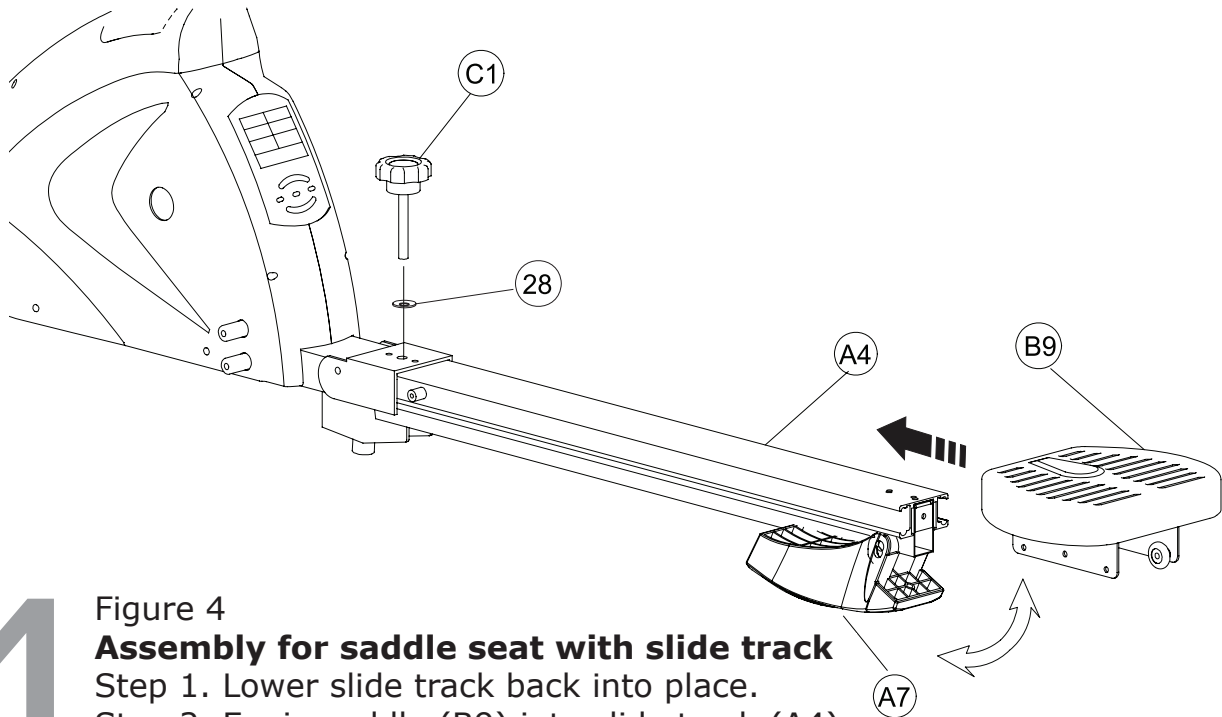

4

Figure 4

Assembly for saddle seat with slide track

- Step 1. Lower slide track back into place.
- Step 2. Equip saddle (B9) into slide track (A4).
- Step 3. Fold up rear stabilizer (A7)
- Step 4. Secure the knob with (C1) and washer (28).

5

Figure 5

Assembly for pedals

- Step 1: Insert shaft bolt (10) into pedal (B3) and secure it into main frame.
- Step 2: Use screw (24) to secure rear stabilizer to slide track.

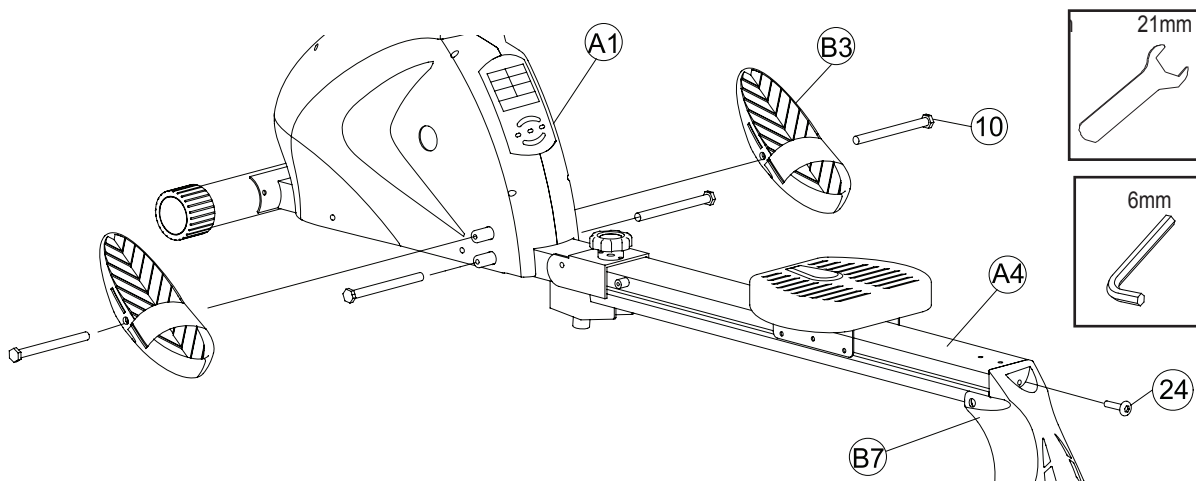

6

Figure 6

How to fold your Power 10

Step 1. Lift up the Power 10 from it's original extended position. While holding it in an upright position unscrew the (C1) fix knob that secures the track.

Step 2. Gently lay it back down and pull the knob (C2) to release the Slide track (low) to raise it. You can place the fix knob back into the hole while its at a slight angle and fold it compactly in with the unit.

The knob (C2) shall secure the Power 10 Rower for storage.

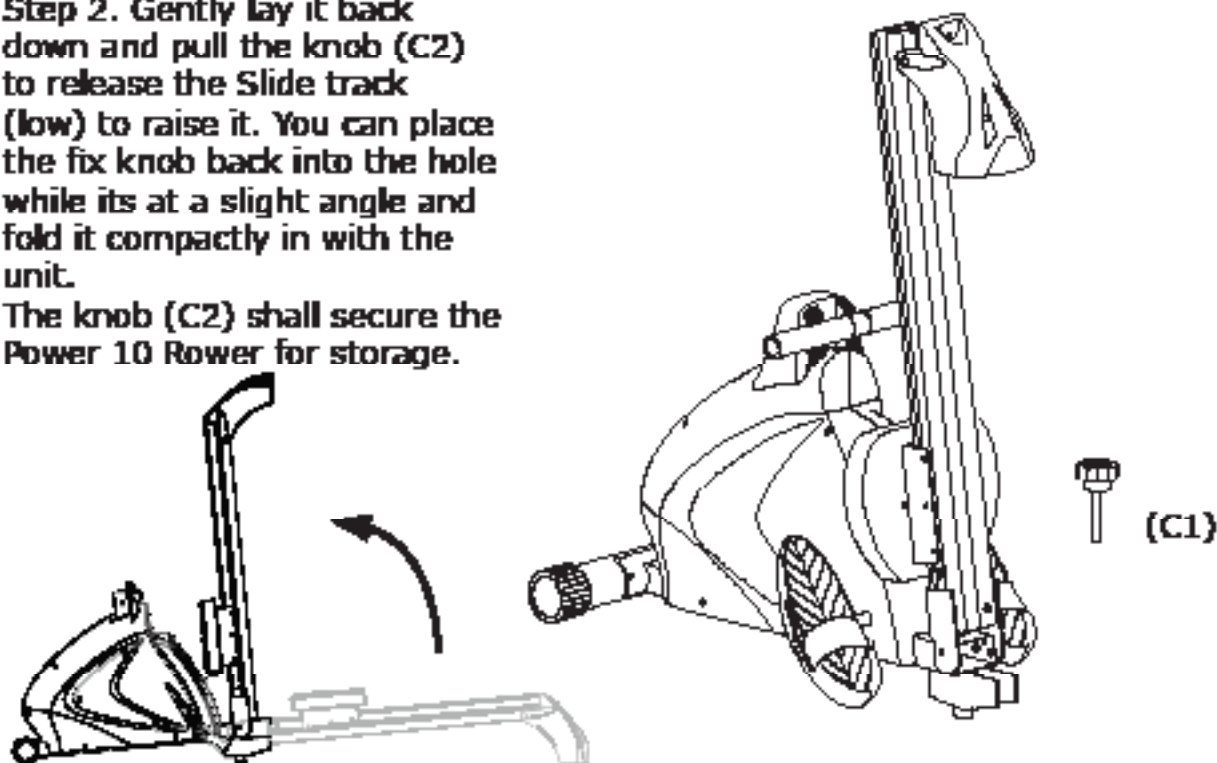

7

Figure 7

How to move your power 10

Step 1: Lift up the Power 10 rower till it's on the front stabilizer wheels.

Step 2: Use the rear stabilizer as an anchor to push the power 10 to its desired position

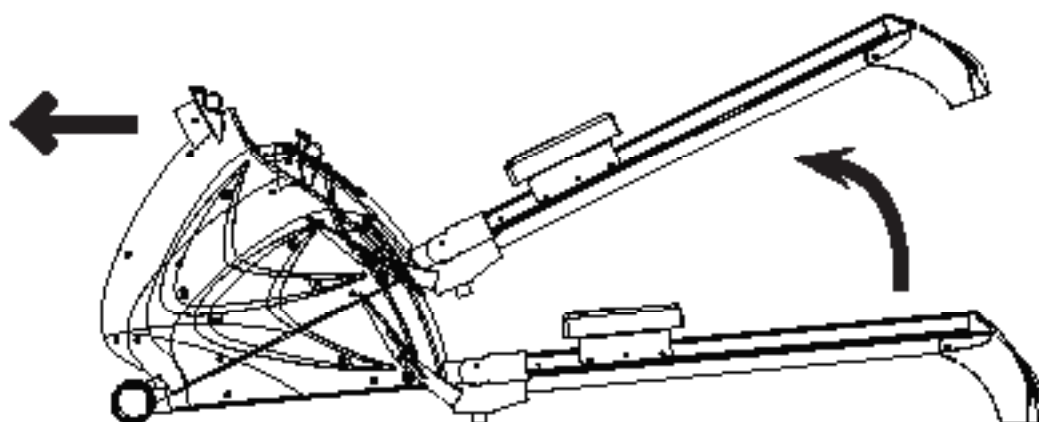

Console Layout and Design

Take a few moments to review the console layout. Below is an overview of the console and their different functions.

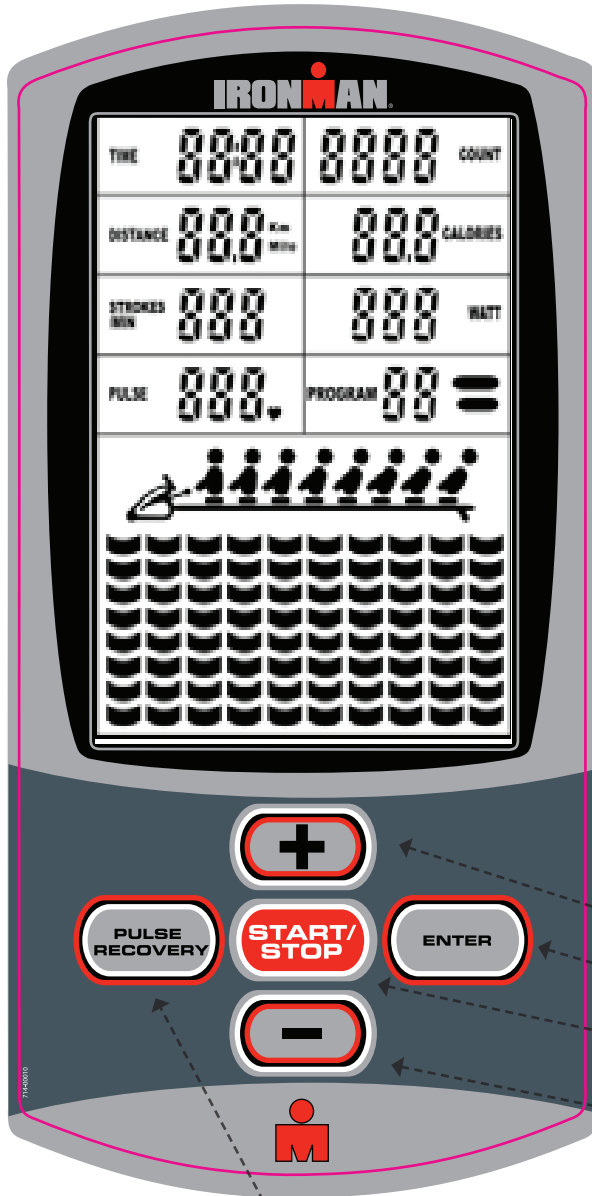

The miles / kilometer switch is located on the back of the console. To remove the console, push in the tab of the lower part of the console and lift up.

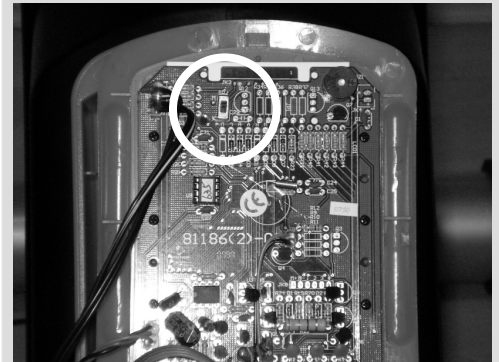

To change from miles to kilometers and vice versa, flip the switch highlighted inside the circle. Once switched, you must restart the console to activate.

- (d) Increase
- (c) Enter
- (b) Start/Stop
- (e) Decrease
- (a) Pulse Recovery

A. Powering Up:

1. Connect adapter into power source
2. If the connection cables were installed incorrectly, monitor will display "E1" on matrix display and will generate a long beeping sound. Before asking service, please examine if all connection cables are well connected and then reset the power to release the beep sound or press **START / STOP (Hold to reset)** button to restart system. If the monitor still show "E1" message, please call service.
3. If the monitor shows " E2 "message, please call service.

B. Button Functions:

Enter

This button is used to confirm desired settings into the console for function purposes.

- During PAUSE mode, press ENTER key to enter desired program.

Start/Stop

This button is used to start and stop training.

Recovery

This button is used to begin the recovery feature of the console (Heart rate chest strap must be worn to activate this feature.) When pressed, the recovery button will begin to check pulse from the monitoring system located in the chest strap.

F1.0 = Excellent F2.0 = Good F3.0 = Fair F4.0 = Below average
F5.0 = Not Good F6.0 = Poor

Up/Down

When changing settings of a program, these buttons are used to increase/decrease the value of any setting input, such as: TIME, WEIGHT, and AGE.

C. Console Functions:

TIME

Exercise time will be shown on the display when exercising. If there is no signal detected within 4 minutes the console will shut off.

Count up: Without setting the time value, the monitor will count up the time from 0:00 to 99:59.

Count down: Setting the exercise time, the monitor will count down from your set values. Once reach setting value, monitor will produce an audible sound. The time will stop and summary is shown on screen.

COUNT

Count will be shown on the display when exercising. If there is no signal detected within 4 minutes, the console shuts down.

Count up: Without setting the count value, the monitor will count up the count from 0 to 9999.

Count down: If exercise time is set, the monitor will count down from your set values. Once set value is reached, monitor will produce an audible sound.

CALORIE

The calories burned will be displayed on the window. It ranges from 0.0 to 999k cal.

Count up: Without setting the calorie value, the monitor will count up the count from 0.0 to 999.

Count down: If calorie consumption is set, the monitor will count down from your set values. Once set value is reached, monitor will produce an audible sound.

DISTANCE

The distance will be displayed on the window. The monitor begins to calculate from 1 yard to 999 yard and then the measure unit is 1 yard. After 1000 yards is reached, the measure unit becomes 0.6 mi (1000 yards). The monitor will display from 0.6 to 99.9 mi.

Count up: Without setting the distance value, the monitor will count up from 1 yard.

Once it reaches 1000 yards, it will convert to 0.6 miles.

Note: If the units are by kilometers the count up and down will be by meters into KM.

Count down: If distance is set, the monitor will count down from your set values. Once set value is reached, monitor will produce an audible sound, and then the count value starts counting up.

PULSE

The monitor will display your current heart beat rate in beats per minute. The pulse reading ranges are: Low (40 bpm) - High (220 bpm). If no pulse signal is detected within 16 seconds, the display will indicate "P" You can input a desired target heart rate - input value ranges from 90 to 220. Once your heart rate exceeds set target, the pulse window will blink to inform you that your heart rate has exceeded your target.



The picture indicates the travel distance on the rower machine during exercise.

D. Operation:

The console contains 12 different programs, which can be customized for total workout time. If you don't preset the workout time, the console will count up the workout time in one-second increment. Each program is divided into 10 segments. Workout time is evenly distributed in each of the 10 segment with the default set at 3 minutes if no total workout time is set. When total workout time is set, time counts down. Without setting the workout time, the time will count up and each interval will retain 3 minutes.

Preset Program: Program 1- Program 7

1. Press the **UP** or **DOWN** button to the desired program.
2. Press the **Enter** Button to enter your desired program.
3. The Time display will flash, and then press the **UP OR DOWN** button to set up the desired time to do the exercise. Press **ENTER** button to confirm your setting value.
4. The count display will flash, and then press the **UP OR DOWN** button to set up the desired value. Press **ENTER** button to confirm your setting value.
5. The distance display will flash, and then press the **UP OR DOWN** button to set up the desired distance you would like to reach. Press **ENTER** button to confirm your setting value.
6. The calorie display will flash, and then press the **UP OR DOWN** button to set up the desired calorie you would like to reach. Press **ENTER** button to confirm your setting value.
7. Press the **START/STOP** to begin exercise.

Note: *If you would like to skip the function setting, press the **ENTER** button to the next setting function.*

1. *When you reach the target, the monitor will produce a beeping sound and stop its operation. If you set up more than one target and you would like to reach next target, press start to exercise again.*

TARGET HEART RATE PROGRAM: (Program 8) (also refer to program profiles on pg. 13)

In this program, the console will adjust the level of loading according to the heart rate detected. For example, the level of loading may increase while the heart rate detected is lower than TARGET H. R. Also, the level of loading may decrease while the heart rate detected is higher than TARGET H. R. As a result, the user's heart rate will be adjusted to close the TARGET H.R. in the range of TARGET H.R. -5 and TARGET H.R. +5.

1. Press the **UP AND DOWN** button to program 8.

2. Press the **ENTER** button to enter your target heart rate program.
3. The pulse display will flash, and then press the **UP OR DOWN** button to set up the desired limit heart rate you would like to keep. Press **ENTER** button to confirm your setting value.
4. The Time display will flash, and then press the **UP OR DOWN** button to set up the desired time to do the exercise. Press **ENTER** button to confirm your setting value.
5. The count display will flash, and then press the **UP OR DOWN** button to set up the desired value. Press **ENTER** button to confirm your setting value.
6. The distance display will flash, and then press the **UP OR DOWN** button to set up the desired distance you would like to reach. Press **ENTER** button to confirm your setting value.
7. The calorie display will flash, and then press the **UP OR DOWN** button to set up the desired calorie you would like to reach. Press **ENTER** button to confirm your setting value.
8. Press the **START/STOP** button to begin exercise.

Note:

1. *You must set up the pulse value in this program, because it is a heart rate control program.*
2. *If you do not set the pulse value, the initial setting value is 90 bpm (heart beats per minute).*
3. *When you reach one of the targets such as Time, Count, Distance, and Calories, the monitor will produce a beep sound and then stop.*
4. *If you set up more than one target and you would like to reach next target, press **START/STOP** to exercise again.*

User Setting Program: U1 to U4

Users are free to edit the values in the order of TIME, COUNT, DISTANCE, CAL, and the level of loading in 10 intervals. The values and profiles will be stored in the memory after setup. Users may also change the ongoing loading in each interval by pressing up or down button, and they will not change the level of loading stored in the memory.

1. Press the **UP AND DOWN** button to the User setting program.
2. Press the **ENTER** button to enter this program.
3. The Time display will flash, and then press the **UP OR DOWN** button to set up the desired time to do the exercise. Press **ENTER** button to confirm your setting value.
4. The count display will flash, and then press the **UP OR DOWN** button to set up the desired value. Press **ENTER** button to confirm your setting value.
5. The distance display will flash, and then press the **UP OR DOWN** button to set up the desired distance you would like to reach. Press **ENTER** button to confirm your setting value.
6. The calorie display will flash, and then press the **UP OR DOWN** button to set up the desired calorie you would like to reach. Press **ENTER** button to confirm your setting value.
7. The first segment will flash, and then press the **UP OR DOWN** button to create your personal exercise profile.
8. Press the **ENTER** button to confirm your first segment of your exercise profile.
9. The second segment will flash, and then press the **UP OR DOWN** button to create your personal exercise profile.
10. Press the **ENTER** button to confirm your second segment of your exercise profile.
11. Follow the above descriptions to finish your personal exercise profile.
12. Press the **START/STOP** to begin exercise.

NOTE:

1. Your personal exercise profile will be stored in the memory of the monitor.
2. When you reach the one of the targets such as Time, Count, Distance, and Calories, the monitor will produce a beeping sound and then stop.
3. If you set up more than one target and you would like to reach next target, press

Program profiles

Program Profiles

1. Program 1 (Manual)

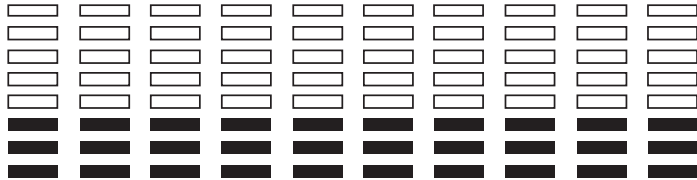

2. Program 2 (Rolling)

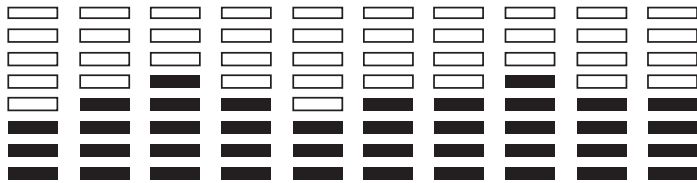

3. Program 3 (Valley)

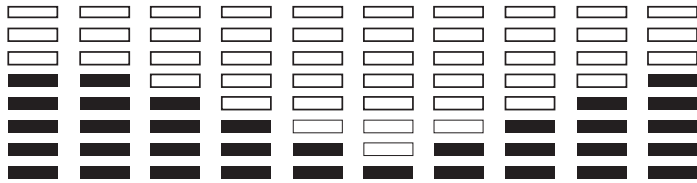

4. Program 4 (Fat Burn)

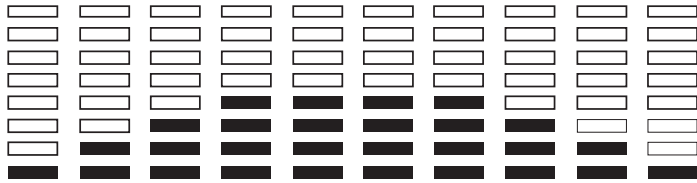

5. Program 5 (Ramp)

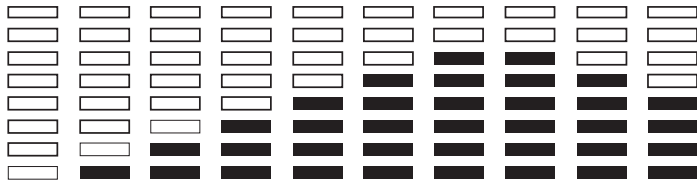

6. Program 6 (Manual)

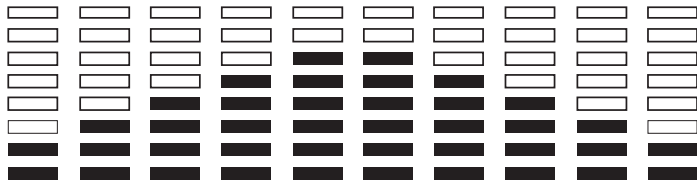

7. Program 7 (Intervals)

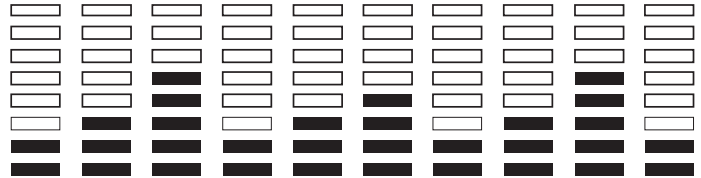

8. Program 8 (Mountain)

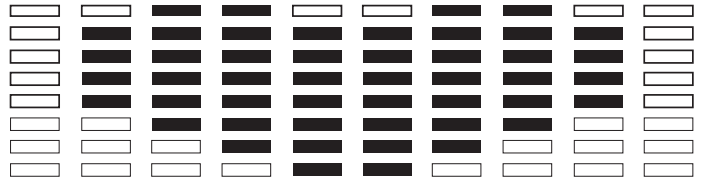

9. Program 9 (User setting)

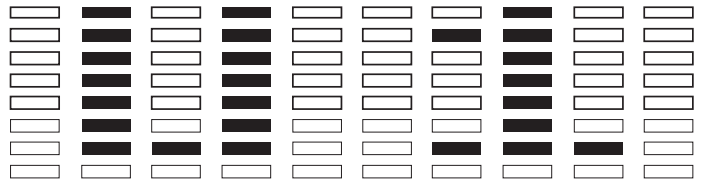

10. Program 10 (User setting)

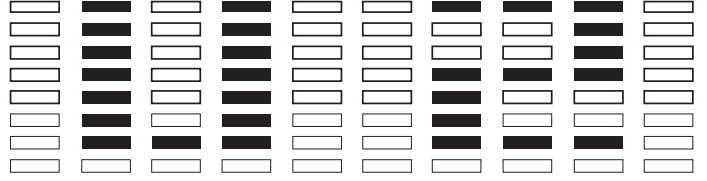

11. Program 11 (User setting)

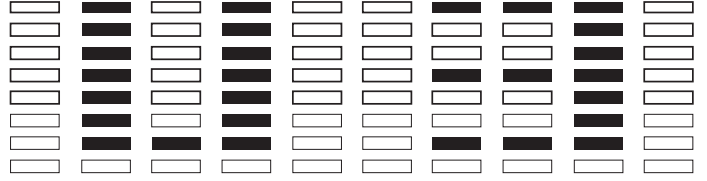

12. Program 12 (User setting)

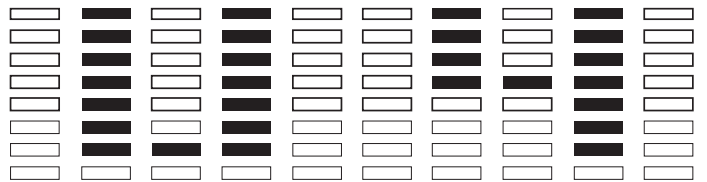

EXERCISE GUIDELINES

WARNING! Before beginning this or any exercise program, you should consult your physician. This is especially important for individuals over the age of 35 or individuals with pre-existing health problems.

Flexibility is a key to fitness. Stretch all major muscle groups at least two to three times per week after a 5 to 10 minute warmup. Stretch just to the point of a gentle tug. If you have back, joint, or other health problems, talk to your doctor first



Prone on Elbows

Lie on your stomach with your feet together. Rest on your forearms with your elbows directly under your shoulders. Relax lower back and abdomen into floor. Hold for 30-60 seconds or until muscles feel looser.



Supline Lumbar Rotation

Lie on your back with your knees bent. Keeping your knees together and your shoulders against the floor, roll your knees to one side until you feel a stretch in your back or hip. Hold for 30-60 seconds or until muscles feel looser. Repeat on opposite side.



Knees to Chest

Lie on your back. Bend your knees, and lift your feet off the floor. Grasp your knees with your arms and pull your knees toward your chest. Hold for 20 seconds. Repeat three to five times.



Cat and Camel

Rest on your hands and knees. Round your back by contracting your abdominal muscles and tucking in your pelvis; hold for five seconds. Then allow your back to sag toward the floor as you lift your chest and head; hold for five seconds. Repeat the combination 10 times



Cervical Side Bends

Tilt your head gently toward one shoulder, keeping your shoulders level and your face pointed straight ahead. Hold for five seconds, then tilt your head toward the other shoulder and hold for five seconds. Repeat five times on each side.



Shoulder Circles

In a smooth, continuous motion, make a circle with your shoulders: Raise them up towards your ears, pull them together behind you, lower them to a resting position, then roll them forward. Repeat 10 times.

WARNING! Before beginning this or any exercise program, you should consult your physician. This is especially important for individuals over the age of 35 or individuals with pre-existing health problems.

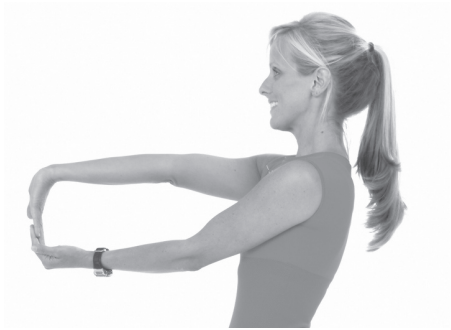

Wrist Extensor

Extend your right arm in front of you with your palm up and your elbow straight. Point your fingertips toward the floor by bending at the wrist. Using your left hand, pull the back of your right hand toward you gently. Hold for 20 seconds; repeat three to five times with each arm.



Wrist Flexor

Extend your right arm in front of you, palm down, elbow straight. Point your fingertips toward the floor by bending at the wrist. Using your left hand, pull your right palm toward you gently. Hold for 20 seconds; repeat three to five times with each arm.



Triceps Stretch

Place your right hand behind your head, palm facing your head. With your left hand, grasp your right elbow and pull downward until you feel a stretch in the back of your right arm. Hold for 20 seconds; repeat three to five times with each arm.



One-Arm Pectoralis Stretch

Stand against an immobile structure like a wall or a tree. While facing the wall, raise your right hand out to your side at chest height, palm against the wall. Turn your body toward the left, away from the wall and your extended arm, until you feel a stretch. Hold for 20 seconds; repeat three to five times with each arm.



Piriformis Stretch

Lie on your back. Bend your right knee and lift it halfway to your chest. Grasp your knee with your left hand and pull it toward your left shoulder, keeping both buttocks against the floor. Hold for 20 seconds; repeat three to five times with each leg.



Groin (Adductors) Stretch

Sitting with your back straight, bring the soles of your feet together. Let your knees lower toward the floor. Hold for 30-60 seconds or until muscles feel looser.

WARNING! Before beginning this or any exercise program, you should consult your physician. This is especially important for individuals over the age of 35 or individuals with pre-existing health problems.



Calf Stretch

Face a solid structure such as a wall with your left foot ahead of your right, toes straight ahead. Bend your left knee, press your hips forward, and lean into the wall. Keep both heels down, your right leg straight, and your left knee over your ankle. Hold for 20 seconds; repeat three to five times with each leg.



Standing Quadriceps Stretch

Steady yourself with one hand. With the other, grab outside leg at ankle, keeping body straight from knee to hip. Gently pull foot up and towards the buttocks until you feel a stretch along the front of the thigh. Thigh should be pulled straight back and not drift to outside. Hold 20-30 seconds. For variation, grab opposite ankle (i.e., grab right ankle with left hand). Do two to three repetitions per leg.



Achilles Stretch

Face the wall with your left foot ahead of your right, toes straight ahead. Bend both knees, press your hips forward, and lean into the wall. Keep both heels down and both knees in line with your feet. Hold for 20 seconds; repeat three to five times with each leg.

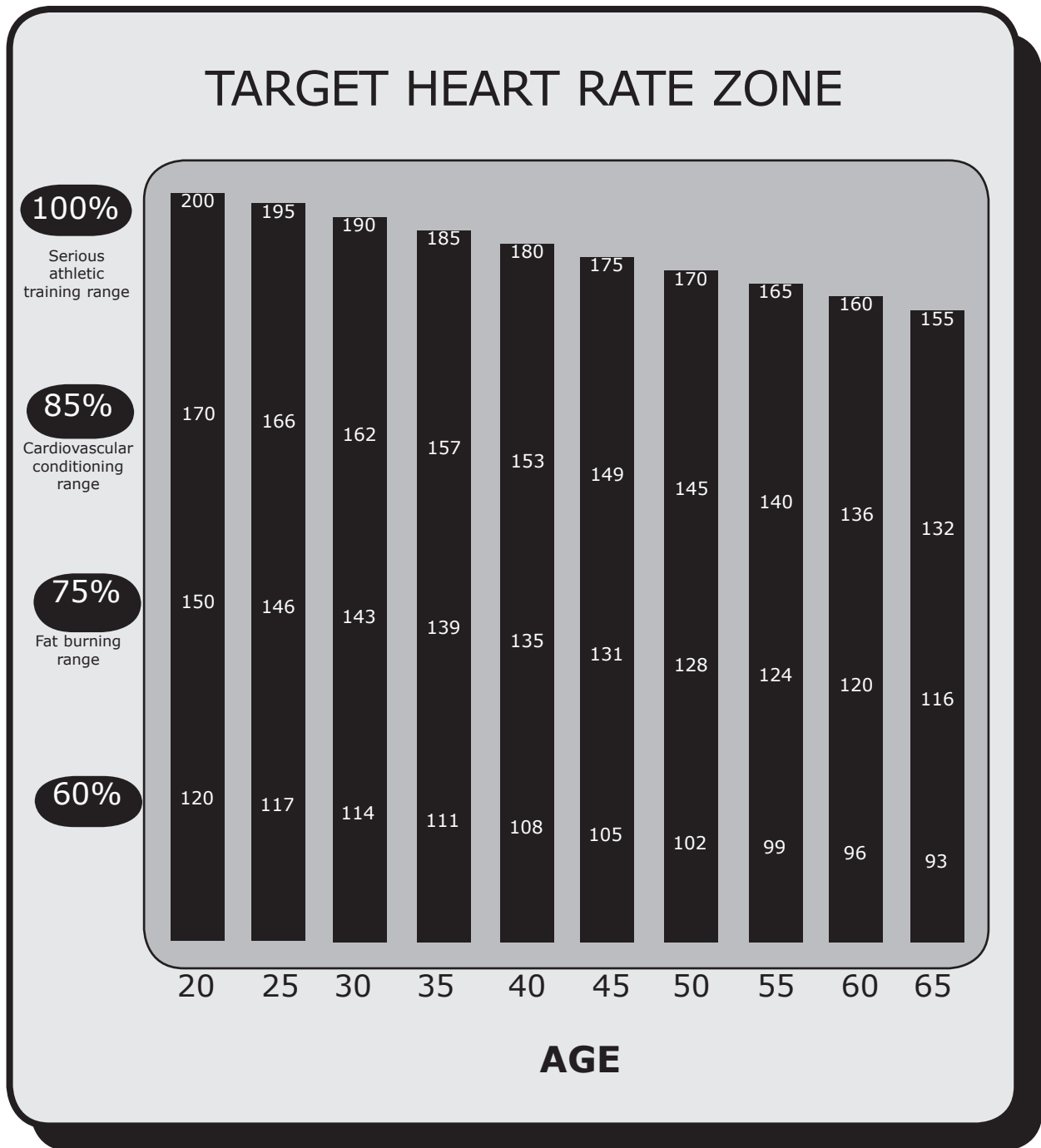

Monitoring Your Heart Rate

To obtain the greatest cardiovascular benefits from your exercise workout, it is important to work within your target heart rate zone. The American Heart Association (AHA) defines this target as 60%-75% percent of your maximum heart rate.

Your maximum heart rate may be roughly calculated by subtracting your age from 220. Your maximum heart rate and aerobic capacity naturally decreases as you age. This may vary from one person to another, but use this number to find your approximate effective target zone. For example, the maximum heart rate for an average 40 year-old is 180 bpm. The target heart rate zone is 60%-75% of 180 or 108-135 bpm.

See **Fitness Safety** on opposite page.

Before beginning your workout, check your normal resting heart rate. Place your fingers lightly against your neck, or against your wrist over the main artery. After finding your pulse, count the number of beats in 10 seconds. Multiply the number of beats by six to determine your pulse rate per minute. We recommend taking your heart rate at these times; at rest, after warming up, during your workout and two minutes into your cool down, to accurately track your progress as it relates to better fitness.

During your first several months of exercising, the AHA recommends aiming for the lower part of the target heart rate zone-60%, then gradually progressing up to 75%. According to the AHA, exercising above 75% of your maximum heart rate may be too strenuous unless you are in top physical condition. Exercising below 60% of your maximum will result in minimal cardiovascular conditioning.

Check your pulse recovery rate – If your pulse is over 100 bpm five minutes after you stop exercising, or if it's higher than normal the morning after exercising, your exertion may have been too strenuous for your current fitness level. Rest and reduce the intensity next time.

Fitness Safety *The target heart rate chart indicates average rate zones for different ages. A variety of different factors (including medication, emotional state, temperature and other conditions) can affect the target heart rate zone that is best for you. Your physician or health care professional can help you determine the exercise intensity that is appropriate for your age and condition.*

(MHR) = Maximum Heart Rate
(THR) = Target Heart Rate

$220 - \text{age} = \text{maximum heart rate (MHR)}$
 $\text{MHR} \times .60 = 60\% \text{ of your maximum heart rate.}$
 $\text{MHR} \times .75 = 75\% \text{ of your maximum heart rate.}$
For example, if you are 30 years old, your calculations will be as follows:

$220 - 30 = 190$
 $190 \times .60 = 114 \text{ (low end or 60\% of MHR)}$
 $190 \times .75 = 142 \text{ (high end or 75\% of MHR)}$
30 year-old (THR) Target Heart Rate would be 114-142

Frequency, Intensity, Time, Target Heart Rate Zone

The exercise practices include four major variables: frequency, intensity, time, target heart rate zone. A continuous workout will help to improve your cardiovascular functions and increase the ability of your muscles to obtain the oxygen and nutrition. A good workout provides a greater advantage to extend the endurance of muscle and body flexibility.

Frequency: How Often Should You Exercise

Three to five times a week is highly suggested to improve your cardiovascular and muscle fitness.

Intensity: How Hard Should You Exercise

The intensity of an exercise is reflected in your heart rate. Exercise must be sufficient to strengthen your heart muscle and condition your cardiovascular system. Only your doctor or an authorized coach can prescribe the target training heart range appropriate for your particular needs and physical condition.

Start with exercise that stimulates you to breathe more deeply. Alternate periods of moderate and easy exercise to help your body adapt to new levels of exertion without unnecessary strain. The inability to maintain a smooth, rhythmic motion is a sign that your speed or elevation is too high. If you feel out of breath before you have exercised 12 minutes, you are probably overdoing it.

As your fitness level improves, you will need to increase your workload to reach your target heart rate. The first increase may be necessary after two to four weeks of regular exercise. Never exceed your target heart rate zone.

Weight Management

Consistent aerobic exercise will help you change your body composition by lowering your percentage of body fat. For weight control, how long and how often you exercise is more important than how hard you exercise.

- ◆ Exercise at least four to five times a week.
- ◆ Reach and maintain 60-75% of your maximum heart rate with moderate exercise.
- ◆ Exercise for 30-45 minutes at 60-65% of your target heart rate.

Here are some tips to achieve your weight management goal.

- ◆ Consume most of your dietary calories at breakfast and lunch, and eat a light dinner.
- ◆ Do not eat anything near the bedtime.
- ◆ Moderate exercise will help suppress your appetite.
- ◆ Take regular breaks and rests to help increase metabolism.

Warning!

If you have any questions or concerns about your target heart rate consult your physician. Medications may affect your heart rate. Stop exercise if: you feel faint or dizzy, acute illness (cold or fever), any pain or tightness in your chest, an irregular heartbeat, or if you exceed your maximum heart rate set by your physician.

Exercise Practice Procedures

Warm-Up

Workout

Cool Down

A good warm-up will help you perform better and will decrease the aches and pains. The warm-up prepares your muscles for exercise and allows your oxygen supply to ready itself for what is to come. Experience tells us that muscles perform best when they are warmer than normal body temperature. This normally takes about 5-10 minutes when you begin to perspire on your brow and breathe more deeply.

Note: The older you are, the longer your warm-up period should be.

Workout: Brisk and Rhythmic Exercise

A workout trains your heart, lungs, and muscles to be more efficient. Increase exercise in response to your heart rate to train and strengthen your cardiovascular system. Concentrate on moving your arms and legs smoothly. Walking naturally and avoid jerking motions like pulled muscles, sprained joints, and loss of balance.

If you cannot sustain 12 continuous minutes in your target heart rate zone, then, exercise several times a day to get into habit. Try to reach and maintain 60-65% of your maximum heart rate. Alternate exercise with periods of rest until you can sustain 12 continuous minutes of exercise at 60-65% of your maximum heart rate. Best start with a target of 3-4 minutes, then, increase it gradually.

If you can sustain 12 but not 20 continuous minutes of exercise in your target heart rate zone:

- Exercise 3-5 days a week. Rest at least two days per week.
- Try to reach and maintain 65-70% of your maximum heart rate with moderate rhythmic exercises.
- Begin with 12 continuous minutes. Increase your time by one to two minutes per week until you can sustain 20 continuous minutes.

If you can sustain 20 minutes continuously in your target heart rate zone, begin to increase the length and intensity of your workout.

- Exercise 4-6 days a week or on alternate days.
- Try to reach and maintain 70~85% of your maximum heart rate with moderate to somewhat hard exercise.
- Exercise 20-30 minutes.

WARNING: These strategies are intended for average healthy adults. If you have pain or tightness in your chest, an irregular heartbeat, shortness of breath or you feel faint or have any discomfort when you exercise STOP. Consult your physician before continuing. Remember every workout should begin with warm-up and finished with cool-down.

Cool down: Slow and Relaxed Exercise

The cool-down allows your body's cardiovascular system to gradually return to normal and should be roughly 5-10 minutes. Lower your exercise intensity gradually, and when your heart rate has returned below 110 beats per minutes, you can end your workout.

SAFETY PRECAUTIONS AND TIPS FOR CHEST STRAP

1. It is the owner's responsibility to ensure that all users of this unit have read the Owner's Manual and are familiar with warnings and safety precautions.
2. Do not place chest strap near devices that generate large magnetic fields. TV sets, electric motors, radios, and high voltage power lines can affect the transmitter's performance. These items can interfere with the heart rate signal and possibly affect the heart rate readings on the console.
3. Handle the Chest Strap with care. Dropping the transmitter might cause damage that could void the warranty.
4. Do not use the chest strap if you have a cardiac pacemaker or if you are taking medications for a heart condition. Medication or electrical pulses from the pacemaker can interfere with accurate heart rate readings.
5. Do not bend the strips inside the chest strap. This can cause the chest strap to lose conductivity.
6. The chest strap has batteries that need to be replaced periodically. A faulty battery can cause inaccurate reading.

POWER OF 10 PART LIST REV A.

Ref #	Part #	Description	Qty	Ref #	Part #	Description	Qty
A2	723-00012	FRONT STABILIZER, POWER 10	1	3	702-00035	NUT 3/8*26, POWER 10	4
A3	719-00001	SLIDE TRACK (LOWER), POWER 10	1	4	702-00036	NUT 3/8 3T, POWER 10	1
A4	719-00002	SLIDE TRACK (UPPER), POWER 10	1	5	702-00037	SCREW M8*35L, POWER 10	3
A5	719-00003	PIVOT PLATE, POWER 10	1	6	702-00038	SCREW M8*30L, POWER 10	1
A6	723-00013	SEAT CARRIAGE, POWER 10	1	7	702-00039	TAPPING SCREW, 4*16, POWER 10	8
A7	719-00004	PULLEY, POWER 10	1	8	702-00040	M8 NUT, POWER 10	1
A8	702-00029	FIXING HOUSING, POWER 10	1	9	702-00041	NUT 3/8*4T,POWER 10	1
A9	707-00001	GEAR BOX, POWER 10	1	10	702-00042	SHAFT 1/2, POWER 10	4
B1	705-00001	SHROUD COVER (LEFT), POWER 10	1	11	702-00043	BOLT 3/8-120 L,POWER 10	1
B2	702-00030	END CAP 76, POWER 10	2	12	702-00044	NUT 3/8, POWER 10	1
B3	706-00030	PEDAL (LEFT), POWER 10	1	13	702-00045	BOLT 3/8*105L, POWER 10	1
B4	707-00002	CONSOLE, POWER 10	1	14	702-00046	NUT 3/8 7T, POWER 10	1
B5	706-00031	COVER, RUBBER, POWER 10	1	15	702-00047	BOLT M5*P0.8*15L, POWER 10	2
B6	706-00032	COVER, CONSOLE PLASTIC , POWER 10	1	16	702-00048	M6 NUT, POWER 10	2
B7	706-00036	COVER, REAR, POWER 10	1	17	702-00049	SCREW, M6*25L, POWER 10	2
B8	706-00033	FOOT CAP, POWER 10	1	18	702-00050	SCREW, M8*25L, POWER 10	4
C1	710-00007	KNOB CONNECTER, POWER 10	1	19	702-00051	BOLT M8*25L, POWER 10	6
C2	710-00004	POP PIN, POWER 10	1	20	702-00052	PIPE 12.5*8.2*10L, POWER 10	6
C3	719-00005	PU WHEEL 37, POWER 10	1	21	702-00053	M8 NUT, POWER 10	6
C4	710-00006	LEVELER, POWER 10	1	22	702-00054	BOLT 3/8*90L, POWER 10	1
C5	713-00001	HRC WIRE, POWER 10	1	23	702-00055	NUT 3/8, POWER 10	1
C9	702-00031	END CAP, POWER 10	2	24	702-00056	SCREW M8*40L, POWER 10	1
D1	710-00005	PLASTIC PULLEY, POWER 10	3	25	702-00057	SCREW M8*12L, POWER 10	4
D2	706-00034	HAND GRIP, POWER 10	1	26	713-00003	ADAPTOR, POWER 10	1
D3	706-00035	RUBBER STOPPER, POWER 10	2	*	702-00058	WASHER, POWER OF 10	2
D5	711-00001	MAGNETIC FLYWHEEL, POWER 10	1	*	705-00002	SHROUD COVER (RIGHT), POWER OF 10	1
D6	702-00032	SPRING FOR IDLE PULLEY, POWER 10	1	*	705-00003	CONSOLE COVER, POWER OF 10	1
D7	713-00002	SENSOR WIRE, POWER 10	1	*	706-00037	PEDAL, (RIGHT), POWER OF 10	1
D8	713-00004	EKG EXTENSION CABLE, POWER 10	1	*	706-00038	PEDAL STRAP, POWER OF 10	2
1	702-00033	CARRIAGE BOLT M8*90L, POWER 10	2	*	713-00005	DC POWER WIRE, POWER OF 10	1
2	702-00034	M8 NUT, POWER 10	2	*	713-00006	EXT. WIRE, GEAR BOX & CONSOLE, POWER 10	1

Exploded View

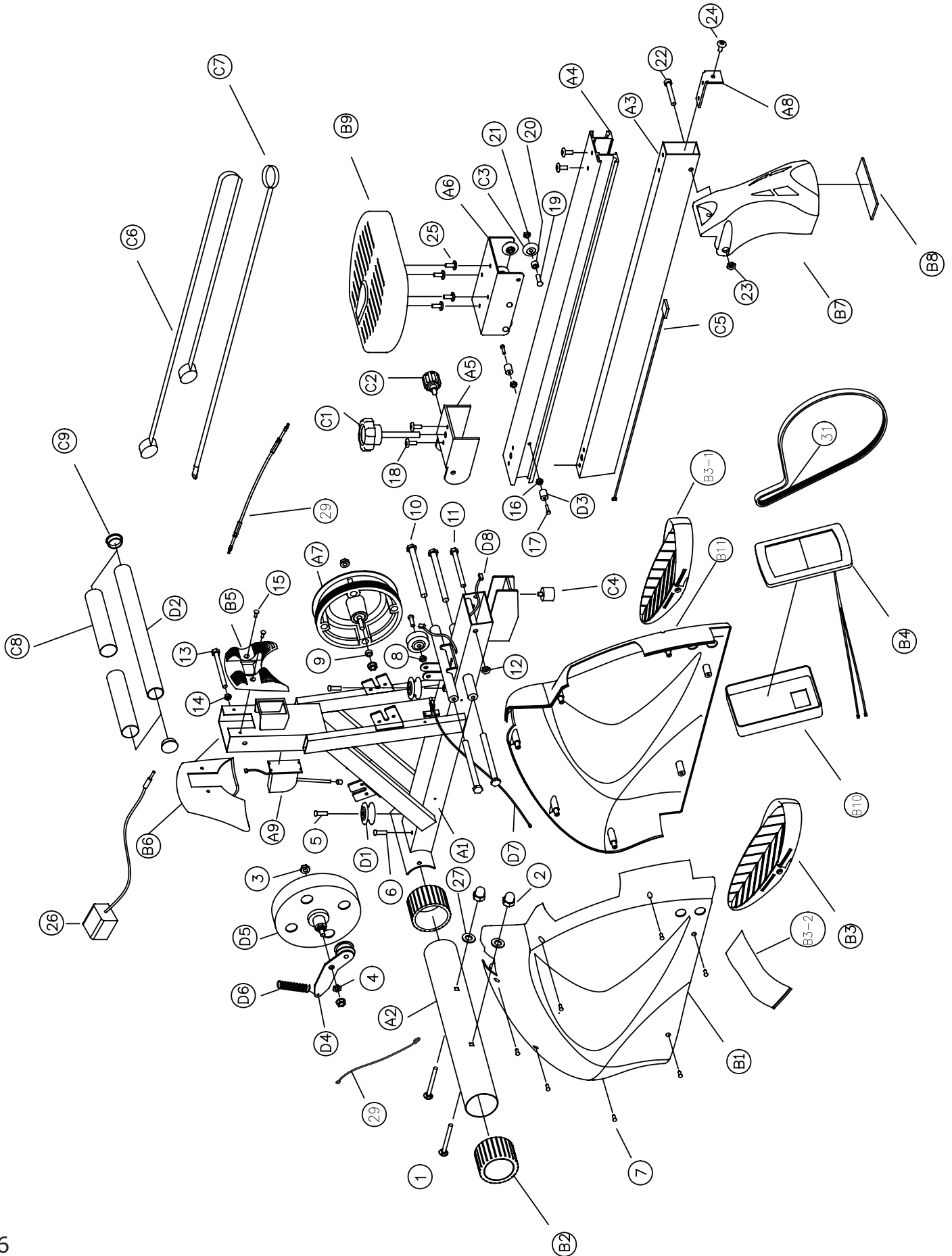



Residential and Personal Use Limited Warranty

PLEASE READ THESE WARRANTY TERMS AND CONDITIONS FULLY AND CAREFULLY BEFORE USING YOUR IRONMAN FITNESS EQUIPMENT. BY USING THE EQUIPMENT, YOU ARE CONSENTING TO BE BOUND BY THE FOLLOWING TERMS AND CONDITIONS.

Frame: Lifetime Parts: 1 yr Labor: 1 yr Missing/Cosmetic Parts: 30 Days

Limited Warranty

This Limited Warranty applies in the United States and Canada to Products manufactured or distributed by Ironman Fitness Products, L.P. under the Ironman Fitness ("Ironman Fitness") brand name (as used herein, the "Product" or "Products"). The warranty period to the original purchaser is listed above, and commences on the date of original purchase of the product, unless otherwise authorized by Ironman Fitness. Ironman Fitness warrants that the Product purchased from Ironman Fitness or from an authorized Ironman Fitness reseller "dealer" (for residential or personal use only, unless otherwise authorized by Ironman Fitness in writing), is free from defects in Materials and Workmanship relevant to the functionality of the Product at *initial startup*, under normal use, and during the applicable warranty period, unless otherwise determined by Ironman Fitness.

This warranty excludes *expendable parts* if primary cause for warranty claim is wear. *Expendable parts* pertain to components on the Product that are prone to normal wear and tear. These items vary by Product, and can include (but not limited to) hand grips, kick pads, pedals, pedal straps, poly-v belts, console overlays, toggle switch/button overlays, (luster free or dull) ekg plates, decals, and any other items that are not essential to the operation of the Product, unless otherwise determined by Ironman Fitness.

This warranty extends only to you, the original purchaser. It is not transferable to anyone who subsequently purchases (or receives as gift) the Product from you. Your sales receipt, showing the date/place of purchase and serial number (if applicable) of the Product, is your proof of purchase, and may be required by Ironman Fitness any time a warranty parts (or service) claim is made or if no warranty record exists for the product.

Exclusive Remedies

During the warranty period listed above, Ironman Fitness will repair a Product by correcting any minor issues (either by phone or online support) that might be causing the Product failure. Should a technical service and support representative be unable to correct the issue, Ironman Fitness may replace the parts (with new parts or at the option of Ironman Fitness, with serviceable used parts, that are equivalent to new parts in performance) that become defective, malfunction, or otherwise fail to conform to this Limited Warranty under normal use.

Replacement parts shall be warranted for 30 days from the shipment reception date or through the end of the 'replaced' part warranty period, whichever is longer. Any replacement parts, required *past the warranty period* listed above, shall be subject to purchase at retail price, plus any added shipping and handling charges associated to the delivery of the part. Note that replacement parts may be available only through the lifetime (as defined) of the Product. In conforming to this warranty, Ironman Fitness (as the manufacturer) reserves the right to change manufacturers or vendors of any part to cover the existing warranty.

Ironman Fitness may also provide service (if deemed necessary and if applicable) at no charge to you during (and not to exceed) the service warranty period listed above, in an attempt to repair the Product. Should the Product require service at your request or out of the limited warranty period, Ironman Fitness can furnish contact information for local (to your area) Ironman Fitness authorized service providers. Service quotes, costs, and scheduling will be strictly dependent on service provider rates and mutual (consumer/provider) service agreements. Ironman Fitness is not responsible for any service repair costs accrued through the use of authorized Ironman Fitness service providers at your request or out of the limited warranty period (without written consent from Ironman Fitness), beyond the limitations outlined on this warranty.

Replacements and Returns

If after a reasonable number of attempts, a defect has not been repaired (or the Product is deemed non-repairable by Ironman Fitness technical service and support staff), Ironman Fitness, based on a case by case review, may opt to replace the Product, or recommend an alternate resolution, such as a warranty buy-out (Product cost, subject to deduction of a reasonable charge for usage) or a credit. Ironman Fitness, as a manufacturer, reserves the right to replace the Product with a Factory-Reconditioned Product that meets or exceeds standards comparable to those of the replaced Product.

The warranty covering the replacement Product shall expire on the date the original warranty for the replaced Product would have expired, unless otherwise determined by Ironman Fitness.

Conditions and Restrictions

This warranty **DOES NOT** (A) cover shipping and handling charges, export taxes, custom duties and taxes, or any other charges associated with transportation of the parts or Product, beyond the initial courtesy period of 60 days from original date of purchase of the Product; (B) extend to Products not purchased from Ironman Fitness or from an authorized Ironman Fitness reseller; (C) extend to Products purchased from online auction sites; (D) cover any extended, additional, or third party warranties if not offered exclusively by Ironman Fitness in writing; (E) cover Products installed at fee based facilities/commercial environments (gyms, homes used as wellness centers, etc.); (F) cover Products installed in light institutional environments (non fee-based facilities include for example, and not be way of limitation, fire houses, police departments, rehab centers, hospitals, clinics, apartment complexes, club houses, etc.); (G) cover service calls to correct installation, perform maintenance, or instruct owners on how to use the equipment; or (H) cover a Product on which the serial number has been purposefully or accidentally defaced or removed and there is no proof of purchase available (if serial number is applicable), unless authorized by Ironman Fitness in writing or otherwise stated on this warranty.

This Limited Warranty becomes void for Products that have been damaged or rendered defective as a result of (a) accident, misuse, or abuse (including but not limited to exceeding the Ironman Fitness listed, maximum weight limit); (b) use of parts not manufactured or sold by Ironman Fitness; (c) modification of the Product; (d) normal wear and tear; (e) operation on incorrect power supplies; (f) ***failure to perform (or performing improper) maintenance; (g) service by anyone other than Ironman Fitness, or an authorized Ironman Fitness warranty service provider; (h) floods, fires, earthquakes, lightning strikes, power surges, and other unavoidable acts of nature; (j) residential mis-wires; or (k) incorrect setup, installation, or assembly. Should any Product (submitted for warranty parts replacement) be found ineligible under the terms outlined on this warranty, an estimate for parts purchase (if available) can be furnished at your request.

***Parts** is herein defined exclusively, for all intents and purposes, and pertaining to this Limited Manufacturer Warranty, as components or Materials essential to the functionality of the Product.

****Lifetime** of a Product, is herein defined exclusively, for all intents and purposes, and pertaining to this Limited Manufacturer Warranty, as the time period 7 years beyond the end of production cycle of a Product in question.

Disclaimer and Release

EXCEPT AS EXPRESSLY SET FORTH IN THIS WARRANTY, IRONMAN FITNESS MAKES NO OTHER WARRANTIES, EXPRESSED OR IMPLIED, INCLUDING ANY IMPLIED WARRANTIES OF MERCHANTABILITY AND FITNESS FOR A PARTICULAR PURPOSE. IRONMAN FITNESS EXPRESSLY DISCLAIMS ALL WARRANTIES NOT STATED IN THIS LIMITED WARRANTY. ANY IMPLIED WARRANTIES THAT MAY BE IMPOSED BY LAW ARE LIMITED TO THE TERMS OF THIS LIMITED WARRANTY. NEITHER IRONMAN FITNESS NOR ANY OF ITS AFFILIATES SHALL BE RESPONSIBLE FOR INCIDENTAL OR CONSEQUENTIAL DAMAGES. SOME STATES DO NOT ALLOW LIMITATIONS ON IMPLIED WARRANTIES OR THE EXCLUSION OR LIMITATION OF INCIDENTAL OR CONSEQUENTIAL DAMAGES, SO THE ABOVE LIMITATIONS OR EXCLUSIONS MAY NOT APPLY TO YOU. THIS LIMITED WARRANTY GIVES YOU SPECIFIC LEGAL RIGHTS AND YOU MAY ALSO HAVE OTHER RIGHTS THAT MAY VARY FROM STATE TO STATE. THIS IS THE ONLY EXPRESS WARRANTY APPLICABLE TO IRONMAN FITNESS-BRANDED PRODUCTS. IRONMAN FITNESS NEITHER ASSUMES NOR AUTHORIZES ANYONE TO ASSUME FOR IT ANY OTHER EXPRESS WARRANTY.



IRONMAN[®]

POWER 10

Customer Service
(800) 750-4766
Assembly
(888) 559-8810

Manufactured by:
Ironman Fitness Products
4009 Distribution Drive
Suite 250
Garland, TX 75041

www.ironmanfitness.com

IRONMAN, IRONMAN TRIATHLON and M-DOT are registered trademarks of the World Triathlon Corporation.
This product is licensed by the Ironman Triathlon.