

# Hoshizaki America, Inc.

Ice and Water Dispenser

Model  
DM-200B



“A Superior Degree  
of Reliability”

[www.hoshizaki.com](http://www.hoshizaki.com)

## SERVICE MANUAL



Number: 73142  
Issued: 8-24-2006

**IMPORTANT**

Only qualified service technicians should attempt to install, service or maintain this product. No installation, service or maintenance should be undertaken until the technician has thoroughly read this Service Manual.

HOSHIZAKI provides this manual primarily to assist qualified service technicians in the service and maintenance of this product.

Should the reader have any questions or concerns which have not been satisfactorily addressed, please call, write or send an e-mail message to the HOSHIZAKI Technical Support Department.

HOSHIZAKI AMERICA, INC.  
618 Highway 74 South  
Peachtree City, GA 30269

Attn: HOSHIZAKI Technical Support Department

Phone: 1-800-233-1940 Technical Service  
(770) 487-2331

Fax: 1-800-843-1056  
(770) 487-3360

E-mail: [technicalsupport@hoshizaki.com](mailto:technicalsupport@hoshizaki.com)

Web Site: [www.hoshizaki.com](http://www.hoshizaki.com)

**NOTE:** To expedite assistance, all correspondence/communication **MUST** include the following information:

- Model Number
- Serial Number
- Complete and detailed explanation of the problem

Please review this manual. It should be read carefully before this product is serviced or maintenance operations are performed. Only qualified service technicians should service and maintain this product. This manual should be made available to the technician prior to service or maintenance.

## CONTENTS

I. Specifications.....	4
II. General Information .....	5
A. Construction.....	5
III. Technical Information .....	6
A. Wiring Diagram .....	6
IV. Service Diagnosis.....	7
V. Removal and Replacement of Components .....	9
A. Removal and Replacement of Gear Motor.....	9
B. Removal and Replacement of Solenoid.....	10
C. Removal and Replacement of Water Valve.....	10
VI. Cleaning and Maintenance Instructions .....	11
A. Cleaning.....	11
1. Cleaning Procedure.....	11
2. Sanitizing Procedure - Following Cleaning Procedure .....	11
B. Maintenance – Exterior Panels .....	13
C. Preparing the Dispenser for Long Storage .....	13

---

## I. Specifications

### A. DM-200B

---

AC SUPPLY VOLTAGE	115/60/1
AMPERAGE	1.4 A
MINIMUM CIRCUIT AMPACITY	15 A
MAXIMUM FUSE SIZE	15 A
APPROXIMATE ELECTRIC CONSUMPTION	110 W

---

APPROXIMATE STORAGE CAPACITY      200 lbs (91 Kg)

APPROXIMATE ICE DISPENSING SPEED      7.5 lbs/min    (6 kg/min)

---

EXTERIOR DIMENSIONS ( W x D x H )	30" x 28" x 36.4"	(762 x 711 x 925 mm)	Without 4" Legs
INTERIOR DIMENSIONS ( W x D x H )	23.3" x 22.4" x 22.5"	(592 x 569.5 x 571 mm)	
EXTERIOR FINISH	Stainless Steel		
INTERIOR FINISH	Galvanized Steel Rear Panel		
INSULATION	Polyethelene 1 pc. Mold		
WEIGHT	Net 207 lbs (94 kg), Shipping 240 lbs (109 kg)		
CONNECTIONS - ELECTRIC	Power Cord		
- DRAIN	Outlet 3/4" FPT		
- WATER SUPPLY	Inlet 1/2" FPT		

---

GEAR MOTOR	60 W
AGITATOR	Stainless Steel Round Bar 14.5" Dia.

---

GEAR MOTOR PROTECTION      Thermal Protector (Internal)

---

ACCESSORIES - OPTIONAL      4" Legs, 4 pcs

---

OPERATING CONDITIONS	VOLTAGE RANGE	104 - 132 V
	AMBIENT TEMP.	45 - 100° F
	WATER SUPPLY TEMP.	45-90°F
	WATER SUPPLY PRESSURE	10-113 PSIG

---

Note: We reserve the right to make changes in specifications and design without prior notice.

---

## II. General Information

### A. Construction

#### 1. DM-200B

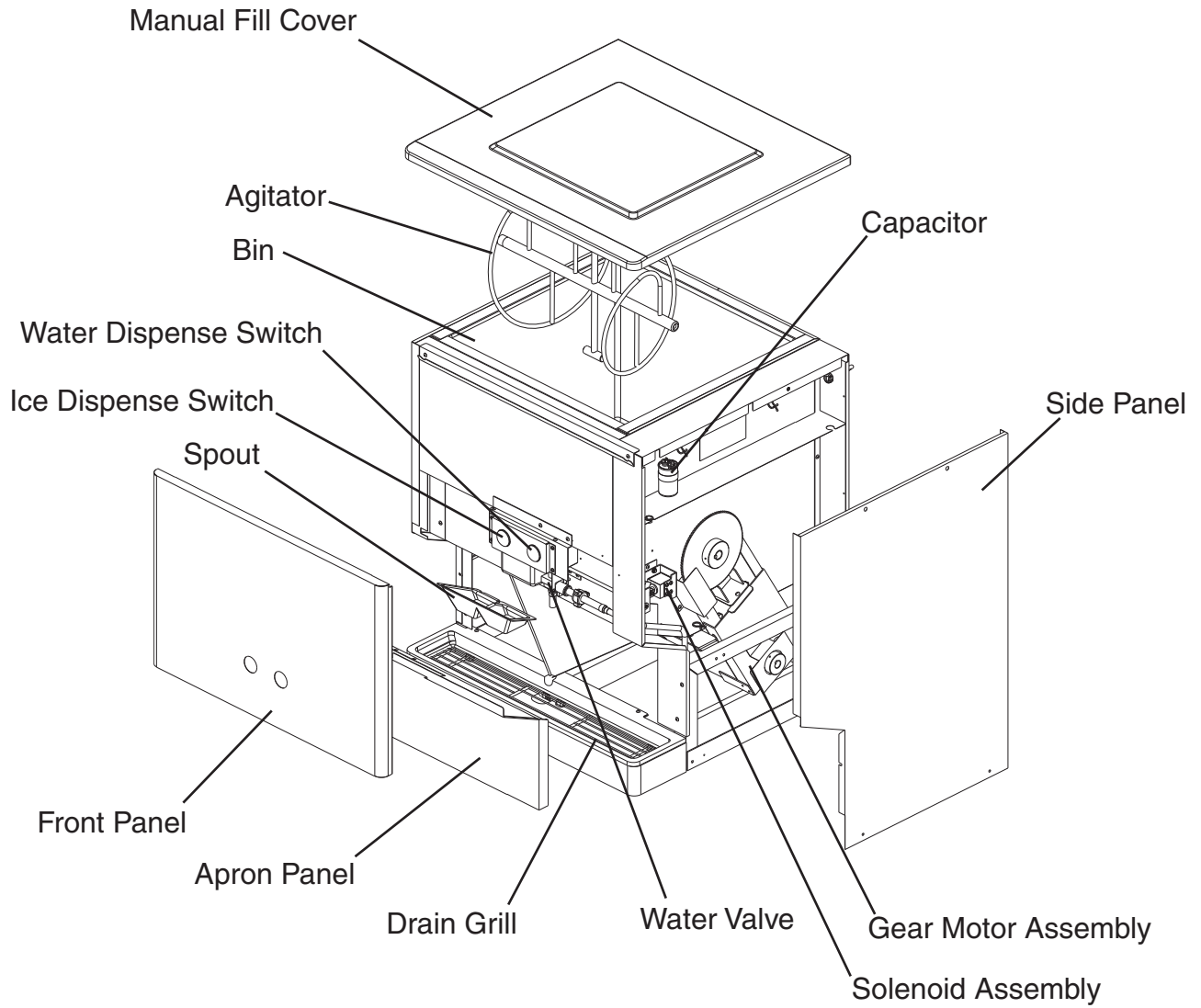

### III. Technical Information

#### A. Wiring Diagram

##### 1. DM-200B

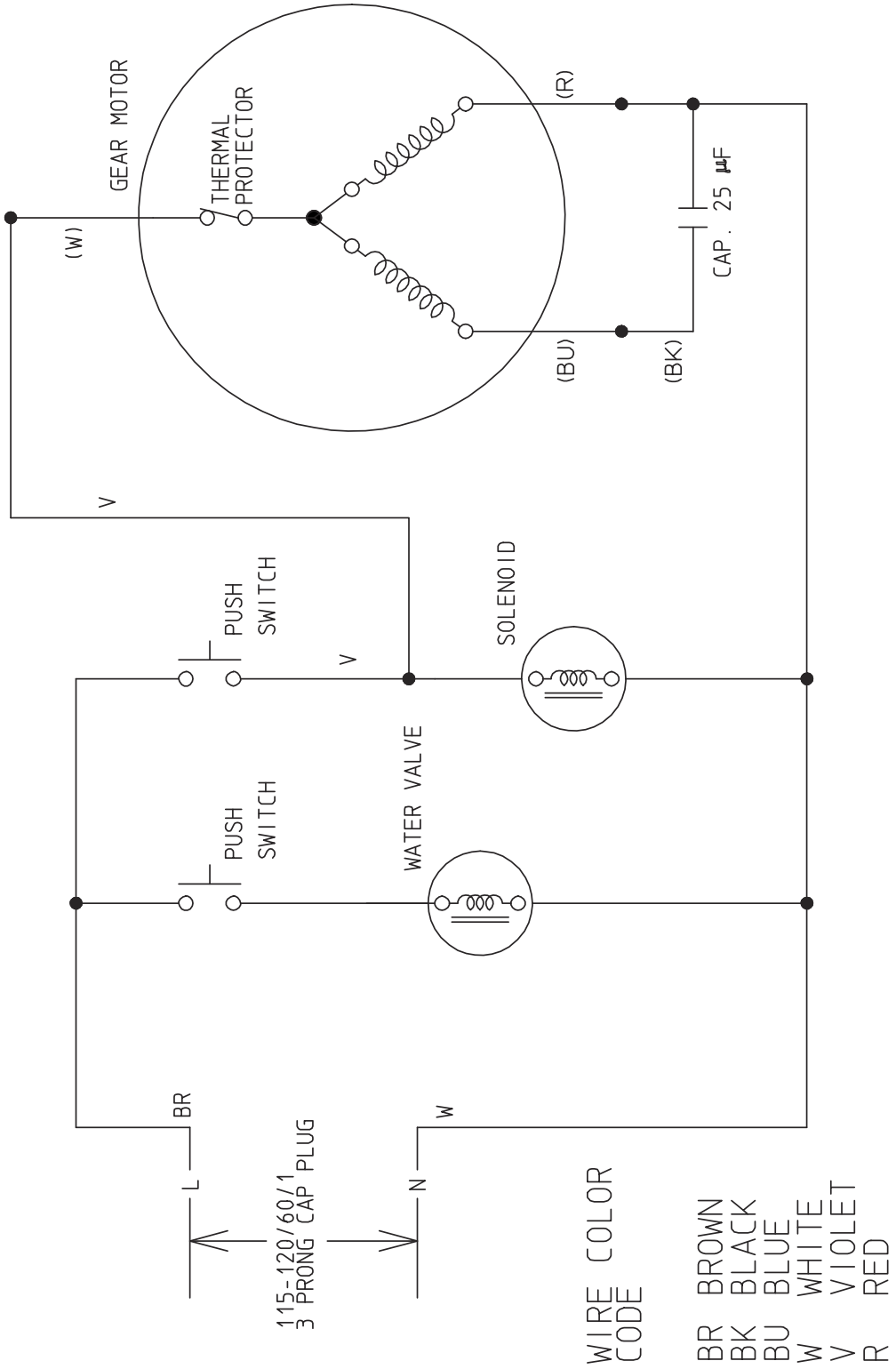

## IV. Service Diagnosis

Problem	Possible Cause	Remedy	
[1] No ice dispensed.	a) Power Supply	1. Off at breaker or cord unplugged.	1. Turn on or plug in cord.
		2. Loose connection.	2. Tighten.
		3. Bad contacts.	3. Check for continuity and replace.
	b) Dispense Switch	1. Bad contacts.	1. Check for continuity and replace.
		2. Loose connection.	2. Tighten.
	c) Gear Motor	1. Thermal protector is tripped.	1. Allow to cool.
		2. Gear motor winding opened.	2. Replace.
		3. Bearing worn out.	3. Replace.
		4. Wiring to gear motor.	4. Check for loose connection or open circuit, and replace wiring as needed.
		5. Defective capacitor.	5. Replace.
		6. Agitator rotates in reverse direction.	6. Check leads and reverse the connections.
	d) Solenoid	1. Solenoid winding open.	1. Replace.
		2. Wiring to solenoid.	2. Check for loose connection or open circuit, and replace wiring as needed.
		3. Overload due to loosening screws.	3. After tightening, apply thread sealant to the parts.
	e) Mechanism	1. Chain out of position or loose.	1. Place in position or tighten.
		2. Corrosion.	2. Apply oil.
		3. Key of sprocket is not in position.	3. Place in position.
		4. Bad alignment of sprocket.	4. Readjust.
5. Foreign matter interrupting agitator.		5. Remove foreign matter.	
f) Ice Storage	1. No ice or little ice in storage bin.	1. Fill bin with ice.	
	2. Ice bridge or block formed.	2. Break with a poker.	
[2] No water dispensed.	a) Power Supply	1. Off at breaker or cord unplugged.	1. Turn on or plug in cord.
		2. Loose connection.	2. Tighten.

<b>Problem</b>	<b>Possible Cause</b>		<b>Remedy</b>
		3. Bad contacts.	3. Check for continuity and replace.
	b) Water Supply	1. Off or disconnected.	1. Turn on or connect.
	c) Dispense Switch	1. Bad contacts.	1. Check for continuity and replace.
		2. Loose connection.	2. Tighten.
[3] Abnormal noise.	a) Gear Motor or Gear Head	1. Bearing worn out.	1. Replace.
		2. Grease leaks.	2. Supply grease and replace O-ring.
	b) Mechanism	1. Bad setting.	1. Apply oil and readjust.
		2. Bad alignment of sprocket.	2. Readjust.
		3. Foreign matter interrupting agitator.	3. Remove foreign matter.
	c) Solenoid	1. Overload due to loosening screws.	1. After tightening, apply thread sealant to the parts.
2. Foreign matter on plunger.		2. Clean.	
[4] Ice supply in storage bin often melts.	a) Bin Drain	1. Clogged.	2. Unclog.



## V. Removal and Replacement of Components

### IMPORTANT

Ensure all components, fasteners and thumbscrews are securely in place after the equipment is serviced.

### A. Removal and Replacement of Gear Motor

- 1) Unplug the unit from the electrical outlet.
- 2) Remove the panels.
- 3) Disconnect the gear motor wiring harness.
- 4) Loosen the adjustment bolt, then loosen the four bolts securing Gear Motor Bracket (B).
- 5) Slide Gear Motor Bracket (B) up to its highest position and retighten.
- 6) Remove the chain.
- 7) Loosen the socket set screw securing the sprocket, then use a gear puller to remove the sprocket.
- 8) Remove the bushing from the barrier and slide the gear motor wires free of the barrier. Release the wires from the wire tie on the barrier.
- 9) While supporting the gear motor and barrier, remove the four bolts securing them to Gear Motor Bracket (B). Carefully remove the motor and barrier.
- 10) Install the new gear motor, assembling the removed parts in the reverse order of the above procedure.  
Note:
  - When weight (2.2 lb) is applied to the chain at the center, the displacement must be 0.31 to 0.51".
  - Lubricant (Class SAE 20) must be applied to the chain using a cloth.
- 11) Replace the panels in their correct positions.
- 12) Plug the unit back in.

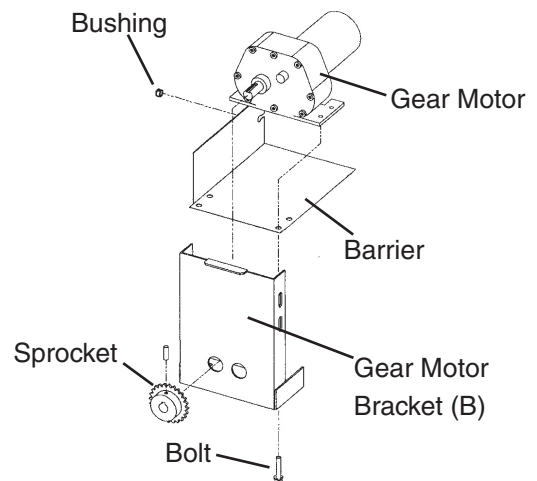
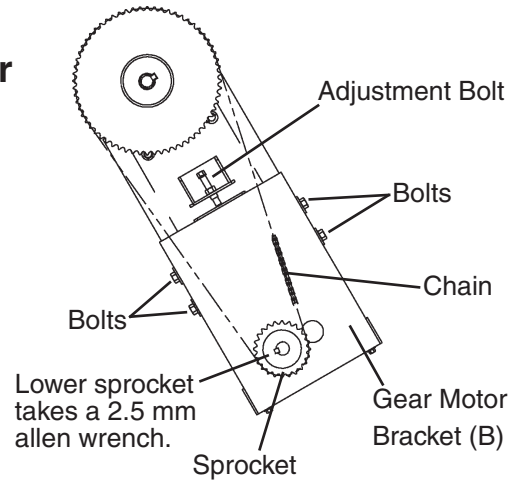

## **B. Removal and Replacement of Solenoid**

- 1) Unplug the unit from the electrical outlet.
- 2) Remove the panels.
- 3) Disconnect the connectors from the solenoid leads.
- 4) Remove the solenoid, and install a new solenoid.
- 5) Connect the connectors to the solenoid leads.
- 6) Replace the panels in their correct positions.
- 7) Plug the unit back in.

## **C. Removal and Replacement of Water Valve**

- 1) Unplug the unit from the electrical outlet.
- 2) Close the water supply line shut-off valve.
- 3) Remove the panels.
- 4) Loosen the fitting nut. Be careful not to lose the washer.
- 5) Disconnect the terminals from the water valve.
- 6) Remove the screws attaching the valve bracket to the machine wall, then remove the bracket and valve from the unit.
- 7) Remove the valve from the bracket.
- 8) Attach the short dispense hose and hose clamp to the new water valve (reuse the ones from the previous valve or install new).
- 9) Install the new water valve, and replace the removed parts in the reverse order of which they were removed. Make sure the washer is in place in the fitting nut.
- 10) Open the water supply line shut-off valve.
- 11) Plug the unit back in.
- 12) Check for leaks.
- 13) Replace the panels in their correct positions.

---

## VI. Cleaning and Maintenance Instructions

### IMPORTANT

Ensure all components, fasteners and thumbscrews are securely in place after any maintenance or cleaning is done to the equipment.

### A. Cleaning

#### WARNING

1. Hoshizaki recommends cleaning this unit at least once a year. More frequent cleaning, however, may be required in some existing water conditions.
2. To promote safety, always unplug the unit from the electrical outlet before any cleaning and maintenance procedures are started.
3. To prevent injury to individuals and damage to the dispenser, do not use ammonia type cleaners.
4. Always wear liquid-proof gloves to prevent the cleaning and sanitizing solutions from coming into contact with skin.
5. For safety and maximum effectiveness, use cleaning and sanitizing solutions immediately after dilution.

#### 1. Cleaning Procedure

- 1) Remove all ice from the ice dispensing bin.
- 2) Unplug the unit from the electrical outlet.
- 3) Remove the cover.
- 4) Remove the front panel. See Fig. 1.
- 5) Loosen the thumbscrews securing the apron panel and spout, then slide the spout out from the front. Next, remove the thumbscrews and the apron panel.
- 6) Remove the snap pin securing the shutter assembly. Slide the shutter shaft to the left, pull out the right side and slide out.
- 7) Dilute 5 fl. oz. (148 ml) of recommended cleaner Hoshizaki "Scale Away" or "LIME-A-WAY," (Economics Laboratory, Inc.) with 1 gallon (3.8 l) of warm water.
- 8) Scrub the cover, spout, apron panel, shutter assembly, agitator, and the inside of the bin using a nylon scouring pad, brushes and cleaning solution.
- 9) Rinse all parts from step 8 thoroughly with water.

#### 2. Sanitizing Procedure - Following Cleaning Procedure

- 1) Dilute approximately 0.5 fl. oz. (15 ml or 1 tbs) of a 5.25% sodium hypochlorite solution (chlorine bleach) with 1 gallon (3.8 l) of warm water.
- 2) Soak the removed parts from step 8 above in a clean container containing the sanitizing solution. After allowing the parts to soak for 10 minutes, wash them with the solution. Also wash the bin and agitator with the solution.
- 3) Rinse all parts from step 2 thoroughly with water.
- 4) Reassemble the removed parts in the reverse order of removal.
- 5) Plug the unit back in and check for proper operation.

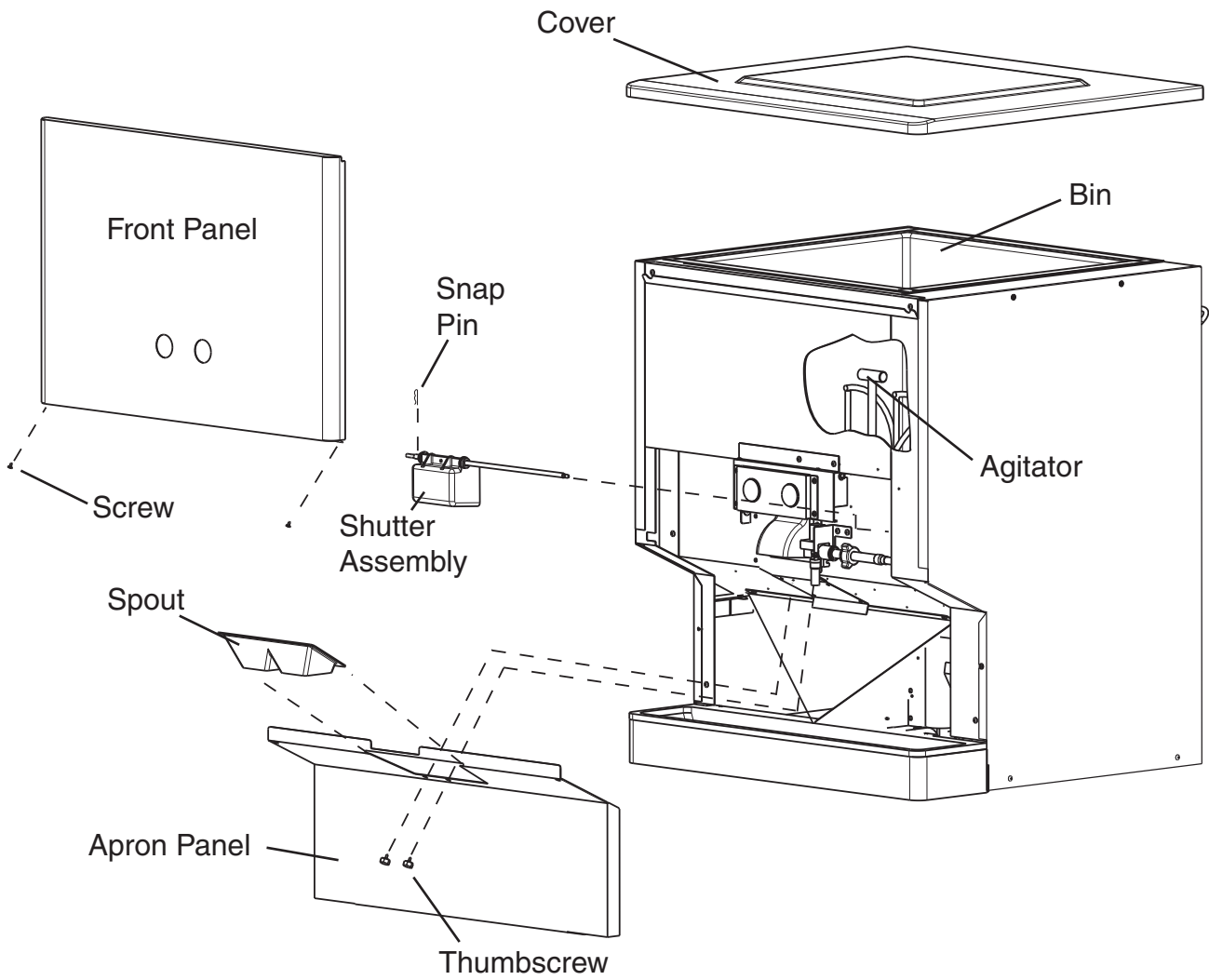

**Fig. 1**

## **B. Maintenance – Exterior Panels**

To prevent corrosion, wipe the exterior occasionally with a clean and soft cloth. Use a damp cloth containing a neutral cleaner to wipe off oil or dirt build up.

## **C. Preparing the Dispenser for Long Storage**

### **CAUTION**

When shutting off the dispenser for an extended time, drain out all water from the water line and remove the ice from the dispensing bin. The bin should be cleaned and dried. Drain the water supply line using air or carbon dioxide to prevent damage to the line at sub-freezing temperatures.

When the dispenser is not used for two or three days, it is sufficient to only remove the ice from the ice dispensing bin and unplug the unit, unless the dispenser will be at sub-freezing temperatures.

- 1) Close the water supply line shut-off valve and open the water supply line drain valve.
- 2) Allow the line to drain by gravity.
- 3) Attach compressed air or carbon dioxide supply to the water supply line drain valve.
- 4) Blow the water supply line out using compressed air or carbon dioxide.
- 5) While pressing the water dispense switch, blow compressed air or carbon dioxide through the water valve.
- 6) Close the water supply line drain valve.
- 7) Remove all ice from the ice dispensing bin.
- 8) Unplug the unit from the electrical outlet.
- 9) Clean and dry the dispensing bin.