

Hoshizaki America, Inc.

Commercial Series Refrigerated Kitchen Equipment

Models
Reach-In B-Series



“A Superior Degree
of Reliability”

www.hoshizaki.com

SERVICE MANUAL



Number: 73183
Issued: 3-23-2011

IMPORTANT

Only qualified service technicians should install, service, and maintain the unit. No service or maintenance should be undertaken until the technician has thoroughly read this Service Manual. Failure to service and maintain the equipment in accordance with this manual may adversely affect safety, performance, component life, and warranty coverage.

Hoshizaki provides this manual primarily to assist qualified service technicians in the service and maintenance of the unit.

Should the reader have any questions or concerns which have not been satisfactorily addressed, please call, write, or send an e-mail message to the Hoshizaki Technical Support Department for assistance.

HOSHIZAKI AMERICA, INC.
618 Highway 74 South
Peachtree City, GA 30269

Attn: Hoshizaki Technical Support Department

Phone: 1-800-233-1940 Technical Support
(770) 487-2331
Fax: 1-800-843-1056
(770) 487-3360
E-mail: techsupport@hoshizaki.com

Web Site: www.hoshizaki.com

NOTE: To expedite assistance, all correspondence/communication MUST include the following information:

- Model Number _____
- Serial Number _____
- Complete and detailed explanation of the problem.

IMPORTANT

This manual should be read carefully before the unit is serviced or maintenance operations are performed. Only qualified service technicians should install, service, and maintain the unit. Read the warnings contained in this booklet carefully as they give important information regarding safety. Please retain this booklet for any further reference that may be necessary.

CONTENTS

Important Safety Information	5
I. Specifications.....	7
A. Nameplate Ratings.....	7
B. Dimensions	7
1. Refrigerated Volume and Shelf Space	7
2. One Section/Two Section/Three Section	8
II. General Information	9
A. Construction	9
1. One Section	9
2. Two Section	10
3. Three Section	11
B. Sequence of Operation	12
1. Sequence Cycles and Shutdown	12
a) Refrigerator.....	12
b) Freezer.....	13
2. Sequence Flow Charts	14
a) Refrigerator.....	14
b) Freezer.....	15
C. Display Module.....	16
1. Display Module Layout	16
2. Controls and Adjustments.....	17
D. Control Module	18
1. Control Module Layout	18
2. Alarm Safeties	19
E. Compressor Overload, Short Cycle Protection, and High-Pressure Switch.....	20
1. Compressor External or Internal Overload.....	20
2. Short-Cycle Protection	20
3. High-Pressure Switch	20
F. Mullion/Perimeter Heater	20
G. Thermistors	20
III. Technical Data	21
A. Refrigeration Circuit	21
B. Wiring Diagrams.....	22
IV. Service Diagnosis	27
A. Diagnostic Procedure	27
1. Refrigerator	28
2. Freezer	30
B. Control Module Check.....	33
C. Thermistor Check.....	34

D. Diagnostic Chart	35
1. Unit Not Cooling	35
2. Evaporator is Frozen Up	36
3. Defrost Fails to Terminate	36
V. Replacement of Components	37
A. Service for Refrigerant Lines.....	37
1. Refrigerant Recovery	37
2. Brazing	38
3. Evacuation and Recharge	38
B. Important Notes for Component Replacement.....	40
C. Door Re-Hinging	40
VI. Cleaning and Maintenance Instructions	41
A. Cleaning	41
1. Exterior.....	41
2. Cabinet Interior	41
3. Door Gaskets.....	41
4. Shelves	41
B. Maintenance.....	41
1. Condenser.....	41
2. Power Supply Connection.....	41
C. Shutdown and Long Storage.....	42

Important Safety Information

Throughout this manual, notices appear to bring your attention to situations which could result in death, serious injury, or damage to the unit.

⚠ WARNING Indicates a hazardous situation which could result in death or serious injury.

CAUTION Indicates a situation which could result in damage to the unit.

IMPORTANT Indicates important information about the use and care of the unit.

⚠ WARNING

This unit should be destined only to the use for which it has been expressly conceived. Any other use should be considered improper and therefore dangerous. The manufacturer cannot be held responsible for injury or damage resulting from improper, incorrect, and unreasonable use.

To reduce the risk of death, electric shock, serious injury, or fire, follow basic precautions including the following:

- Only qualified service technicians should install, service, and maintain the unit.
- Move the power switch to the "OFF" position, then unplug the unit from the electrical outlet before servicing.
- This unit requires an independent power supply. See the nameplate for proper voltage and breaker/fuse size. Failure to use a proper breaker or fuse can result in a tripped breaker, blown fuse, or damage to existing wiring. This could lead to heat generation or fire.
- 115V Units: **THIS UNIT MUST BE GROUNDED.** This unit is equipped with a 3-prong grounding plug to reduce the risk of potential shock hazards. It must be plugged into a properly grounded, independent 3-prong wall outlet. If the outlet is a 2-prong outlet, it is your personal responsibility to have a qualified electrician replace it with a properly grounded, independent 3-prong wall outlet. Do not remove the ground prong from the power cord and do not use an adapter plug. Failure to follow these instructions may result in death, electric shock, or fire.
- 208-230V Units: **THIS UNIT MUST BE GROUNDED:** This unit is equipped with a 4-prong grounding plug to reduce the risk of potential shock hazards. It must be plugged into a properly grounded, independent 4-prong wall outlet. If the outlet is a 3-prong outlet, it is your personal responsibility to have a qualified electrician replace it with a properly grounded, independent 4-prong wall outlet. Do not remove the ground prong from the power cord and do not use an adapter plug. After plugging in, twist the plug clockwise to lock it into place. Failure to follow these instructions may result in death, electric shock, or fire.
- Do not use an extension cord.

- Make sure the power switch is in the "OFF" position before plugging in or unplugging the unit to reduce the risk of electric shock.
- Do not use a unit with a damaged power cord. The power cord should not be altered, jerked, bundled, weighed down, pinched, or tangled. Such actions could result in electric shock or fire. To unplug the unit, be sure to pull the plug, not the cord, and do not jerk the cord. Before unplugging a 4-prong plug, rotate the plug counter-clockwise to unlock it.
- To reduce the risk of electric shock, do not touch the plug or power switch with damp hands.
- Do not make any alterations to the unit. Alterations could result in electric shock, injury, fire, or damage to the unit.

I. Specifications

A. Nameplate Ratings

Model	AC Supply Voltage	Amperes	Design Pressure (PSIG)		Refrigerant (oz.)	
			HIGH	LOW	134a	404A
CR1B-FS/HS	115/60/1	4	240	120	11	-
CF1B-FS/HS		9	450	250	-	8
CR2B-FS/HS		7	240	120	12	-
CF2B-FS/HS		11	450	250	-	17
CR3B-FS/HS	115/60/1	9	240	120	1-Section 11	-
					2-Section 12	
CF3B-FS/HS	208-230/115/60/1	16	450	250	-	1-Section 8
					-	2-Section 17

See the nameplate for electrical and refrigeration specifications. The nameplate is located inside the cabinet.

Note: We reserve the right to make changes in specifications and design without prior notice.

B. Dimensions

1. Refrigerated Volume and Shelf Space

Model	Interior Storage Capacity (ft ³)	Total Shelf Space (ft ²)
CR1B-FS/HS CF1B-FS/HS	21	11.5
CR2B-FS/HS CF2B-FS/HS	47	24.6
CR3B-FS/HS CF3B-FS/HS	68	36.1

Note: We reserve the right to make changes in specifications and design without prior notice.

2. One Section/Two Section/Three Section

Unit: mm (in.)

Top View

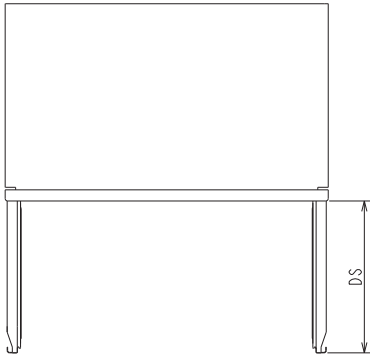

Model	Exterior Width (W)	Exterior Height (H)	Exterior Depth (D)	Door Opening Width (DW)		Door Opening Height (DH)	Door Opening Height (DHU/DHL)	Door Swing (DS)
One Section	698.5 (27.5)	1920.5 (75.61)	852.9 (33.58)	579 (22.8)		1513.6 (59.59)	713.3/710.3 (28.08/27.96)	651.3 (25.64)
Two Section	1397 (55)			593.7 (23.37)				
Three Section	2108.2 (83)			593.7 (23.37)	579 (22.8)			

Front View

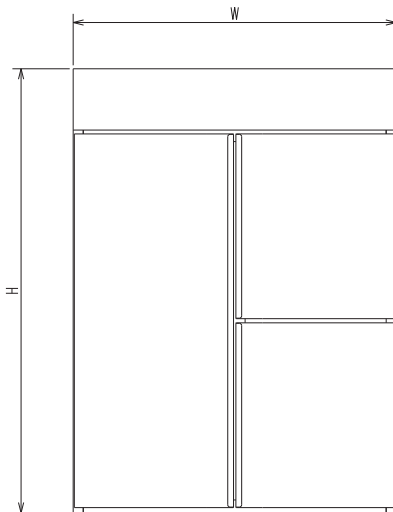

Side View

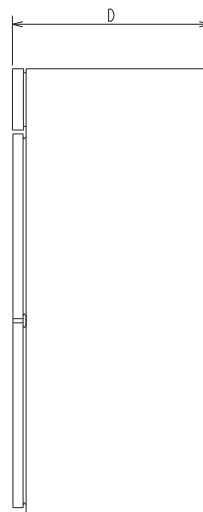

Interior View

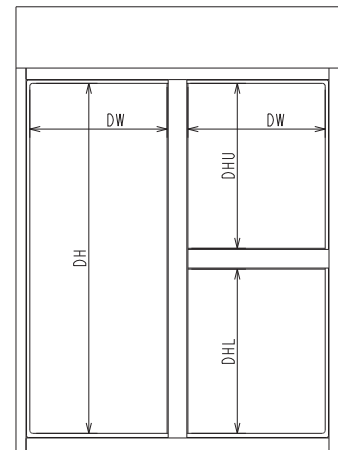

Additional Dimensions								
Model	Interior Width		Interior Height	Interior Depth	Door Stay Open Position	Caster Height (Standard)	Caster Height (Option)	Leg Height (Option)
One Section	579 (22.8)		1513.6 (59.59)	711.2 (28)	80°	101.6 (4)	152.4 (6)	153±28.6 (6.02±1.13)
Two Section	1277.5 (50.3)							
Three Section	1277.5 (50.3)	579 (22.8)						

II. General Information

A. Construction

1. One Section

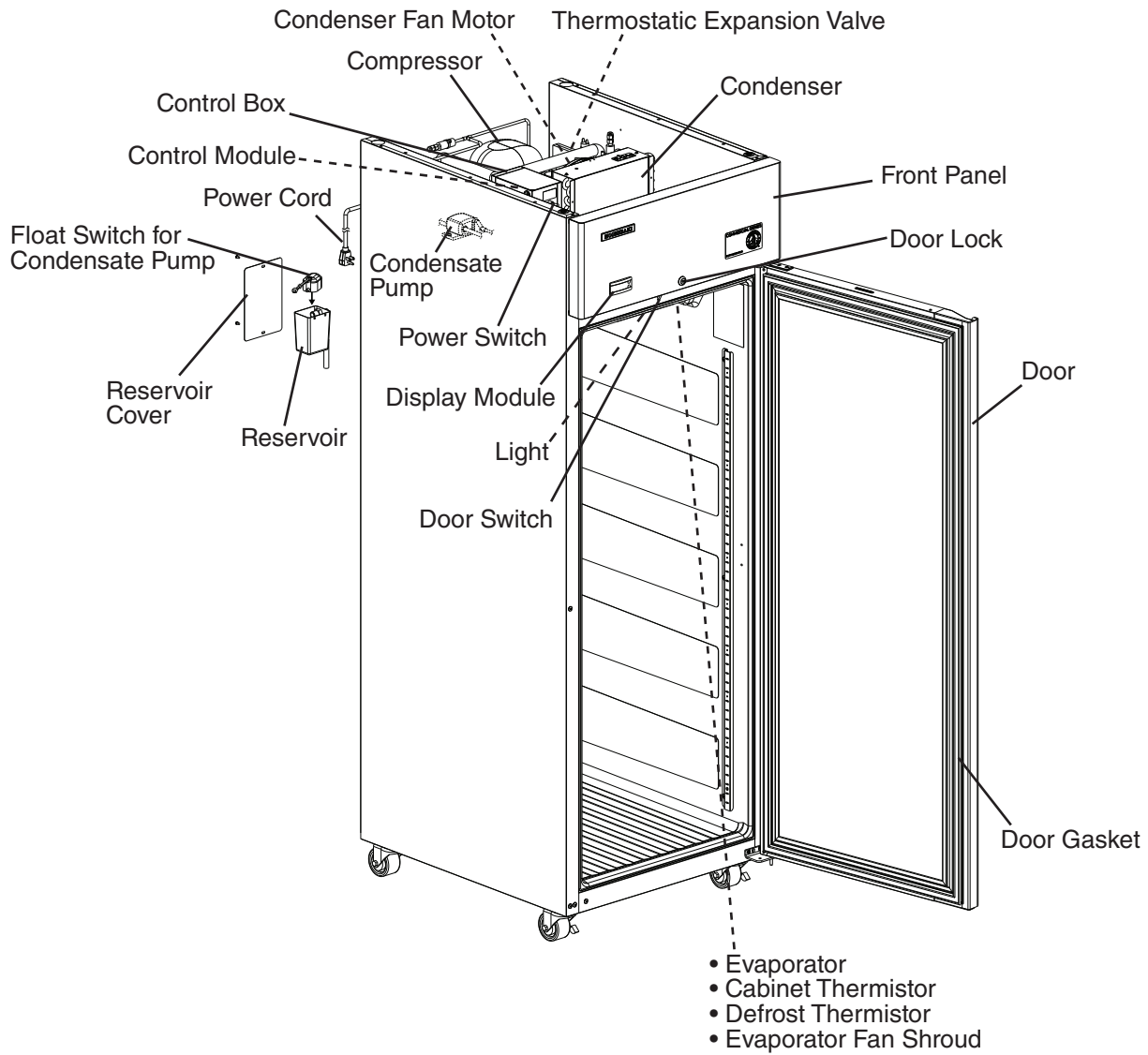

Model Shown: CR1B-FS

Models
CR1B-FS/HS and CF1B-FS/HS

2. Two Section

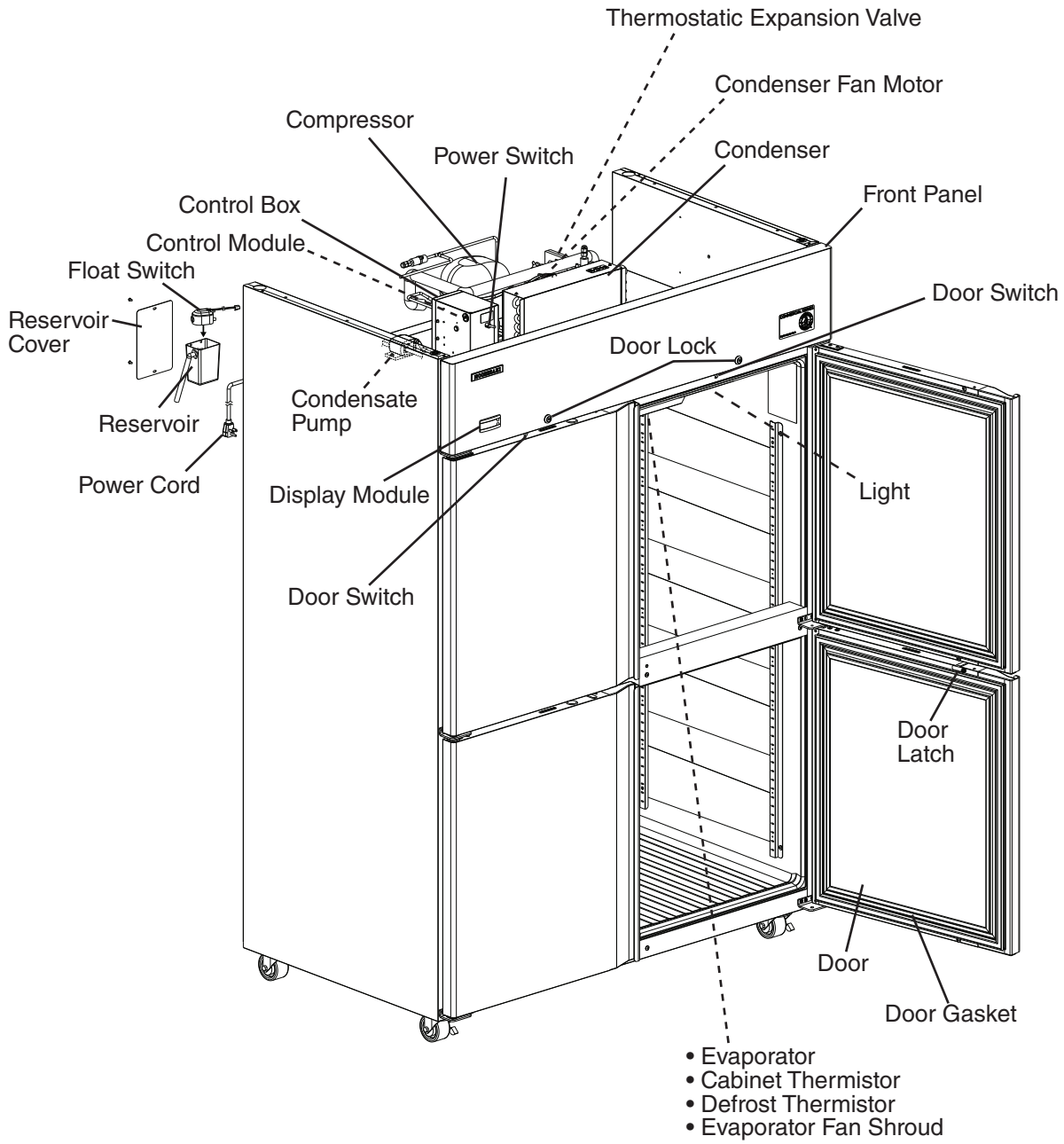

Model Shown: CR2B-HS

Models
CR2B-FS/HS and CF2B-FS/HS

3. Three Section

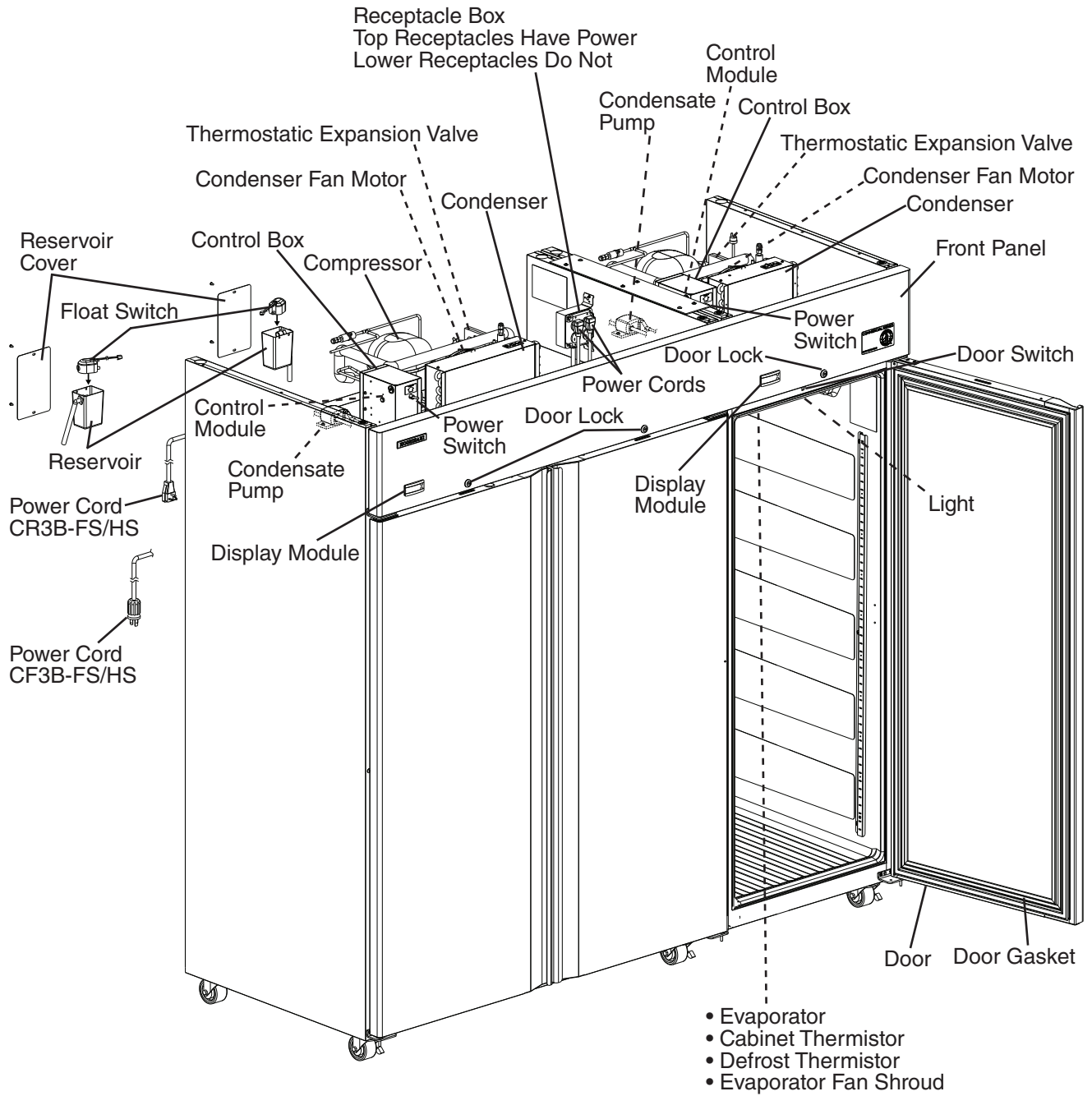

Model Shown: CR3B-FS

Models
CR3B-FS/HS and CF3B-FS/HS

B. Sequence of Operation

1. Sequence Cycles and Shutdown

The steps in the sequence are as outlined below.

Note: 1. There is a slight delay at startup.

2. When power is turned on, the 2-hour high-temperature alarm timer is bypassed. Therefore, a high-temperature alarm can occur at startup. To silence the alarm, press and release the upper button. Alarm clears once temperature is within factory parameters. For details, see "II.D.2. Alarm Safeties."
3. There is a 2-minute minimum Comp on time and a 2-minute minimum Comp off time.
4. EvapFM de-energizes when door is opened on FS and when upper door is opened on HS.
5. A float-switch controlled condensate pump (located on top of the unit) is used to pump evaporator condensation to the condensate pan.
6. On freezers, EvapFM is de-energized during defrost.

a) Refrigerator

1. Startup/Cool Down

EvapFM and MH energize. There is a slight delay before cabinet temperature or high-temperature alarm (Hi) appears on DM and Comp and ConFM energize.

2. Cool Down Achieved

CM monitors cooling of the cabinet via CTh. CTh cools to 3°F (1.7°C) below setpoint. EvapFM and MH continue. Comp and ConFM de-energize.

3. Cool Down Restart

CTh warms to 3°F (1.7°C) above setpoint. EvapFM and MH continue. Comp and ConFM energize.

4. Defrost

"dEF" is displayed during defrost. There is a 20-minute minimum defrost time and a 1-hour maximum defrost time.

- a) Temperature Initiation: When DTh cools to 8.6°F (-13°C) defrost begins. EvapFM and MH continue. Comp and ConFM de-energize.
- b) Manual Initiation: Manual defrost may be initiated by pressing and holding the lower button until "dEF" appears on DM. EvapFM and MH continue. Comp and ConFM de-energize.
- c) Termination: DTh warms to 40°F (4.4°C). EvapFM and MH continue. Comp and ConFM energize, 2-minute temperature display delay timer starts.
2-minute temperature display delay timer terminates and temperature display returns to DM.

Note: There is a 2-hour minimum defrost interval.

Legend: **CM**—control module; **Comp**—compressor; **ConFM**—condenser fan motor; **CTh**—cabinet thermistor; **DM**—display module; **DTh**—defrost thermistor; **EvapFM**—evaporator fan motor; **MH**—mullion heater

b) Freezer

1. Startup/Cool Down

MH and PH energize. There is a slight delay before cabinet temperature or high-temperature alarm (Hi) appears on DM and Comp, ConFM, and EvapFM energize.

2. Cool Down Achieved

CM monitors cooling of the cabinet via CTh. CTh cools to 3°F (1.7°C) below setpoint. EvapFM, MH, and PH continue. Comp and ConFM de-energize.

3. Cool Down Restart

CTh warms to 3°F (1.7°C) above setpoint. EvapFM, MH, and PH continue. Comp and ConFM energize.

4. Defrost

"dEF" is displayed during defrost. There is a 5-minute minimum defrost time and a 1-hour maximum defrost time.

a) Temperature/Time Initiation: DTh cools to 32°F (0°C), then a 4-hour cumulative Comp run timer starts. Once 4-hour cumulative Comp run timer terminates and DTh is at or below 32°F (0°C), defrost begins. DH energizes, MH and PH continue, Comp, ConFM, and EvapFM de-energize.

b) Manual Initiation: Manual defrost may be initiated by pressing and holding the lower button until "dEF" appears on DM. MH and PH continue. DH energizes, Comp, ConFM, and EvapFM de-energize.

c) Termination

(1) After Temperature/Time Initiation: DTh warms to 59°F (15°C). 3-minute Comp delay timer starts, 8-minute EvapFM delay timer starts, and 13-minute temperature display delay timer starts. MH and PH continue, DH de-energizes.

3-minute Comp delay timer terminates. Comp and ConFM energize. 5 minutes later, 8-minute EvapFM delay timer terminates and EvapFM energizes. 5 minutes after EvapFM energizes, 13-minute temperature display delay timer terminates and cabinet temperature returns to DM.

(2) After Manual Initiation: DTh warms to 59°F (15°C). MH and PH continue, DH de-energizes. 3-minute Comp/EvapFM delay timer starts, 13-minute temperature display delay timer starts.

3-minute Comp/EvapFM delay timer terminates. Comp, ConFM, and EvapFM energize. 10 minutes later, 13-minute temperature display delay timer terminates and cabinet temperature returns to DM.

Note: There is a 4-hour minimum defrost interval.

Legend: **CM**—control module; **Comp**—compressor; **ConFM**—condenser fan motor; **CTh**—cabinet thermistor; **DH**—defrost heater; **DM**—display module; **DTh**—defrost thermistor; **EvapFM**—evaporator fan motor; **MH**—mullion heater; **PH**—perimeter heater

2. Sequence Flow Charts

a) Refrigerator

Refrigerator Sequence Flow Chart

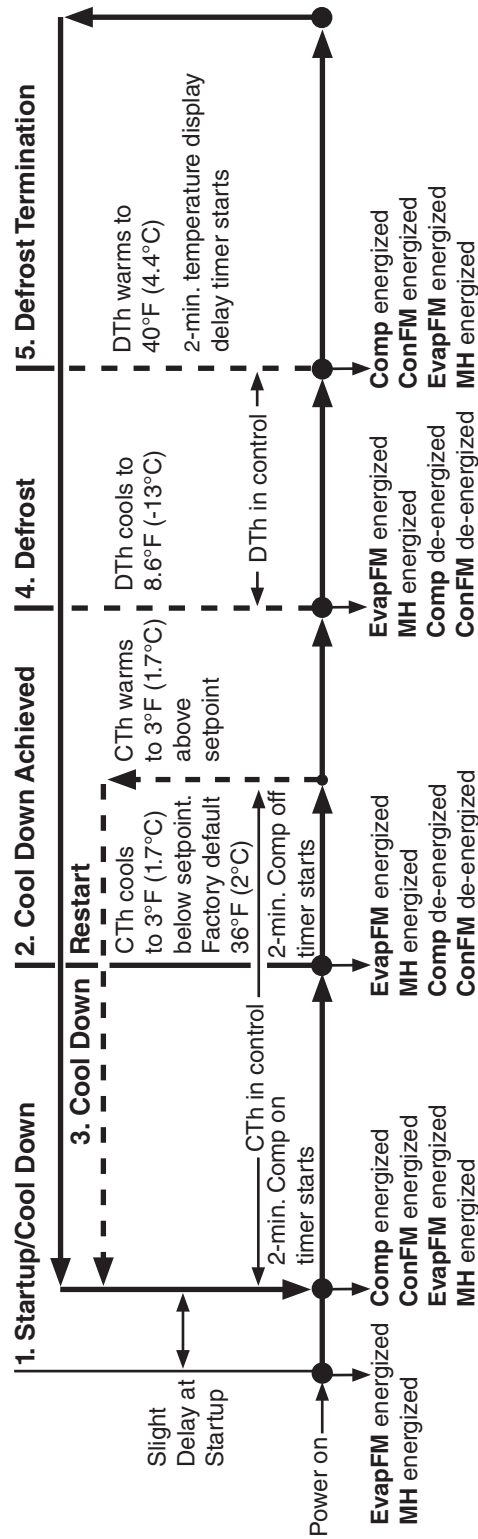

Note:

- a) EvapFM de-energizes when door is opened on FS and when upper door is opened on HS.
- b) 2-minute minimum Comp on timer starts when Comp energizes.
- c) 2-minute minimum Comp off timer starts when Comp de-energizes.
- d) 2-minute temperature display delay timer starts when defrost termination temperature is met.
- e) 20-minute minimum defrost time.
- f) 1-hour maximum defrost time.

Legend:

- Comp-compressor
- ConFM-condenser fan motor
- CTh-cabinet thermistor
- DTh-defrost thermistor
- EvapFM-evaporator fan motor
- MH-mullion heater

b) Freezer

Freezer Sequence Flow Chart

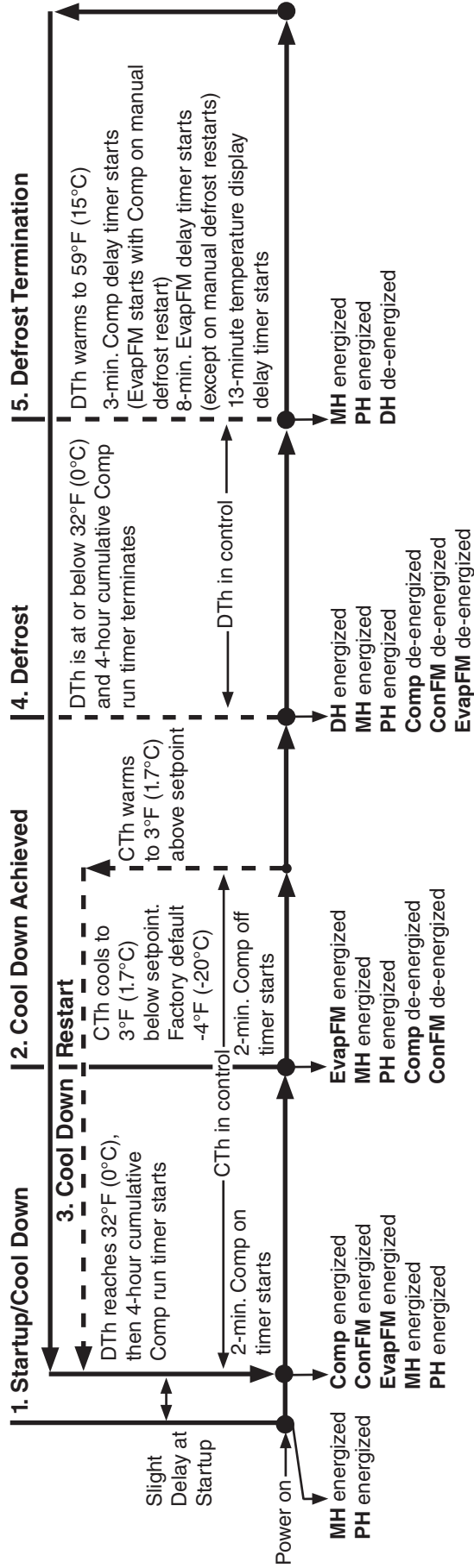

Note:

- a) EvapFM de-energizes when door is opened on FS and when upper door is opened on HS.
- b) 2-minute minimum Comp on timer starts when Comp energizes.
- c) 2-minute minimum Comp off timer starts when Comp de-energizes.
- d) 3-minute Comp delay timer starts when defrost termination temperature is met.
- e) 8-minute EvapFM delay timer starts when defrost termination temperature is met. (3-minute delay timer if defrost initiated manually)
- f) 13-minute temperature display delay timer starts when defrost termination temperature is met.
- g) 5-minute minimum defrost time.
- h) 1-hour maximum defrost time.

Legend:
Comp-compressor
ConFM-condenser fan motor
CTh-cabinet thermistor
DH-defrost heater
DTh-defrost thermistor
EvapFM-evaporator fan motor
MH-mullion heater
PH-perimeter heater

C. Display Module

When the power switch is moved to the "ON" position there is a slight delay, then the current cabinet temperature is displayed. From the display module, the cabinet setpoint and temperature display scale can be changed. For further details, see "II.C.2. Controls and Adjustments."

Note: When power is turned on, the 2-hour high-temperature alarm timer is bypassed.

Therefore, a high-temperature alarm can occur at startup. To silence the alarm, press and release the upper button. Alarm clears once temperature is within factory parameters. For details, see "II.D.2. Alarm Safeties."

1. Display Module Layout

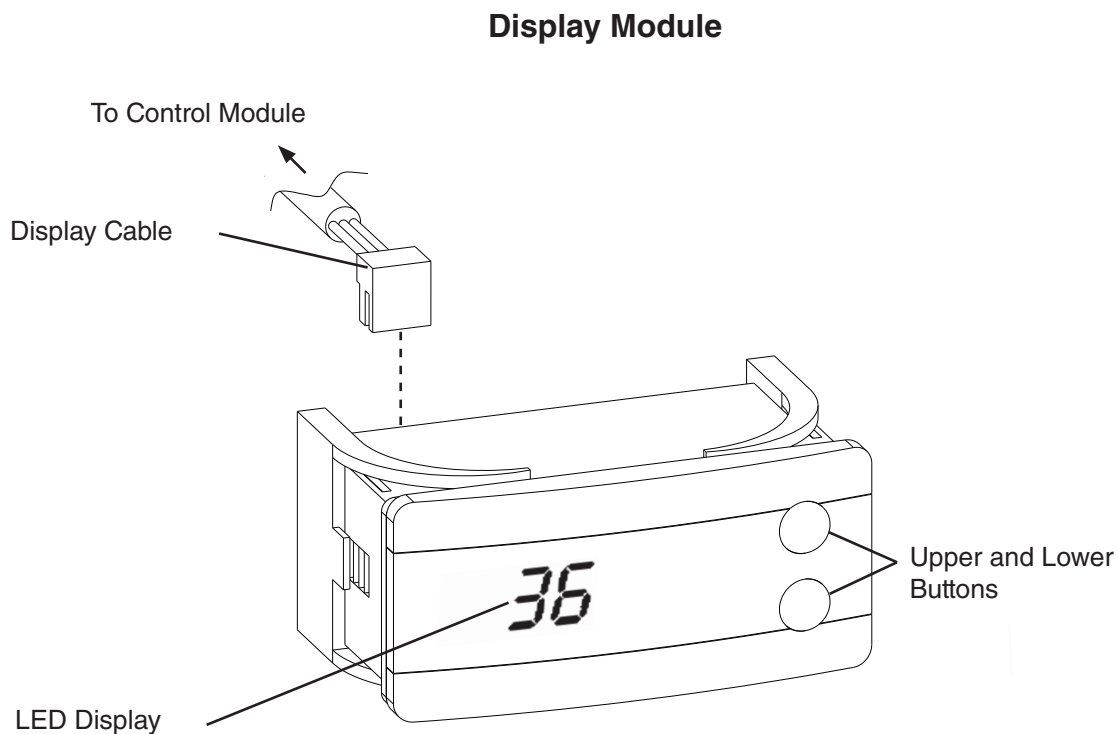

Fig. 1

2. Controls and Adjustments

a) *Default Settings*

1. Temperature Setting: Refrigerator: 36°F (2°C).
Freezer: -4°F (-20°C).
2. Temperature Display Scale: F.

b) *Temperature Setpoint*

The temperature setpoint is the value for the average cabinet temperature. The temperature differential for the compressor to turn on and off is $\pm 3^{\circ}\text{F}$ ($\pm 1.7^{\circ}\text{C}$) of the temperature setpoint. For example, for a refrigerator temperature setpoint of 36°F (2°C), the compressor comes on at 39°F (3.7°C), and the compressor goes off at 33°F (0.3°C). If necessary, adjust the temperature setpoint as follows:

- 1) Press and hold the upper or lower button briefly, then release. The current temperature setpoint flashes. Press the upper or lower button until the desired value is displayed. After a few seconds, the display returns to the current cabinet temperature and the temperature setpoint is saved.
 - For refrigerators, the temperature setpoint is adjustable between 34°F and 52°F (1°C and 11°C). Factory default is 36°F (2°C).
 - For freezers, the temperature setpoint is adjustable between -15°F and +12°F (-26°C and -11°C). Factory default is -4°F (-20°C).

Note: Do not adjust the temperature setpoint outside of the factory-specified range. Adjustment outside of this range may prevent the unit from operating correctly.

c) *Changing the Temperature Display Scale (F or C)*

To change the temperature display scale, press the upper button for 5 seconds. The current setting is displayed. Press the upper button to change the scale. After a few seconds, the display returns to the current cabinet temperature and the setting is saved. The factory default is F.

Note: Pressing the upper and lower button at the same time for 5 seconds (or until "- - -" appears on the display module), turns the compressor, condenser fan motor, and evaporator fan motor (freezer) off. To turn the unit on again, press the upper and lower button together for 5 seconds until the cabinet temperature appears on the display module. **CAUTION! The three dashes must be cleared, otherwise the compressor will not run and product will be lost.**

d) *Manual Defrost*

Manual defrost may be initiated by pressing and holding the lower button for 5 seconds. "dEF" appears in the display. For further details, see "II.B.1. Sequence Cycles and Shutdown."

D. Control Module

All models are pretested and factory set.

CAUTION

1. The control module is fragile, handle very carefully.
2. Do not change wiring and connections. Never misconnect terminals.
3. Do not short out power supply to test for voltage.

1. Control Module Layout

Refrigerator Control Module

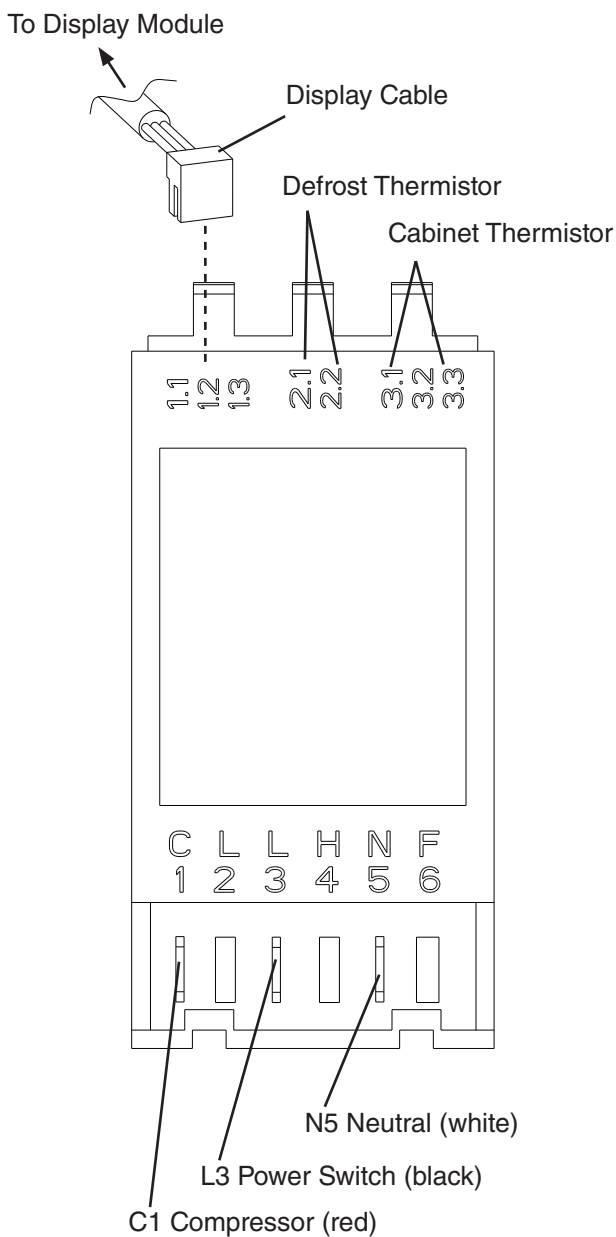

Freezer Control Module

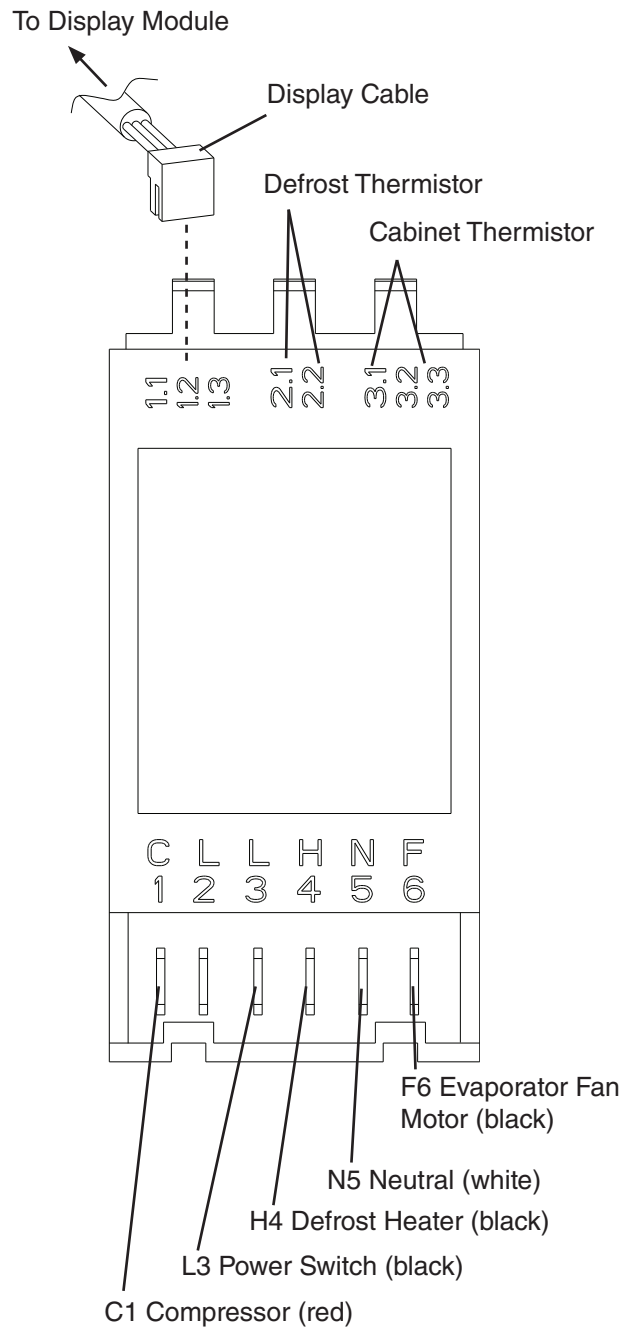

Fig. 2

2. Alarm Safeties

Alarm signals are designed to protect the unit and food product. These alarms give information or warnings in the event the unit is operating out of acceptable parameters. Should one of the alarms occur, follow the instructions in the table below to address the alarm. The alarm code flashes once every second with audible alarm. To silence the alarm, press and release the upper button.

Alarm Signals		
Alarm Code	Problem	Corrective Action/Reset Details
E1	Cabinet Thermistor Malfunction Alarm Cabinet thermistor has failed.	Cabinet thermistor disconnected, shorted, or open. Check connection and continuity. Reconnect or replace as needed. Unit cycles 5 min. on, 5-min. off.
E2	Defrost Thermistor Malfunction Alarm Defrost thermistor has failed.	Defrost thermistor disconnected, shorted, or open. Check connection and continuity. Reconnect or replace as needed. Unit cycles on and off with cabinet thermistor.
UHi	High-Voltage Alarm (135VAC±5% or more)	The compressor de-energizes if voltage protection operates. The voltage safeties automatically reset when voltage is corrected.
ULo	Low-Voltage Alarm (96VAC±5% or less)	
Hi	High-Temperature Alarm Note: When power is turned on, the 2-hour high-temperature alarm timer is bypassed. Therefore, a high-temperature alarm can occur at startup. Refrigerator: Cabinet temperature has exceeded the setpoint temperature by 10°F (5.6°C) for more than 2 hours. Freezer: Cabinet temperature has exceeded the setpoint temperature by 27°F (15°C) for more than 2 hours.	First try obvious corrections such as closing doors and cleaning the condenser. Automatically resets when temperature returns to normal.
Lo	Low-Temperature Alarm Refrigerator & Freezer: Cabinet temperature has remained below the setpoint temperature by 8°F (4.4°C) for more than 2 hours.	Automatically resets when temperature returns to normal.
E13	Communication Error Alarm Communication between the control module and the display module has been interrupted or disconnected.	Check the connections at the control module and the display module. If connections are good, the control module and display module must be replaced. The unit operates on a set 5-minutes on, 5-minutes off cycle until communication is restored.
"_ _ _"	Compressor Off	Unit (compressor) off. Press and hold the upper and lower buttons until the temperature appears on the display.

E. Compressor Overload, Short Cycle Protection, and High-Pressure Switch

1. Compressor External or Internal Overload

If combined temperature/amperage value is above the limit specified by the compressor manufacturer, the compressor overload operates independently to turn off the compressor. The compressor overload de-energizes the compressor until the temperature/amperage value returns to an acceptable level.

- If the condenser fan motor is operating and the compressor is off, it is most likely that the compressor overload opened. If both the compressor and condenser fan motor are off, it is most likely the unit is off or the high-pressure switch has opened. For further details, see "IV. Service Diagnosis."
- On refrigerators, the compressor overload is integrated with the start relay. On 1-section freezers, the compressor overload is internal. On 2-section freezers, the compressor overload is external.

2. Short-Cycle Protection

There is a 2-minute minimum off-time and on-time for the compressor.

Note: Time may vary with compressor overload or high-pressure switch activation.

3. High-Pressure Switch

If pressure on the high-side of the unit exceeds Hoshizaki specifications, the high-pressure switch activates and interrupts the compressor circuit, de-energizing the compressor until the pressure returns to an acceptable level.

F. Mullion/Perimeter Heater

Refrigerators and freezers with mullions are equipped with mullion heaters. Freezers are also equipped with perimeter heaters. The heaters are energized as soon as the power switch is turned on.

G. Thermistors

The cabinet thermistor is used for cabinet temperature control and the defrost thermistor is used for defrost cycle initiation and termination. Thermistor resistance varies depending on temperature. The control module monitors the resistance to control system operation. No adjustment is required. For further details, see "IV.C. Thermistor Check."

III. Technical Data

A. Refrigeration Circuit

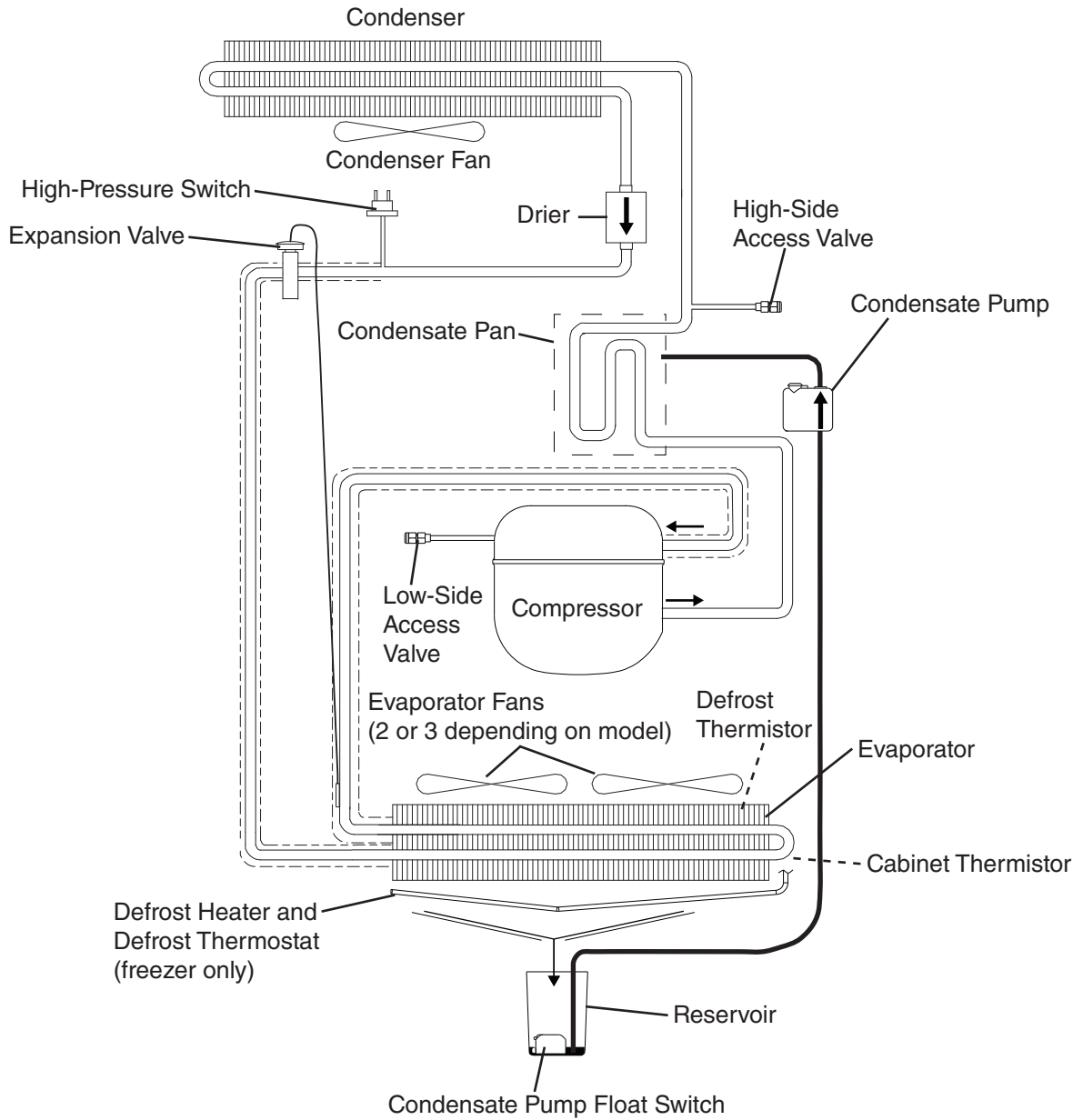

B. Wiring Diagrams

1. CR1B-FS/HS, CR3B-FS/HS

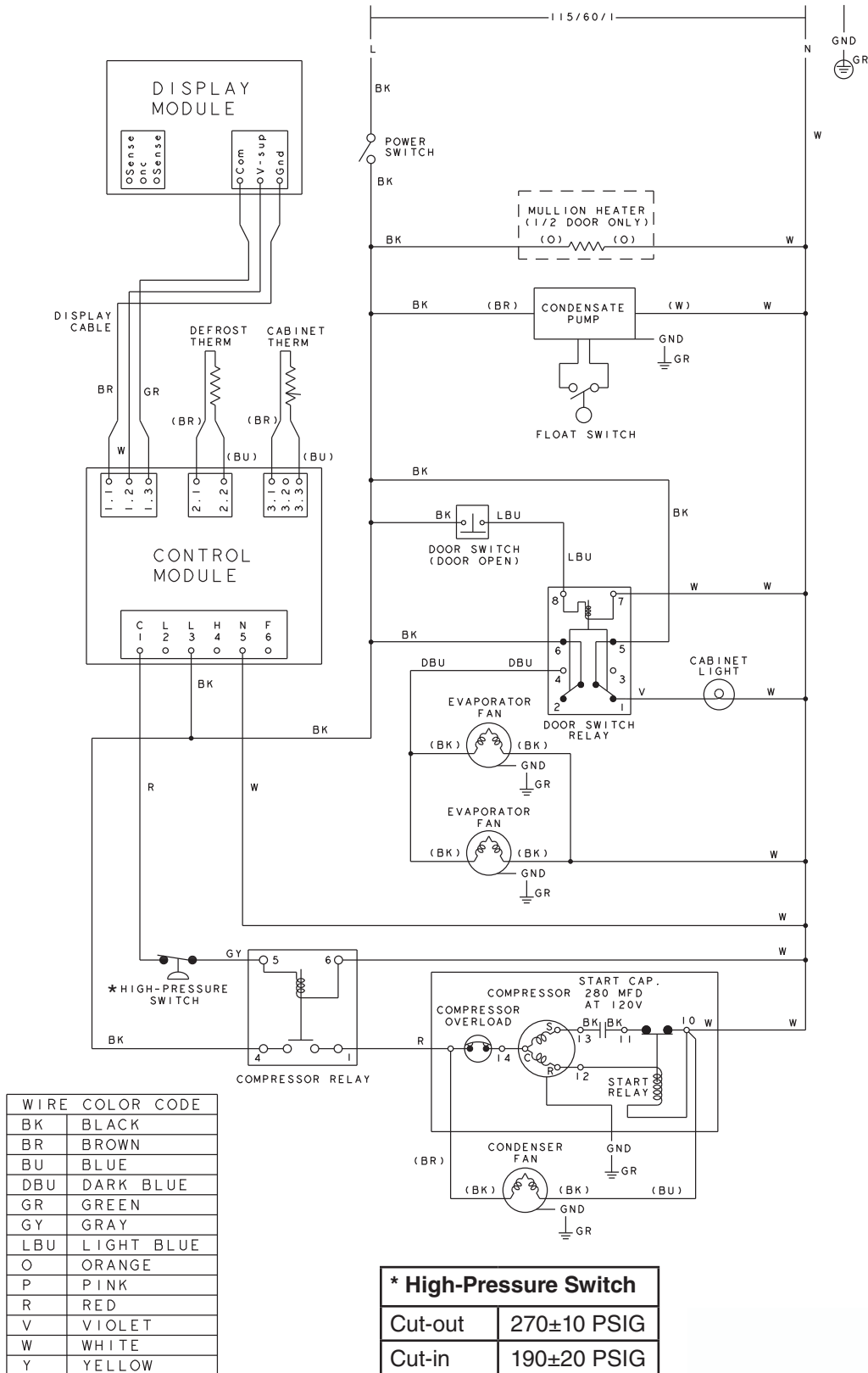

2. CR2B-FS/HS, CR3B-FS/HS

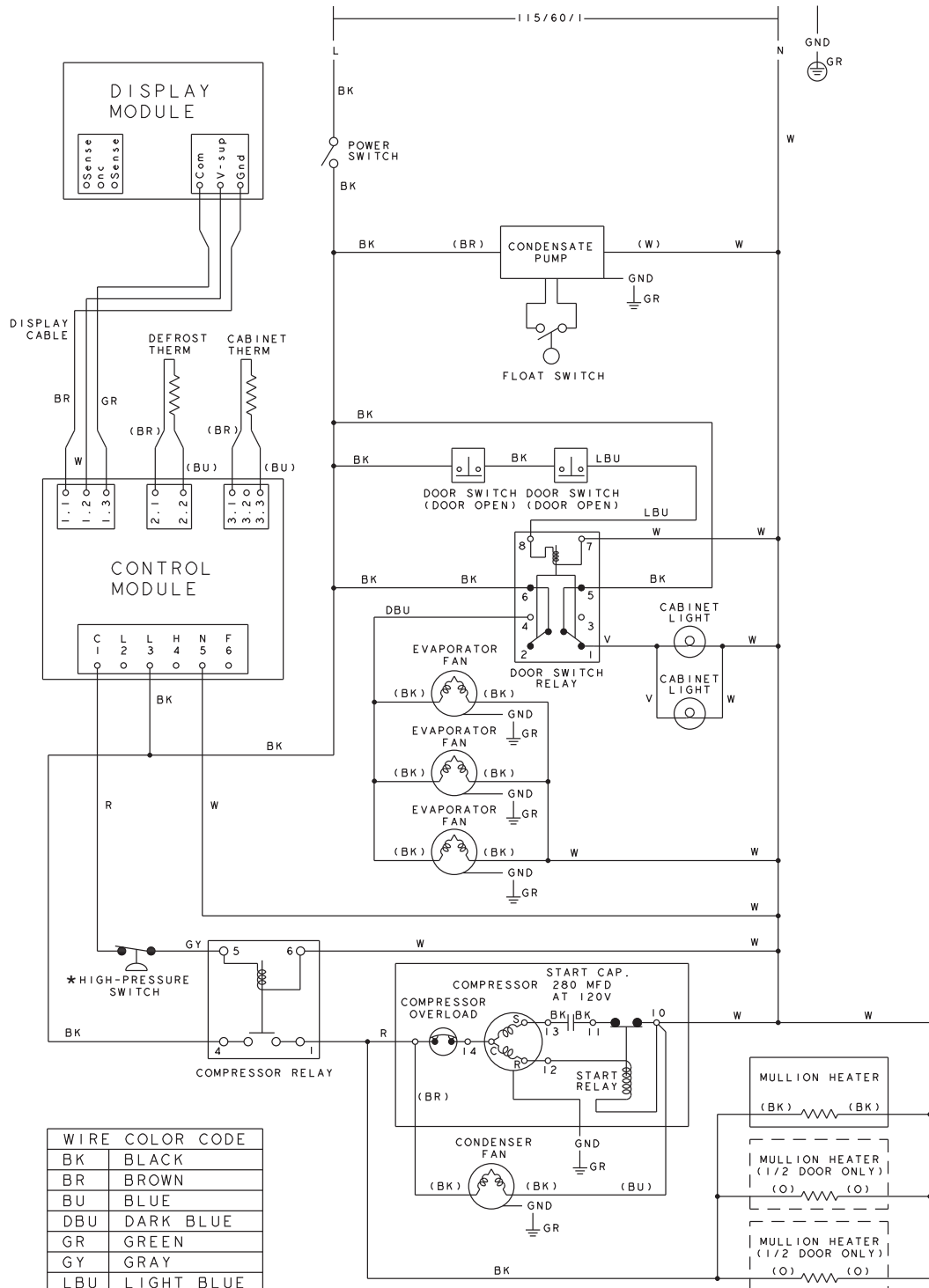

3. CF1B-FS/HS, CF3B-FS/HS

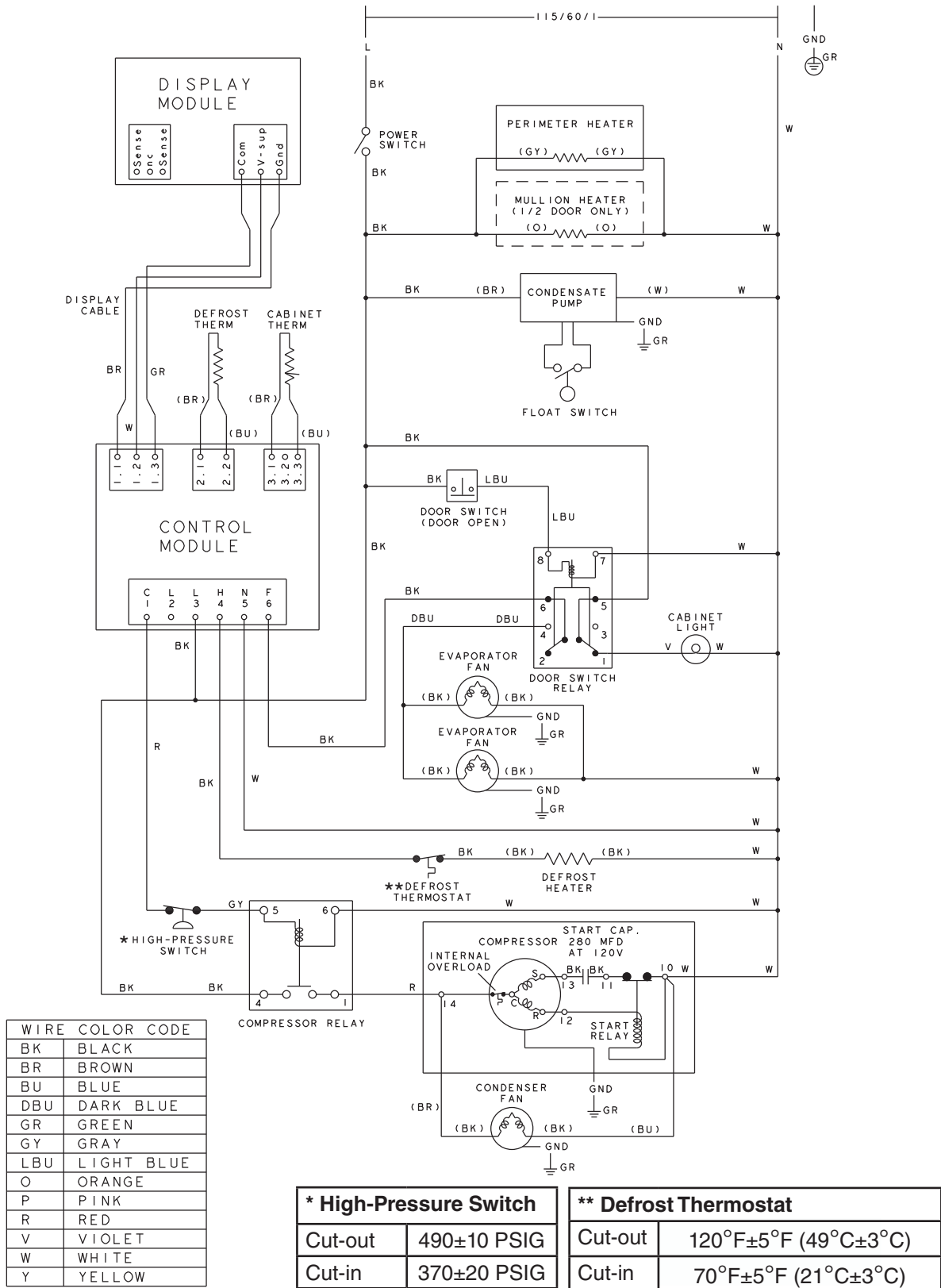

4. CF2B-FS/HS, CF3B-FS/HS

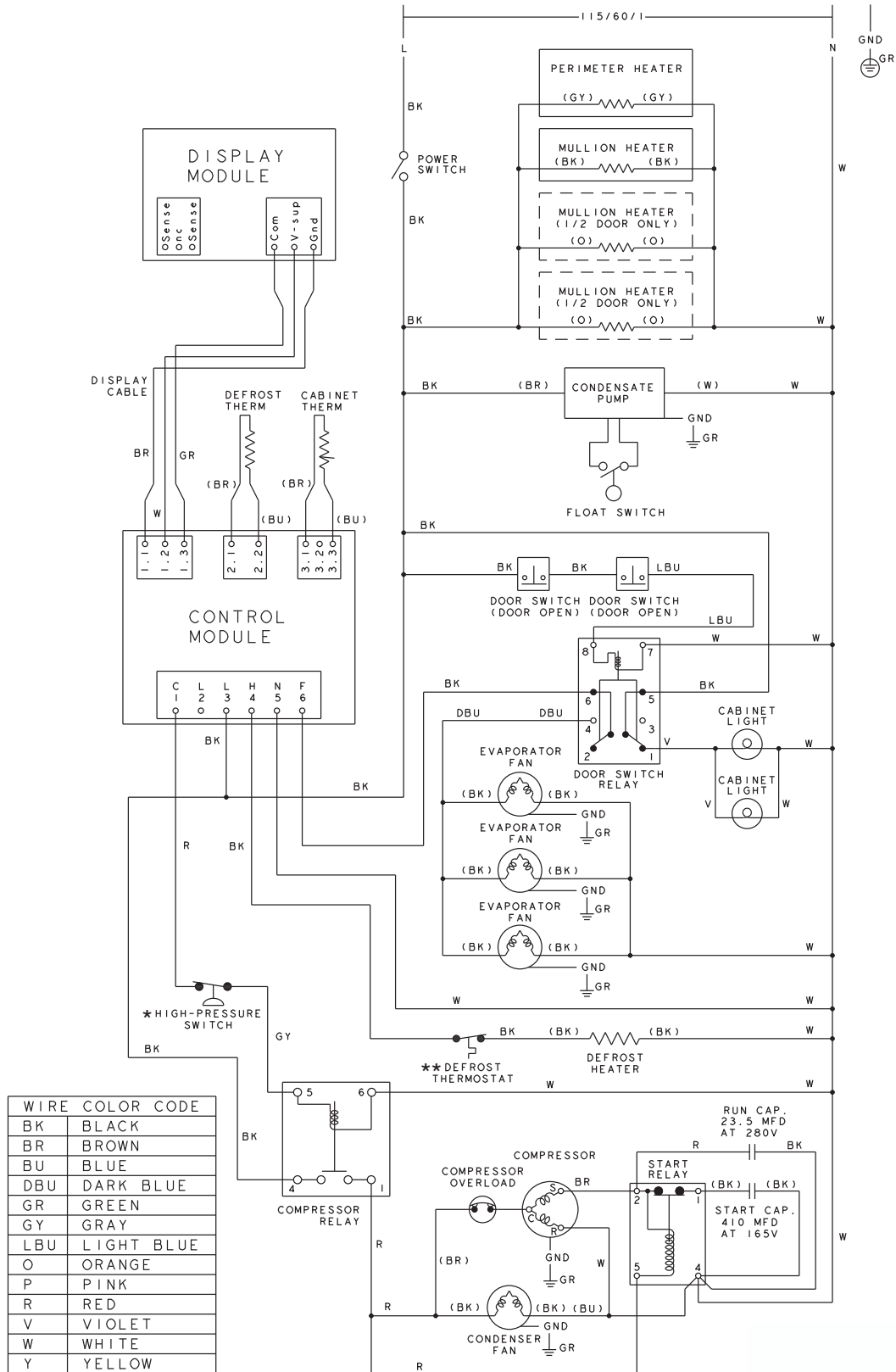

* High-Pressure Switch

Cut-out	490±10 PSIG
Cut-in	370±20 PSIG

** Defrost Thermostat

Cut-out	120°F±5°F (49°C±3°C)
Cut-in	70°F±5°F (21°C±3°C)

5. CR3B-FS/HS Receptacle Box Connection

WIRE COLOR CODE	
BK	BLACK
GR	GREEN
W	WHITE

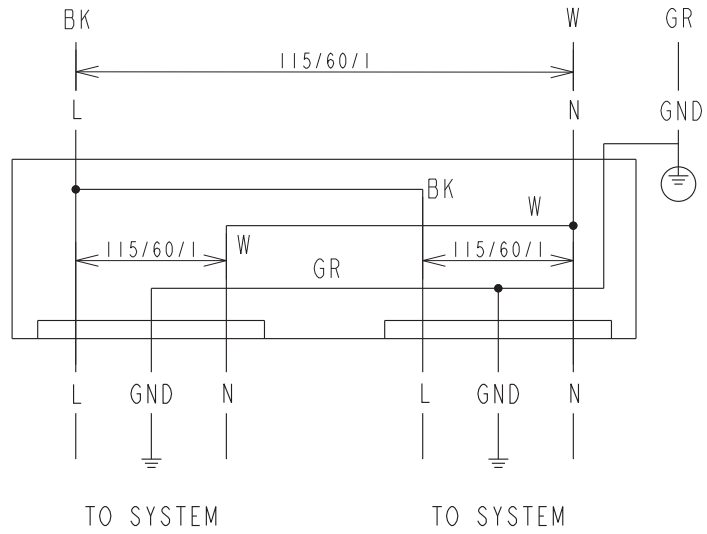
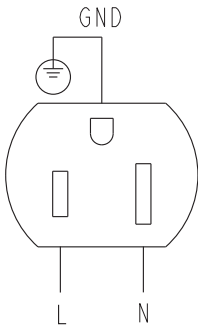

Note: Only the top receptacles have power.

6. CF3B-FS/HS Receptacle Box Connection

WIRE COLOR CODE	
BK	BLACK
GR	GREEN
R	RED
W	WHITE

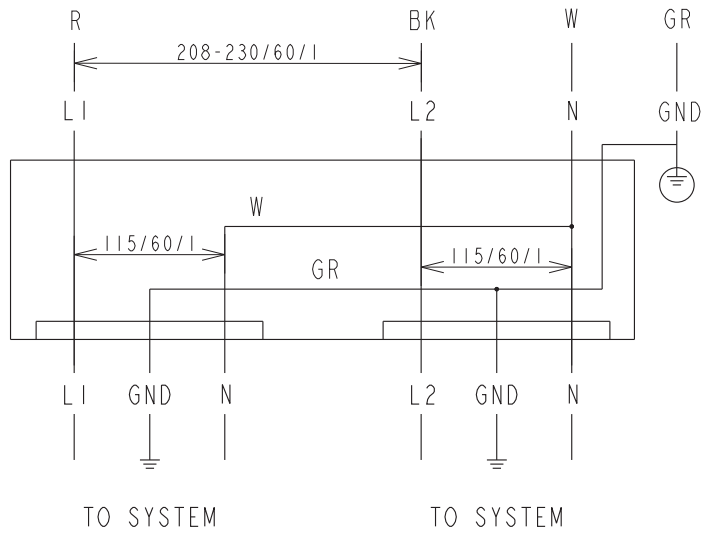
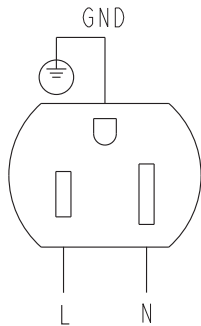

Note: Only the top receptacles have power.

IV. Service Diagnosis

⚠ WARNING

1. This unit should be diagnosed and repaired only by qualified service personnel to reduce the risk of death, electric shock, serious injury, or fire.
2. Risk of electric shock. Use extreme caution and exercise safe electrical practices.
3. Moving parts (e.g., fan blade) can crush and cut. Keep hands clear.
4. Make sure all food zones are clean after the unit is serviced. For cleaning procedures, see "VI. Cleaning Instructions."

A. Diagnostic Procedure

The diagnostic procedure is basically a sequence check that allows you to diagnose the electrical system and components. Before proceeding, check for correct installation and proper voltage per unit nameplate. As you go through the diagnostic procedure, check to assure the components energize and de-energize correctly. If not, those components or controls are suspect. Always choose a white (W) neutral wire to establish a good neutral connection when checking high voltages. If the display module is in alarm, see "II.D.2. Alarm Safeties." For further details, see "IV.B. Control Module Check." For factory default settings, see "II.C.2.a) Default Settings."

Note: When power is turned on, the 2-hour high-temperature alarm timer is bypassed. Therefore, a high-temperature alarm can occur at startup. To silence the alarm, press and release the upper button. Alarm clears once temperature is within factory parameters.

IMPORTANT

The maximum allowable voltage variation is ± 10 percent of the nameplate rating. 115VAC is used as a reference voltage when checking voltage to components. Voltage may vary depending on power supply.

- 1) Move the power switch to the "OFF" position.
- 2) Unplug the unit from the electrical outlet.
- 3) Remove the control box cover.
- 4) Plug the unit back into the electrical outlet.
- 5) Move the power switch to the "ON" position.
- 6) Confirm proper supply voltage (115VAC) to the power switch. On 3-section units, also confirm proper supply voltage to the receptacle box (115VAC for refrigerator/208-230VAC for freezer).

Continue to "IV.A.1. Refrigerator" or "IV.A.2. Freezer."

1. Refrigerator

7) **Startup/Cool Down**—EvapFM and MH energize. There is a slight delay, then Comp and ConFM energize and cabinet temperature or high-temperature alarm (Hi) appears on DM.

a) **Startup Diagnosis:** Check that EvapFM energize. If not, confirm that the door(s) are closed and DS contacts are closed. Check EvapFM blades for binding. Next, check for 115VAC at DSR terminals 7 and 8. If 115VAC is not present, check DS continuity. If 115VAC is present, check DSR coil continuity and contact continuity between terminals 6 and 4. If coil or contacts are open, DSR is bad and must be replaced. If DSR is good, check EvapFM continuity.

b) **Cool Down Diagnosis:** Confirm that Comp and ConFM energize and cabinet temperature appears on DM. If not, confirm 115VAC between CM L3 and CM N5. If 115VAC is not present, confirm wiring connections are secure for both the power wire (CM L3) and the neutral wire (CM N5). If 115VAC is present and DM is off, check that the display cable between CM and DM is not disconnected; reconnect if loose. If DM is still off, CM or DM may be bad, so replace both. Next, check that Comp and ConFM are energized. If not, check for 115VAC between CM C1 and CM N5. If 115VAC is present between CM L3 and CM N5 (above) and not between CM C1 and CM N5, check CTh status. See "IV.C.Thermistor Check." If CTh ohm reading is in proper range, CM is bad and must be replaced. If 115VAC is present between CM C1 and CM N5, check for 115VAC on CR coil (terminals 5 and 6). If 115VAC is not present between CR 5 and CR 6, check continuity of HPS. If open, allow time for HPS to reset. If HPS does not reset, replace HPS and diagnose reason for HPS activation. See "IV.A.1.7)c) HPS Activation." If 115VAC is present between CR 5 and CR 6, and Comp and ConFM are not energized, check for 115VAC between CR terminal 4 and neutral and CR terminal 1 and neutral. If 115VAC is present between CR terminal 4 and neutral and not CR terminal 1 and neutral, CR is defective and must be replaced. If CR is good and Comp or ConFM are not energized, check for 115VAC at Comp terminals, Comp overload (integrated with start relay), start components, and Comp and ConFM motor winding continuity.

If Comp and ConFM are energized and the cabinet does not cool down, check for a restriction in the refrigeration circuit, correct TXV operation, and correct refrigerant charge.

c) **HPS Activation:** Confirm ConFM is energized and fan blade turns freely. Check that the condenser coil is not clogged or restricted. Check that there are no restrictions in the refrigeration circuit.

Confirm that unit location meets factory requirements:

- This unit is not intended for outdoor use. Normal operating ambient temperature should be within 45°F to 100°F (7°C to 38°C).
- The unit should not be located next to ovens, grills, or other high heat producing equipment.
- The unit should not be located in a corrosive environment.
- The unit should be a minimum of 4" (11 cm) from side walls.
- A minimum of 10" (25 cm) overhead clearance should be provided for proper ventilation.

8) **Cool Down Achieved**—CTh cools to 3°F (1.7°C) below setpoint. EvapFM and MH continue. Comp and ConFM de-energize. **Diagnosis:** If Comp and ConFM do not de-energize, confirm CTh status. See "IV.C. Thermistor Check." If CTh ohm reading is in range and Comp and ConFM do not de-energize, CM is defective and must be replaced.

9) **Defrost**

Temperature-Initiated Defrost: DTh cools to 8.6°F (-13°C). EvapFM and MH continue. Comp and ConFM de-energize.

Defrost Termination: DTh warms to 40°F (4.4°C). EvapFM and MH continue. Comp and ConFM energize. 2-minute temperature display delay timer starts. 2 minutes later, cabinet temperature appears on DM.

Defrost Diagnosis:

Defrost Initiation: Has DTh cooled to 8.6°F (-13°C) or lower? Confirm DTh status. See "IV.C. Thermistor Check." If DTh is in proper range, confirm that Comp and ConFM de-energize. If not, check for 115VAC between CM C1 and CM N5. If 115VAC is present and DTh is within proper range, CM is defective and must be replaced. If there is no voltage between CM C1 and CM N5 and Comp and ConFM do not de-energize, check for 115VAC between CR terminal 4 and neutral. If 115VAC is present between CR terminal 4 and neutral, CR is defective and must be replaced.

Defrost Termination: Has DTh warmed to 40°F (4.4°C)? If not yet confirmed, confirm DTh status. See "IV.C. Thermistor Check." If DTh is in proper range, has Comp and ConFM energized? If not, check for 115VAC between CM C1 and CM N5. If 115VAC is not present, CM is defective and must be replaced. If 115VAC is present between CM C1 and CM N5, check for 115VAC on CR coil (terminals 5 and 6). If 115VAC is not present between CR 5 and CR 6, check continuity of HPS. If open, allow time for HPS to reset. If HPS does not reset, replace HPS and diagnose reason for HPS activation. See "IV.A.1.7)c) HPS Activation." If 115VAC is present between CR 5 and CR 6, and Comp and ConFM are not energized, check for 115VAC between CR terminal 4 and neutral and CR terminal 1 and neutral. If 115VAC is present between CR terminal 4 and neutral and not CR terminal 1 and neutral, CR is defective and must be replaced. If CR is good and Comp or ConFM are not energized, check for 115VAC at Comp terminals, Comp overload (integrated with start relay), start components, and Comp and ConFM motor winding continuity. 2-minute temperature delay timer terminates, temperature display appears on DM.

10) **MH Diagnosis:** Check that MH energizes. Check for 115VAC at MH. If 115VAC is not present, check power supply and continuity of power switch. If 115VAC is present, check amp draw of MH. If an amp reading is not present, check the continuity of MH.

Legend: **CM**—control module; **Comp**—compressor; **ConFM**—condenser fan motor; **CR**—compressor relay; **CTh**—cabinet thermistor; **DM**—display module; **DS**—door switch; **DSR**—door switch relay; **DTh**—defrost thermistor; **EvapFM**—evaporator fan motors; **HPS**—high-pressure switch; **MH**—mullion heater; **TXV**—thermostatic expansion valve

2. Freezer

- 7) **Startup/Cool Down**—MH and PH energize. There is a slight delay, then Comp, ConFM, and EvapFM energize and cabinet temperature or high-temperature alarm (Hi) appears on DM. Once DTh reaches 32°F (0°C), 4-hour Comp cumulative run timer starts.
- a) **Startup Diagnosis:** Check that EvapFM energize. If not, confirm that the door(s) are closed and DS contacts are closed. Check EvapFM blades for binding. Next, check for 115VAC at DSR terminals 7 and 8. If 115VAC is not present, check DS continuity. If 115VAC is present, check DSR coil continuity and contact continuity between terminals 6 and 4. If coil or contacts are open, DSR is bad and must be replaced. Next, check for 115VAC between CM F6 and CM N5. If 115VAC is not present, check between CM L3 and CM N5. If 115VAC is present between CM L3 and CM N5 and not between CM F6 and CM N5, CM is defective and must be replaced. If 115VAC is present between CM F6 and CM N5, check EvapFM continuity.
- b) **Cool Down Diagnosis:** Confirm that Comp and ConFM energize and cabinet temperature appears on DM. If not, confirm 115VAC between CM L3 and CM N5. If 115VAC is not present, confirm wiring connections are secure for both the power wire (CM L3) and the neutral wire (CM N5). If 115VAC is present and DM is off, check that the display cable between CM and DM is not disconnected; reconnect if loose. If DM is still off, CM or DM may be bad, so replace both. Next, check that Comp and ConFM are energized. If not, check for 115VAC between CM C1 and CM N5. If 115VAC is present between CM L3 and CM N5 (above) and not between CM C1 and CM N5, check CTh status. See "IV.C.Thermistor Check." If CTh ohm reading is in proper range, CM is bad and must be replaced. If 115VAC is present between CM C1 and CM N5, check for 115VAC on CR coil (terminals 5 and 6). If 115VAC is not present between CR 5 and CR 6, check continuity of HPS. If open, allow time for HPS to reset. If HPS does not reset, replace HPS and diagnose reason for HPS activation. See "IV.A.2.7)c) HPS Activation." If 115VAC is present between CR 5 and CR 6, and Comp and ConFM are not energized, check for 115VAC between CR terminal 4 and neutral and CR terminal 1 and neutral. If 115VAC is present between CR terminal 4 and neutral and not CR terminal 1 and neutral, CR is defective and must be replaced. If CR is good and Comp or ConFM are not energized, check for 115VAC at Comp terminals, Comp overload (internal on 1-section, external on 2-section), start components, and Comp and ConFM motor winding continuity.

If Comp and ConFM are energized and the cabinet does not cool down, check for a restriction in the refrigeration circuit, correct TXV operation, and correct refrigerant charge.

- c) **HPS Activation:** Confirm ConFM is energized and fan blade turns freely. Check that the condenser coil is not clogged or restricted. Check that there are no restrictions in the refrigeration circuit (drier, TXV).

Confirm that the location meets factory requirements:

- This unit is not intended for outdoor use. Normal operating ambient temperature should be within 45°F to 100°F (7°C to 38°C).
 - The unit should not be located next to ovens, grills, or other high heat producing equipment.
 - The unit should not be located in a corrosive environment.
 - The unit should be a minimum of 4" (11 cm) from side walls.
 - A minimum of 10" (25 cm) overhead clearance should be provided for proper ventilation.
- 8) **Cool Down Achieved**—CTh cools to 3°F (1.7°C) below setpoint. EvapFM, MH, and PH continue. Comp and ConFM de-energize. **Diagnosis:** If Comp and ConFM do not de-energize, confirm CTh status. See "IV.C. Thermistor Check." If CTh ohm reading is in proper range and Comp and ConFM do not de-energize, CM is defective and must be replaced.

9) **Defrost**

Temperature/Time-Initiated Defrost: Once DTh cools to 32°F (0°C), a 4-hour cumulative Comp run timer starts. Once DTh is at or below 32°F (0°C) and 4-hour cumulative Comp run timer terminates, MH and PH continue, DH energizes, and Comp, ConFM, and EvapFM de-energize. *Defrost Termination:* DTh warms to 59°F (15°C). MH and PH continue. DH de-energizes. 3-minute Comp delay timer starts, 8-minute EvapFM delay timer starts (3-minutes on manually initiated defrost), and 13-minute temperature display delay timer starts.

3-minute Comp delay timer terminates, Comp and ConFM energize. 5 minutes later, 8-minute EvapFM delay timer terminates and EvapFM energizes. 5 minutes after that, 13-minute temperature display delay timer terminates and cabinet temperature appears on DM.

Defrost Diagnosis:

Defrost Initiation: Has DTh cooled to 32°F (0°C) or lower? Confirm DTh status. See "IV.C. Thermistor Check." Has 4-hour Comp cumulative run timer satisfied. Check that Comp, ConFM, and EvapFM de-energize. If not, check for 115VAC between CM C1 and CM N5, then between CM F6 and CM N5. If 115VAC is present, CM is defective and must be replaced. If there is no voltage between CM C1 and CM N5 and Comp and ConFM do not de-energize, check for 115VAC between CR terminal 1 and neutral. If 115VAC is present between CR terminal 1 and neutral, CR is defective and must be replaced. Confirm DH energizes. If not, check for 115VAC between CM H4 and CM N5. If 115VAC is not present and DTh is in proper range, CM is defective and must be replaced. If 115VAC is present, confirm DH thermostat continuity, DH amp draw, and DH continuity.

Defrost Termination: Has DTh warmed to 59°F (15°C)? If not yet confirmed, confirm DTh status. See "IV.C. Thermistor Check." If DTh is good but defrost termination temperature is not reached, confirm DH amp draw and continuity. If DTh is good and defrost termination temperature is reached, DH de-energizes and 3 delay timers start.

3-minute Comp delay timer terminates: Have Comp and ConFM energized after DH is de-energized for 3 minutes? If not, check for 115VAC between CM C1 and CM N5. If 115VAC is not present, CM is defective and must be replaced. If 115VAC is present between CM C1 and CM N5, check for 115VAC on CR coil (terminals 5 and 6). If 115VAC is not present between CR 5 and CR 6, check continuity of HPS. If open, allow time for HPS to reset. If HPS does not reset, replace HPS and diagnose reason for HPS activation. See "IV.A.2.7)c) HPS Activation." If 115VAC is present between CR 5 and CR 6, and Comp and ConFM are not energized, check for 115VAC between CR terminal 4 and neutral and CR terminal 1 and neutral. If 115VAC is present between CR terminal 4 and neutral and not CR terminal 1 and neutral, CR is defective and must be replaced. If CR is good and Comp or ConFM are not energized, check for 115VAC at Comp terminals, Comp overload (internal on 1-section, external on 2-section), start components, and Comp and ConFM motor winding continuity.

8-minute EvapFM delay timer terminates (3-minutes on manually initiated defrost): Have EvapFM energized 5 minutes after Comp and ConFM energized? If not, confirm that the door(s) are closed and DS contacts are closed. Check EvapFM blades for binding. Next, check for 115VAC at DSR terminals 7 and 8. If 115VAC is not present, check DS continuity. If 115VAC is present, check DSR coil continuity and contact continuity between terminals 6 and 4. If coil or contacts are open, DSR is bad and must be replaced. Next, check for 115VAC between CM F6 and CM N5. If 115VAC is not present, check between CM L3 and CM N5. If 115VAC is present between CM L3 and CM N5 and not between CM F6 and CM N5, CM is defective and must be replaced. If 115VAC is present between CM F6 and CM N5, check EvapFM continuity.

13-minute temperature display delay timer terminates: Confirm cabinet temperature appears on DM 5 minutes after EvapFM energizes.

If components fail to start after delay timer terminates, CM is defective and must be replaced.

- 10) **MH and PH Diagnosis:** Check that MH and PH energize. Check for 115VAC at MH and PH. If 115VAC is not present, check power supply and continuity of power switch. If 115VAC is present, check amp draw of MH or PH. If an amp reading is not present, check the continuity of MH or PH.

Legend: **CM**—control module; **Comp**—compressor; **ConFM**—condenser fan motor; **CR**—compressor relay; **CTh**—cabinet thermistor; **DH**—defrost heater; **DM**—display module; **DSR**—door switch relay; **DTh**—defrost thermistor; **EvapFM**—evaporator fan motors; **HPS**—high-pressure switch; **MH**—mullion heater; **PH**—perimeter heater; **TXV**—thermostatic expansion valve

B. Control Module Check

Before replacing a control module that does not show a visible defect and that you suspect is bad, always conduct the following check procedure. This procedure will help you verify your diagnosis. Always choose a white (W) neutral wire to establish a good neutral connection when checking high voltages. Also, confirm that there is a good neutral connection to the control module terminal N5.

Alarm Reset: To silence the alarm, press and release the upper or lower button with power on. For alarm information, see "II.D.2. Alarm Safeties."

Startup/Cool Down:

- 1) Check all wiring connections. Confirm that the display module cable, cabinet thermistor, and defrost thermistor are properly connected.
- 2) Move the power switch to the "ON" position.
- 3) Check for 115VAC between control module terminals L3 and N5. If 115VAC is not present, check power supply and power switch.
- 4) Check that the display module is on and cabinet temperature is displayed. If not, it is recommended that both the control module and display module be replaced.
- 5) Freezer: Check that the evaporator fan motors are energized. Make sure that the door(s) are closed and the door switch is engaged. Next, check for 115VAC between control module terminals F6 and N5. If 115VAC is not present, the control module must be replaced.
- 6) Check that the compressor and condenser fan motor energize. If not, check for 115VAC between control module terminals C1 and N5. If 115VAC is not present, control module must be replaced.

Defrost:

- 7) Press and hold the lower button until "dEF" appears on the display module.
- 8) Confirm that the compressor, condenser fan motor, and evaporator fan motors (freezer) de-energize. Check for 115VAC between control module terminals C1 and N5 for compressor and condenser fan motor, then between terminals F6 and N5 (freezer) for evaporator fan motors. If "dEF" is displayed and there is 115VAC between the terminals, control module must be replaced.
- 9) Freezer: Confirm that the defrost heater energizes. Check for 115VAC between control module terminals H4 and N5. If "dEF" is displayed and 115VAC is not present, control module must be replaced.
- 10) Check that the components restart after defrost termination.

Refrigerator: Compressor and condenser fan motor energize as soon as the defrost thermistor termination temperature is satisfied. See "*Defrost Termination*" under "IV.A.1.9) Defrost" and "IV.C. Thermistor Check." If components fail to start, control module must be replaced.

Freezer: Compressor and condenser fan motor energize 3-minutes after defrost termination temperature is satisfied. Evaporator fan motor energizes 5-minutes after that (except manual defrost), and the cabinet temperature appears on the display module 5-minutes after the evaporator fan motor energizes. See "*Defrost Termination*" under

"IV.A.2.9) Defrost" and "IV.C. Thermistor Check." If components fail to start, control module must be replaced.

C. Thermistor Check

In the event the cabinet thermistor reading is out of range (E1 alarm), the compressor operates on a fixed time basis of 5-minutes on and 5-minutes off.

In the event the refrigerator defrost thermistor reading is out of range (E2 alarm), defrost initiation occurs every 4-hours of cumulative compressor run time and terminates on 20-minute minimum defrost timer.

In the event the freezer defrost thermistor reading is out of range (E2 alarm), defrost initiation occurs every 4-hours of cumulative compressor run time and terminates based on cabinet thermistor temperature.

To check thermistor resistance, follow the steps below.

- 1) Move the power switch to the "OFF" position, then unplug the unit.
- 2) Remove the control box cover.
- 3) Disconnect and remove the thermistor in question.
- 4) Immerse the thermistor sensor portion in a glass containing ice and water for 2 to 3 minutes.
- 5) Check the resistance between the wires at the thermistor connector. Normal reading is within 16.0 to 16.7 k Ω . If outside the normal reading, replace the thermistor.
- 6) Reconnect and replace the thermistor in its correct position. See "V.B. Important Notes for Component Replacement."
- 7) Plug the unit back in. Move the power switch to the "ON" position.

D. Diagnostic Chart

Before consulting the diagnostic charts, check the following:

- Check the setpoint. For factory default settings, see "II.C.2.a) Default Settings."
- Make sure the doors are not left open or opened too often and that they are sealing properly.
- Make sure the cabinet is not overloaded with warm or hot product or product blocking airflow. Product should be allowed to cool before putting in the unit.
- Check for correct installation and proper voltage per unit nameplate. This unit is not intended for outdoor use. Normal operating ambient temperature should be within 45°F to 100°F (7°C to 38°C). The unit should not be located next to ovens, grills, or other high heat producing equipment. The unit should be a minimum of 4" (11 cm) from side walls and a minimum of 10" (25 cm) overhead clearance should be provided for proper ventilation.
- Check the control module using the steps in "IV.B. Control Module Check."

1. Unit Not Cooling

Unit Not Cooling - Possible Cause	
1. Power Supply	a) Unplugged, off, blown fuse, or tripped or defective circuit breaker. On three-section receptacle box, only top receptacles have power.
	b) Loose connection.
	c) Not within specifications.
2. Cord and Plug On three-section model, check receptacle box cord and plug and one-section and two-section cords and plugs.	a) Loose connection.
	b) Defective.
3. Power Switch (control box)	a) "OFF" position.
	b) Bad contacts.
4. Wiring	a) Loose connection or open.
	b) Faulty.
5. Control Module See "II.D.2. Alarm Safeties" and "IV.B. Control Module Check."	a) In alarm or "- - -" displayed.
	b) Defective.
6. Door Switch	a) Defective.
7. Door Switch Relay	a) Loose connection.
	b) Bad contacts.
	c) Open coil windings.
8. Evaporator Fan Motor	a) Defective.
9. High-Pressure Switch	a) Dirty condenser.
	b) Ambient temperature too warm.
	c) Condenser fan not operating.
	d) Refrigerant overcharge.
	e) Refrigerant lines or components restricted.
	f) Bad contacts.
10. Compressor Relay	a) Bad contacts.
	b) Open coil windings.

Unit Not Cooling - Possible Cause	
11. Compressor Overload	a) Dirty condenser.
	b) Condenser fan not operating.
	c) Defective.
12. Compressor	a) Defective.
13. Condenser	a) Dirty.
14. Evaporator See "2. Evaporator is Frozen Up."	a) Clogged or frozen.
15. Refrigerant/Refrigerant Lines	a) Gas leak.
	b) Refrigerant lines restricted.

2. Evaporator is Frozen Up

Evaporator is Frozen Up - Possible Cause	
1. Evaporator	a) Dirty.
2. Evaporator Fan	a) Not operating.
3. Defrost Thermistor	a) Out of position or defective.
4. Control Module	a) Defective.
5. Refrigerant Charge	a) Low.
6. Defrost Heater (freezer)	a) Defective.
7. Defrost Thermostat Open (freezer)	a) Defective.

3. Defrost Fails to Terminate

Defrost Fails to Terminate - Possible Cause	
1. Defrost Thermistor	a) Out of position or defective.
2. Control Module	a) Defective.

V. Replacement of Components

⚠ WARNING

1. This unit should be diagnosed and repaired only by qualified service personnel to reduce the risk of death, electric shock, serious injury, or fire.
2. Move the power switch to the "OFF" position, then unplug the unit from the electrical outlet before servicing.
3. Make sure all food zones in the icemaker and storage bin are clean after the unit is serviced. For cleaning procedures, see "VI. Cleaning and Maintenance Instructions."

A. Service for Refrigerant Lines

⚠ WARNING

1. Repairs requiring the refrigeration circuit to be opened must be performed by properly trained and EPA-certified service personnel.
2. Always recover the refrigerant and store it in an approved container. Do not discharge the refrigerant into the atmosphere.
3. Use an electronic leak detector or soap bubbles to check for leaks. Add a trace of refrigerant to the system (if using an electronic leak detector), and then raise the pressure using nitrogen gas (140 PSIG). DO NOT use R-134a or R-404A as a mixture with pressurized air for leak testing.

CAUTION

1. Do not leave the system open for longer than 15 minutes when replacing or servicing parts. The Polyol Ester (POE) oils used in R-134a and R-404A units can absorb moisture quickly. Therefore it is important to prevent moisture from entering the system when replacing or servicing parts.
2. Always install a new drier every time the sealed refrigeration system is opened.
3. Do not replace the drier until after all other repair or replacement has been made. Install the new drier with the arrow on the drier in the direction of the refrigerant flow.
4. When brazing, protect the drier by using a wet cloth to prevent the drier from overheating. Do not allow the drier to exceed 250°F (121°C).

1. Refrigerant Recovery

The unit is provided with refrigerant access valves. Using proper refrigerant practices recover the refrigerant from the access valves and store it in an approved container. Do not discharge the refrigerant into the atmosphere.

2. Brazing

⚠ WARNING

1. R-134a and R-404A themselves are not flammable at atmospheric pressure and temperatures up to 176°F (80°C).
2. R-134a and R-404A themselves are not explosive or poisonous. However, when exposed to high temperatures (open flames), R-134a and R-404A can be decomposed to form hydrofluoric acid and carbonyl fluoride both of which are hazardous.
3. Do not use silver alloy or copper alloy containing arsenic.
4. Use an electronic leak detector or soap bubbles to check for leaks. Add a trace of refrigerant to the system (if using an electronic leak detector), and then raise the pressure using nitrogen gas (140PSIG). DO NOT use R-134a or R-404A as a mixture with pressurized air for leak testing.

- 1) Braze all fittings while purging with nitrogen gas flowing at a pressure of 3 to 4 PSIG.

⚠ CAUTION

1. Always install a new drier every time the sealed refrigeration system is opened.
2. Do not replace the drier until after all other repair or replacement has been made. Install the new drier with the arrow on the drier in the direction of the refrigerant flow.
3. When brazing, protect the drier by using a wet cloth to prevent the drier from overheating. Do not allow the drier to exceed 250°F (121°C).

- 2) Use an electronic leak detector or soap bubbles to check for leaks. Add a trace of refrigerant to the system (if using an electronic leak detector), and then raise the pressure using nitrogen gas (140 PSIG). DO NOT use R-134a or R-404A as a mixture with pressurized air for leak testing.

3. Evacuation and Recharge

- 1) Attach a vacuum pump to the system. Be sure the charging hoses are connected to both high and low-side access valves.

⚠ IMPORTANT

The vacuum level and vacuum pump may be the same as those for current refrigerants. However, the rubber hose and gauge manifold to be used for evacuation and refrigerant charge should be exclusively for POE oils.

- 2) Turn on the vacuum pump. Open the gauge manifold valves. Never allow the oil in the vacuum pump to flow backwards.
- 3) Allow the vacuum pump to pull down to a 29.9" Hg vacuum. Evacuating period depends on pump capacity.

- 4) Close the low-side valve and high-side valve on the gauge manifold.
- 5) Disconnect the gauge manifold hose from the vacuum pump and attach it to a refrigerant service cylinder. Remember to loosen the connection and purge the air from the hose. See the nameplate for the required refrigerant charge. Hoshizaki recommends only virgin refrigerant or reclaimed refrigerant which meets ARI Standard 700 (latest edition) be used.
- 6) A liquid charge is required when charging an R-404A system (to prevent fractionation) and optional when charging an R-134a system. Place the service cylinder on the scales; if the service cylinder is not equipped with a dip tube, invert the service cylinder, then place it on the scales. Open the high-side valve on the gauge manifold.
- 7) Allow the system to charge with liquid until the proper charge weight is met.
- 8) If necessary, add any remaining charge to the system through the low-side.
CAUTION! To prevent compressor damage, use a throttling valve or liquid dispensing device to add the remaining liquid charge through the low-side access valve with the unit running.
- 9) Close gauge manifold valves and disconnect the hoses.
- 10) Cap the access valves to prevent a possible leak.

B. Important Notes for Component Replacement

CAUTION

When replacing a component listed below, see the notes to help ensure proper operation.

Component	Notes
Compressor	Install a new start relay, start capacitor, and compressor overload (compressor overload is integrated with the start relay on refrigerators; internal on 1-section freezers; external on 2-section freezers).
Compressor, Evaporator Fan Motor, Condenser Fan Motor	WARNING! To reduce the risk of electric shock, be sure to reconnect the component's ground wire.
Expansion Valve	<ul style="list-style-type: none"> • Attach the expansion valve bulb to the suction line in the same location as the previous bulb. • Secure the bulb with the clamp and holder, then insulate it.
Defrost Thermistor	After working with or around the defrost thermistor on a freezer, make sure the defrost thermistor wire is not touching the defrost heater.
Control Module	<p>If three dashes (- - -) appear on the display module when energized, the compressor and display module are off. To turn the compressor and display module on, press and hold the upper and lower buttons until the temperature appears on the display. CAUTION! The three dashes must be cleared, otherwise the compressor will not run and product will be lost.</p> 

C. Door Re-Hinging

This unit is provided with a cabinet design which, after being delivered to the installation location, permits changing of the door swing from left to right or right to left. To change the door swing, an HS kit from your local Hoshizaki distributor is required. See the table below. **CAUTION! Improper installation of the HS kit may result in the doors not closing completely and/or the gaskets not sealing correctly.** For further details, contact your local Hoshizaki distributor or Hoshizaki Technical Support at 1-800-233-1940.

Convert	HS Kit Number
Right Hinge to Left Hinge	HS-3725
Left Hinge to Right Hinge	HS-3726

VI. Cleaning and Maintenance Instructions

A. Cleaning

⚠ WARNING

1. Before cleaning the unit, move the power switch to the "OFF" position and unplug the unit to prevent electric shock by unexpected entrance of water into the unit or injury by moving parts.
2. Before cleaning the unit, move all foods into another clean refrigerator or freezer.
3. Do not splash water directly onto the unit. This might cause short circuit, electric shock, corrosion, or failure.
4. Before using a sanitizer such as inert soap and sodium hypochlorite (chlorine bleach), thoroughly read the manufacturer's instructions on its proper usage.

IMPORTANT

1. To prevent damage to the plastic surfaces, do not use the following: thinner, benzine, alcohol, petroleum, soap powder, polishing powder, alkaline cleaner, acid, scouring pad and especially those strong cleaners for use on a ventilating fan or a cooking range. Also, to prevent corrosion, do not use sodium hypochlorite (chlorine bleach) on the stainless steel surfaces.
2. Use a clean cloth for cleaning.

1. Exterior

Wipe the exterior occasionally with a clean, soft cloth. Use a damp cloth containing a neutral cleaner to wipe off oil or dirt buildup.

2. Cabinet Interior

Spills should be wiped up promptly to avoid unpleasant odors. The cabinet interior should be cleaned periodically with a mild soap or detergent and warm water.

3. Door Gaskets

Door gaskets should be cleaned regularly with mild soap and warm water to remove dirt and grease.

4. Shelves

Remove and clean regularly.

B. Maintenance

1. Condenser

Check the condenser once a year and use a brush or vacuum cleaner to clean the condenser as required.

2. Power Supply Connection

If a plug, power cord, or receptacle (three-section models) is damaged, replace it. Be sure to connect the ground wire.

C. Shutdown and Long Storage

⚠ WARNING

1. When preparing the unit for long storage, prevent the doors from closing to reduce the risk of children getting trapped.
2. To reduce the risk of electric shock, do not touch the attachment plug or power switch with damp hands.
3. 115V Units: To unplug the unit, be sure to pull the plug and do not jerk the power cord. It could be damaged and cause fire or electric shock.
4. 208-230V Units: To unplug the unit, twist the plug counter-clockwise, then pull the plug and do not jerk the power cord. It could be damaged and cause fire or electric shock.
5. When shutting down the unit for more than one week, move the power switch to the "OFF" position and unplug the unit.
6. Do not plug in/unplug the unit to start/stop operation. Make sure the power switch is in the "OFF" position before plugging in or unplugging the unit to reduce the risk of electric shock.

- 1) Before shutting down the unit, move the stored food into another refrigerator.
- 2) Reach over the front panel and move the power switch to the "OFF" position. The unit will shut down.
- 3) Unplug the unit. Before unplugging a 4-prong plug, rotate the plug counter-clockwise to unlock it.

IMPORTANT

When preparing the unit for long storage, clean the cabinet interior, door gaskets, and shelves. See "VI.A. Cleaning" for details.