

**I
N
S
T
R
U
C
T
I
O
N
S**

**MODEL PCN90 SERIES
ELECTRIC CONVECTION OVENS**

PCN90 ML-43719



EXECUTIVE OFFICES
TROY, OHIO 45374

- THIS PAGE INTENTIONALLY LEFT BLANK -

Installation, Operation and Care of PCN90 SERIES ELECTRIC CONVECTION OVENS

SAVE THESE INSTRUCTIONS

GENERAL

The PCN90 Series electric convection ovens feature Perfect Touch™ programmable controls. Each oven is equipped with a 1/3 h.p. motor.

The Model PCN901 is a single oven which is furnished with a set of four 25³/₄" adjustable stainless steel legs.

The Model PCN902 consists of two single PCN90 ovens, a set of four 8" adjustable stainless steel legs, and a stack set for mounting one oven on top of the other.

The Model PCN902 is a single PCN90 oven furnished with a storage stand on four 6" adjustable stainless steel legs.

Accessories available include additional racks and a removable stainless steel liner kit.

INSTALLATION

UNPACKING

Immediately after unpacking, check the oven for possible shipping damage. If the oven is found to be damaged, save the packaging material and contact the carrier within 15 days of delivery.

Prior to installation, test the electrical service to be sure that it agrees with the specifications on the oven data plate.

INSTALLING SINGLE OVENS

Installing Basic Oven (PCN90)

The basic oven must be installed on legs or be mounted on a modular stand. Installations on concrete bases or other supports restricting air circulation on the bottom will void the warranty. If using the modular stand, set the oven on the stand after uncrating.

Assembling the Legs to the Oven (PCN901)

1. Position the oven on its back, taking care not to scratch the sides.
2. Attach the four leg assemblies to the bottom of the oven with the twenty-four bolts and lockwashers.
3. Reposition the oven by setting it on its legs in the installed position.

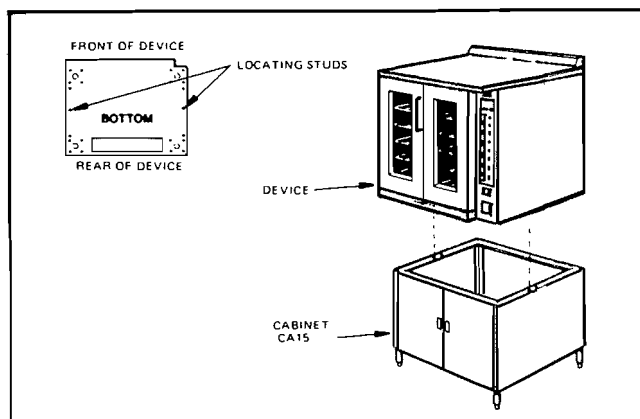

Fig. 1 — Installation of basic oven on cabinet — (procedures identical for installing open stand, CX286).

Assembling Cabinet Base or Stand (PCN903)

1. Screw two locating studs (found in cabinet base or stand carton) into bottom of oven (Fig. 1).
2. Mount the oven on top of the stand or cabinet (Fig. 1).

Assembling the Chimney and Flue Extension

Remove the oven chimney and flue extension from the rear of the oven (motor compartment) and use the screws provided to fasten the chimney to the top rear of the oven. **NOTE:** The flanges on the chimney are to be positioned under the top cover. Also attach the flue extension.

Electrical Connections

WARNING: ELECTRICAL AND GROUNDING CONNECTIONS MUST COMPLY WITH THE APPLICABLE PORTIONS OF THE NATIONAL ELECTRICAL CODE AND/OR OTHER LOCAL ELECTRICAL CODES.

WARNING: DISCONNECT ELECTRICAL POWER SUPPLY AND PLACE A TAG AT THE DISCONNECT SWITCH TO INDICATE THAT YOU ARE WORKING ON THE CIRCUIT.

Assure that the electrical supply agrees with the specifications on the oven data plate.

Open the door of the wiring compartment cover by pushing the button on the front of the oven (the lower portion of the control panel). Remove the appropriate knock-out on the bottom of the oven and attach the power supply conduit to the bottom of the oven.

Comply with the appropriate wiring diagram attached to the oven when making connections to the electrical supply lines.

Replace the wiring compartment cover, and energize the power supply.

ELECTRICAL DATA

	TOTAL KW	3 PHASE LOADING (KW PER PHASE) 208-240V			NOMINAL AMPS PER LINE WIRE							
					3 PHASE						1 PHASE	
		L1-L2	L2-L3	L1-L3	208V.			240V.			208V.	240V.
					L1	L2	L3	L1	L2	L3		
SINGLE OVEN	11	3.35	3.35	4.30	32.0	27.9	32.0	27.7	24.2	27.7	52.8	45.8
STACKED OVEN	22	6.70	6.70	8.60	64.0	55.8	64.0	55.4	48.4	55.4	105.6	91.6

The 208 & 240 volt ovens covered by this manual are for connection to a 1 or 3 phase power system. Ovens leaving the factory are wired for connection to a 3 phase power system. Wires can be changed at the installation site for connection to a 1 phase power system by altering the wiring at the terminal block.

Leveling

Adjust the legs to assure that the oven racks are level in the final installed position.

INSTALLING DOUBLE OVENS

Assembling Stacked Ovens (PCN902)

1. Position one oven on its back for access to the oven bottom, taking care not to scratch the sides. Attach the four leg assemblies with the twenty-four bolts and lockwashers provided.
2. Place the lower oven (with legs) on the floor and remove the two $\frac{7}{16}$ " diameter knock-outs on each side of the top cover plus the $1\frac{3}{8}$ " diameter knock-out at the right front of the top cover.
3. Install the two locating studs (included in the leg stack set) into the screw plates on the under side of the upper oven. (See Fig. 1).
4. Remove oven chimneys stored at the rear of both ovens. Discard one chimney. Attach the remaining chimney to the top of the upper oven (oven without legs). **NOTE:** The flanges on the chimney are to be positioned under the top cover.
5. Move the oven with legs to the installed position and place the upper oven on top of the lower oven using the locating studs. Open the doors of the wiring compartment covers by pushing the button on the front of both ovens. Also unfasten the control panel (of the lower oven only) and carefully pull forward. This will facilitate routing the power leads (furnished) to the top oven, as well as attaching the one-inch conduit nipple and lock nut (also furnished).
6. Attach the short flue extension over the exhaust vent at the rear of the upper oven. Slide the long flue extension tube over the exhaust vent at the rear of the lower oven. These extensions should direct the exhaust fumes upward through and above the top oven.
7. Place the 1" conduit nipple through the $1\frac{3}{8}$ " hole in the bottom of the top oven and the top of the bottom oven and clamp the two ovens together with the locknut from the underside.

Electrical Connections

WARNING: ELECTRICAL AND GROUNDING CONNECTIONS MUST COMPLY WITH THE APPLICABLE PORTIONS OF THE NATIONAL ELECTRICAL CODE AND/OR OTHER LOCAL ELECTRICAL CODES.

WARNING: DISCONNECT ELECTRICAL POWER SUPPLY AND PLACE A TAG AT THE DISCONNECT SWITCH TO INDICATE THAT YOU ARE WORKING ON THE CIRCUIT.

Assure that the electrical power supply agrees with the specifications on the oven data plate and complies with the wiring diagram on the oven.

1. Attach the power leads to the line side of the terminal block of the upper oven. Then carefully route these leads (furnished as part of the stack set) down through the conduit nipple and behind the control panel of the lower oven.
2. Attach these leads to the lower oven terminal block per the wiring diagram. At the same time, attach the power supply conduit to the bottom of the lower oven. Also attach the power supply leads to the line side of the terminal block.
3. Finally, inspect and check all wiring and terminal connections for tightness and proper routing away from any moving parts (relay solenoid core), or pinch points (cover on oven frame). Then carefully replace the lower oven control panel and wiring compartment covers for both ovens.

ELECTRICAL DATA

	TOTAL KW	3 PHASE LOADING (KW PER PHASE) 208-240V			NOMINAL AMPS PER LINE WIRE							
					3 PHASE						1 PHASE	
		L1-L2	L2-L3	L1-L3	208V.			240V.			208V.	240V.
					L1	L2	L3	L1	L2	L3		
SINGLE OVEN	11	3.35	3.35	4.30	32.0	27.9	32.0	27.7	24.2	27.7	52.8	45.8
STACKED OVEN	22	6.70	6.70	8.60	64.0	55.8	64.0	55.4	48.4	55.4	105.6	91.6

The 208 & 240 volt ovens covered by this manual are for connection to a 1 or 3 phase power system. Ovens leaving the factory are wired for connection to a 3 phase power system. Wires can be changed at the installation site for connection to a 1 phase power system by altering the wiring at the terminal block.

Leveling

Adjust the legs to assure that the oven racks are level in the final installed position.

INSTALLING OPTIONAL LINER KITS

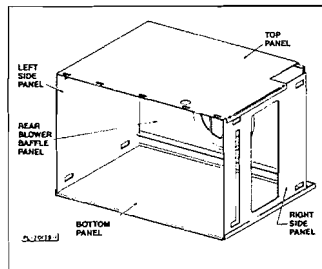

Fig. 2 — Contents of CX581 stainless steel liner kit for standard 36" deep convection ovens.

The CX581 liner kit components are identified above. Please follow the sequence shown below to install.

Steps to Adding Panels

WARNING: DISCONNECT ELECTRICAL POWER AND PLACE A TAG AT THE DISCONNECT SWITCH TO INDICATE THAT YOU ARE WORKING ON THE CIRCUIT.

IMPORTANT: Remove all protective lining material from stainless steel panels prior to installation.



Fig. 3



Fig. 4

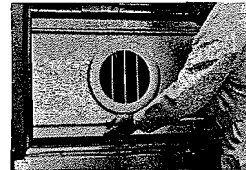

Fig. 5

Remove all racks by pushing down slightly on front of rack top to disengage the positive rack rear lock. When rack back is raised to clear, pull straight out as shown in Fig. 3.

Remove both left and right rack guides by lifting them straight up, tilting the bottom of the guides toward the oven center, and pulling out as shown in Fig. 4.

Remove aluminized steel back blower baffle by lifting straight up, then pulling forward and out. Tilt slightly from left to right to clear side brackets as shown in Fig. 5. Discard this blower baffle.

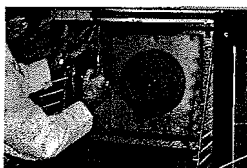

Fig. 6



Fig. 7



Fig. 8



Fig. 9

Install top panel by inserting screws (3 screws in front, 2 in back) and screwing tightly to top of oven interior as shown in Fig. 6.

Install new back blower baffle by tilting the panel slightly from left to right to clear the side rack guide brackets as shown in Fig. 7. Then press panel up against the oven's back interior. Lift and lower panel until it rests on blower baffle supports. No screws are required.

Install bottom panel by lifting over rack guide brackets and pushing straight in as shown in Fig. 8.

Install left and right side panels placing the cut-out notches over light bank (right panel), thermostat guard (right panel) and rack guide support brackets (right and left panels), Fig. 9.

Reassembling Rack Guides and Racks

Reassemble the left and right rack guides by inserting them in support brackets (reverse procedure in Fig. 4). Insert racks in rack guides (reverse procedure in Fig. 3).

OPERATION

BEFORE FIRST USE

Before the oven is used for the first time, it must be "burned in" to release any odors that might result from heating the new surfaces in the chamber.

Using a clean damp cloth, wipe the inside of the oven, including the racks.

Wipe the outer surfaces to remove any dirt or film that may have accumulated during shipment.

Close the oven door, turn the oven ON, and program one of the products for [TIME = 6:00:00; TEMP = 300°F; FAN = 2; CC = 0]. Start a cycle for this product button. Smoke with an unpleasant odor will normally be given off. When the display shows DONE, press the product button to cancel.

If your oven has the painted finish, apply a generous coat of wax or another hard glossy finish that will protect the painted surfaces.

CONTROLS

Become familiar with the location and function of the controls illustrated in Fig. 10 before programming the oven.

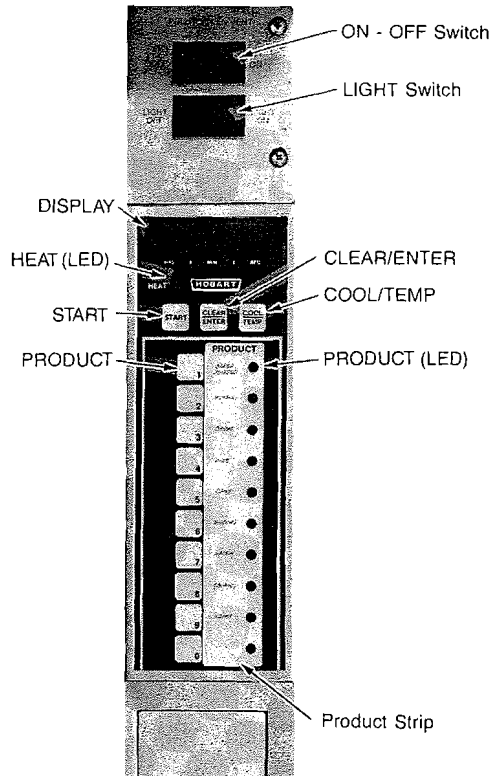

Fig. 10

PROGRAMMABLE CONTROLS

The maximum programmable temperature is 475° F. If the temperature in the oven should reach 500° F. the display will flash HIGH TEMP and a warning beeper will sound.

The maximum time that can be programmed is 19 hours, 59 minutes and 59 seconds.

There are 10 PRODUCT buttons (0-9) which may be programmed to automatically schedule one, two, three and/or four stages of cooking with **TEMP**erature, **TIME**, **FAN** and **Cooking Curve** setting for each stage. (**CC** is programmed on the first stage only but is in effect for all stages.)

- TEMP** — Degrees Fahrenheit or Centigrade
- TIME** — HHMMSS HH = Hours MM = Minutes SS = Seconds
- FAN** — 0 = Low Speed (during heat cycle), Otherwise Off
 - 1 = Low Speed Continuous
 - 2 = High Speed Continuous
- CC** — 0 - 15 = See Cooking Curve

COOKING CURVE (CC): A relationship between temperature and time. If the oven temperature drops below the set temperature for any reason, the control will compensate for that loss. The length of time between counts of the timed countdown will increase to compensate for the temperature loss. The higher the CC number selected the greater the increase. A cooking curve of "0" will not compensate for any change in temperature.

SUGGESTED CC SETTINGS

Baked potatoes	1 to 3
Beef roast	3 to 5
Pies	5 to 8
Bread, cake	6 to 9
Buttermilk biscuits	7 to 9
Muffins	8 to 10
Cookies	9 to 11
Bacon	12 to 13

Generally the more delicate items will require the higher CC settings.

MANAGER SECURITY

The program for each PRODUCT may be operator or manager programmed. A manager programmed product requires the 4 digit manager code [0123] to be entered before entering the program. Manager programmed products may not be changed or removed without first entering the 4 digit manager code.

SERVICE

If a condition exists which requires a service call, the display will flash **SRVICE** each time the oven is turned on or just before **ON** is displayed. Diagnosis and display of a problem will not interfere with the operation of the oven as long as the oven is operable. If the display reads **OPEN** or **SHORT**, the unit will not operate and an authorized servicer should be called.

PROGRAMMING MODE

Please read entire instruction before beginning programming mode.

With **ON/OFF** switch **ON** . . .

- DISPLAY**
1.
 2.

DO
Press **CLEAR ENTER**.

Within 4 seconds you must press a **PRODUCT** (0-9). If you wish to program a manager's **PRODUCT**, enter the Code [0123] prior to a **PRODUCT** (0-9).

Wait 5 seconds.

Programming Mode (Cont.)

DISPLAY

3.

4.

5.

6.

7.

8. flashes

(Program was saved.)

DO

Enter the time for the 1st stage. Time is entered right to left on display. For example: To enter 2 hours you must enter a 2 and 4 zeros.

Press START or wait 5 seconds.

Enter temperature for first stage.

Press START or wait 5 seconds.

Enter fan setting for first stage.

0 = Low Speed (during heating cycle), Otherwise Off

1 = Low Speed

2 = High Speed.

Press START or wait 5 seconds.

Enter the Cooking Curve (0-15).

Press START or wait 5 seconds.

If you wish to stop after this stage, press 0 and go to step 8.

Repeat TIME, TEMP and FAN settings for stages 2, 3 and/or 4 by repeating steps 3-5 as required. You may exit only at a TIME prompt.

The CC setting is entered on stage 1 only.

To enter another program press a PRODUCT (0-9). Go to step 3. To exit program mode press CLEAR.

If you make a mistake and wish to step backward through a program you may do so by pressing CLEAR/ENTER. When you have corrected your error you must step forward by pressing START. You must step through the entire program. If you exit by pressing "0" you will delete the remainder of the program.

If you wish to review a program that has already been entered.

9.

Press CLEAR/ENTER and PRODUCT to be reviewed.

Wait 5 seconds.

10.

Press START to step through the program. You must step through the entire program. If you press "0" to exit review, you will delete the remainder of the program.

If you wish to clear a PRODUCT program, simply press "0" at the TIME-1 prompt.

To clear a PRODUCT program that was entered with the manager code [0123], you must enter the manager code [0123].

PRODUCT STRIP: After you program a PRODUCT, you may identify the PRODUCT on the PRODUCT STRIP. Simply write directly on the strip with a permanent type felt tip marker or use labels which may be removed and replaced if products change.

NORMAL COOKING

With ON/OFF switch ON . . .

DISPLAY	DO
101. <input type="text" value="ON"/>	Press the number of the pre-programmed PRODUCT instruction (0-9).
102. <input type="text" value="PRE-HT"/> or <input type="text" value="COOLNG"/>	Wait for temperature to stabilize at the TEMP 1 setting. Go to 103. The LED of the PRODUCT selected will flash and other products with a TEMP-1 within 10 degrees will be lit.

Optional

Press COOL/TEMP (once) Press COOL/TEMP (twice) Press COOL/TEMP (3 times)	A XXXF = Actual temperature. S YYYYF = Set temperature. Returns to PRE-HT or COOLNG.
--	--

103. <input type="text" value="READY"/> "Beeper Sounds"	Load Product. Other lighted PRODUCT(s) may be selected since the preheat is satisfied. If you wish to cook one of these products, load and press that PRODUCT.
104. <input type="text" value="DOOR"/>	Close door.
105. <input type="text" value="READY"/>	Press START.
106. Countdown begins. <input type="text" value="HHMMSS"/>	

The total time for all stages programmed will be displayed and countdown begins. The normal interval between counts is one second, but the interval may change due to temperature variation and the selected cooking curve.

Compatible Products

Products are compatible if they have only one cooking stage which has the same temperature and same fan speed as the one-stage product being cooked. During the cooking cycle, compatible product LED'S will be lit. During the cooking cycle the door may be opened and one of these compatible products may be put in the oven and that PRODUCT number pressed. The display will flash "OK" if the product is compatible. If not, the display will flash NOT COMPAT. If the product is accepted, the shortest cooking time will be displayed. If the new product cooking time is less than the remaining time for the original product, the new time will be displayed and counted down. When the time expires and the beeper sounds, open the door and remove the new product, close the door and press CLEAR. The remaining time for the original product will be displayed and counted down.

Normal Cooking (Cont.)

Batch Processing

This feature allows you to bake several batches of the same product and stagger the loading and unloading. For example: PRODUCT 1 is programmed 10 minutes at 375°F with a fan speed of 2 and a CC of 9. Press PRODUCT 1. When preheat is satisfied and oven is ready, load product and press START. Prepare second batch, load second batch and press PRODUCT 1 again. The display will continue to countdown the original time until expired. When the original batch is removed, press CLEAR and the remaining time for batch 2 will countdown. The CC selection will compensate for temperature loss during loading and unloading. The number of batches is limited to twenty or by the oven capacity.

If you open the door, the timer freezes.
If you wish to cancel a program in process, press CLEAR/ENTER two times. s.

Optional . . . Timer continues to countdown.

Press COOL/TEMP (once)	A XXXF = Actual temperature.
Press COOL/TEMP (twice)	S YYYYF = Set temperature.
Press COOL/TEMP (3 times)	Returns to countdown HHMMSS.

107. Countdown ends.

DONE

"Beeper Sounds"

Unload product.

108.

DOOR

Close door.

To continue cooking mode, press CLEAR/ENTER, go to step 102.

To exit cooking mode, press CLEAR/ENTER two times.

LOADING

Press the PRODUCT for the program you want to select. When the display shows READY, open the door and load the oven as quickly as possible. Since the oven chamber is large and loading requires keeping the doors open, temperature drops will occur. The control uses cooking curves to adjust the cooking time, allowing for these drops. To minimize heat loss during loading, the doors should be open for the least amount of time. Close the door and press START.

RACK DATA (Pan Capacities Shown For Single Rack)

MODEL	NO. STD. RACKS	STD. RACK SPACING	NO. OPTIONAL RACKS	11 RACK SPACING	RACK SIZE	9" OD PIE TINS	#200 PANS	18" x 26" PANS
		IN.		IN.	IN.			
PCN901 PCN903	5	2.87	6	1.25	27.5 x 20	6	2	1
PCN902	10	2.87	12	1.25	27.5 x 20	6	2	1

CONSERVING ENERGY

- Turn off unused equipment.
- Do not open door unnecessarily; use window for observation of food in oven.

COOKING TEMPERATURES AND TIMES

Because of the moving air in the convection oven, the temperatures required to bake various products are lower and the cooking times are shorter than in a conventional deck-type oven with still air. Since recipes and foods are subject to many variations and tastes, the guidelines regarding temperature settings and cooking times contained in this manual are *SUGGESTED ONLY*. You should experiment with your food products to determine the cooking temperatures and times that give you the best results.

GUIDELINES FOR BAKING AND ROASTING

PRODUCT	TEMPERATURE	TIME	NO. RACKS
BREAD PRODUCTS			
Bread (24, 1-lb. loaves)	340F	30 min.	3 (every other rack starting with bottom rack)
Hamburger Rolls	300F	15 min.	5
Corn Bread	335F	25 min.	5
Yeast Rolls	325F	25 min.	5
Baking Soda Biscuits	400F	6 min.	5
PASTRIES			
Frozen Berry Pies (22 oz.)	350F	34 min.	5 (30 pies)
Frozen Fruit Pies (46 oz.)	350F	45-50 min.	5 (20 pies)
Fresh Apple Pie (20 oz.)	350-375F	25-30 min.	5 (30 pies)
Sheet Cake (5 lbs. per pan)	315F	20-22 min.	5
Sugar Cookies	300F	15 min.	5
Cherry Crisp	300F	25 min.	5
Chocolate Cake	335F	20 min.	5
Cinnamon Buns	335F	20 min.	5
Brownies	350F	15 min.	5
Danish	335F	12 min.	5
Angle Cakes	250F	25-30 min.	3
Cream Puffs	350F	20-25 min.	5
Pumpkin Pie	300F	30-35 min.	5
Fruit Cakes	275F	70 min.	3
Apple Turnovers	350F	15 min.	5
MEAT			
Hamburger Patties (5 per lb.) (well done)	400F	10-12 min.	11 (264)
Steamship Round (80 lb. quartered)	275F	2¾ hrs. (well done)	2 (2 pans ea. rack)
Steamship Round (whole 60-80 lbs.)	275F	8 hrs. (med.)	1
Rolled Beef Roast (20 lb. avge.)	300F	4 hrs. (med.)	3 (2 roasts per pan)
Prime Ribs	275F	3 hrs. (med.)	2 (2 roasts per pan)
Baked Stuffed Pork Chops	375F	25-30 min.	5
Boned Veal Roast (15 lbs.)	300F	3 hrs. 10 min.	2
Lamb Chops (small lean)	400F	6 min.	5 (24 per pan)
Shell Steaks (10 oz.)	450F	7-8 min.	5 (16-18 per pan)
Meat Loaf	325F	40-45 min.	5 (2 pans per rack)
FISH			
Fish Stix	335F	16-18 min.	11
Baked Stuffed Shrimp	400F	6-7 min.	5
Baked Stuffed Lobster (1½ lbs.)	400F	10 min.	3
Halibut Steaks (Frozen 5 oz.)	350F	30 min.	5
FOWL			
Chicken Breast — Thigh	350F	33-35 min.	5
Chicken Back — Wing	350F	30-33 min.	5
Chicken (2½ lb. quartered)	350F	30 min.	5 (26 per pan)
Turkey Rolled (18 lb. Rolls)	310F	3¾ hrs.	3 (6 pan - 2 rolls ea. rack)
OTHER			
Macaroni and Cheese	350F	30 min.	5
Beef Pot Pies	400F	30-35 min.	5
Turkey Pot Pies	400F	30-35 min.	5
Stuffed Peppers	350F	15-20 min.	3
Melted Cheese Sandwiches	400F	10 min.	5 (120)
Pizza (7" Frozen)	435F	11 min.	6
Idaho Potatoes (120 count)	440F	50 min.	5

*Where the number racks is 5, insert the first rack on the bottom position and place the others on every other rung.

CLEANING YOUR CONVECTION OVEN

Always allow the oven to cool prior to cleaning. If the oven is hot, make sure the doors are only slightly ajar to minimize the exposure of the operator to the hot air. To speed up the cooling process:

Leave the door ajar.

Press the COOL/TEMP button. The fan will come on at high speed and will turn alternately on and off each time the COOL/TEMP button is pressed.

When the oven has cooled sufficiently, set the ON/OFF switch to OFF and clean the oven.

CLEANING THE INTERIOR OF YOUR OVEN

Ovens With Standard Aluminized Steel Liners

Keep the inside of the oven and racks wiped clean. If food particles or carbon accumulate so doors cannot be tightly closed, heat is wasted and the oven will not operate properly. Poorly closed doors permit a constant escape of steam and vapor around the door. This causes condensation which deteriorates the finish around the oven front and door lining.

When cleaning the interior of your oven, it is important to bear in mind that the aluminum coating, though tightly adherent, is still a coating. To preserve the coating and for ease of maintenance, clean often when the oven is cold with mild detergent (or soap) and water. This will prevent food and dirt from "baking on" and will frequently be all the cleaning that is necessary.

Where soil resists soap and water cleaning, use a wooden tool to loosen spillage from the cold oven. Follow with a non-etching cleaner which is specifically recommended for aluminized steel. Use clear water to rinse; dry with a soft clean cloth.

DO NOT USE STEEL WOOL, WIRE BRUSHES OR CAUSTIC SOLUTIONS SUCH AS LYE, SODA ASH, OR AMMONIA.

Ovens With Stainless Steel Liners

In general, the principles detailed above for aluminized steel apply. Soap or detergent and water will usually handle routine cleaning; dry with a soft clean cloth.

For burned-on foods and grease which resist simple soap and water cleaning, an abrasive cleanser (scouring powder) mixed into a paste may be used. Apply with stainless steel wool or sponge, always rubbing with the "grain".

This treatment is equally effective for "heat tint" (slightly darkened areas caused by oxidation). Again, remember to rub in the direction of the polish lines. Rinse with clear water and dry with a soft cloth.

REMOVING PANELS

WARNING: DISCONNECT ELECTRICAL POWER SUPPLY AND PLACE A TAG AT THE DISCONNECT SWITCH TO INDICATE THAT YOU ARE WORKING ON THE CIRCUIT.

Remove tray racks by pulling straight out.

Remove right and left rack guides by lifting straight up.

Right and left panels may now be removed by moving toward the center and pulling out. To avoid scratching, do not rest panels on bottom panel.

Remove bottom panel by pulling straight out.

Remove blower baffle by lifting straight up and pulling out toward the front. Care should be exercised to clear brackets on the side. Blower wheel can now be cleaned as described in *Cleaning The Blower Wheel*, immediately following.

Top panel and stainless steel interior panels can be cleaned while in place. If removal of top panel is desired, unscrew three screws from front top edge of top and two screws from rear flange of top. Slide out toward front.

Reassemble by reversing the above procedure.

CLEANING THE BLOWER WHEEL

WARNING: DISCONNECT ELECTRICAL POWER SUPPLY AND PLACE A TAG AT THE DISCONNECT SWITCH TO INDICATE THAT YOU ARE WORKING ON THE CIRCUIT.

Remove all racks by pulling forward, lifting up and out.

Remove both right and left rack supports by lifting up.

Remove the blower baffle by lifting up and pulling out. Wash blower thoroughly with hot sudsy water using a sponge or plastic web pad. Rinse with clean water and dry.

Replace the hardware by reversing the disassembly procedure.

CLEANING THE EXTERIOR OF YOUR OVEN

Wash all exterior surfaces at least once daily using a cloth with warm water and a mild soap or detergent. Where surfaces have been waxed, use the cloth lightly — hard rubbing will remove polish. Follow with a clear rinse, then dry. This simple treatment will keep your equipment clean and sparkling, and eliminates the danger of grease accumulation.

Permalucent Finish

If grease has accumulated and attacked the PERMALUCENT finish, use any silicon-based polish following directions on the container. NEVER use a scouring pad on the PERMALUCENT finish.

If the surface is accidentally marred, it can be quickly and easily restored with a "PERMALUCENT Touch-Up Kit", available through your Dealer. Full instructions are in each kit.

Cleaning Stainless Steel Surface

To keep the stainless steel front spotless, clean regularly with a damp cloth and polish with a soft, dry cloth. To remove discolorations which may have formed when regular cleaning was neglected, use any detergent or plain soap and water. For particularly stubborn discolorations, a self-soaping scouring pad may be used.

CAUTION: Always rub with the "Grain" in a horizontal direction.

Rinse, dry and polish with a soft cloth. Avoid using gritty soaps or harsh cleaners.

REPLACING LAMPS

WARNING: DISCONNECT ELECTRICAL POWER SUPPLY AND PLACE A TAG AT THE DISCONNECT SWITCH TO INDICATE THAT YOU ARE WORKING ON THE CIRCUIT.

Remove all racks by pulling forward, lifting up and out.

Remove both the right and left rack supports by lifting up.

Remove ten screws from the light window bezel.

Pull out the bezel and window.

Replace the bulb(s).

Replace the hardware by reversing the disassembly procedure.

NOTE:

OPEN STAND
 CX286 C990, C992, DN97 & P990
 CX337 C991, C993 & DN98

NOMINAL DIMENSIONS IDENTICAL TO CABINET
 BASE AS SHOWN BELOW, EXCEPT LESS DOORS,
 SIDES & BACK.

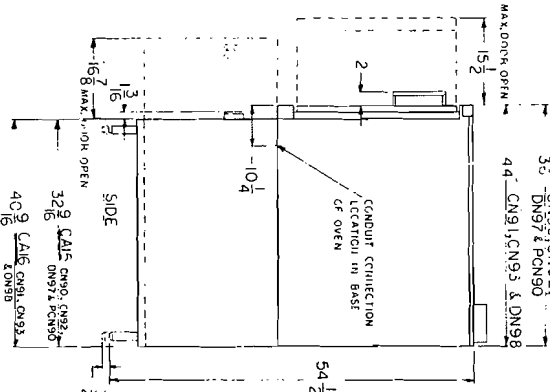
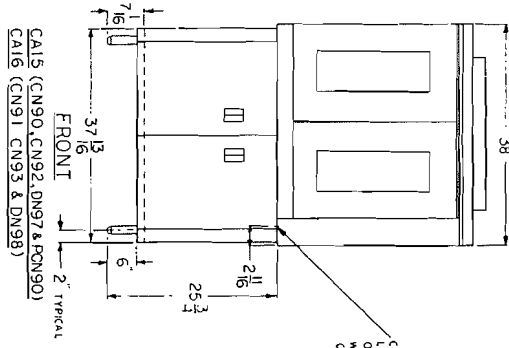

CABINET BASE

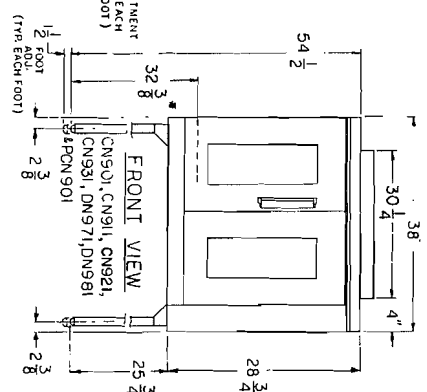

* FOR C990, C991, C992, C993, DN97, DN98, DN99, DN99A, DN99B, DN99C, DN99D, DN99E, DN99F, DN99G, DN99H, DN99I, DN99J, DN99K, DN99L, DN99M, DN99N, DN99O, DN99P, DN99Q, DN99R, DN99S, DN99T, DN99U, DN99V, DN99W, DN99X, DN99Y, DN99Z, P990, P991, P992, P993, P994, P995, P996, P997, P998, P999

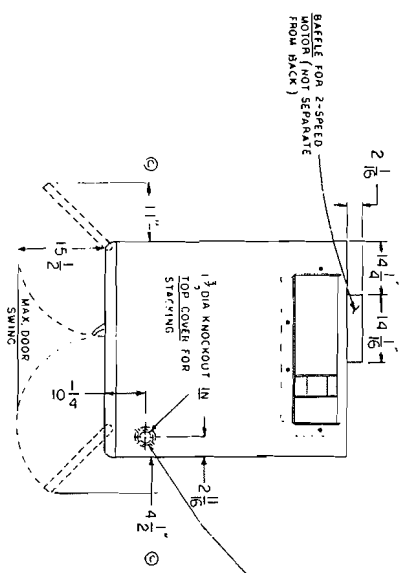

TOP VIEW

C990, C991, C990, C992, C993, C9904, C991, C9912, C993, C9914, C992, C9921, C9922, C9923, C9924, C993, C9931, C9932, C9933, C9934, DN97, DN971, DN972, DN973, DN974, DN98, DN981, DN982, DN983, DN984, C990, P9901, P9902, P9903 & P9904

