

168 to 175 Laying procedures

- 171 Tiles
- 172 Sheet
- 173 Saga
- 174 Conductive, dissipative and antistatic floorcoverings
- 174 Conductive flooring with conductive adhesive and conductive primer
- 175 Laying procedure for residential sheet products

176 Cold and hot welding

177 Adhesives

178 to 181 Maintenance

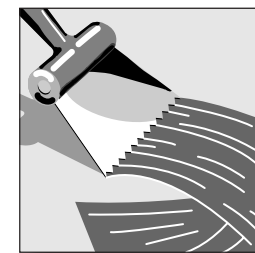
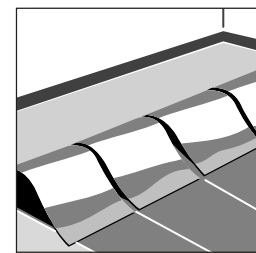
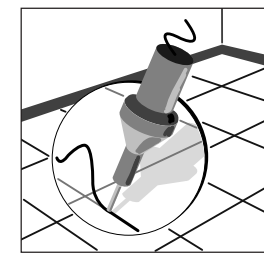
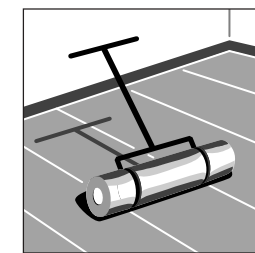
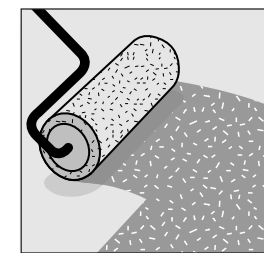
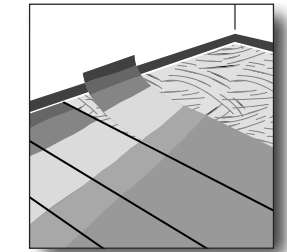
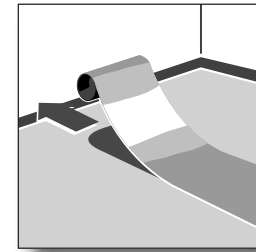
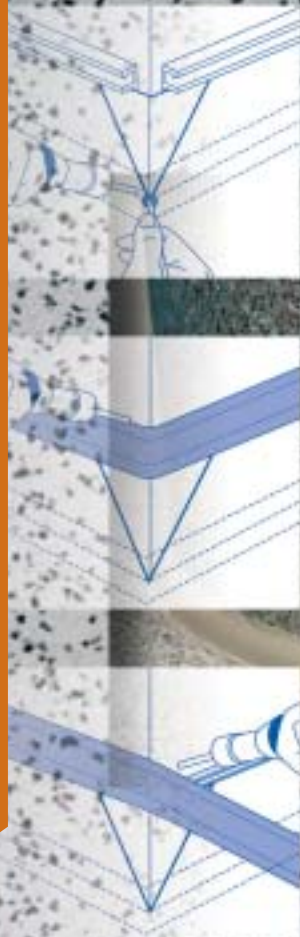

PREPARING THE SUBFLOOR

The flooring contractor has responsibility for laying the floorcovering only when he is satisfied that the subfloor is in a suitable condition to receive the flooring.

Local regulations regarding subfloors and the installation of floorcoverings must be complied with.

**GENERAL INFORMATION
(NEW SUBFLOORS OR RENOVATION)**

The subfloor must be absolutely hard, level, dry, smooth and structurally sound.

The subfloor must be free of cracks and other irregularities and must not be contaminated with paint, plaster, oil, grease or any other substance which could affect adhesion.

Cracks must be filled with an appropriate material.

The following information provides you with basic installation procedures. For technical products or more detailed instructions please refer to our technical guide.

Laying procedure for tiles

Hardness

Use cement based products for subfloor preparation. They must be neither crumbly nor flaky.

Flatness

Maximum deflexion, for a 2 m ruler 7 mm, for a 0.20 m ruler 2 mm.

Surface state: fine and regular.

Dryness

Moisture content in subfloors should be measured using appropriate devices and should be in accordance with relevant standards in each country. The relative humidity must not be higher than 75 % R.H.

Adapt the drying time according to how cold or damp the conditions are.

Smoothness

A smoothing compound must be applied to the entire surface according to the standards mentioned above. Smoothing compounds are not designed to overcome levelling deficiencies. The smoothing compound must be allowed to dry in accordance with manufacturer's instructions.

Rub down using a carborundum stone in order to obtain a perfectly smooth surface.

Sweep or vacuum up any dust. Spread the adhesive.

Expansion joints or movement joints

Floorcovering should be laid up to the joint and the joint should be covered with an appropriate plastic or metal sliding joint cover.

Subfloors direct to ground

A damp-proof membrane must be laid under the concrete to act as a waterproof barrier against underlying hydrostatic pressure and moisture.

Underfloor heating

The subfloor must be allowed to dry in accordance with local standards.

The heating system should have been switched on at least 4 weeks before laying the floorcovering, then switched off 24 hours before any subfloor preparation, and remains switched off during installation of the floorcovering.

The heating should then be switched on 48 hours after installation of the flooring and the temperature progressively increased to normal working temperatures over 5-7 days.

Glueline temperature < 28 °C (contact technical department for further information.)

Old carpeting

Remove, clean the subfloor and apply a smoothing compound.

Wooden floorboards

Check the condition of the floorboards, secure any loose boards.

Any knotholes to be filled as necessary.

Cover with hardboard, chipboard or plywood, minimum thickness 8 mm.

These sheets should be nailed or stapled every 10-15 cms.

Check that the floorboards are dry and ventilated on the underside.

All non ventilated woodenfloors must be removed.

Ceramic tiles

Any loose tiles must be stuck down and any traces of paint, plaster, grease, etc, must be removed. The cleaned tiles must be primed with an appropriate primer prior to applying a smoothing compound fully in accordance with manufacturers instructions.

Leave to dry then rub down to a smooth finish.

Sweep thoroughly. Apply the adhesive in accordance with manufacturers instructions.

Old vinyl flooring

Old vinyl, linoleum and rubber floorcoverings should always be removed and the subfloor be examined and prepared as necessary before installing new floorcoverings.

Unpack the tiles 24 hours before laying and make sure they are stacked horizontally.

⚠ **Minimum ambient temperature must be 15 °C.**

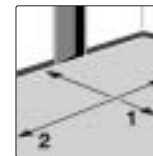

1. Trace a line perpendicular to the main entrance. Trace a perpendicular line to this axis ensuring equal cuts for tiles on both sides.

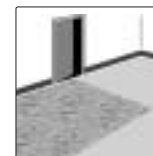

2. Apply adhesive to a few square metres of subfloor in one quarter.

⚠ **Insufficient open time of the adhesive will cause bubbles. If open time is too long the adhesive transfer will be poor.**

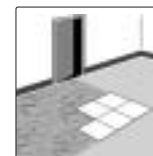

3. Press each tile into position ensuring joints are butted tight.

⚠ **Beware installation directions according to pattern.**

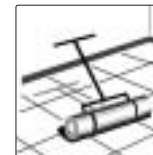

4. Smooth down manually then roll with a 50 kg flooring roller.

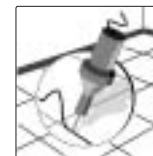

5. If necessary heat weld seams 24 hours after installation.

⚠ **Do not traffic the floorcovering for 48 hours after installation.**

Sheet laying procedure

The sheets must be unrolled and left in the room to be covered, with the adhesive, for at least 24 hours prior to laying.

⚠ **Minimum temperature must be 15 °C.**

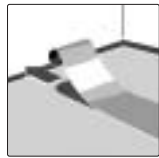

1. Lay first length along guide line, ensuring sheets are laid lengthways in the same direction as the light falls.

⚠ **Beware installation directions according to pattern.**

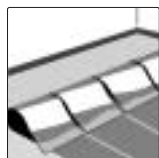

2. Fold back sheets half way.



3. Use a finely serrated trowel to apply the single stick acrylic emulsion adhesive. The adhesive manufacturer's instructions must be followed.

⚠ **Insufficient open time of the adhesive will cause bubbles. If the open time is too long the adhesive transfer will be poor.**

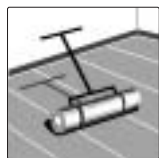

4. Smooth down manually then roll with a 50 kg flooring roller.

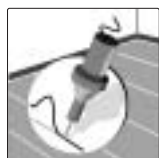

5. If necessary groove and heat weld the joints after 24 hours after installation.

⚠ **Do not traffic the floorcovering for 48 hours after installation.**

Other cases:

Reverse lay the following products: Nera Contract, Taralay Comfort. Please note the reverse lay symbols on the packaging.

Most sheet products are laid by overlapping the edges and cutting through.

Tarasafe Standard, Tarasafe Iona, Tarasafe Comfort, Tarasafe Plus, Tarasafe Ultra, Tarasafe Style, Tarasafe Super however should be laid with a 1 mm gap to allow for the grooving machine. Grooving should be done manually.

Laying procedure for Saga

Overall adhesion with tackifier emulsion adhesive

A gripping primer compatible with the tackifier emulsion adhesive and the subfloor must be applied before gluing.

1 - Positioning of the floor covering

The tiles should be removed from their box at least 24 hours before laying and placed in the room in which they are to be used

2 - Tackifier emulsion adhesive

The tackifier emulsion is applied in a single coat:

- using a finely notched trowel, quantity 100 to 150 g/m², type A1,
- using a foam roller, quantity 100 to 150 g/m².

3 - Laying of tiles. Alignment.

A - When laying the tiles, the following points must be respected:

- use whole tiles or large cut tiles (more than 50% of the original tile size), in heavy traffic zones (door thresholds, corners in corridors, waiting areas),
- align a row of tiles along the main access paths,
- align one of the start lines with the longest wall-to-wall direction in the room.

B - Alignment.

Trace a guide line along which the tiles are to be laid (see fig 1).

4 - Preparation of subfloor and laying of tiles.

⚠ **Beware installation directions according to the pattern.**

- Spread the tackifier emulsion adhesive over half the room.
- Lay the first row of tiles along the axis perpendicular to the door.
- Block this row in place using the wall as a support (see fig 2).
- Lay the following rows of tiles and block them against the first row.

5 - Smoothing.

This operation must be carried out in two stages .

- Smooth down manually.
- Roll with a 50 kg flooring roller over the entire surface.

Positioning of furniture.

When positioning furniture, pay attention not to drag heavy objects over the floorcovering

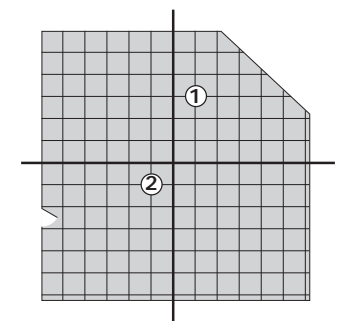

①

Tracing the guide lines:

- axis perpendicular to main entrance,
- the perpendicularity of this axis is balanced by the tile cuts.

②

- Starting in the middle of the room, lay the tiles of the middle row. Block this row in place using the wall perpendicular to this row as a support.
- Lay the following rows of tiles and block them against the first row.

Antistatic products

Normal laying using high performance acrylic adhesive which has low water content. The flooring has antistatic properties of its own. These properties do not depend on the laying method used. Copper strips are not necessary.

Dissipative products and conductive products

There are two laying systems:

- with conductive adhesive and conductive primer,
- on a copper strip grid with a high-performance acrylic adhesive which has low water content.

Copper strips: code 0584

Width: 1 cm

Average length: 250 lm

Thickness: 6/100 mm

Weight: about 3.6 kg

LAYING PROCEDURE FOR CONDUCTIVE FLOORING WITH CONDUCTIVE ADHESIVE AND CONDUCTIVE PRIMER

The sheets must be unrolled and left in the room to be covered, with the adhesive, for at least 24 hours prior to laying.

⚠ **Minimum ambient temperature must be 15 °C.**



1. Apply a conductive primer.
The coverage should be 100-150 g/m².
Leave to dry for at least 12 hours.



2.1 Sheets
Lay first length along guide line, ensuring sheets are laid lengthways in the same direction as the light falls.

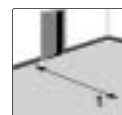

2.2 Tiles
Trace a line perpendicular to the main entrance.

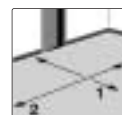

Trace a perpendicular line to this axis ensuring equal cuts for tiles on both sides.

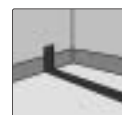
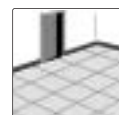

3. Use 2 lm of copper strips for every 30 m² for earthing.
Connect the copper strip to the earth (1 earth for every 30 m²).
For rooms over 30 m², lay copper strips at the periphery of the room and on the diagonal.



4. Adhering with acrylic single stick conductive adhesive (type Cégé 100 Conductrice - Akzo-Nobel) and a sharp-serrated notch, or similar approved adhesive. The coverage should be approximately 200-300 g/m².
In order to achieve a regular and appropriate coverage change the spatula regularly.

⚠ **Carefully follow the manufacturer's instructions when applying primer and adhesive. Ensure that the supplier can provide a 10 year guarantee for the conductivity of the adhesive.**



5.1 Lay the sheets.



5.2 Lay the tiles.

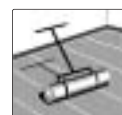

6. Smooth down manually then roll with a 50 kg flooring roller.



7. Groove and heat weld the joints 24 hours after installation (compulsory).
Dried adhesive on surface of flooring may be removed with alcohol or turpantin.

⚠ **Do not traffic the floorcovering for 48 hours after installation.**

LAYING PROCEDURE FOR RESIDENTIAL SHEET PRODUCTS

Check that the subfloor on which you intend to lay the floorcovering is smooth, free from grit, grease and wood treatments. Most of these floorcoverings should not be laid over damp areas although Texline and Griptex have higher tolerances for damp. Please refer to the Technical Department for further advice.

The floorcovering should be placed in the room where it is due to be laid for at least 2 hours prior to laying. The temperature should no less than 18oC.

If you plan to lay two or more widths please ensure sufficient material is purchased to allow for pattern match.

Sheet lengths should be reversed laid.

Most installations can be safely loose laid whilst ensuring that exposed edges that may be kicked up (such as doors and joints) are securely adhered to the floor using an 8 to 10cm width application of Gerflor E120 adhesive. Joints should be treated with Gerflor Cold Weld Liquid SG916 to ensure a strong bond. We recommend threshold strip to be fitted to doorways.

For permanent installations or where heavy domestic furniture such as washing machines are likely to be moved around, the floor covering can be fully adhered to the subfloor.

Cold welding

Cold welding with SG 916 or TARAJOINT is necessary to create a continuous hygienic surface.
If this treatment can withstand traction of 8 daN/cm, the P3 requirement has been met.

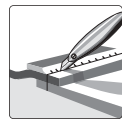

1. Overlap the edges by 3 or 4 cm and cut through both thicknesses with a stanley knife using a ruler as a guide-line. It is beneficial to place a flat straight edge beneath the joint to be cut. This will avoid damaging the subfloor and ensure a tight butt joint is achieved. Butt the sheet edges together to form a compression joint.

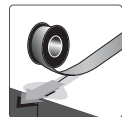

2. Cover the joint with paper adhesive tape.



3. Cut through the tape into joint.

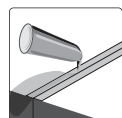

4. Fit the necessary nozzle onto the bottle, depth welding: nozzle with guide, surface welding: feed nozzle. Insert nozzle into joint and squeeze bottle until there is an excess of liquid on the surface of the tape. Wait for 60 seconds.

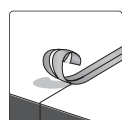

5. Remove adhesive tape.

Adhesives

PRINCIPLES FOR SUCCESSFUL ADHESION

Instructions for use are given by the adhesive manufacturer. These are given for normal hygrometric conditions and subfloor porosity. They may need to be modified according to on-site conditions.

MAIN TYPES OF ADHESIVE

Water-based or emulsion :

suitable for most types of flooring. Their bonding capability is determined according to their rate of evaporation. They are normally applied with a finely notched trowel or roller.

Contact adhesive :

These are resins in solution and flammable. They are usually double stick and applied using a stiff brush or trowel.

Polyurethane contact adhesive is recommended for difficult areas eg. Skirting pannels to PVC

Two part adhesives.

This type of adhesive (epoxy + polyurethane) is used for flooring subjected to heavy traffic, dampness or exposure to the elements. Single application.

RECOMMENDED ADHESIVES PER PRODUCT TYPE

For more information please contact our technical department.

Hot welding

Allow 24 hours after laying. Welding can then be done either manually or mechanically using a welding machine and weld rod.



1. Grooving can be done manually or mechanically using an electric grooving machine.
• Foam backed vinyl: only groove through the depth of the wearlayer.
• Homogeneous material: the depth of the groove should be equal to the total thickness of the material minus 0.3 mm.

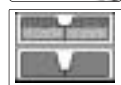

⚠ Tarasafe, Tarasafe Comfort, Tarasafe Ultra, Tarasafe Style, Tarasafe Super : it is recommended to butt joint leaving a 1 mm gap.



2. Mechanical or manual welding.



3. Trimming the joint:
• first trim using a crescent bladed knife with a cable slide,
• when the joint has fully cooled, trim for a second time with a crescent bladed knife to ensure that the weld rod is flush with the floorcovering.
For E3 classification it is compulsory to install set-in covered skirting with a welded joint.



Gerflor floorings, in common with all heavy duty floorings, require correct and regular maintenance. Whatever the manufacturing finish, satisfactory results can only be obtained by following certain basic maintenance rules.

Rubber leaves indelible stains on vinyl floorings :

- do not use mats with rubber backing
- replace tubular furniture feet with those made of PVC or polyamide (do not use rubber furniture feet and wheels)

Never use solvent-based wax, seals, polishes or varnish, particularly those containing acetone and other PVC solvents. Place a barrier mat (which does not have a rubber backing) in doorways and entrances. Delay maintenance until 72 hours installation for rolls and an entire week after installation for tiles.

Six types of maintenance are recommended according to the floorcovering installed :

- Very low maintenance = floorings with PROTECSOL® treatment
- Very low maintenance for high quality homogeneous flooring PUR PROTECT®

- Low maintenance = floorings with polyurethane (PUR) treatment
- Normal maintenance for homogeneous floorings PU treated.
- Normal maintenance = non treated floorings
- Specific maintenance = antistatic and conductive floorings

VERY LOW MAINTENANCE PRODUCTS

- With PROTECSOL® treatment: Taralay Impression, Brazilia, Forum, Jamaica, Metallica, Saga.
- With SPARCLEAN® treatment: Tarasafe Style, Ultra.
- With PUR protect treatment: Mipolam Elegance 290, Mipolam Esprit 500.

It is not necessary to seal the floor during its lifetime, the maintenance cost will be greatly reduced during the life of the floor.

INITIAL CLEANING

Remove loose debris after the installation of floor. Wash floor with a low speed cleaning machine (150-200 rpm) fitted with a red pad. Use neutral detergent. Ensure that all detergent residues are rinsed and removed from the floor.

PROTECTION

This step also know as "metallisation", "self-shine", or "polishing", is not necessary.

DAILY MAINTENANCE

Remove dirt with a damp mop and neutral detergent. Dry sweeping is also possible. Mechanical maintenance provides better aesthetic results.

PERIODIC MAINTENANCE

Clean with a high speed (450 rpm) machine fitted with a red pad or nylon brush or scrubbing machine + neutral detergent.



LOW MAINTENANCE PRODUCTS

With PUR treatment:

- Nera Contract, Mipolam Activa 250, Mipolam Troplan 100, Classic Imperial, Ambiance, GTI, GTI AS Decor, Attraction™, Creation*, Artline*.

* Except Slate and Peeble

PUR treatment is a protective polyurethane surface treatment applied to the product during the manufacturing process.

Results : it is not necessary to seal the floor after installation. Protection is required when aesthetic and hygienic properties are judged inappropriate by maintenance staff. In the meantime, maintenance costs are reduced.

INITIAL CLEANING

Remove loose debris after the installation of the floor. Wash floor with a low speed cleaning machine (150-200 rpm) fitted with a red pad. Use neutral detergent. Ensure that all detergent residues are rinsed and removed from the floor.

PROTECTION

This step also know as "Metallisation", "selfshine", or "polishing" is only necessary when aesthetic

and hygienic properties are judged inappropriate by maintenance staff.

DAILY MAINTENANCE

Remove dirt with a damp mop and neutral detergent or floor maintainer. Dry sweeping is also possible.

PERIODIC MAINTENANCE

Clean with a high speed (450 rpm) machine fitted with a red pad, or nylon brush, or a scrubbing machine + neutral detergent, or floor maintainer.

NORMAL MAINTENANCE PRODUCTS

- With PU factory seal : Univers
- Non treated floorings: Architecton, Tarasafe ranges.

INITIAL CLEANING

Remove loose debris after the installation of floor. Wash and clean off with a machine fitted with blue or green pad + stripping agent at 150-200 rpm. The brown pad is suitable for removal of heavy dirt and/or grease. Ensure that all detergent residues are rinsed and removed from the floor.

PROTECTION

This step is also know as "metallisation", "self-shine", or "polishing". It is usual to apply 3 coats of polish to new floors, as this will impair the slip resistance, allowing one coat to dry before applying the next coat.

Do not go through this treatment with the following products:

- Tarasafe, Tarasafe Iona, Tarasafe Comfort, Tarasafe Ultra, Tarasafe Style, Tarasafe Super, to keep their slip resistance properties.

DAILY MAINTENANCE

Remove dirt with a damp mop and neutral detergent or disinfectant. Dry sweeping may be sufficient.

PERIODIC MAINTENANCE

Clean with a high speed (450 rpm) machine fitted with a blue or red pad using a spray detergent or floor maintainer.

For Tarasafe ranges, clean with a machine fitted with a blue or green pad (450 rpm) or a scrubbing machine + neutral detergent.

Every year protection should be removed and reapplied.





SPECIFIC MAINTENANCE PRODUCTS

Static control floorings : Mipolam Robust EL7, Mipolam Technic EL5, Mipolam Forum EL5.

INITIAL CLEANING

Remove loose debris after the installation of floor.
Wash and clean off a machine fitted with blue pad + stripping agent (such as REMAT manufactured by WETROK) at 150-200 rpm. Ensure that all detergent residues are rinsed and removed from the floor. The green pad is suitable for removal of heavy dirt and/or grease.

PROTECTION

This step is also known as "metalisation", "self-shine", or "polishing". Do not protect the floors in surgery rooms : only apply one coat of MEPOL HMA manufactured by WETROK or equivalent complying with electrical properties.



DAILY MAINTENANCE

Damp mop and neutral detergent and disinfectant to remove dirt.

PERIODIC MAINTENANCE

Clean with a high speed (450 rpm) machine fitted with a red pad or nylon brush + neutral detergent.

RESIDENTIAL FLOORING

Caring for Gerflor cushioned vinyl It is important to clean the floor regularly to avoid any build up of dirt and grit that can damage the surface.

Sweep the floor thoroughly. Add a small amount of neutral liquid cleaner to warm water and clean floor thoroughly. After cleaning the floor must be rinsed with clean water to remove all traces of the cleaning agent. NB: Manufacturers' recommendations for dilution rates, usage and rinsing should be strictly adhered to.

STAIN REMOVAL TABLE

Blood – Urine – Faeces : Use diluted bleach and thoroughly rinse with water to remove all residues.
Vinegar – Tomato – Mustard : Add a few drops of ammonia to water, this may remove the stain.

Rust : Use either proprietary anti-rust treatment or oxalic acid (rinse thoroughly).

Heavy grease – Paint – Rubber scuffs – Hair colourings – Food fats – Ball point or felt-tip pens : Petrol. White Spirit. Scrub using an undiluted detergent, rinse thoroughly and remove all residues.

Cigarette burns : For calendered products : rub gently with a very fine grade sandpaper, or fine wirewool. Apply a self-shine emulsion over the entire surface.

TYPE OF PROCESS:	COMPANY:	W & M FRANCE PROFESSIONAL SAS	ECOLAB	JOHNSON DIVERSEY	KIEHL FRANCE	
FLOORS WITH PROTECTOL® : NEVER POLYMER EMULSION OR DISPERSION	TYPE OF PRODUCT:	ADRESS: Parc des Barbannières F-92230-GENNEVILLIERS T: +33 1 41 47 35 71 F: +33 1 41 47 35 95 www.wmprof.com	8, rue Rouget de Lisle 92442-ISSY-LES-MOULINEAUX T: +33 1 40 93 93 86 F: +33 1 40 93 93 97 www.heinkel-ecolab.com	9, 11 av. du Val de Fontenay 94133-FONTENAY-sous-BOIS T: +33 1 45 14 76 76 F: +33 1 45 14 76 11 www.johnsondiversey.com	1, rue de l'Industrie-BP 54 F-67172 BRUMATH CEDEX T: +33 3 88 59 52 25 F: +33 3 88 59 52 20 info@kiehl.fr	
	OTHER FLOORS TO PROTECT	NATURAL CLEANING AGENT	DYNATECH CLEAN FORCE DYNATECH CLEAN FRESH	GLOSS EXPRESS BRIAL CALYPSO	JONTEC ASSET JONTEC 300	VERIPROP
		ALKALINE CLEANING AGENT	DYNATECH ALKA	NEOMAT A	JONTEC COMBINET JONTEC STRIPE JONTEC DEGRAISSANT	DOPOMA INTENSO
		CLEANING AGENT (REMOVING RUBBER MARKS)	DYNATECH STRIPP	BENDUROL FAST NEOMAT RENOVANT	JD ATTACK PLUS	RAPID LI-EX COPEX
		DESINFECTANT DETERGENT	DYNATECH CLEAN BACTO	DIESIN PLUS FIORD PLUS	SPRINT DEGRABERM SPRINT DS 5001	PROCUR diluted
		CLEANING AGENT (HIGH TRAFFIC)	DYNATECH PHENIX	INDUR TOP HELOTSTAR	JONTEC TENSO	
		SPRAY DETERGENT	DYNATECH BACTISPRAY	INDUR BRILLANT PLUS	JONTEC ASSET	ARISTON
		MOP WAX	DYNATECH DUO	BENDUROL FAST BENDUROL FORTE	JONTEC EXTRA JONTEC COMBINET	COPEX POLY-EX LI-EX
		STRIPPER	DYNATECH SUPER STRIPP DYNATECH STRIPP	NOVASEC	JONTEC N° 1F JONTEC FUTUR	COPEX POLY-EX LI-EX
		STRIPPER (DRY)	DYNATECH SECCO	PRESEAL XL SPIRIT SEALER	JONTEC STRIPO	COPEX POLY-EX LI-EX
PRIMER		DYNATECH PREBASE	ISLSTAR TUKLAR SUPER METALLIC	JONTEC TECHNIQUE	THERMODUR	
PROTECTIVE LAYER	DYNATECH PROTECTION DYNATECH FORCE OPTIMA DYNATECH TRIO	LONGLIFE	JONTEC ETERNUM JONTEC LUNA	TASKI VISION MATT TASKI VISION SILK TASKI VISION STAR		
CLEANING OF POLYMER EMULSION	DYNATECH FORCE	RESISTO DES	JONTEC ETERNUM JONTEC RESTOL	TASKI VISION MATT TASKI VISION STAR		
RENEWAL OF POLYMER EMULSION	SPRAY CLEANER	SUPER CLEAN	JONTEC ASSET	PROCUR diluted		
	SPRAY EMULSION	DYNATECH MULTISPRAY	JONTEC RESTORE	TASKI P14 (<300H/mm) TASKI OMNISPRAY		

