

Installation & Operating Manual

The TL300 Top Loading Wood Stove

HARMAN™

BUILT TO A STANDARD, NOT A PRICE

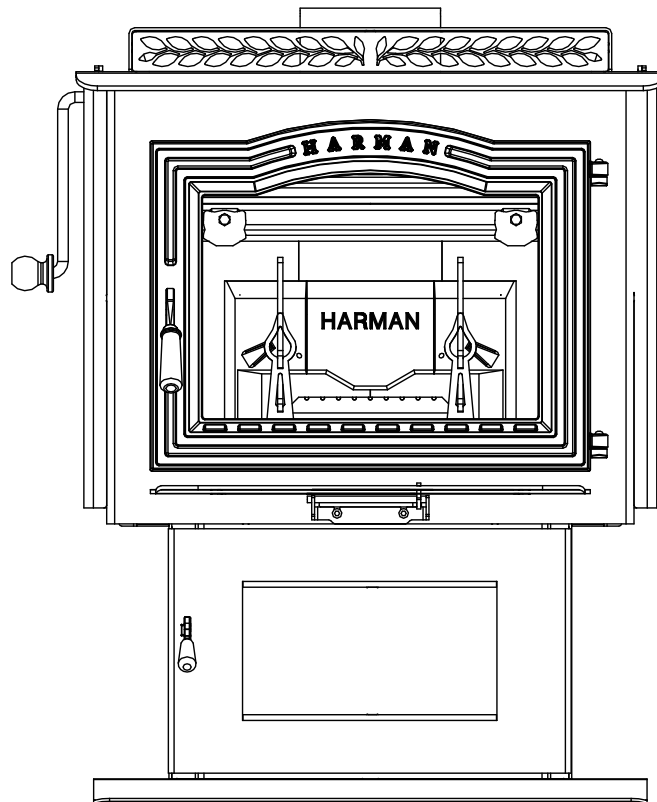

We suggest that our hearth products be installed and serviced by professionals who are certified in the U.S. by the National Fireplace Institute (NFI) as NFI Specialists.

Tested & Listed By  Portland Oregon, USA
OMNI-Test Laboratories, Inc.
EPA Certified by
OMNI-Test Laboratories **R7**

SAFETY NOTICE

PLEASE READ THIS ENTIRE MANUAL BEFORE YOU INSTALL AND USE YOUR NEW ROOM HEATER. FAILURE TO FOLLOW INSTRUCTIONS MAY RESULT IN PROPERTY DAMAGE, BODILY INJURY, OR EVEN DEATH.

FOR USE IN THE U.S. AND CANADA. SUITABLE FOR INSTALLATION IN A MOBILE HOME(US ONLY).

IF THIS WOOD-BURNING STOVE IS NOT PROPERLY INSTALLED, A HOUSE FIRE MAY RESULT. FOR YOUR SAFETY, FOLLOW INSTALLATION DIRECTIONS.

CONTACT LOCAL BUILDING OR FIRE OFFICIALS ABOUT RESTRICTIONS AND INSTALLATION INSPECTION REQUIREMENTS IN YOUR AREA.

CONTACT YOUR LOCAL AUTHORITY (SUCH AS MUNICIPAL BUILDING DEPARTMENT, FIRE DEPARTMENT, FIRE PREVENTION BUREAU, ETC.) TO DETERMINE THE NEED FOR A PERMIT.

CETTE GUIDE D'UTILISATION EST DISPONIBLE EN FRANCAIS. CHEZ VOTRE CONCESSIONNAIRE DE HARMAN HOME HEATING.

SAVE THESE INSTRUCTIONS.

3-90-06901

Index

Introduction	4
Specifications	5
Installation	8
Venting	10
Operation/Building a Fire	16
Maintenance	19
Options	21
Service Parts	22
Warranty	26

Please read this entire manual before you install and use your new heating appliance. Failure to follow instructions may result in property damage, bodily injury, or even death.

Hearth & Home Technologies, Inc.
352 Mountain House Road
Halifax, PA 17032 ~ U.S.A.

Introduction

Thank you for purchasing the Harman TL300 Wood Stove. We are confident that you will enjoy the warmth and convenience of your Harman Stove for decades to come.

With the TL300 you will notice even heat throughout your home and long burn times. This is possible because of Harman's special FireDome Non-Catalytic Combustion System, designed into the TL300 to promote clean burning and even heat output. This equates to unvarying heat over a longer period of time without the temperature peaks and valleys of other wood stoves. The FireDome continues Harman's reputation of high efficiency while saving you the expense associated with catalytic stoves. The top load door makes adding wood easier and allows more wood to fit into the large firebox. You can view your beautiful fire through the extra large glass door. The glass stays cleaner because of the special IR coated glass and the exclusive Harman Air Wash System.

The Harman TL300 has an ash pan with its own ash door which allows removal of ashes while the stove is in operation. This means you can keep a fire all winter if you desire.

The Harman TL300 offers a cooking grill that can be placed in the top of the stove while in operation. This allows you to grill your favorite meats all year long even when the weather is not suitable for outside grilling. If you haven't already purchased the cooking grill, you can do so from your Authorized Harman Dealer.

Due to the fact that the TL300 is hot while in operation, gloves should be worn while tending to the fire.

For your reference, please copy your serial number from the label on your stove to the box below.

SERIAL NUMBER

Appliance Certification.

Model: TL300

Test Lab: Omni-Test Laboratories

Report #: 135-S-18-6

Type: Solid Fuel Fireplace Stove or Room Heater

Standard(s): UL 1482, UL 737, ULC-S627

Note: This appliance is also approved for installation into a shop.

LISTED SOLID FUEL FIREPLACE STOVE OR ROOM HEATER
APPAREIL DE CHAUFFAGE OU POELE A COMBUSTIBLE SOLIDE
MODEL/MODELE: TL300

Report#/Rapport #: 135-S-18-6
 Tested to/Tests a: UL 1482, UL 737
 Meets requirements of ULC S627-00/Selon les exigences de ULC S627-00
 Certified for USA and Canada/Certifié pour les États-Unis et le Canada
 Room Heater, Solid Fuel Type, Also For Use In Mobile Homes In US only

PREVENT HOUSE FIRES: Install and use only in accordance with manufacturer's installation and operation instructions and local codes. In absence of any local codes, installation must meet minimum requirements of NFPA 211 in USA. Refer to manufacturer's instructions and local codes for precautions required for passing chimney through a combustible wall or ceiling.

FOR USE WITH SOLID WOOD FUEL ONLY.
 Do NOT connect this stove to a chimney serving another appliance.
 Flue connector pipe must be 6" diameter, minimum 24 MSG black or 26 MSG blue steel.
 Chimney must be factory built UL 103HT or masonry.

NOTE: Replace glass only with 5mm ceramic glass available from your dealer.
 Inspect and clean chimney frequently. Under certain conditions of use, creosote buildup may occur rapidly.

DO NOT OVERFIRE - IF HEATER OR CHIMNEY CONNECTOR GLOWS, IT IS BEING OVERFIRE.

Prevention des incendies:
 Respectez scrupuleusement les instructions du constructeur pour l'installation et l'utilisation.
 Respectez les règles et normes applicables dans votre région. Dans tous les cas, l'installation devra au minimum satisfaire aux exigences de NFPA 211 AUX États-Unis.
 Reportez vous aux instructions du fabricant et aux règles locales pour les précautions nécessaires lors du passage des tuyaux de fumée à travers un mur ou un plafond combustible. Contrôlez et nettoyez fréquemment la cheminée et les tuyaux de fumée selon les instructions du fabricant.

UTILISÉZ QUE DU BOIS EN BûCHES:
 Ne pas raccorder ce poêle à un conduit de fumée utilisé pour un autre appareil.
 Le tuyau de fumée doit avoir 6" de diamètre minimum, et être en acier de qualité 24 MSG noir ou 26 MSG bleu.
 Le conduit de fumée peut être maçonnerie ou de fabrication industrielle type ULC S629.
 Nota: Ne remplacer la vitre qu'avec une vitre céramique de 45 mm disponible chez votre fournisseur.
 Contrôlez et nettoyez fréquemment la cheminée et les tuyaux de fumée. Dans certaines conditions d'utilisation, des accumulations de crasse peuvent se produire rapidement.

NE PAS SUR CHAUFFER - SI LE POELE OU LE TUYAU ROUGISSENT, VOUS SURCHAUFFEZ.

Manufactured by / Fabriqué par:
HARMAN
 HOME HEATERS
 352 Mountain House Road
 Halifax, PA 17032 (E.-U.)

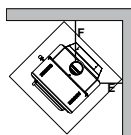

CLEARANCE TO COMBUSTIBLE SURFACES

A - Unit to Sidewall	20"
B - Unit to Backwall	18"
C - Chimney Connector to Sidewall	31"
D - Chimney Connector to Backwall	24"
E - Unit to Adjacent Wall	18"
F - Chimney Connector to Adjacent Wall	27"

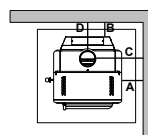

DISTANCES MINIMALES DE SECURITE

A - Entre le mur latéral et l'appareil	500 mm
B - Entre le mur arrière et l'appareil	450 mm
C - Entre le tuyau et le mur latéral	775mm
D - Entre le tuyau et le mur arrière	600 mm
E - Entre le mur adjoint et l'appareil	450 mm
F - Entre le tuyau et le mur adjoint	675 mm

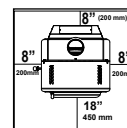

Floor protection must be a non-combustible material. Must also be placed under any horizontal sections of flue connector, extending 2" (51mm) beyond the measurement of the pipe.
 Pour protéger le plancher, il faut sous le poêle un matériau. Qui doit aussi être placé sous les parties horizontales du tuyau de raccord à la cheminée et s'étendre à 51 mm (2 po) au-delà de la mesure du tuyau.

REFER TO MANUFACTURER'S INSTRUCTIONS FOR CLEARANCES WITH ADDITIONAL VENT CONFIGURATIONS.
 Veuillez vous référer au manuel d'instruction du fabricant pour informations additionnels pour la configuration de la ventilation.

ATTENTION: CHAUD LORS DU FONCTIONNEMENT. NE TOUCHEZ PAS L'APPAREIL. GARDEZ LES ENFANTS ET LES VÊTEMENTS ÉLOIGNÉS. TOUT CONTACT PEUT ENTRAÎNER DES BRÛLURES DE LA PEAU. RÉFÉREZ-VOUS À LA PLAQUE SIGNALÉTIQUE ET AU MODE D'EMPLOI. GARDEZ LE MOBILIER ET LES AUTRES MATÉRIEAUX COMBUSTIBLES BIEN À L'ÉCART DE L'APPAREIL.



CAUTION: HOT WHILE IN OPERATION. DO NOT TOUCH. KEEP CHILDREN AND CLOTHING AWAY. CONTACT MAY CAUSE SKIN BURNS. SEE NAMEPLATE AND INSTRUCTIONS. KEEP FURNISHINGS AND OTHER COMBUSTIBLE MATERIALS A CONSIDERABLE DISTANCE AWAY FROM THIS APPLIANCE.

Made in U.S.A. of US and imported parts. / Fabriqué aux États-Unis-d'Amérique par des pièces d'origine américaine et pièces importées.

CONTACT LOCAL BUILDING OR FIRE OFFICIALS ABOUT RESTRICTIONS AND INSTALLATION INSPECTION IN YOUR AREA.
 CONSULTEZ LES ADMINISTRATIONS ET ORGANISMES COMPÉTENTS POUR LA CONSTRUCTION ET LA PREVENTION DES INCENDIES AFIN DE RESPECTER LES REGLES DE SECURITE EN VIGILANCE.

U.S. ENVIRONMENTAL PROTECTION AGENCY
 Certified to comply with July 1990 particulate emission standards.
 Date of Manufacture/Date de fabrication:

2011 2012 2013 JAN FEB MAR APR MAY JUN JUL AUG SEP OCT NOV DEC

Specifications

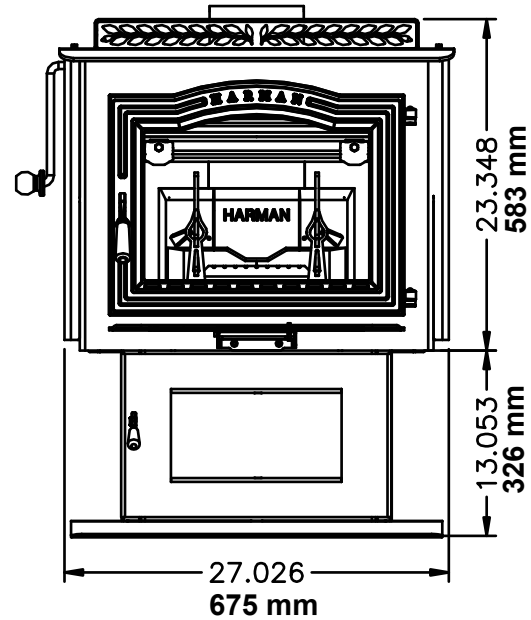
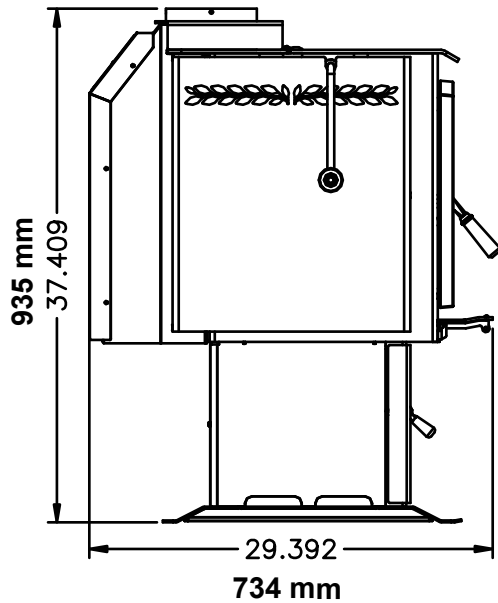

Weight	525 lbs
Flue Size	6 Inch
Log Length Recommended	18 in. / 20 in. Max
Heating Capacity	1,500 - 3,000 sq. ft.
Average Emissions	1.1 Grams Per Hr.
Emissions on Low	0.8 Grams Per Hr.
Outside Air Size	3 or 4 Inch

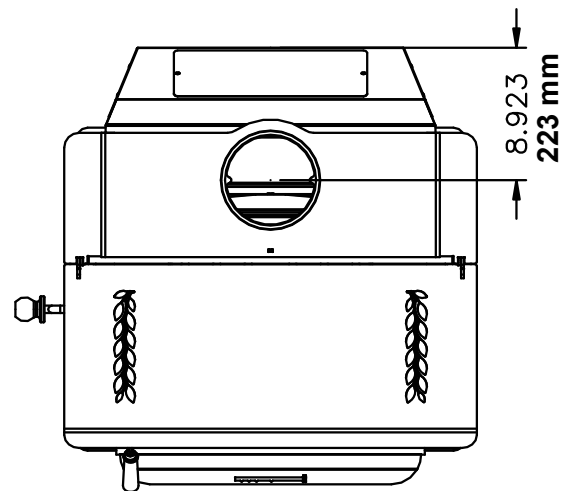

SAFETY NOTICE: IF THIS STOVE IS NOT PROPERLY INSTALLED, A HOUSE FIRE MAY RESULT. FOR YOUR SAFETY, FOLLOW THE INSTALLATION DIRECTIONS. CONTACT LOCAL BUILDING OR FIRE OFFICIALS ABOUT RESTRICTIONS AND INSTALLATION INSPECTION REQUIREMENTS IN YOUR AREA.

The Harman TL300 meets the U.S. Environmental Protection Agency's emission limits for wood heaters sold after July 1, 1990.

Specifications

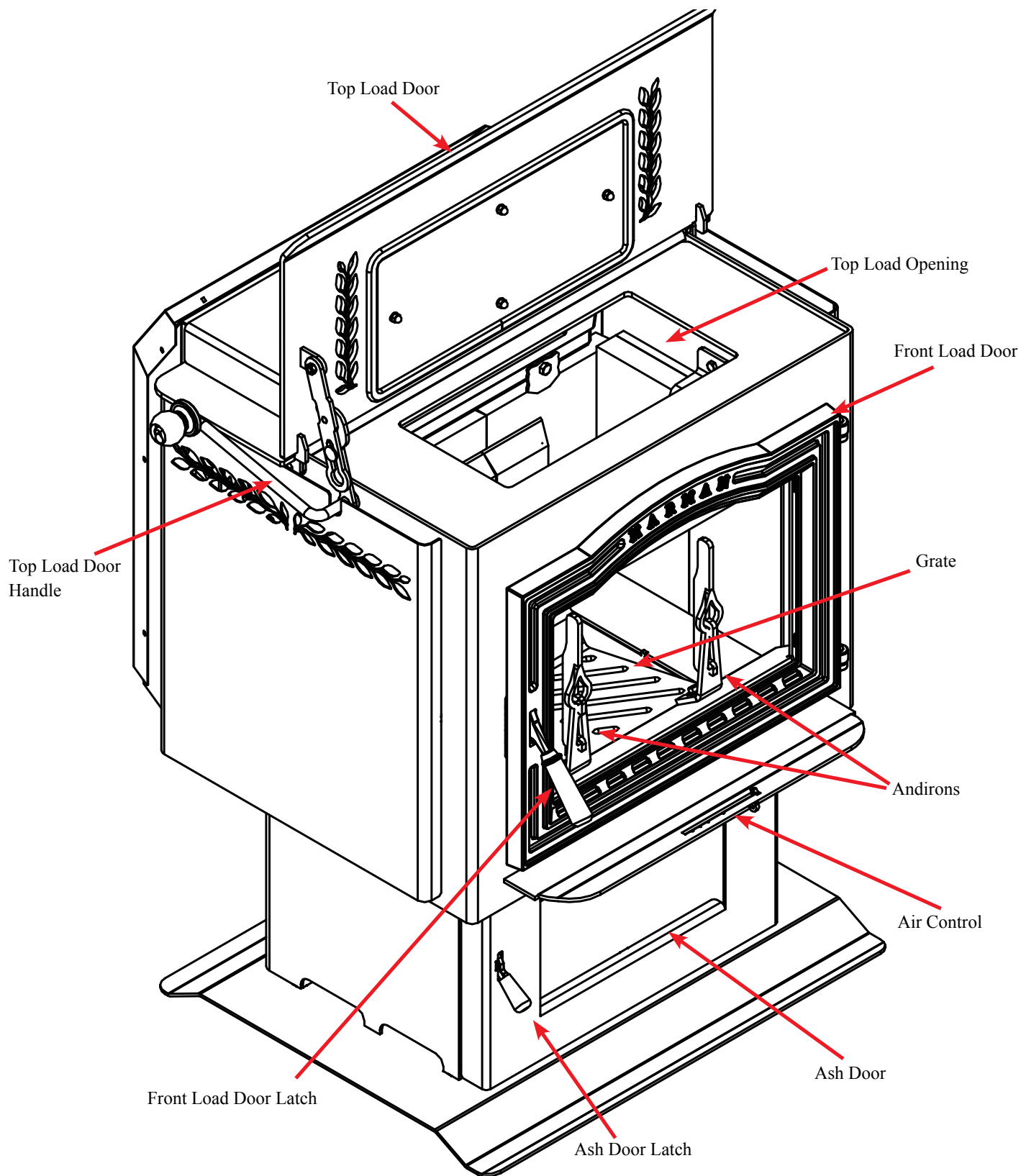

Specifications

General Considerations

Draft

Before you install and/or operate your TL300 wood stove, please read the entire contents of this manual. Pay particular attention to the explanation of draft and its effect on stove performance, in the installation section. By following the installation and operating guidelines, you will ensure proper draft and gain maximum efficiency and enjoyment from your stove.

Fuel

Your TL300 burns wood very efficiently. Here are some guidelines concerning log size and moisture content that will help you obtain the best performance.

Select dry seasoned wood. For example, it should be checked or cracked on the ends and not exposed to rain or extremely damp conditions. Hardwoods are favored because they are heavier and contain more heating capacity (BTU's) per load than do softwoods. Wood should be split and stored under cover for "seasoning" - a year is recommended. Your stove is not an incinerator - do not burn garbage, painted or treated wood, plastics, or other debris.

Keep the area around the stove free from clutter. Keep all combustibles, including fuel, beyond the code-required clearance distance (48" or 1215 mm in the U.S., 1525 mm or 60" in Canada). Never store fuel in front of the stove where it could interfere with door operation, safe loading, and ash removal.

Do not burn garbage or flammable fluids such as gasoline, naphtha, or engine oil.

NEVER OPERATE WITH MORE THAN ONE DOOR OPEN AT A TIME.

CAUTION:
Always wear fire retardant gloves when operating the stove.

SAFETY NOTICE
IF THIS HARMAN TL300 STOVE IS NOT PROPERLY INSTALLED, OPERATED AND MAINTAINED, A HOUSE FIRE MAY RESULT. FOR YOUR SAFETY, FOLLOW INSTALLATION DIRECTIONS. CONTACT LOCAL BUILDING OR FIRE OFFICIALS ABOUT RESTRICTIONS AND INSTALLATION INSPECTION REQUIREMENTS IN YOUR AREA.

The Stove

Doors

Your stove has a large glass-paneled door for loading and fire viewing, a separate smaller door for removing ashes, and a top loading door.

Front Door

Before opening, always check for wood, embers, or ash that may be ready to fall out of the door.

To open the glass door, open bypass damper first, by pulling forward on the top load door handle, to the first position. Then lift up on the front door handle to disengage the latch, and pull out. To close the door, push door closed with handle in the open position, then push handle down to engage the latch.

Ash Door

To open the ash door, open the bypass damper first. Lift up on the ash door handle and pull it open. Close the door by pushing in and pushing the handle all the way down.

Top Load Door

To open the top load door, pull forward on the top load door handle. The first position tells you the bypass damper is open. Continue pivoting the handle toward you until it locks the top load door open.

All doors must be closed while the stove is in normal operation, and the gaskets routinely examined for wear and replaced when necessary. Good door seals are important for maintaining control of the stove. Never operate with the ash door open. Operating the stove with the ash door open, or with a door improperly sealed, could create a serious overfiring condition (discussed later in this section).

The glass used in your TL300 is manufactured to exact standards to withstand the high heat of the fire, but like all glass, it must be treated with common sense and care. Never abuse the glass by slamming the door shut or striking the glass with a heavy object. If the glass is broken or damaged, do not operate the stove until it has been replaced (See instructions in Maintenance section.)

Grates

The Harman TL300 has a unique grate system that consists of one bottom grate, and two front andirons. The bottom grate has slots which allow the ash to fall into the ash pan by passing a poker back and forth across the grate. The andirons keep the fuel from coming into direct contact with the glass, and keep hot coals and embers from spilling out while reloading. Never build a fire directly against the glass. Andiron extensions (included with each stove) clip onto the fixed andirons and serve to protect the glass when top loading is used as the primary loading method. The grates and andirons must remain in place at all times. Do not tamper with or change the configuration of this grate system.

Installation

Clearances

Clearance is the empty space required between the stove or chimney connector and the nearest combustible surface or object, such as walls, ceilings, floors, or furniture. Clearance distances may only be reduced by using methods approved by either the CAN/CSA B365 standard (Canada) or NFPA 211 (U.S.) Contact your building authority for information if you are interested in reducing clearance distances below those presented here.

Parallel versus Corner Installations

A parallel installation is one in which the back and sides of the stove are parallel to the walls behind and to the side of the stove. A corner installation is one in which the back of the stove is positioned diagonally across a corner of the room. Each installation requires its own set of clearances.

For parallel installations, the required clearance distances from the stove are:

- 1) to the side wall, 20" (508 mm);
- 2) to the back wall, 18" (458 mm).
- 3) From the chimney connector to the wall, 31"(787 mm)
- 4) Horizontal pipe to the ceiling, 15"(381 mm).

NOTE: For a vertical chimney connector in a parallel installation the distance from the connector to the side wall must be 31"(787 mm), due to the required side clearance of the stove itself. Fireplace installations must meet these same clearance requirements; specifically follow these guidelines for mantel and trim clearances.

For corner installations, the clearance distances from the stove are 18"(458 mm) from each corner of the stove measured straight to the nearest combustible material, and 27" (686 mm) from the chimney connector to the walls.

From the front of the stove, clearance to combustible materials such as furniture, curtains, fuel, etc.: 48"(1220 mm) in the *U.S.* and 60"(1524 mm) in *Canada*. Due to excessive heat build-up at the wall passthrough, using double wall pipe, horizontal venting is only approved into a masonry chimney.

See Detailed Clearances on Page 9

Floor Protection

Floor protection is required under your TL300. This floor protection must be a minimum of 20 ga. sheet metal in thickness, it can also be stone or tile or other masonry material, providing it is non-combustible. This floor protection must extend 18 inches in front of the door opening and 8 inches to each side and to the rear of the stove body. There must also be floor protection under any horizontal sections of venting regardless of their height from the floor.

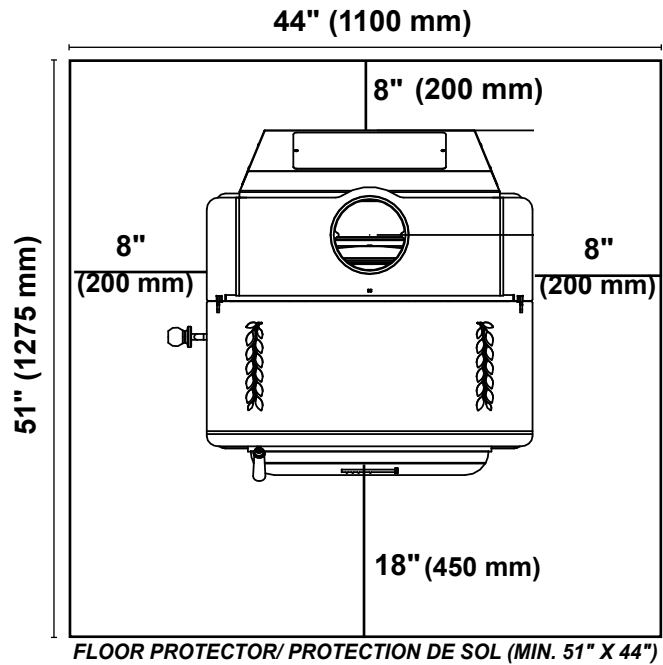

Mobile Home Installation

The TL300 is approved for mobile home installations in the US only. Mobile Home installation should be done in accordance with the Manufactured Home and Safety Standard (HUD), CFR 3280, part 24.

When installing the TL300 in a mobile home, several requirements must be met:

1. The unit must be bolted to the floor. This can be done through the rear of the pedestal with 3" lag screws, using the holes where the unit was bolted to the shipping pallet.
2. The unit must be connected to outside air. See Outside air section on page 21.
3. Floor protection and specified clearances to combustibles must be followed.
4. Unit must be grounded to the metal frame of the mobile home.
5. Smoke detectors and/or smoke alarms are recommended on each floor of the house. Note that when loading fire, some smoke seepage may occur, and set off the alarm. Ventilate as necessary to eliminate the problem. If the alarm should sound otherwise, cease the use of the appliance and call your dealer for service.

MOBILE HOME REGULATIONS DO NOT ALLOW INSTALLATION IN ANY ROOM DESIGNATED FOR SLEEPING.

Installation/Clearances

Single Wall Pipe - Parallel Installation

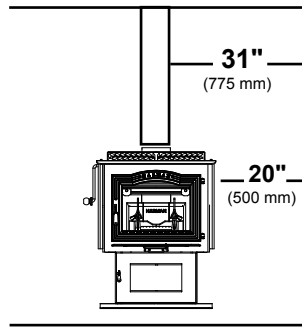

Top vent ceiling and sidewall clearances

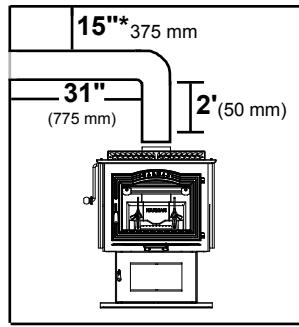

Top Vent to vented out side wall with 90° elbow

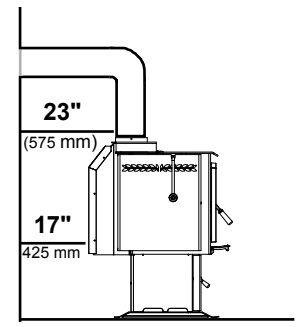

Top vent vented out back wall with 90° elbow.

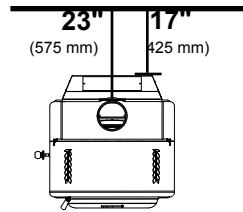
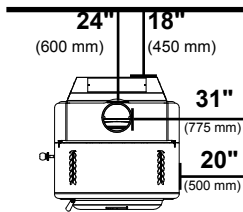

Double Wall Pipe - Parallel Installation

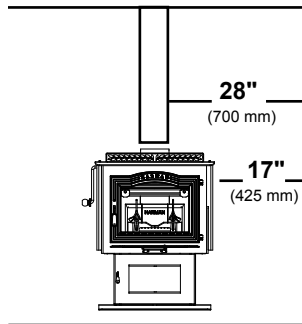

Top vent ceiling and sidewall clearances

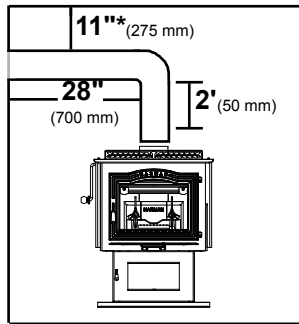

Top Vent vented out side wall with 90° elbow.*Masonry Chimney Only.

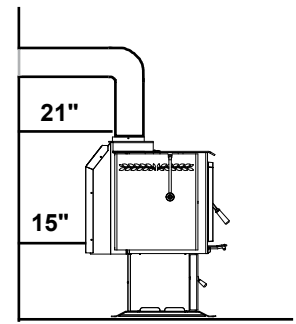

Top vent vented out back wall with 90° elbow.*Masonry Chimney Only.

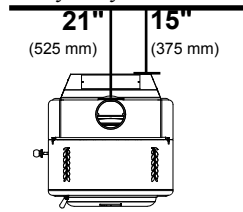
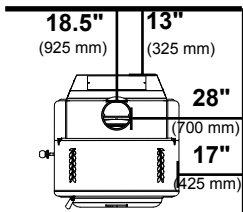

Corner Installation with Single and Double Wall Pipe

Single Wall Pipe

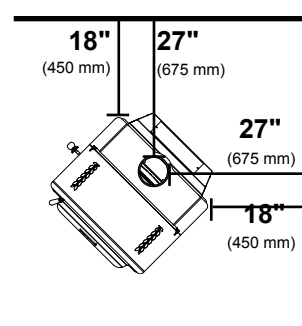
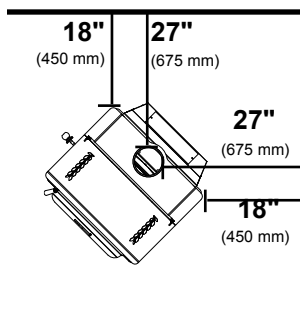

*Check with your local building codes for clearance.

Venting

Chimney Connectors and Chimneys

Draft

Draft is widely misunderstood. It is important that you, the stove operator, realize that draft is a variable *effect*, not a given quantity. Stoves and chimneys do not *have* draft, yet draft is the key to your stove's performance.

Draft is a force, produced by an operating stove and the chimney to which it is attached. It is created by hot gases rising up the chimney, creating a pressure difference between the inside of your home and the outside air. It continually moves fresh combustion air into the stove, and hot exhaust gases out of the stove; without this constant flow, the fire will go out.

Other factors, such as barometric pressure, winds, the tightness of the home, the total inside chimney volume, chimney height and the presence of venting devices such as exhaust fans also play a role in maintaining an adequate draft. Low barometric pressures, super insulated homes, and exhaust fans can reduce draft; winds can play havoc with draft; and too large or too small a chimney volume can cause reduced draft due to the excessive cooling or not enough room to vent the exhaust gases. Introducing outside air directly to the stove may help remedy a low draft problem. Some signs of inadequate draft are smoking, odor, difficulty in maintaining the fire, and low heat output. Overdraft can be caused by a very tall chimney even if it is the recommended size, and can cause overfiring of your stove. Signs of an overdraft include rapid fuel consumption, inability to slow the fire, and parts of the stove or chimney connector glowing red. It is important that you follow the chimney guidelines in this manual, including size, type, and height to avoid draft problems.

When installed and operated according to this manual, the TL300 will produce enough hot gases to keep the chimney warm so that adequate draft is maintained throughout the burn cycle.

Chimney Connectors

In general, following these guidelines will ensure compliance with all national and provincial codes; prior to beginning your installation, check with your local building code official(s) regarding any additional local requirements or regulations which may influence the design and placement of your venting system.

The Harman TL300 may be installed with (.6 mm) 24 gauge chimney connector pipe. The size of the connector should correspond to the size of the flue collar opening. Do not use makeshift components.

No part of the chimney connector may pass through an attic or roof space, closet or other concealed space, or through a floor or ceiling. Whenever possible, avoid passing the connector through a combustible wall; if you must, use an approved wall pass-through, described later in this section.

Assemble the connector beginning at the flue collar, with the crimped ends pointing towards the stove (to keep debris and creosote flakes inside the system). Each joint, including the one to the stove's flue collar and the one to the chimney itself should be secured with at least three sheet metal screws. Screws may be a maximum of 3 inches apart. A 1-1/4" (32 mm) overlap is required at each joint, including the flue collar attachment. No more than two 90 degree elbows should be used, and the total length of connector should not exceed 10 feet (3m) All horizontal runs of connector must have a minimum upward slope of 1/4 inch per foot (20 mm per meter).

Wall Pass-thrus

Occasionally it is necessary to pass the chimney connector through a combustible wall to reach the chimney. Depending on your local building codes, and the pertinent provincial or national codes, there are several choices for accomplishing this safely. Before beginning your installation, contact local officials, and also the chimney connector and chimney manufacturer for specific requirements.

Canada. Three methods are approved by the Canadian Standards Association. The diagram shows one method requiring an 18" (460 mm) air space between the connector and the wall. It allows use of one or two covers as described in the diagram. The other two methods are described in detail in the current issue of CAN/CSA B365, the national standard.

United States In the U.S., the national code is NFPA 211. While many localities adopt this standard, be sure to check with local authorities before beginning your installation.

The NFPA (National Fire Protection Association) permits four methods for passing through a combustible wall. A commonly used method to pass through a wall directly to a masonry chimney is to clear a minimum 12"(305 mm) around the entire chimney connector, and fill it with brick masonry which is at least 3.5"(90 mm) thick. A fireclay liner, minimum 3/8" (9 mm) wall thickness must run through the brick wall to the chimney liner (but not beyond the inner surface of the liner). It must be cemented in place with refractory cement. This method is illustrated. For details on the other three options, refer to the most recent edition of the NFPA 211 code.

Venting

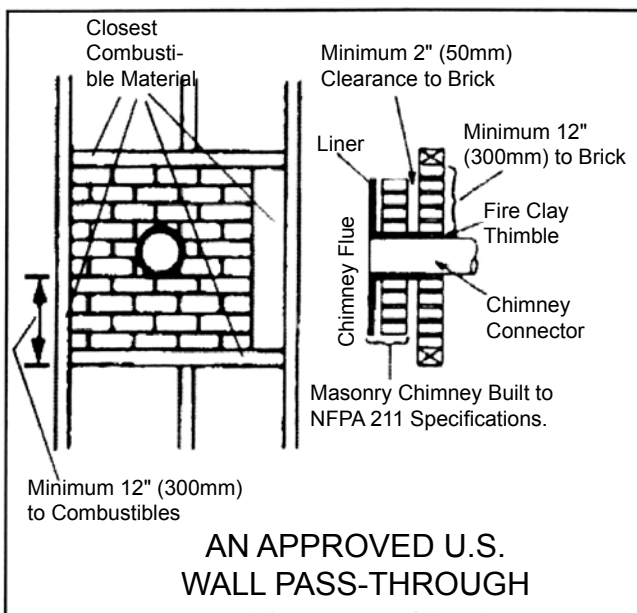
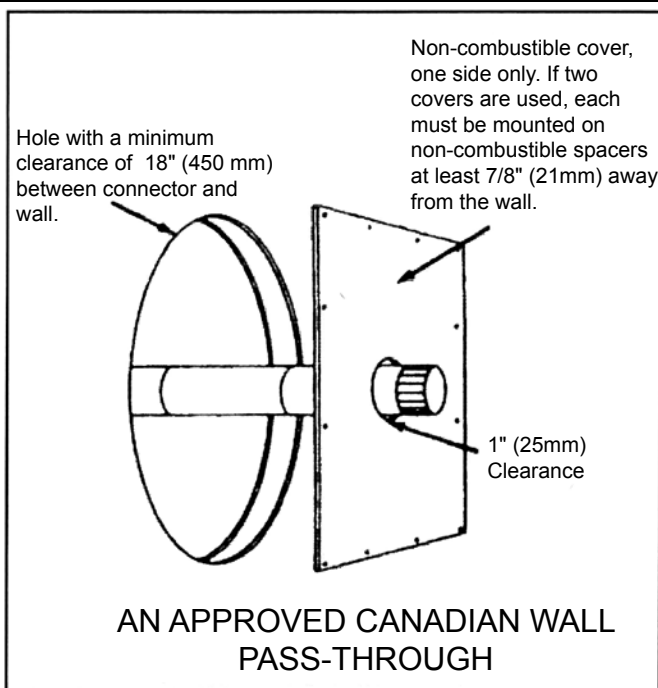

The Chimney

The TL300 must be installed into a chimney approved for use with solid-fuel appliances. In the U.S., the TL300 must be connected to (1) a prefabricated chimney complying with the requirements for Type HT chimneys in the Standard for Chimneys, Factory-Built, Residential Type and Building Heating Appliances, UL 103, or (2) a code-approved masonry chimney with a flue liner.

In Canada, the TL300 is listed for use with prefabricated chimneys tested and listed to the high temperature (650 degrees C) chimney standard, ULC S-629, or with a code approved masonry chimney.

For mobile homes, (US only) the TL300 must only be installed with prefabricated chimney systems, including the installation components, tested to use in mobile homes; the diameter should match the diameter of the flue collar opening

The minimum recommended height for any chimney is 16 ft (4.8 m) above flue collar height. For non-mobile home installations, a round flue (either masonry or approved prefabricated), of either 6" (150 mm), 7" (180 mm) or 8" (200 mm) may be used. For square or rectangular masonry chimneys, nominal sizes of 8" x 8" or 8" x 12" (200mm x 200 mm, 200 mm x 300 mm) may be used.

Codes require that solid-fuel chimneys extend 3 ft (0.9 m) above the highest point at which they exit from the roof. Then, the chimney must extend 2 ft (0.6 m) above the highest point within a 10 ft (3 m) radius. Thus, the 3 foot, 2 foot, 10 foot rule:

- 3ft.** - Above roof exit point
- 2ft.** - Higher than anything within-
- 10ft.** of the chimney.

Do not connect this unit to a chimney flue servicing another appliance.

NOTE: The restriction of not venting more than one appliance to the same flue applies to the U.S. specifically. While it is not recommended that you use the same chimney for more than one appliance, in *Canada* certain exceptions may be made. Be sure to contact your building code inspection official to see if this option is allowed in your area, and to find out the specific requirements for such an installation.

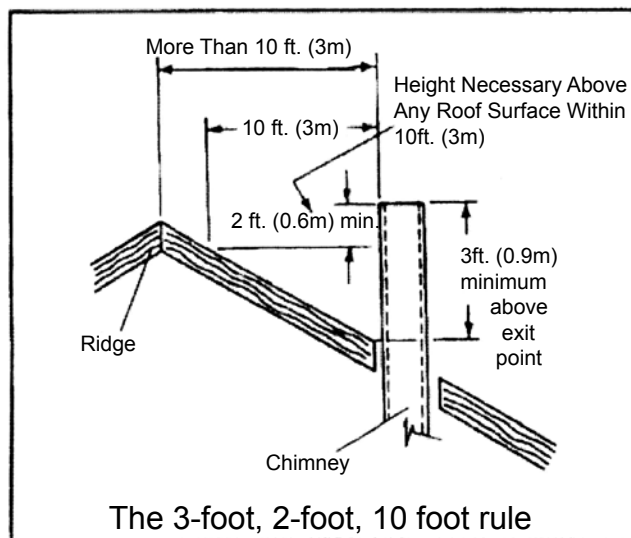

Venting

Existing Masonry Chimneys

If you plan on using a pre-existing masonry chimney, have it thoroughly inspected and cleaned. Any faults which make the chimney unsafe and unusable must be repaired prior to use. These can include improper height, structural defects, blockages, inadequate clearance to combustibles, unsealed openings into other rooms of the house, signs of creosote or smoke leakage, a loose or absent clean-out door, or absence of a liner.

Do not connect to any air distribution duct or system

Venting to a Masonry Chimney

When connecting to a masonry chimney, several provisions are standard. First, whether the chimney connector is vented to the chimney through a thimble or a breech pipe, neither must pass beyond the inner surface of the chimney liner, and both must be firmly cemented in place with refractory cement. (A thimble is a masonry pipe which is inserted through the chimney wall, and is frequently the preferred method; a breech pipe is a piece of steel pipe used the same way.) In Canada, a breech pipe has ridges or protrusions to lock it firmly into the refractory cement. In either case, the chimney connector vents to the chimney through the thimble or breech pipe.

Using a thimble, the connector slides completely inside the masonry to the inner edge of the flue liner, and may be easily removed for chimney and connector inspection. A breech pipe must extend at least 2" (50 mm) into the room, so the connector can be attached with sheetmetal screws.

Venting to a Masonry Fireplace Chimney

In some situations, a code compliant chimney originally used for a masonry fireplace may be used to install your TL300. In addition to the requirements found in the previous paragraphs, it is important to be aware that all clearances must be met, including those from the chimney connector to combustibles. Do not forget to include floor protection in your plans. (See Clearances and Floor Protection in this section.) Since many fireplaces have exposed wooden mantels and trim, pay special attention to the clearances necessary to these materials.

If your fireplace chimney is behind a combustible wall, you must use an approved wall pass-through system to gain access to the masonry chimney. The chimney connector must enter the chimney at a place where it is lined, and the fireplace must be made inoperable. For example, you might remove the damper, replacing it with a secure, airtight, noncombustible seal (removable for inspection); this also satisfies the requirement that no room air must be allowed to enter the chimney.

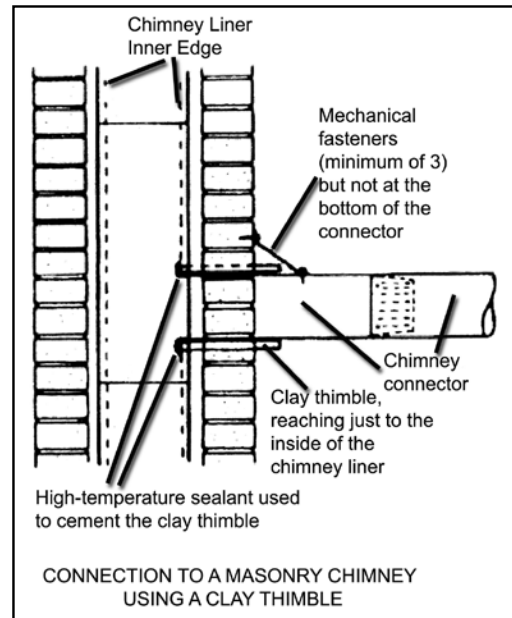

Do not burn any fuel other than wood, such as charcoal, which can cause increased carbon monoxide production or overfiring. Never use highly volatile substances in your stove, such as gasoline, which could cause an explosion.

When solid fuels are burned completely, they produce water and carbon dioxide. However, in long slow burns, a substantial amount of carbon monoxide may be produced. If allowed to build up, carbon monoxide (which is odorless) can prove fatally poisonous. Proper ventilation and draft will prevent this from happening. If you smell smoke, turn up the air control lever setting, and thoroughly ventilate your dwelling. During future burns, be careful not to overload the stove with fuel, so you will not be tempted to constantly operate at a low air control setting.

Other causes of poor ventilation or draft are icing, exhaust fans, a blocked outside air inlet, and room air starvation. If your stove is sluggish and you get occasional odor, check these possibilities and increase the air flow in your home.

Installing to a Prefabricated Chimney

When venting your TL300 using a prefabricated chimney, be sure to contact local building code authorities, and to follow the manufacturer's instructions exactly. Use only the manufacturer's parts; do not use makeshift installation techniques. All prefabricated chimneys must be tested to either the U.S. or Canadian high-temperature standards, UL 103 or ULC S629.

The Harman TL300 was tested with the fuel door open and closed. Keep door closed for normal operating conditions. If you operate with the door open, open the by-pass damper and put a screen over the door opening.

Venting

Standard Ceiling Installation with Factory Built Chimney

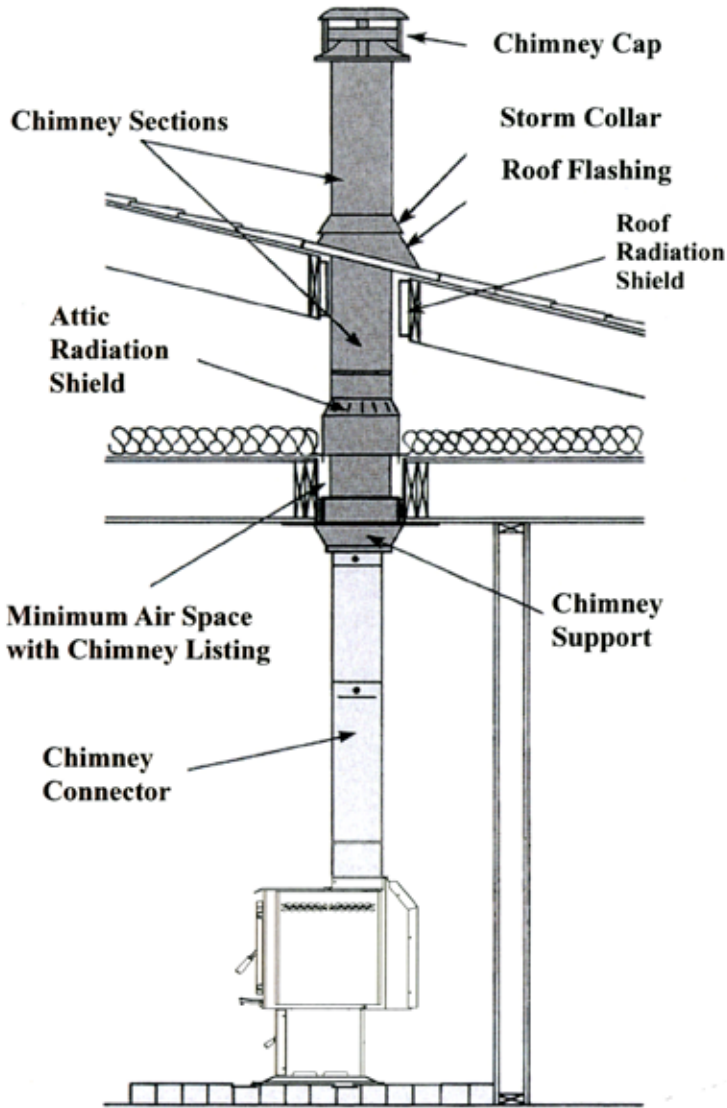

Cathedral Ceiling Installation with Factory Built Chimney

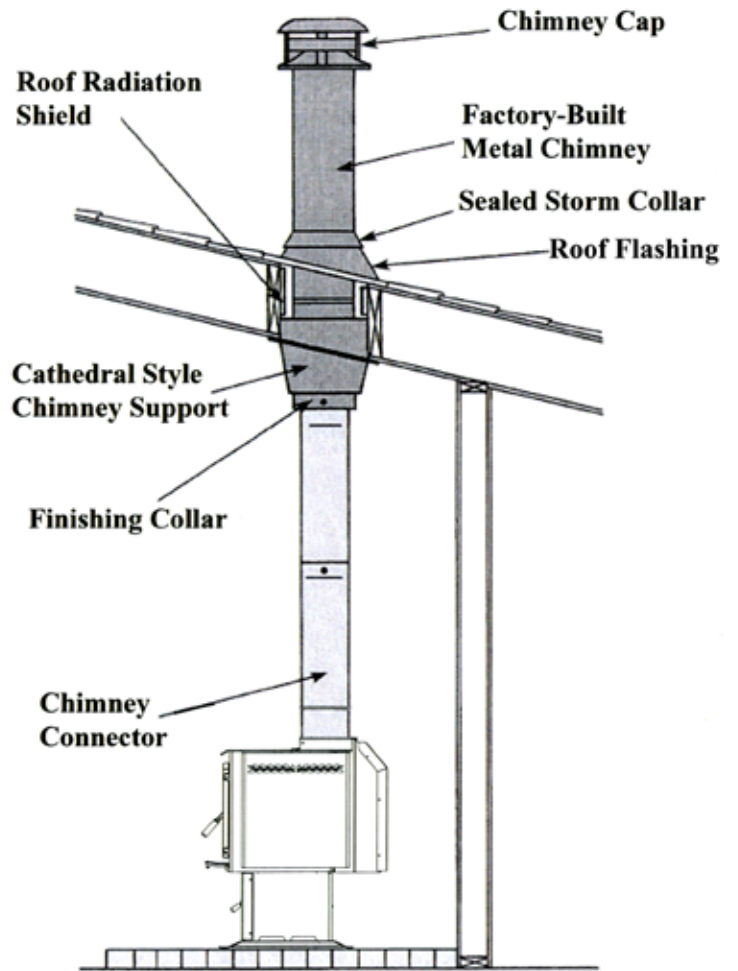

Venting

Chimney Breach Fireplace Conversion with Non-Combustible Wall

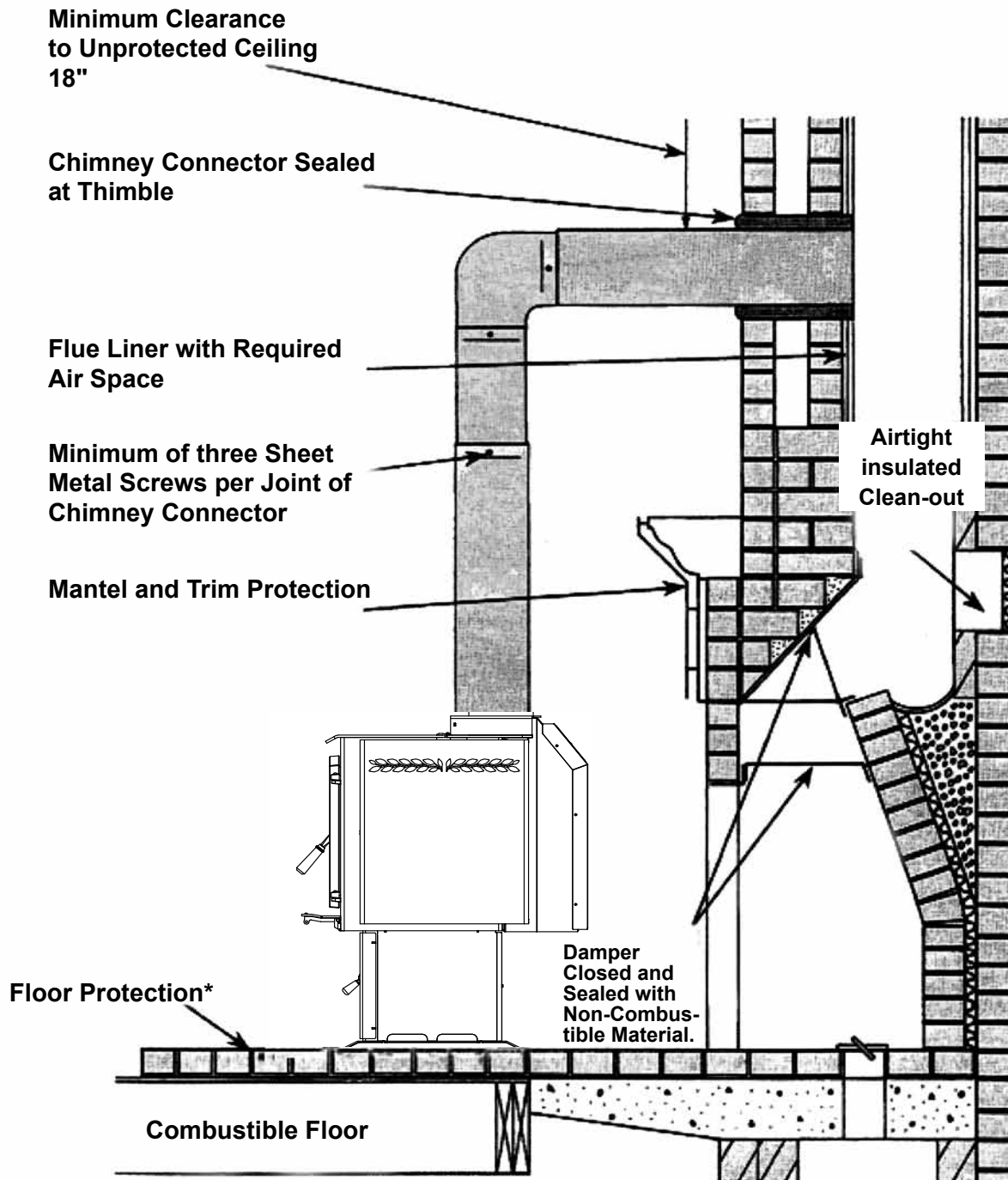

* Floor Protection in Accordance with Solid Fuel Appliance Listing

Venting

Chimney Breach Fireplace Conversion with Combustible Wall

Minimum Clearance from
Chimney Connector to
Unprotected Ceiling

15"***

Flue Liner with Required Air Space

Listed or Approved Thimble Assembly

1" Clearance for Exterior
Chimney or 2" Clearance
for Interior Chimney and
2" Clearance for NFPA 211-
Type Approved Thimbles

Combustible
Wall

Sheetrock

Airtight
insulated
Clean-out

Mantel &
Trim
 Protec-
tion

Damper Closed
and Sealed
with Non-
combustible
Material.

Floor Protection*

Combustible Floor

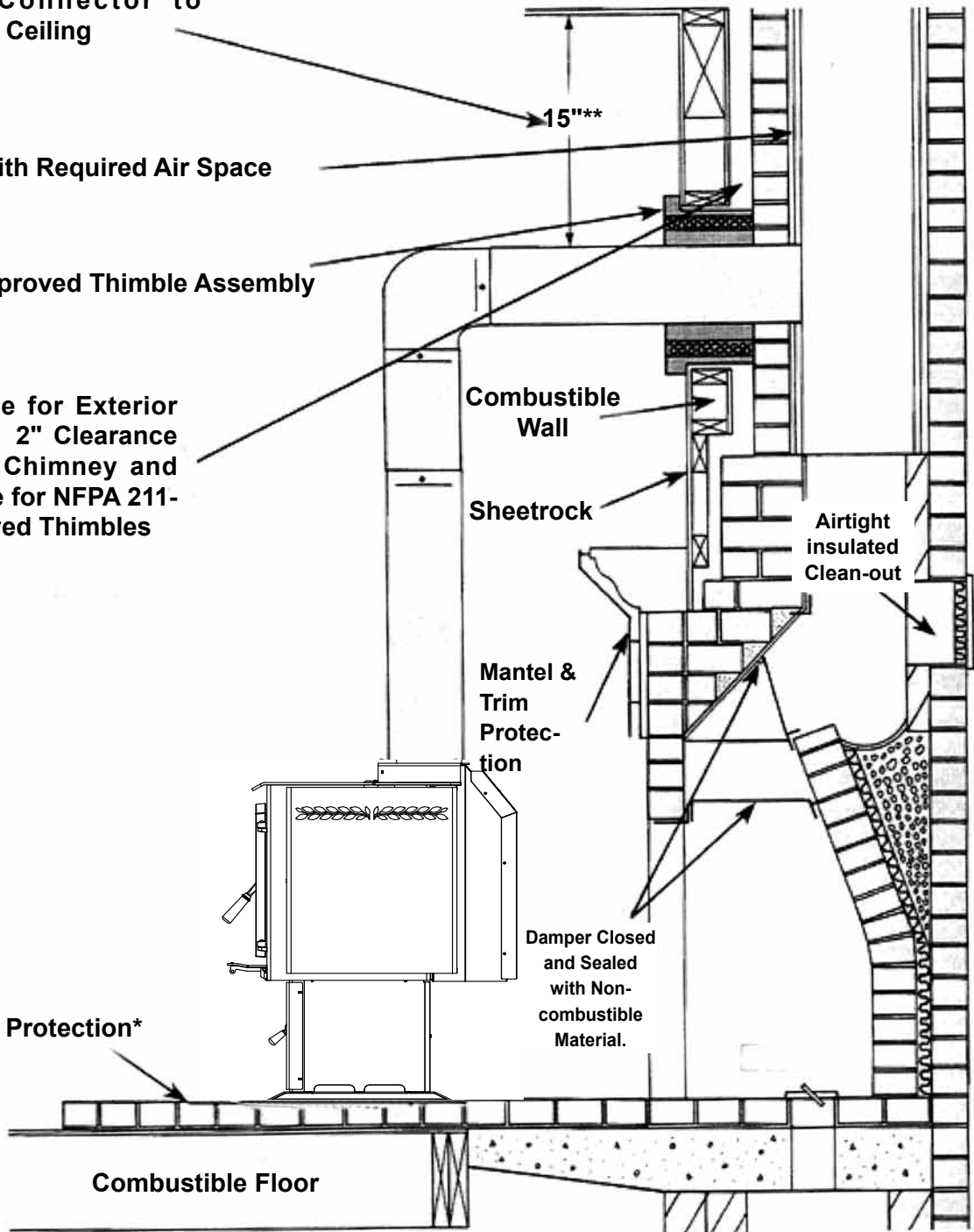

* Floor Protection in Accordance with Solid Fuel Appliance Listing

** Check with your local building codes for clearance.

Operation

The Combustion Process

Combustion in the Harman TL300 is precisely controlled and is divided into two parts.

During combustion, primary air enters at the bottom front of the stove and travels up channels at either side of the front door. This pre-heated air then enters the manifold, located above the front door, where it is released into the firebox as a sheet of air between the glass and the fire. This air-wash system cleans the glass as it provides oxygen to the firebox.

Secondary combustion air enters the stove at the bottom rear of the stove. Here, in the "Firedome", it mixes additional oxygen with the exhaust, causing it to be re-burned. This secondary combustion is necessary to achieve and sustain long, clean burning.

During combustion, the burning of wood proceeds through several stages. The initial or evaporation stage is where the moisture in the wood is driven off in the form of steam. During the second stage, the volatile gases contained in the wood are released and burned. This represents most of the wood's heating capacity. The final stage is the charcoal stage where the charcoal burns the remaining heat content out of the fuel. Ash remains after the burning is complete. Within the primary firebox, two or more of these stages of combustion are occurring simultaneously.

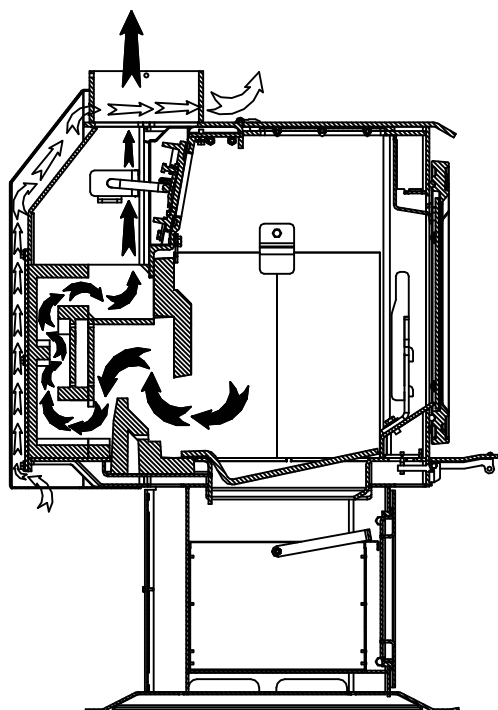

Two important controls - the top load door handle and the air control lever regulate the operation and output of the stove.

Top loading door handle/damper interlock. The top loading door handle is linked to the bypass damper and serves two purposes. Move the handle forward one position (approximately 3") and the handle automatically opens the bypass damper, you must open the bypass damper, or smoke will come into the room. In this mode of operation the combustion gases go directly from the main combustion chamber to the flue collar and exit into the chimney.

Continue moving and lifting the handle and it opens the top loading door.

NOTE: The bypass damper must be open for smokeless loading. Open the bypass damper by pulling the handle toward the front of the stove.

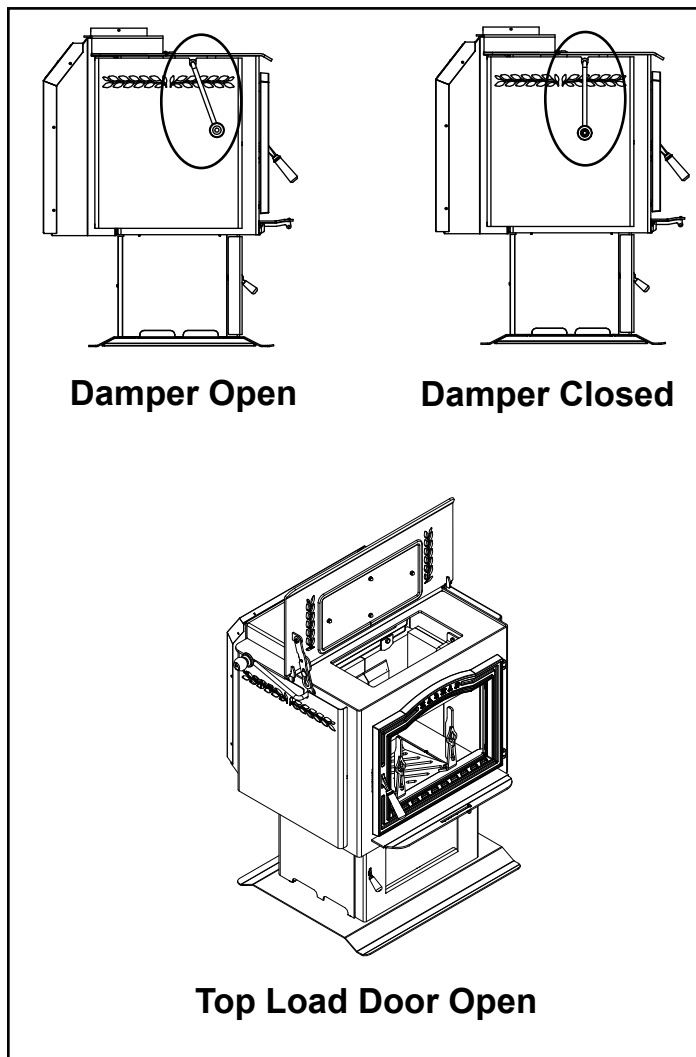

Building a Fire

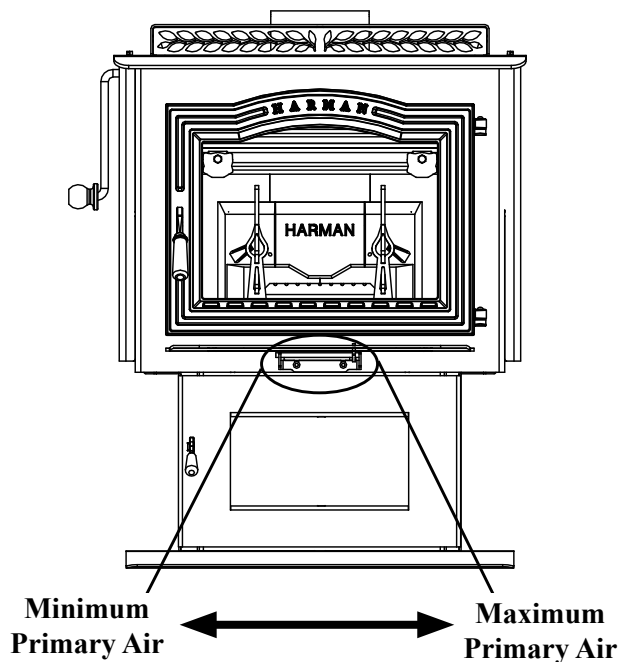

Air Control

The air control lever is located directly below the ash lip of the stove. Using this lever will enable you to vary the amount of air delivered to the fire, creating a range of heat outputs. The low heat output setting is to the left, and high is to the far right. Do not, under any circumstances, alter the configuration or operation of the air control lever.

For low burn, slide the air control to the leftmost notch. For medium burns, use notches 2 or 3. Maximum heat is attained with the air control all the way to the right. **Do not burn the stove continuously at the maximum setting. If maximum heat is required day after day, the stove is too small for the area you are trying to heat and damage will occur to the stove.**

If your wood is not seasoned long enough or is high in moisture, you may have to adjust the primary air 1 or 2 notches higher to sustain a low burn rate with the cleanest possible exhaust.

Blower

To regulate the speed of the optional convection blower, adjust the variable speed control from low to high by turning the knob located on the blower. The blower speed should be matched to the air control lever setting. When the air setting is low, the blower should always be at the minimum setting. At high settings, above the first notch on the air control, the blower may be set to your desired control level. Be sure the blower cord does not run under, over, or in front of the stove.

Building and Maintaining the Fire

Do not use chemicals or fluids to start the fire.

Never use gasoline, gasoline-type lantern fuel, kerosene, charcoal lighter fluid, or similar liquids to start or "freshen up" a fire in this heater. Keep all such liquids well away from the heater while it is in use.

Begin with the bypass damper open, and the air control lever at the maximum setting, all the way to the right. Be sure the ash pan door is closed and latched.

Start with a bed of crumpled paper and kindling sized about finger width; place several 1" - 2" (25mm - 50mm) split pieces of dry wood on top of the kindling, followed by a few 2" - 3" (50 mm - 80 mm) split pieces. Lay the wood in a crossed pattern to allow maximum air flow. Ignite the paper and close the loading door(s). Allow this start-up fire to burn for a few minutes, keeping the bypass damper open. Add about five more pieces of wood in the 2 to 3 inch (50 - 80mm) size range, making sure that the fuel bed is all the way across the firebox and staggered to allow airflow. Close the door and allow this loading to burn a few minutes.

Add increasingly larger pieces of wood to the fire until you have a thick bed of hot embers, approximately 2 to 3 inches deep at the back of the grate and at least an inch deep at the front. **You must have this charcoal bed established before you close the bypass damper.**

Providing you have the charcoal bed described above, close the bypass damper by pulling the handle toward the front of the stove. This will begin the highly efficient mode of operation where the exhaust gases get re-burned in the secondary combustion package. If you cannot achieve a charcoal bed within the first 15 to 20 minutes, your wood is likely too wet, and you may need to burn the fire longer and/or hotter to compensate for the extra energy needed to drive out the moisture.

If, after five minutes of burning with the damper closed, smoke is visible coming from the chimney, you probably do not have the proper coal bed. Open the bypass damper and continue with the process until a significant coal bed is formed.

Building a Fire

Building and Maintaining the Fire Cont.

Always remember to open the bypass damper when you are loading, this allows the exhaust gases to pass directly into the flue outlet and reduces the chance of smoke spillage into the room.

Reloading: Once you have prepared and maintained a thick charcoal bed, and the secondary combustion is established, you should be able to reload the stove at any time by simply opening the bypass damper, then the load door, adding fuel and closing the door then the damper. This depends on coal bed size, load size and moisture content of fuel.

Removing Ashes: Before reloading, empty the ash pan (remember to close the ash door while emptying the pan). The ashes should be the coolest at this time. Remove ashes from the fire chamber periodically by raking a poker across the bottom grates.

Excessive ash buildup can prevent proper venting of exhaust gases. Do not allow the ash pan to over-fill. Ash buildup between the ash pan and the bottom of the grate can cause the grate to overheat and wear out prematurely.

The TL300 was designed to allow access to the ash pan without the need for opening the main door. Before opening the ash door and removing the ash pan, open the bypass damper. Wearing heavy protective gloves, open the ash door and remove the ash pan by pulling it forward by the handle. Close the ash door and damper bypass before taking the ashes outside for safe disposal.

Ashes should be placed in a metal container with a tight fitting lid. The closed container of ashes should be placed on a noncombustible floor or on the ground, well away from all combustible materials, pending final disposal. If the ashes are disposed of by burial in soil or otherwise locally dispersed, they should be retained in the closed container until all cinders have thoroughly cooled. (This could take days).

Never use the ash disposal container for other trash. Wood ash can be added to your garden or compost.

Avoid overfiring your stove.

Overfiring is a potentially hazardous situation which can lead to overheating of combustible materials, damage to the stove, and in extreme cases, cause a fire.

Overfiring is caused by:

1. Too much air flowing through the stove too quickly.
2. You may have positioned the primary air control lever too far to the right.
3. Inadvertently leaving the damper or ash pan door open
4. Not keeping up with routine maintenance, such as checking door gaskets for wear.

Overfiring results in excessive fuel consumption, and may cause parts of the stove or chimney connector to glow red. If you notice signs of overfiring, reduce the air supply to the fire, and review the Maintenance section in this manual.

IN THE EVENT OF A CHIMNEY FIRE, call your local fire department; make sure everyone is safely out of the house. Reduce the air intake of the stove as much as possible using the air control lever; close the bypass damper to further restrict air flow. Do not throw water on the fire; this can cause stove damage and create an even more dangerous situation. Have your chimney professionally cleaned and inspected before relighting your stove.

As you begin to operate your stove at higher temperatures, you will notice a "hot" or unpleasant smell; this is just the paint going through the curing process, and will disappear after a few fires.

CAUTION

The stove is hot while in operation. Keep children, clothing and furniture away. Contact may cause skin burns.

Never leave the stove unattended if either the ash or load door is open. Overfiring may result.

Risk of Excessive Temperatures. Keep Ash Door Closed During Firing of the Heater.

CAUTION: Always wear fire-resistant gloves to operate the stove. The air control is hot while in operation.

Maintenance

Like all fine equipment, your TL300 requires some routine maintenance and inspection. Follow the guidelines in this section to assure safe, efficient operation.

The Stove

Surface

The stove's exterior surface should be dusted periodically with a soft cloth. For more thorough cleaning, wait until the stove is cool before using a damp cloth to clean any blemishes.

Controls

To avoid a rust build-up on the inner surfaces of the controls, work the controls back and forth several times during the summer or any prolonged period when you are not using your stove.

The Fire Chamber

The inside of the fire chamber should be examined for damage to the refractory lining material, grates, and casting. If any bricks have been damaged, replace them with Harman replacement parts. Be sure that all air holes in the refractory are open. The Firedome combustion package can be examined and/or cleaned with the bricks removed.

NOTE: Be sure not to insert anything such as a fire poker into the Combustion Package. Doing this may cause damage to the combustion package. See below.

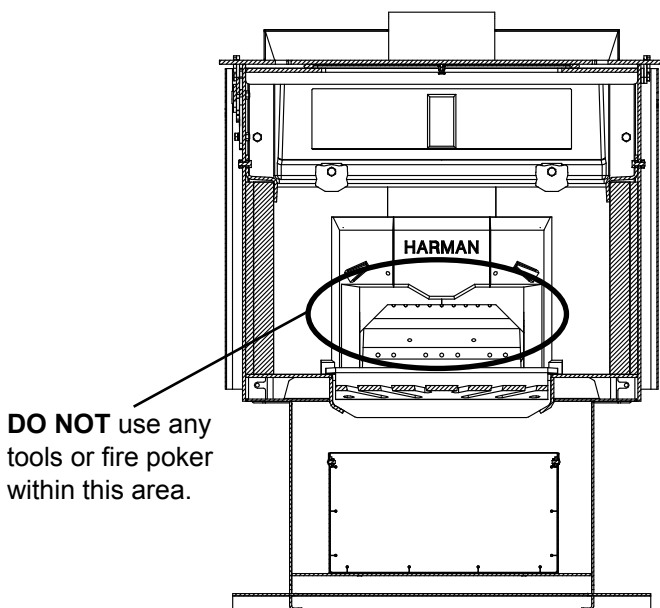

Glass - Replacement

If the stove's glass is cracked or broken, you must replace it before operating your stove. Remove pieces carefully. Replace glass only with Harman replacement glass; do not use substitutes.

To replace the glass panel, you will need to remove the door. To do this, open the door, lift it straight up and place it on a soft surface.

Carefully remove damaged glass, gasket material, and hold down clips (set aside).

Referring to the diagram, note how the various components of the door system fit together. Lay the load door face down on the soft surface, and install the self adhesive 1/4" gasket material around the front face of the glass. Note: this glass has a special IR coating on one side. This coating must be to the **outside** of the stove. The coated side has a label on it and/or will show resistance on a ohm meter.

Set the glass panel and gasket gently onto the door. Install the hold down clips and tighten with bolts as shown. Reinstall door on stove.

Glass - Cleaning

Sometimes it will be necessary to clean accumulated ash from the glass surface; allowing this ash to remain on the glass for long periods can result in "etching" due to the acidity of the ash. The creosote which accumulates on the glass should burn off during hot fires.

Never clean the glass while it is hot, and **do not** use abrasive substances. Wash the surface with cool water, and rinse thoroughly. You may wish to use a non-abrasive cleaner specifically designed for use on stove glass. In any case, dry thoroughly before relighting your stove.

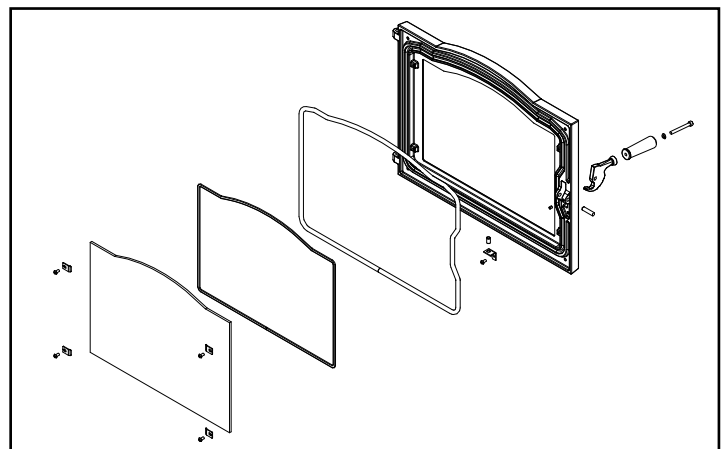

Maintenance

Gaskets

Gaskets are used at strategic positions when building the Harman TL300 for controlling the path that incoming and outgoing air and gases take through the stove. You must check these gaskets from time to time and replace them when necessary. The gaskets are made of fiberglass of different sizes (obtainable from your Harman dealer) and some are fixed in place with a high temperature stove gasket cement. To change a gasket, first remove the worn fiberglass and clean the area with a wire brush. Also clean any other surfaces that come into contact with the gasket. Place a small bead of cement in the area under the gasket if required, then press new gasket material into the channel; do not overlap the ends. Seat the gasket firmly by applying pressure when possible; for example, after changing the door gasket, close the door. Allow the cement to dry before using your stove.

Gaskets are located:

- On the doors to provide airtight closure.
- Between the damper and the damper frame.
- Rear cover
- Rear housing

Damper Ramp Adjustment

After the stove has been in operation for awhile, the damper gasket may compress and allow the damper handle to move from the open to the closed position without the added ramp tension needed to keep the damper held in the closed position.

To adjust the ramp, the stove MUST be allowed to go out and cool down.

- After the stove has cooled off, remove the stove pipe from the stove collar and close the damper.
- Using a flashlight, look into the collar. About midpoint of the damper plate on the backside you will see the adjustment bolt for the ramp tension. (See figure on right.)
- You will need (2) 7/16" wrenches. Use one to hold the bolt still while using the other to loosen the nut.
- Turn the bolt inward (clockwise facing the head) approximately 1/4 turn and retighten the locknut.
- Now open and close the damper to check for proper tension on the damper lever while moving into the closed direction.
- If the tension is incorrect, readjust the bolt.

The Chimney System

Creosote

When wood is burned slowly, it produces tar and other organic vapors, as well as soot, which combine with expelled moisture to form creosote. The creosote vapors condense in the relatively cool chimney flue (associated with a slow burning fire). As a result, creosote accumulates on the flue lining. When ignited, this creosote can result in an extremely hot fire.

The FireDome on the TL300 cuts creosote to almost nothing **when properly burned with dry seasoned wood.**

The chimney should be inspected at least once every two months during the heating season to see if any creosote build-up has occurred. Checking your chimney and chimney connector more frequently, especially while you are getting used to your stove, is recommended. To inspect this system, let the stove cool. Using a flashlight and mirror, check the interior of the chimney connector, and the chimney itself. If a significant layer of creosote or soot has accumulated (1/8" or 3 mm) it should be removed to reduce the risk of a chimney fire.

To clean deposits from the surface of the connector, use a stiff wire brush after dismantling the connector assembly. To clean the chimney, use a specially designed brush sized to fit your particular flue opening, or call an established chimney cleaning service.

At the end of the heating season, perform a thorough examination of your chimney system, and have it repaired if necessary.

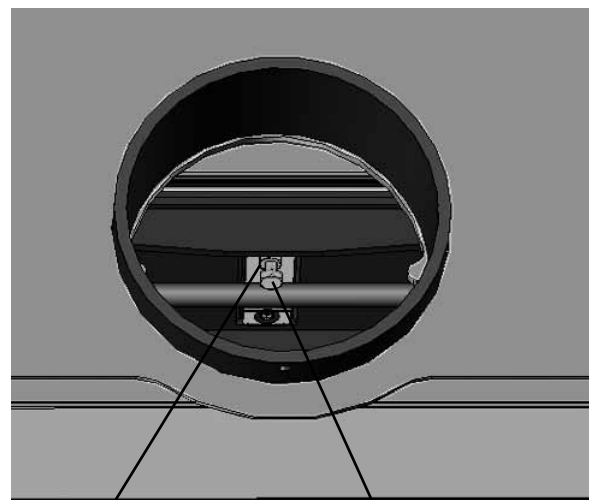

Loosen nut

Turn bolt inward 1/4 turn.

Options

Cooking Grill- #1-00-08121

The TL300 offers a unique stainless steel cooking grill that can easily be taken in and out of the stove for easy cleaning.

Note: Please use heat resistant gloves when handling the cooking grill. Surfaces will be hot enough to cause physical harm.

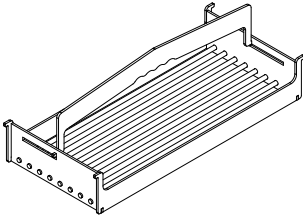

Cozy Screen- #3-40-06960

Your Harman TL300 can be burned like a fireplace with the optional Cozy Screen. The Cozy Screen can be used with either the door in place or with the door removed from the stove. When using the Cozy Screen, the damper bypass must stay in the open position or smoke spillage will occur.

The Cozy Screen can be used from the start of a fire or can be used with an existing one. When starting a fire with the Cozy Screen, smoke spillage may occur until it develops a draft strong enough to pull all smoke back into the flue.

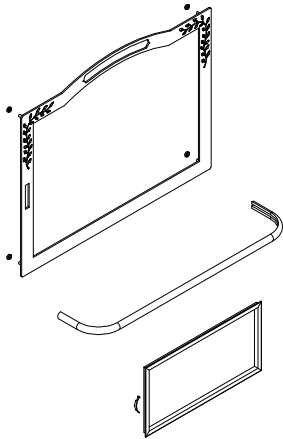

Trim Kit- #1-00-06931-7

The brushed stainless steel trim kit adds elegance to the TL300. The kit includes the door frame, ash lip trim, and tile frame.

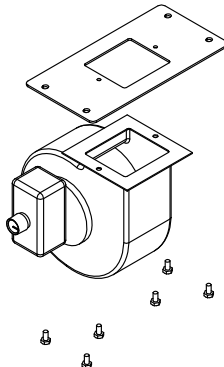

Blower- #1-00-08118

The optional 105 cfm blower helps circulate heated air throughout the home. It installs easily onto the back of the stove, using the included mounting plate.

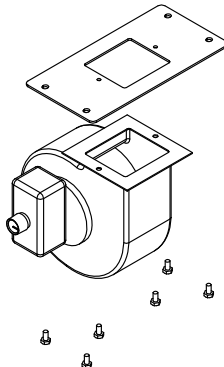

Outside Air (optional)

The TL300 is designed to accommodate the use of outside air introduced directly to the stove. The opening is located at the back of the stove pedestal base. You'll notice there is a rounded hole with the etching of a larger hole. The size needed depends on the length of pipe being used. (see below)

Check with your local building inspector to find out requirements determining if outside air is needed when installing the TL300 in your area. Some signs to watch for that indicate a possible need for outside air: Poor performance of other heaters or of the TL300, including smoke roll-out and odor; the disappearance of the same symptoms when a window is opened near the stove; and condensation on windows in the winter. Modern homes with tight windows and doors, vapor barriers, and particularly with exhaust systems are the most likely to require outside air.

An outside air duct less than 5' (1525 mm) long may be 3" [80mm] in diameter, and be made of masonry tile, 26 gauge (0.019) galvanized steel, or other approved noncombustible material; it should have a 1" (25 mm) clearance to combustibles. Systems longer than 5' (1525 mm), or containing more than two elbows, should have a 4" (100 mm) diameter duct to provide an adequate flow of combustion air. The air duct must terminate outside the dwelling and be screened to keep out debris, birds or animals.

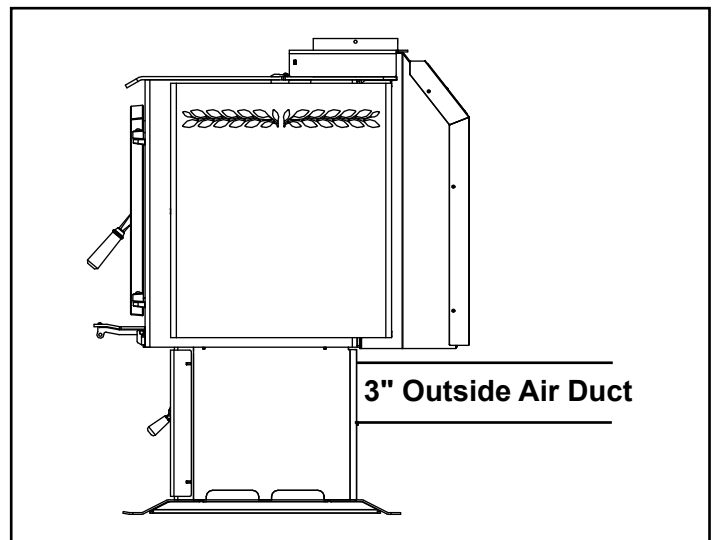

Wood Stove
1-90-06900-1 (Black),

Beginning Manufacturing Date: Aug. 2007
Ending Manufacturing Date: Active

Retired Units

1-90-06900-2 (Charcoal) (Ending Manufacturing Date: June 2011)
1-90-06900-3 (Goldenfire) (Ending Manufacturing Date: June 2011)
1-90-06900-4 (Metallic Blue) (Ending Manufacturing Date: Jan 2010)

1-90-06900-5 (Honey Glo) (Ending Manufacturing Date: June 2009)
1-90-06900-10 (Mojave Red) (Ending Manufacturing Date: Jan 2010)
1-90-06900-12 (Forest Green) (Ending Manufacturing Date: Jan 2010)

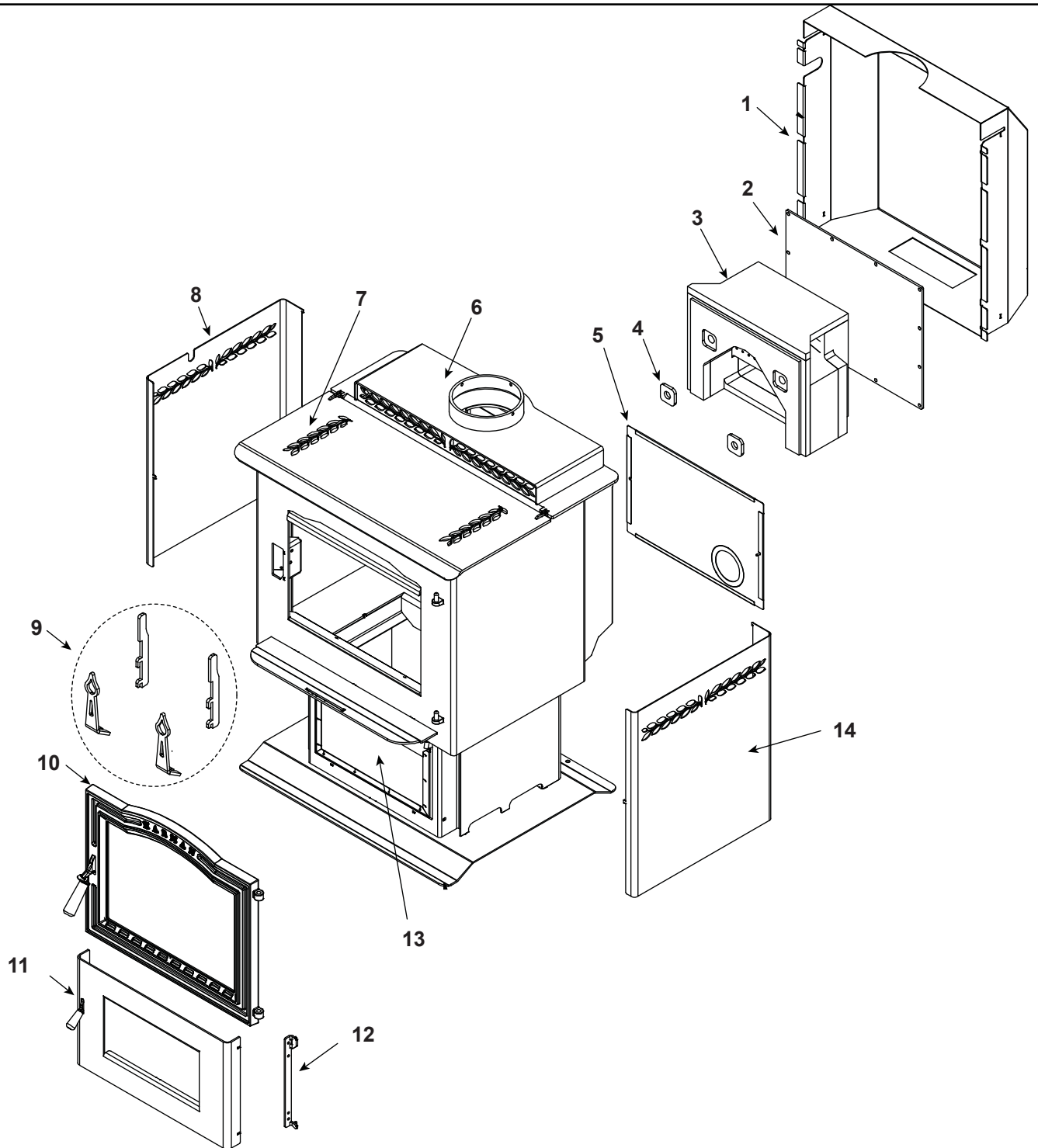

Part number list on following page.

IMPORTANT: THIS IS DATED INFORMATION. When requesting service or replacement parts for your appliance please provide model number and serial number. All parts listed in this manual may be ordered from an authorized dealer.



**Stocked
at Depot**

ITEM	DESCRIPTION	COMMENTS	PART NUMBER	
1	Rear Air Jacket		1-10-06928P	
	1/4-20 x 1/2" Grade 8.2 Zinc SAE Flange Bolt	Pkg of 50	3-30-2001-50	Y
2	Combustion Package Cover		2-00-06922L	
3	Combustion Package		3-40-06999	Y
	Combustion Package Base Gasket	Pkg of 2	3-44-06949-2	Y
	Gasket Package, Side and Top		3-44-06997	
4	Gasket, Brick Air	Pkg of 4	3-44-2500202-4	Y
5	Outside Air Plate		2-00-06943P	
	5/16-18 x 1 1/4" Grade 5 Zinc Plated Hex Cap Screw	Pkg of 50	3-30-1129-50	Y
6	Top Air Grill Assembly		1-10-06946P	
7	Top Load Door Assembly		1-10-06921A	Y
	Dowel Pin, .250 x .375	Pkg of 15	3-30-2019-15	
	Top Load Door Gasket Plate		1-10-40020	Y
	Gasket, Top Load Door		1-00-10050	Y
	Hinge Spacer	Qty 2 req	2-00-40021L	
	Lid Hinge Set, Bottom		1-00-40022	Y
	Nut, Zinc Plated Acron	Pkg of 50	3-30-8014-50	Y
8	Left Side Shield		2-00-06926P	Y
9	Andrion and Andiron Extension Set w/Hardware		2-00-05222-1	Y
	Screw, 5/16-18 x 3/4" Grade 5 Zinc Plated Hex Cap	Pkg of 100	3-30-1125-100	Y
	Washer, 5/16" Zinc Plated USS Flat	Pkg of 100	3-30-0204-100	Y
10	Front Load Door Assembly		1-10-06920A	
	Door Latch		1-00-249119	Y
	Gasket, Glass	15 Ft	1-00-2312	Y
	Gasket, Load Door	30 Ft	1-00-00888	Y
	Glass Clips w/Hardware		2-00-05202-4	Y
	Glass, Load Door	Pkg of 4	3-40-06932	Y
	Mounting Screw for Handle, 1/4"-20 x 2 1/2"	Pkg of 25	3-30-6007-25	Y
	Screw, 10-24 x 3/8", Button Head Cap for Glass clips	Pkg of 100	3-30-3011-100	Y
	Wooden Handle		1-00-00247	Y
11	Ash Door Assembly		1-10-06915A	
	Ash Door Latch		3-00-249149	
	Gasket, Ash door	5 Ft	1-00-10000	Y
	Wooden Knob, Ash Door	Pkg of 3	3-40-08746-3	
12	Bolt on Ash Door Hinge		2-00-06952B	Y
13	Ash Pan		1-10-06938	Y
14	Right Side Shield		2-00-06927P	Y

Additional service part numbers appear on following page.

IMPORTANT: THIS IS DATED INFORMATION. When requesting service or replacement parts for your appliance please provide model number and serial number. All parts listed in this manual may be ordered from an authorized dealer.

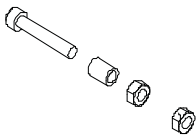
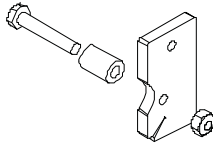
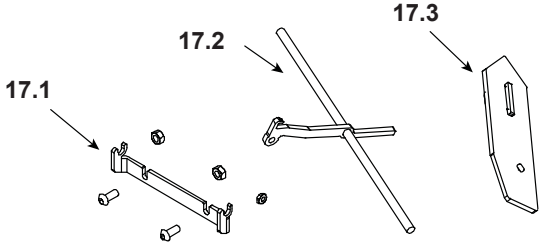
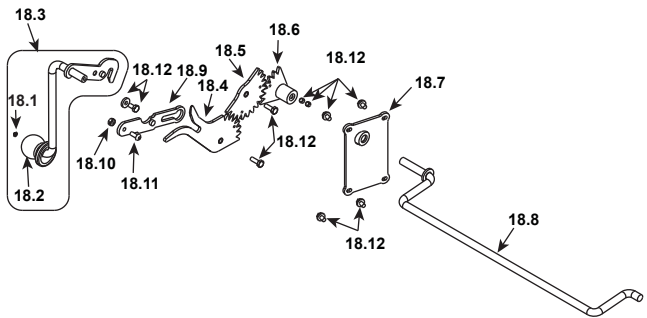

**Stocked
at Depot**

ITEM	DESCRIPTION	COMMENTS	PART NUMBER		
#15 Kit A 		#16 Kit B 			
15	Kit A (Includes Screws, Steel Sleeve Bushing)		1-00-06902		
16	Kit B (Includes Screws, Steel Sleeve Bushing, Latch Adjuster Plate, Reverse Lock Nut).		1-00-06903		
#17 Air Slide Assembly 					
17.1	Rod Bracket		2-00-06963B		
17.2	Air Slide Adjuster		1-10-06964W		
17.3	Air Slide Weldment		1-10-06950W		
#18 Damper Arm Assembly 					
18.1	Push-On Cap Lift Arm		3-31-500015		
18.2	Wooden Knob		3-40-06956	Y	
18.3	Damper Linkage Arm Weldment w/Hardware		1-10-06937W	Y	
18.4	Damper Pivot Gear	Pkg of 2	2-00-06924-2		
18.5	Damper Idler Gear		2-00-06923L		
18.6	Damper Arm Gear Weldment		1-10-06916W	Y	
18.7	Damper Shaft Cover Weldment		1-10-06918W		
18.8	Damper Linkage Weldment		1-10-249146	Y	
18.9	Top Lift Arm weldment		1-10-08127	Y	
18.10	1/4-20 Reversible Lock Nut	Pkg of 100	3-30-8020-100	Y	
18.11	1/4-20 x 5/8 BHSCS	Pkg of 100	3-30-3016-100	Y	
18.12	Hardware Package (Includes Drive Arm Washer, Pusher Block Bushing, Wave Washer, Screws)		1-00-06901	Y	

Additional service part numbers appear on following page.

#19 Firebox Assembly

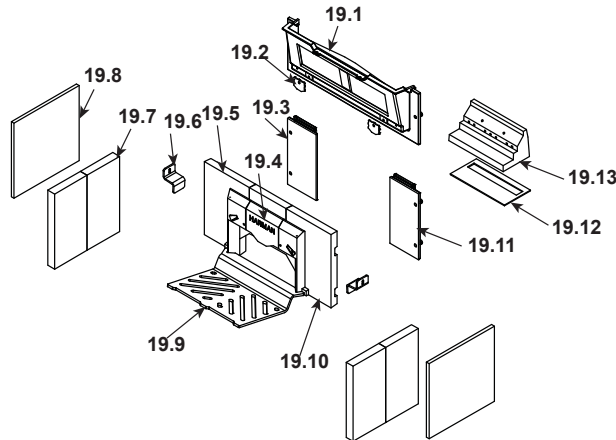

IMPORTANT: THIS IS DATED INFORMATION. When requesting service or replacement parts for your appliance please provide model number and serial number. All parts listed in this manual may be ordered from an authorized dealer.



**Stocked
at Depot**

ITEM	DESCRIPTION	COMMENTS	PART NUMBER	
19.1	Damper Frame Assembly (Includes Damper)		1-10-249106	Y
	Adjuster w/Hardware	Pre 008323034	1-00-249142	Y
		Post 008323034	1-00-250153	
	Damper w/Adjuster		1-10-249107	
	Damoer Shaft Retainers and Hardware	1 Set	1-00-249145	Y
	Gasket, 3/8" Round White for Damper Frame & Plate	30 Ft	1-00-00888	Y
19.2	Rear Brick Clip	Pkg of 2	1-00-249153	Y
19.3	Left Inside Plate Assembly w/Gasket		1-10-249117A	Y
19.4	Logo Brick		3-40-00101	Y
19.5	Inlet Brick Left		3-40-00103	Y
19.6	Side Brick Bracket	Pkg of 2	1-00-06945	Y
19.7	Fire Brick 6" x 12" (Qty 4 req)	Pre #551	4-40-86125	Y
		Post #551	3-40-86125	Y
19.8	Brick Insulation	Qty 2 req	3-40-06944	Y
19.9	Grate		2-00-06925B	Y
19.10	Inlet Brick Right		3-40-00104	Y
19.11	Right Inside Plate Assembly w/Gasket		1-10-249118A	Y
19.12	Shoe Brick Gasket		3-44-06951	Y
19.13	Shoe Brick		3-40-00100	Y
	Hardware Package (Includes Screws, Centerlock Nuts)		1-00-06900	Y
	Blower Option		1-00-08118	
	105 CFM Blower w/VSC		3-21-50757	Y
	Blower Mounting Plate		2-00-05218P	
	Hex Cap Screw for Blower Mounting Plate	Pkg of 50	3-30-1108-50	Y
	Air Grill Trim, Brushed Stainless		3-43-06948-7	
	Ashlip Trim, brushed Stainless		3-43-4722386-7	
	Door Trim, Brushed Stainless		3-43-06931-7	
	Tile Frame, Brushed Stainless		3-43-06729-7	
	Spring clip for Tile Frame	Pkg of 20	3-31-232547-20	

This page intentionally left blank.

Hearth & Home Technologies Inc. LIMITED LIFETIME WARRANTY

Hearth & Home Technologies Inc., on behalf of its hearth brands ("HHT"), extends the following warranty for HHT gas, wood, pellet, coal and electric hearth appliances that are purchased from an HHT authorized dealer.

WARRANTY COVERAGE:

HHT warrants to the original owner of the HHT appliance at the site of installation, and to any transferee taking ownership of the appliance at the site of installation within two years following the date of original purchase, that the HHT appliance will be free from defects in materials and workmanship at the time of manufacture. After installation, if covered components manufactured by HHT are found to be defective in materials or workmanship during the applicable warranty period, HHT will, at its option, repair or replace the covered components. HHT, at its own discretion, may fully discharge all of its obligations under such warranties by replacing the product itself or refunding the verified purchase price of the product itself. The maximum amount recoverable under this warranty is limited to the purchase price of the product. This warranty is subject to conditions, exclusions and limitations as described below.

WARRANTY PERIOD:

Warranty coverage begins on the date of original purchase. In the case of new home construction, warranty coverage begins on the date of first occupancy of the dwelling or six months after the sale of the product by an independent, authorized HHT dealer/ distributor, whichever occurs earlier. The warranty shall commence no later than 24 months following the date of product shipment from HHT, regardless of the installation or occupancy date. The warranty period for parts and labor for covered components is produced in the following table.

The term "Limited Lifetime" in the table below is defined as: 20 years from the beginning date of warranty coverage for gas appliances, and 10 years from the beginning date of warranty coverage for wood, pellet, and coal appliances. These time periods reflect the minimum expected useful lives of the designated components under normal operating conditions.

Warranty Period		HHT Manufactured Appliances and Venting							Components Covered
Parts	Labor	Gas	Wood	Pellet	EPA Wood	Coal	Electric	Venting	
1 Year		X	X	X	X	X	X	X	All parts and material except as covered by Conditions, Exclusions, and Limitations listed
2 years				X	X	X			Igniters, electronic components, and glass
		X	X	X	X	X			Factory-installed blowers
				X					Molded refractory panels
3 years				X					Firepots and burnpots
5 years	1 year			X	X				Castings and baffles
7 years	3 years		X	X	X				Manifold tubes, HHT chimney and termination
10 years	1 year	X							Burners, logs and refractory
Limited Lifetime	3 years	X	X	X	X	X			Firebox and heat exchanger
90 Days		X	X	X	X	X	X	X	All replacement parts beyond warranty period

See conditions, exclusions, and limitations on next page.

WARRANTY CONDITIONS:

- This warranty only covers HHT appliances that are purchased through an HHT authorized dealer or distributor. A list of HHT authorized dealers is available on the HHT branded websites.
- This warranty is only valid while the HHT appliance remains at the site of original installation.
- Contact your installing dealer for warranty service. If the installing dealer is unable to provide necessary parts, contact the nearest HHT authorized dealer or supplier. Additional service fees may apply if you are seeking warranty service from a dealer other than the dealer from whom you originally purchased the product.
- Check with your dealer in advance for any costs to you when arranging a warranty call. Travel and shipping charges for parts are not covered by this warranty.

WARRANTY EXCLUSIONS:

This warranty does not cover the following:

- Changes in surface finishes as a result of normal use. As a heating appliance, some changes in color of interior and exterior surface finishes may occur. This is not a flaw and is not covered under warranty.
- Damage to printed, plated, or enameled surfaces caused by fingerprints, accidents, misuse, scratches, melted items, or other external sources and residues left on the plated surfaces from the use of abrasive cleaners or polishes.
- Repair or replacement of parts that are subject to normal wear and tear during the warranty period. These parts include: paint, wood, pellet and coal gaskets, firebricks, grates, flame guides, light bulbs, batteries and the discoloration of glass.
- Minor expansion, contraction, or movement of certain parts causing noise. These conditions are normal and complaints related to this noise are not covered by this warranty.
- Damages resulting from: (1) failure to install, operate, or maintain the appliance in accordance with the installation instructions, operating instructions, and listing agent identification label furnished with the appliance; (2) failure to install the appliance in accordance with local building codes; (3) shipping or improper handling; (4) improper operation, abuse, misuse, continued operation with damaged, corroded or failed components, accident, or improperly/incorrectly performed repairs; (5) environmental conditions, inadequate ventilation, negative pressure, or drafting caused by tightly sealed constructions, insufficient make-up air supply, or handling devices such as exhaust fans or forced air furnaces or other such causes; (6) use of fuels other than those specified in the operating instructions; (7) installation or use of components not supplied with the appliance or any other components not expressly authorized and approved by HHT; (8) modification of the appliance not expressly authorized and approved by HHT in writing; and/or (9) interruptions or fluctuations of electrical power supply to the appliance.
- Non-HHT venting components, hearth components or other accessories used in conjunction with the appliance.
- Any part of a pre-existing fireplace system in which an insert or a decorative gas appliance is installed.
- HHT's obligation under this warranty does not extend to the appliance's capability to heat the desired space. Information is provided to assist the consumer and the dealer in selecting the proper appliance for the application. Consideration must be given to appliance location and configuration, environmental conditions, insulation and air tightness of the structure.

This warranty is void if:

- The appliance has been over-fired or operated in atmospheres contaminated by chlorine, fluorine, or other damaging chemicals. Over-firing can be identified by, but not limited to, warped plates or tubes, rust colored cast iron, bubbling, cracking and discoloration of steel or enamel finishes.
- The appliance is subjected to prolonged periods of dampness or condensation.
- There is any damage to the appliance or other components due to water or weather damage which is the result of, but not limited to, improper chimney or venting installation.

LIMITATIONS OF LIABILITY:

- The owner's exclusive remedy and HHT's sole obligation under this warranty, under any other warranty, express or implied, or in contract, tort or otherwise, shall be limited to replacement, repair, or refund, as specified above. In no event will HHT be liable for any incidental or consequential damages caused by defects in the appliance. Some states do not allow exclusions or limitation of incidental or consequential damages, so these limitations may not apply to you. This warranty gives you specific rights; you may also have other rights, which vary from state to state. EXCEPT TO THE EXTENT PROVIDED BY LAW, HHT MAKES NO EXPRESS WARRANTIES OTHER THAN THE WARRANTY SPECIFIED HEREIN. THE DURATION OF ANY IMPLIED WARRANTY IS LIMITED TO DURATION OF THE EXPRESSED WARRANTY SPECIFIED ABOVE.

At Harman, we build each product to a standard, not a price. This powerful heating appliance boasts uncompromising attention to detail and helps preserve our planet by using environmentally responsible fuels.



(Signature of Boxer)

Your premium quality hearth product designed and assembled by the experienced and skilled members at Harman in Halifax, PA, USA.

HARMAN[™]

BUILT TO A STANDARD, NOT A PRICE

Proudly Printed On 100% Recycled Paper

