

CENTRAL PNEUMATIC®

CONTRACTOR SERIES

FLOOR STAPLER WITH HAMMER

Model 93197

**ASSEMBLY and OPERATING
INSTRUCTIONS**



Distributed Exclusively by



**HARBOR FREIGHT
TOOLS**



3491 Mission Oaks Blvd., Camarillo, CA 93011
Visit our Web site at <http://www.harborfreight.com>

Copyright© 2005 by Harbor Freight Tools®. All rights reserved. No portion of this manual or any artwork contained herein may be reproduced in any shape or form without the express written consent of Harbor Freight Tools.

For technical questions and replacement parts, please call 1-800-444-3353

Specifications

Air Inlet	1/4" - 18 NPT
Recommended Air Pressure	70-90 PSI
Maximum Air Pressure	100 PSI
Dimensions	22-1/2" x 17-1/2" x 3-1/8"
Weight	21.85 Lbs.
Magazine Capacity	80 Pcs. / Top Loaded
Air Consumption	5.0 CFM @ 80 PSI
Fastener Size Range	3/4" to 2" Long x 15 Gauge

Note: SKU 90429 - 2", 15 Gauge Staples are available from Harbor Freight Tools.

Note: This Floor Stapler is designed for use on wood floors.

Save This Manual

You will need the manual for the safety warnings and precautions, assembly instructions, operating and maintenance procedures, parts list and diagram. Keep your invoice with this manual. Write the invoice number on the inside of the front cover. Keep the manual and invoice in a safe and dry place for future reference.

Safety Warnings and Precautions

WARNING: When using tool, basic safety precautions should always be followed to reduce the risk of personal injury and damage to equipment.

Read all instructions before using this tool!

- 1. THIS TOOL DOES NOT USE A SAFETY MECHANISM; extreme caution must be used whenever this tool is connected to an air supply.** If the tool is dropped or if the Hammer Face (10) is accidentally struck, then the tool will fire a staple, potentially causing **SEVERE PERSONAL INJURY**.
- 2. Keep work area clean.** Cluttered areas invite injuries.
- 3. Observe work area conditions.** Do not use machines or power tools in damp or wet locations. Don't expose to rain. Keep work area well lighted. Do not use electrically powered tools in the presence of flammable gases or liquids.
- 4. Keep children away.** Children must never be allowed in the work area. Do not let them handle machines, tools, extension cords, or air hoses.
- 5. Store idle equipment.** When not in use, tools must be stored in a dry location to inhibit rust. Always lock up tools and keep out of reach of children.
- 6. Use the right tool for the job.** Do not attempt to force a small tool or attachment to do the work of a larger industrial tool. There are certain applications for which this tool was designed. It will do the job better and more safely at the rate for which it was intended. Do not modify this tool and do not use this tool for a purpose for which it was not intended.

7. **Dress properly.** Do not wear loose clothing or jewelry as they can be caught in moving parts. Protective, electrically nonconductive clothes and nonskid footwear are recommended when working. Wear restrictive hair covering to contain long hair.
8. **Use eye and ear protection.** Always wear ANSI approved impact safety goggles. Wear a full face shield if you are producing metal filings or wood chips. Wear an ANSI approved dust mask or respirator when working around metal, wood, and chemical dusts and mists.
9. **Do not overreach.** Keep proper footing and balance at all times. Do not reach over or across running machines or air hoses.
10. **Maintain tools with care.** Keep tools clean for better and safer performance. Follow instructions for lubricating and changing accessories. Inspect tool cords and air hoses periodically and, if damaged, have them repaired by an authorized technician. The handles must be kept clean, dry, and free from oil and grease at all times.
11. **Disconnect air supply.** Disconnect air hose when not in use.
12. **Remove adjusting keys and wrenches.** Check that keys and adjusting wrenches are removed from the tool or machine work surface before plugging it in.
13. **Avoid unintentional starting.** Do not carry any tool with pressure applied to the **Hammer Face (10)**, whether it is plugged in or not.
14. **Stay alert.** Watch what you are doing, use common sense. Do not operate any tool when you are tired.
15. **Check for damaged parts.** Before using any tool, any part that appears damaged should be carefully checked to determine that it will operate properly and perform its intended function. Check for alignment and binding of moving parts; any broken parts or mounting fixtures; and any other condition that may affect proper operation. Any part that is damaged should be properly repaired or replaced by a qualified technician. Do not use the tool if any switch does not turn On and Off properly.
16. **Guard against electric shock.** Prevent body contact with grounded surfaces such as pipes, radiators, ranges, and refrigerator enclosures.
17. **Replacement parts and accessories.** When servicing, use only identical replacement parts. Use of any other parts will void the warranty. Only use accessories intended for use with this tool. Approved accessories are available from Harbor Freight Tools.
18. **Do not operate tool if under the influence of alcohol or drugs.** Read warning labels if taking prescription medicine to determine if your judgement or reflexes are impaired while taking drugs. If there is any doubt, do not operate the tool.
19. **Use proper size and type extension cord.** If an extension cord is required for the air compressor, it must be of the proper size and type to supply the correct current to the tool without heating up. Otherwise, the extension cord could melt and catch fire, or cause electrical damage to the tool. Check your compressor's manual for the appropriate size cord.

Note: Performance of the compressor (if powered by line voltage) may vary depending on variations in local line voltage. Extension cord usage may also affect tool performance.

20. **Maintenance.** For your safety, maintenance should be performed regularly by a qualified technician.
21. **Compressed air only.** Never use combustible gases as a power source.

Warning: The warnings, cautions, and instructions discussed in this instruction manual cannot cover all possible conditions and situations that may occur. It must be understood by the operator that common sense and caution are factors which cannot be built into this product, but must be supplied by the operator.

WARNING: Some dust created by power sanding, sawing, grinding, drilling, and other construction activities, contain chemicals known [to the State of California] to cause cancer, birth defects or other reproductive harm. Some examples of these chemicals are:

- Lead from lead-based paints
- Crystalline silica from bricks and cement or other masonry products
- Arsenic and chromium from chemically treated lumber

Your risk from these exposures varies, depending on how often you do this type of work. To reduce your exposure to these chemicals: work in a well ventilated area, and work with approved safety equipment, such as those dust masks that are specially designed to filter out microscopic particles.

(California Health & Safety Code § 25249.5, *et seq.*)

Unpacking

When unpacking, check to make sure the parts listed on page 8 are included. If any parts are missing or broken, please call Harbor Freight Tools at the number on the cover of this manual as soon as possible

Operation

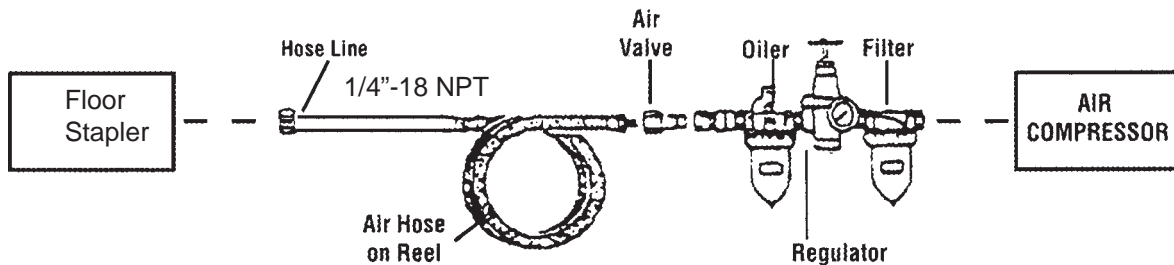

Recommended Air Line Components

For best service you should incorporate an oiler, regulator, and inline filter, as shown in the diagram above. Hoses, couplers, oilers, regulators, and filters are all available at Harbor Freight Tools.

1. You will need to prepare a 1/4" air connector (sold separately) to connect to the air inlet on the Floor Stapler. First, wrap the 1/4" air connector (not included) with pipe thread seal tape before threading it into the **Air Inlet (47)**. Connect the 3/8" ID Air Source Hose to the **Air Inlet (47)**.

Note: If you are not using an automatic oiler system, before operation, add a few drops of Pneumatic Tool Oil to the airline connection. Add a few drops more after each hour of continual use.

2. Set the air pressure on your compressor to between 70-90 PSI. Do not exceed the maximum air pressure of 100 PSI.
3. Check the air connection for leaks. Disconnect from the air source.

Operation (continued)

Assembly - Attaching the **Arm (48)** is the only assembly required. See **FIGURE 1** and the Assembly Drawing on page 8.

The two **Clamp Screws (44)** fit in the recessed gaps on the lower part of the **Arm (48)**. As shown below, hold the **Clamp Screws (44)** in place around the **Body (18)** and add a **Washer (45)** and a **Nut (46)** to the threaded ends of the **Clamp Screws (44)**. Tighten them securely.

FIGURE 1

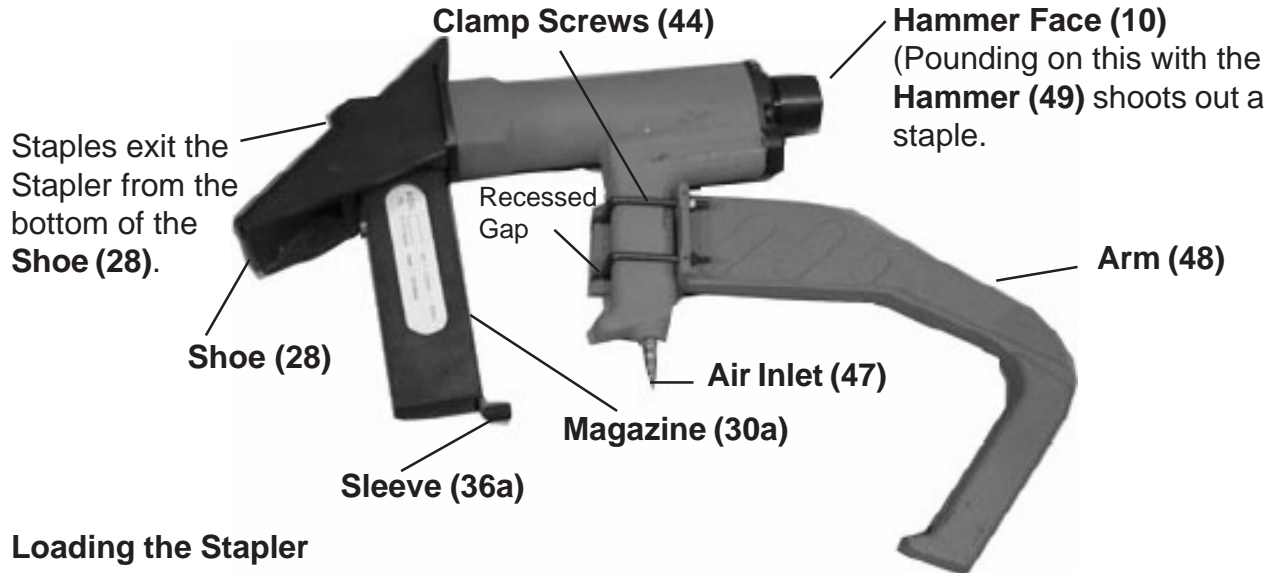

Loading the Stapler

Warning! Disconnect the Stapler from the air compressor whenever loading or servicing. After disconnecting the Stapler from the air compressor, there could still be enough air pressure to fire the Stapler. After the air compressor hose is disconnected, always fire the Stapler repeatedly to make sure all of the air is expended. See page 6 under “Using the Stapler” for firing instructions.

1. Grip the **Sleeve (36a)** and pull out the **Magazine Cover (33a)**. Insert the staples inside the **Magazine (30a)**.

Note: Only use the size staples listed on the Specifications Chart on page 2.

2. **Use caution, the Magazine Cover (33a) will try to snap closed with force when the Pin (38) is pressed.** While holding the **Sleeve (36a)** firmly, use a small screwdriver to press in the Locking Pin (38) along the edge of the Magazine Cover. See **FIGURE 2**.

FIGURE 2

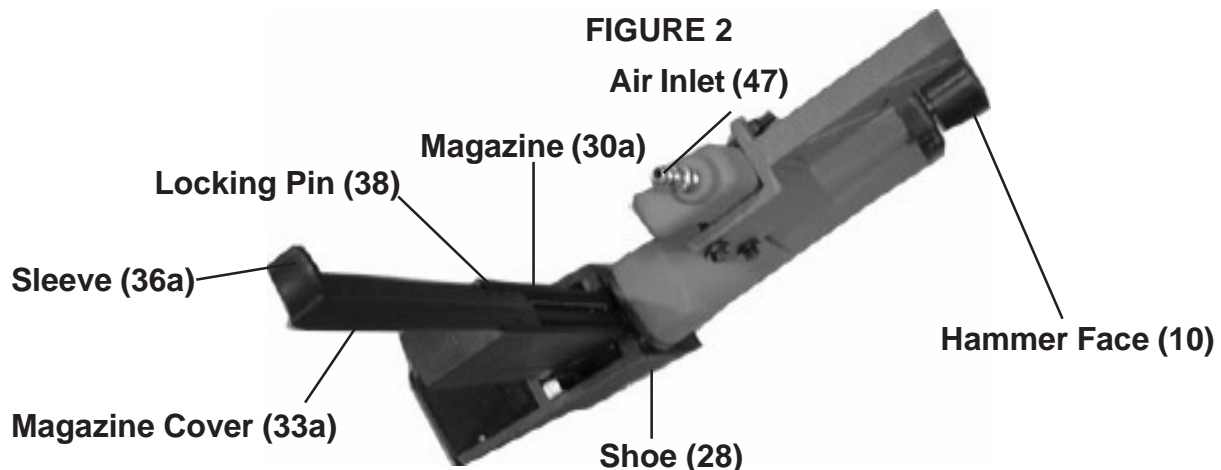

Operation (continued)

Using the Floor Stapler

THIS TOOL DOES NOT USE A SAFETY MECHANISM; extreme caution must be used whenever this tool is connected to an air supply. If the tool is dropped or if the Hammer Face (10) is accidentally struck, then the tool will fire a staple, potentially causing **SEVERE PERSONAL INJURY**.

1. Connect the Floor Stapler to the air hose and turn on the air compressor.

Note: Before using on a floor, test the unit on a scrap piece of wood. Adjust the driving depth by providing more or less air pressure. Never exceed 100 PSI.

Warning! Keep your feet clear of the Stapler. Refer to **FIGURES 1 and 3**.

2. Hold the **Arm (48)** securely with one hand and grip the **Hammer (49)** with the other hand.
3. Make sure the **Shoe (28)** is over the staple target position. Press down hard so that the **Shoe (28)** is firmly contacting the floor, and then strike the **Hammer Face (10)** with the **Hammer (49)** to drive out a staple. Lift the tool off of the floor.
4. Repeat the process until you are finished. Then, disconnect the Floor Stapler from the air source.

Warning! After disconnecting the Stapler from the air compressor, there could still be enough air pressure to fire the Stapler. After the air compressor hose is disconnected, always fire the Stapler repeatedly to make sure all of the air is expended

FIGURE 3

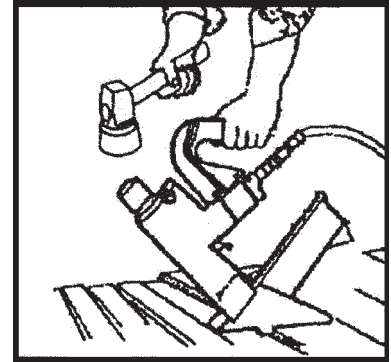

Troubleshooting

Note: Have the following problems repaired by a qualified service technician.

PROBLEM	CAUSE	SOLUTION
Air leaking in nose	<ol style="list-style-type: none"> 1. Loose Nose Screws 2. Bumper is cracked/worn 	<ol style="list-style-type: none"> 1. Tighten and recheck 2. Replace Bumper
Lack of Power, slow to cycle.	<ol style="list-style-type: none"> 1. Tool is too dry 2. Air Pressure is too low 3. Exhaust blocked 	<ol style="list-style-type: none"> 1. Lubricate 2. Check air supply equipment 3. Clean exhaust channel
Intermittent feeding or no fastener coming out	<ol style="list-style-type: none"> 1. Damaged pusher spring 2. Wrong size staple 3. Dirty magazine or wear-plate 	<ol style="list-style-type: none"> 1. Replace Spring 2. Use correct size 3. Clean magazine and nose
Jammed Staple	<ol style="list-style-type: none"> 1. Driver channel worn 2. Driver is broken/worn 3. Bent staples 	<ol style="list-style-type: none"> 1. Replace wear plate 2. Replace driver 3. Use straight staples

Anytime any maintenance or repairs are done (including clearing jams), FIRST:

1. Disconnect the Stapler from the air hose.
2. Empty Magazine (30a) completely.
3. Attempt to fire the Stapler into a piece of scrap wood to ensure that it is disconnected and is incapable of firing any staples.
4. **Always leave Magazine Cover (33a) open during maintenance. The Magazine is spring-loaded and may cause parts or a staple to fly out of the Stapler.**

Clearing Jams

1. Disconnect tool from air hose, empty Magazine (30a) of staples, release any built-up air pressure, and leave the magazine open, as explained above.
2. While doing this step and the next, hold the Stapler pointed away from you and any other people or fragile objects. Remove all four Screws (11) and Washers (23a) on the Driver Guide (22a).
3. Carefully lift the Driver Guide (22a) off and remove the jammed staple. Pliers may be necessary to remove a stuck staple.
5. Inspect the driver on the end of the Piston Assembly (9) for bends or breakage. If it is damaged, do not use the tool until it is repaired by a qualified technician.
6. Lightly oil the driver and replace the Driver Guide (22a). Replace and securely tighten all of the Screws (11) and Washers (23a).
7. Reload the Stapler.
8. Reconnect the Stapler to the air hose.
9. Press the tip of the Stapler against an appropriate piece of scrap wood.
10. Test fire the Stapler several times, checking for proper operation.
11. Disconnect the Stapler, remove the staples, and store the Stapler in a location out of children's reach.

Maintenance

1. Periodically lubricate all moving parts and pivots with a light oil.
2. Wipe down the Floor Stapler with a damp cloth. Do not use harsh detergents or solvents.
3. Check that the **Shoe (28)** and the **Hammer Face (10)** is clear of any dirt or debris.

PLEASE READ THE FOLLOWING CAREFULLY

THE MANUFACTURER AND/OR DISTRIBUTOR HAS PROVIDED THE PARTS DIAGRAM IN THIS MANUAL AS A REFERENCE TOOL ONLY. NEITHER THE MANUFACTURER NOR DISTRIBUTOR MAKES ANY REPRESENTATION OR WARRANTY OF ANY KIND TO THE BUYER THAT HE OR SHE IS QUALIFIED TO MAKE ANY REPAIRS TO THE PRODUCT OR THAT HE OR SHE IS QUALIFIED TO REPLACE ANY PARTS OF THE PRODUCT. IN FACT, THE MANUFACTURER AND/OR DISTRIBUTOR EXPRESSLY STATES THAT ALL REPAIRS AND PARTS REPLACEMENTS SHOULD BE UNDERTAKEN BY CERTIFIED AND LICENSED TECHNICIANS AND NOT BY THE BUYER. THE BUYER ASSUMES ALL RISK AND LIABILITY ARISING OUT OF HIS OR HER REPAIRS TO THE ORIGINAL PRODUCT OR REPLACEMENT PARTS THERETO, OR ARISING OUT OF HIS OR HER INSTALLATION OF REPLACEMENT PARTS THERETO.

Parts List

Part	Description	Part	Description
1	Cylinder Bushing	26	Screw
2	Plunger	27	Spacer for 25/32" Flooring
3	O-ring	27a	Spacer for 1/2" Flooring
4	O-ring	28	Shoe
5	Poppet	29a	Pin
6	O-ring	30a	Magazine
7	O-ring	31a	Magazine Cap
8	O-ring	32a	Screw
9	Piston Assy.	33a	Magazine Cover
10	Hammer Face	34	Pin
11	Screw	35	Pin
12	Cylinder Cap	36a	Sleeve
13	O-ring	37	Detent Spring
14	Screw	38	Cover Latch Pin
15	Washer	40	Tension Spring
16	Poppet Actuator	41	Pusher
17	Gasket	42	Bushing
18	Body	43	Roller
19	Bumper	44	Clamp Screw
20a	Nose	45	Washer
21a	Screw	46	Nut
22a	Blade Guide	47	Air Inlet
23a	Washer	48	Arm
24	Washer	49	Hammer
25	Screw		

NOTE: #27a - Spacer for 1/2" Flooring (Included but not installed)

NOTE: Some parts are listed and shown for illustration purposes only and are not available individually as replacement parts.

Assembly Diagram

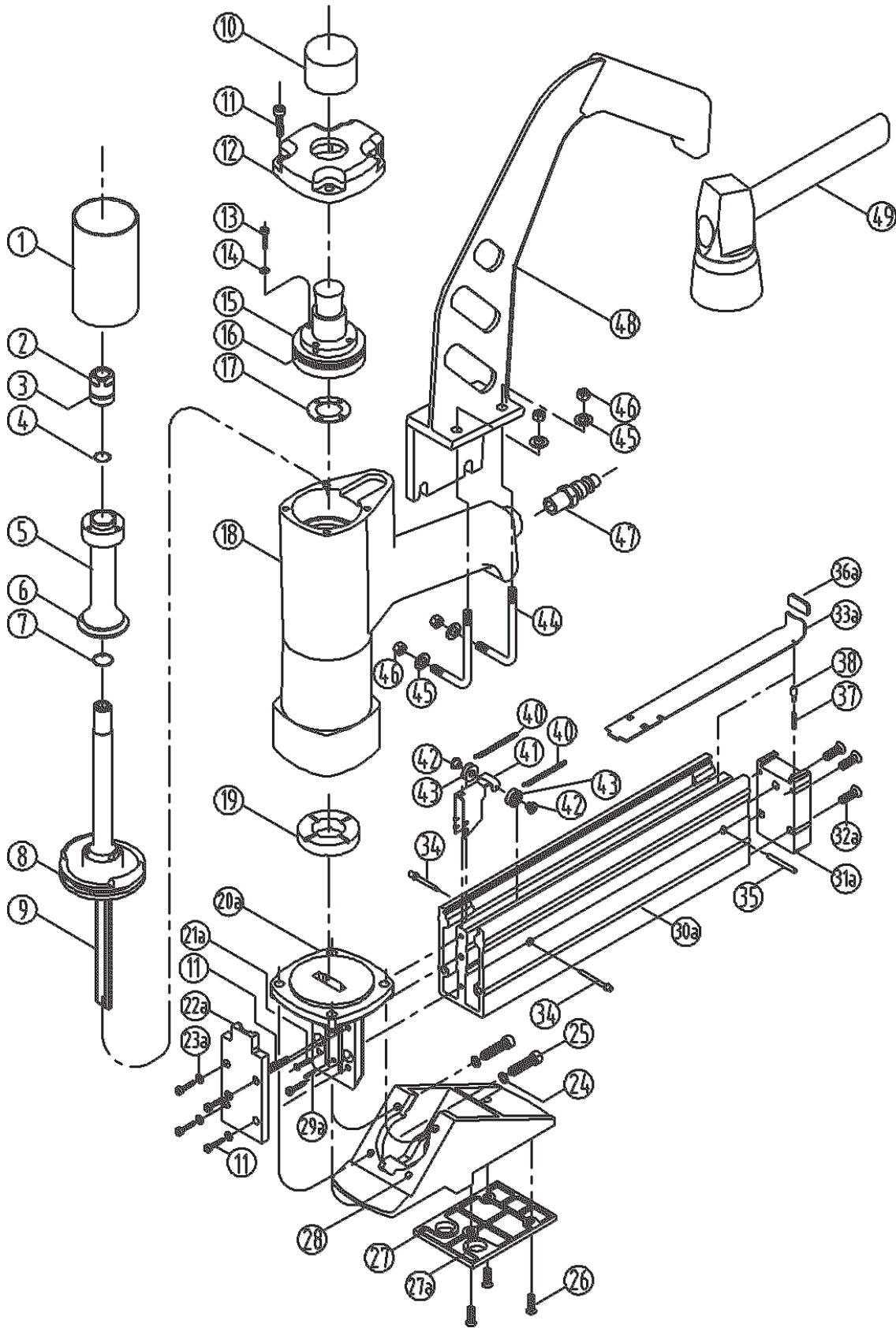

#27 - Installed: (Spacer for 25/32" Flooring)

#27a - Spacer is included with tool, not installed (Spacer for 1/2" Flooring)