

## LIMITED WARRANTY

To the consumer, Guardian Technologies LLC warrants this product to be free of defects in materials or workmanship commencing upon the date of the original purchase. Save your original sales receipt to validate start of warranty period.

If this product should become defective within the warranty period, we will repair or replace any defective parts free of charge. The complete machine must be delivered pre-paid to any authorized Guardian Technologies LLC warranty service center. Please include complete information on the problem, day of purchase, copy of original sales receipt and your name, address and telephone number. If you are not near a warranty station, call the factory for assistance in the US and Canada at 1-866-603-5900. Use only genuine Guardian Technologies replacement parts.

The warranty does not include unusual wear, damage resulting from accident, or unreasonable use of the product. This warranty does not cover unauthorized repairs. This warranty gives you specific legal rights and you may also have other rights (other rights may vary from state to state in the U.S.A).

We consider the registration process important to ensuring superior service to our customers, however submitting this card to Guardian Technologies LLC is optional and does not affect your rights to utilize this warranty according to the conditions stated above. If you have any questions or comments about our product call toll free at 1-866-603-5900 or send comments to: Attn: Customer Service, Guardian Technologies LLC, 7700 St Clair Avenue · Mentor, OH 44060. Warranty registration is also available online at [www.guardiantechnologies.com](http://www.guardiantechnologies.com)

### Guardian Technologies LLC

7700 St Clair Avenue · Mentor, OH 44060  
1-866-603-5900 · [www.guardiantechnologies.com](http://www.guardiantechnologies.com)

©2007 Guardian Technologies LLC



# Pure Guardian™ Ultrasonic Humidifier

## USE & CARE INSTRUCTIONS

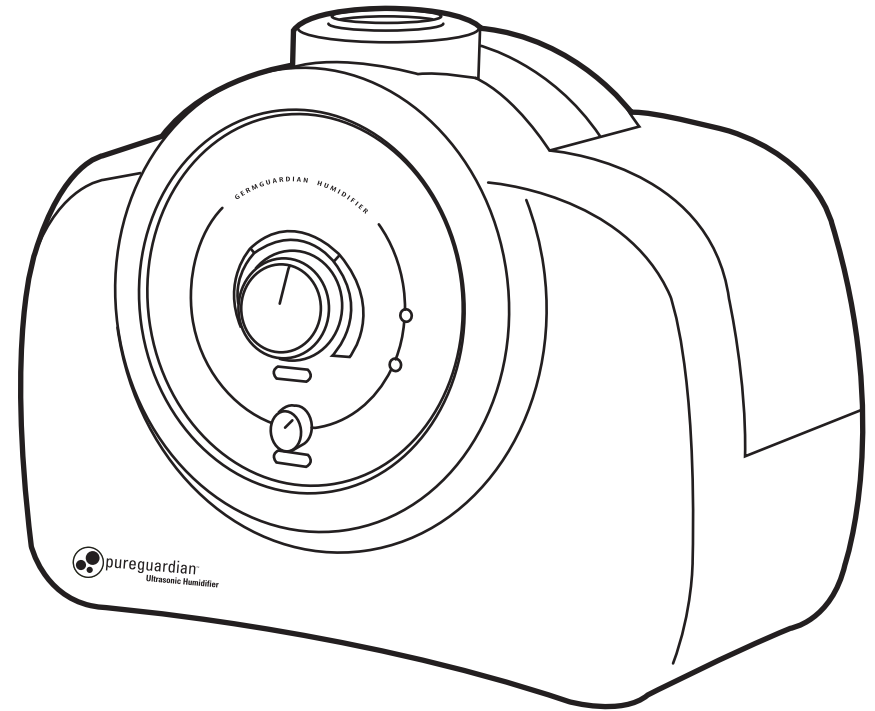

**MODEL NO. R2000**  
**30 Day Limited Warranty**  
**[www.guardiantechnologies.com](http://www.guardiantechnologies.com)**  
**1-866-603-5900**

REV0411

Date Purchased  
month \_\_\_\_\_  
year \_\_\_\_\_

**READ AND SAVE THIS MANUAL**  
**PRODUCT SPECIFICATIONS AND PARTS**

**SPECIFICATIONS**

Model Number: R2000  
Humidifying Mode: Combination  
Power Supply: AC120V, 60Hz  
Power Consumption: 140W (40W at cold humidification)  
Maximum humidity capacity: About 350cc/Hr. (at highest setting and warm humidification)  
Tank Capacity: 1.4 Gallons  
Successive Humidity Hours: Up to approximately 72 hours depending on environmental conditions.  
Dimensions: Width-14.5 inches; Length-9 inches; Height-12 inches  
Weight: 8.8 Pounds (not including packaging)

**PARTS**

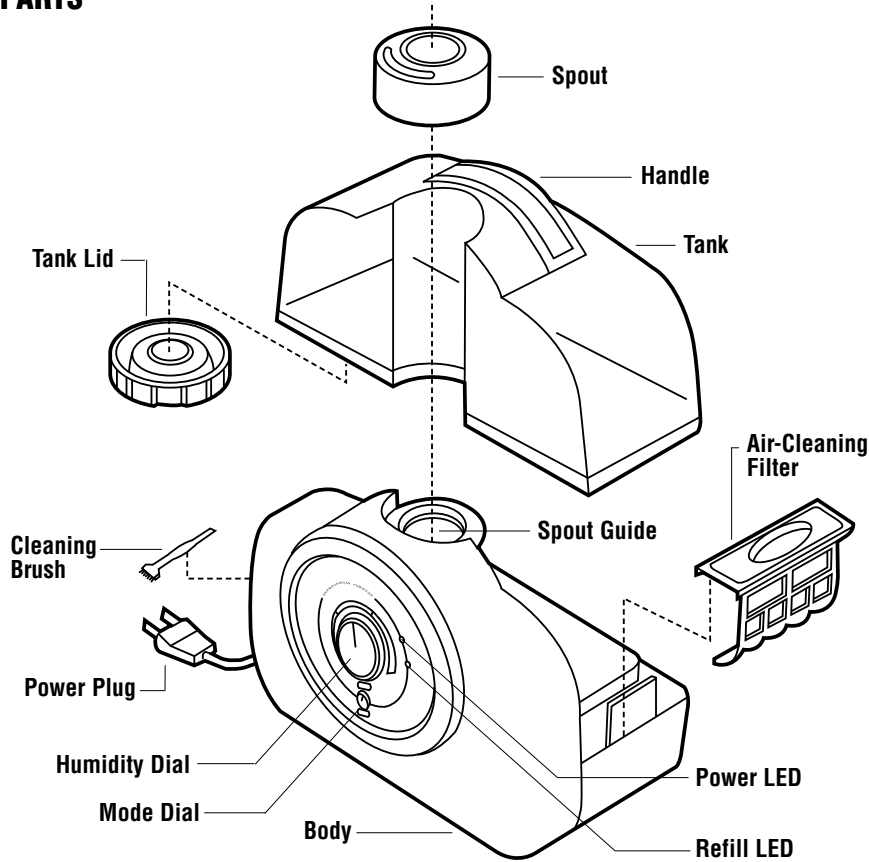

**FUNCTIONS AND FEATURES**

**Warm or Cold Humidification Selection**

Select humidifying temperature based on need. Warm humidity will use more power but will humidify your room quicker.

**Water Shortage Indicator**

When the unit is low on water the Refill LED on the front panel will light up, and the unit will shut off. Simply add more water to continue use.

**Humidity Adjustment**

The humidity volume may be adjusted based on need by using the adjustment knob on the front panel.

**Silver Clean Technology**

Small silver particles have been embedded into the water tank to help fight the growth of mold and mildew on the surface of the water tank.

## WARNINGS



This product should be used only in accordance with the specifications outlined in this manual. Usage other than what has been specified here may result in serious injury.

- Disassembly, repair or remodeling by an unauthorized person may result in serious harm.
- Do not use if plug is damaged or loose.
- Keep this product out of the reach of children and pets.
- Be careful not to put water in the humidity spout.
- Before filling or cleaning the unit, make sure it is unplugged.
- Once the humidifier has been turned on, do not move it.
- Do not remove the water tank from the unit while it is on.
- Do not handle the plug with wet hands.
- Do not excessively bend, twist or pull the power cord.
- Avoid placing this product where the humidity spout is pointed directly at an object.
- Do not directly inhale the humidity spout.
- Do not place this product on a sloped or unstable surface.
- When not in use, unplug the unit.
- Do not fill the water tank with hot or boiling water.
- Do not use this product in direct sunlight, or near a gas stove or heater.
- If the water tank becomes cracked or damaged, do not use.
- Do not keep this product running for an extended period of time.
- Do not clean the unit or water tank with detergents or chemicals of any kind.
- Do not use this product near any other electronic device.
- Do not cover the humidity opening at any time during use.
- Do not use this product near a sink.
- Do not drink water from tank.
- Do not place this product on an absorbent surface.

Failure to comply with the warnings listed above may result in electric shock or serious injury.

## DIRECTIONS FOR USE

Make sure the unit is unplugged.

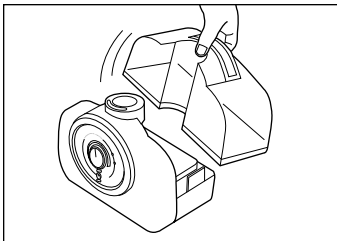

1. Separate the tank from the body of the unit.

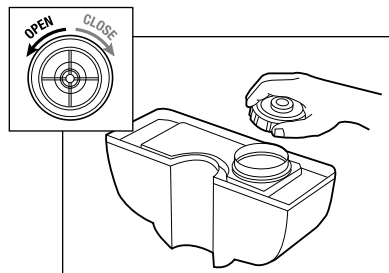

2. Open the tank lid, turning it to the left.

## DIRECTIONS FOR USE (cont.)

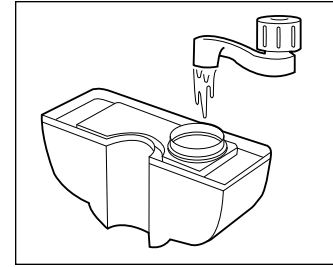

3. Pour cool, clean water directly into the tank. Do not pour anything but water into the water tank.

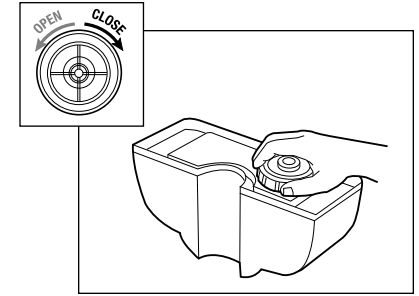

4. Close the tank lid, turning it to the right.

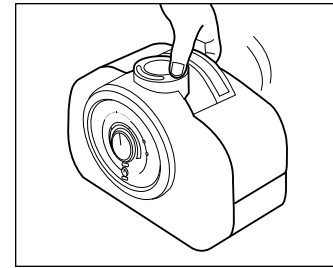

5. Attach the tank to the body of the unit and plug in.

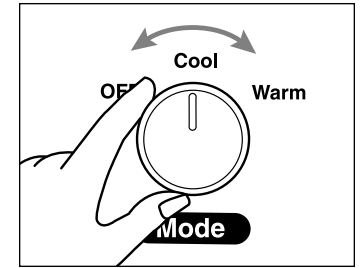

6. To select the temperature of humidity turn the mode dial to cool or warm. The Power LED will light up.

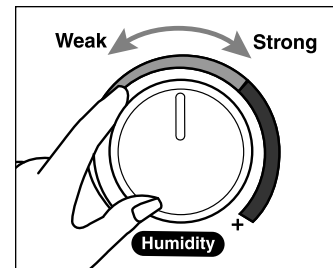

7. Turn the spray volume knob to the right to increase mist/humidity level. Turn left and the humidity/mist level decreases.

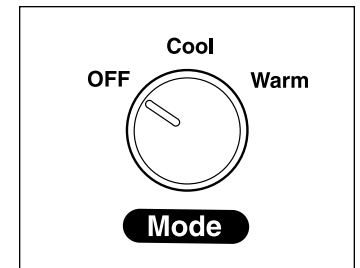

8. As soon as the Refill LED lights up, turn the unit off and refill the water tank.

## MAINTENANCE

- Always unplug the unit before servicing it in any way.
- The water temperature of the water remaining in the unit after use may be high.
- Do not submerge the unit in water, or allow water to enter the inside of the unit or humidity spout. Only put water into the water tank.

### INSIDE THE BODY OF THE UNIT

Pour excess water out of the unit, but do not allow it to enter the blast port. Wash out the unit with fresh water, using the cleaning brush and a soft cloth as needed.

### OUTER SURFACE OF THE UNIT

Wipe the surface of the unit with a soft damp cloth if needed.

### WATER TANK

If water spots remain in the water tank, wipe the inside down with a soft cloth. Do not use soap or detergents.

### AIR FILTER

Gently wipe away debris from the filter with a soft cloth.

### ULTRASONIC DISK

Remove water tank (Fig. 1) and use the enclosed cleaning brush to regularly remove build up and deposits from this area. (Fig. 2) Diluted white vinegar will help to prevent this build up.

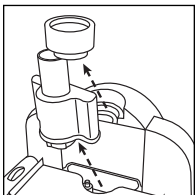

Fig. 1

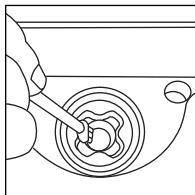

Fig. 2

**\*Clean the disk with the brush only. No other cleaning tool should be used. Brush only. (Fig. 2)**

## STORAGE

- Fully dry the inside and outside of the unit before storing it.
- DO NOT leave water in the unit.
- Store in a cool dry place.

## TROUBLESHOOTING GUIDE

PROBLEM	SOLUTION
Water mist & humidity are not produced.	Power Plug: Unplug and then try again. Power Failure: When the power is returned, try again. Water Tank Installation: Make sure the water tank is correctly attached. Make sure spring on tank cap moves freely when pushed.
Air blows but water mist is not produced.	Excessive Water: Remove water tank. Empty a small amount of water from the base of the unit. The desired humidity is lower than the current temperature: increase the desired humidity. Detergent residue in the water tank: Wash the water tank out and try again.
Humidity level is low.	The surface of the ultrasonic disk is dirty. Clean with white vinegar. The water in the unit is too cold: Replace with cool, but not cold water. The ultrasonic disk is damaged contact customer service at 866-603-5900.
Warm humidity is not produced.	It may take 10-15 min. before warm humidity is created. The mist may not feel warm to the touch. Check to see if base of unit feels warm to the touch. If so then warm mist is being produced.
The humidity has a bad smell.	Poor maintenance or dirty water: Clean the product thoroughly, and fill it with fresh water.
White dust is forming on nearby furniture.	Hard water may deposit a certain amount of dust. Dust in the air also settles because of added humidity in the room. <b>*Use distilled water if this becomes a nuisance.</b>  Or order a <b>Decalcification Filter (FLTDC)</b> by calling 1-866-603-5900 or visiting <a href="http://www.guardiantechnologies.com">www.guardiantechnologies.com</a>