

GTO/PRO[®] SL-1000

GTO/PRO[®] SL-2000



AUTOMATIC GATE OPERATOR

FOR VEHICULAR SLIDE GATES

INSTALLATION MANUAL FOR THE PROFESSIONAL INSTALLER

⚠ WARNING! ⚠

This equipment is similar to other gate or door equipment and meets or exceeds Underwriters Laboratory Standard 325 (UL 325). However, gate equipment has hazards associated with its use and therefore by installing this product the installer and user accept full responsibility for following and noting the installation and safety instructions. Failure to follow installation and safety instructions can result in hazards developing due to improper assembly. You agree to properly install this product and that if you fail to do so GTO, Inc. shall in no event be liable for direct, indirect, incidental, special or consequential damages or loss of profits whether based in contract tort or any other legal theory during the course of the warranty or at any time thereafter. The installer and/or user agree to assume responsibility for all liability and use of this product releasing GTO, Inc. from any and all liability. If you are not in agreement with this disclaimer or do not feel capable of properly following all installation and safety instructions you may return this product for full replacement value.

READ ALL INSTRUCTIONS CAREFULLY AND COMPLETELY before attempting to install and use this automatic gate opener. This gate opener produces a high level of force. Stay clear of the unit while it is operating and exercise caution at all times.

All automatic gate openers are intended for use on vehicular gates only.

This product meets and exceeds the requirements of UL 325, the standard which regulates gate opener safety, as established and made effective March 1, 2000, by Underwriters Laboratories Inc.

DO NOT INSTALL THIS OPERATOR WITHOUT SAFETY EDGES AND ROLLER GUARDS!



3121 Hartsfield Road • Tallahassee, Florida, USA 32303
Telephone GTO Sales: 1-800-543-GATE (4283) or (850) 575-0176 • Fax (850) 575-8912
or GTO Technical Service: 1-800-543-1236 or (850) 575-4144 • Fax (850)575-8950

GTO PRO SL-1000 and SL-2000 series automatic gate operators are intended for use with vehicular slide gates. These operators can be used in Class I, Class II and Class III applications.

VEHICULAR GATE OPERATOR CLASS CATEGORIES

Residential Vehicular Gate Operator-Class I: A vehicular gate operator (or system) intended for use in a home of one-to-four single family dwelling, or a garage or parking area associated therewith.

Commercial/General Access Vehicular Gate Operator-Class II: A vehicular gate operator (or system) intended for use in a commercial location or building such as a multifamily housing unit (five or more single family units), hotel, garages, retail store, or other building servicing the general public.

Industrial/Limited Access Vehicular Gate Operator-Class III: A vehicular gate operator (or system) intended for use in an industrial location or building such as a factory or loading dock area or other locations not intended to service the general public.

Restricted Access Vehicular Gate Operator-Class IV: A vehicular gate operator (or system) intended for use in a guarded industrial location or building such as an airport security area or other restricted access locations not servicing the general public, in which unauthorized access is prevented via supervision by security personnel.

Conversion Chart

| <i>Converting Metric Units to English Equivalents</i> | | | |
|---|--------------------------------------|-----------------|--------------------|
| When You Know | Multiply By | To Find | Symbol |
| centimeters | 0.3937 | inches | in. (or ") |
| meters | 3.2808 | feet | ft. (or') |
| kilograms | 2.2046 | pounds | lb. (or #) |
| <i>Converting English Units to Metric Equivalents</i> | | | |
| When You Know | Multiply By | To Find | Symbol |
| inches | 2.5400 | centimeters | cm |
| feet | 0.3048 | meters | m |
| pounds | 0.4535 | kilograms | kg |
| <i>Temperature</i> | | | |
| deg. Celsius | $(^{\circ}\text{C} \times 1.8) + 32$ | deg. Fahrenheit | $^{\circ}\text{F}$ |
| deg. Fahrenheit | $(^{\circ}\text{F} - 32) / 1.8$ | deg. Celsius | $^{\circ}\text{C}$ |

TABLE OF CONTENTS

| | |
|---|-------------------|
| Gate Operator Class Categories | inside cover |
| Important Safety Instructions | page 1 |
| Important Safety Instructions for the System Designer | page 2 |
| Important Safety Instructions for the Installer | page 2 |
| Secondary means of Protection Against Entrapment | page 4 |
| Important Safety Instructions for the Consumer/End User | page 5 |
| Warning Labels and Signs | page 7 |
| Technical Specifications for SL-1000 | page 9 |
| Technical Specifications for SL-2000 | page 10 |
| Parts Identification (Single Gate Operator) | page 11 |
| Single Gate Operator Installation | page 12 |
| Overview and Gate Preparation | page 12 |
| Suggested Conduit & Wiring and Mounting the Legs | page 13 |
| Determining the Mounting Position and Mounting the Operator | page 14 |
| Installing the Chain | page 15 |
| Disconnecting Operator Chain for Manual Operation of Gate | page 15 |
| Powering the System | page 16 |
| Maximum Operational Cycles Chart | page 16 |
| Installation of the Transformer | page 16 |
| Control Board settings | page 20 |
| DIP Switches | page 20 |
| Potentiometers | page 21 |
| Connecting the Receiver to the Control Board | page 22 |
| Setting Your Personal Transmitter Code | page 22 |
| Mounting the Receiver | page 23 |
| Adjusting the Limit Switches | page 24 |
| Connecting Safety Devices | page 25 |
| Connecting Accessories | page 26 |
| Maintenance | page 28 |
| Troubleshooting Guide | page 29 |
| Warranty and Repair Information | page 31 |
| Dual Gate System Installation | page 32 |
| Preparing the Gates | page 34 |
| Wiring the Second Operator | page 35 |
| Setting the Control Board for Dual Gate Installations | page 36 |
| Accessory Catalog | page 38 |
| Installation Check List | inside back cover |

IMPORTANT SAFETY INSTRUCTIONS

FOR THE GTO/PRO SL-1000/2000 AND GTO/PRO SL-1000B/2000B AUTOMATIC SLIDE GATE OPERATORS

Because automatic gate operators produce high levels of force, all system designers, installers, and consumers have an obligation to know the potential hazards associated with improperly designed, installed, or maintained gate operator systems. **Keep in mind that the gate operator is just one component of the total gate operating system.** Each component must work in unison to provide the consumer with convenience, security, and safety.

This manual contains various safety precautions and warnings for the system designer, installer, and consumer. Because there are many possible applications of the gate operator, the safety precautions and warnings contained in this manual cannot be completely exhaustive in nature. They do, however, provide an overview of the safe design, installation, and use of this product. **CAREFULLY READ AND FOLLOW ALL SAFETY PRECAUTIONS, WARNINGS, AND INSTALLATION INSTRUCTIONS TO ENSURE THE SAFE SYSTEM DESIGN, INSTALLATION, AND USE OF THIS PRODUCT.**

The precautions and warnings in this manual are identified with this  warning symbol.

The  symbol identifies the conditions that can result in damage to the operator or its components, serious injury, or death.

Because GTO automatic gate operators are only part of a total gate operating system, it is the responsibility of the designer, installer, and purchaser to ensure the total system is safe for its intended use. Bypassing safety devices or neglecting to use safety devices with the gate operator is NOT acceptable.

TO MANUALLY OPEN AND CLOSE THE GATE, FOLLOW THE PROCEDURE BELOW:

 **CAUTION: Disconnect the operator chain ONLY when the gate is NOT moving.**

1. Lift the quick release pins **UP**, then pull them **OUT** of the chain brackets (see illustration).
2. Lay the chain down and manually slide the gate to the desired position.

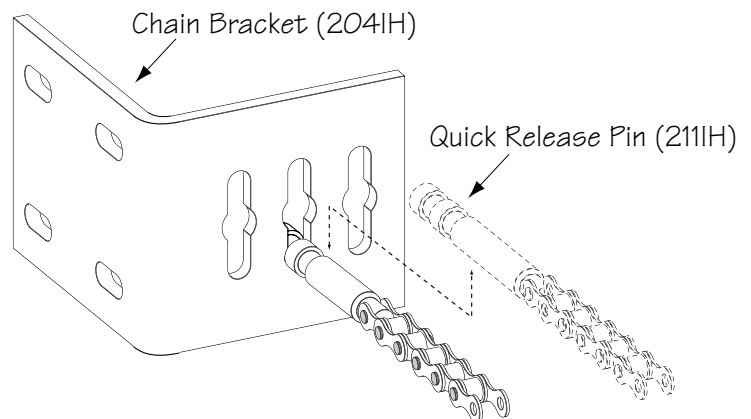

To prevent unauthorized removal of the quick release pins, install pin locks (see accessory catalog) above the quick release pins in both chain brackets.

IMPORTANT SAFETY INSTRUCTIONS

FOR THE SYSTEM DESIGNER

WARNING: To reduce the risk of injury or death:

1. **READ AND FOLLOW ALL INSTRUCTIONS.**
-  2. This operator is intended for use only on vehicular gates. **Pedestrians** must be supplied with a separate **walk-through** gate (*see Entrapment Protection on page 6*).
3. When designing a system that will be entered from a highway or main thoroughfare, make sure the system is placed far enough from the road to prevent traffic congestion.





FOR THE INSTALLER

WARNING-To reduce the risk of injury or death:

I. Before Installation

1. **READ AND FOLLOW ALL INSTRUCTIONS.**
2. Verify this operator is proper for the type and size of gate, and its frequency of use.
3. Make sure the gate has been properly installed and slides freely in both directions. Repair or replace all worn or damaged gate hardware prior to installation. A freely moving gate will require less force to operate and will enhance the performance of the operator and safety devices used with the system.
4. All openings of a horizontal slide gate must be guarded or screened to prevent a 2¼ inch diameter sphere from passing through openings anywhere in the gate. This screen (or guard) must also be installed over the portion of adjacent fence that the gate covers in the open position (*see page 6*).
-  5. Review the operation of the system and become familiar with its safety features. Understand how to disconnect the operator chain with the quick release pins for manual operation of the gate (*see page 1*).
6. This gate operator is intended for vehicular gates **ONLY**. A separate entrance or gate must be installed for pedestrian use (*see page 6*). **NO ONE SHOULD CROSS THE PATH OF A MOVING GATE.**

II. During Installation

1. Install the gate operator on the inside of the property and fence line. **DO NOT** install an operator on the outside of the gate where the public has access to it.
-  2. Be careful with moving parts and avoid close proximity to areas where fingers or hands could be pinched.
-  3. Determine the best obstruction sensing setting for this installation. The gate **MUST** stop and reverse on contact with an obstruction or when an object activates the non-contact sensors. After adjusting the force or the limit of travel, retest the gate operator. **Failure to adjust and retest the gate operator properly increases the risk of injury or death.**
-  4. **Additional safety equipment such as roller guards and safety edges (or photoelectric sensors) MUST be installed to prevent bodily injury** (*see page 6*).
-  5. Mount access controls away from the gate (**minimum** distance is 10 feet). The user must have full view of the gate but be unable to touch it while operating the controls.

IMPORTANT SAFETY INSTRUCTIONS

6. Secure outdoor or easily accessed gate operator controls in order to prohibit unauthorized use of the gate.

III. After Installation

1. Review **ALL** safety instructions with the consumer/end user and explain the basic operation and safety systems of the entire gate operator system, including disconnecting the chain for manual gate operation.
2. Inform the consumer/end user that servicing of the operator must only be done by an *experienced technician*.
3. Attach the **warning signs** (included) to each side of the gate to alert public of automatic gate operation. Take a photo of warning signs installed on gate. Record the date of the photo for your reference.
4. **SAVE THESE INSTRUCTIONS.** Leave **IMPORTANT SAFETY INSTRUCTIONS** (included) with consumer/end user.

IMPORTANT SAFETY INSTRUCTIONS

SECONDARY MEANS OF PROTECTION AGAINST ENTRAPMENT

As specified by Underwriters Laboratories Inc. UL 325 (31.1.1), automatic gate operators shall have *provisions for, or be supplied with*, at least one independent primary and one independent secondary means to protect against entrapment. GTO gate operators utilize **Type A**, an inherent entrapment sensing system, as the **primary** type of entrapment protection. The GTO/PRO SL-1000/2000 and GTO/PRO SL-1000B/2000B gate operators have provisions for the connection of **Type B1** and **B2** protection to be used as the **secondary** type of entrapment protection.

1. For gate operators utilizing a non-contact sensor (Type B1) in accordance with UL 325 (31.1.6):
 - A. Refer to the *sensor manufacturer's instructions* on the placement of non-contact sensors for each type of application.
 - B. Care shall be exercised to reduce the risk of nuisance tripping, such as when a vehicle trips the sensor while the gate is still moving.
 - C. One or more non-contact sensors shall be located where the risk of entrapment or obstruction exists, such as the perimeter reachable by a moving gate or barrier.
2. For gate operators utilizing a contact sensor (Type B2) in accordance with UL 325 (31.1.10):
 - A. One or more contact sensors shall be located at the leading edge, trailing edge, and post mounted edge, both inside and outside of a vehicular slide gate system.
 - B. A hard wired contact sensor shall be located and its wiring arranged so that the communication between the sensor and the gate operator is not subjected to mechanical damage.
 - C. A wireless contact sensor such as one that transmits radio frequency (RF) signals to the gate operator for entrapment protection functions shall be located where the transmission of the signals are not obstructed or impeded by building structures, natural landscaping or similar obstruction. A wireless contact sensor shall function under the intended end-use conditions.

ENTRAPMENT ALARM (UL 325; 31.2.1)

The GTO/PRO SL-2000 and GTO/PRO SL-2000B operators are designed to stop and reverse for 2 seconds when the gate comes in contact with an obstruction or when an object activates the non-contact sensors. Additionally, these operators are equipped with an audio entrapment alarm which will function if the unit obstructs **twice** while opening or closing. This alarm will sound for a period of 5 minutes or until the operator receives an intended signal (e.g., transmitter signal) and the gate returns to a fully open or fully closed position.

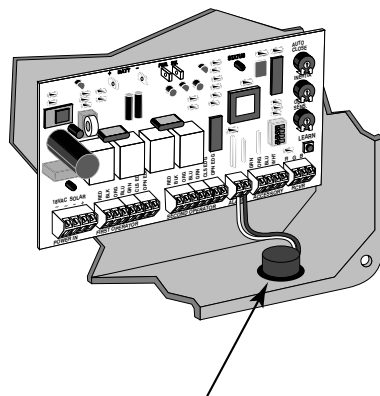

Entrapment Alarm
(bottom right of control box)

IMPORTANT SAFETY INSTRUCTIONS

FOR THE CONSUMER/END USER

WARNING: To reduce the risk of injury or death:

1. **READ AND FOLLOW ALL INSTRUCTIONS.**
2. Distribute and discuss copies of the **IMPORTANT SAFETY INSTRUCTIONS** manual with all persons authorized to use your gate. **SAVE THESE INSTRUCTIONS.**
3. Always keep people and objects away from the gate and its area of travel. **NO ONE SHOULD CROSS THE PATH OF THE MOVING GATE.**
4. Your automatic gate is not for pedestrian use. If **pedestrian** traffic is expected near the gate, a **walk-through** gate must be installed for this purpose (*see page 6*).
5. Do not allow children or pets near your gate. **Never let children operate or play with gate controls.** Keep the remote controls away from children and unauthorized users; store controls where children and unauthorized users cannot access them.
6. If push buttons or key switches are installed, they should be within sight of the gate, yet located far enough from the gate (at least 10 feet) so the gate cannot be touched while in operation. Do not operate any control without watching the movement of the gate.
7. Do not activate your gate operator unless you can see it and can determine that its area of travel is clear of people, pets, or other obstructions.
8. If your gate has open rollers, be sure that roller guards have been installed to prevent hands and fingers from being caught in the rollers (*see page 6*).
9. It is your responsibility to make sure that the installer posted warning signs on both sides of your gate. If any of these signs or warning decals become damaged, illegible or missing, replace them immediately. Contact your installer or GTO for replacements.
10. Verify that electric safety edge sensors (or photoelectric sensors) have been installed (*see page 6*). These safety devices should be tested monthly.
11. **KEEP GATES PROPERLY MAINTAINED.** Have a qualified service person make repairs to the gate hardware. **NEVER REMOVE THE OPERATOR HOUSING.**
12. **DO NOT** attempt to service this operator yourself; for service, contact your installer or another experienced technician.
13. Have your gate operator tested monthly and serviced regularly by an experienced technician. The gate **MUST** stop and reverse on contact with an obstruction or when an object activates the non-contact sensors. If these functions are observed to operate improperly, discontinue use and have operator serviced immediately.
14. To operate this equipment safely, **YOU** must receive detailed instructions on disconnecting the operator chain with the quick release pins (*see page 1*). If you feel you have not received full and proper instructions, contact your installer.
15. Disconnect the operator chain **ONLY** when the gate is **NOT** moving and turned off.

IMPORTANT SAFETY INSTRUCTIONS

REQUIRED SAFETY PRECAUTIONS FOR GATES

INSTALL SCREEN GUARD OVER GATE AND FENCE

Injuries may occur when people place their hands, arms, legs, etc., through openings in the gate grill when the gate is operated, trapping them between the grill and the fence post (or fence). All openings of a horizontal slide gate must be guarded or screened to prevent a 2 1/4" diameter sphere from passing through openings anywhere in the gate. This screen/guard must also be installed over the portion of adjacent fence that the gate covers in the open position. Screening will prevent access through openings in areas where the gate may travel.

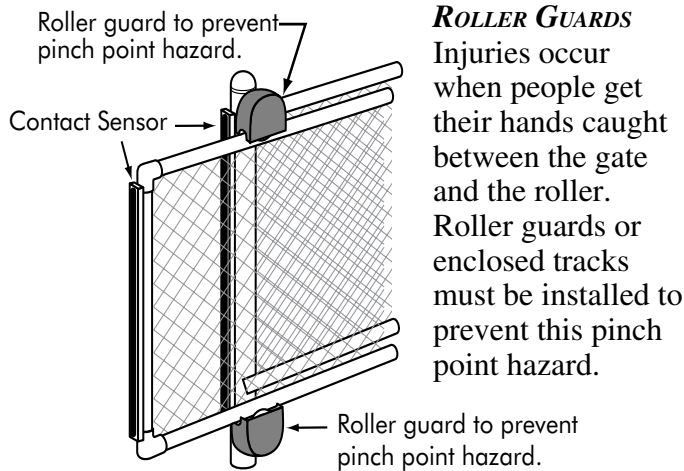
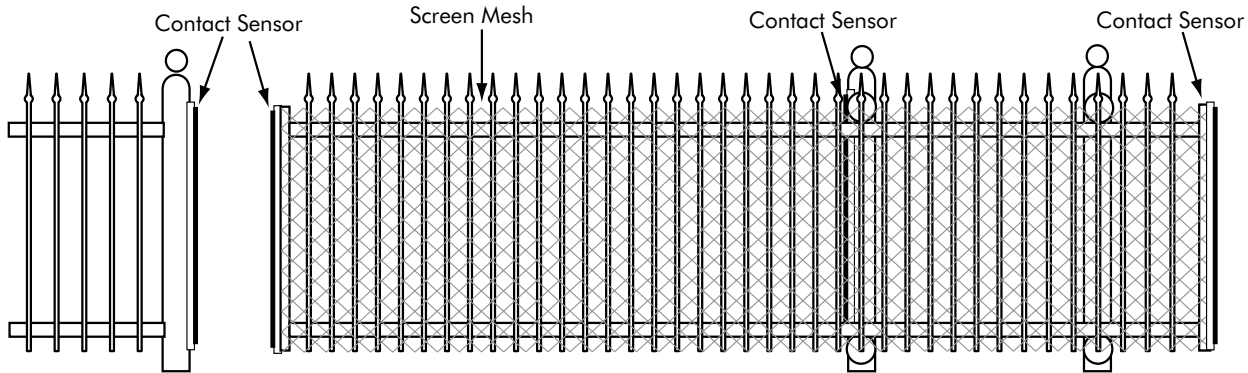

WARNING SIGNS

The warning signs (above right) must be installed on both sides of the gate (see page 7 for details).

ENTRAPMENT PROTECTION

GTO's internal obstruction settings, even when properly adjusted, **may not be sensitive enough to prevent bodily injury**. For this reason, safety devices such as **safety edges MUST be installed**. Furthermore, a pedestrian gate must be installed if walk-through traffic is expected near the gate. We recommend the **GTO Bulldog Pedestrian Gate Lock** (see accessory catalog) for controlled access.

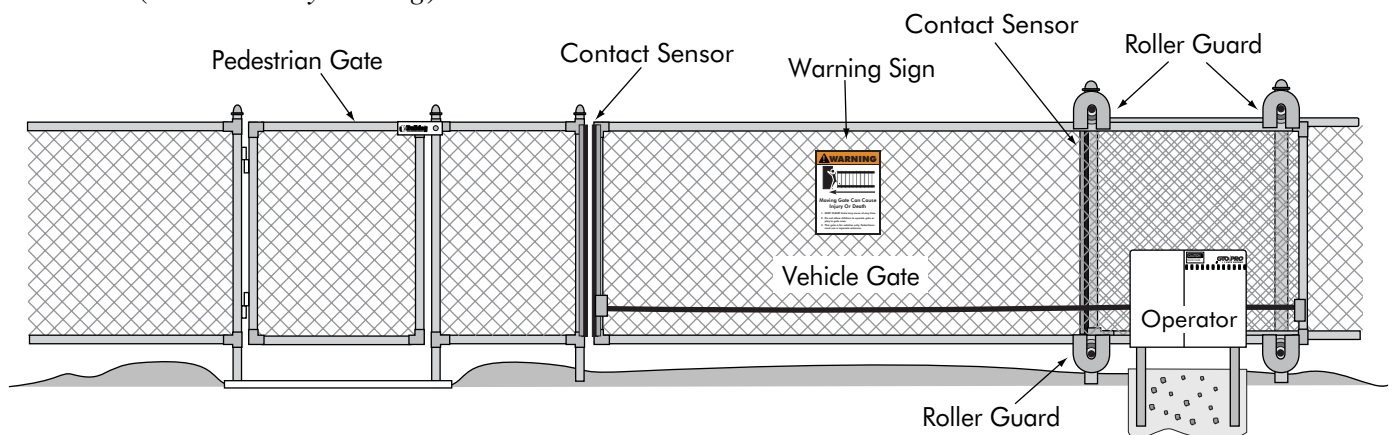

IMPORTANT SAFETY INSTRUCTIONS

These warning labels should be found at the locations specified below. If any of them are missing, immediately contact your installer for replacements.



warning labels (3). Located on both sides and back of operator housing



warning label located on front of operator housing

GTO-SL1000 Series
Conforms to UL 325 STANDARDS
Certified to CAN/CSA-C22.2 No.247-92

Maximum Gate: 500 lb. (226.7 kg); 30 ft. (9.1 m)
 Voltage: 12 Vdc; Frequency: 0 Hz; Power: 93.2 W
 Class I, II and III Vehicular Slide Gate Operator
 Serial Number: SL1000-xxxxxxx

Disconnect operator ONLY when the gate is NOT moving.

TO MANUALLY OPEN AND CLOSE THE GATE:
 1. Lift quick release pins UP, then pull them OUT of chain brackets.
 2. Lay chain down and manually slide gate to desired position.

GTO, Inc. Tallahassee, Florida USA RB2001



warning label located on top of control box

GTO-SL2000 Series
Conforms to UL 325 STANDARDS
Certified to CAN/CSA-C22.2 No.247-92

Maximum Gate: 1000 lb. (453.4 kg); 30 ft. (9.1 m)
 Voltage: 12 Vdc; Frequency: 0 Hz; Power: 93.2 W
 Class I, II and III Vehicular Slide Gate Operator
 Serial Number: SL2000-xxxxxxx

Disconnect operator ONLY when the gate is NOT moving.

TO MANUALLY OPEN AND CLOSE THE GATE:
 1. Lift quick release pins UP, then pull them OUT of chain brackets.
 2. Lay chain down and manually slide gate to desired position.

GTO, Inc. Tallahassee, Florida USA RB2002

product identification and manual operation instruction label installed on control box cover

IMPORTANT SAFETY INSTRUCTIONS

Continued from page 7

These warning labels should be found at the locations specified below. If any of them are missing, immediately contact your installer for replacements.



warning signs (2) to be installed on each side of the gate (3–5 feet above the bottom of the gate)

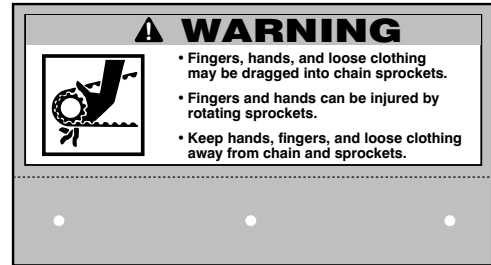

warning sign located (inside housing) over the top sprocket at back of operator

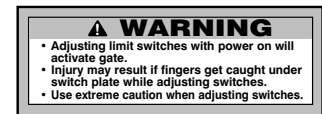

warning label located on limit switch plate



warning label located (inside housing) next to sprockets on back of operator

GTO PRO SL-1000 SERIES TECHNICAL SPECIFICATIONS

DRIVE

- Powered by a 12 V motor with integral case hardened steel gear reduction to 90 rpm. Generates 155 in. lb. of torque at 12 V. Motor temperature range -30 °F to +160 °F.
- Gate velocity: 1 ft/s.

POWER

- The **PRO SL-1000** system is powered by a 12 Vdc, 7.0 Ah, sealed, rechargeable battery.
- Battery charge for **PRO SL-1000** is maintained by a 18 Vac (40 VA) transformer rectified to 14.5 Vdc through the **GTO** Control Board. Two (2) blade-style control board fuses rated for 15 A.

NOTE: The transformer should not be connected *directly* to any battery. Transformer must be connected with a minimum of 16 gauge, multi-stranded, dual conductor, direct burial low voltage wire. NOTE: Do not replace fuses with higher ampere rated fuses; doing so will void the warranty and may damage the control board.

- Battery charge maintained by **GTO** Solar Panel Charger: float voltage 14.5 Vdc output from a 19³/₈" x 15¹/₄" silicon alloy panel. Generates minimum of 10 W at 600 mA. Gated diode on the control board prevents battery discharge.

CONTROL

- **GTO** microprocessor controlled board with temperature compensated circuits. Auto-memorization of digital transmitter code. Charging regulated by circuit on control board. "Sleep draw" is 40 mA; "active draw" is 2 to 5 A.
- **GTO** remote-mounted RF receiver tuned to 318 MHz.
- Limit controls are mechanical. Normally open contact.
- Adjustable auto-close timer (**OFF** to 120 s), inertia, and obstruction sensitivity using three (3) potentiometers.
- Power terminal block accommodates a transformer and solar panels.
- Operator terminal blocks accommodate safety edges and photoelectric sensors for opening and closing modes.
- Fully compatible accessory terminal block provides connections for safety loops, wands, intercoms, card readers, phone systems, etc.
- DIP switches simplify setup of gate operator.
- audio entrapment alarm sounds if unit obstructs twice while opening or closing.

OPERATIONAL CAPACITY

- The **GTO/PRO SL-1000** and **GTO/PRO SL-1000B** will handle gates weighing up to 500 lb. (226.7 kg) and up to 30 ft. (9.14 m) in length (per leaf) **if the proper installation procedures have been followed**. Note that ball bearing rollers and covers should be used on all gates.
- The **GTO/PRO SL-1000** series operators are capable high volume cycling; however, the total cycles per day will depend on the motor current and efficiency of the gate installation (*see chart below*). For questions relating to specific applications and for information regarding cycling duty when charged by solar panels, call the GTO Service Department at (800) 543-1236.

| Gate Capacity Chart for SL-1000 Series | | | | | |
|---|--------|---------|---------|---------|---------|
| <i>(estimated number of cycles based on use with a transformer)</i> | | | | | |
| Gate Opening | 20 ft. | 120 | 110 | 100 | 90 |
| | 16 ft. | 140 | 130 | 120 | 110 |
| | 12 ft. | 160 | 150 | 140 | 130 |
| | 8 ft. | 180 | 170 | 160 | 150 |
| | | 200 lb. | 300 lb. | 400 lb. | 500 lb. |
| Gate Weight | | | | | |

Cycles shown are for single gate, dual gates will get approximately half as many cycles.

| | |
|----------------------------|--|
| Housing Dimensions: | Height: 18" Width: 21 ¹ / ₂ " Depth: 11" |
| Shipping Weight: | Approximately 90 lb. |

Rollers should be lubricated at least four times per year.
SPECIFICATIONS SUBJECT TO CHANGE WITHOUT NOTICE.

GTO PRO SL-2000 SERIES TECHNICAL SPECIFICATIONS

DRIVE

- Powered by a 12 V motor with integral case hardened steel gear reduction to 90 rpm. Generates 310 in. lb. of torque at 12 V. Motor temperature range -30 °F to +160 °F.
- Gate velocity: 1 ft/s.

POWER

- The **PRO SL-2000** system is powered by a 12 Vdc, 7.0 Ah, sealed, rechargeable battery.
- Battery charge for **PRO SL-2000** is maintained by a 18 Vac (40 VA) transformer rectified to 14.5 Vdc through the **GTO Control Board**. Two (2) blade-style control board fuses rated for 20 A.
IMPORTANT: The transformer should not be connected directly to any battery. Transformer must be connected to the control board with a minimum of 16 gauge, multi-stranded, dual conductor, direct burial low voltage wire. Do not replace fuses with higher ampere rated fuses; doing so will void the warranty and may damage the control board.
- **Solar Panel Charger can only be used on the SL-2000 if the optional 24 Amp hour battery kit is used** (see Accessory Catalog on page 41). Battery charge maintained by **GTO Solar Panel Charger**: float voltage 14.5 Vdc output from a 19³/₈" x 15¹/₄" silicon alloy panel. Generates minimum of 10 W at 600 mA. Gated diode on the control board prevents battery discharge.

CONTROL

- **GTO** microprocessor controlled board with temperature compensated circuits. Auto-memorization of digital transmitter code. Charging regulated by circuit on control board. "Sleep draw" is 40 mA; "active draw" is 5 to 13 A.
- **GTO** remote-mounted RF receiver tuned to 318 MHz.
- Limit controls are mechanical. Normally open contact.
- Adjustable auto-close timer (**OFF** to 120 s), inertia, and obstruction sensitivity using three (3) potentiometers.
- Power terminal block accommodates a transformer and solar panels.
- Operator terminal blocks accommodate safety edges and photoelectric sensors for opening and closing modes.
- Fully compatible accessory terminal block provides connections for safety loops, wands, intercoms, card readers, phone systems, etc.
- DIP switches simplify setup of gate operator.
- audio entrapment alarm sounds if unit obstructs twice while opening or closing.

OPERATIONAL CAPACITY

- The **GTO/PRO SL-2000** and **GTO/PRO SL-2000B** will handle gates weighing up to 1000 lb. (453.4 kg) and up to 30 ft. (9.14 m) in length (per leaf) **if the proper installation procedures have been followed**. Note that ball bearing rollers and covers should be used on all gates.
- The **GTO/PRO SL-2000** series operators are capable of high volume cycling; however, the total cycles per day will depend on the motor current and efficiency of the gate installation (*see chart below*). For questions relating to specific applications and for information regarding cycling duty when charged by solar panels, call the GTO Service Department at (800) 543-1236.

| Gate Capacity Chart for SL-2000 Series | | | | | |
|---|----------------|----------------|----------------|-----------------|------------|
| <i>(estimated number of cycles based on use with a transformer)</i> | | | | | |
| Gate Opening | 20 ft. | 80 | 70 | 60 | 50 |
| | 16 ft. | 100 | 90 | 80 | 70 |
| | 12 ft. | 120 | 110 | 100 | 90 |
| | 8 ft. | 140 | 130 | 120 | 110 |
| | 400 lb. | 600 lb. | 800 lb. | 1000 lb. | |
| Gate Weight | | | | | |

Cycles shown are for single gate, dual gates will get approximately half as many cycles.

| | |
|----------------------------|--|
| Housing Dimensions: | Height: 18" Width: 21 ¹ / ₂ " Depth: 11" |
| Shipping Weight: | Approximately 90 lb. |

Rollers should be lubricated at least four times per year.
SPECIFICATIONS SUBJECT TO CHANGE WITHOUT NOTICE.

PARTS IDENTIFICATION

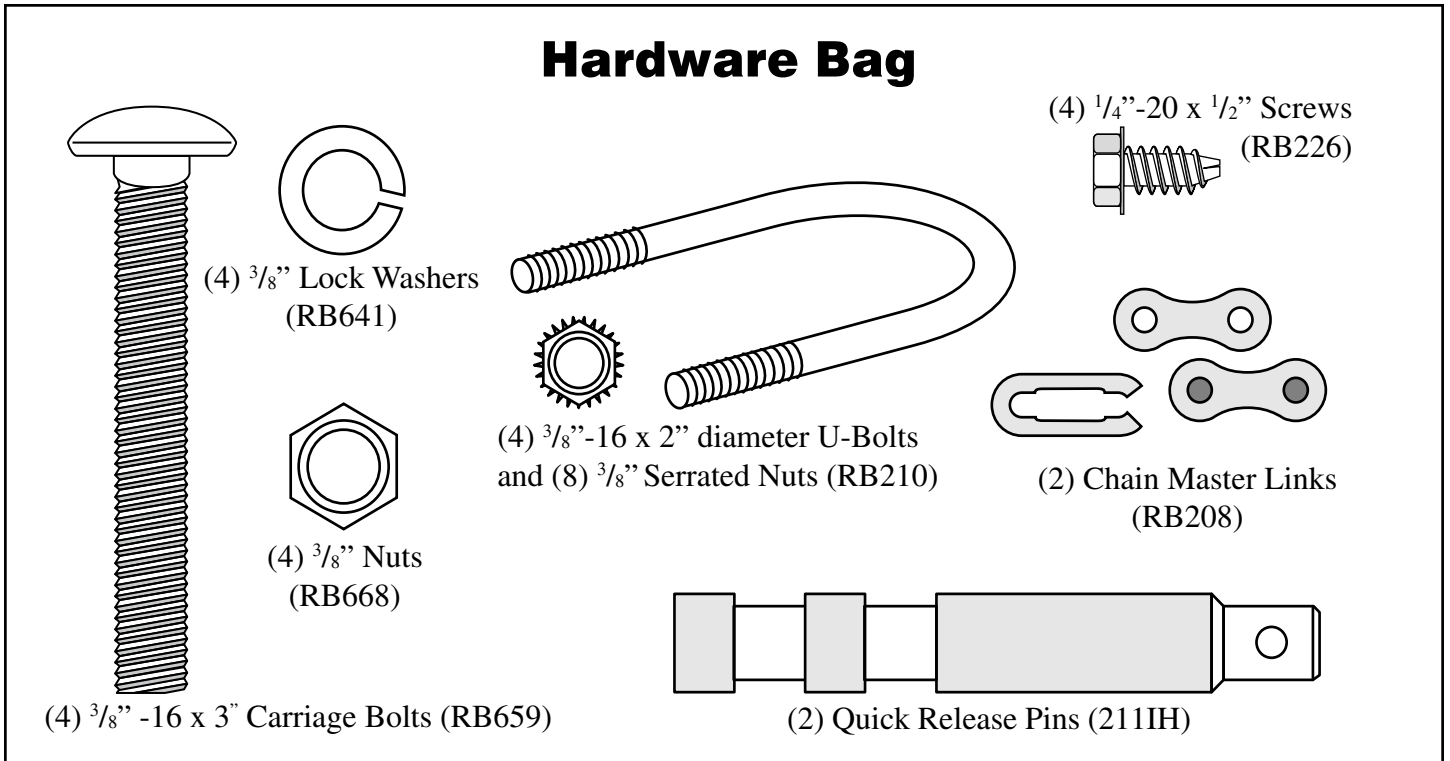
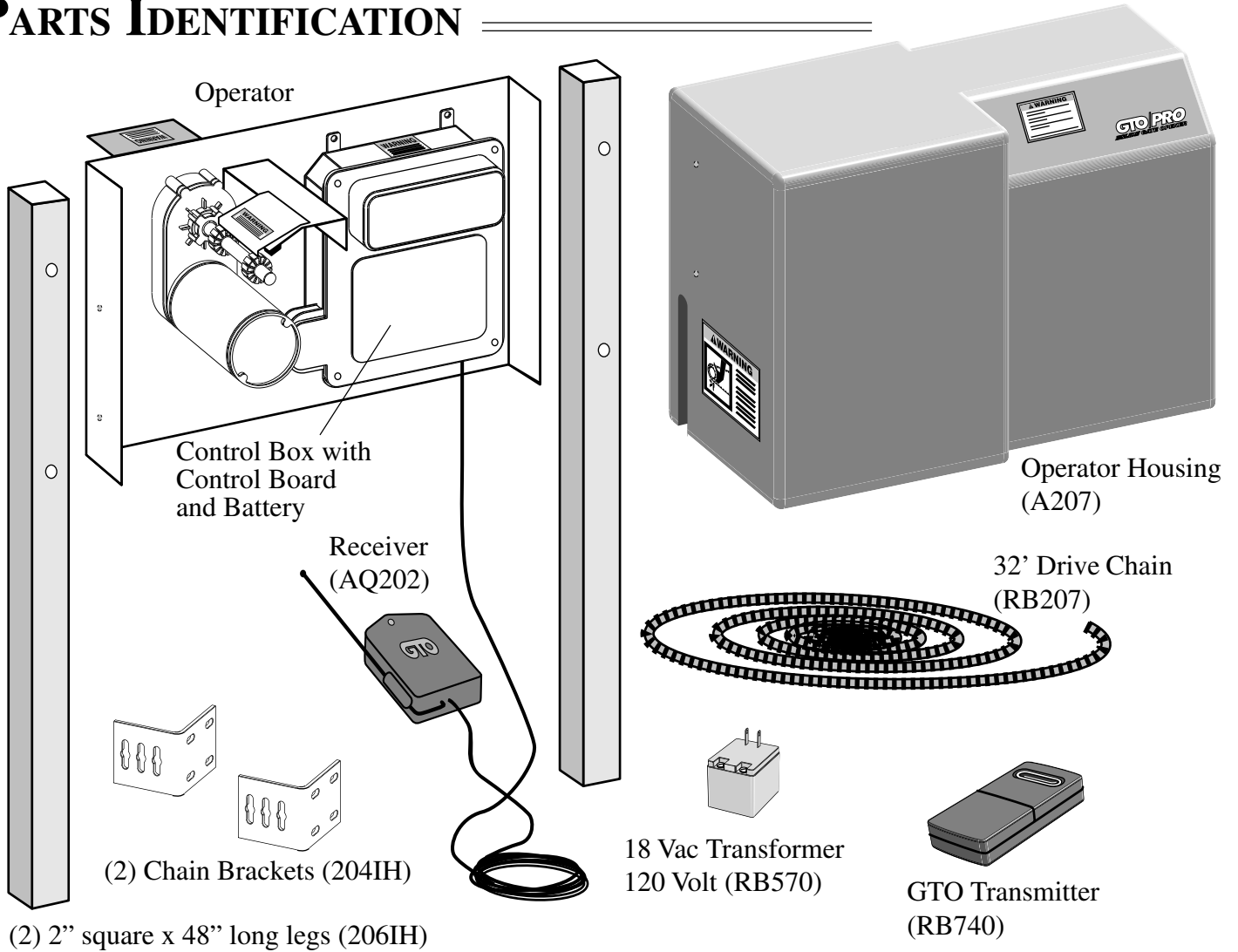

SINGLE GATE OPERATOR INSTALLATION

GATE PREPARATION

Be sure the gate is properly installed and slides smoothly before installing the GTO/PRO Slide Gate Operator. The gate must be plumb, level, and move freely. **The gate must not bind or drag on the ground.** Never use a wheel on the gate, because the additional drag and resistance can cause the operator to obstruct.

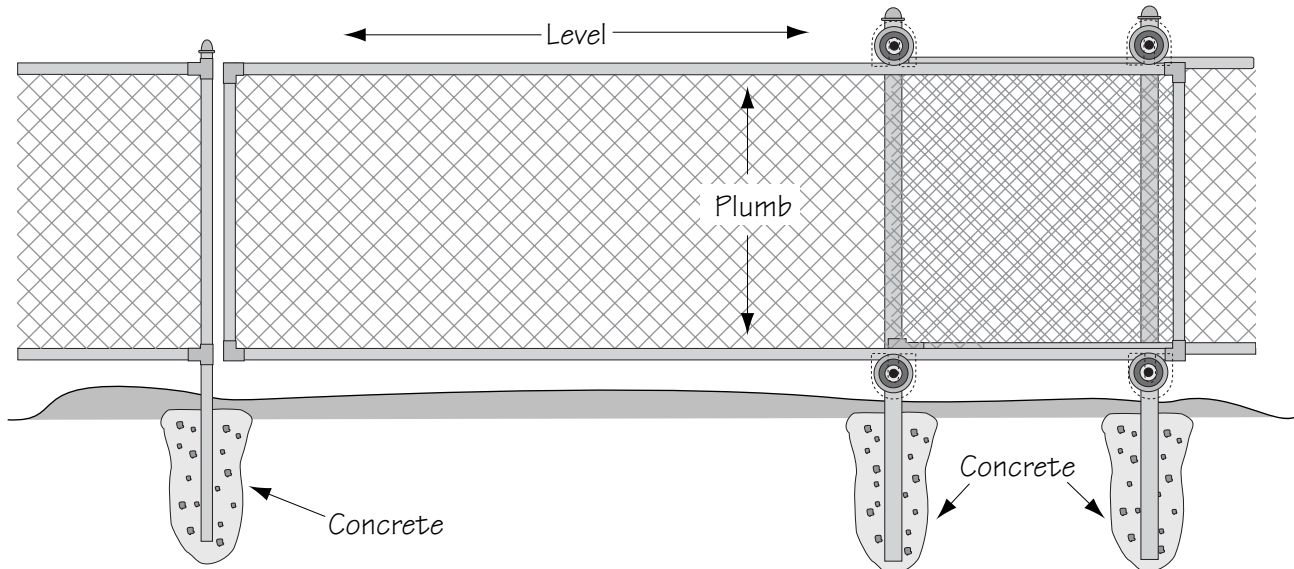

OVERVIEW OF OPERATOR INSTALLATION

The diagram below shows a single slide gate installation with recommended safety features. The operator must be installed on the **inside** of the gate. **GTO requires using safety edges and roller guards to help reduce the possibility of bodily injury.**

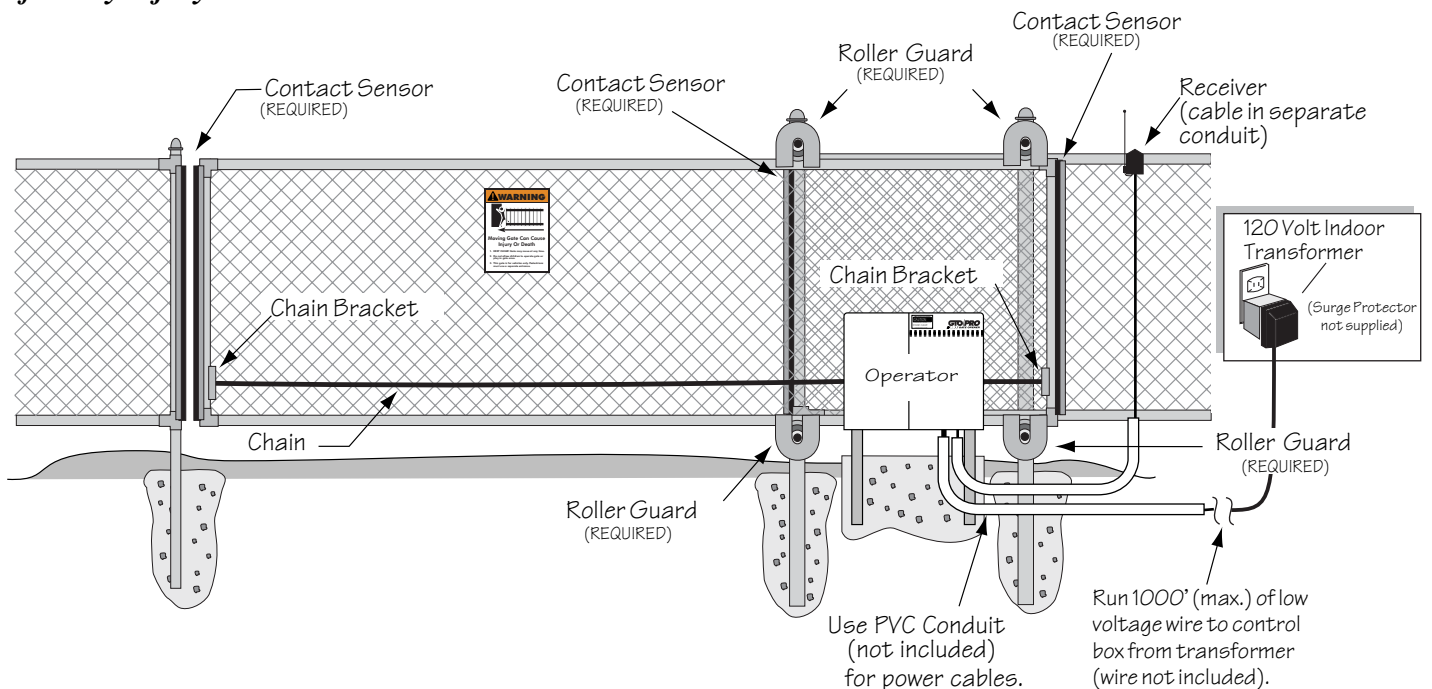

RECOMMENDED WIRING AND USE OF CONDUIT

Run the low voltage wire and receiver wire through PVC conduit into the slider unit to protect it from lawn mowers, weed eaters, grazing animals, etc. PVC conduit should be used for accessory wires such as loop detectors, key pads, card readers or any other entry device.

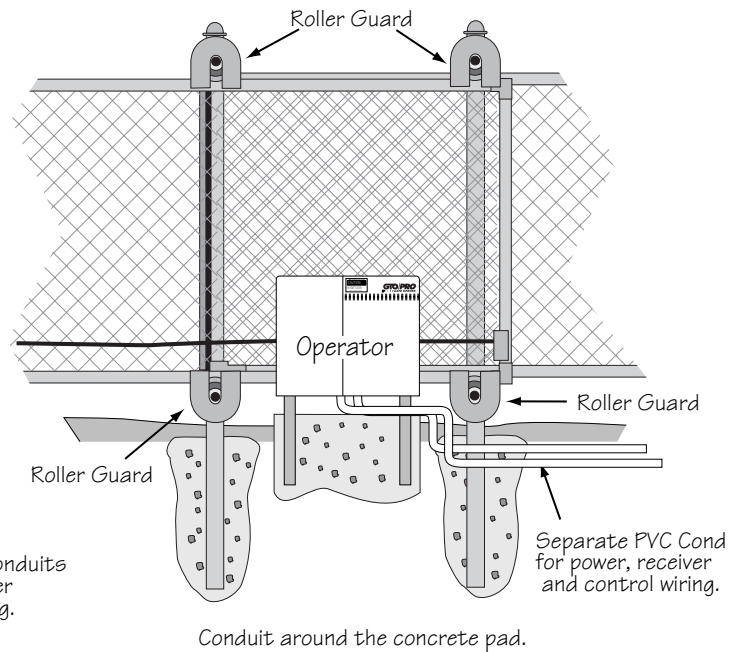
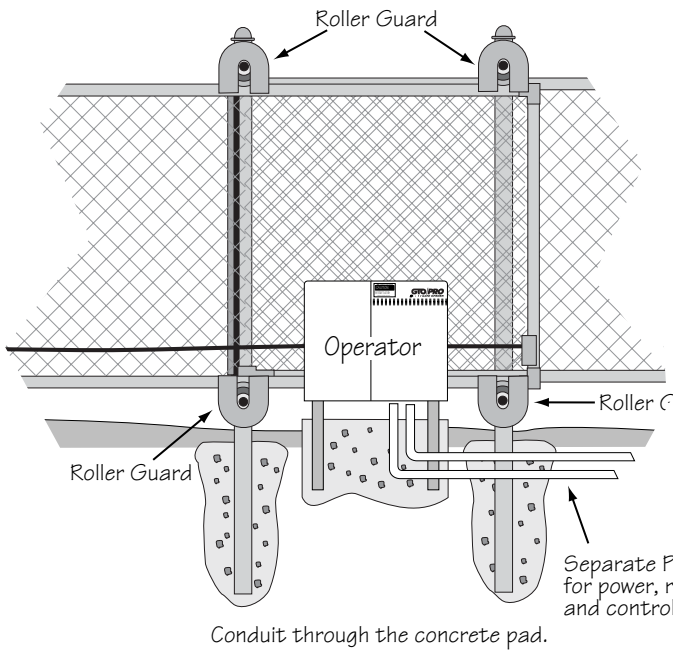

MOUNTING THE LEGS ON THE SLIDE GATE OPERATOR

STEP 1

Mount the legs on the slide gate operator using the $\frac{3}{8}$ " x 3" Carriage Bolts, $\frac{3}{8}$ " Flat Washers, $\frac{3}{8}$ " Lock Washers, and $\frac{3}{8}$ " Nuts. See *Illustration A*.

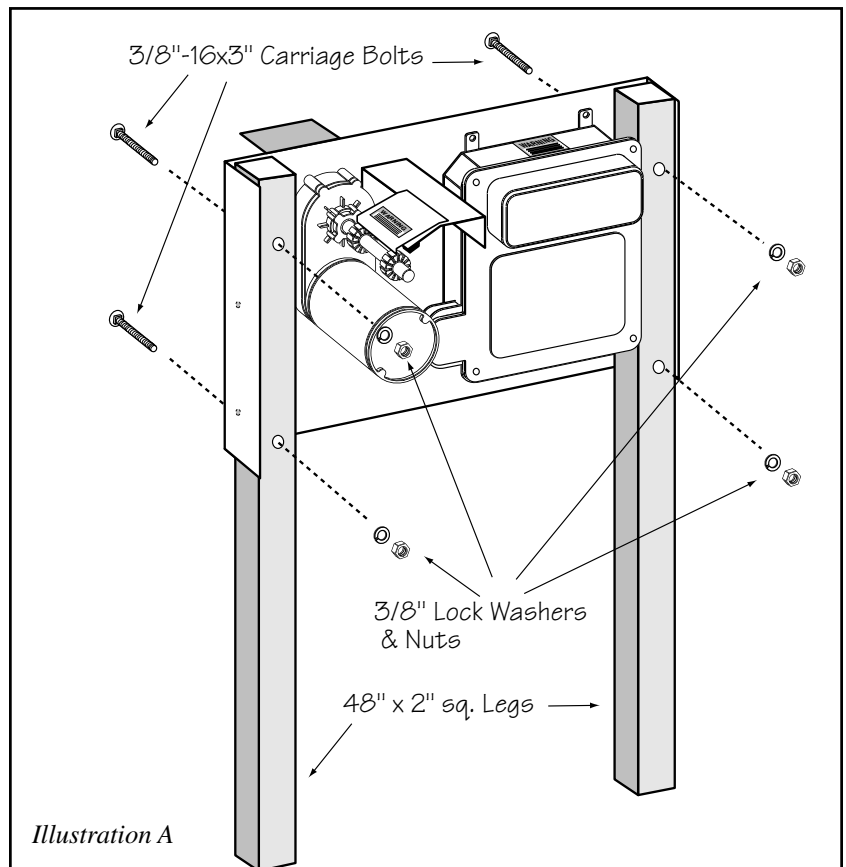

DETERMINING THE MOUNTING POSITION AND MOUNTING THE OPERATOR

STEP 2

Install chain brackets at each end of the gate on the inside (operator side) of the gate (see *Overview Illustration*, page 12). Position the tops of chain brackets no more than 6" above the bottom corners of the gate frame and secure with U-bolts (see *Illustration B*). The chain brackets will work on gate frames 1³/₄" to 2¹/₂" in diameter or square tube gates. The U-bolts provided will work on 2" diameter pipe gate frames.

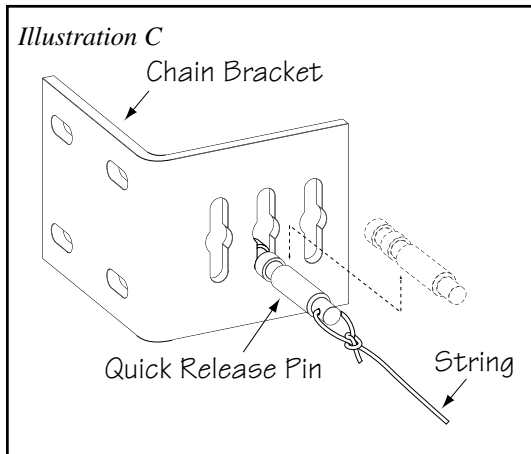
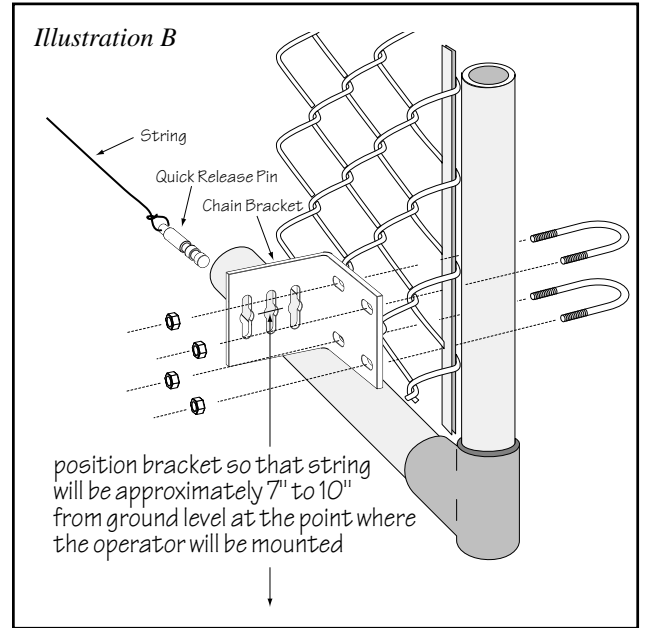

STEP 3

Insert a quick release pin into the center slot in each of the chain brackets (see *Illustration C*). Tie a string to the end of each quick release pin so that the string is tight between the two chain brackets (the string will be used to align the operator). The string should be 7"-10" from the ground (see *Illustration B*). The chain brackets can be adjusted up or down on the gate to achieve the proper height. The goal here is to set the height of the operator so that when the housing is in place it will clear the ground by 1" to 4" (see *Illustration E*).

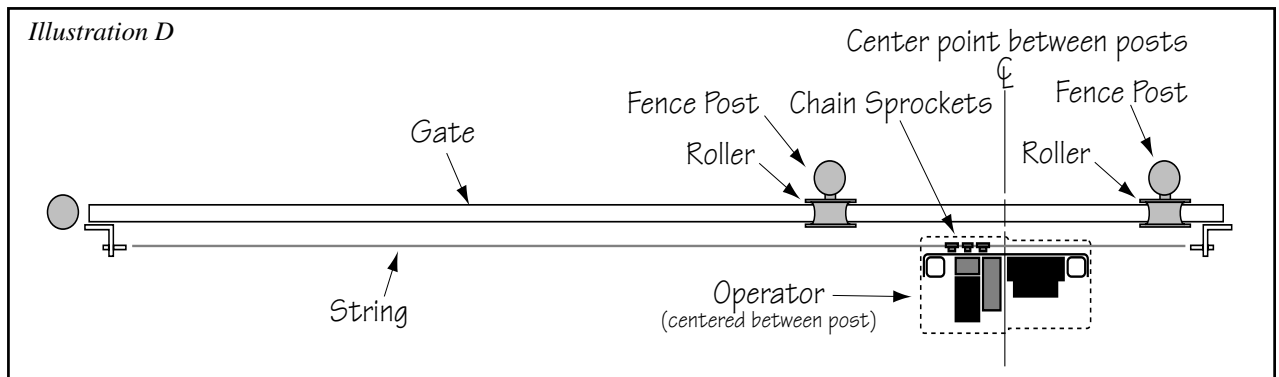

STEP 4

Find the center point between the two roller/fence posts (see *Illustration D*). This should coincide with the position of the center point of the operator. Dig a hole approximately 12" x 28" wide x 28" deep. Place the operator in the hole on its legs and position the bottom idler sprockets on the top of the string and level the unit (see *Illustration E*). Make sure operator is level and plumb. With the unit level and in place, pour the concrete and **let set for 24 hours** (checking the level periodically) **before proceeding to the next step.**

BEFORE POURING CONCRETE: 1] Make sure operator is centered between roller posts and aligned with string; and, 2] Determine method of installing conduit for wiring (see page 13)!

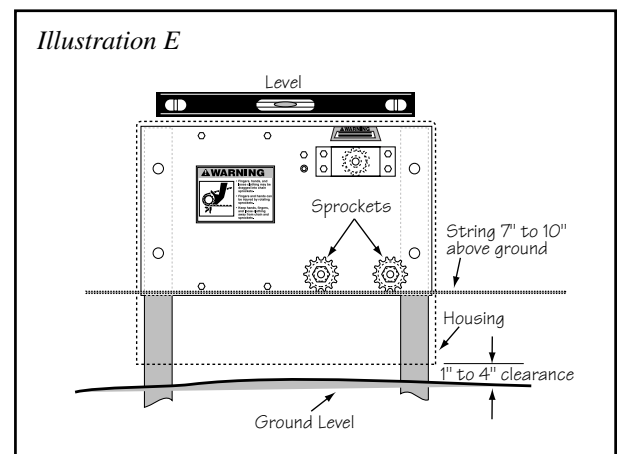

INSTALLING THE CHAIN

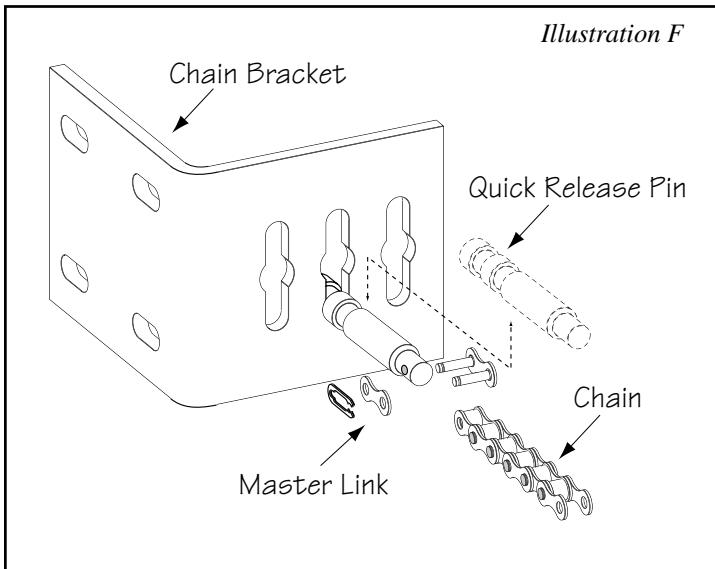

STEP 5

After the concrete has hardened, remove the string from the quick release pins. Attach the chain to one quick release pin with a master link (see *Illustration F*). Run the chain through the chain sprockets (see *Illustration G*).

STEP 6

Pull the chain to the second chain bracket leaving approximately four inches of slack (see *Illustration G*). **Do not pull chain tight**; a tight chain will interfere with the operation of the operator. Mark the chain where it meets the second quick release pin.

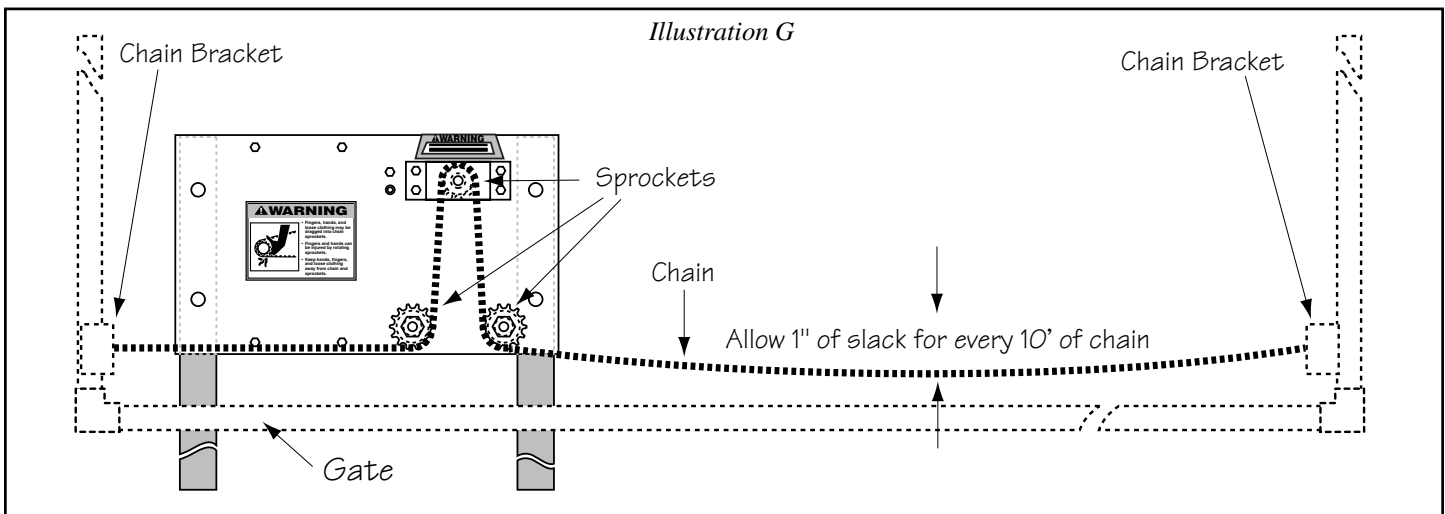

STEP 7

Drive the pin out of the chain link using a tool such as a punch or chain break. Connect the chain to the second quick release pin using a master link (see *Illustration H*).

TO OPEN THE GATE MANUALLY:

1. LIFT the quick release pins UP, then PULL them OUT of the chain brackets (see illustration).
2. Lay the chain down and manually slide the gate to the desired position.

To prevent unauthorized removal of the quick release pins, install pin locks (see *accessory catalog*) above the quick release pins in both chain brackets.

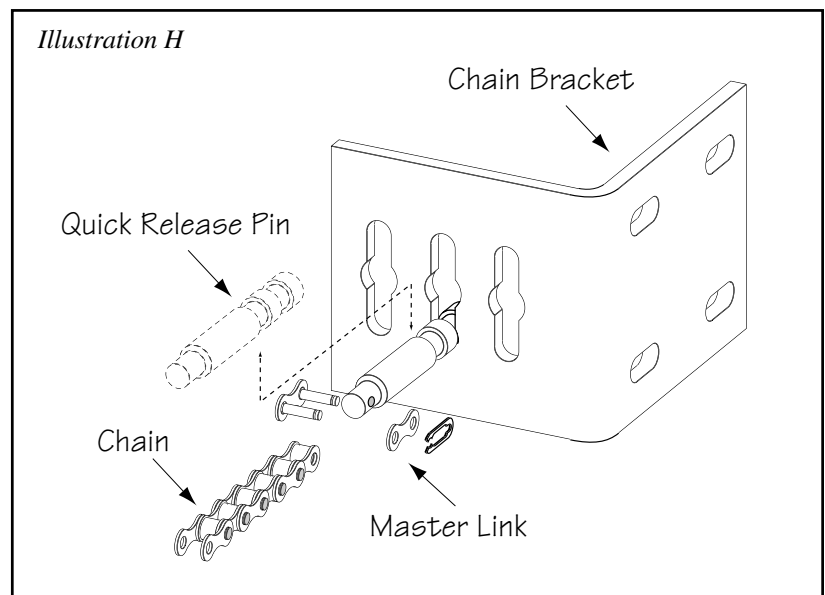

POWERING THE SYSTEM

CONNECTING THE BATTERY

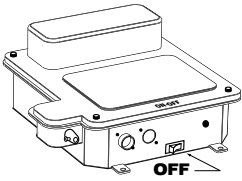

Make sure the control box power switch is in the OFF position.

STEP 8

Unscrew and remove the front cover of the control box and slide battery into position with its terminals to the left (*see illustration*). Make sure the battery fits snugly in control box.

Connect the **black** battery lead to the **negative (-)** terminal, and the **red** battery lead to the **positive (+)** terminal. **DO NOT** allow battery leads to touch the control board! Touching the control board with battery leads can short circuit the system!

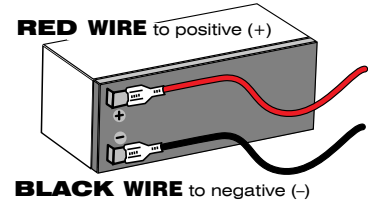

HINT: a dab of household petroleum jelly on each terminal will help prevent corrosion.

INSTALLATION OF THE GTO TRANSFORMER

Choose the electrical outlet into which the transformer will be plugged. Measure the distance from the electrical outlet to the control box, following the path where the low voltage wire will run (**the maximum distance can be no more than 1000 ft.**).

NOTE: Transformer must be connected with no more than 1000 ft. of 16 gauge multi-stranded, dual conductor, direct burial low voltage wire.

Predicting the exact maximum number of operational cycles at peak load is more of an art form than an exact science. The charts below illustrate the average maximum number of cycles (the “MNC”) in a 24 hour period on a typical single gate, and is installed such that the motor draws 10 amperes to move the gate.

| Gate Capacity Chart for SL-1000 Series <i>(estimated number of cycles based on use with a transformer)</i> | | | | | |
|--|--------|---------|---------|---------|---------|
| Gate Opening | 20 ft. | 120 | 110 | 100 | 90 |
| | 16 ft. | 140 | 130 | 120 | 110 |
| | 12 ft. | 160 | 150 | 140 | 130 |
| | 8 ft. | 180 | 170 | 160 | 150 |
| | | 200 lb. | 300 lb. | 400 lb. | 500 lb. |
| Gate Weight | | | | | |

| Gate Capacity Chart for SL-2000 Series <i>(estimated number of cycles based on use with a transformer)</i> | | | | | |
|--|--------|---------|---------|---------|----------|
| Gate Opening | 20 ft. | 80 | 70 | 60 | 50 |
| | 16 ft. | 100 | 90 | 80 | 70 |
| | 12 ft. | 120 | 110 | 100 | 90 |
| | 8 ft. | 140 | 130 | 120 | 110 |
| | | 400 lb. | 600 lb. | 800 lb. | 1000 lb. |
| Gate Weight | | | | | |

NOTE: Cycles shown are for single gate, dual gates will get approximately half as many cycles.

- 1) The MNC for the GTO/PRO SL-2000 is roughly comparable to most AC powered operators, and the transformer provided with this operator should handle most high traffic situations. If the battery does not seem to be able to provide the constant charge required for your application, the addition of the GTO/PRO 24 Amp Hour Battery Kit (see Accessory Catalog) should provide ample power to handle any situation. For more information, call GTO’s service department at 1-800-543-1236.

INSTALLATION OF THE GTO TRANSFORMER CONT.

- 2) If the gate is binding or dragging, or if ball bearing rollers are not used, it will require more than 10 amps to move it. This will reduce the MNC.
- 3) The charts are based on the transformer being plugged into an outlet that provides a line voltage of 120 volts; if the outlet provides less than 120 volts (for example, some rural areas may only provide 105 volts), it can reduce the MNC by as much as 50%.
- 4) A fully charged standard battery has an inherent reserve of 20-50 cycles without requiring a charge. This allows peak loads at several points during the day, depending upon how much time the transformer has to provide a charge to the battery between cycles. The transformer is capable of fully recharging the battery in as little as five minutes at optimum conditions.
- 5) The charts on page 16 are based upon an ambient temperature of 40° F. Battery performance and speed at which it will recharge will fluctuate based upon temperature.
- 6) The MNC for dual gate applications will be about 50% less of those for a single gate.

IMPORTANT:

- The GTO transformer is intended **for indoor use**. If the transformer can only be plugged into an outside electrical outlet, a weatherproof housing or cover (available at electrical supply stores) **must** be used.
- Use of a surge protector is highly recommended.
- Optional **Solar Panels** are available from a GTO dealer; see Accessory Catalog.
- **The GTO/PRO 24 Amp Hour Battery Kit is required for the SL-2000 in solar applications**, see Accessory Catalog.

NOTE: If your are considering using the GTO solar panel to maintain the system battery charge, please see the following chart:

SOLAR ZONES AND GATE ACTIVITY

This table and map illustrates the maximum number of cycles per day to be expected in a particular area, using either one or two of GTO's 10 watt solar panels (see *Accessory Catalog*). Figures are shown for **winter** (minimum sunlight) and do not account for use of any accessory items.

NOTE: Accessories will draw additional power from the battery.

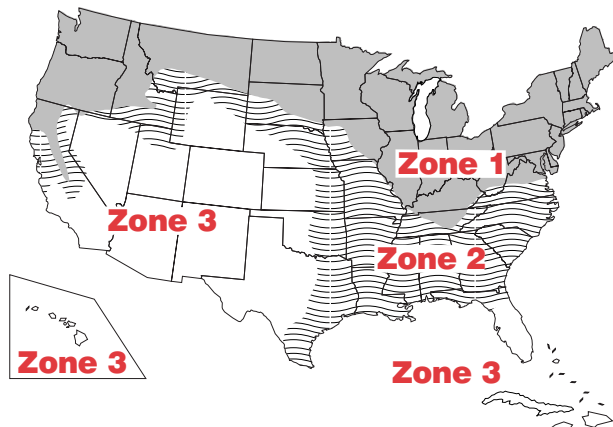

Estimated Maximum Number of Cycles Per Day

| Winter Ratings | Watts | Zone 1 | Zone 2 | Zone 3 |
|-------------------------------------|-------|--------|--------|--------|
| SL1000 | 10 | 4 | 8 | 13 |
| SL1000 | 15 | 6 | 12 | 20 |
| SL1000 | 20 | 8 | 16 | 26 |
| Dual SL1000 | 15 | 3 | 6 | 10 |
| Dual SL1000 | 20 | 4 | 8 | 13 |
| <i>Requires 24 Amp Hour Battery</i> | | | | |
| SL2000 | 10 | 4 | 8 | 13 |
| SL2000 | 15 | 6 | 12 | 20 |
| SL2000 | 20 | 8 | 16 | 26 |
| Dual SL2000 | 15 | 3 | 6 | 10 |
| Dual SL2000 | 20 | 4 | 8 | 13 |

STEP 9

Run the low voltage wire from the electrical outlet to the control box. **Do not exceed 1000'**.

NOTE: Pull approximately 1 foot of extra low voltage wire into the control box to accommodate terminal connections. To maintain adequate charging power, use *appropriate gauge, stranded, direct burial wire* (see *Accessory Catalog*). **Do not use telephone wire or any solid core wire because it will not provide adequate current. Never splice wires together.**

INSTALLATION OF THE GTO TRANSFORMER CONT.

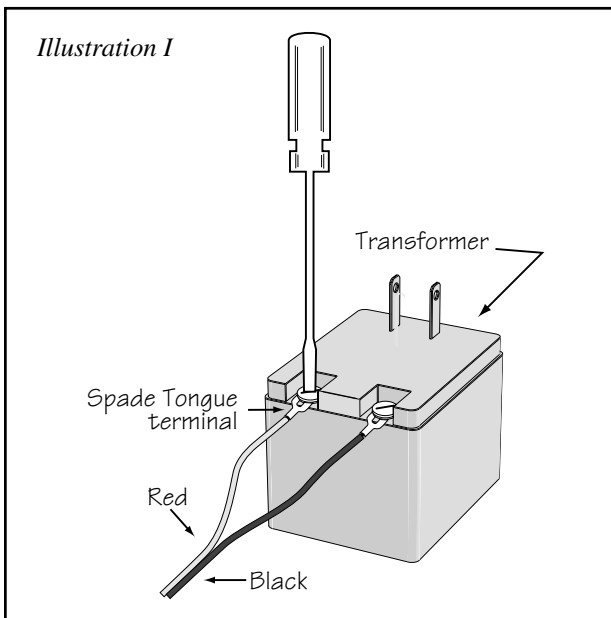

STEP 10:

Strip $\frac{3}{16}$ " off the ends of the low voltage wire and attach ends to the transformer terminals; **red wire to [RED], black wire to [BLK]**, (see *Illustration I*). A dab of household petroleum jelly on each terminal will help prevent corrosion.

We recommend crimping a spade-tongue terminal (*not provided*) to the end of each wire before attaching it to the transformer.

To prevent damage to transformer, make sure the exposed wire ends do not touch each other!

**DO NOT plug the transformer into outlet.
The transformer will be plugged in during STEP 13.**

NOTE: Wires coming from the ground to the control box should be run through PVC conduit to protect them from lawn mowers, weed eaters and grazing animals (see *illustrations on page 13*).

STEP 11:

Feed the low voltage wires upward through the strain relief on the bottom of the control box (see *Illustration J*). Pull 6" to 8" of wire into the control box.

If accessories (i.e. safety loops, card readers, etc.) are to be added during this installation, do not tighten the strain relief screw against the wires until the accessories have been connected. When all accessories have been connected, fully tighten the strain relief screw against the wires.

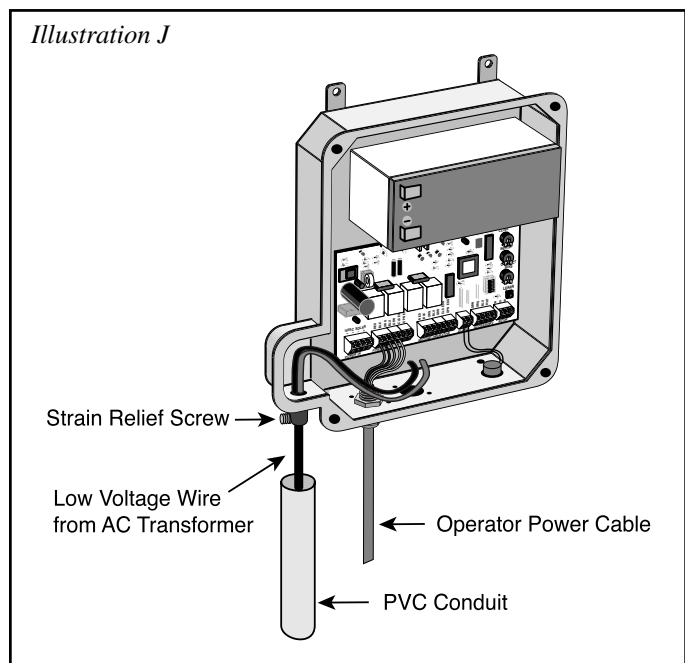

INSTALLATION OF THE GTO TRANSFORMER CONT.

STEP 12:

Strip $\frac{3}{16}$ " off the ends of the low voltage wire and twist tightly. These wire ends will be attached to the control board at the **18VAC** terminals located on the **POWER IN** terminal block (see *Illustration L*). Wire sheathing should not come in contact with terminals, however, it should not be stripped so far that wires can come in contact with one another (see *Illustration K*).

Insert one transformer wire into an **18VAC** terminal. Insert the other transformer wire into the remaining **18VAC** terminal (see *illustration L*). Transformer wires can be connected to the **18VAC** terminals regardless of color.

Tighten set screws against exposed end of wires (see *Illustration K*). A dab of household petroleum jelly on each wire end will help prevent corrosion.

The **ACCESSORY** terminal block provides the connection point for safety loops, wands, push buttons, intercoms, card readers, etc. See page 27 for more information about connecting accessories.

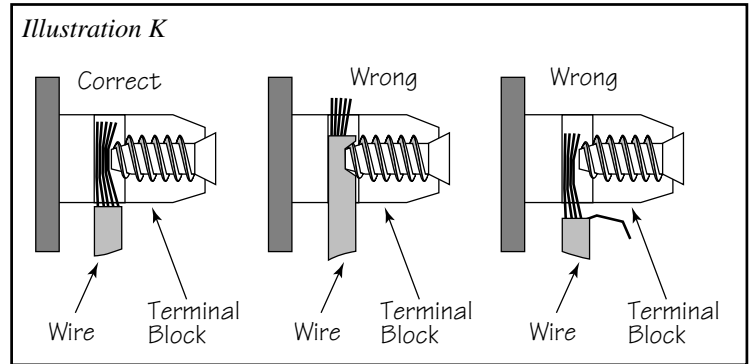
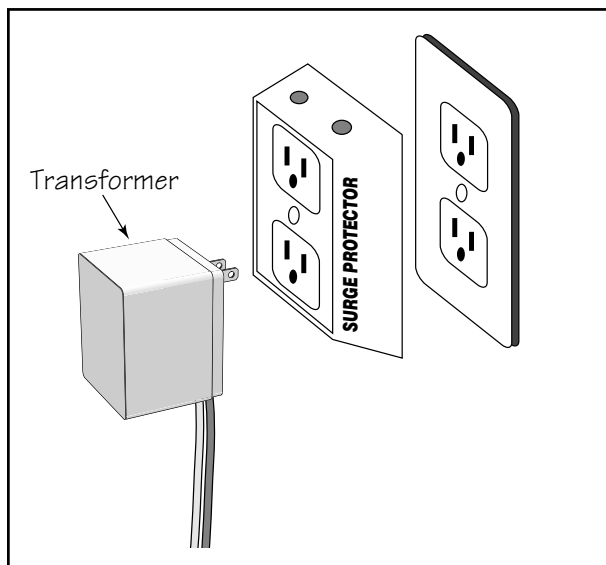
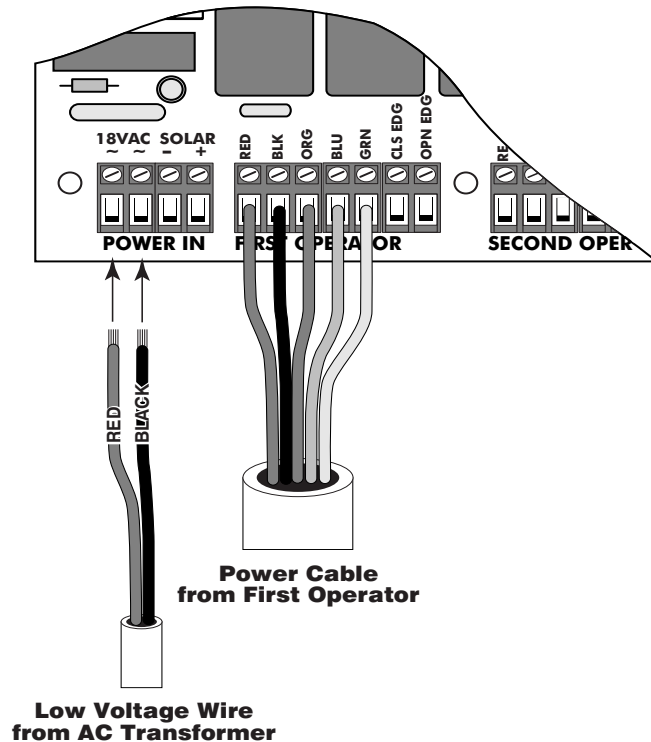

Illustration L



HINT: Keep a few mothballs in the control box to discourage insects from entering it and damaging the control board.

STEP 13:

Plug the transformer into the electrical outlet. Check to see if the green LED on the control board is on. If it is not, see the **Troubleshooting Guide** on page 30.

NOTE: Use of a surge protector is strongly recommended.

CONTROL BOARD SETTINGS

DIP SWITCHES

The four DIP switches on the control board match the operator with the type of gate on which it is mounted. For example, gates may open right to left or left to right. Prior to packaging, the GTO/PRO SL-1000 and SL-2000 series control board was configured for a single slide gate that opens **right to left**. If your gate type matches this configuration, you **DO NOT** need to adjust the DIP switches. Proceed to the **Potentiometers** section on the next page. **NOTE:** *The direction a gate opens is determined by standing inside the property and facing toward the gate.*

NOTE: *To change the DIP switch settings, you must turn the control box power switch OFF; move the switch; then turn the power back ON. Use a small screwdriver to move the switches.*

PULL/PUSH: Set to **PULL** for slide gates that open **RIGHT** to **LEFT** [factory setting]; **PUSH** for slide gates that open **LEFT** to **RIGHT**.

SNGL/DUAL: Set to **SNGL** for a single gate leaf [factory setting]; **DUAL** for dual gate leaves.

SEQ1: Controls the opening order of dual gate leaves. See **Setting the Control Board for Dual Gate Operator Installation** on page 37 for more information. (the factory setting is OFF).

SEQ2: Controls the opening order of dual gate leaves. See **Setting the Control Board for Dual Gate Operator Installation** on page 37 for more information (the factory setting is OFF).

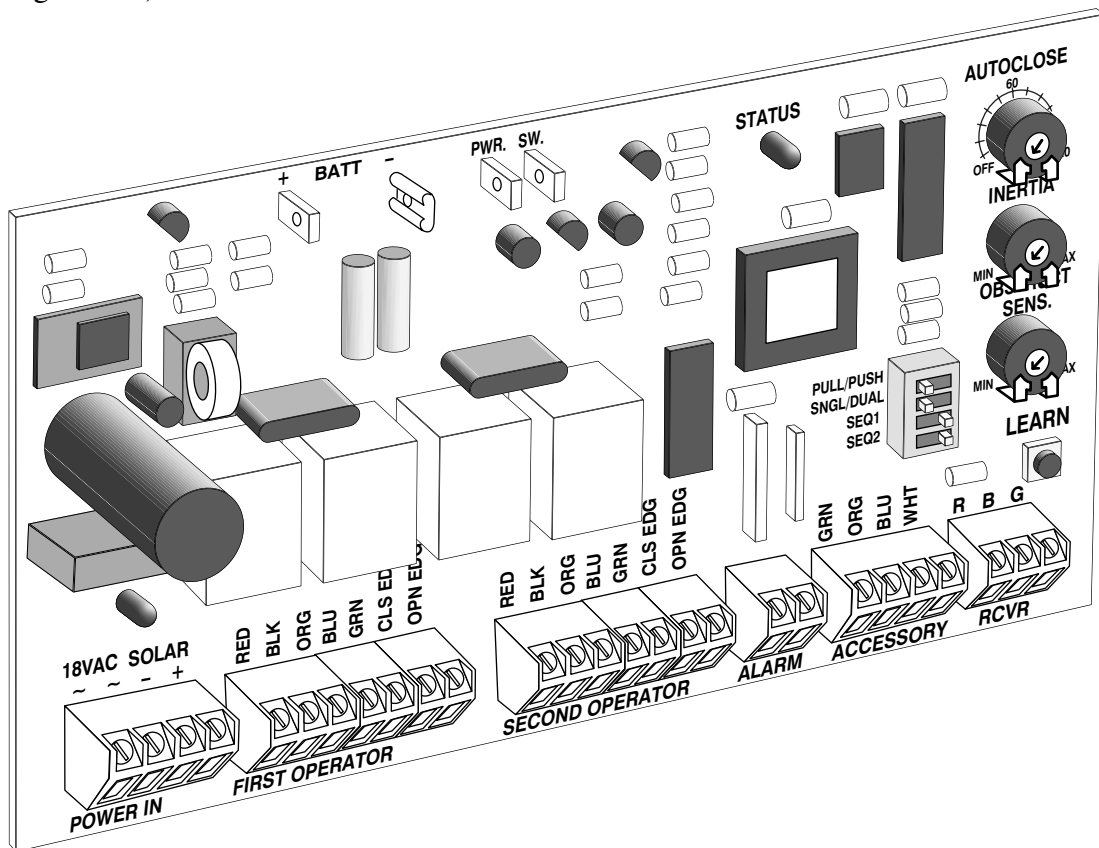
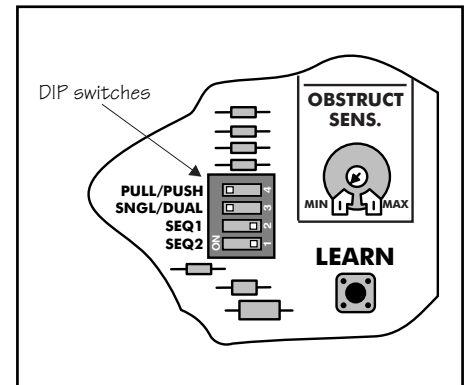

POTENTIOMETERS

The three (3) potentiometers on the control board operate like a volume control on a radio. They control the auto close timer, inertia, and obstruction sensitivity of the operator. Use a small slotted screwdriver to turn the arrow in the center of the potentiometer. Clockwise rotation increases the setting (**MAX**). Counterclockwise rotation decreases the setting (**MIN**).

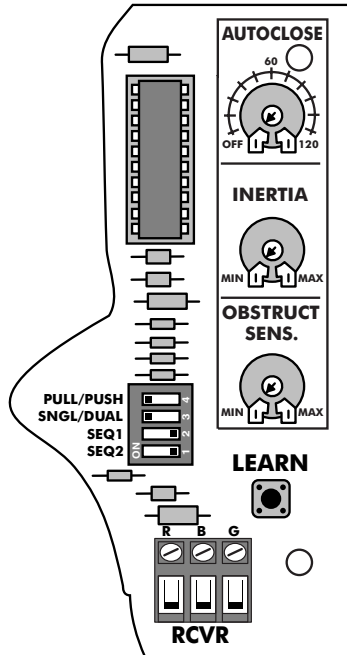

AUTO CLOSE (auto close timer): Determines how long the gate will remain open before it automatically closes. The limits are **OFF** to 120 seconds. The factory setting is **OFF**.

INERTIA: Fine tunes obstruction sensitivity in the opening and closing modes. **INERTIA** allows the operator to attempt to push an obstruction clear of the gate path. When **INERTIA** is set to **MIN** the operator will obstruct *quickly* (i.e., will attempt to push an obstruction briefly); when set to **MAX** the operator will obstruct *slowly* (i.e., will push against an obstruct for a longer period). The factory setting is **MIN**.

OBSTRUCT SENS. (obstruction sensitivity): Determines the amount of *force exerted by the gate* on an obstruction before the operator stops and reverses. The gate will exert *minimum force* before obstructing when set to **MIN**. When set to **MAX**, the operator will exert *maximum gate force* before obstructing (i.e., the operator will require greater resistance before stopping and reversing.). The factory setting is **MIN**.

READ WARNING BELOW!

NOTE: Heavy gates and gates with high wind resistance *may* require the **OBSTRUCT SENS.** potentiometer to be set closer to **MAX** to prevent the operator from obstructing. Keep in mind, however, that while you must determine the best setting for *smooth* gate operation, you must ALSO determine the lowest possible setting for *safe* gate operation.

ALWAYS KEEP SAFETY AT THE TOP OF YOUR LIST WHEN ADJUSTING OR SERVICING YOUR AUTOMATIC GATE OPERATOR!



All three potentiometers were set to minimum at the factory. The **OBSTRUCT SENS.** potentiometer **MUST** be adjusted above the factory setting for your **GTO/PRO SL-1000** or **SL-2000** operator to function properly. If the potentiometer is left at **MIN**, your gate operator may "obstruct" (i.e., stop and reverse) as soon as it is activated.

BE SURE TO PROPERLY RETEST THE GATE OPERATOR AFTER MAKING ANY ADJUSTMENTS; FAILURE TO DO SO MAY RESULT IN SERIOUS INJURY OR DEATH.

SETTING THE PERSONAL TRANSMITTER CODE

All GTO transmitters are set to a standard code at the factory and are ready to activate the automatic gate operator. For safety and security, however, we **strongly recommend** that the factory setting be replaced with a personal code. Follow the directions below:

1. REMOVE THE TRANSMITTER COVER

Grasp the sides of the access cover and slide it away from the transmitter button (see illustration). When the access cover is removed, the battery and the DIP switches will be exposed. To set a new code, use a small screwdriver to move the switches.

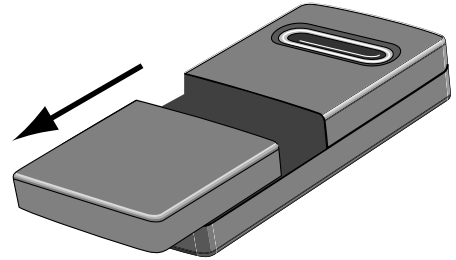

2. SET THE TRANSMITTER DIP SWITCHES

There are nine (9) transmitter DIP switches; each of which can be placed in three different positions (+, 0, -). **DO NOT** set all the switches in the same position, such as all +, all 0, or all -. Once the DIP switches have been set to a personal code, replace and close the access cover.

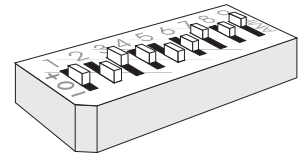

WARNING: No other adjustments should be made inside the transmitter.

3. "TEACH" THE NEW CODE TO CONTROL BOARD MEMORY

- A. Turn control box power switch **OFF**.
- B. Unscrew and remove the control box cover.
- C. Press and hold the **LEARN** button on the control board, and turn the power switch **ON**. Release **LEARN** button. Wait 15 seconds for the receiver to charge.
- D. Press and hold transmitter button until the red **STATUS** LED comes **ON**.
- E. Release transmitter button. The new code is stored in the control board memory.

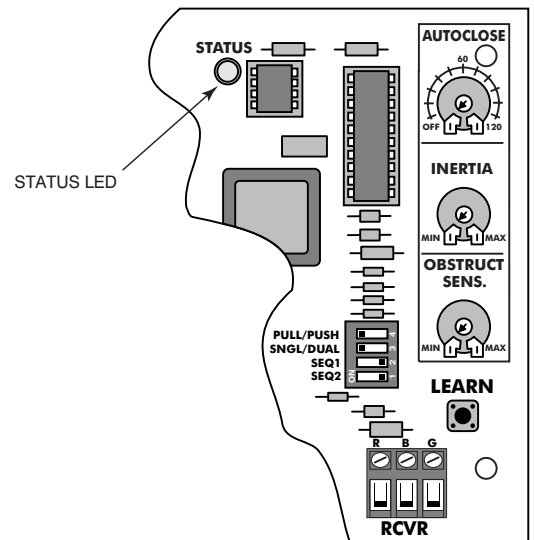

Replace the control box cover and turn the power switch to the ON position.

MOUNTING THE RECEIVER

Use the transmitter to check the range of the receiver before permanently mounting it.

Consider the following when mounting the receiver:

- Receiver cable length is 20 feet (receivers with a longer cable are available as special order items; *Call the GTO Sales Department*). NEVER splice receiver cable!
- **Run the cable through PVC conduit to protect it from damage.**
- DO NOT run cable through metal conduit because the receiver signal range will be decreased.
- DO NOT run cable in a conduit containing AC wiring.
- DO NOT mount receiver on a metal fence or post; doing so will decrease signal range.
- DO NOT overtighten the mounting screws.
- The receiver range can vary from 50 to 100 feet depending upon weather, topography, and external interference.

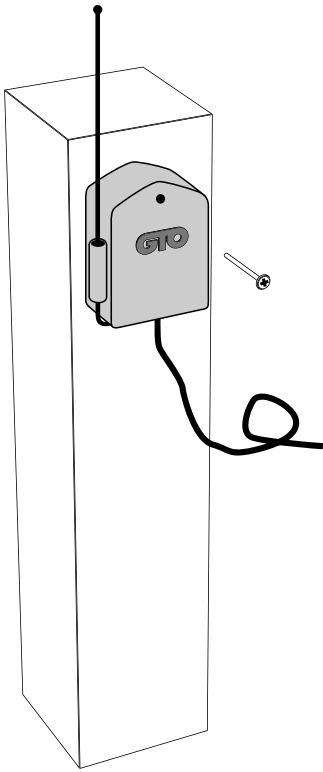

FCC Regulation

This device complies with FCC rules Part 15. Operation is subject to the following conditions:

1. This device may not cause harmful interference.
2. This device must accept an interference that may cause undesired operation.

Transmitter distance may vary due to circumstances beyond our control. **NOTE: The manufacturer is not responsible for any radio or TV interference caused by unauthorized modifications to this equipment. Such modifications could void the user's authority to operate the equipment.**

ADJUSTING THE LIMIT SWITCHES

After the operator is installed, adjust the open and closed position limit switches as needed. The limit switches determine how far the gate travels to open and to close.

Adjust the limit switches using the limit nuts. Lift limit switch plate to adjust limit nuts (see *Illustration M*).

The open and closed position switches will be reversed depending on whether the gate opens from left to right or from right to left (see *Illustration N*).

⚠ WARNING! In order to adjust switches, the control box must be **ON**. **USE EXTREME CAUTION** when adjusting limit switches to prevent fingers, hair, clothing, etc., from getting caught under the limit switch plate and possibly causing bodily injury.

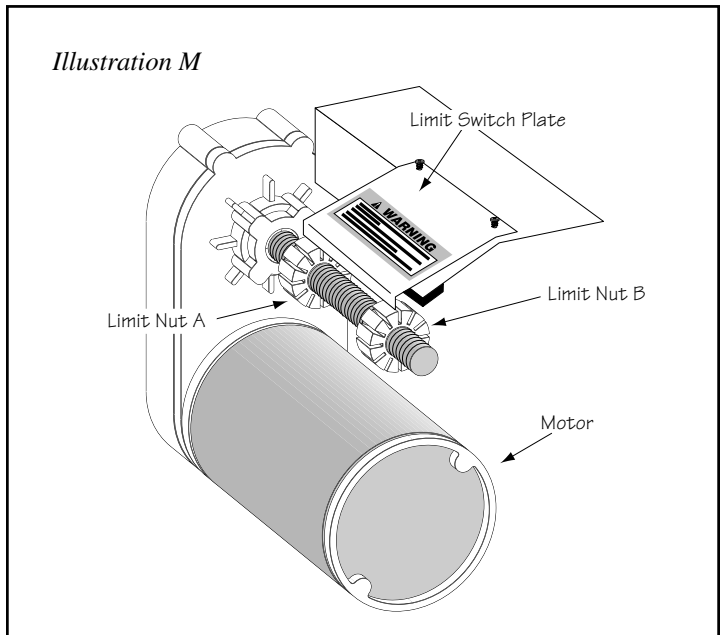

If your gate opens from Right to Left:

1. Gate Opening: For gate to open further, turn Limit Nut A counterclockwise. For gate to open less, turn Limit Nut A clockwise.
2. Gate Closing: For gate to close further, turn Limit Nut B counterclockwise. For gate to close less, turn Limit Nut B clockwise.

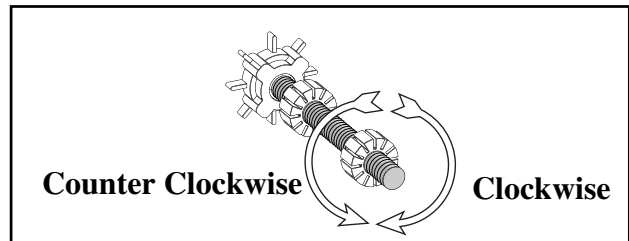

However, if your gate opens from Left to Right:

1. Gate Opening: For gate to open further, turn Limit Nut B counterclockwise. For gate to open less, turn Limit Nut B clockwise.
2. Gate Closing: For gate to close further, turn Limit Nut A counterclockwise. For gate to close less, turn Limit Nut A clockwise.

Once the limit switches are adjusted, make sure the limit switch plate rests in the grooves on both limit nuts.

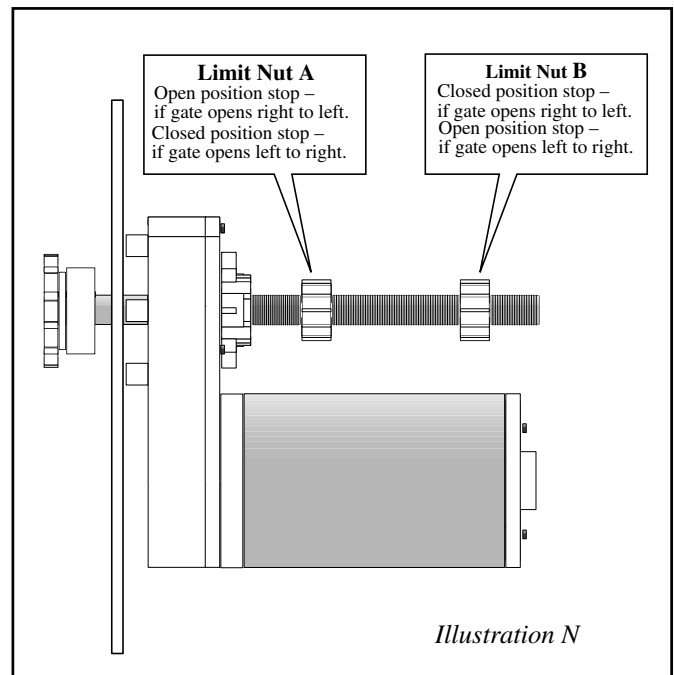

CONNECTING SAFETY DEVICES

The GTO/PRO SL-1000 and SL-2000 series operators are equipped with built-in obstruction sensitivity. These operators are designed to stop and reverse the gate for 2 seconds when it comes in contact with an obstruction. However, obstruction sensitivity, even when properly adjusted, *may not be sensitive enough to prevent bodily injury*. For this reason, *safety edges or photoelectric sensors MUST be installed on the gate*. Safety edges (or photoelectric sensors) must be mounted in compliance with Underwriters Laboratories' safety standard for gate operators, UL 325. Review page 6 for information about mounting requirements for safety edges and photoelectric sensors.

Refer to the sensor manufacturer's instructions for information about installing these devices on a vehicular gate.

⚠ Make sure the control box power switch is OFF before connecting safety device wiring to the terminal blocks.

Insert the safety device wires into the **CLS EDG** terminal (located on the **FIRST OPERATOR** terminal block) for the gate closing mode. Ground the safety device at the **GRN** terminal. Connect the safety device wires for the gate opening mode to the **OPN EDG** terminal in the same manner.

⚠ MAKE SURE TO GROUND THE SAFETY DEVICES AT THE GRN TERMINAL! THE CONTROL BOARD COULD BE DAMAGED IF THE SAFETY DEVICES ARE NOT GROUNDED!

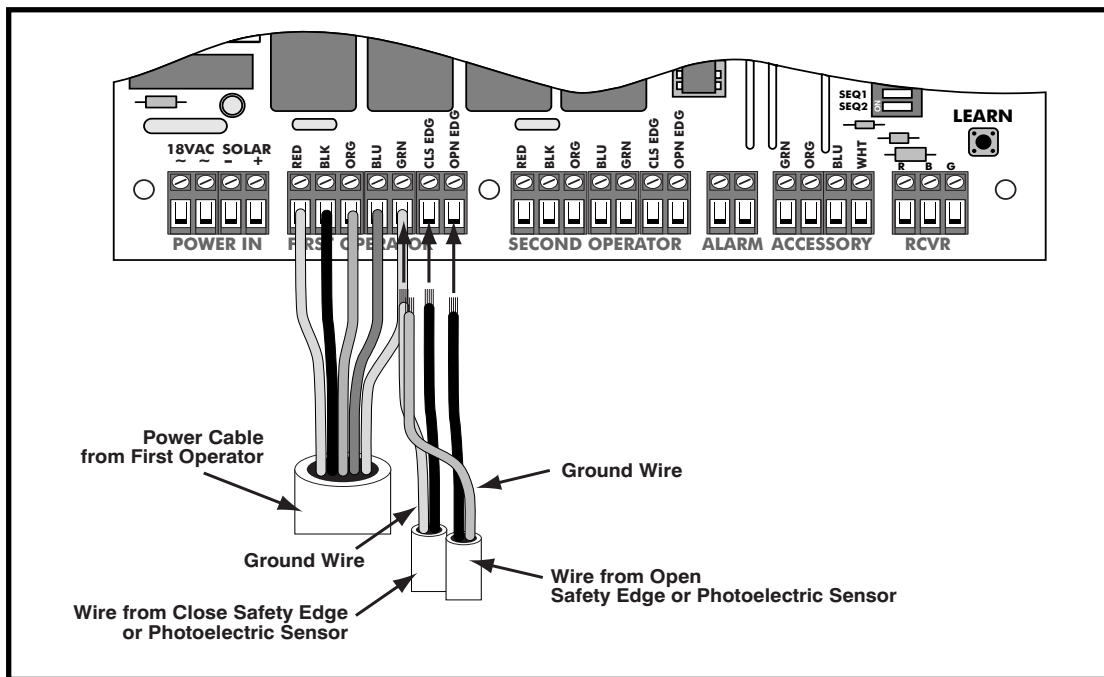

CONNECTING ADDITIONAL SAFETY DEVICES

Although GTO **strongly recommends** the use of additional safety devices, we do not endorse any specific brand names. Only use products that are certified and listed to be in compliance with UL (United Laboratories) and national and regional safety codes.

Call GTO Sales at 1-800-543-4283 for information on compatible products for your specific application.

CONNECTING ACCESSORIES

Make sure the control box power switch is OFF before connecting accessories.

The **ACCESSORY** terminal block is the connection point for accessories such as push buttons, safety loops, intercoms, etc. The **ACCESSORY** terminal marked **GRN** (green) is the common ground for all accessories. **GRN** is paired with the terminals shown below when connecting accessories to the control board.

IMPORTANT: Make sure to twist exposed wires tightly and insert them into the terminals without loose strands. Tighten set screws against exposed end of wires. A dab of household petroleum jelly in each terminal will help prevent corrosion.

WHT (WHITE) USED WITH GRN (GREEN):

This is the most frequently used pairing for a doorbell button, keypad, or keyswitch. Accepts input from or is used with N/O contact devices.

- First contact will start the gate.
- Second contact will stop the gate.
- Third contact will reverse the gate.

NOTE: Never use a lighted doorbell button!

It will discharge the battery and the gate operator will fail to operate.

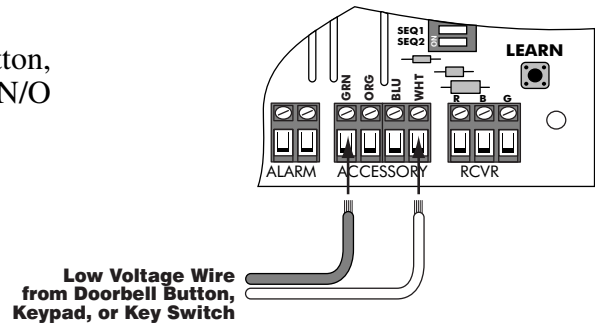

BLU (BLUE) USED WITH GRN (GREEN):

This pairing is typically used for a free exit or free entry devices. Accepts input from or is used with N/O contact devices

First contact will open the gate.

NOTE: If the gate is in the open position and begins to close, the activation of the accessory device will reopen the gate. In communities where the use of an emergency entry device is mandatory, it should be connected to these terminals.

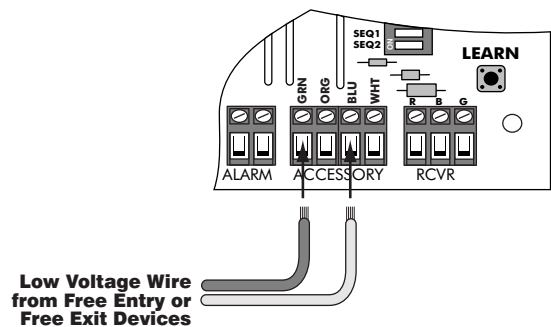

ORG (ORANGE) USED WITH GRN (GREEN):

This pairing is frequently used for safety loops. Accepts input from or is used with N/O contact devices.

This connection will not open your gate. The safety loop will activate *only while the gate is in use*. When using this combination, the gate will remain open or reopen if it is closing.

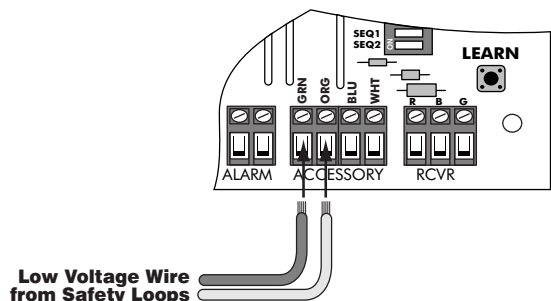

ATTACHING THE HOUSING

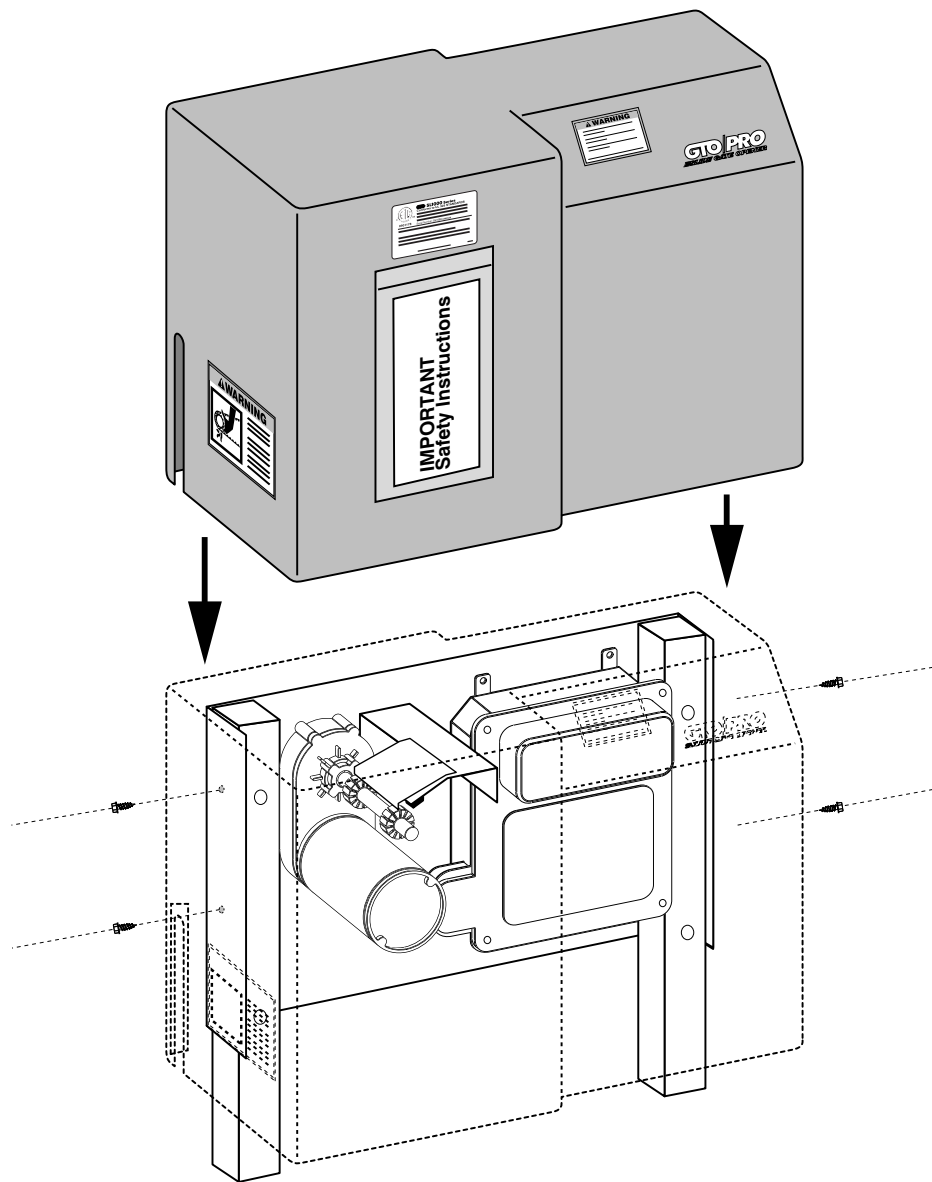

Mount the operator housing after all installation procedures are complete. Slide operator housing over legs, align holes, and use screws provided to attach housing to operator.

IMPORTANT: Hang the two (2) GTO Warning Signs (provided) on both sides of the gate before operating. **Make sure** all warning signs and labels are in place. **Make sure** that the packet containing end user safety instructions and warranty procedures remains attached to the operator housing (as shown in the illustration).

Review the safety precautions & operator warranty procedures contained in packet (attached to the operator housing) with the customer. Leave packet attached to the housing for future reference.

MAINTENANCE

The **GTO Slide Gate** Operator is designed for minimum maintenance. However, for optimum performance and safety, the following maintenance procedures should be taken:

GATE

Having a well maintained gate will ensure that the operator runs smoothly and safely. Make sure gate is hung level and plumb. Check and adjust periodically. Lubricate rollers periodically with grease appropriate for the coldest weather in your area.

SAFETY EDGES

Periodically test the safety edges to make sure they are functioning correctly. If they are not, discard and replace immediately.

CONTROL DEVICES

From time to time, check to ensure that all of the control devices connected to the operator are functioning. **This is especially important for safety devices.**

OPERATOR

Occasionally inspect the chain to ensure that it is well lubricated, and oil the chain as necessary. Use **CHAIN AND CABLE LUBE** for best results. Check the gear sprockets and grease them as needed. Check the rollers and spray oil on them as needed.

TROUBLE SHOOTING GUIDE

Maintenance:

- On all gates weighing 250 lb. or more, routinely grease the ball bearing rollers at least 4 times a year; grease more frequently if the gates are near a coastal area.
- Keep a few mothballs in the control box to discourage insects from entering it and damaging the control board.
- Have your gate operator tested monthly and serviced regularly by an experienced technician. The gate **MUST** stop and reverse on contact with an obstruction or when an object activates the non-contact sensors. If these functions are observed to operate improperly, discontinue use and have operator serviced immediately.

The operator has a 12 Vdc motor with mechanical limit switches.

- **To test the motor**, put a voltmeter on DC and place the meter leads on the wire connections inside the plastic cover above the switches. The reading should be at least 11.5 V when the system is active. If it is not, see *The Control Board* section
- **To test the switches**, put the meter on “ohms.” Place the leads on each of the wires on the switch. You should have an open circuit. Click the switch and you should have .2 ohms. Do this for both switches.
- **To test the cable**, put the meter on ohms. At one end of the cable place the lead on the green wire, and on the other end of the cable place the lead on the green wire and the other wires. This should show a maximum of 1.0 ohms on the green wire and nothing on the other wires. Test each wire as you have above. If all have the proper readings, then this is not the problem.
- **Note:** Inspect the cable for any signs of any punctures because wires inside the PVC jacket can be shorted and the cable will still show proper ohms.

The control board: This is a micro processor board. The power that runs the gate is from the battery and recharged, through the board only, by a 18 volt 40 VA. (2.9 A) transformer.

There is one (1) green and one (1) red LED (light emitting diode) on the control board. They are for a quick reference only. All readings must be measured by a voltmeter!

The red light serves two purposes. The first is to aid in storing the personal transmitter code. See “Setting the Personal Transmitter Code”.

The second is to show the condition of the battery. If it is flashing, see the following section on “Testing the battery.” The normal state of this light is on, but dim.

If the red LED is flashing it means that the system may have reached low voltage lockout; the unit does not have enough voltage to operate the system. One of the following problems may exist:

- Broken or spliced wires from the transformer or solar panel to the control board.
- A transformer or solar panel that has no output voltage.
- Incorrect number of solar panels, or solar panels not properly hooked up.

The green light serves as a quick visual indication that the control board is receiving power from the transformer.

The transformer: Two things can cause failure: the first is shorting the leads during the installation, or letting the strands touch at the terminal on the control board. The second is a static charge (generally associated with a lightning storm or power outage); use of a surge protector will help.

Testing the battery: This is a 12 volt 7 Ah battery. The proper way to test this is to perform a load test. Place the voltmeter on D.C.; put the red probe on the (+) positive terminal and place the black probe on (-) negative terminal. Then activate the unit and watch the voltmeter. The drop should not be more than 1 volt.

Note: A loose battery terminal will cause the same symptoms that a bad battery will cause. Terminals should be secure and corrosion free.

Remote control range: This will vary at each installation. (see FCC disclaimer on page 23), but generally varies from 50 ft. to 100 ft.

- Make sure that the receiver is located above metal fences.
- Moving the receiver even a few inches can change the range of operation.
- Move the receiver as far from the motor as possible to avoid the chance of electrical interference.
- Check or change the battery in the transmitter.

SYSTEM TEST SPECIFICATIONS

| | |
|-------------------|--|
| Transformer: | 120 Vac / 60 Hz input 18 Vac / 40 VA output |
| 10 W solar panel: | 18-22 Vdc / 600 mA per hour |
| Battery: | 12 Vdc / 7 Ah |
| Wire: | 16 gauge, multi stranded, direct burial |
| Motor: | 12 Vdc 90 rpm with case hardened gears. The motor current range is 2.5 to 10 A if the gate is in good working order. |
| Receiver: | 5 Vdc / digital communication. ONLY GTO receivers can be connected to these terminals. |
| Control board: | Microprocessor driven. Powered by 12 Vdc. |

**The GTO, Inc. Technical Service Department is open
Monday – Thursday 7:30 A.M. – 5:30 P.M.
and Friday 8:00 A.M. - 12:00 P.M. (Eastern Time)**

TELEPHONE (800) 543-1236 OR (850) 575-4144

FAX (850) 575-8950 • E-mail: techsupport@gtoinc.com • www.gtoinc.com

WARRANTY AND REPAIR SERVICE

If the GTO gate operator system is not operating properly and you have not been able to solve the problem, please follow the steps below:

1. Check the Trouble Shooting Guide (page 29).
2. Call your installer.
3. If you still cannot solve the problem, call the GTO Service Department at (850) 575-4144.
4. If repair or replacement is necessary, you will be assigned a Return Goods Authorization Number (RGA). Write the RGA # in **LARGE BOLD PRINT** on the outside of the package.
5. Carefully pack the component(s) authorized for return and ship freight prepaid to GTO, Inc., 3121 Hartsfield Road, Tallahassee, Florida, USA 32303.

NOTE: GTO products returned without a Return Goods Authorization Number (RGA) or returned freight collect WILL NOT be accepted at the factory. A copy of the owner's receipt with date of sale and installation must accompany warranty related request for service.

6. If the repair service or replacement is covered by the warranty, GTO, Inc. will pay shipping costs (equal to United Parcel Service ground rate) for return to owner of items repaired under warranty.

GTO/PRO[®] **AUTOMATIC GATE OPERATORS** **Limited Two Year Warranty**

GTO/PRO DC powered gate operators are warranted by the manufacturer against defects in materials and manufacturer workmanship for a period of two (2) years from date of purchase, provided recommended installation procedures have been followed.

In the case of product failure due to defective material or manufacturer workmanship within the two (2) year warranty period, the operator will be repaired or replaced (at the manufacturer's option) at no charge to the customer, if returned freight prepaid to GTO, Inc., 3121 Hartsfield Road, Tallahassee, Florida 32303. **IMPORTANT: Call (850)575-4144 or fax (850) 575-8950 for a Return Goods Authorization (RGA) number before returning to factory.** Products received at the factory without an RGA number will not be accepted. Replacement or repaired parts are covered by this warranty for the *remainder* of the two (2) year warranty period or six (6) months, whichever is greater. GTO will pay the shipping costs (equal to United Parcel Service ground rate) for return to the owner of items repaired under warranty.

The manufacturer will not be responsible for any charges or damages incurred in the removal of the defective parts for repair, or for the reinstallation of those parts after repair. This warranty shall be considered void if damage to the product(s) was due to improper installation or use, tampering, connection to an improper power source, or if damage was caused by lightning, wind, fire, flood, insects or other natural agent. This warranty gives you specific legal rights, and you may also have other rights which may vary from state to state. This warranty is in lieu of all other warranties, expressed or implied. **NOTE: Verification of the warranty period requires copies of receipts or other proof of purchase. Please retain these records.**

After the two (2) years warranty period, GTO or one of its authorized service centers will make any necessary repairs for a nominal fee. Call GTO at (850) 575-4144 for more information.

INSTRUCTIONS FOR THE INSTALLATION OF A DUAL SLIDE GATE SYSTEM

Use the SL-1200 with the SL-1000 and the SL-2200 with
the SL-2000 for dual slide gate systems.

GTO/PRO[®]
AUTOMATIC GATE OPERATORS

DUAL GATE SYSTEM INSTALLATION

Install the second gate operator in the same manner as the Single gate operator starting on page 14 of this manual. The second gate preparation and wiring of the second (auxiliary) operator follow on the next two pages. Once the second gate operator is installed, Set the DIP switches for DUAL gates and the order in which the gates open (“sequencing”). **Setting the Control Board for Dual Gate Installations begins on page 37.**

SECOND GATE (AUXILIARY) OPERATOR PARTS & HARDWARE

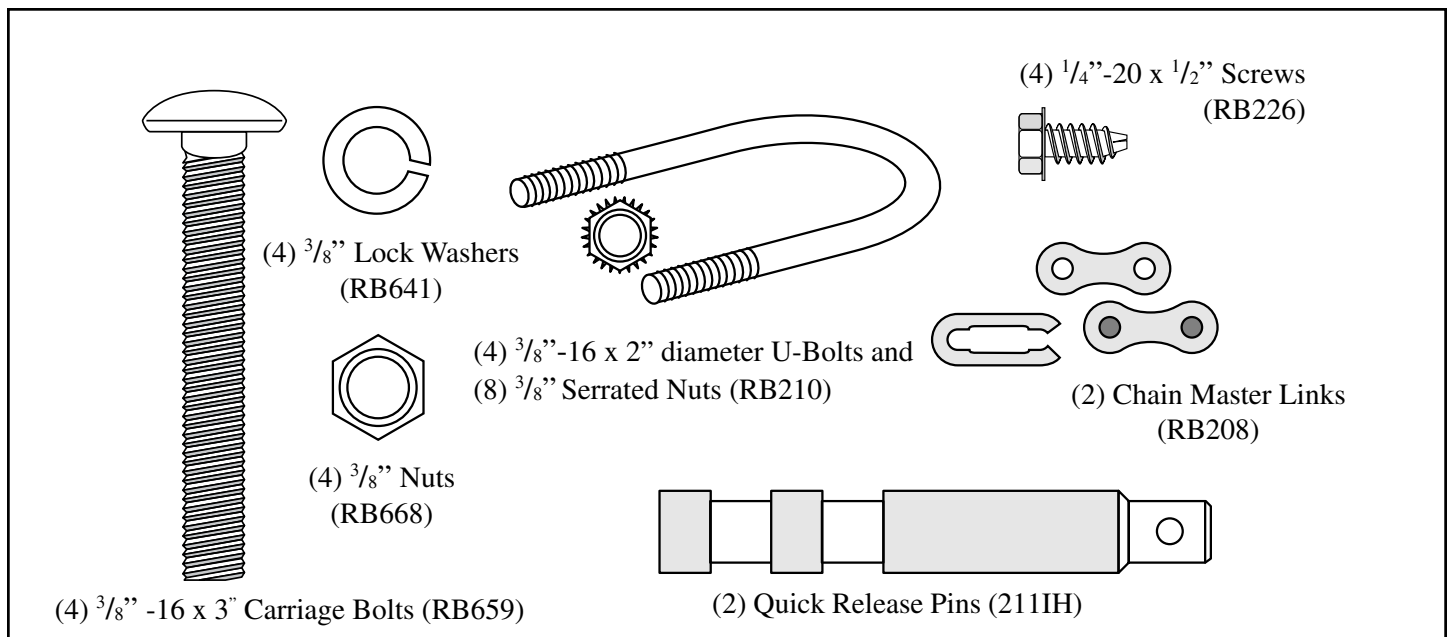
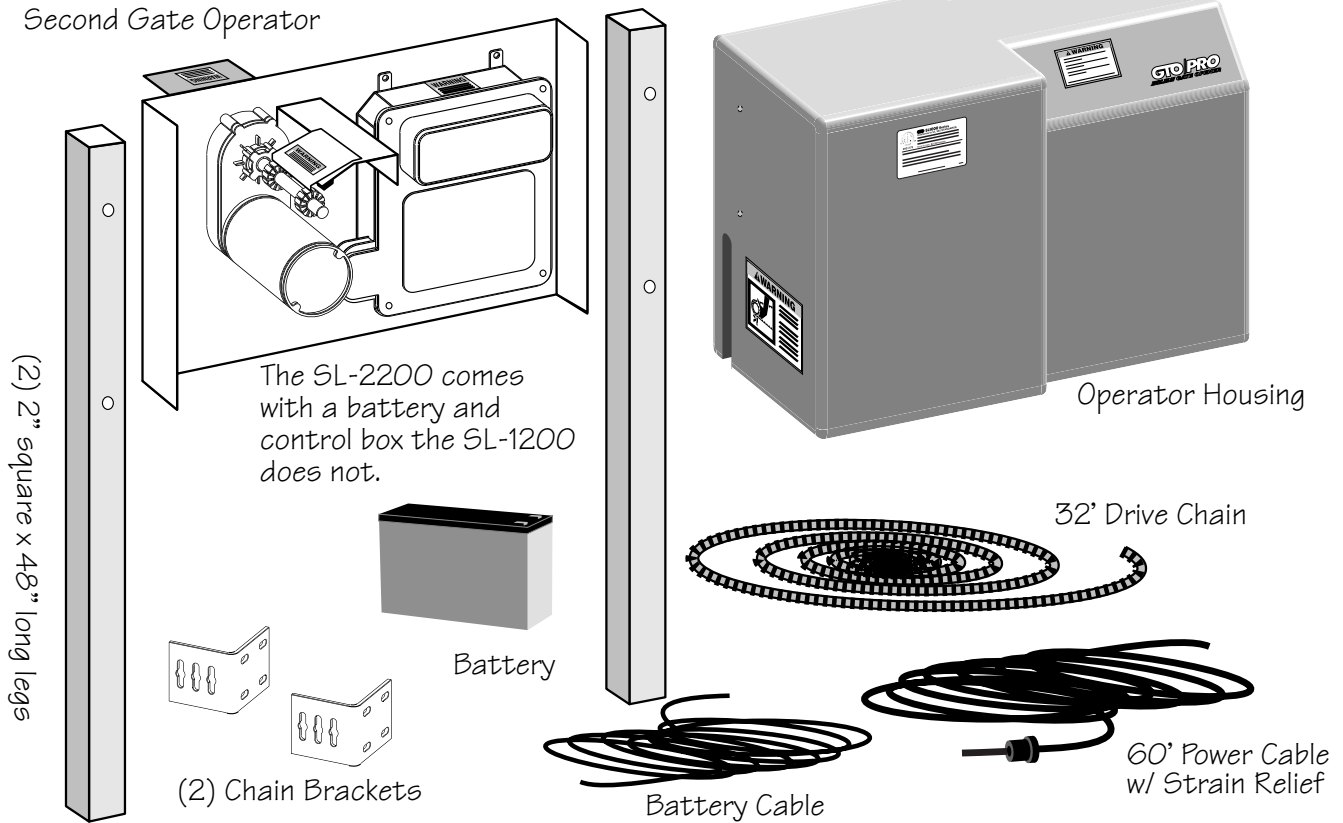

PREPARING THE GATES

Install PVC conduit (not included) needed for power cables and low voltage wiring – see illustration below. The PRO SL-1200 and SL-2200 power cable and safety edge (required) wiring should be run through PVC conduit underneath the driveway. If you cut the driveway be sure to reseal it after all wiring is installed.

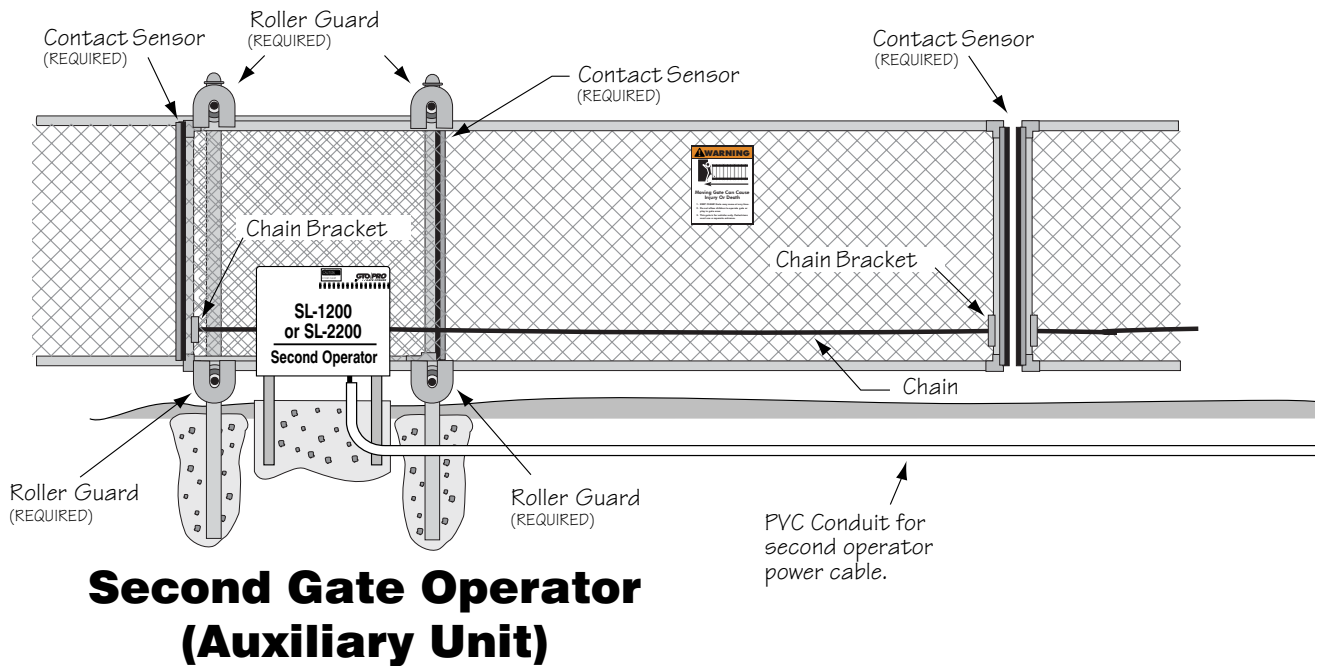
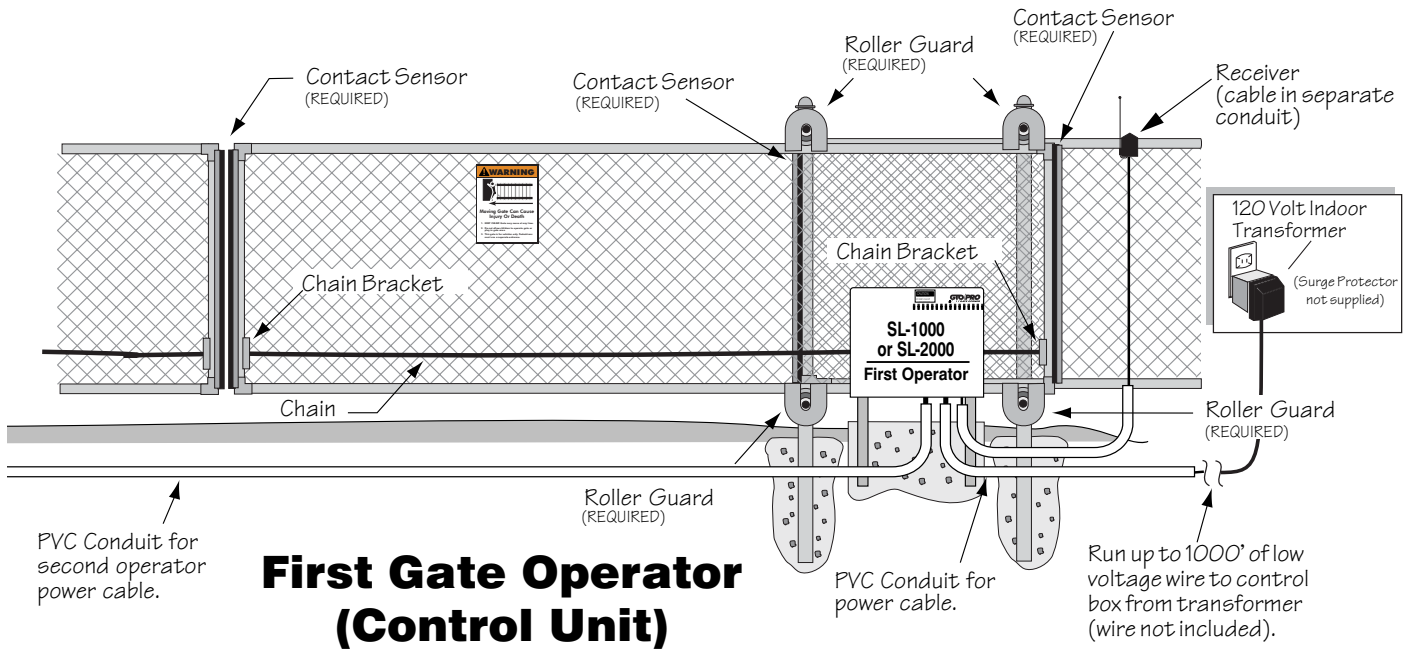

WIRING THE SECOND OPERATOR

When the units are set in place and you have completed wiring the first unit follow the instructions below.

Step 1: With the PRO SL-1000 or SL-2000 control box open, use a screw driver to punch out the round knockout hole located on the bottom next to the First Operator power cable. Install the strain relief for the Second Operator power cable. Leave about 6" of the power cable and tighten the strain relief nut to secure the wires.

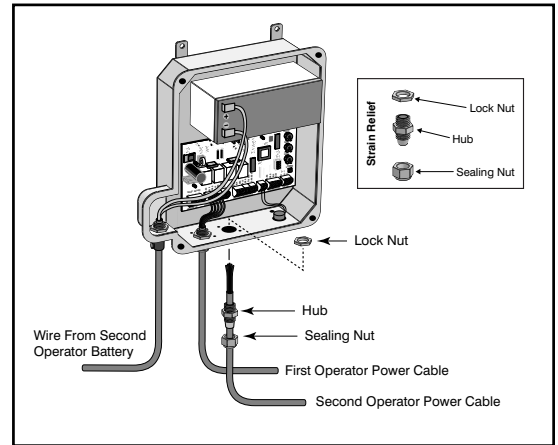

THIS STEP IS FOR SL-2000/2200 INSTALLATION ONLY

Step 1a: Run the battery jumper wire through the PVC from the battery in the Second Operator to the battery in the First Operator. Use the side strain reliefs on the control boxes to run battery jumper wire into control boxes. Using spade connectors, connect positive to positive and negative to negative.

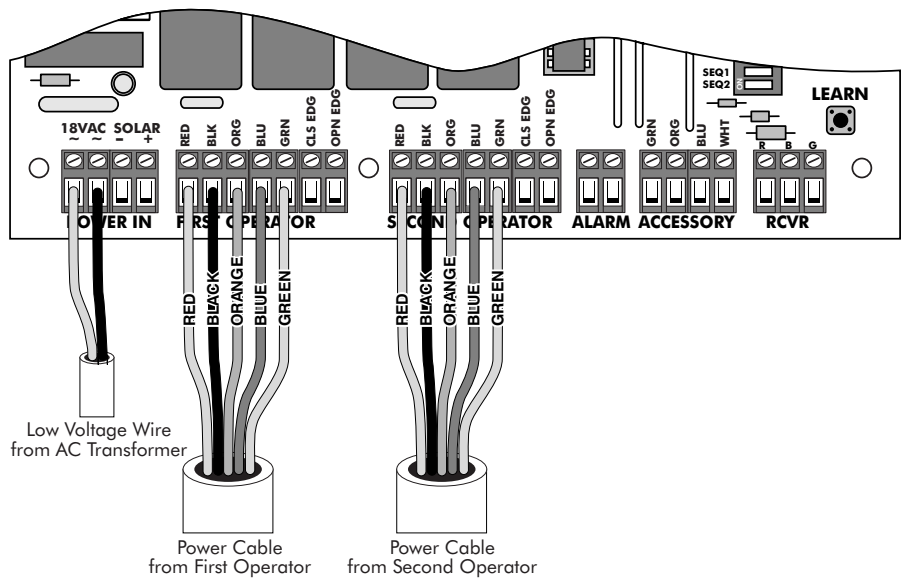

Step 2: Run the second power cable through PVC conduit to the Second Operator. Connect the wires to the motor and limit switches as shown in illustration

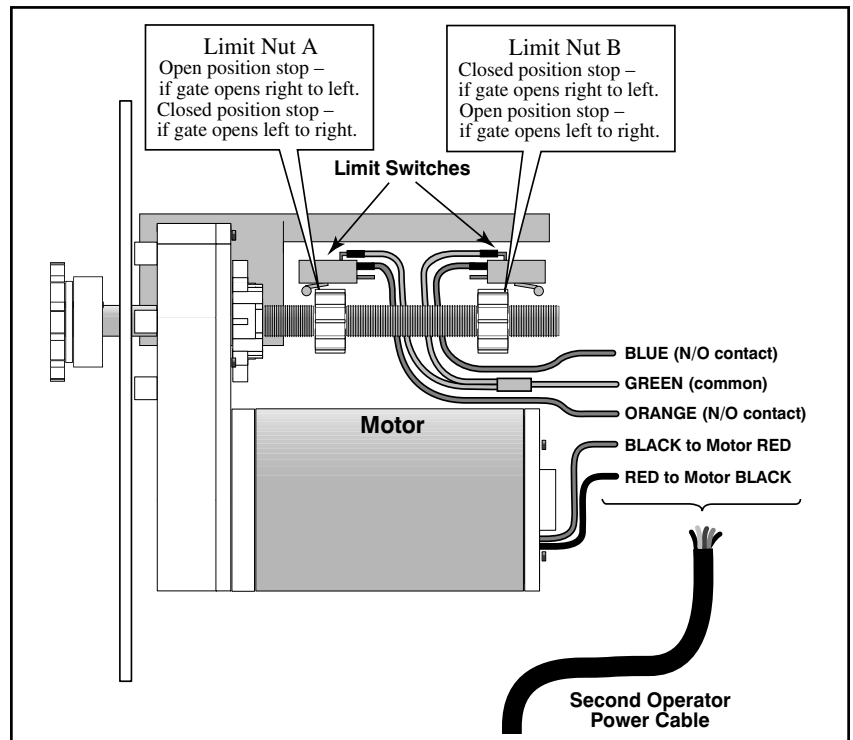

Step 3: Adjust the DIP switches on the First Operator control board for the appropriate dual gate settings, following the directions on next page.

SETTING THE CONTROL BOARD FOR DUAL GATE INSTALLATIONS

DIP SWITCHES

The Control Board DIP switches must be set to accommodate your particular type of installation. Since the **SNGL/DUAL**, **SEQ1**, and **SEQ2** DIP switches are used by dual gate operator systems, they will be discussed in the following steps.

STEP 4:

Make sure the control box power switch is **OFF**.

STEP 5:

Unscrew and remove the control box cover. Use a small screwdriver to move the **SNGL/DUAL** DIP switch to **DUAL** (see illustration).

The order of gate operation ("sequencing") must now be determined for your dual gate operators to function properly.

Refer to the illustrations on the next page.

NOTE: The terms "FIRST OPERATOR" and "SECOND OPERATOR" refer to a unit wired to the terminal block of the same name.

STEP 6:

BOTH OPERATORS OPEN SIMULTANEOUSLY
BOTH OPERATORS CLOSE SIMULTANEOUSLY

SEQ1 = ON SEQ2 = OFF

If **SEQ1** is set to **ON**, and **SEQ2** is set to **OFF**, the **FIRST OPERATOR** and **SECOND OPERATOR** **open** simultaneously, and the **FIRST OPERATOR** and **SECOND OPERATOR** **close** simultaneously (see illustration).

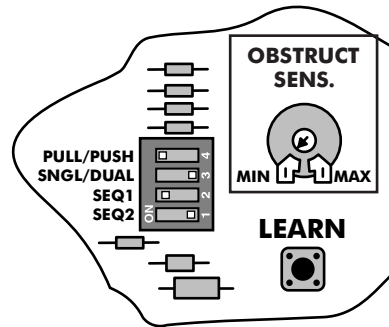
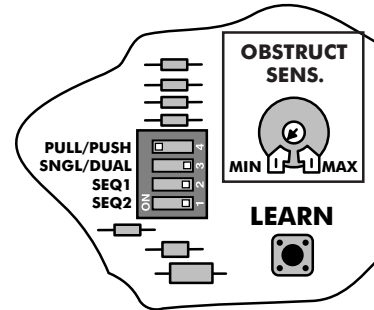

FIRST OPERATOR **OPENS** FIRST,
SECOND OPERATOR **CLOSES** FIRST

SEQ1 = OFF SEQ2 = ON

If **SEQ1** is set to **OFF**, and **SEQ2** is set to **ON**, the FIRST OPERATOR will **open** first, and the SECOND OPERATOR will **close** first (*see illustration*).

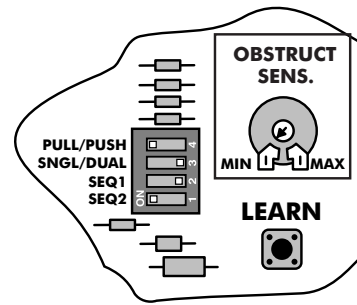

FIRST OPERATOR **OPENS** FIRST,
FIRST OPERATOR **CLOSES** FIRST

SEQ1 = ON SEQ2 = ON

If **SEQ1** is set to **ON**, and **SEQ2** is set to **ON**, The FIRST OPERATOR **opens** and **closes** first.

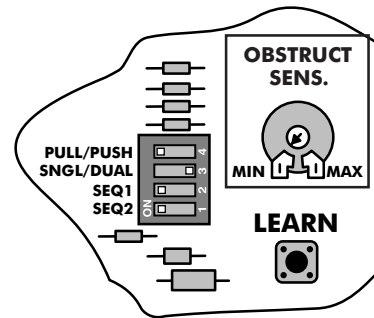

BOTH OPERATORS **OPEN** SIMULTANEOUSLY
SECOND OPERATOR **CLOSES** FIRST

SEQ1 = OFF SEQ2 = OFF

If both **SEQ1** and **SEQ2** are set to **OFF**, the FIRST OPERATOR and SECOND OPERATOR will **open** simultaneously. The SECOND OPERATOR will **close** first.

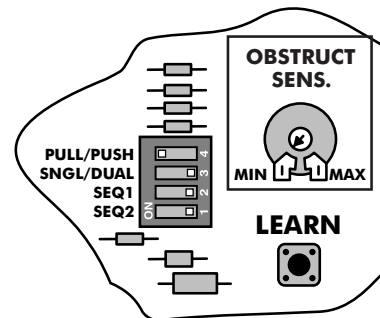

STEP 7:

Replace the control box cover. Turn the control box power switch to **ON**. Set the closed gate positions for the first and second operators by adjusting the limit switch (*review page 24*).

ACCESSORIES AVAILABLE THROUGH YOUR DEALER

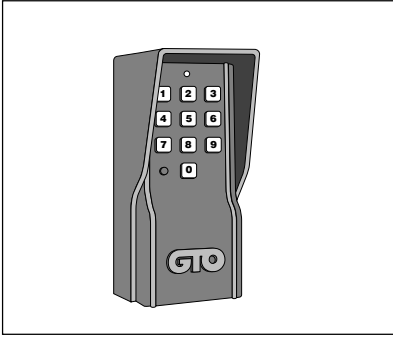

GTO Digital Keypad (F300)

The weatherproof digital keypad can be easily installed as a wired or wireless keypad for all GTO swing and slide gate operators, and as a wired keypad for the Bulldog Pedestrian Gate Lock. It can be programmed to recognize fifteen different personal identification number (PIN) codes. Each code is face programmable with additional security features built in. Requires 3 AA batteries (*not included*). Can also accommodate most garage doors and other gate openers. If used as a wired keypad, 16 gauge standard, low voltage direct burial wire will be required (*see RB509*).

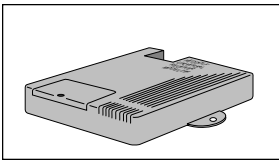

Garage Door Receiver (RB709)

Allows the use of the same GTO remote transmitter (*see Dual and Triple Transmitters*) to control the gate operator and garage door opener. Compatible with most garage door openers.

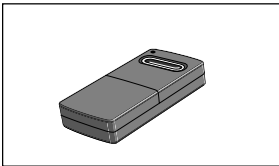

GTO Entry Transmitter (RB741)

The GTO Entry Transmitter, with adjustable code settings, is standard equipment with all GTO gate operator systems. Battery included.

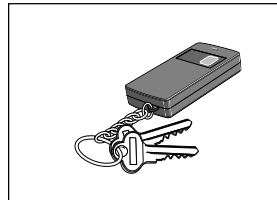

GTO Key Chain Mini Transmitter (RB744)

This miniature version of the GTO entry transmitter has the same adjustable code settings. Battery included.

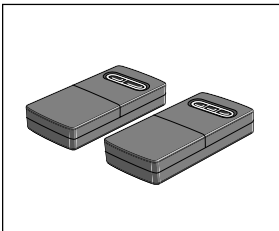

GTO Dual Transmitter (RB742)

GTO Triple Transmitter (RB743)

The two and three button transmitters are used for the remote control of two or three gate operators and garage door openers (*See Garage Door Receiver*). Battery included.

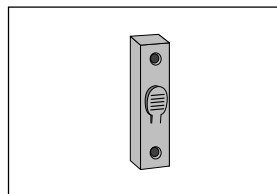

Push Button (Doorbell) Control (RB101)

Unlighted doorbell button for remote entry or exit control. Connects directly to the control board using 16 gauge stranded, low voltage, direct burial wire (*not included, see RB 509*).

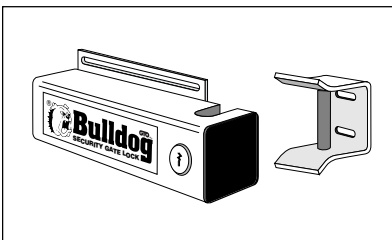

GTO Bulldog Pedestrian Gate Lock (FM500)

Similar to the Automatic Gate Lock but designed for horizontal use only on "walk-through" gates without automatic operators. The Bulldog is an affordable solution to protecting swimming pool areas, playgrounds, tennis courts, boat docks, etc., from unwanted access. Includes control box and keyed manual release. Can be used with the **GTO Digital Keypad (F300)**.

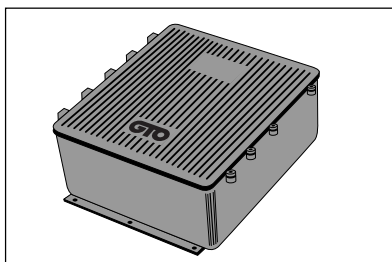

GTO NEMA Box (FM317)

GTO's NEMA 4X rated weatherproof box is large enough (14" W x 6" D x 16" H) to accommodate all add-on items necessary for custom gate operator installations. It is made of fire retardant ABS plastic and comes with a heavy duty 14 gauge steel backing plate for mounting accessories. The unique, lockable cover (use the Master[®] Pin lock RB975 for added security) can be completely removed for easier access during installation and service.

The NEMA box is standard on all **GTO/PRO AC** powered operators.

ACCESSORIES

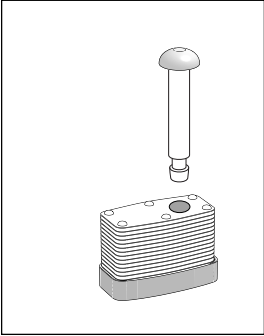

Pin Lock (RB975)

The pin lock can be inserted in the chain brackets of the GTO/PRO SL-1000/1200 and SL-2000/2200 to prevent unauthorized removal of the quick release pins.

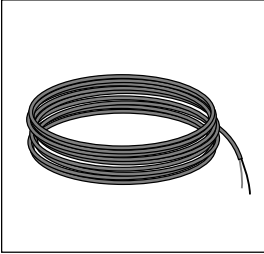

GTO Low Voltage Wire (RB509)

The 16 gauge dual conductor, multi-stranded, direct burial low voltage wire is required to connect the control board to the solar panel or the AC transformer. This wire is also required for installation of some accessories such as keypads, locks, or push buttons (*available in 1000' rolls and specially cut lengths*).

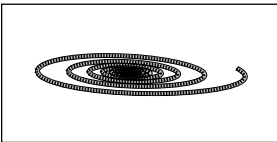

#41 Slide Gate Chain (RB207)

The #41 chain (*32' only*) is used with the **GTO/PRO SL-1000/1200** and **SL-2000/22000** DC Slide Gate Operators.

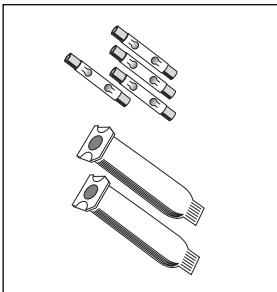

Splice Kit - Above Ground (RB707)

For providing secure and moisture resistant above ground splices for solar panels, key pads, push buttons and other accessories using GTO low voltage wire.

Splice Kit - Direct Burial (RB708)

When direct burial wire running below ground needs to be spliced the **RB708** splice kit **must** be used.

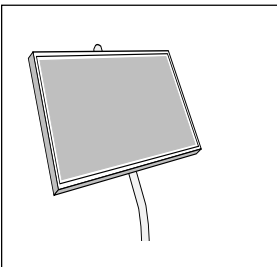

Operator Solar Panel (FM123) - Improved, Amorphous Silicon (Two Year Warranty*)

This 10 watt solar panel is a battery charger for use with **GTO/PRO Low Voltage Automatic Gate Operator** systems. Particularly suited for remote installations, the solar panel comes with tubular steel support, mounting clips, wire connectors, and 8 ft. of low voltage wire (*for longer lengths, see RB509*). All GTO low voltage operators are pre-wired for solar panels. Installation in some regions of the world will require multiple panels for adequate charging power. Recommended for **GTO/PRO SL-2000/2200**, **GTO/PRO SL-1000/1200**.

NOTE: GTO/PRO SL-2000 requires the 24 Amp Hour Battery Kit for solar applications.

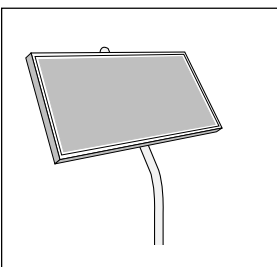

Operator Solar Panel (FM122) - Improved Amorphous Silicon (Two Year Warranty*)

The 5 watt solar panel is a battery charger for use with **GTO/PRO Low Voltage Automatic Gate Operator** systems. Particularly suited for remote installations, the solar panel comes with tubular steel support, mounting clips, wire connectors, and 8 ft. of low voltage wire (*see Low Voltage Wire for longer wire*). All GTO low voltage operators are pre-wired for solar panels. Installation in some regions of the world will require multiple panels for adequate charging power. Recommended for **GTO/PRO SL-1000**, **GTO/PRO SL-2000** and the **GTO Bulldog Gate Lock**. Dual gate installations require minimum of two (2) 5 watt solar panels for adequate charging power.

NOTE: GTO/PRO SL-2000 requires the 24 Amp Hour Battery Kit for solar applications.

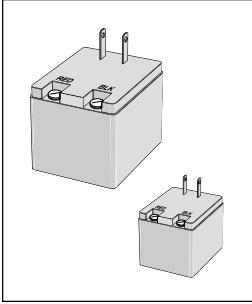

Standard Replacement Transformer (RB570) –Standard 18 volt AC transformer for **GTO/PRO SL-1000 and SL-2000** series gate operators

Bulldog Replacement Charger (RB422) – Standard 12 volt DC charger for maintaining battery included with the Bulldog Pedestrian Gate Lock.

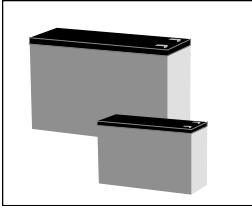

Replacement Batteries

RB500 – The standard 12 volt, 7.0 ampere-hour, maintenance-free battery for all **GTO/PRO** gate operators. This is the only battery approved for use with **GTO** gate operators. Battery life 3 to 5 years.

RB422 –The 12 volt, 1.2 ampere-hour version for use with the Bulldog Pedestrian Gate Lock.

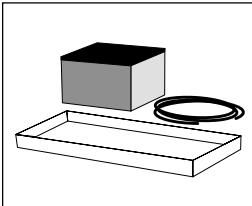

GTO/PRO 24 Amp Hour Battery Kit

FB295 – This large 12 volt, 24 ampere-hour, maintenance-free battery is for the **GTO/PRO SL-2000&2200** gate operators. It will supply additional power for increasing the number of open and close cycles of the **GTO/PRO SL-2000&2200** operators. The kit comes with the battery, battery pan and wiring harness for easy installation inside the existing operator housing. This is the only battery approved for use with **GTO** gate operators. Battery life 3 to 5 years.

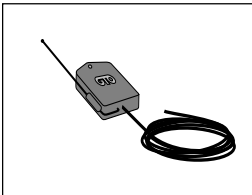

Replacement Receivers

The **AQ202**: Receiver with a 20 ft. cable (included).

The **AWQ325**: Receiver with a 25 ft. cable.

The **AWQ350**: Receiver with a 50 ft. cable.

The **AWQ400**: Receiver with a 100 ft. cable.

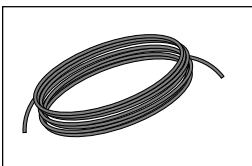

Standard Replacement Power Cables for Gate Operators

The **PRO 60C (AC202)**: 60 ft. power cable included with **GTO SL-1200 and SL-2200** dual (second) slide gate operator.

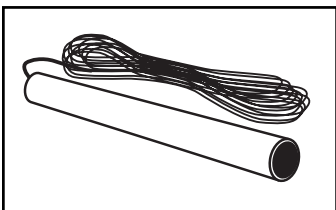

GTO EXIT WAND (FM138)

The GTO Exit Wand is designed for residential and agricultural applications and is compatible with all the GTO/PRO automatic gate opener models. The Exit Wand is an electromagnetic sensor, which offers 'hands free' operation of automatic gate openers with a 12 ft. radius of detection of vehicles in motion.

** GTO, Inc. gate operator accessories are warranted by the manufacturer against defects in materials and workmanship for a period of one year, unless otherwise stated, from the date of purchase provided recommended installation procedures have been followed. Warranty is considered void if damage was due to improper installation or use, connection to an improper power source, or was caused by lightning, wind, fire, flood, insects, or other natural agent.*

INSTALLATION CHECK LIST

The installation of this operator conforms to CLASS _____.

The installer verifies that (each item must be checked):

- ___ Required safety edges were installed.
- ___ Roller guards were installed over gate rollers.
- ___ Fence was screened so that no one can reach through the gate to operate controls.
- ___ Customer was informed that this gate is for vehicular use **ONLY**. Pedestrians **MAY NOT** use this gate.
- ___ A separate gate or entrance was installed for pedestrian use.
- ___ All warning signs and labels were installed as specified in the **IMPORTANT SAFETY INSTRUCTIONS**.

- ___ Safety instructions were reviewed with the customer.
- ___ The **IMPORTANT SAFETY INSTRUCTIONS** manual was given to the customer.
- ___ Customer was instructed about proper use of the foot pedal release.
- ___ Customer was instructed about proper use of transmitter and (or) other entry controls.
- ___ Customer was asked to fill out customer support card and mail it to GTO, Inc.
- ___ Customer was asked to retain **all receipts** (receipts provide proof of warranty).
- ___ Customer was asked to retain **IMPORTANT SAFETY INSTRUCTIONS**, etc. for future reference.
- ___ The completed installation was photographed from both the front and back of the gate. Photo was dated.

Customer's Signature

Date

Installer's Signature

Date