

# *Grizzly* *Industrial, Inc.*®

## MODEL G0459 12" DRUM SANDER OWNER'S MANUAL



COPYRIGHT © OCTOBER, 2005 BY GRIZZLY INDUSTRIAL, INC., REVISED MAY, 2007 (BL)  
**WARNING: NO PORTION OF THIS MANUAL MAY BE REPRODUCED IN ANY SHAPE  
OR FORM WITHOUT THE WRITTEN APPROVAL OF GRIZZLY INDUSTRIAL, INC.**  
#BL7307 PRINTED IN TAIWAN



# WARNING!

Some dust created by power sanding, sawing, grinding, drilling, and other construction activities contains chemicals known to the State of California to cause cancer, birth defects or other reproductive harm. Some examples of these chemical are:

- Lead from lead-based paints.
- Crystalline silica from bricks, cement and other masonry products.
- Arsenic and chromium from chemically-treated lumber.

Your risk from these exposures varies, depending on how often you do this type of work. To reduce your exposure to these chemicals: Work in a well ventilated area, and work with approved safety equipment, such as those dust masks that are specially designed to filter out microscopic particles.

## WARNING

The safety labels on this machine warn and indicate how to protect the operator or bystander from machine hazards. The machine owner **MUST** maintain the original label location and readability. If a label is removed or becomes unreadable, **REPLACE** the label before using the machine. For new labels, contact Grizzly Industrial Inc. at (570) 546-9663 or [techsupport@grizzly.com](mailto:techsupport@grizzly.com).

# Table of Contents

- INTRODUCTION..... 3**
  - Foreword ..... 3
  - Contact Info ..... 3
  - Machine Data Sheet..... 4
  - Identification ..... 5
- SECTION 1: SAFETY ..... 6**
  - Safety Instructions for Machinery..... 6
  - Additional Safety for Drum Sanders..... 8
- SECTION 2: CIRCUIT REQUIREMENTS ..... 9**
  - 110V Operation ..... 9
- SECTION 3: SET UP ..... 10**
  - Set Up Safety ..... 10
  - Items Needed for Set Up ..... 10
  - Unpacking ..... 10
  - Inventory..... 11
  - Site Considerations ..... 11
  - Placing Sander..... 12
  - Mounting..... 12
  - Installing Crank Handle ..... 13
  - Dust Collection ..... 13
  - Test Run..... 14
  - Recommended Adjustments ..... 14
- SECTION 4: OPERATIONS ..... 15**
  - Operation Safety ..... 15
  - Switch/Lockout ..... 15
  - Depth of Cut..... 16
  - Variable Speed..... 16
  - Sanding ..... 17
  - Sanding Tips ..... 17
  - Choosing Sandpaper ..... 18
  - Paper Replacement ..... 18
- SECTION 5: ACCESSORIES ..... 19**
- SECTION 6: MAINTENANCE ..... 21**
  - Schedule ..... 21
  - Cleaning ..... 21
  - Lubrication..... 21

<b>SECTION 7: SERVICE .....</b>	<b>23</b>
Troubleshooting.....	23
Gauge Blocks.....	26
V-Belt Service .....	26
Conveyor Tensioning & Tracking.....	28
Drum Adjustments.....	29
Pressure Roller Height .....	31
Scale Pointer Calibration.....	32
Table Lift Screws.....	33
Conveyor Belt Replacement .....	34
Electrical Components .....	39
Wiring Diagram .....	40
Frame Parts Breakdown .....	41
Drum and Conveyor Parts Breakdown .....	42
Parts List .....	43
Parts List .....	44
Safety Label Placement and Parts List.....	45
<b>WARRANTY AND RETURNS .....</b>	<b>46</b>

# INTRODUCTION

---

---

## Foreword

---

---

We are proud to offer the Model G0459 12" Drum Sander. This machine is part of a growing Grizzly family of fine woodworking machinery. When used according to the guidelines set forth in this manual, you can expect years of trouble-free, enjoyable operation and proof of Grizzly's commitment to customer satisfaction.

We are pleased to provide this manual with the Model G0459. It was written to guide you through assembly, review safety considerations, and cover general operating procedures. It represents our effort to produce the best documentation possible.

The specifications, drawings, and photographs illustrated in this manual represent the Model G0459 as supplied when the manual was prepared. However, owing to Grizzly's policy of continuous improvement, changes may be made at any time with no obligation on the part of Grizzly. For your convenience, we always keep current Grizzly manuals available on our website at **www.grizzly.com**. Any updates to your machine will be reflected in these manuals as soon as they are complete. Visit our site often to check for the latest updates to this manual!

## Contact Info

---

---

If you have any comments regarding this manual, please write to us at the address below:

Grizzly Industrial, Inc.  
c/o Technical Documentation Manager  
P.O. Box 2069  
Bellingham, WA 98227-2069

We stand behind our machines. If you have any service questions or parts requests, please call or write us at the location listed below.

Grizzly Industrial, Inc.  
1203 Lycoming Mall Circle  
Muncy, PA 17756  
Phone: (570) 546-9663  
Fax: (800) 438-5901  
E-Mail: [techsupport@grizzly.com](mailto:techsupport@grizzly.com)  
Web Site: <http://www.grizzly.com>





# MACHINE DATA SHEET

Customer Service #: (570) 546-9663 • To Order Call: (800) 523-4777 • Fax #: (800) 438-5901

## MODEL G0459 12" DRUM SANDER

Design Type ..... Bench Model

### Overall Dimensions:

Height ..... 23"  
 Width ..... 26½"  
 Depth ..... 24"  
 Table Height ..... 17"  
 Carton Size ..... 26.77" L x 25.2" W x 26.4" H  
 Base Footprint ..... 12" x 22¼"  
 Shipping Weight ..... 146 lbs.  
 Net Weight ..... 139 lbs.

### Capacities:

Maximum Board Width ..... 12"  
 Maximum Board Thickness ..... 3½"  
 Minimum Board Length ..... 8"  
 Minimum Board Thickness ..... ⅛"  
 Surface Speed of Drum ..... 2300 FPM  
 Conveyor Feed Rate ..... Variable, 0-15 FPM

### Sanding Drum Motor:

Type ..... TEFC Capacitor Start Induction  
 Horsepower ..... 1½ HP  
 Voltage ..... 110V Only  
 Amps ..... 18A  
 Motor Speed ..... 3450 RPM  
 Phase / Cycle ..... Single / 60 HZ  
 Power Transfer ..... V-Belt Drive

### Conveyor Motor:

Type ..... DC, Variable Speed Gear Motor  
 Horsepower ..... 0.1 HP  
 Voltage ..... 110V Only  
 Amps ..... 0.7  
 Power Transfer ..... Chain Drive  
 Switch ..... Toggle Safety ON/OFF

### General Construction:

Frame ..... Steel  
 Sanding Drum (1) ..... 4" Diameter Aluminum  
 Pressure Rollers (2) ..... 1½" Diameter Rubber  
 Conveyor Belt ..... 12¾" x 49¾" Continuous Industrial Quality Belt  
 ..... 2½" Dust Port Included  
 ..... Uses 3" Wide Hook and Loop Sandpaper  
 ..... Variable Speed Conveyor

*Specifications, while deemed accurate, are not guaranteed.*



# Identification

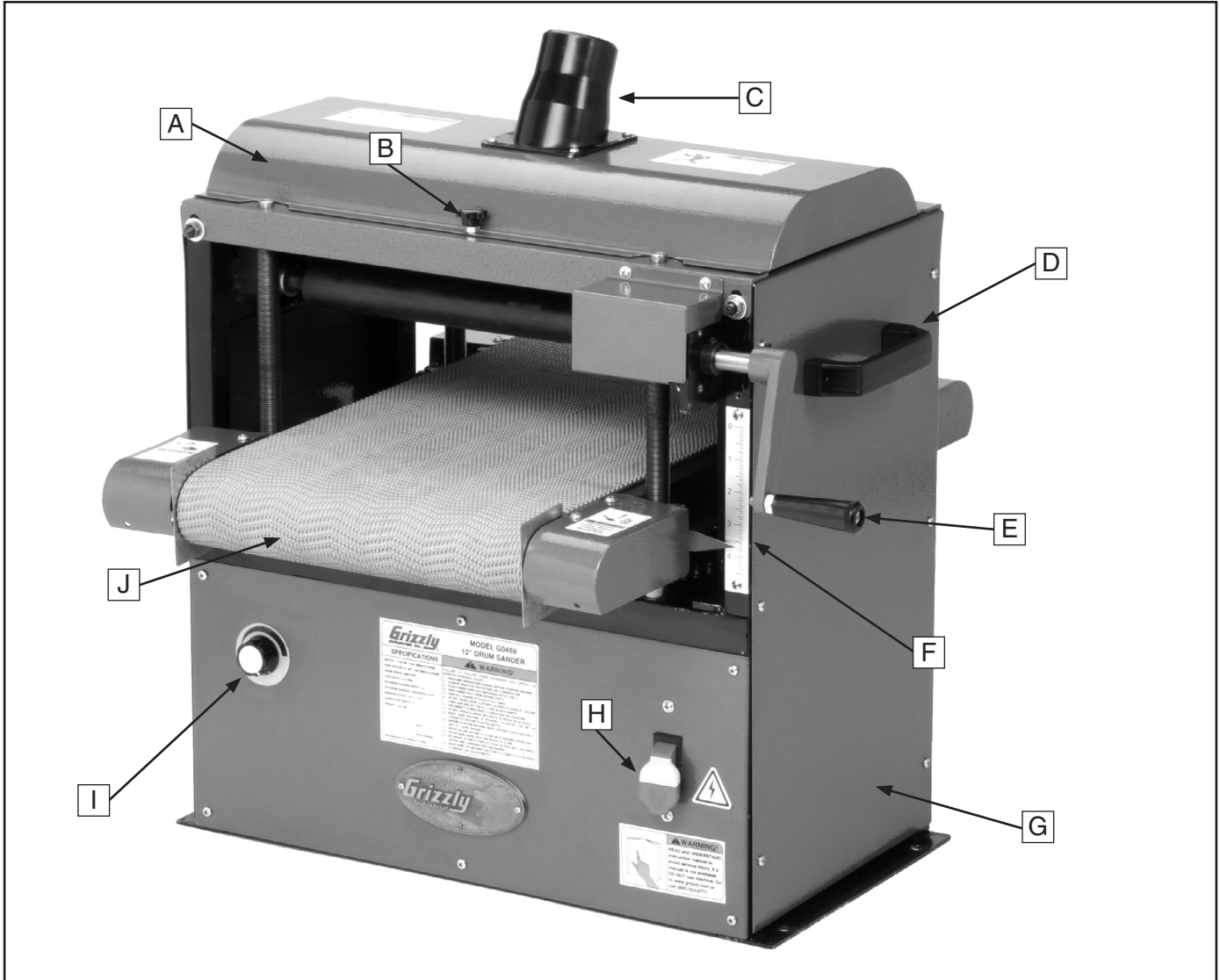

**Figure 1.** Front view, Model G0459.

- A. Top Cover
- B. Cover Lock Knob
- C. Dust Port
- D. Handle
- E. Crank Handle
- F. Depth Scale
- G. Drum Sander Frame
- H. ON/OFF Switch
- I. Variable Speed Control
- J. Conveyor Belt



# SECTION 1: SAFETY

## **WARNING**

### **For Your Own Safety, Read Instruction Manual Before Operating this Machine**

The purpose of safety symbols is to attract your attention to possible hazardous conditions. This manual uses a series of symbols and signal words which are intended to convey the level of importance of the safety messages. The progression of symbols is described below. Remember that safety messages by themselves do not eliminate danger and are not a substitute for proper accident prevention measures.

 **DANGER** Indicates an imminently hazardous situation which, if not avoided, **WILL** result in death or serious injury.

 **WARNING** Indicates a potentially hazardous situation which, if not avoided, **COULD** result in death or serious injury.

 **CAUTION** Indicates a potentially hazardous situation which, if not avoided, **MAY** result in minor or moderate injury. It may also be used to alert against unsafe practices.

**NOTICE** This symbol is used to alert the user to useful information about proper operation of the machine.

## **WARNING**

### **Safety Instructions for Machinery**

- 1. READ THROUGH THE ENTIRE MANUAL BEFORE STARTING MACHINERY.** Machinery presents serious injury hazards to untrained users.
- 2. ALWAYS USE ANSI APPROVED SAFETY GLASSES WHEN OPERATING MACHINERY.** Everyday eyeglasses only have impact resistant lenses, they are NOT safety glasses.
- 3. ALWAYS WEAR AN ANSI APPROVED RESPIRATOR WHEN OPERATING MACHINERY THAT PRODUCES DUST.** Wood dust is a carcinogen and can cause cancer and severe respiratory illnesses.
- 4. ALWAYS USE HEARING PROTECTION WHEN OPERATING MACHINERY.** Machinery noise can cause permanent hearing damage.
- 5. WEAR PROPER APPAREL. DO NOT** wear loose clothing, gloves, neckties, rings, or jewelry which may get caught in moving parts. Wear protective hair covering to contain long hair and wear non-slip footwear.
- 6. NEVER OPERATE MACHINERY WHEN TIRED, OR UNDER THE INFLUENCE OF DRUGS OR ALCOHOL.** Be mentally alert at all times when running machinery.





# WARNING

## Safety Instructions for Machinery

7. **ONLY ALLOW TRAINED AND PROPERLY SUPERVISED PERSONNEL TO OPERATE MACHINERY.** Make sure operation instructions are safe and clearly understood.
8. **KEEP CHILDREN AND VISITORS AWAY.** Keep all children and visitors a safe distance from the work area.
9. **MAKE WORKSHOP CHILD PROOF.** Use padlocks, master switches, and remove start switch keys.
10. **NEVER LEAVE WHEN MACHINE IS RUNNING.** Turn power **OFF** and allow all moving parts to come to a complete stop before leaving machine unattended.
11. **DO NOT USE IN DANGEROUS ENVIRONMENTS.** DO NOT use machinery in damp, wet locations, or where any flammable or noxious fumes may exist.
12. **KEEP WORK AREA CLEAN AND WELL LIT.** Clutter and dark shadows may cause accidents.
13. **USE A GROUNDED EXTENSION CORD RATED FOR THE MACHINE AMPERAGE.** Undersized cords overheat and lose power. Replace extension cords if they become damaged. DO NOT use extension cords for 220V machinery.
14. **ALWAYS DISCONNECT FROM POWER SOURCE BEFORE SERVICING MACHINERY.** Make sure switch is in OFF position before reconnecting.
15. **MAINTAIN MACHINERY WITH CARE.** Keep blades sharp and clean for best and safest performance. Follow instructions for lubricating and changing accessories.
16. **MAKE SURE GUARDS ARE IN PLACE AND WORK CORRECTLY BEFORE USING MACHINERY.**
17. **REMOVE ADJUSTING KEYS AND WRENCHES.** Make a habit of checking for keys and adjusting wrenches before turning machinery **ON**.
18. **CHECK FOR DAMAGED PARTS BEFORE USING MACHINERY.** Check for binding and alignment of parts, broken parts, part mounting, loose bolts, and any other conditions that may affect machine operation. Repair or replace damaged parts.
19. **USE RECOMMENDED ACCESSORIES.** Refer to the instruction manual for recommended accessories. The use of improper accessories may cause risk of injury.
20. **DO NOT FORCE MACHINERY.** Work at the speed for which the machine or accessory was designed.
21. **SECURE WORKPIECE.** Use clamps or a vise to hold the workpiece when practical. A secured workpiece protects your hands and frees both hands to operate the machine.
22. **DO NOT OVERREACH.** Keep proper footing and balance at all times.
23. **MANY MACHINES WILL EJECT THE WORKPIECE TOWARD THE OPERATOR.** Know and avoid conditions that cause the workpiece to "kickback."
24. **ALWAYS LOCK MOBILE BASES (IF USED) BEFORE OPERATING MACHINERY.**
25. **BE AWARE THAT CERTAIN WOODS MAY CAUSE AN ALLERGIC REACTION** in people and animals, especially when exposed to fine dust. Make sure you know what type of wood dust you will be exposed to and always wear an approved respirator.



# WARNING

## Additional Safety for Drum Sanders

- 1. FEEDING STOCK.** DO NOT allow anyone to stand directly in front of this sander when feeding your stock. Never sand more than one piece of stock at a time.  
  
DO NOT jam the workpiece into the machine during operation. Firmly grasp the workpiece in both hands and ease it into the machine using light pressure.
- 2. MINIMUM STOCK DIMENSIONS.** DO NOT sand any stock thinner than  $\frac{1}{8}$ ", narrower than  $\frac{1}{8}$ ", or shorter than 8". DO NOT sand thin stock by using a "dummy" board under your workpiece.
- 3. CLOTHING.** DO NOT wear loose clothing while operating this machine. Roll up or button sleeves at the cuff.
- 4. HAND PROTECTION.** DO NOT place hands near, or in contact with, sanding drums during operation. DO NOT allow fingers to get pinched between board and conveyor belt during operation. This may pull the operator's hand into the machine and cause serious injury or death!
- 5. INSPECTING WORKPIECES.** Always inspect one workpiece at a time for nails, staples, knots, and other imperfections that could be dislodged and thrown from the machine during sanding operations.
- 6. DUST COLLECTION SYSTEM.** Never operate the sander without an adequate dust collection system in place and running.
- 7. BE ATTENTIVE.** Never leave the machine running unattended.
- 8. REPLACING SANDING PAPER.** Replace sanding paper when it becomes worn or damaged.
- 9. EXPERIENCING DIFFICULTIES.** Any problem, with the exception of conveyor or belt tracking that is concerned with any moving parts or accessories, must be investigated and corrected with the power disconnected, and after all moving parts have come to a complete stop.
- 10. MAINTENANCE AND ADJUSTMENTS.** Never attempt to adjust conveyor belt tracking when the sanding drums are running. Perform machine inspections and maintenance service promptly when called for. Disconnect power before performing maintenance or adjustments on the sander.
- 11. RESPIRATOR AND SAFETY GLASSES.** Always wear a respirator and safety glasses while operating the machine. Dust and chips are created when sanding. Some debris will be ejected, becoming hazards to the eyes and lungs.

### WARNING

Like all machines there is danger associated with the Model G0459. Accidents are frequently caused by lack of familiarity or failure to pay attention. Use this machine with respect and caution to lessen the possibility of operator injury. If normal safety precautions are overlooked or ignored, serious personal injury may occur.

### CAUTION

No list of safety guidelines can be complete. Every shop environment is different. Always consider safety first, as it applies to your individual working conditions. Use this and other machinery with caution and respect. Failure to do so could result in serious personal injury, damage to equipment, or poor work results.



# SECTION 2: CIRCUIT REQUIREMENTS

## 110V Operation

### **!WARNING**

Serious personal injury could occur if you connect the machine to the power source before you have completed the set up process. **DO NOT** connect the machine to the power source until instructed to do so.

### Amperage Draw

The a 1½ HP motor on the Model G0459 will draw the following amps:

Motor Draw ..... 18 Amps

### Circuit Requirements

Only connect your machine to a circuit that meets the requirements below. Always check to see if the wires and circuit breaker in your circuit are capable of handling the amperage draw from your machine, as well as any other machines that could be operating on the same circuit. If you are unsure, consult a qualified electrician.

Minimum Circuit Requirement .....25 Amp

### Plug/Receptacle Type

Included Plug Type ..... NEMA 5-15

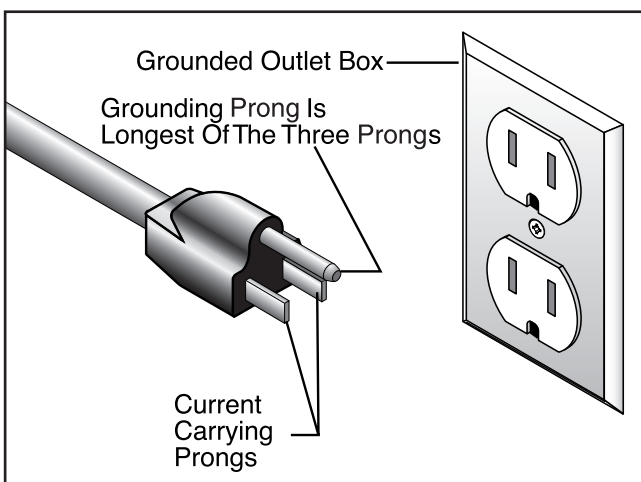

**Figure 2.** Typical type 5-15 plug and receptacle.

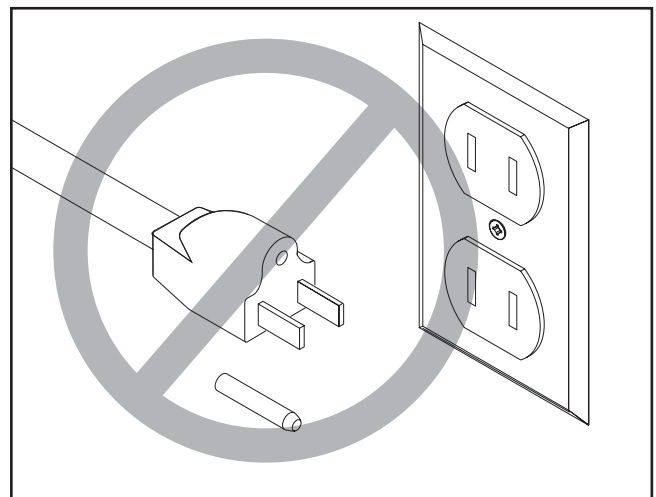
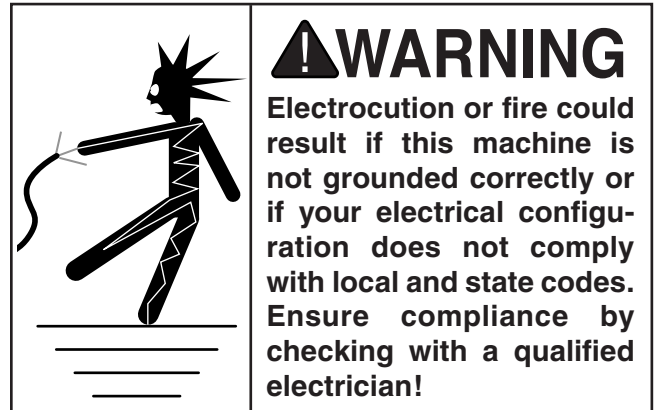

### **!CAUTION**

This machine must have a ground prong in the plug to help ensure that it is grounded. **DO NOT** remove ground prong from plug to fit into a two-pronged outlet! If the plug will not fit the outlet, have the proper outlet installed by a qualified electrician.

### Extension Cords

We do not recommend the use of extension cords. If you find it absolutely necessary to use an extension cord with your machine:

- Use at least a 10 gauge cord that does not exceed 50 feet in length!
- The extension cord must also contain a ground wire and plug pin.
- A qualified electrician **MUST** size cords over 50 feet long to prevent motor damage.



# SECTION 3: SET UP

## Set Up Safety

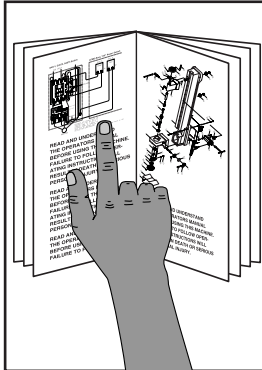

**!WARNING**  
This machine presents serious injury hazards to untrained users. Read through this entire manual to become familiar with the controls and operations before starting the machine!



**!WARNING**  
Wear safety glasses during the entire set up process!

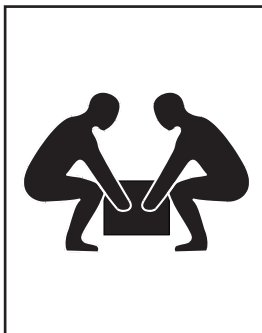

**!WARNING**  
The Model G0459 is a heavy machine (146 lbs. shipping weight). DO NOT over-exert yourself while unpacking or moving your machine—get assistance.

## Items Needed for Set Up

The following items are needed to complete the set up process, but are not included with your machine:

Description	Qty
• Safety Glasses (for each person) .....	1
• An Assistant .....	1
• Dust Collection System .....	1
• Dust Hoses 2½" .....	(Length Varies)
• Hose Clamp 2½" .....	(Varies)
• Lag Bolts 5/16-18 x 40 (Not Included) .....	4
• Open End Wrench or Socket ½" .....	1
• Phillips Head Screwdriver #2 .....	1
• Drill .....	1
• Drill Bit ¼" .....	1

## Unpacking

The Model G0459 was carefully packed when it left our warehouse. If you discover the machine is damaged after you have signed for delivery, please immediately call Customer Service at (570) 546-9663 for advice.

Save the containers and all packing materials for possible inspection by the carrier or its agent. Otherwise, filing a freight claim can be difficult.

When you are completely satisfied with the condition of your shipment, you should inventory the contents.



# Inventory

After all the parts have been removed from the two boxes, you should have the following items:

Box 1: (Figure 3)	Qty
A. Drum Sander .....	1
B. Crank Handle .....	1
C. 2½" Dust Port .....	1
D. 3mm Hex Wrench .....	1

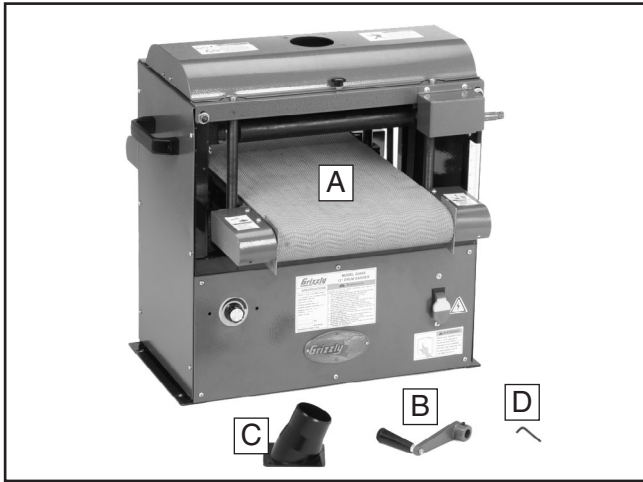

Figure 3. G0459 Inventory.

In the event that any nonproprietary parts are missing (e.g. a nut or a washer), we would be glad to replace them, or for the sake of expediency, replacements can be obtained at your local hardware store.

# Site Considerations

## Floor Load

Refer to the **Machine Data Sheet** for the weight and footprint specifications of your machine. Some workbenches may require additional reinforcement to support both the machine and the workpiece.

## Working Clearances

Consider existing and anticipated needs, size of material to be processed through each machine, and space for auxiliary stands, work tables or other machinery when establishing a location for your new machine. See **Figure 4** for the minimum working clearances.

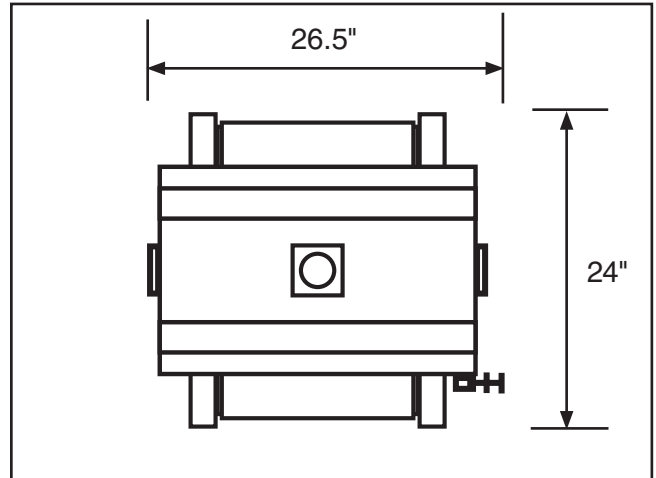
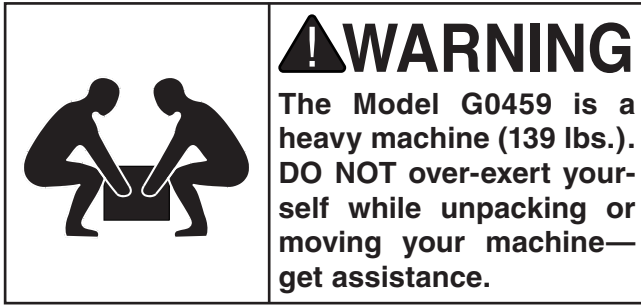

Figure 4. Minimum working clearances.

	<p><b>⚠ CAUTION</b></p> <p>Unsupervised children and visitors inside your shop could cause serious personal injury to themselves. Lock all entrances to the shop when you are away and <b>DO NOT</b> allow unsupervised children or visitors in your shop at any time!</p>
--	----------------------------------------------------------------------------------------------------------------------------------------------------------------------------------------------------------------------------------------------------------------------------



# Placing Sander



## To place the sander in a permanent location:

1. With an assistant's help, lift the sander out of the box and move it to your predetermined location.

# Mounting

Components and Hardware Needed:	Qty
Lag Bolts $\frac{5}{16}$ -18 x 40 (Not Included)	4
Flat Washers $\frac{5}{16}$ (Not Included)	4

## To mount the drum sander to a bench top:

1. Place the sander on a bench top capable of holding approximately 140 lbs. plus the weight of the workpiece. Make sure the surface is flat and stable.
2. Drill four  $\frac{1}{4}$ " holes on the bench, using the holes in the base as a guide.
3. Using a  $\frac{1}{2}$ " wrench, bolt the base to the bench top with  $\frac{5}{16}$ " lag bolts and flat washers as shown in **Figure 5**.



**Figure 5.** Installing sander onto bench top.



# Installing Crank Handle

Components and Hardware Needed:	Qty
Crank Handle .....	1

The crank handle is installed on the front right lift screw shaft, and is held in place with two set screws already threaded into the handle.

### To mount the handwheel:

1. Place the crank handle over the shaft shown in **Figure 6** and, using a 3mm hex wrench, secure the handle with the two set screws.

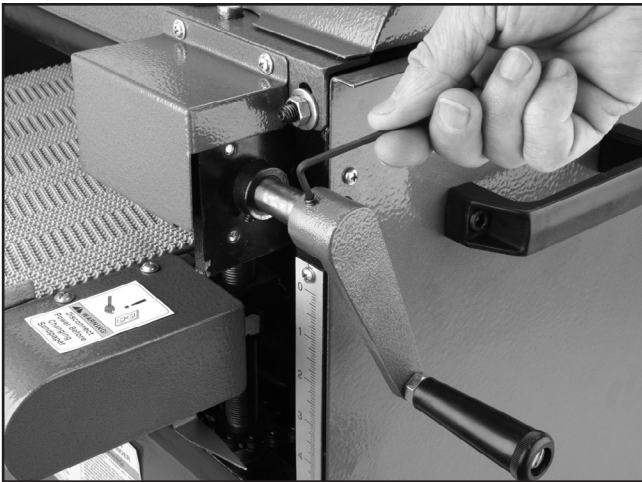

**Figure 6.** Crank handle installation.

# Dust Collection

Components and Hardware Needed:	Qty
Dust Hoses 2½" (not included).....	Length Varies
Hose Clamps (not included).....	Varies
Dust Collection System (not included) .....	1

This drum sander requires a minimum of 400 CFM **AT THE DUST PORT**.

**Note:** Do not confuse this CFM recommendation with the rating of the dust collector. To determine the CFM at the dust port, you must take into account many variables, including the rating of the dust collector, the length of hose between the dust collector and the machine, the amount of branches or wyes, and the amount of other open lines throughout the system.

A fine layer of dust will be present on your stock as it comes out of the sander. This is normal.

### To connect the dust port to a dust collector:

1. Remove the four Phillips head screws at the dust port hole.
2. Place the 2½" dust port over the top cover mounting holes and secure with the Phillips head screws removed in **Step 1** as shown in **Figure 7**.
3. Attach a 2½" dust collection hose to the dust port and secure it with a hose clamp.

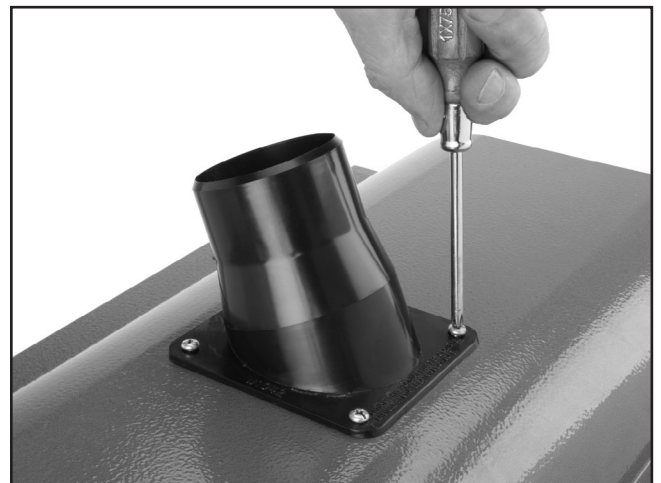

**Figure 7.** Dust port installation.

4. Connect the sander to the power source.



# Test Run

---

---

Now that the machine is connected to the power source, it is important to perform a test run to make sure all the controls are working properly.

## **WARNING**

**Before starting the sander, make sure you have performed the preceding assembly and adjustment instructions, and you have read through the rest of the manual and are familiar with the various functions and safety issues associated with this machine. Failure to follow this warning could result in serious personal injury or even death!**

### To test run the sander:

1. Put on safety glasses and make sure any bystanders are out of the way and also wearing safety glasses.
2. Flip the ON/OFF switch **ON**. Make sure that your finger is poised over the ON/OFF switch, just in case there is a problem.

The drum sander should run smoothly, with little or no vibration or rubbing noises. Strange or unnatural noises should be investigated and corrected before operating the machine further. To avoid injury or damage to the machine, **DO NOT** attempt to make adjustments to the machine without turning it **OFF** and unplugging it from its power source.

Investigate and correct any problems before operating the machine further. If you need help, refer to the **Troubleshooting** section in the back of this manual or contact Tech Support at (570) 546-9663.

# Recommended Adjustments

---

---

For your convenience, the adjustments listed below have been performed at the factory and no further setup is required to operate your machine.

However, because of the many variables involved with shipping, some of these adjustments may need to be repeated to ensure optimum results. Keep this in mind as you start to use your new drum sander.

**Step-by-step instructions for these adjustments can be found in SECTION 7: SERVICE ADJUSTMENTS.**

1. V-Belt Service (**Page 26**). Perform after the first 16 hours.
2. Conveyor Tensioning & Tracking (**Page 28**).
3. Drum Adjustments (**Page 29**).
4. Pressure Roller Height (**Page 31**).





# SECTION 4: OPERATIONS

## Operation Safety

### **!WARNING**

Damage to your eyes, lungs, and ears could result from using this machine without proper protective gear. Always wear safety glasses, a respirator, and hearing protection when operating this machine.

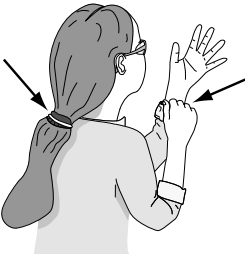
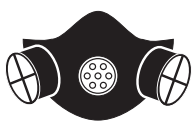

### **!WARNING**

Loose hair and clothing could get caught in machinery and cause serious personal injury. Keep loose clothing and long hair away from moving machinery.

### **NOTICE**

If you have never used this type of machine or equipment before, WE STRONGLY RECOMMEND that you read books, trade magazines, or get formal training before beginning any projects. Regardless of the content in this section, Grizzly Industrial will not be held liable for accidents caused by lack of training.

## Switch/Lockout

The ON/OFF switch can be locked-out to prevent unauthorized use.

To turn the switch **ON** and **OFF**:

1. To turn the sander **ON**, flip the switch up.
2. To turn the sander **OFF**, press the switch down.
3. To lock-out the switch, remove the yellow key from the switch housing, as shown in **Figure 8**. Place the key in a safe place.

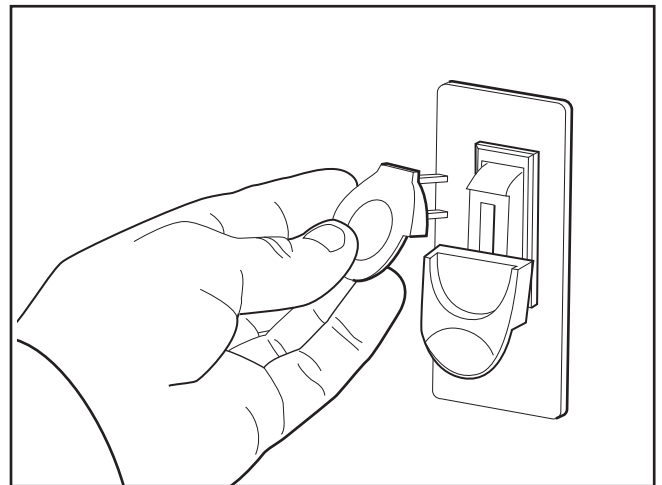

Figure 8. Locking-out.



# Depth of Cut

The optimum depth of cut will vary based on the type of wood, feed rate, and sandpaper grit. Under most sanding conditions, the depth should not exceed 0.006" (0.15 mm) (approx. ¼ turn of the handwheel). Each full turn of the crank handle raises the conveyor table approximately 0.027" (0.69 mm). Attempts to remove too much material can cause jamming, wood burning, rapid paper wear or tearing, poor finish, belt slippage, and motor damage.

## To set the depth of cut:

1. Rotate the crank handle (**Figure 9**) until the table is well below the sanding drum, then raise the table, allowing a gap between the workpiece and the drum.

**Note:** When adjusting the table to sand a thicker workpiece, lower and then raise the table to remove backlash from the adjustment mechanism. If the table is lowered too far, the conveyor belt may rub against the chain, leaving grease on the belt.

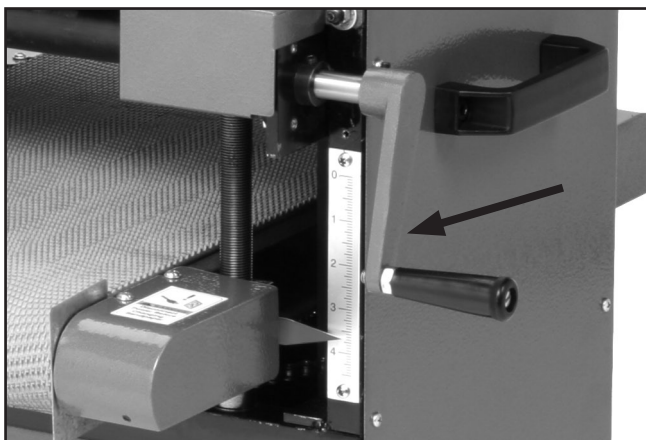

**Figure 9.** Setting depth of cut.

2. Turn the sander **ON**, start the conveyor (see **Variable Speed**, on this page), and feed the workpiece into the sander. SLOWLY raise the conveyor table until the workpiece makes light contact with the sanding drum. This is the correct height to begin sanding the workpiece.

# Variable Speed

The variable speed knob allows you to increase the feed rate from 0–15 FPM. The correct speed to use depends on the type of stock you are using (hardwood vs. softwood) and the stage of finish you are at with that workpiece.

As a general rule, a slower feed rate will sand the surface smoother, but runs the risk of burning the wood; a faster feed rate will remove material faster, but runs the risk of overloading the motor. Use trial-and-error to determine the best settings for your specific applications.

## To adjust the conveyor speed:

1. Start the conveyor.
2. Rotate the variable speed knob (**Figure 10**) clockwise to increase the feed speed, or counterclockwise to decrease the feed speed.



**Figure 10.** Variable speed knob.



# Sanding

## **WARNING**

**DO NOT sand more than one board at a time. Minor variations in thickness can cause one board to be propelled by the rapidly spinning sanding drum and ejected from the machine. NEVER stand directly in front of the outfeed area of the machine. Failure to do so could result in severe personal injury.**

### To sand a workpiece:

1. Adjust the table height according to the instructions in **Depth of Cut** on **Page 16**.
2. Start the dust collector, turn the sander **ON**, and start the conveyor.
3. Feed the workpiece through the sander. Retrieve the workpiece by standing at the side—not at the outfeed end.
4. Run wide stock through two or three times without adjusting the table height. Turn the stock 180° between passes to ensure an even cut.

# Sanding Tips

- Replace the sandpaper with a higher grit to achieve a finer finish.
- Raise the table with a maximum of ¼ turn of the crank handle until the workpiece is the desired thickness.
- Reduce snipe when sanding more than one board of the same thickness by feeding them into the sander with the front end of the second board touching the back end of the first board.
- Feed boards into the sander at different points on the conveyor to maximize sandpaper life and prevent uneven conveyor belt wear.
- DO NOT sand boards less than 8" long or less than 1/8" thick to prevent damage to the workpiece and the drum sander.
- Extend the life of the sandpaper by regularly using a PRO-STICK® sanding pad (**Page 19**).
- When sanding workpieces with irregular surfaces, such as cabinet doors, take very light sanding passes to prevent gouges. When the drum moves from sanding a wide surface to sanding a narrow surface, the load on the motor will be reduced, and the drum will speed up, causing a gouge.
- DO NOT edge sand boards. This can cause boards to kickback, causing serious personal injury. Edge sanding boards also can cause damage to the conveyor belt and sandpaper.
- When sanding workpieces with a bow or crown, place the high point up (prevents the workpiece from rocking) and take very light passes.
- Feed the workpiece at an angle to maximize stock removal and sandpaper effectiveness, but feed the workpiece straight to reduce sandpaper grit scratches for the finish passes.



# Choosing Sandpaper

There are many types of sanding belts to choose from. We recommend Aluminum Oxide for general workshop environments. Below is a chart that groups abrasives into different classes, and shows which grits fall into each class.

Grit	Class	Usage
36	Extra Coarse	Rough sawn boards, thickness sanding, and glue removal.
60	Coarse	Thickness sanding and glue removal.
80–100	Medium	Removing planer marks and initial finish sanding.
120–180	Fine	Finish sanding.

The general rule of thumb is to sand a workpiece with progressively higher grit numbers, with no one grit increase of more than 50. Avoid skipping grits; the larger the grit increase, the harder it will be to remove the scratches from the previous grit.

Ultimately, the type of wood you use and your stage of finish will determine the best grit types to install on your sander.

## Paper Replacement

The Model G0459 is designed for 3" wide hook-and-loop sandpaper rolls.

### To change sandpaper on the G0459:

1. **Disconnect the sander from the power source!**
2. Open the top cover to expose the drum.
3. Unwind the old sandpaper and notice the direction that it was wrapped around the drum.

4. Use the old sandpaper as a pattern to cut out the new sandpaper, or use the pattern in **Figure 11**, to cut the sandpaper to the necessary shape.

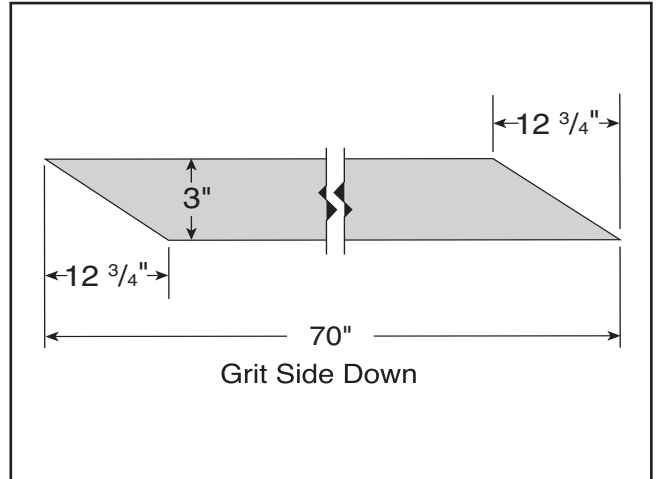

**Figure 11.** Sandpaper pattern.

5. Wrap the sanding drum with the new sandpaper. Make sure to wrap the sandpaper tight and try to keep the gaps to a minimum.
6. Tape both ends with 3/4" strapping tape (**Figure 12**), making at least two complete passes so that the second layer is directly on top of the first.

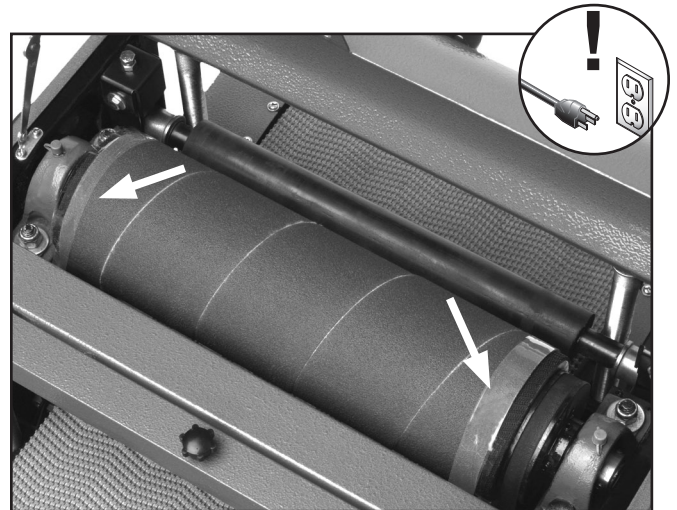

**Figure 12.** Sandpaper ends taped on Model G0459.



# SECTION 5: ACCESSORIES

## Aluminum Oxide Sanding Rolls, 3" x 50'

**H4422—60 Grit:** Use for thickness sanding and glue removal.

**H4779—80 Grit:** Use for removing planer marks and initial finish sanding.

**H4423—100 Grit:** Use for removing planer marks and initial finish sanding.

**H4780—120 Grit:** Use for finish sanding.

**H4424—150 Grit:** Use for finish sanding.

## H2499—Small Half-Mask Respirator

## H3631—Medium Half-Mask Respirator

## H3632—Large Half-Mask Respirator

## H3635—Disposable Cartridge Filter Pair P100

Wood dust is now considered a known carcinogen and has been linked to nasal cancer and severe respiratory illnesses. If you work around dust everyday, a half-mask respirator can be a lifesaver. Also compatible with safety glasses!



**Figure 13.** Half-mask respirator and disposable cartridge filters.

## PRO-STICK® Sanding Pad

Extend the life of your sandpaper! Just feed this crepe-rubber cleaning pad through your drum sander to remove dust build-up from the sandpaper without damage.

### Size

12" X 15" X 3/4"

### Model

H7331

**Call 1-800-523-4777 To Order**

## G7984—Face Shield

## H1298—Dust Sealed Safety Glasses

## H1300—UV Blocking, Clear Safety Glasses

## H2347—Uvex® Spitfire Safety Glasses

## H0736—Shop Fox® Safety Glasses

Safety Glasses are essential to every shop. If you already have a pair, buy extras for visitors or employees. You can't be too careful when it comes to shop safety!

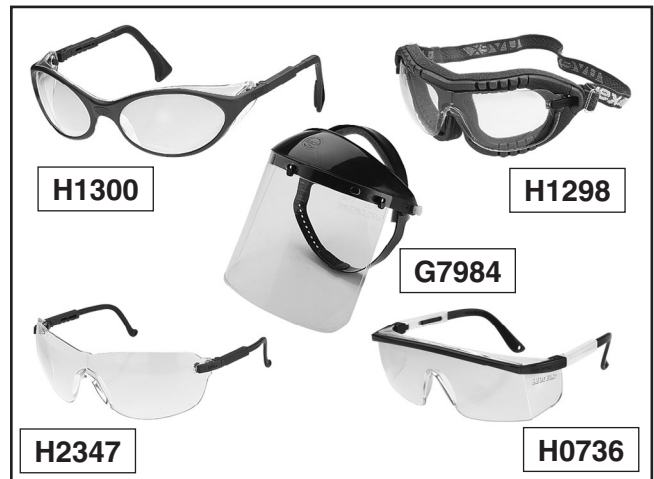

**Figure 14.** Our most popular safety glasses.

## G3640—Power Twist® V-Belt - 1/2" x 48"

Smooth running with less vibration and noise than solid belts. The Power Twist® V-belt can be customized in minutes to any size—just add or remove sections to fit your needs. Size: 1/2" x 48". Requires one Power Twist® V-belt to replace the stock V-belt on your Model G0459.

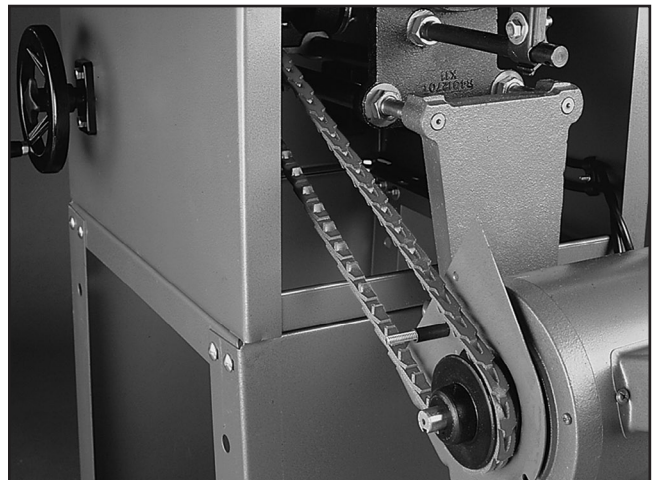

**Figure 15.** G3640 Power Twist® V-Belt.



**G3119—4" x 2½" Adapter**

Made with Anti-Static Additive! Made in USA.

**G3124—Wire Hose Clamps - 2½"**

**G3123—Flexible Hose - 2½" x 10'**

Everything you need to hook your sander up to a dust collector.



**Figure 16.** Model G3123 Flexible Hose.

**G1163—1HP Dust Collector**

Effective dust collection not only keeps your shop cleaner and more pleasant to work in, it can also keep you healthier. 1HP motor, 450 CFM, 2 cubic feet bag capacity, 13½" x 24" bag size, and 4" intake hole make this a great companion to your new sander!



**Figure 17.** Model G1163 Dust Collector.

**G7313—Tool Table**

Get that bench-top tool off your bench and put it on this sturdy **SHOP FOX®** stand instead! Flared legs and adjustable rubber feet ensure stability and reduce machine vibration. Butcher block finish table top measures 13" x 23" and is 30½" from the floor. Bottom measures 32" x 22". 700 lb. capacity. Perfect for the G0459!



**Figure 18.** Model G7313 Tool Table.

**G0572—Hanging Air Filter with Remote**

This Hanging Air Filter has a convenient remote control and features a three speed motor, automatic shutoff timer and 1 micron inner filter and 5 micron outer filter. Air flow is 556, 702 and 1044 CFM. Overall size is 26"L x 19½"W x 15"H. Batteries for remote not included. Approximate shipping weight 60 lbs.

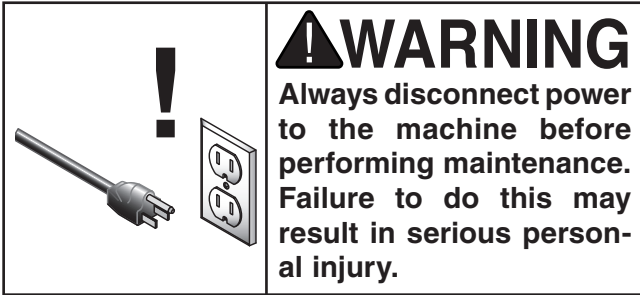

**Figure 19.** Model G0572 Hanging Air Filter with Remote.

**Call 1-800-523-4777 To Order**



# SECTION 6: MAINTENANCE



## Schedule

For optimum performance from your machine, follow this maintenance schedule and refer to any specific instructions given in this section.

### Daily Check:

- Loose mounting bolts.
- Worn switch.
- Worn or damaged cords or plugs.
- Damaged V-belt.
- Any other unsafe condition.

### ! WARNING

**DO NOT** attempt to investigate or adjust any features of the machine while it is running. Wait until the machine is turned **OFF**, unplugged, and all working parts have come to a rest before you do anything!

## Cleaning

Cleaning the Model G0459 is relatively easy. From time to time, vacuum wood dust off of the internal components, especially the motor.

## Lubrication

The chain should be lubricated periodically with a light machine oil. Motor bearings need no lubrication. Use only adequate lubrication. Too much lubricant will attract dirt and sawdust and will clog the chain mechanism.

**Pillow Block Bearing:** Must be lubricated every 20 hours of operation. Use a high-quality, lithium-based grease. A grease fitting (**Figure 20**) is located on the top of each pillow block bearing.

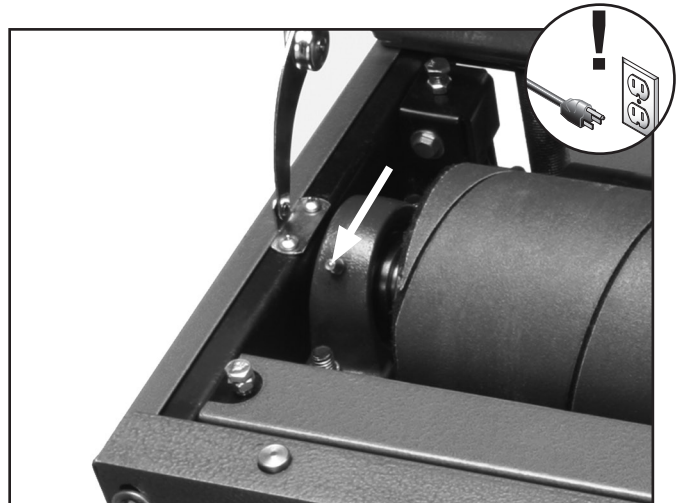
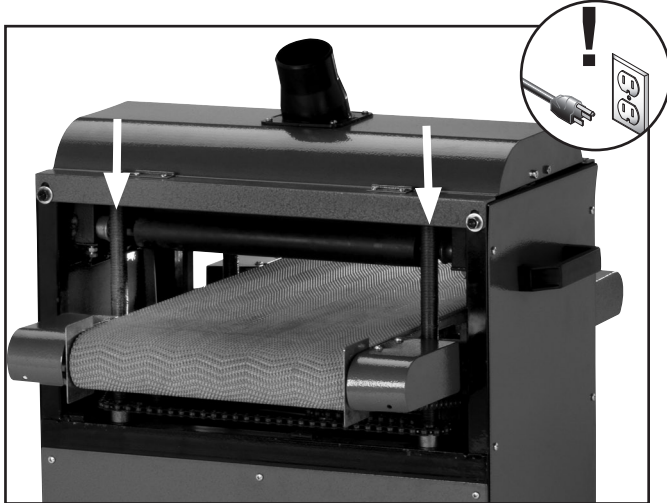

**Figure 20.** Location to lubricate pillow block bearing.



**Table Lift Screws:** These should be lubricated with lithium grease every six months.

Clean the table lift screws (**Figure 21**) and rub lithium grease onto the threads. Move the table up or down to spread the grease thoroughly over the threads.



**Figure 21.** Table lift screws.

## **!WARNING**

**Failure to routinely inspect your drum sander for damage and wear could result in unsatisfactory work results, premature component or machinery failure, or operator injury. We recommend you create a checklist for routine inspection and maintenance. Remember to always disconnect the drum sander from its power source before attempting to inspect, adjust, or repair this machine!**





# SECTION 7: SERVICE

This section is provided for your convenience—it is not a substitute for the Grizzly Service Department. If you need help troubleshooting, you need replacement parts, or you are unsure of how to perform the procedures in this section, then feel free to call our Technical Support at (570) 546-9663.

## Troubleshooting

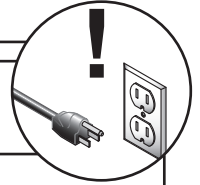

### Motor & Electrical

Symptom	Possible Cause	Possible Solution
Machine does not start or a breaker trips.	<ol style="list-style-type: none"> <li>1. Plug or receptacle is at fault or wired incorrectly.</li> <li>2. Start capacitor is faulty.</li> <li>3. Motor connection is wired incorrectly.</li> <li>4. Power supply is faulty, or is switched OFF.</li> <li>5. Centrifugal Switch is at fault.</li> <li>6. Motor ON button or ON/OFF switch is faulty.</li> <li>7. Motor is at fault.</li> </ol>	<ol style="list-style-type: none"> <li>1. Test power plug and receptacle for good contact and correct wiring.</li> <li>2. Test and replace capacitor as required (see photo, <b>Page 39</b>).</li> <li>3. Correct motor wiring (see <b>Page 40</b>).</li> <li>4. Make sure all hot lines and grounds are operational and have correct voltage on all legs.</li> <li>5. Adjust or replace the centrifugal switch.</li> <li>6. Replace faulty ON button or ON/OFF switch (see photo, <b>Page 39</b>).</li> <li>7. Test, repair or replace motor.</li> </ol>
Machine has vibration or noisy operation.	<ol style="list-style-type: none"> <li>1. Motor or component is loose.</li> <li>2. Motor fan is rubbing on fan cover.</li> <li>3. V-belt(s) is worn or is loose.</li> <li>4. Pulley is loose.</li> <li>5. Motor bearings are at fault.</li> <li>6. Centrifugal switch.</li> </ol>	<ol style="list-style-type: none"> <li>1. Inspect, replace for stripped or damaged bolts/nuts, and re-tighten with thread locking fluid.</li> <li>2. Replace dented fan cover, and replace loose or damaged fan.</li> <li>3. Inspect belt(s), replace as matched sets, and re-tension.</li> <li>4. Remove pulley, replace shaft, pulley, setscrew, and key as required, and realign.</li> <li>5. Check bearings, replace motor or bearings as required.</li> <li>6. Normal snap/click sound on RPM wind down. No problem exists.</li> </ol>
Motor overheats.	<ol style="list-style-type: none"> <li>1. Motor overloaded.</li> <li>2. Air circulation through the motor restricted.</li> </ol>	<ol style="list-style-type: none"> <li>1. Reduce load on motor.</li> <li>2. Clean off motor to provide normal air circulation.</li> </ol>



## Sanding Operations

Symptom	Possible Cause	Possible Solution
Machine stalls or is underpowered.	<ol style="list-style-type: none"> <li>1. Dust collection ducting is at fault.</li> <li>2. Low power supply voltage.</li> <li>3. Belt is slipping.</li> <li>4. Motor connection is wired incorrectly.</li> <li>5. Plug or receptacle is at fault.</li> <li>6. Pulley or sprocket is slipping on shaft.</li> <li>7. Motor bearings are at fault.</li> <li>8. Machine is undersized for the task.</li> <li>9. Motor has overheated.</li> <li>10. Centrifugal switch is at fault.</li> <li>11. Motor is at fault.</li> </ol>	<ol style="list-style-type: none"> <li>1. Seal all leaks, size ducts correctly, eliminate bends, and refer to Dust Collection Basics Handbook (ISBN 0-9635821-2-7) for further recommendations.</li> <li>2. Make sure all hot lines and grounds are operational and have correct voltage on all legs.</li> <li>3. Replace bad belt, align pulleys, and re-tension.</li> <li>4. Correct motor wiring (see <b>Page 40</b>).</li> <li>5. Test power plug and receptacle for good contact and correct wiring.</li> <li>6. Replace loose pulley and shaft.</li> <li>7. Rotate motor shaft for noisy or burnt bearings, repair/replace as required.</li> <li>8. Use new sandpaper with appropriate grit, and reduce the feed rate/depth of sanding.</li> <li>9. Unobstructed motor cooling air flow, let motor cool, and reduce workload on machine.</li> <li>10. Adjust or replace the centrifugal switch.</li> <li>11. Test, repair or replace motor.</li> </ol>
Machine lacks power; drum stops turning under load.	<ol style="list-style-type: none"> <li>1. V-belt loose.</li> <li>2. Too much pressure on pressure rollers.</li> </ol>	<ol style="list-style-type: none"> <li>1. Tighten V-belt (<b>Page 26</b>).</li> <li>2. Reduce pressure roller pressure (<b>Page 31</b>).</li> </ol>
Machine slows when sanding, making a squealing noise, especially on start-up.	<ol style="list-style-type: none"> <li>1. V-belt loose.</li> <li>2. V-belt worn out.</li> </ol>	<ol style="list-style-type: none"> <li>1. Tighten V-belt (<b>Page 26</b>).</li> <li>2. Replace V-belt (<b>Page 27</b>).</li> </ol>
Loud repetitious noise coming from machine.	<ol style="list-style-type: none"> <li>1. Pulley setscrews or keys are missing or loose.</li> <li>2. Motor fan is hitting the cover.</li> <li>3. V-belt is defective.</li> </ol>	<ol style="list-style-type: none"> <li>1. Inspect keys and setscrews. Replace or tighten if necessary.</li> <li>2. Adjust fan cover mounting position, tighten fan, or shim fan cover.</li> <li>3. Replace V-belt (<b>Page 27</b>).</li> </ol>
Vibration when sanding.	<ol style="list-style-type: none"> <li>1. Loose drum pillow block bearings.</li> <li>2. Worn drum pillow block bearings.</li> </ol>	<ol style="list-style-type: none"> <li>1. Tighten drum pillow block bearings.</li> <li>2. Replace drum pillow block bearings.</li> </ol>
Grinding, screeching, or rubbing noise when sanding drum is powered up.	<ol style="list-style-type: none"> <li>1. Drum bearings lack sufficient grease.</li> <li>2. Drum bearings are worn and need replacement.</li> </ol>	<ol style="list-style-type: none"> <li>1. Grease the pillow block bearings (<b>Page 21</b>).</li> <li>2. Replace the drum bearings.</li> </ol>

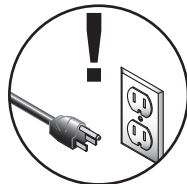

Symptom	Possible Cause	Possible Solution
Short V-belt lifespan.	1. Pulleys not aligned correctly. 2. Improperly tensioned.	1. Align pulleys ( <b>Page 27</b> ). 2. Properly tension V-belts ( <b>Page 26</b> ).
Conveyor slips under load.	1. Conveyor is too loose. 2. Too much load.	1. Tension conveyor ( <b>Page 28</b> ). 2. Decrease load.
Conveyor tracks to one side; conveyor hits the roller cover.	1. Conveyor tracking is incorrect.	1. Track the conveyor so it runs straight ( <b>Page 28</b> ).
Workpiece pulls to one side during sanding operations.	1. The sanding drum is not parallel with the table.	1. Adjust the sanding drum parallel to the table ( <b>Page 29</b> ).
Excessive snipe.	1. Too much pressure from all the pressure rollers. 2. Too much pressure from the rear pressure roller. 3. Lack of outfeed support.	1. Reduce pressure roller pressure ( <b>Page 31</b> ). 2. Reduce rear pressure roller pressure ( <b>Page 31</b> ). 3. Set up outfeed table or have someone catch the workpiece as it comes out.
Workpiece kicks out of sander.	1. Not enough pressure from the pressure rollers.	1. Increase pressure roller pressure ( <b>Page 31</b> ).
Sandpaper tears off drums during operation.	1. Nail/staple in workpiece. 2. Sandpaper not tightened or fastened correctly. 3. Drum not perpendicular to the feed direction.	1. Sand only clean workpieces. 2. Install the sandpaper correctly ( <b>Page 18</b> ). 3. Adjust the drum perpendicular to the feed direction ( <b>Page 29</b> ).
Table elevation controls are stiff and hard to adjust.	1. Table lift screws are dirty or loaded with sawdust.	1. Clean and regrease table lift screws ( <b>Page 22</b> ).
Poor dust collection.	1. Dust collection lines incorrectly sized for this machine. 2. Dust collector underpowered or too far away from this machine.	1. Use at least an 8" main line with two 6" branch lines that each Y into 2½" at the machine. 2. Upgrade your dust collector or decrease the distance from the dust collector to the machine.
Grease on conveyor belt	1. Chain too low.	1. Raise table far enough up so it doesn't touch chain.

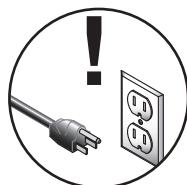

# Gauge Blocks

Tools Needed:	Qty
6' Long 2x4.....	1
Miter Saw (or Circular Saw) .....	1
Jointer.....	1
Table Saw .....	1

The gauge blocks described here will be required to complete most of the service procedures in this section.

## To make the gauge blocks:

1. Edge joint the concave edge of the 2x4 flat on a jointer, as shown in **Figure 22**.

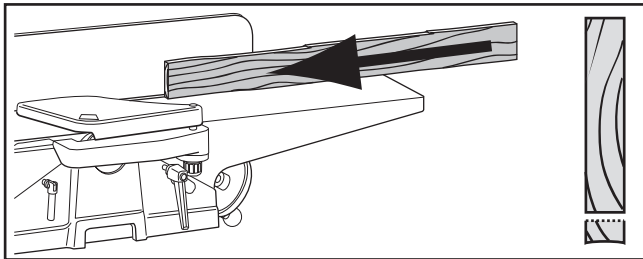

**Figure 22.** Edge jointing on a jointer.

2. Place the jointed edge of the 2x4 against the table saw fence and rip cut just enough off the opposite side to square up the two edges of the 2x4, as shown in **Figure 23**.

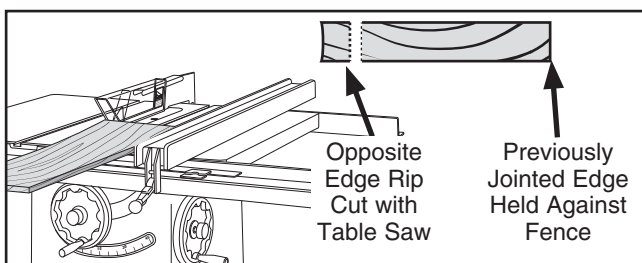

**Figure 23.** Rip cutting on a table saw.

3. Cut the 2x4 into two even pieces to make two 36" long wood gauge blocks.

**Note:** *Steps 1 & 2 can be skipped, but having these wood gauge blocks at an even height is critical to the accuracy of your overall adjustments.*

# V-Belt Service

Tools Needed:	Qty
Hex Wrench 6mm.....	1
Wrench 12mm .....	1
Straightedge .....	1
Ruler.....	1
Phillips Head Screwdriver #2 .....	1

## Tension

A new V-belt often stretches and loosens up during the first 16 hours of use. After this period, it should be inspected and re-tensioned if necessary.

Proper tension is important for optimum power transmission. However, too much tension may cause premature bearing failure.

## To test V-belt tension:

1. Remove the right handle and side panel.
2. Using a straightedge and ruler (**Figure 24**), push on the middle of the V-belt. The correct V-belt tension is achieved when the V-belt can be deflected  $\frac{1}{2}$ "– $\frac{3}{4}$ " with moderate pressure.

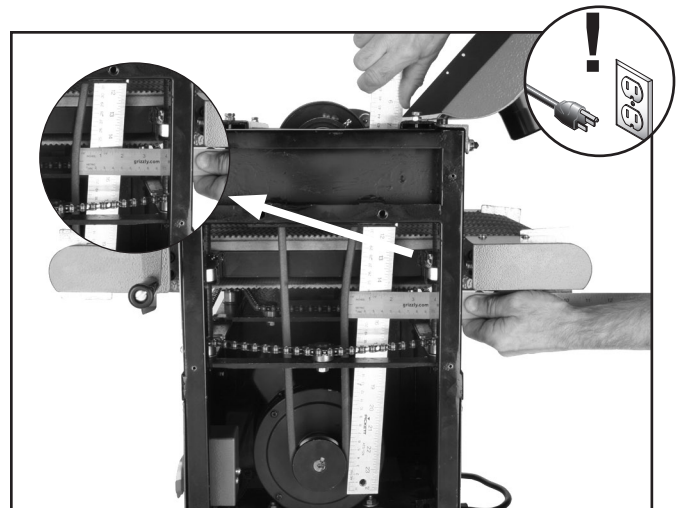

**Figure 24.** Checking V-belt tension with a straightedge and a ruler.

3. Reinstall the side panel and handle.



### To adjust V-belt tension:

1. DISCONNECT POWER TO THE SANDER!
2. Open the rear panel.
3. Loosen the motor mount bolts and raise or lower the motor bracket, as shown in **Figure 25**, to loosen or tighten the V-belt.
4. Tighten the motor mount bolts and replace the rear panel.

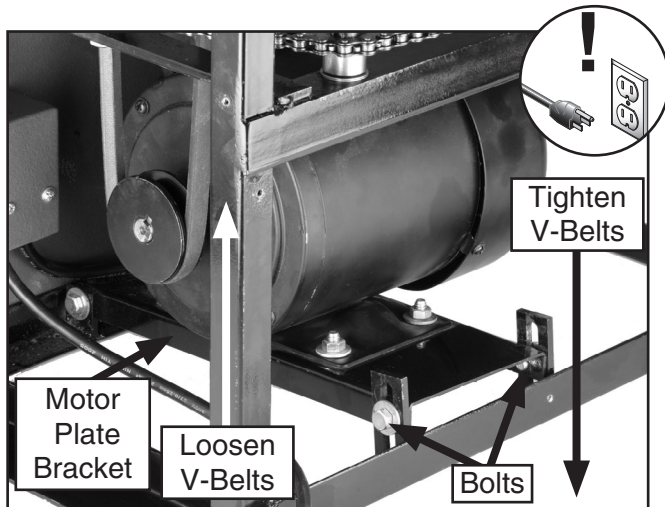

**Figure 25.** V-belt tension controls.

### Removal/Replacement

Replace the V-belt if you notice fraying, cracking, glazing, or any other damage. A worn/damaged V-belt will not provide optimum power transmission from the motor to the drums.

V-belt removal and replacement is simply a matter of loosening the V-belt, rolling it off of the pulleys, replacing it, and re-tensioning it.

### Pulley Alignment

Pulley alignment is another important factor in power transmission and belt life. The pulleys should be parallel to each other and in the same plane (coplanar) for optimum performance.

Each pulley can be adjusted by loosening the set screws that secure the pulley to the shaft, sliding the pulley in/out, and retightening the set screws to lock the pulley in place.

### To align the pulleys:

1. DISCONNECT POWER TO THE SANDER!
2. Remove the right handle and side panel.
3. Remove the V-belt.
4. Place a straightedge across the face of the motor pulley and drum pulley to check the alignment. The straightedge should sit evenly on the top and bottom part of both pulleys, as shown in **Figure 26**.

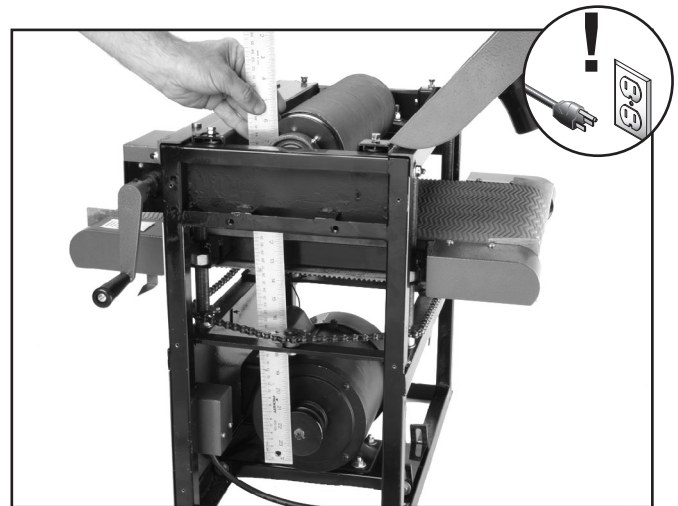

**Figure 26.** Checking pulley alignment with a straightedge.

5. Adjust the pulleys as necessary until they are all coplanar with each other.
6. Reinstall the side panel and handle.



# Conveyor Tensioning & Tracking

Tools Needed:	Qty
Wrench 19mm .....	1
Phillips Head Screwdriver #2 .....	1

## Tensioning

The conveyor may slightly stretch with continued use and will eventually need to be tensioned. This is most obvious if the conveyor starts slipping on the rollers.

When you tension the conveyor, focus on tensioning the adjustment bolts in even increments. Tensioning one side more than the other will cause tracking problems, which will require you to take additional steps to get the sander operating correctly.

### To tension the conveyor:

1. Use a magic marker, correction fluid, or fingernail polish to mark the front of the conveyor tensioning bolt on both sides (**Figure 27**). This step will aid you in keeping track of the rotations as you turn the bolts, so they remain as even as possible.

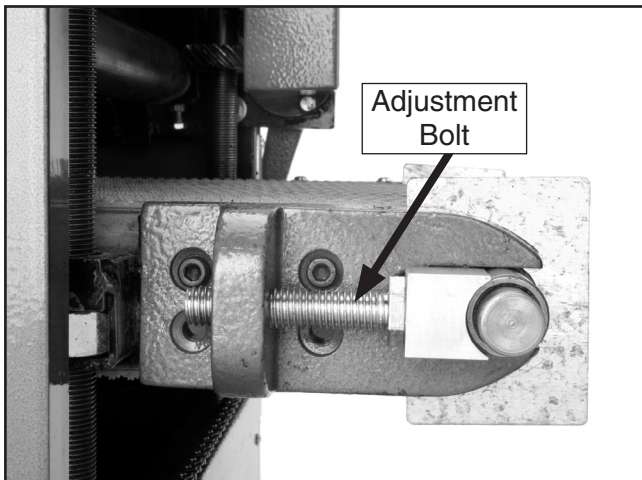

**Figure 27.** One side of conveyor tensioning & tracking controls (guard removed for clarity).

**Note:** Removing the front right and left roller guard covers makes it easier to access the adjustment bolts. Be sure to reinstall the guards when adjustments are complete.

2. Turn both of the conveyor adjustment bolts counterclockwise one full turn at a time until the conveyor belt no longer slips during operation.

—If the conveyor starts tracking to one side, immediately turn the drum sander **OFF** and perform the tracking instructions.

## Tracking

The conveyor must track straight. If the conveyor tracks to either side, then the tracking must be corrected or the conveyor will become damaged and have to be replaced.

Replacing a damaged conveyor is a big job. Always be careful to make sure that the belt does not travel too far to one side or the other.

Tracking the conveyor is a balancing process that takes patience and a small degree of trial-and-error. Usually you must over-tighten the loose side (the side the belt is tracking towards) to make the conveyor move to the middle of the rollers, then loosen that same side to make the conveyor stay in position. If you adjust the bolt too much either way, then you have to repeat the process until the conveyor rides in the middle and stays there during continuous operation.

### To track the conveyor:

1. Turn the conveyor **ON** and watch it track.
2. Determine which side the conveyor is tracking towards (the loose side) and tension the adjustment bolt on that side until the conveyor tracks in the opposite direction.

**Note:** Tracking changes may take up to three minutes before they are noticeable.

3. When the conveyor is near the middle of the rollers or table, loosen the adjustment bolt until the conveyor stops moving and tracks straight.

—If the conveyor tracks too far to the other side, then adjust the bolt as necessary to bring it back and repeat **Steps 2 & 3** until the tracking is correct.



# Drum Adjustments

Tools Needed:	Qty
Hex Wrench 4mm.....	1
Wrench 19mm.....	1
Wrench 10mm.....	1
Socket 14mm.....	1
Measuring Tape.....	1
Gauge Blocks (see <b>Page 26</b> ).....	2
Feeler Gauge Set.....	1

For the Model G0459 Drum Sander to function properly, the sanding drum must be aligned in two directions: (1) parallel to the conveyor belt and (2) perpendicular to feed direction.

The drums can be adjusted in fine increments at the pillow block bearings and in larger increments by using the table lift screws (**Page 33**).

While adjusting the drum, keep in mind that having the drum parallel to the conveyor belt is critical to the sanding operation. Care should be taken to make the tolerances as close as possible (within 0.002" from one side to the other) when adjusting the drum height.

The tolerances for having the drum perpendicular to the feed direction are much more forgiving, even allowing up to 1/8" difference from one side to the other before causing problems.

**To align the sanding drum parallel to the conveyor belt (Figure 28):**

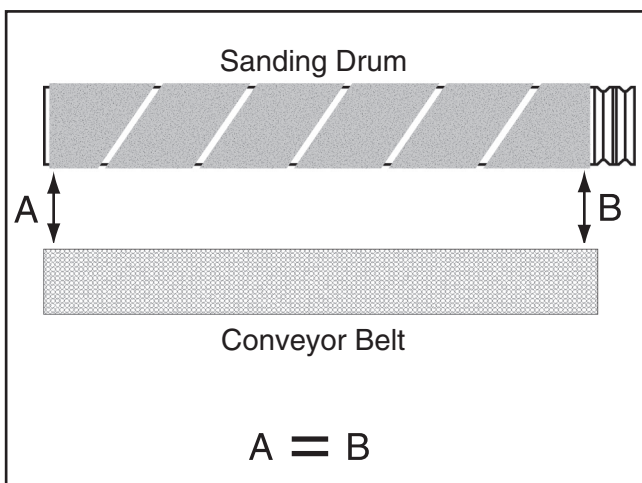

**Figure 28.** Drum parallel to conveyor belt.

1. DISCONNECT POWER TO THE SANDER!
2. Open the top cover.
3. Loosen the lock nuts (see **Figure 29**) on the drum pillow block bearing.

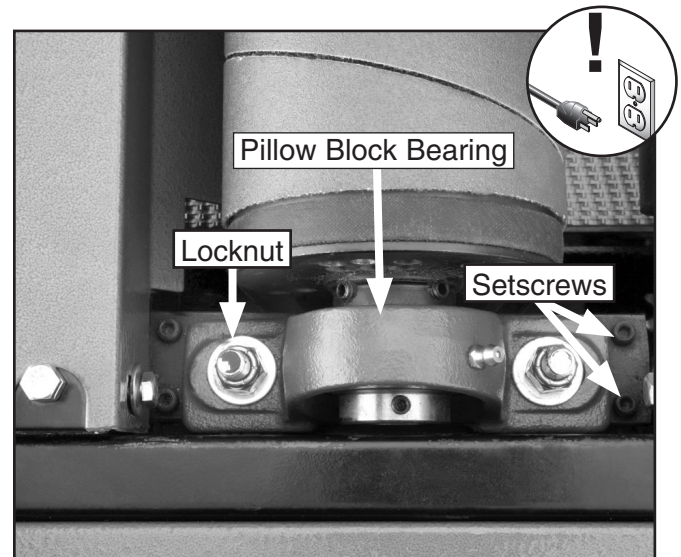

**Figure 29.** Pillow block bearing adjustments.

4. Place the gauge blocks on the conveyor table and position them under the pressure rollers, as shown in **Figure 30**.



**Figure 30.** Gauge blocks positioned under pressure rollers and sanding drum.

5. Raise the table until the gauge blocks just touch the bottom of the sanding drum.

**Note:** A good way to know when they are touching is to rock the sanding drum back and forth while raising the table until you hear or feel contact with the gauge blocks.



6. Lower the table one full turn of the crank handle. Wait until the chain starts moving before starting to count the crank handle rotation.
7. Starting at one end, place a 0.002" feeler gauge between the sanding drum and the gauge block. (The feeler gauge should slide with moderate resistance, without forcing the drum to roll.)
8. Repeat **Step 7** at the other end of the drum.

—If the difference between the two sides is 0.002" or less, skip to the subsection that covers how to adjust the sanding drum perpendicular to the feed direction on this page.

—If the difference between the two sides is more than 0.002", then one side must be adjusted to within 0.002" of the other (with the ultimate goal of making them dead even). Continue to the next step.

#### To adjust the pillow block bearings:

1. Loosen the lock nuts (see **Figure 29**) on one of the pillow block bearings that requires adjustment.
2. Rotate the setscrews  $\frac{1}{8}$  of a turn clockwise to raise the pillow block bearings (see **Figure 29**).

**Note:** Turn all setscrew sets an equal amount.

3. Tighten the lock nuts and recheck the alignment using the gauge blocks, repeating **Steps 1–8** from the previous subsection. Tightening the lock nuts will pull the drum downward slightly. Be sure to adjust to compensate for this movement. **Do not over tighten the lock nuts. The pillow block bearings can break if over tightened.**

#### To adjust the sanding drum perpendicular to the feed direction (**Figure 31**):

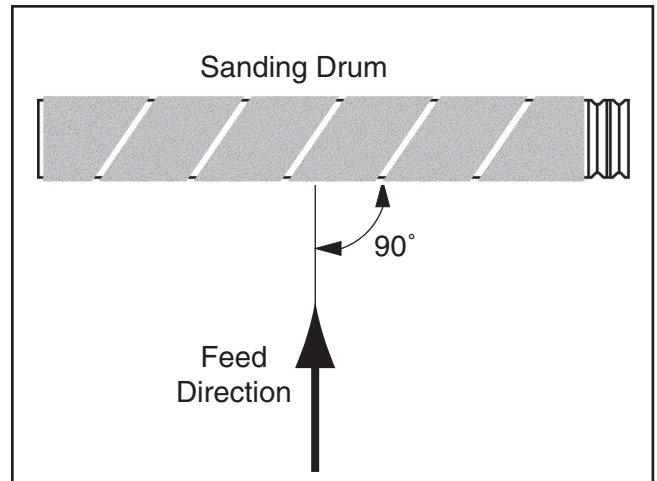

**Figure 31.** Drum perpendicular to feed direction.

1. DISCONNECT POWER TO THE SANDER!
2. First measure the distance between the outside of the drum and the inside of the dust scoop (**Figure 32**). The distances should be within  $\frac{1}{8}$ " of each other at each end of the drum.

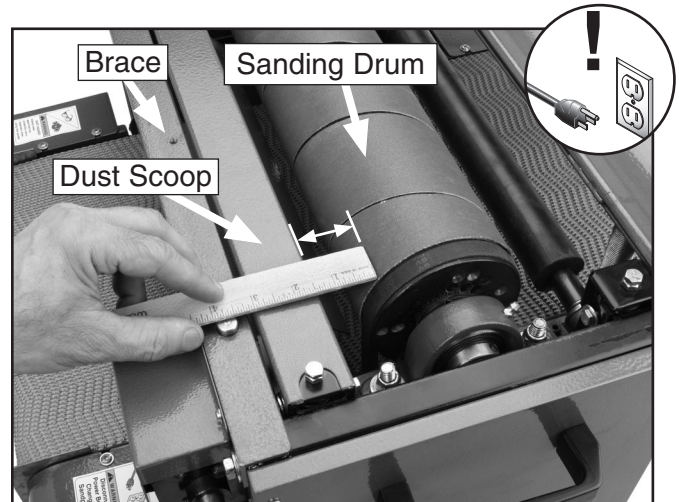

**Figure 32.** Measuring distance between drum and dust scoop.

3. If the measurements are not within  $\frac{1}{8}$ ", the drum can be moved by loosening the lock nuts on the pillow block bearings and moving one end of the drum forward or backward as necessary in the slotted holes.

**Note:** After you have adjusted the drum, do not forget to tighten the lock nuts and recheck the alignment by repeating **Steps 1–3**.





# Pressure Roller Height

Tools Needed:	Qty
Wrenches/Sockets 10mm .....	1
Gauge Blocks (see <b>Page 26</b> ) .....	2

## Factory Setting:

Distance Below Sanding Drum ..... 0.080" (2mm)

The pressure rollers are factory set at 0.080" (2mm) below the bottom of the sanding drum and are fully adjustable either up/down with the four lower adjustment bolts (**Figure 33**). After the adjustment has been made, always lock the jam nuts against the bottom to prevent them from moving.

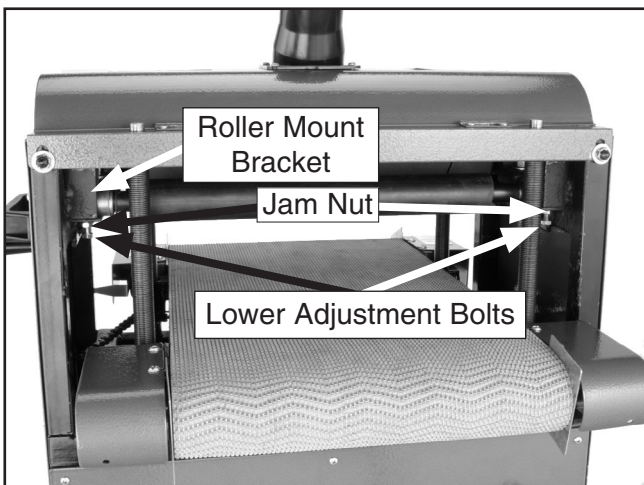

**Figure 33.** Pressure roller adjustment hex nuts.

Proper pressure on the workpiece helps avoid kickback and keeps the workpiece from slipping. However, as pressure increases on the workpiece, snipe also increases (some degree of snipe is normal with all drum sanders).

If snipe becomes a problem, you can minimize it by reducing pressure. To lower pressure, turn the lower adjustment bolts counterclockwise to raise the pressure roller height. To increase pressure, turn the lower adjustment bolts clockwise (lowering pressure rollers).

However, you can only minimize snipe so much before the workpiece will slip or kick out, causing a hazard to the operator. If this happens, you have raised the pressure rollers too high for them to function as intended—the pressure rollers **MUST** be lowered to prevent injury.

## **!WARNING**

**Raising the pressure rollers too high to minimize snipe will cause the workpiece to slip or kick out, causing a hazard to the operator. You **MUST** lower the pressure rollers to prevent injury!**

These instructions will restore the pressure rollers to the factory setting.

### To adjust the pressure rollers to the factory setting:

1. DISCONNECT POWER TO THE SANDER!
2. Open the top cover.
3. Place the gauge blocks on the conveyor table and position them under all the pressure rollers (**Figure 30**).
4. Raise the table so the gauge blocks touch the bottom of the sanding drum, as shown in **Figure 34**.

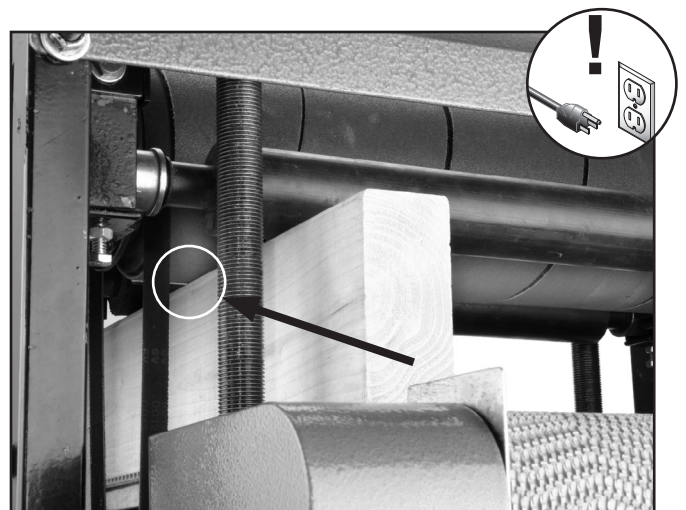

**Figure 34.** Gauge block touching bottom of sanding drum.



- Turn the crank handle three full rotations (counting from the point of actual table movement so handwheel freeplay does not affect your count) to lower the table so the gauge blocks are below the pressure rollers, as shown in **Figure 35**.

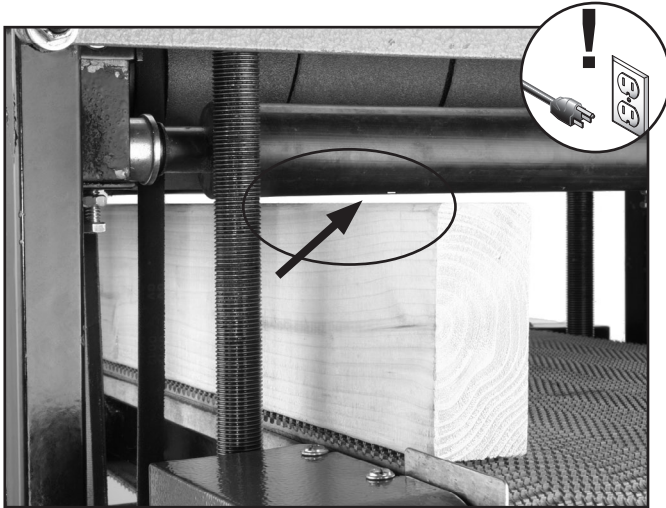

**Figure 35.** Gauge blocks below pressure rollers.

**Note:** You may open the side covers to gain better access for the following adjustments. This is not required.

- Turn a lower adjustment bolt on one side of a pressure roller clockwise to lower that end of the pressure roller until it touches the gauge block.
- Repeat **Step 6** for the opposite side of the same pressure roller.
- Repeat **Steps 6–7** with the second pressure roller. Each pressure roller should look like **Figure 36** when properly adjusted.

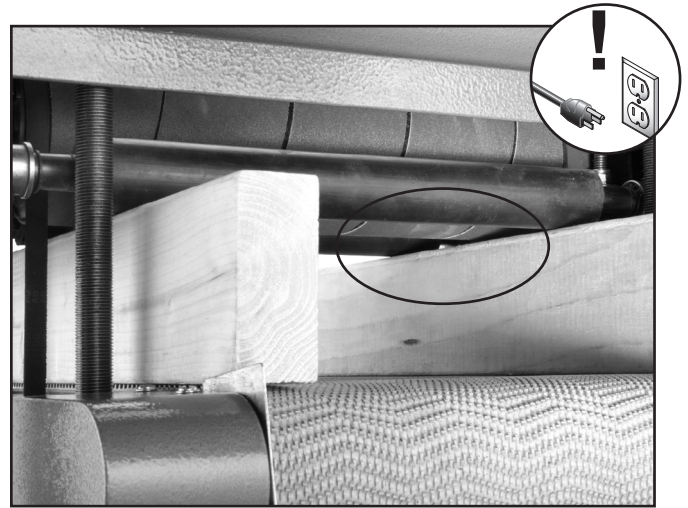

**Figure 36.** Pressure rollers set correct distance below bottom of sanding drum.

- Tighten the jam nuts (**Figure 33**) to lock the adjustment.

## Scale Pointer Calibration

Tools Needed:	Qty
Phillips Head Screwdriver .....	1

In order for the scale pointer to be accurate, it must be calibrated.

We recommend calibrating your scale pointer any time you adjust the drum height or table lift screws.

### To calibrate the scale pointer:

- Sand a workpiece with the drum sander and measure the thickness of the sanded workpiece.
- Loosen the screw that secures the scale pointer and adjust it to the thickness of the workpiece.



# Table Lift Screws

Tools Needed:	Qty
Hex Wrench 6mm.....	1
Wrench/Socket 12mm .....	1
Chalk, Correction Fluid, or Paint .....	1
Phillips Head Screwdriver #2 .....	1
Flat Head Screwdriver.....	1

The table lift screws are connected by a chain and driven by the crank handle. (When the chain is removed from a sprocket on one of the lift screws, that lift screw can adjust that portion of the table up/down independently to assist in setting the table parallel to the drum.)

Adjusting the table lift screws will only be necessary if you need to adjust the drum height more than allowed at the pillow block bearing adjustments, or if you have removed the table or chain (see **Page 37**) during a service procedure and you need to reset the drum parallel to the table.

Each complete tooth rotation on the sprocket represents 0.007" or .18mm of table elevation movement. For example, if the rear of the table was 0.007" low, rotate both rear table lift screws to the next sprocket tooth in the same chain position. You can easily rotate the sprockets from the top of the table lift screws with a flat head screwdriver.

## To adjust the table lift screws:

1. DISCONNECT POWER TO THE SANDER!
2. Open the right side and front panels.
3. Raise the table up to at least the 1" mark on the height scale.
4. At the lift screw that needs to be adjusted, mark the end of a sprocket tooth and the chain hole where that tooth is meshed, as shown in **Figure 37**.

## NOTICE

Marking the chain and sprocket locations will save you a substantial amount of time when you reinstall the chain. Make sure you have done this before removing the chain.

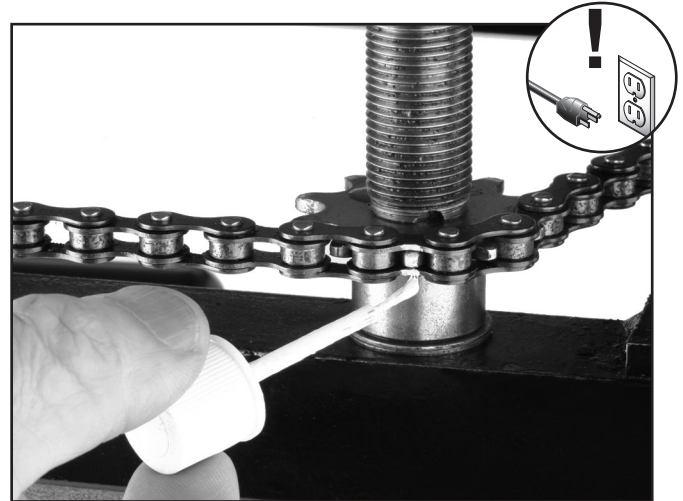

Figure 37. Marking sprocket tooth and chain.

5. Loosen the chain by loosening the hex nut on the bottom of the idler roller sprocket shown in **Figure 38**.

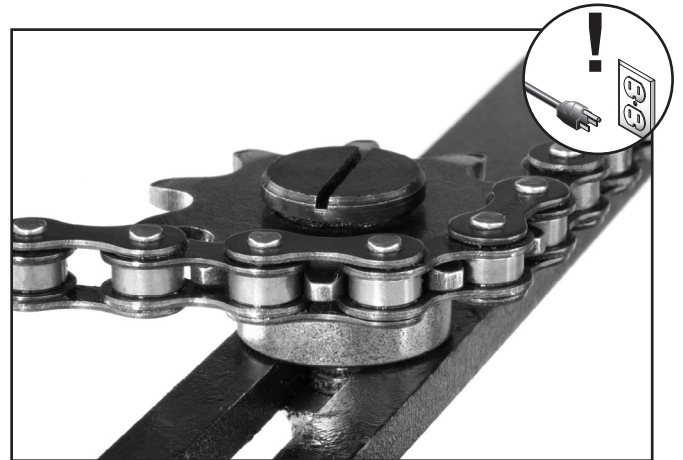

Figure 38. Idler roller sprocket.

6. Carefully move the chain off of only the marked sprocket.
7. Keep track of the marked chain hole and rotate the sprocket the necessary number of teeth away from the marked one to meet the difference in height needed.
8. Fit the chain back over the sprocket, making sure the new sprocket tooth is inserted into the marked chain hole.
9. Re-tension the chain and check the new height setting.
10. Repeat **Steps 5–9** as needed until the table height is parallel to the drums in all four corners, tighten the idler sprocket and calibrate the scale pointer.



# Conveyor Belt Replacement

Tools Needed:	Qty
Hex Wrench 6mm.....	1
Wrench/Socket 19mm.....	1
Wrenches/Socket 14mm.....	2
Wrench/Socket 12mm.....	1
Wrench 10mm.....	1
Phillips Head Screwdriver #2.....	1
Measuring Tape.....	1
Gauge Blocks (see <b>Page 26</b> ).....	2
Feeler Gauge Set.....	1
Assistant for Lifting Help.....	1
Flashlight or Work Light.....	1
Correction Fluid or Paint.....	1
Black Felt Tipped Pen.....	1

Replacing the conveyor belt is a big job and requires moderate mechanical skill and a fair amount of patience. For planning purposes, expect to have your machine out of operation for at least a few hours.

As you remove hardware to complete these instructions, we recommend putting all the bolts, screws, washers, etc. back into the holes from which they came. This simple habit will take slightly longer when disassembling the machine, but it will save you a lot of time and reduce frustration during reassembly.

## To replace the conveyor belt:

1. DISCONNECT POWER TO THE SANDER!
2. Remove the top cover by loosening the hex bolts and removing the Phillips head screws (**Figure 39**) securing the top cover support.

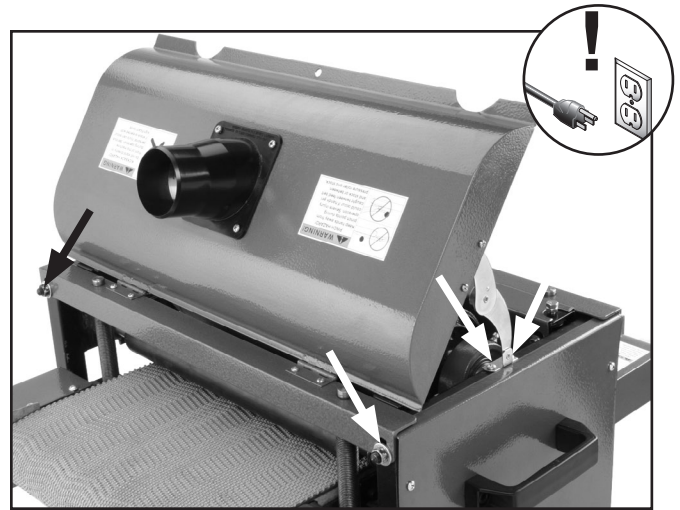

**Figure 39.** Locations to remove top cover mounting hardware.

3. Remove the right handle and side panel (2 cap screws and 6 tap screws).
4. Remove the gear cover (2 Phillips head screws) and loosen the 2 hex nuts securing the brace and remove it.
5. Remove the dust scoop (4 hex bolts and 4 flat washers), compression springs and spring plates (**Figure 40**) from the front pressure roller and set the roller aside.

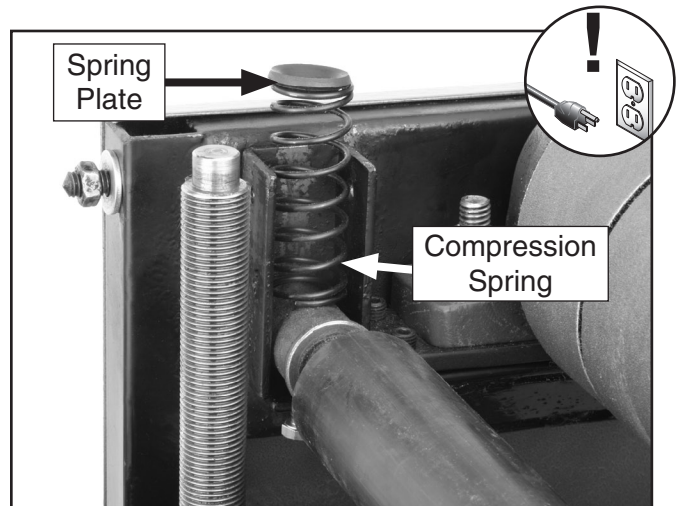

**Figure 40.** Front pressure roller components.



- Remove the rear pressure roller (4 hex bolts and 4 flat washers) along with the brackets, compression springs, and spring plates shown in **Figure 41**.

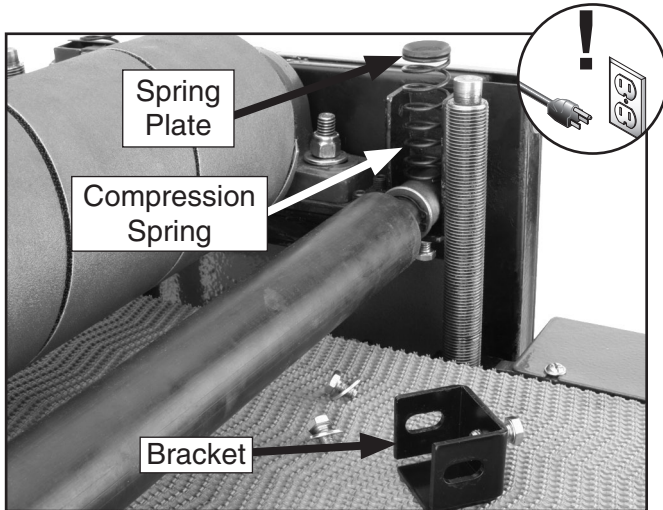

**Figure 41.** Rear pressure roller components.

- Remove the rear panel.
- Loosen the hex bolts securing the motor bracket to the frame, raise the motor and remove the V-belt from the motor pulley (see **Page 27** for help). The drum sander should now look similar to **Figure 42**.

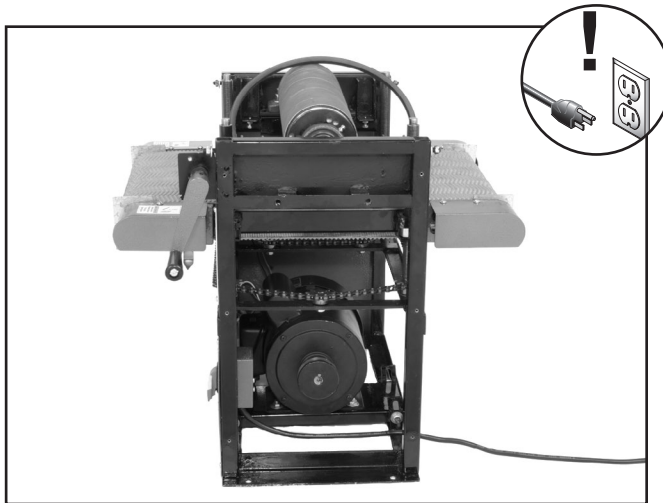

**Figure 42.** Drum sander disassembled to **Step 8**.

- Remove the sanding drum (4 lock nuts and 4 flat washers) and V-belt (**Figure 43**).

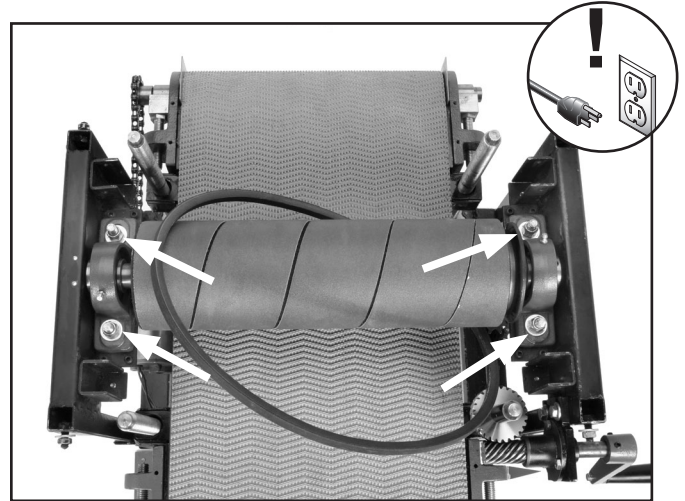

**Figure 43.** Location to remove sanding drum components.

- Remove the front roller end guard covers (4 Phillip head screws) and the rear roller end guard covers (4 Phillip head screws), and set the covers aside. The drum sander should now look similar to **Figure 44**.

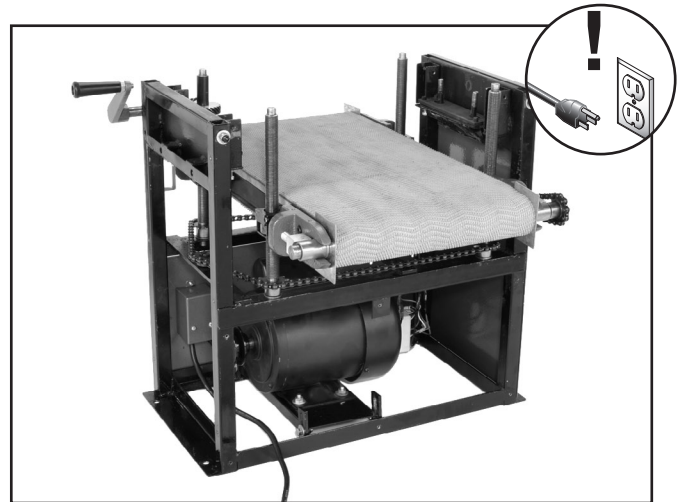

**Figure 44.** Drum sander disassembled to **Step 10**.



11. Mark the top of the table lift screws with arrows (all pointing in same direction) and mark the screws with liquid correction fluid above the mounting bracket (**Figure 45**). Later, when you reassemble the conveyor table, you can use these marks to reset the table height close to the current position.

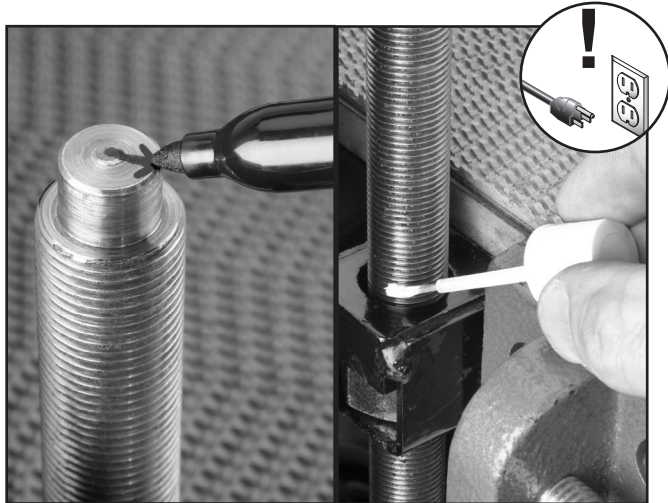

**Figure 45.** Locations to mark table lift screws.

12. Mark the chain and sprockets with correction fluid.
13. Loosen the idler roller sprocket (**Figure 38**), carefully pull the chain off of all the sprockets, and remove it from the cabinet.
14. Loosen the conveyor belt at the front adjustments, as shown in **Figure 46**.

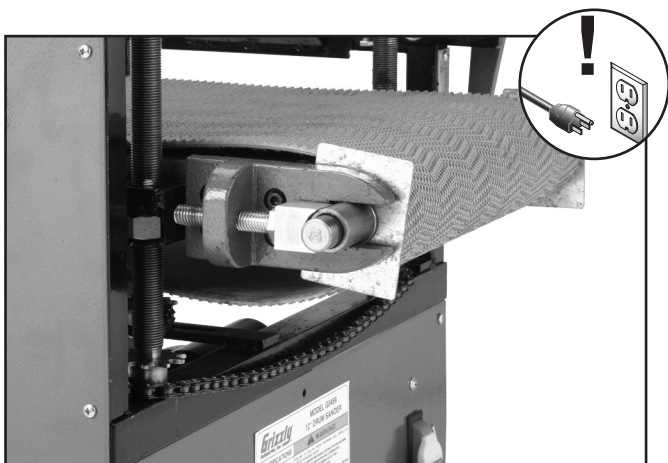

**Figure 46.** Conveyor belt loosened at the front adjustments (only one shown).

15. Disconnect the conveyor feed motor wires from the circuit board.
16. Remove the scale pointer.

*Before removing the table, note the number and location of brass shims (**Figure 47**) under the table lift screws. Knowing their correct position will help you align the conveyor table during reassembly.*

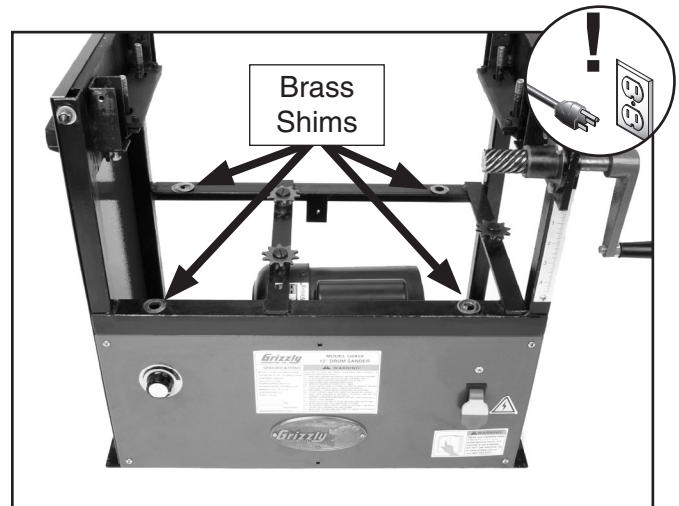

**Figure 47.** Brass shims.

17. With the help of an assistant, carefully lift the table off of the drum sander cabinet, as shown in **Figure 48**.

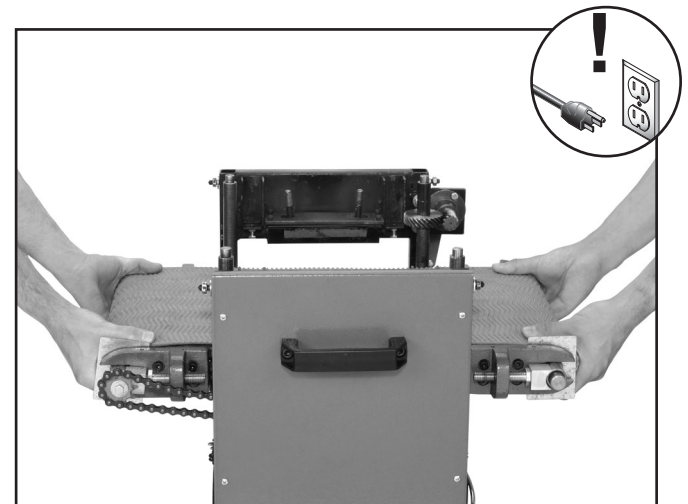

**Figure 48.** Lifting the table off of the drum sander cabinet with two people.



18. Lay the conveyor table on a flat surface.
19. Loosen the rear left (**Figure 49**) roller bracket (2 cap screws) enough so the conveyor motor chain is slack.

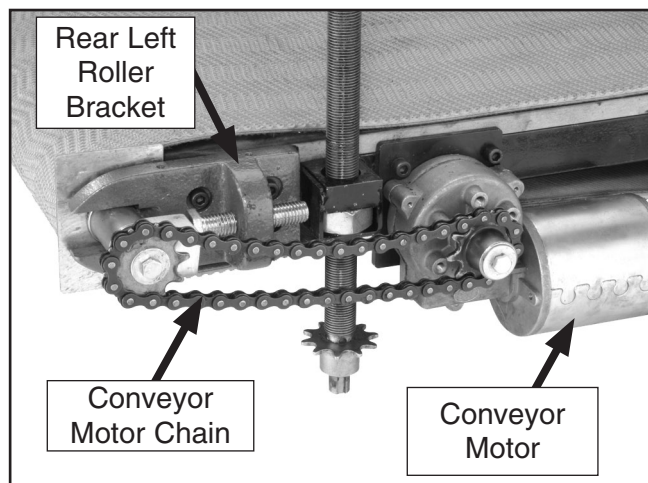

**Figure 49.** Rear left roller bracket loosened.

20. Remove the conveyor motor chain.
21. Remove the conveyor motor (2 cap screws) and the rear roller bracket (2 cap screws) shown in **Figure 49**.
22. Remove the rear roller.
23. Remove the front left roller bracket (2 cap screws) and the front roller.
24. Remove the front right and rear roller brackets (4 cap screws).
25. Place the right side of the conveyor on a flat surface, then unthread and remove the front and rear table lift screws.
26. Remove the belt. The table should look like **Figure 50**.

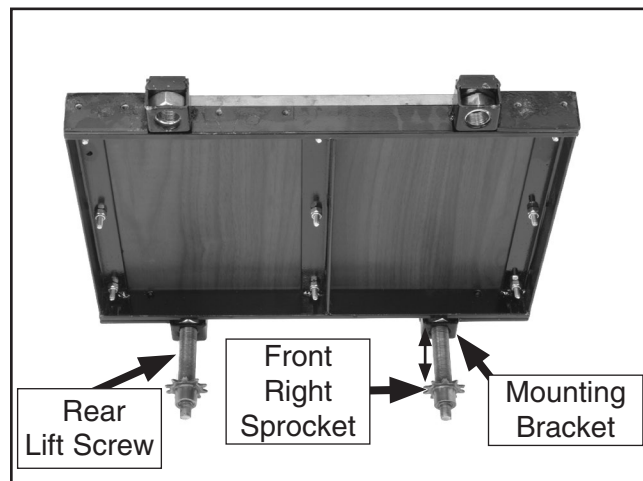

**Figure 50.** Conveyor belt removed from table.

27. Measure the distance between the front right table lift screw sprocket and the mounting bracket. If necessary, rotate the rear shaft so the sprocket-bracket distance is the same as the front right table lift screw.
28. Install the new belt.
29. Reinstall the front left and rear left table lift screws to match the front right lift screw height.
30. Reassemble the drum sander by reversing the disassembly steps.
31. After reassembly, adjust the drums and pressure rollers to their proper settings. See **Drum Adjustments** on **Page 29** and **Pressure Roller Height** on **Page 31**.
32. After you have reinstalled the conveyor table, make sure the four lower pressure roller adjustment bolts are threaded the same distance into the roller mount brackets (**Figure 33**).
33. After reinstalling the top cover and brace, tighten the mounting bolts.



- 34.** Before reinstalling the gear box cover, try raising and lowering the conveyor table with the crank handle. If the worm wheel and worm gear teeth (see **Figure 51**) are not engaged, the crank handle will only raise the table.

If this happens, loosen the crank handle mounting bolts, and move the worm gear around until the teeth mesh with the worm wheel, then secure the crank handle.

- 35.** Reinstall and secure the brace.
- 36.** Try moving the conveyor table up and down.
- 37.** Continue adjusting the worm wheel and worm gear until the crank handle raises and lowers the conveyor table.

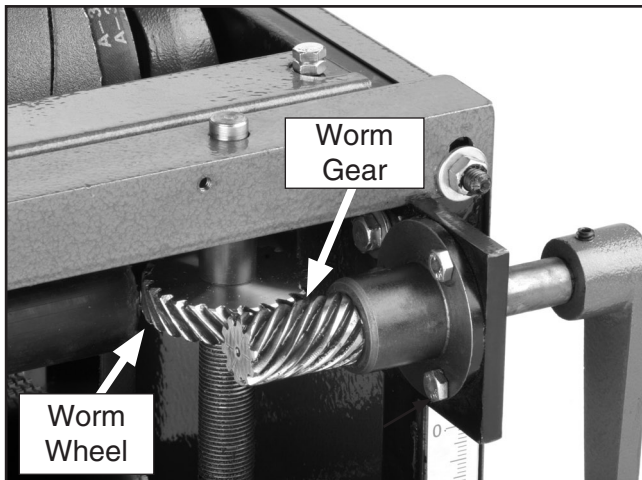
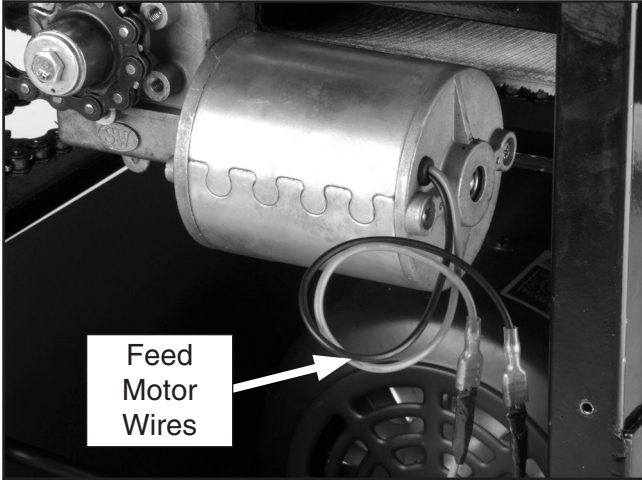

**Figure 51.** Worm wheel and worm gear.





# Electrical Components



**Feed Motor**



**Capacitor**

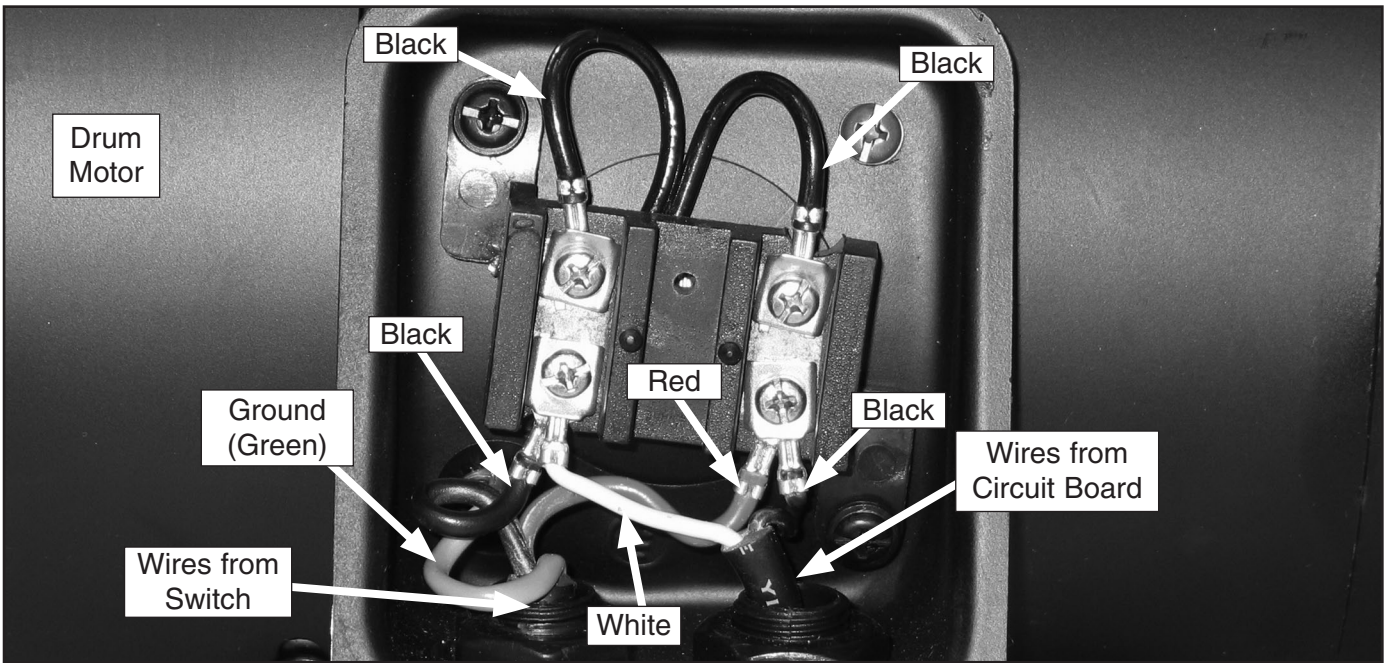

**Motor Wiring**

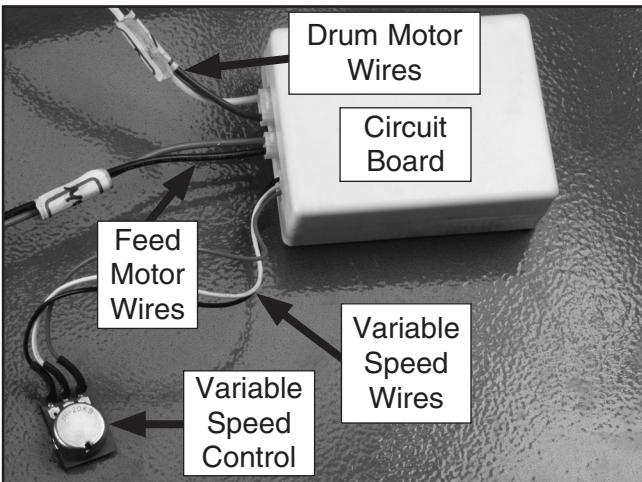

**Variable Speed Control, Circuit Board**

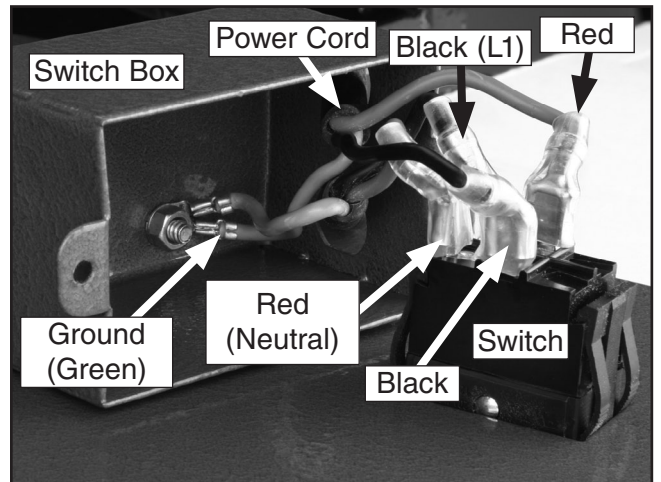

**Switch Box Wiring**



# Wiring Diagram

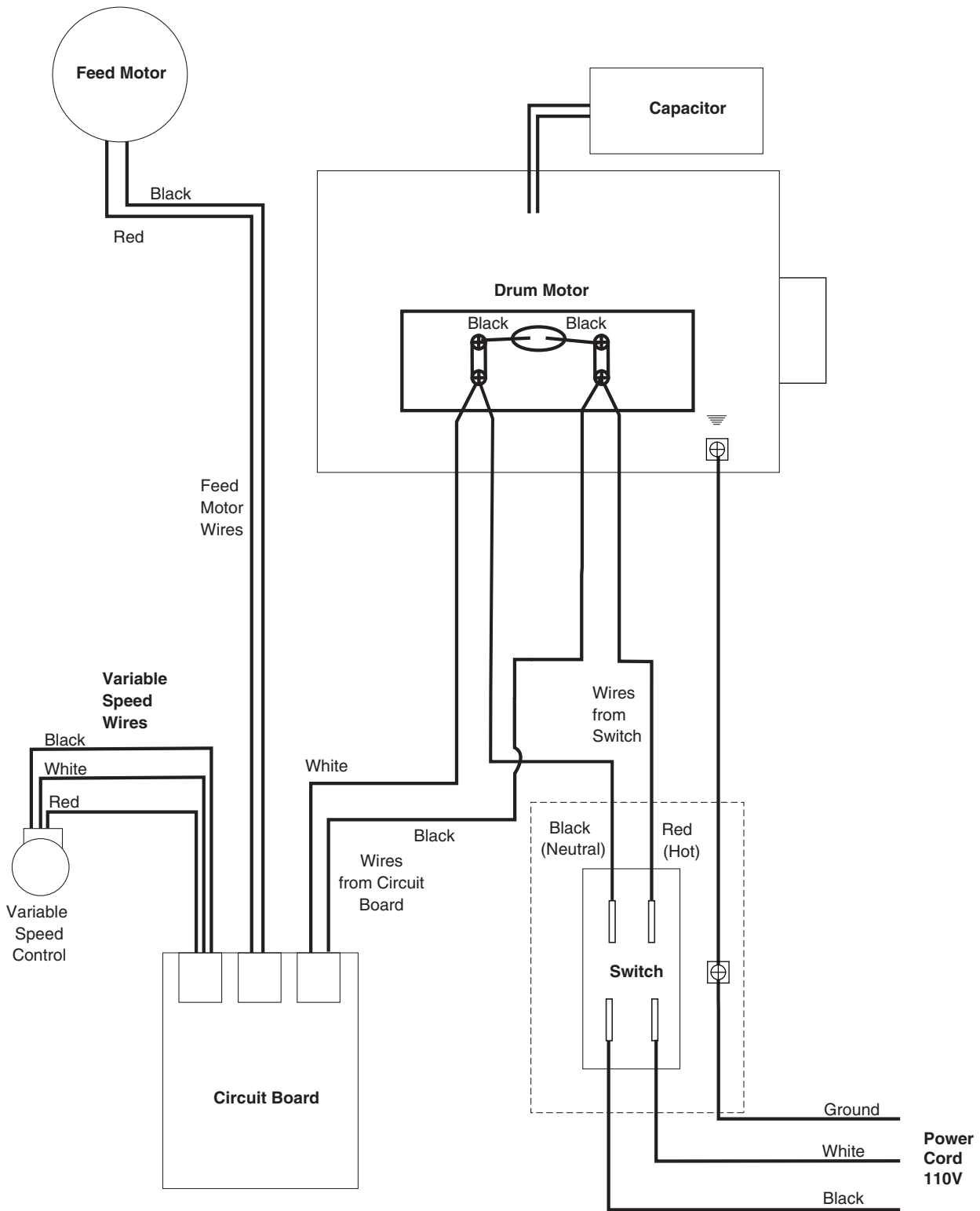

# Frame Parts Breakdown

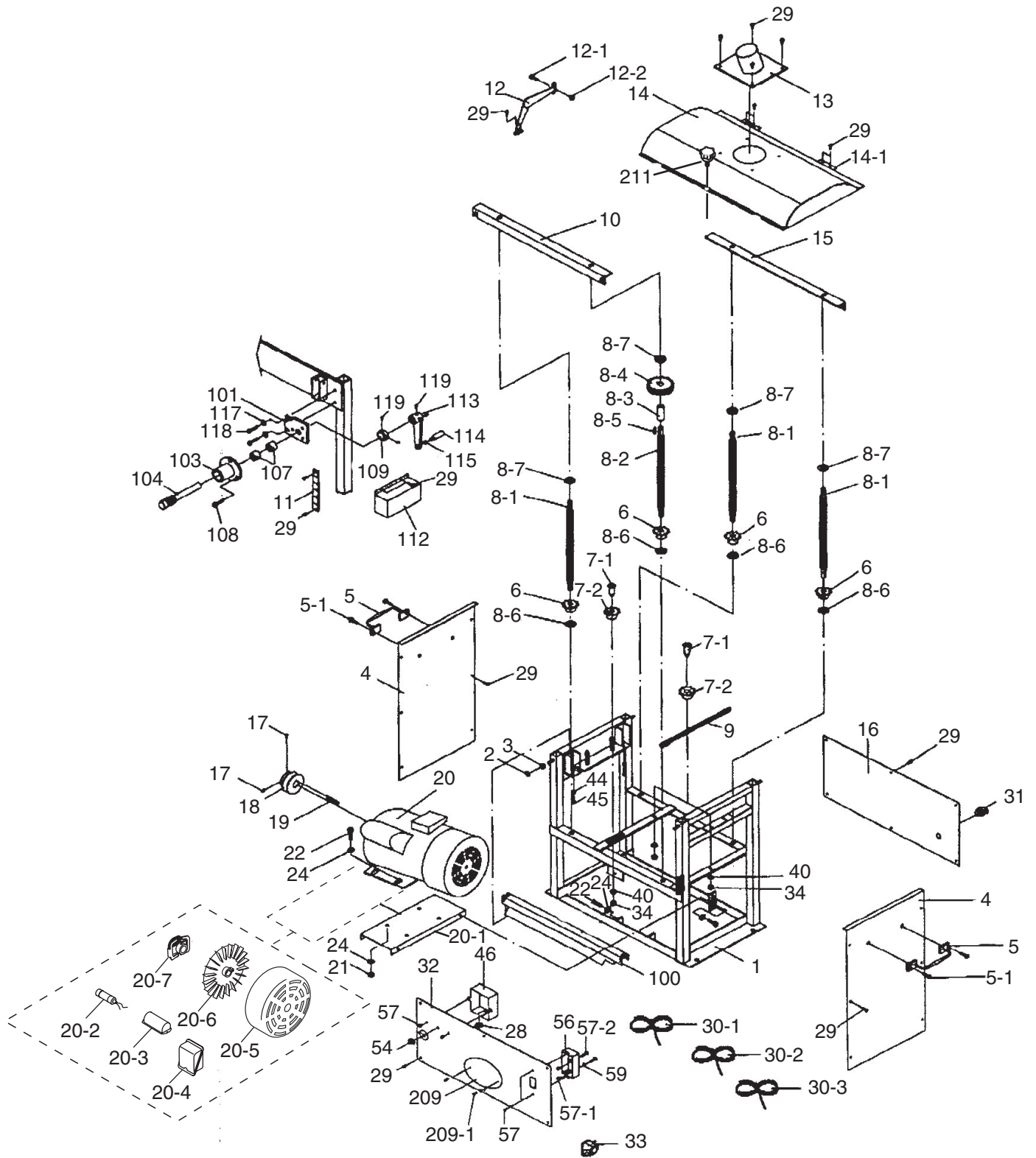

# Drum and Conveyor Parts Breakdown

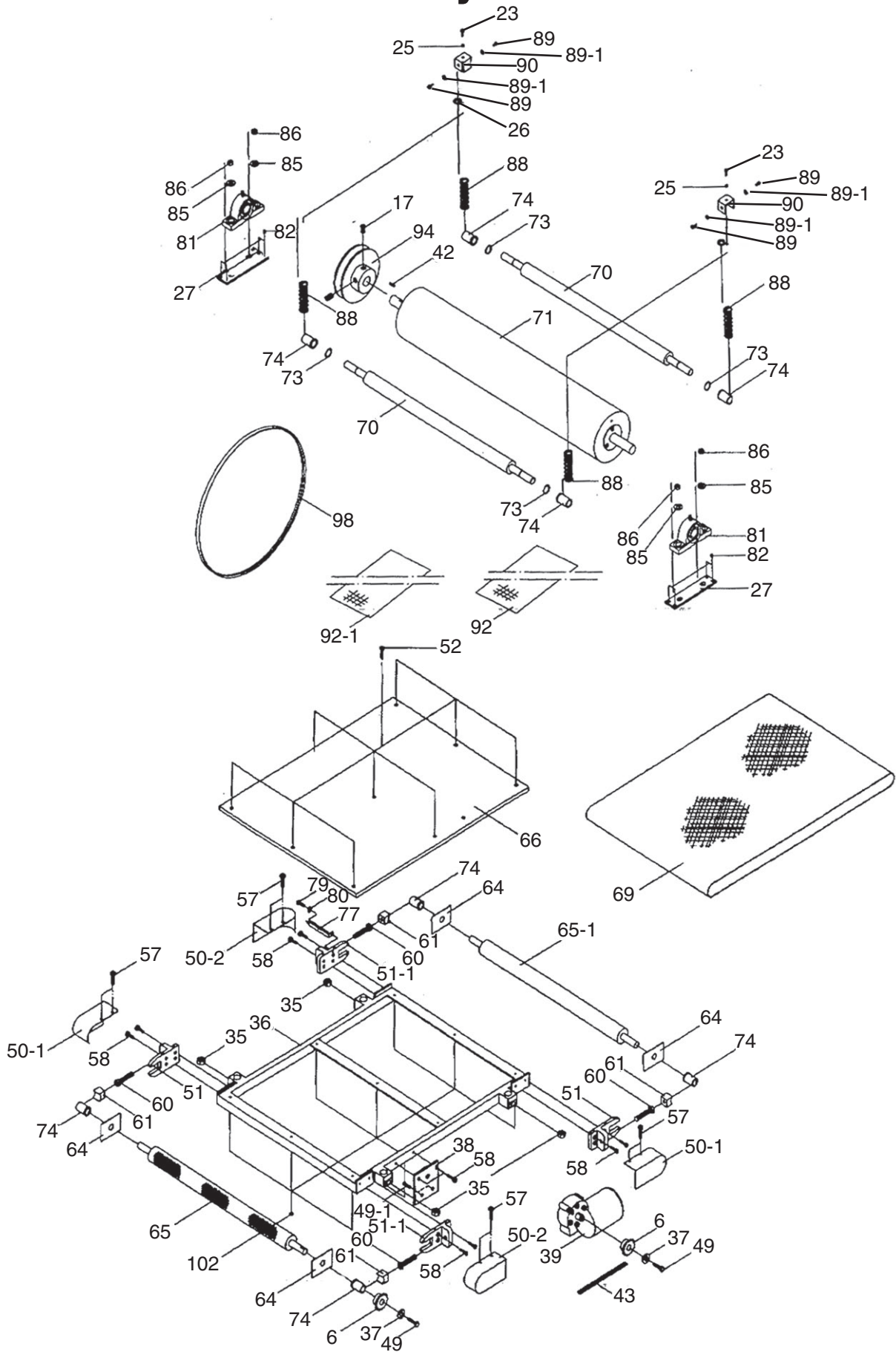

# Parts List

REF	PART #	DESCRIPTION
1	P0459001	FRAME
2	PN02	HEX NUT 5/16-18
3	PW07	FLAT WASHER 5/16
4	P0459004	SIDE PANEL
5	P0459005	HANDLE
5-1	PSB09	CAP SCREW 5/16-18 X 5/8
6	P0459006	SPROCKET
7-1	P0459007-1	SPROCKET SHAFT
7-2	P0459007-2	SPROCKET
8-1	P0459008-1	TABLE LIFT SCREW
8-2	P0459008-2	TABLE LIFT SCREW
8-3	P0459008-3	BUSHING
8-4	P0459008-4	WORM WHEEL
8-5	PK06M	KEY 5 X 5 X 10
8-6	P0459008-6	BRASS WASHER 1/2
8-7	PW01	FLAT WASHER 1/2
9	P0459009	ELEVATION CHAIN
10	P0459010	FRONT BRACE
11	P0459011	DEPTH SCALE
12	P0459012	RIGHT SUPPORT ARM
12-1	PS41	PHLP HD SCREW 6-32 X 1/4
12-2	PN12	HEX NUT 6-32
13	P0459013	DUST PORT
14	P0459014	TOP COVER
14-1	P0459014-1	HINGE
15	P0459015	REAR BRACE
16	P0459016	REAR PANEL
17	PSS03	SETSCREW 1/4-20 X 3/8
18	P0459018	MOTOR PULLEY
19	PK110	KEY 1/4 X 1/4 X 1
20	P0459020	1.5HP MOTOR 110V
20-1	P0459020-1	MOTOR BRACKET
20-2	P0459020-2	CAPACITOR 300MFD, 125VAC
20-3	P0459020-3	CAPACITOR COVER
20-4	P0459020-4	MOTOR WIRING COVER
20-5	P0459020-5	FAN COVER
20-6	P0459020-6	MOTOR FAN
20-7	P0459020-7	CENTRIFUGAL SWITCH
21	PN02	HEX NUT 5/16-18
22	PB507	HEX BOLT 5/16-18 X 3/4
23	PB02	HEX BOLT 1/4-20 X 5/8
24	PW07	FLAT WASHER 5/16
25	PN05	HEX NUT 1/4-20
26	P0459026	SPRING PLATE
27	P0459027	ADJUST PLATE
28	P0459028	GROMMET
29	PHTEK7	TAP SCREW #8 X 3/8
30-1	P0459030-1	POWER CORD
30-2	P0459030-2	MOTOR CORD
30-3	P0459030-3	VS POWER CORD
31	P0459031	STRAIN RELIEF
32	P0459032	FRONT PANEL
33	P0459033	SWITCH

REF	PART #	DESCRIPTION
34	PN02	HEX NUT 5/16-18
35	PN03	HEX NUT 3/4-16
36	P0459036	TABLE FRAME
37	PW06	FLAT WASHER 1/4
38	P0459038	CONVEYOR MOTOR PLATE
39	P0459039	CONVEYOR MOTOR
40	PW07	FLAT WASHER 5/16
42	PK34M	KEY 5 X 5 X 20
43	P0459043	CONVEYOR MOTOR CHAIN
44	PN05	HEX NUT 1/4-20
45	PB05	HEX BOLT 1/4-20 X 3/4
46	P0459046	PC BOARD CONSOLE UNIT
49	PFH04	FLAT HD SCREW 1/4-20 X 5/8
49-1	PB19	HEX BOLT 1/4-20 X 1/2
50-1	P0459050-1	LEFT ROLLER END GUARD COVER
50-2	P0459050-2	RIGHT ROLLER END GUARD COVER
51	P0459051	LEFT ROLLER BRACKET
51-1	P0459051-1	RIGHT ROLLER BRACKET
52	PFH12	FLT HD SCREW 1/4-20 X 1
54	P0459054	VARIABLE SPEED CONTROL KNOB
56	P0459056	SWITCH BOX
57	P0459057	FLANGE SCREW 10-24 X 1/2
57-1	PN07	HEX NUT 10-24
57-2	PS06	PHLP HD SCREW 10-24 X 3/8
58	PSB05	CAP SCREW 1/4-20 X 3/4
59	PTLW02M	EXT TOOTH WASHER 5MM
60	P0459060	SPECIAL BOLT
61	P0459061	BUSHING SUPPORT
64	P0459064	PLATE
65	P0459065	DRIVE ROLLER
65-1	P0459065-1	IDLER ROLLER
66	P0459066	TABLE
69	P0459069	CONVEYOR BELT
70	P0459070	PRESSURE ROLLER
71	P0459071	SANDING DRUM
73	P0459073	EXTERNAL RETAINING RING 19MM
74	P0459074	BUSHING
77	P0459077	SCALE POINTER
79	PS06	PHLP HD SCREW 10-24 X 3/8
80	PW03	FLAT WASHER #10
81	P0459081	PILLOW BLOCK BEARING
82	P0459082	SETSCREW 5/16-24 X 1/2
85	PW02	FLAT WASHER 3/8
86	PLN01	LOCK NUT 3/8-16
88	P0459088	COMPRESSION SPRING
89	PB51	HEX BOLT 1/4-20 X 3/8
89-1	PW06	FLAT WASHER 1/4
90	P0459090	BRACKET
92	P0459092	HOOK & LOOP SANDBELT
92-1	P0459092-1	HOOK & LOOP DRUM COVER
94	P0459094	DRUM PULLEY
98	PVA36	V-BELT A-36 4L360
99	PAW03M	HEX WRENCH 3MM



# Parts List

REF	PART #	DESCRIPTION
100	P0459100	DUST SCOOP
101	P0459101	WORM GEAR SHAFT BRACKET
102	PLN02	LOCK NUT 1/4-20
103	P0459103	SHAFT MOUNT
104	P0459104	WORM GEAR
107	P0459107	BUSHING
108	PB19	HEX BOLT 1/4-20 X 1/2
109	P0459109	COLLAR
112	P0459112	GEAR COVER

REF	PART #	DESCRIPTION
113	P0459113	CRANK HANDLE
114	P0459114	HANDLE
115	PN08	HEX NUT 3/8-16
117	PW07	FLAT WASHER 5/16
118	PB03	HEX BOLT 5/16-18 X 1
119	PSS11	SETSCREW 1/4-20 X 1/4
209	G9987	GRIZZLY NAMEPLATE-MINI
209-1	P0459209-1	TAP SCREW #5 X 3/8
211	P0459211	COVER LOCK KNOB



# Safety Label Placement and Parts List

## **!WARNING**

The safety labels on this machine warn and indicate how to protect the operator or bystander from machine hazards. The machine owner **MUST** maintain the original label location and readability. If a label is removed or becomes unreadable, **REPLACE** the label before using the machine. For new labels, contact Grizzly Industrial Inc. at (570) 546-9663 or [techsupport@grizzly.com](mailto:techsupport@grizzly.com).

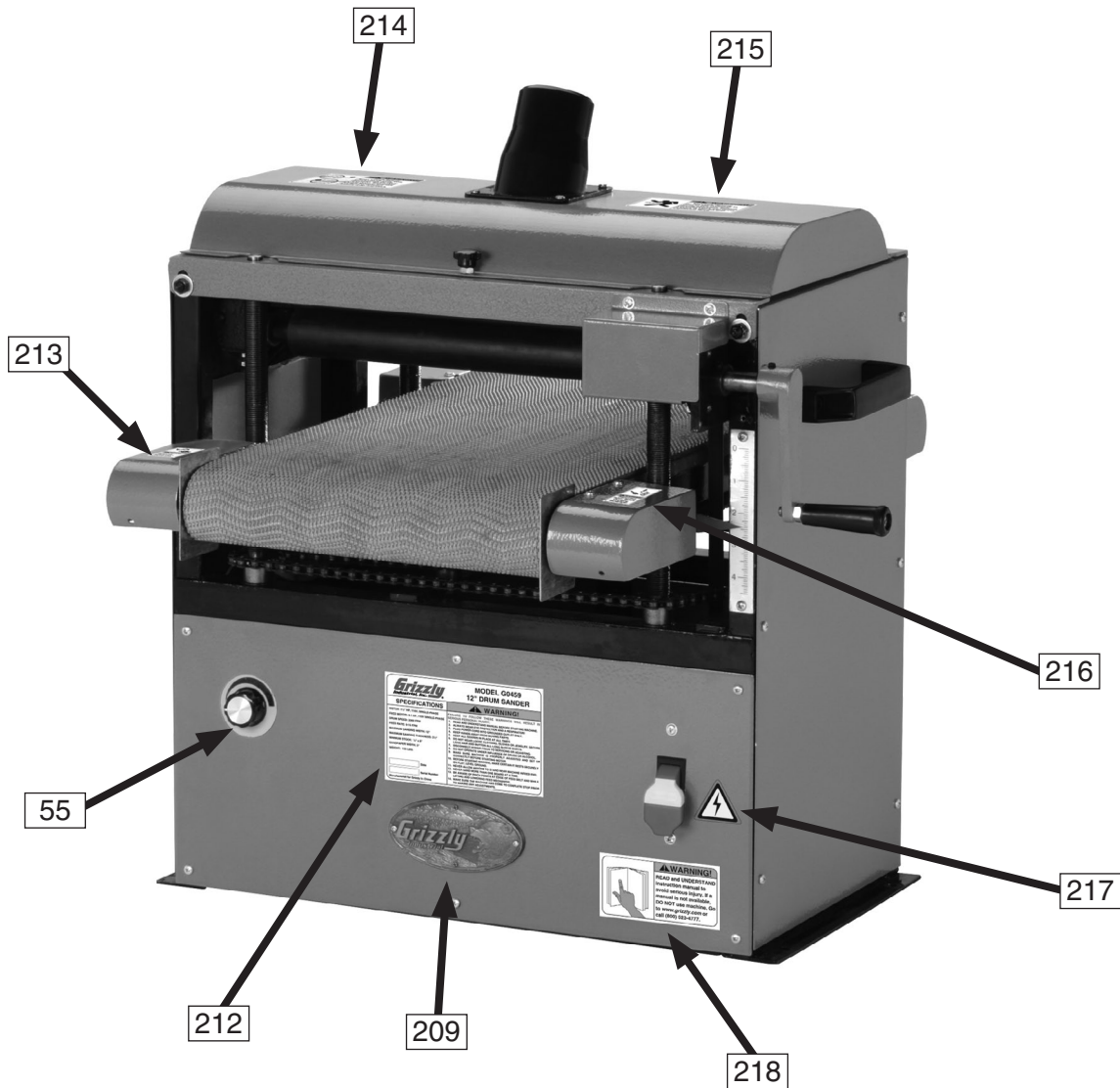

REF	PART #	DESCRIPTION
55	P0459055	SPEED INDICATOR LABEL
209	G9987	GRIZZLY NAMEPLATE-MINI
212	P0459212	MACHINE ID LABEL
213	P0459213	LABEL (DUST-EYE)
214	PLABEL-22	LABEL (HAND PINCH IN BELT)

REF	PART #	DESCRIPTION
215	P0459215	LABEL (KICKBACK HAZARD)
216	P0459216	LABEL (DISCONNECT POWER)
217	PLABEL-14	LABEL(ELECTRICITY)
218	PLABEL-12B	LABEL (READ MANUAL HORZ.)



# WARRANTY AND RETURNS

---

Grizzly Industrial, Inc. warrants every product it sells for a period of **1 year** to the original purchaser from the date of purchase. This warranty does not apply to defects due directly or indirectly to misuse, abuse, negligence, accidents, repairs or alterations or lack of maintenance. This is Grizzly's sole written warranty and any and all warranties that may be implied by law, including any merchantability or fitness, for any particular purpose, are hereby limited to the duration of this written warranty. We do not warrant or represent that the merchandise complies with the provisions of any law or acts unless the manufacturer so warrants. In no event shall Grizzly's liability under this warranty exceed the purchase price paid for the product and any legal actions brought against Grizzly shall be tried in the State of Washington, County of Whatcom.

We shall in no event be liable for death, injuries to persons or property or for incidental, contingent, special, or consequential damages arising from the use of our products.

To take advantage of this warranty, contact us by mail or phone and give us all the details. We will then issue you a "Return Number," which must be clearly posted on the outside as well as the inside of the carton. We will not accept any item back without this number. Proof of purchase must accompany the merchandise.

The manufacturers reserve the right to change specifications at any time because they constantly strive to achieve better quality equipment. We make every effort to ensure that our products meet high quality and durability standards and we hope you never need to use this warranty.

Please feel free to write or call us if you have any questions about the machine or the manual.

Thank you again for your business and continued support. We hope to serve you again soon.







# WARRANTY CARD

Name \_\_\_\_\_  
 Street \_\_\_\_\_  
 City \_\_\_\_\_ State \_\_\_\_\_ Zip \_\_\_\_\_  
 Phone # \_\_\_\_\_ Email \_\_\_\_\_ Invoice # \_\_\_\_\_  
 Model # \_\_\_\_\_ Order # \_\_\_\_\_ Serial # \_\_\_\_\_

The following information is given on a voluntary basis. It will be used for marketing purposes to help us develop better products and services. **Of course, all information is strictly confidential.**

1. How did you learn about us?

Advertisement       Friend       Catalog  
 Card Deck       Website       Other:

2. Which of the following magazines do you subscribe to?

<input type="checkbox"/> Cabinet Maker	<input type="checkbox"/> Popular Mechanics	<input type="checkbox"/> Today's Homeowner
<input type="checkbox"/> Family Handyman	<input type="checkbox"/> Popular Science	<input type="checkbox"/> Wood
<input type="checkbox"/> Hand Loader	<input type="checkbox"/> Popular Woodworking	<input type="checkbox"/> Wooden Boat
<input type="checkbox"/> Handy	<input type="checkbox"/> Practical Homeowner	<input type="checkbox"/> Woodshop News
<input type="checkbox"/> Home Shop Machinist	<input type="checkbox"/> Precision Shooter	<input type="checkbox"/> Woodsmith
<input type="checkbox"/> Journal of Light Cont.	<input type="checkbox"/> Projects in Metal	<input type="checkbox"/> Woodwork
<input type="checkbox"/> Live Steam	<input type="checkbox"/> RC Modeler	<input type="checkbox"/> Woodworker West
<input type="checkbox"/> Model Airplane News	<input type="checkbox"/> Rifle	<input type="checkbox"/> Woodworker's Journal
<input type="checkbox"/> Modeltec	<input type="checkbox"/> Shop Notes	<input type="checkbox"/> Other:
<input type="checkbox"/> Old House Journal	<input type="checkbox"/> Shotgun News	

3. What is your annual household income?

\$20,000-\$29,000       \$30,000-\$39,000       \$40,000-\$49,000  
 \$50,000-\$59,000       \$60,000-\$69,000       \$70,000+

4. What is your age group?

20-29       30-39       40-49  
 50-59       60-69       70+

5. How long have you been a woodworker/metalworker?

0-2 Years       2-8 Years       8-20 Years       20+ Years

6. How many of your machines or tools are Grizzly?

0-2       3-5       6-9       10+

7. Do you think your machine represents a good value?

Yes       No

8. Would you recommend Grizzly Industrial to a friend?

Yes       No

9. Would you allow us to use your name as a reference for Grizzly customers in your area?

Note: *We never use names more than 3 times.*       Yes       No

10. Comments: \_\_\_\_\_  
 \_\_\_\_\_  
 \_\_\_\_\_  
 \_\_\_\_\_

CUT ALONG DOTTED LINE

FOLD ALONG DOTTED LINE

\_\_\_\_\_  
\_\_\_\_\_  
\_\_\_\_\_



Place  
Stamp  
Here



**GRIZZLY INDUSTRIAL, INC.**  
**P.O. BOX 2069**  
**BELLINGHAM, WA 98227-2069**



FOLD ALONG DOTTED LINE

Send a Grizzly Catalog to a friend:

Name \_\_\_\_\_  
Street \_\_\_\_\_  
City \_\_\_\_\_ State \_\_\_\_\_ Zip \_\_\_\_\_

TAPE ALONG EDGES--PLEASE DO NOT STAPLE



# *grizzly.com*

**TOOL WEBSITE**

Buy Direct and Save with Grizzly® – Trusted, Proven and a Great Value!

*Visit Our Website Today And Discover Why  
Grizzly® Is The Industry Leader!*

- SECURE ORDERING
- ORDERS SHIPPED WITHIN 24 HOURS
- E-MAIL RESPONSE WITHIN ONE HOUR

-OR-

Call Today For A **FREE**  
Full Color Catalog

**1-800-523-4777**

