

Grizzly **Industrial, Inc.**®

MODEL G0492 12" X 36" COMBO LATHE/MILL OWNER'S MANUAL



COPYRIGHT © AUGUST, 2006 BY GRIZZLY INDUSTRIAL, INC.
**WARNING: NO PORTION OF THIS MANUAL MAY BE REPRODUCED IN ANY SHAPE
OR FORM WITHOUT THE WRITTEN APPROVAL OF GRIZZLY INDUSTRIAL, INC.**
#CR8520 PRINTED IN CHINA

WARNING!

This manual provides critical safety instructions on the proper setup, operation, maintenance and service of this machine/equipment.

Failure to read, understand and follow the instructions given in this manual may result in serious personal injury, including amputation, electrocution or death.

The owner of this machine/equipment is solely responsible for its safe use. This responsibility includes but is not limited to proper installation in a safe environment, personnel training and usage authorization, proper inspection and maintenance, manual availability and comprehension, application of safety devices, blade/cutter integrity, and the usage of personal protective equipment.

The manufacturer will not be held liable for injury or property damage from negligence, improper training, machine modifications or misuse.

WARNING!

Some dust created by power sanding, sawing, grinding, drilling, and other construction activities contains chemicals known to the State of California to cause cancer, birth defects or other reproductive harm. Some examples of these chemicals are:

- **Lead from lead-based paints.**
- **Crystalline silica from bricks, cement and other masonry products.**
- **Arsenic and chromium from chemically-treated lumber.**

Your risk from these exposures varies, depending on how often you do this type of work. To reduce your exposure to these chemicals: Work in a well ventilated area, and work with approved safety equipment, such as those dust masks that are specially designed to filter out microscopic particles.

Table of Contents

INTRODUCTION	3
Foreword	3
Contact Info.....	3
Machine Data Sheet.....	4
Identification	6
SECTION 1: SAFETY	7
Safety Instructions for Machinery.....	7
Additional Safety Instructions for Lathe/Mills	9
Glossary of Terms.....	10
SECTION 2: CIRCUIT REQUIREMENTS	11
220V Single-Phase	11
SECTION 3: SET UP	12
Set Up Safety.....	12
Unpacking and Lifting.....	12
Inventory.....	13
Site Considerations	14
Clean Up	14
SECTION 4: LATHE OPERATIONS	15
Operation Safety	15
The Power Supply.....	15
Test Run & Break-In	16
Mounting the Chuck and the Faceplate	17
Replacing the Jaws	18
Using the Four-Jaw Chuck.....	19
Using the Faceplate	20
Using the Tailstock.....	21
Drilling with the Tailstock	21
Cutting Shallow Tapers with Tailstock	22
Aligning Tailstock	22
Using the Centers	24
Using the Steady Rest	25
Using the Follow Rest	25
Using the Compound rest	26
Using the Tool Post.....	26
Using the Manual Feed Handwheels.....	27
Setting the Spindle RPM.....	27
Setting the Power Feed Rate.....	29
Setup for Threading	30
Change Gear Chart.....	31
SECTION 5: MILL OPERATIONS	32
Test Run & Break-In	32
Positioning the Headstock.....	33
Using the Mill Table	33
Installing Cutters	34
Removing Cutters	34
Setting the Spindle RPM	35
Using the Mill.....	35
SECTION 6: MAINTENANCE	36
Basic Maintenance	36
General Lubrication.....	36
General Cleaning	36
Belt Adjustment or Replacement	37

SECTION 7: SERVICE	38
Cross Slide Backlash Adjustment	38
Gib Adjustments	38
Electrical Component and Connection Index	39
220V Wiring Diagram	42
Troubleshooting.....	43
SECTION 8: ACCESSORIES	46
SECTION 9: PARTS	47
Electrical Box	47
0000 Series Parts List	47
Lathe Change Gear Housing Diagram.....	48
1000 Series Parts List	49
Leadscrew Gearbox Diagram	50
2700 Series Parts List	51
Thread Dial Diagram	52
3000 Series Parts List	53
Compound Rest and Tool Post Diagram	54
3500 Series Parts List	55
Bed Diagram	56
4000 Series Parts List	57
Steady Rest and Follow Rest Diagram	58
4500 Series Parts List	59
Tailstock Diagram	60
5700 Series Parts List	61
Apron Diagram	62
6000 Series Parts List	63
Headstock Diagram	64
7500 Series Parts List	65
Mill Column Diagram	66
8000 Series Parts List	67
Accessories and Labels Diagram	68
9000 Series Parts List	69
WARRANTY AND RETURNS	70



INTRODUCTION

Foreword

We are proud to offer the Model G0492 12" X 36" Combo Lathe/Mill. This machine is part of a growing Grizzly family of fine metalworking machinery. When used according to the guidelines set forth in this manual, you can expect years of trouble-free, enjoyable operation and proof of Grizzly's commitment to customer satisfaction.

We are pleased to provide this manual with the Model G0492. It was written to guide you through assembly, review safety considerations, and cover general operating procedures. It represents our effort to produce the best documentation possible.

The specifications, drawings, and photographs illustrated in this manual represent the Model G0492 as supplied when the manual was prepared. However, owing to Grizzly's policy of continuous improvement, changes may be made at any time with no obligation on the part of Grizzly. For your convenience, we always keep current Grizzly manuals available on our website at **www.grizzly.com**. Any updates to your machine will be reflected in these manuals as soon as they are complete. Visit our site often to check for the latest updates to this manual!

Contact Info

If you have any comments regarding this manual, please write to us at the address below:

Grizzly Industrial, Inc.
c/o Technical Documentation Manager
P.O. Box 2069
Bellingham, WA 98227-2069

We stand behind our machines. If you have any service questions or parts requests, please call or write us at the location listed below.

Grizzly Industrial, Inc.
1203 Lycoming Mall Circle
Muncy, PA 17756
Phone: (570) 546-9663
Fax: (800) 438-5901
E-Mail: techsupport@grizzly.com
Web Site: <http://www.grizzly.com>





MACHINE DATA SHEET

Customer Service #: (570) 546-9663 • To Order Call: (800) 523-4777 • Fax #: (800) 438-5901

MODEL G0492 12" X 36" COMBO LATHE/MILL

Product Dimensions:

Approximate Net Weight 1200 lbs.
Overall Dimensions 67-3/4" Wide x 26-3/4" Deep x 72" Tall
Footprint 16-1/2" Deep x 59-1/4" Wide

Shipping Dimensions:

Type Wood
Content Assembled Machine
Approximate Shipping Weight 1400 lbs.

Electrical:

Mill Power Switch Toggle On/Off with Safety Lock Tab
Lathe Power Switch Emergency Push-button Kill Switch w/Manual Reset
Switch Voltage 24VAC
Cord Length 4 ft.
Cord Gauge 14 gauge
Recommended Breaker Size 20A
Plug No

Motors:

Lathe Motor

Type TEFC Capacitor Start Induction
Horsepower 1-1/2 HP
Voltage 220V
Phase Single
Amps 10A
Speed 1725 RPM
Cycle 60 Hz
Power Transfer V-Belt Drive
Bearings Shielded and Lubricated

Mill Motor

Type TEFC Capacitor Start Induction
Horsepower 3/4 HP
Voltage 220V
Phase Single
Amps 7A
Speed 1725 RPM
Cycle 60 Hz
Power Transfer Gear Drive
Bearings Shielded and Lubricated



Lathe Information

Mill/Drill Spindle Taper R8, 7/16"-20 TPI
 Spindle Bore 1-7/16"
 Lathe Spindle Taper..... MT #5
 Tailstock Taper MT #3
 Tailstock Barrel Travel 3-5/16"
 Number of Lathe Speeds 12
 Lathe Speeds..... 75, 110, 140, 200, 240, 350, 420, 600, 720, 1050, 1250, 1900 RPM
 Cross Slide Travel..... 6-1/4"
 Thread Range (inches) 30 @ 5-48 TPI
 Thread Range (metric)..... 21 @ 0.45-6.0 mm
 Lathe Swing Over Bed 12-1/2"
 Distance Between Centers 36"

Mill Information

Mill/Drill Spindle Taper R8, 7/16"-20 TPI
 Mill Swing 14-1/2"
 Mill Spindle to Worktable Capacity 17-1/4"
 Number of Mill Speeds 4
 Mill Speed Range..... 240, 600, 1100, 2700 RPM
 Headstock Tilt 90° L & R

Other Specifications:

Country of Origin China
 Warranty..... 1 Year
 Serial Number Location Data Label on Headstock

Features:

Extended Lathe Bed 36"
 Drill Chuck..... 1-13mm JT-33
 4-Jaw Chuck 8"
 3-Jaw Chuck w/Int. & Ext. Jaws, 6"

Faceplate: 8"
 Tool Holder 4-Way Turret Tool Post
 Change Gears Steel
 Dead Centers MT5 & MT3



Identification

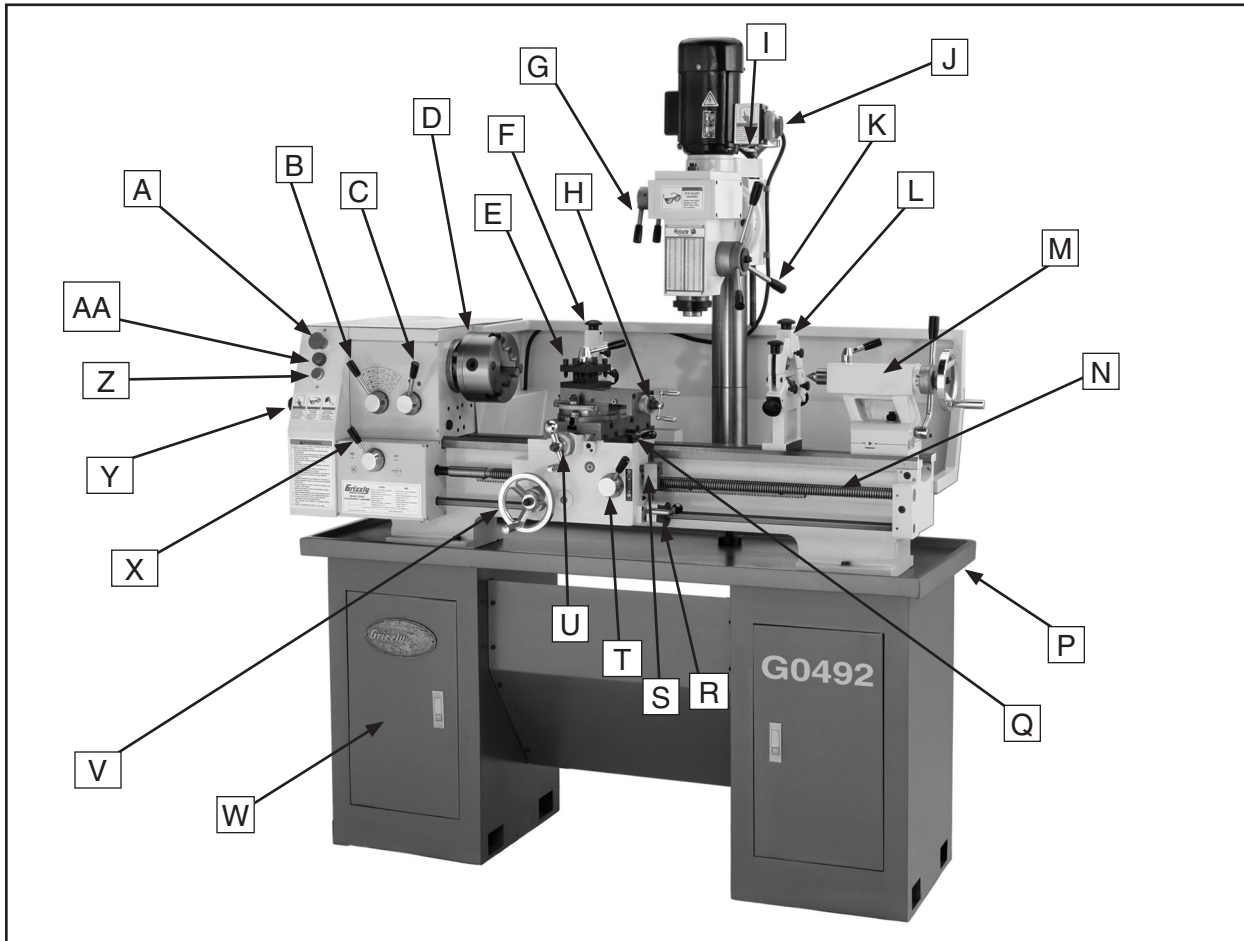

G0492 12" X 36" Combo Lathe/Mill.

- | | |
|--|--|
| A. Lathe Emergency Stop Button | P. Chip Tray and Drip Pan |
| B. Spindle Speed Lever | Q. Longitudinal and Cross slide Lever |
| C. Spindle Range Lever | R. Spindle ON/OFF Rotation Lever |
| D. 3-Jaw Chuck | S. Thread Dial |
| E. Four-Way Tool Post | T. Half Nut Lever |
| F. Follow Rest | U. Cross Slide Handle |
| G. Milling Speed Levers | V. Manual Feed Hand Wheel |
| H. Compound Rest | W. Storage Cabinet |
| I. Elevation Handwheel | X. Lead Screw Direction Lever |
| J. Mill Power/Emergency Stop Button | Y. Side Cover |
| K. Milling Rack Handles | Z. Jog Button |
| L. Steady Rest | AA. Power Lamp |
| M. Tailstock | |
| N. Lead Screw | |



SECTION 1: SAFETY

WARNING

For Your Own Safety, Read Instruction Manual Before Operating this Machine

The purpose of safety symbols is to attract your attention to possible hazardous conditions. This manual uses a series of symbols and signal words which are intended to convey the level of importance of the safety messages. The progression of symbols is described below. Remember that safety messages by themselves do not eliminate danger and are not a substitute for proper accident prevention measures.



Indicates an imminently hazardous situation which, if not avoided, **WILL** result in death or serious injury.



Indicates a potentially hazardous situation which, if not avoided, **COULD** result in death or serious injury.



Indicates a potentially hazardous situation which, if not avoided, **MAY** result in minor or moderate injury. It may also be used to alert against unsafe practices.

NOTICE

This symbol is used to alert the user to useful information about proper operation of the machine.

WARNING

Safety Instructions for Machinery

- 1. READ THROUGH THE ENTIRE MANUAL BEFORE STARTING MACHINERY.** Machinery presents serious injury hazards to untrained users.
- 2. ALWAYS USE ANSI APPROVED SAFETY GLASSES WHEN OPERATING MACHINERY.** Everyday eyeglasses only have impact resistant lenses—they are NOT safety glasses.
- 3. ALWAYS WEAR A NIOSH APPROVED RESPIRATOR WHEN OPERATING MACHINERY THAT PRODUCES DUST.** Wood dust is a carcinogen and can cause cancer and severe respiratory illnesses.
- 4. ALWAYS USE HEARING PROTECTION WHEN OPERATING MACHINERY.** Machinery noise can cause permanent hearing damage.
- 5. WEAR PROPER APPAREL. DO NOT** wear loose clothing, gloves, neckties, rings, or jewelry which may get caught in moving parts. Wear protective hair covering to contain long hair and wear non-slip footwear.
- 6. NEVER OPERATE MACHINERY WHEN TIRED, OR UNDER THE INFLUENCE OF DRUGS OR ALCOHOL.** Be mentally alert at all times when running machinery.



WARNING

Safety Instructions for Machinery

7. **ONLY ALLOW TRAINED AND PROPERLY SUPERVISED PERSONNEL TO OPERATE MACHINERY.** Make sure operation instructions are safe and clearly understood.
8. **KEEP CHILDREN AND VISITORS AWAY.** Keep all children and visitors a safe distance from the work area.
9. **MAKE WORKSHOP CHILD PROOF.** Use padlocks, master switches, and remove start switch keys.
10. **NEVER LEAVE WHEN MACHINE IS RUNNING.** Turn power **OFF** and allow all moving parts to come to a complete stop before leaving machine unattended.
11. **DO NOT USE IN DANGEROUS ENVIRONMENTS.** DO NOT use machinery in damp, wet locations, or where any flammable or noxious fumes may exist.
12. **KEEP WORK AREA CLEAN AND WELL LIT.** Clutter and dark shadows may cause accidents.
13. **USE A GROUNDED EXTENSION CORD RATED FOR THE MACHINE AMPERAGE.** Undersized cords overheat and lose power. Replace extension cords if they become damaged. DO NOT use extension cords for 220V machinery.
14. **ALWAYS DISCONNECT FROM POWER SOURCE BEFORE SERVICING MACHINERY.** Make sure switch is in OFF position before reconnecting.
15. **MAINTAIN MACHINERY WITH CARE.** Keep blades sharp and clean for best and safest performance. Follow instructions for lubricating and changing accessories.
16. **MAKE SURE GUARDS ARE IN PLACE AND WORK CORRECTLY BEFORE USING MACHINERY.**
17. **REMOVE ADJUSTING KEYS AND WRENCHES.** Make a habit of checking for keys and adjusting wrenches before turning machinery **ON**.
18. **CHECK FOR DAMAGED PARTS BEFORE USING MACHINERY.** Check for binding and alignment of parts, broken parts, part mounting, loose bolts, and any other conditions that may affect machine operation. Repair or replace damaged parts.
19. **USE RECOMMENDED ACCESSORIES.** Refer to the instruction manual for recommended accessories. The use of improper accessories may cause risk of injury.
20. **DO NOT FORCE MACHINERY.** Work at the speed for which the machine or accessory was designed.
21. **SECURE WORKPIECE.** Use clamps or a vise to hold the workpiece when practical. A secured workpiece protects your hands and frees both hands to operate the machine.
22. **DO NOT OVERREACH.** Keep proper footing and balance at all times.
23. **MANY MACHINES WILL EJECT THE WORKPIECE TOWARD THE OPERATOR.** Know and avoid conditions that cause the workpiece to "kickback."
24. **ALWAYS LOCK MOBILE BASES (IF USED) BEFORE OPERATING MACHINERY.**
25. **BE AWARE THAT CERTAIN DUST MAY BE HAZARDOUS** to the respiratory systems of people and animals, especially fine dust. Make sure you know the hazards associated with the type of dust you will be exposed to and always wear a respirator approved for that type of dust.



WARNING

Additional Safety Instructions for Lathe/Mills

- 1. UNDERSTANDING THE MACHINE:** Read and understand this manual before operating machine.
- 2. CLEANING MACHINE:** To avoid entanglement and lacerations, do not clear chips by hand. Use a brush, and never clear chips while the lathe is turning.
- 3. USING CORRECT TOOLING:** Always select the right cutter for the job, and make sure cutters are sharp. The right tool decreases strain on the lathe components and avoids unsafe cutting.
- 4. ELIMINATING A PROJECTILE HAZARD:** Always remove the chuck key, and never walk away from the lathe with the chuck key installed.
- 5. SECURING A WORKPIECE:** Make sure workpiece is properly held in chuck before starting lathe. A workpiece thrown from the chuck will cause severe injury.
- 6. AVOIDING OVERLOADS:** Always use the appropriate feed and speed rates.
- 7. MAINTAINING A SAFE WORKPLACE:** Never leave lathe unattended while it is running.
- 8. PREVENTING AN APRON-CHUCK CRASH:** Always release automatic feeds after completing a job.
- 9. AVOIDING STARTUP INJURIES:** Make sure workpiece, cutting tool, and tool post have adequate clearance before starting lathe. Check chuck clearance and saddle clearance before starting the lathe. Make sure spindle RPM is set correctly for part diameter before starting the lathe. Large parts can be ejected from the chuck if the chuck speed is set too high.
- 10. CHUCK SAFETY:** Chucks are surprisingly heavy and awkward to hold, so protect your hands and the lathe ways. Always use a chuck cradle or piece of plywood over the lathe ways.
- 11. WORKPIECE SUPPORT:** Support a long workpiece if it extends from the headstock so it will not wobble violently when the lathe is turned on. If workpiece extends more than 2.5 times its diameter from the chuck, support it by a center or steady rest or it may deflect and fall out of the chuck during cutting. chuck speed is set too high.
- 12. AVOIDING ENTANGLEMENT INJURIES:** Never attempt to slow or stop the lathe chuck or mill spindle by hand; and tie back long hair, ponytails, loose clothing, and sleeves so they do not dangle.

WARNING

Like all machinery there is potential danger when operating this machine. Accidents are frequently caused by lack of familiarity or failure to pay attention. Use this machine with respect and caution to lessen the possibility of operator injury. If normal safety precautions are overlooked or ignored, serious personal injury may occur.

CAUTION

No list of safety guidelines can be complete. Every shop environment is different. Always consider safety first, as it applies to your individual working conditions. Use this and other machinery with caution and respect. Failure to do so could result in serious personal injury, damage to equipment, or poor work results.



Glossary of Terms

The following is a list of common definitions, terms and phrases used throughout this manual as they relate to this lathe/mill and metalworking in general. Become familiar with these terms for assembling, adjusting or operating this machine. Your safety is **VERY** important to us at Grizzly!

Arbor: A machine shaft that supports a cutting tool.

Backlash: Wear in a screw or gear mechanism that may result in slippage, vibration, and loss of tolerance.

Collet: A conical shaped split-sleeve bushing which holds round or rectangular tool and/or workpieces by their outside diameter.

Cross Slide: A fixture attached to the lathe carriage that holds the compound rest and can be moved in and out.

Cutting Speed: The distance a point on a cutter moves in one minute, expressed in meters or feet per minute.

Dial Indicator: An instrument used in setup and inspection work that shows on a dial the amount of error in size or alignment of a part.

Dividing Head: A milling machine accessory used to divide a circular object into a number of equal parts.

Down Milling or Climb Milling: Feeding the workpiece in the same direction as the cutter rotation.

End Mill: A cutter with cutting surfaces on both its circumference and end.

Facing: In lathe work, cutting across the end of a workpiece, usually to machine a flat surface.

Feed: The movement of a cutting tool into a workpiece.

Fixture: A device that securely holds the workpiece in place during cutting operation as opposed to a **Jig** which is used to hold and guide a workpiece through an operation.

Gib: A tapered wedge located along a sliding member to take up wear or to ensure a proper fit.

Headstock: The major lathe component that houses the spindle and motor drive system to turn the workpiece.

Lathe Center: A lathe accessory with a 60° point which is inserted into the headstock or tailstock of the lathe and is used to support the workpiece.

Leadscrew: Lathe—The long screw that is driven by the end gears and supplies power to the carriage. Mill—The screws that move the table in longitudinal, transverse, or vertical directions.

Spindle: The revolving shaft that holds and drives the workpiece or cutting tool.

Tailstock: A moveable fixture opposite of the headstock on a lathe that has a spindle used to support one end of a workpiece and for holding tools.

Tool Post: The part of the compound rest that holds the tool holder.

Turret: Lathe—A machine fixture that holds multiple tools and can be revolved and indexed to position. Mill—The part of a mill which rotates on the column and can be set to a specific degree.

Ways: The precision machined and flat tracks on a lathe or mill on which the carriage, tailstock, and the mill table and knee slide.



SECTION 2: CIRCUIT REQUIREMENTS

220V Single-Phase

⚠️ WARNING

Serious personal injury could occur if you connect the machine to the power source before you have completed the set up process. DO NOT connect the machine to the power source until instructed to do so.

Amperage Draw

Combined, both of the G0492 Lathe/Mill motors draw the following amps under maximum load:

Both Motors Operating 17 Amps

Circuit Requirements

We recommend connecting your machine to a dedicated and grounded circuit that is rated for the amperage given below. Never replace a circuit breaker on an existing circuit with one of higher amperage without consulting a qualified electrician to ensure compliance with wiring codes. **If you are unsure about the wiring codes in your area or you plan to connect your machine to a shared circuit, consult a qualified electrician.**

220V Circuit..... 20 Amps

Plug/Receptacle Type

Recommended Plug/Receptacle..... NEMA 6-20

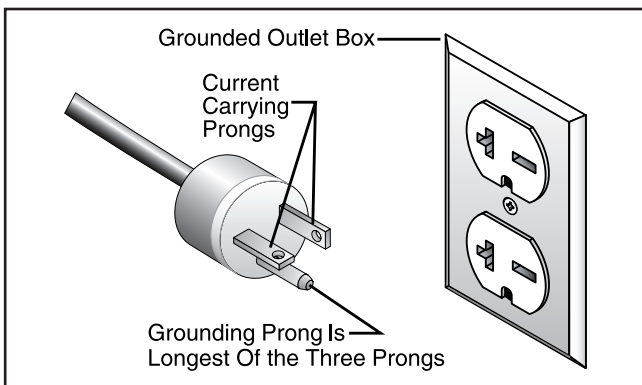
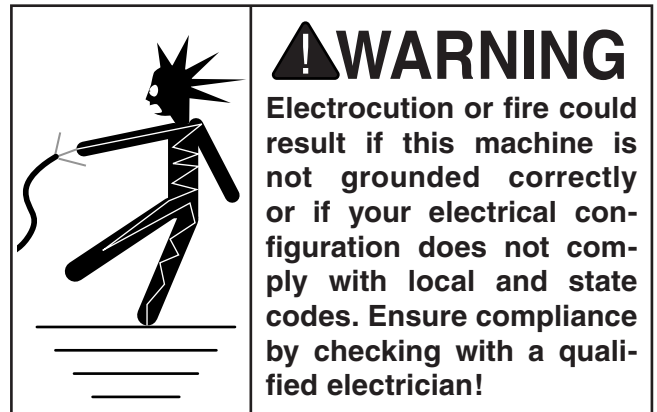

Figure 1. NEMA 6-20 plug and receptacle.

Grounding

In the event of an electrical short, grounding reduces the risk of electric shock. The grounding wire in the power cord must be properly connected to the grounding prong on the plug; likewise, the outlet must be properly installed and grounded. All electrical connections must be made in accordance with local codes and ordinances.



Extension Cords

We do not recommend the use of extension cords. Instead, arrange the placement of your equipment and the installed wiring to eliminate the need for extension cords.

If you find it absolutely necessary to use an extension cord at 220V with your machine:

- Use at least a 12 gauge cord that does not exceed 50 feet in length!
- The extension cord must also contain a ground wire and plug pin.
- A qualified electrician **MUST** size cords over 50 feet long to prevent motor damage.



SECTION 3: SET UP

Set Up Safety

WARNING

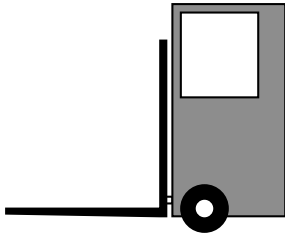

The Model G0492 weighs approximately 1200 lbs. You will need power lifting equipment and assistance to remove this machine from the pallet and position it. Inspect all lifting equipment and make sure that all is in perfect working order and is rated for the load before attempting to lift and move this lathe/mill. Ignoring this warning may lead to serious personal injury or death.

Unpacking and Lifting

The Model G0492 was carefully packed when it left our warehouse. If you discover the machine is damaged after you have signed for delivery, *please immediately call Customer Service at (570) 546-9663 for advice.*

Save the containers and all packing materials for possible inspection by the carrier or its agent. *Otherwise, filing a freight claim can be difficult.*

To unpack and move the lathe/mill:

1. Read **Pages 11, 12, & 14** to prepare the lathe/mill location, and install or prepare holes for any floor mounting fasteners.

2. Gather the following items:
 - Fork Lift or 2-ton hoist, and driver or operator.
 - 1 Ton lifting straps and hooks
3. Unbolt the crate sides and remove the top and sides.
4. Insert two lifting straps under the bedways and behind the feed rod and the lead screw as shown in **Figure 2** and support the lathe with the lifting straps and lifting device.
5. Move the apron between the headstock and the mill column as shown in **Figure 2** to balance the load.

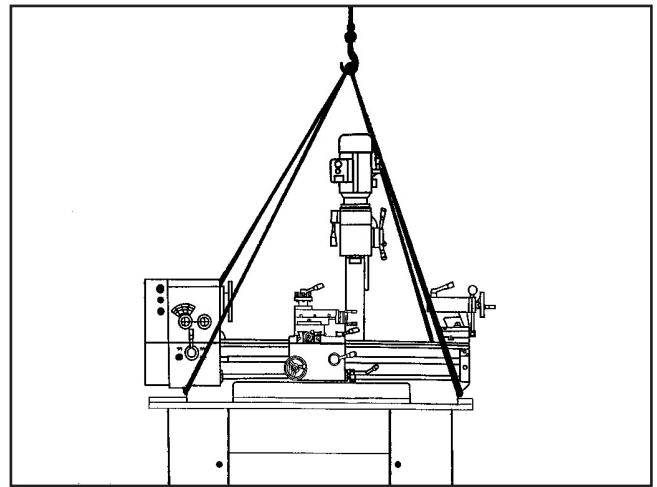

Figure 2. Lifting strap locations.

6. Unbolt the lathe/mill from the pallet.
7. Slowly raise the lathe/mill off of the pallet and carefully move the lathe/mill to your prepared location.
8. With the lathe/mill securely resting on the floor, shim between the floor and cabinet base as required to make the ways level at all four corner locations as indicated with a machinist's level.
9. Secure the lathe/mill to the floor, but **DO NOT** overtighten the fasteners.
10. Recheck the ways to make sure the ways are still level, and re-shim as required.



Inventory

After all the parts have been removed from the two boxes, you should have the following items:

Installed Accessories (Figure 3)..... Qty.

- A. 6" Three-Jaw Chuck..... 1
- B. 4-Way Tool Post and Compound Rest 1
- C. Follow Rest..... 1
- D. Steady Rest..... 1

Packaged Accessories (Figure 4)

- E. 8" Four-Jaw Universal Chuck..... 1
- F. 8" Faceplate 1
- G. Four-Jaw Chuck Key 1
- H. Drill Chuck (1-13mm, JT-33) 1
- I. Wrench Set (8/10, 10/12, 14/17, and 17/19 mm) 1 EA
- J. Hex Wrench Set (4, 5, 6, 8 mm) 1 EA
- K. Three-Jaw Chuck Key 1
- L. Oil Can 1
- M. Dead Center MT#5..... 1
- N. #2 Standard Screwdriver..... 1
- O. Wedge 1
- P. Tool Post T-Handle Wrench..... 1
- Q. Dead Center MT#3 w/Arbor 1
- R. Three-Jaw Chuck Internal Jaws..... 3
- S. Arbor JT-33 to MT#3 1
- T. Spot Paint..... 1
- U. Drill Chuck Key..... 1
- V. Change Gear Set 1
 - Gear (24-fine Tooth), (Installed) 1
 - Gear Set (28 & 35-Coarse Tooth) 1
 - Change Gear (24-tooth, 1 Installed)..... 2
 - Change Gear (25-tooth, 1 Installed)..... 2
 - Change Gear (27-tooth) 1
 - Change Gear (28-tooth) 1
 - Change Gear (30-tooth) 1
 - Change Gear (32-tooth) 2
 - Change Gear (34-tooth) 1
 - Change Gear (35-tooth) 1
 - Change Gear (36-tooth) 1
 - Change Gear (40-tooth) 1
 - Change Gear (42-tooth) 1
 - Change Gear (44-tooth) 1
 - Change Gear (46-tooth) 1
 - Change Gear (48-tooth, Installed) 1
 - Change Gear (50-tooth, Installed) 1
 - Change Gear (52-tooth) 1
 - Change Gear (60-tooth, Installed) 1

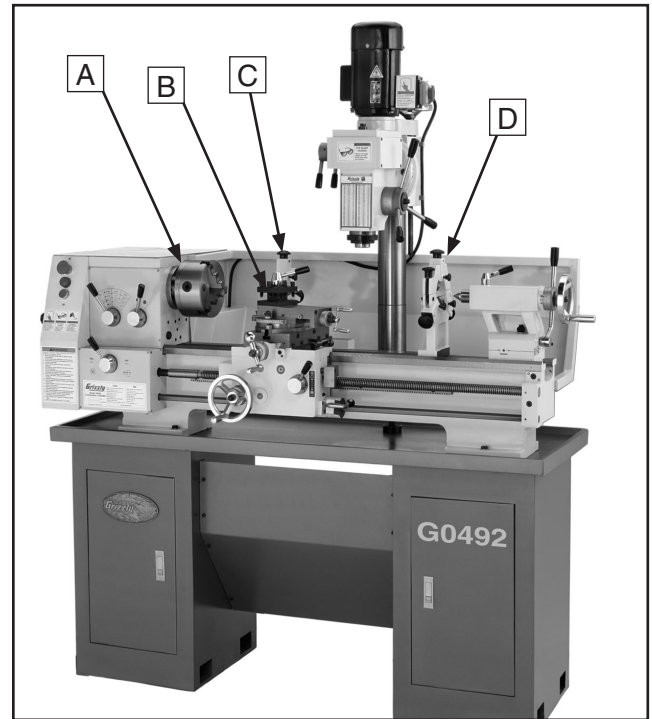

Figure 3. Installed accessories.

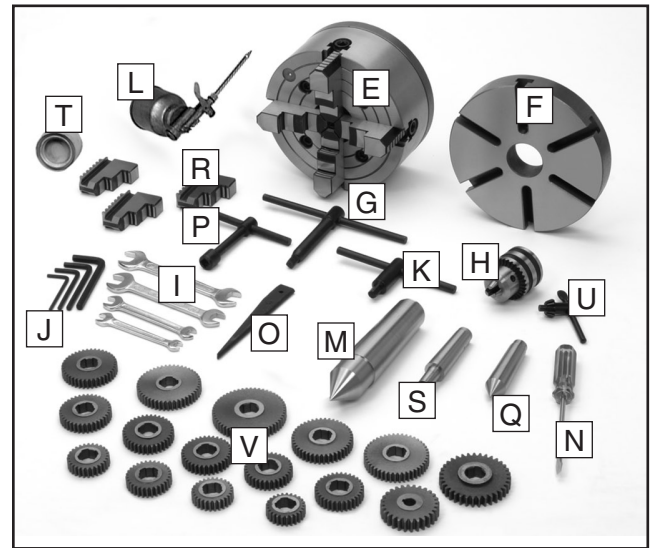

Figure 4. Packaged accessories.

In the event that any nonproprietary parts are missing (e.g. a nut or a washer), we would be glad to replace them, or for the sake of expediency, replacements can be obtained at your local hardware store.

NOTICE

Some hardware/fasteners on the inventory list may arrive pre-installed on the machine. Check these locations before assuming that any items from the inventory list are missing.



Site Considerations

Floor Load

Your lathe/mill is a heavy load (1200 lbs.) distributed in a small footprint. Place this machine on concrete floors only. The floor **MUST** be level, or the lathe/mill frame and ways may distort over time.

Placement Location

Consider existing and anticipated needs, service panel access, length of rods to be loaded into the lathe/mill, and space for auxiliary stands, work tables or other machinery when establishing a location for your lathe/mill (see **Figure 5** for minimum wall clearances).

	<p>⚠ CAUTION</p> <p>Unsupervised children and visitors inside your shop could cause serious personal injury to themselves. Lock all entrances to the shop when you are away and DO NOT allow unsupervised children or visitors in your shop at any time!</p>
--	--

Clean Up

The ways and other unpainted parts of your lathe/mill are coated with a waxy grease that protects them from corrosion during shipment. Clean this grease off with a solvent cleaner or citrus-based degreaser. **DO NOT** use chlorine-based solvents such as brake parts cleaner, lacquer thinner, or acetone—if you happen to splash some onto a painted surface, you will ruin the finish.

	<p>⚠ WARNING</p> <p>Gasoline and petroleum products ignite easily. DO NOT use gasoline or petroleum products to clean the machinery.</p>
--	--

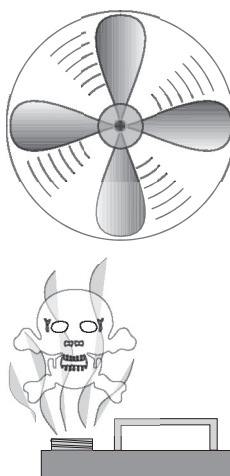
	<p>⚠ CAUTION</p> <p>Many of the solvents commonly used to clean machinery can be toxic when inhaled or ingested. Lack of ventilation while using these solvents could cause serious personal health risks or fire. Take precautions from this hazard by only using cleaning solvents in a well ventilated area.</p>
---	--

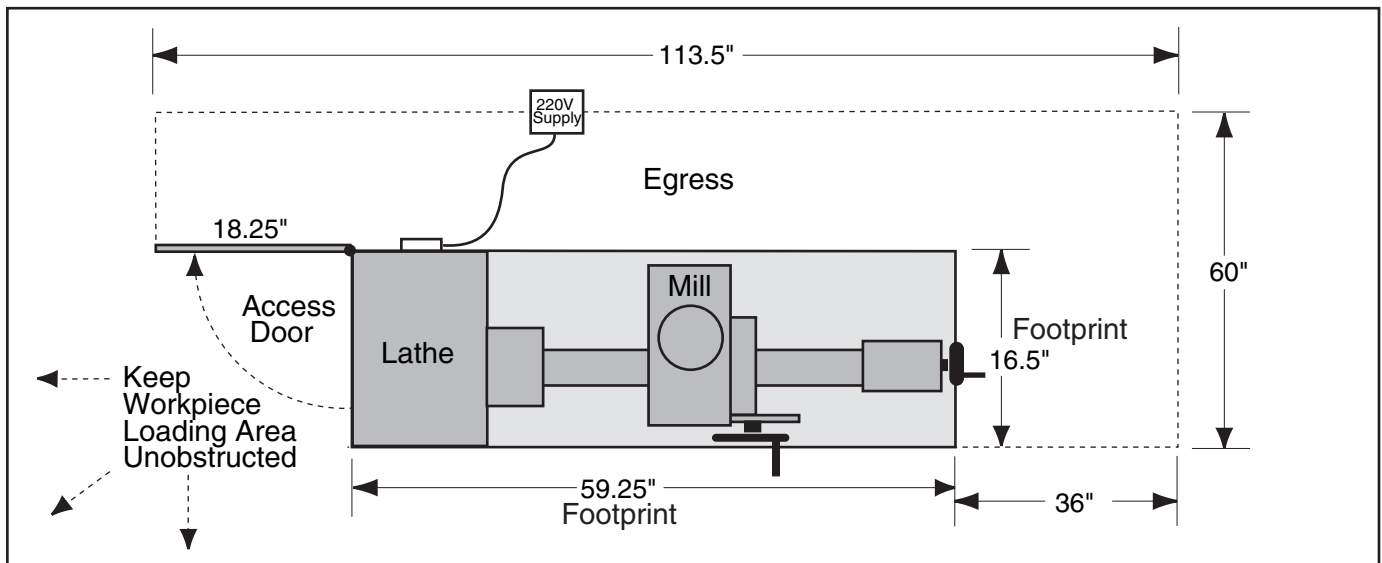

Figure 5. Minimum wall clearances.



SECTION 4: LATHE OPERATIONS

Operation Safety

!WARNING

Damage to your eyes, lungs, and ears could result from using this machine without proper protective gear. Always wear safety glasses, a respirator, and hearing protection when operating this machine.

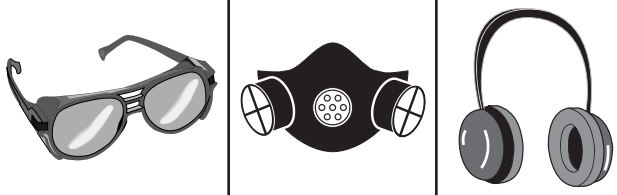

!WARNING

Loose hair and clothing could get caught in machinery and cause serious personal injury. Keep loose clothing and long hair away from moving machinery.

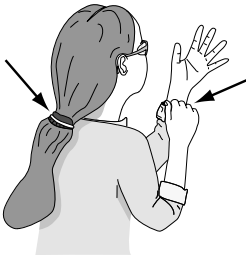

NOTICE

If you have never used this type of machine or equipment before, WE STRONGLY RECOMMEND that you read books, trade magazines, or get formal training before beginning any projects. Regardless of the content in this section, Grizzly Industrial will not be held liable for accidents caused by lack of training.

NOTICE

Complete the Test Run & Break-In procedure on Page 16 before using this lathe/mill for any cutting or threading operations; otherwise, gear box damage will occur.

The Power Supply

When illuminated, the power lamp (Figure 6) indicates that power is being supplied to the lathe/mill. Pressing the red emergency stop button will cut power for machine operations. Twisting the emergency stop button clockwise and letting it pop out will restore power for machine operations and reset the emergency stop button.

Note: The Spindle Rotation ON/OFF Lever (Figure 8) on the apron starts the spindle motor in a particular direction.

!WARNING

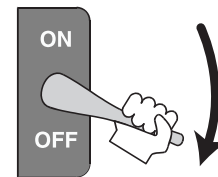

TURN OFF and LOCK your master power switch so no power is available to the lathe/mill, and make sure the spindle is stopped before proceeding with any adjustments or maintenance. Failure to comply may result in serious personal injury or death.

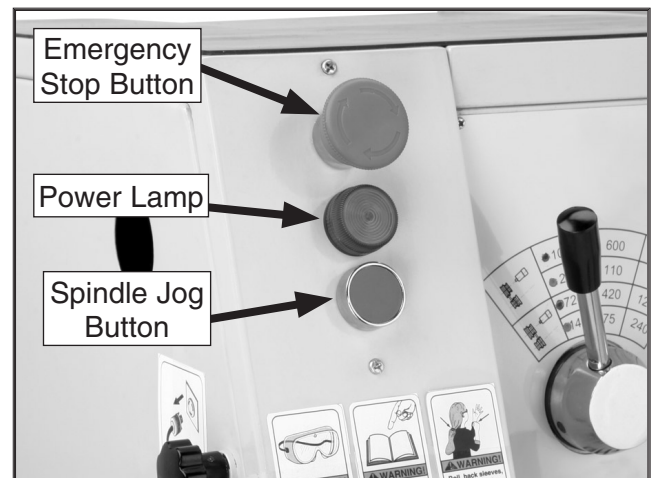

Figure 6. Power lamp and emergency stop location.



Test Run & Break-In

NOTICE

Make sure all power feed levers and dials are disengaged before starting the lathe/mill! Thoroughly familiarize yourself with all the controls and their functions before using any power feed! NEVER SHIFT LATHE/MILL GEARS WHEN MACHINE IS OPERATING.

The purpose of the test run is to make sure the lathe/mill and safety features operate correctly before proceeding with additional setup.

To begin the test run & break-in procedure:

1. Make sure the lathe/mill is lubricated and the headstock oil level is full. Refer to **Page 36** if required.
2. Make sure the chuck is bolted to the spindle.
3. Move the spindle speed lever to the 75 RPM position, the range lever to the red-dot position, and the lead screw lever to the neutral position as shown in **Figure 7**.
4. Rotate the red emergency stop button (**Figure 7**) clockwise so it pops to the outward position.

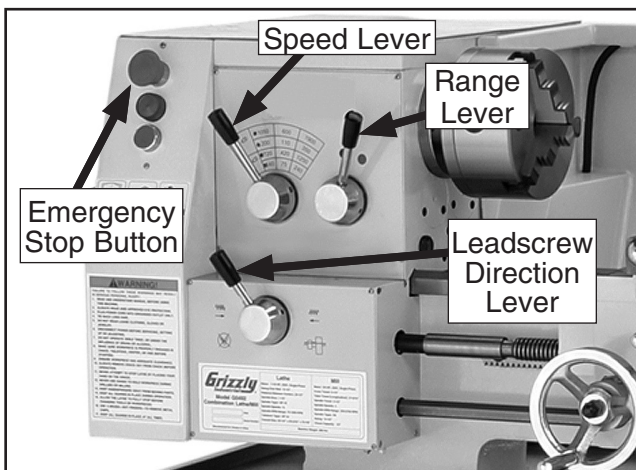

Figure 7. Headstock control levers.

5. Move the half-nut lever upward to disengage the apron, and move the feed lever to the neutral or central position (see **Figure 8**).
6. Move the spindle rotation ON/OFF lever to its central position (**OFF**) as shown in **Figure 8**, and connect the lathe to power so the green lamp is lit.

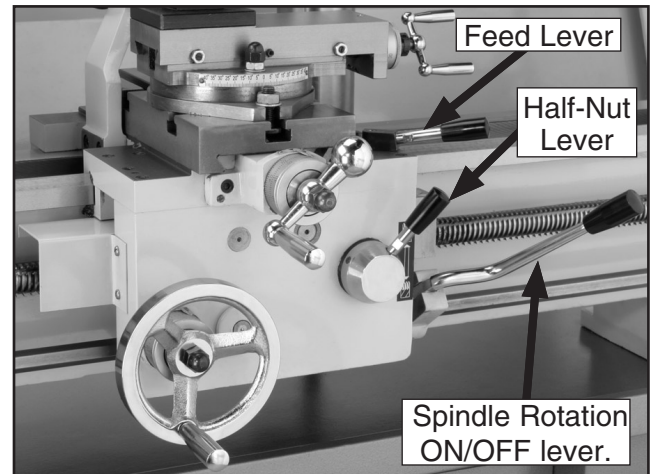

Figure 8. Apron control levers.

7. Move the spindle rotation ON/OFF lever up or down so the chuck turns, then push the emergency stop button to make sure the lathe stops.
8. Move the spindle rotation ON/OFF lever to neutral, reset the red emergency stop button, and use the spindle lever to start the lathe again.

—If you hear squealing or grinding noises, turn the machine **OFF** immediately and correct any problem before further operation.

—If the problem is not readily apparent, refer to **Troubleshooting** on **Page 43**.

9. Let the lathe/mill run for a minimum of 10 minutes.
10. Turn the lathe/mill OFF, move levers to the next highest RPM and repeat this step for each RPM setting in Low and High range. NEVER SHIFT LATHE/MILL GEARS WHEN MACHINE IS OPERATING.
11. Change the lubricant in the headstock with Mobil DTE® Oil or with an equivalent.



Mounting the Chuck and the Faceplate

The three-jaw scroll chuck has hardened steel jaws that self-center the workpiece within 0.002"-0.003". An extra set of jaws is included for machining larger workpieces.

The four-jaw chuck also has hardened steel jaws but are adjusted independently to hold an off-center workpiece. Each jaw can be removed from the chuck body and reversed for special clamping applications.

The cast-iron faceplate has slots for T-bolts that hold clamping fixtures. This face plate and after-market clamping hardware will hold non-cylindrical parts such as castings for many types of turning operations.

Both chucks and the faceplate are removed and installed the same way.

To remove and install the chuck or face plate:

1. DISCONNECT POWER TO THE LATHE/MILL!
2. Lay a chuck cradle or protective layer of plywood over the bedways to prevent your fingers from being pinched and to protect the precision-ground surfaces (see **Figure 9**).

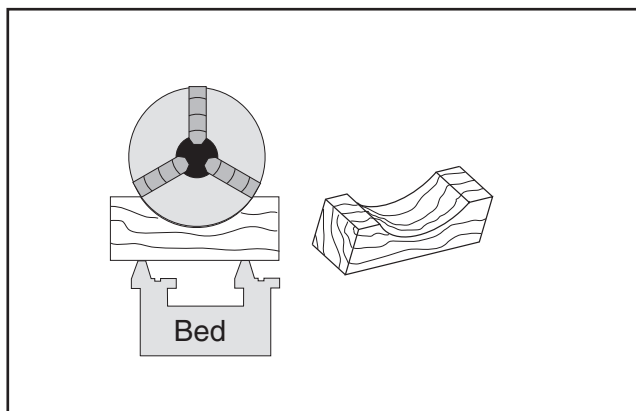

Figure 9. Simple chuck cradle made of scrap lumber.

3. Use a 14mm wrench and loosen the three hex bolts that secure the chuck to the spindle **Figure 10**.



Figure 10. Chuck mounting components.

4. Support the chuck, and while anticipating the heavy weight of the chuck, remove the three hex bolts and then the chuck.
5. Clean the mating surfaces of the spindle and the new chuck or faceplate with a clean oiled rag.
6. Position the other chuck or faceplate on the spindle flange, making sure it is fully seated, and tighten the hex bolts in several alternating sequences.

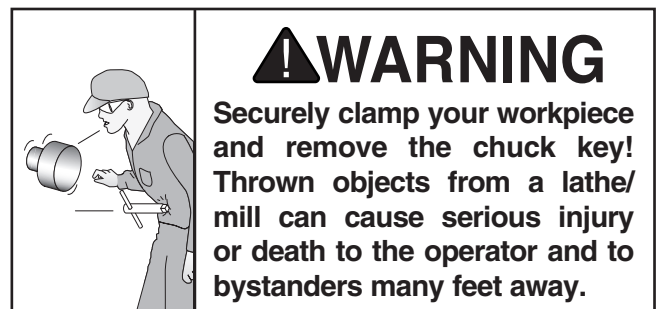

Replacing the Jaws

The three-jaw scroll chuck has removable hardened steel jaws (**Figure 11**). The outside of the jaws are used to hold the workpiece from the outer diameter.



Figure 11. Chuck and jaw selection.

Numbered from 1–3, the jaws must be used in the matching numbered jaw guides, see **Figure 12**.

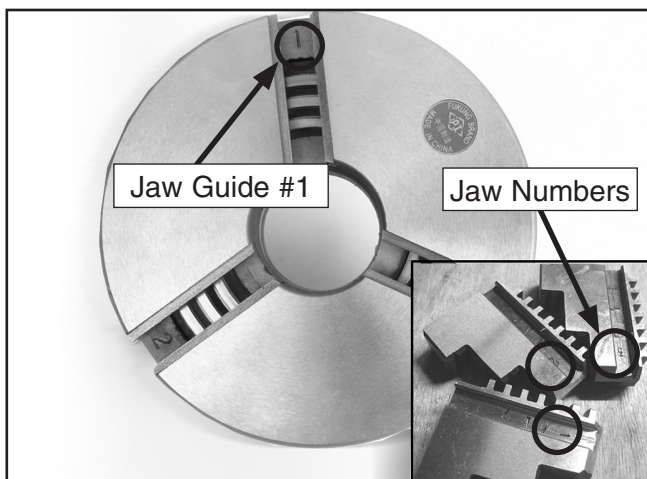

Figure 12. Jaw guide number.

Note: The chuck need not be removed from the spindle to swap the jaws.

To remove a set of jaws:

1. DISCONNECT POWER TO THE LATHE/MILL!
2. Place a piece of wood over the ways to protect them from potential damage.
3. Turn the chuck key counterclockwise and back the jaws out.
4. Clean the jaw mating surfaces and apply a film of white lithium grease to the mating surfaces.
5. Set the old jaws aside in a safe place free of moisture and abrasives.
6. Rotate the chuck key clockwise until you see the tip of the scroll-gear lead thread just begin to enter jaw guide #1 (see **Figure 13**).



Figure 13. Lead thread on scroll gear.

7. Insert jaw #1 into jaw guide #1 and hold the jaw against the scroll gear.
8. Rotate the chuck key clockwise one turn to engage the tip of the scroll-gear lead thread into the jaw. Pull on the jaw now and it should be locked into the jaw guide.
9. Repeat the steps on the remaining jaws.
 - If installed correctly, the three jaws will converge together at the center of the chuck.
 - If the jaws do not come together, repeat this procedure until they do.



Using the Four-Jaw Chuck

To install the four-jaw chuck:

Refer to the **Mounting the Chuck and Faceplate** procedures on **Page 17** to mount the four-jaw chuck.

To load a workpiece in the four-jaw chuck:

1. DISCONNECT POWER TO THE LATHE/MILL!
2. Using the chuck key, open each jaw so the workpiece will lay flat against the chuck face.
3. Support the workpiece.
4. Lock the tailstock and then turn the tailstock quill so the dead center makes contact or is close to the center point of your workpiece (see **Figure 14**).



Figure 14. Clamping workpiece.

5. Turn each jaw until it just makes contact with the workpiece.
6. In an opposing pattern, tighten each jaw in small increments. After you have adjusted the first jaw, continue tightening the opposing jaw. Check the dead center alignment frequently to make sure you have not wandered off your index point due to applying too much pressure to a single jaw.
7. After the workpiece is held in place, back the tailstock away and rotate the chuck by hand. The center point will move if the workpiece is out of center.
8. Make fine adjustments by slightly loosening one jaw and tightening the opposing jaw until the workpiece is precisely aligned. Use a dial indicator for fine tuning adjustments in alignment (see **Figure 15**).

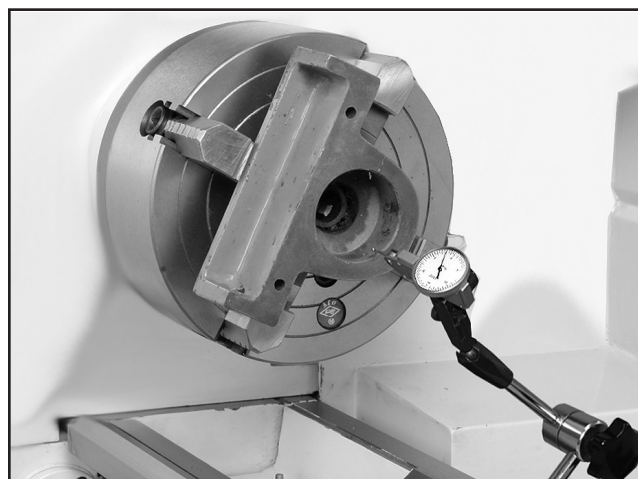
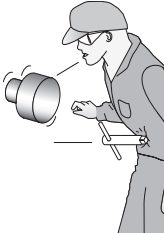

Figure 15. Centering workpiece.

9. Use a lower RPM when machining heavy eccentric workpieces.

	<p>! WARNING</p> <p>Securely clamp your workpiece and remove the chuck key! Thrown objects from a lathe/mill can cause serious injury or death to the operator and to bystanders many feet away.</p>
--	---



Using the Faceplate

The faceplate can be used to turn non-cylindrical parts or for off-center turning by clamping the workpiece to the faceplate.

To install the faceplate:

Refer to the **Mounting the Chuck and Faceplate** procedures on **Page 17** to mount the faceplate.

To load a workpiece:

1. Support the workpiece.
2. Slide the tailstock to the workpiece.
3. Lock the tailstock and then turn the tailstock quill so the dead center makes contact with the center point of your workpiece.
4. Lock the tailstock quill when sufficient pressure is applied to hold the workpiece in place.

Note: Depending on the workpiece, some additional support may be needed.

5. Secure the workpiece with a minimum of three independent clamping devices. Failure to follow this step may lead to deadly injury to yourself or bystanders. Take into account rotation and the cutting forces applied to the workpiece when clamping to the faceplate. **Make sure your clamping application will not fail!**
6. Use a lower RPM when machining heavy eccentric workpieces.

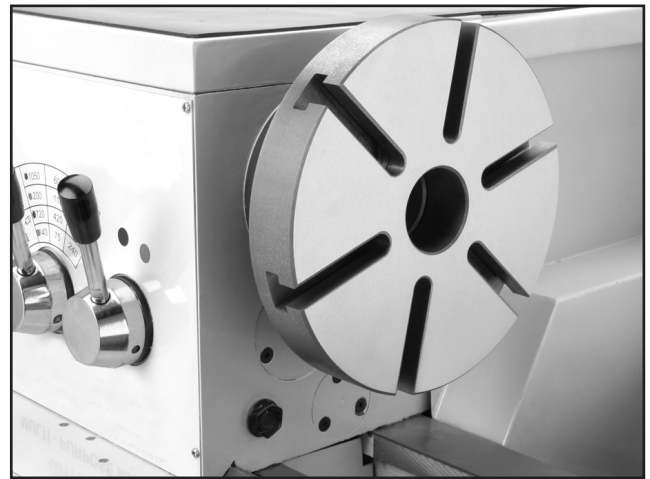
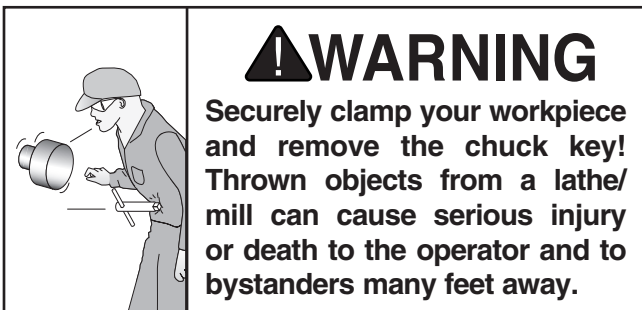

Figure 16. Faceplate installed.

!WARNING

Use a minimum of three independent clamping devices when turning eccentric workpieces. Failure to provide adequate clamping will cause workpiece to eject.



Using the Tailstock

The tailstock (**Figure 17**) can be used to support workpieces with the use of a live or dead center. Using an MT#3 drill chuck and a drill bit, the lathe can drill or bore holes in the center of a part. The tailstock can also be offset for cutting shallow tapers.

To use the tailstock:

1. Slide the tailstock to the desired position.
2. Pull up on the tailstock lock lever to lock the tailstock in place on the ways.
3. With the tailstock locked, push down the quill lock lever to unlock.
4. Turn the quill feed handle clockwise to feed/move the quill towards the spindle, or counterclockwise to move away from the spindle.
5. Turn the quill lock lever to lock the quill in place.

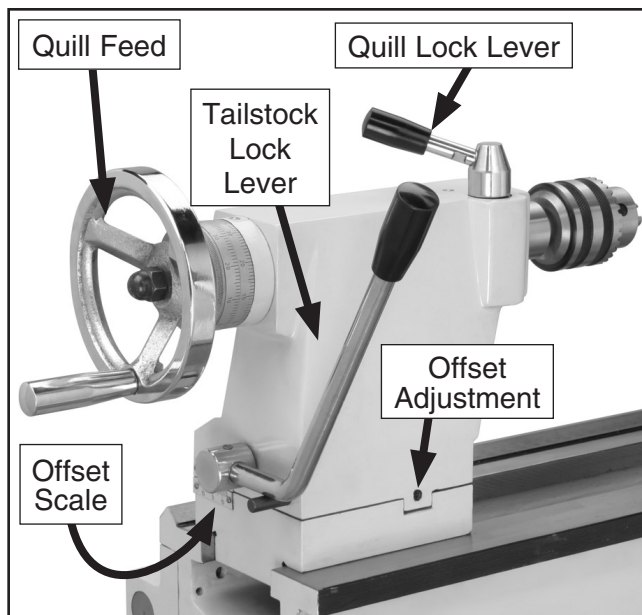

Figure 17. Tailstock and quill lock handles in locked position.

Drilling with the Tailstock

To install the MT#3 drill chuck:

1. With the tailstock locked, unlock the quill lock lever.
2. Turn the quill feed handle clockwise to extend the quill about one inch.
3. Insert the MT#3 chuck (**Figure 18**) or an MT#3 tapered drill shank into the quill until the taper is firmly seated.
4. Turn the quill feed handle clockwise to feed the drill bit into a rotating workpiece.
5. To remove the chuck taper, turn the quill feed handle counterclockwise until the chuck is pushed out of the tailstock taper.



Figure 18. Setting up tailstock for drilling.



Cutting Shallow Tapers with Tailstock

To setup the tailstock to cut tapers:

1. Lock the tailstock in position.
2. Alternately loosen and tighten the left and right offset adjustment screws until the desired offset is indicated on the scale (see **Figures 19 & 20**).
3. Retighten the lock screw.

Note: To return the tailstock back to the original position, repeat the process until the centered position is indicated on the scale.

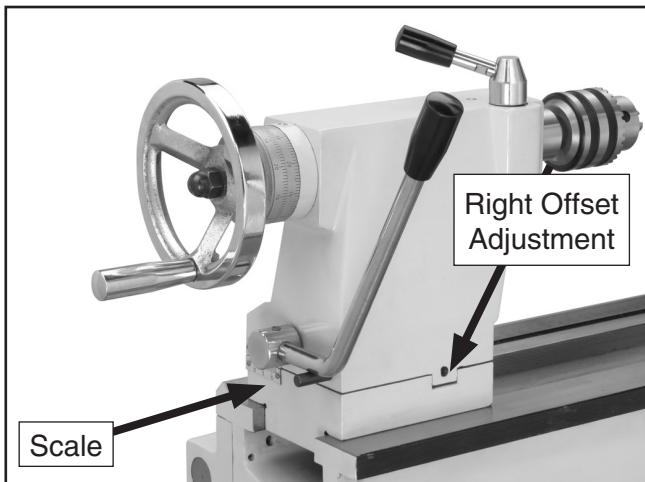

Figure 19. Right offset adjustment.

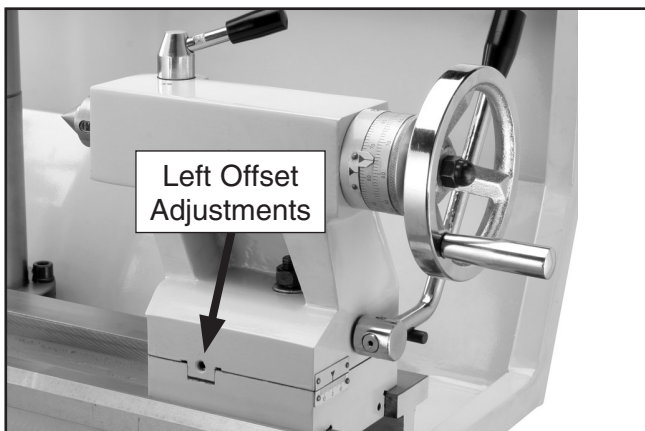

Figure 20. Left offset adjustment.

Aligning Tailstock

The tailstock is aligned at the factory with the headstock. We recommend that you take the time to ensure that the tailstock is aligned to your own desired tolerances.

To align the tailstock:

1. Using a precision level on the bedways, make sure the lathe/mill is level side-to-side and front-to-back. If the lathe/mill is not level, correct this condition before proceeding.
2. Get two pieces of steel round stock, two inches in diameter and six inches long.
3. Center drill both ends of one piece of the round stock. Set it aside for use in **Step 6**.
4. Using the other piece of stock, make a dead center by turning a shoulder to make a shank. Flip the piece over in the chuck and turn a 60° point (see **Figure 21**).

Note: As long as the dead center remains in the chuck, the point of your center will remain true to the spindle axis. Keep in mind that the point will have to be refinished whenever it is removed and returned to the chuck.

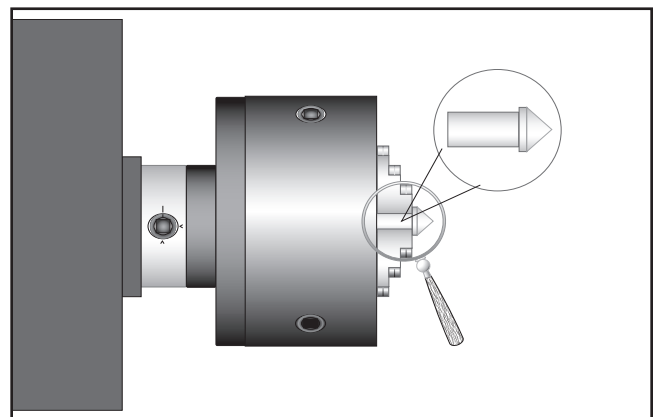

Figure 21. Tailstock centering dead center.



5. Place the live center in the tailstock.
6. Attach a lathe/mill dog to the bar stock and mount it between centers.
7. Turn approximately 0.010" off the diameter.
8. Measure the stock with a micrometer.

—If the stock diameter is thicker at the tailstock end, the tailstock needs to be moved toward you half the distance of the amount of the taper (see **Figure 22**).

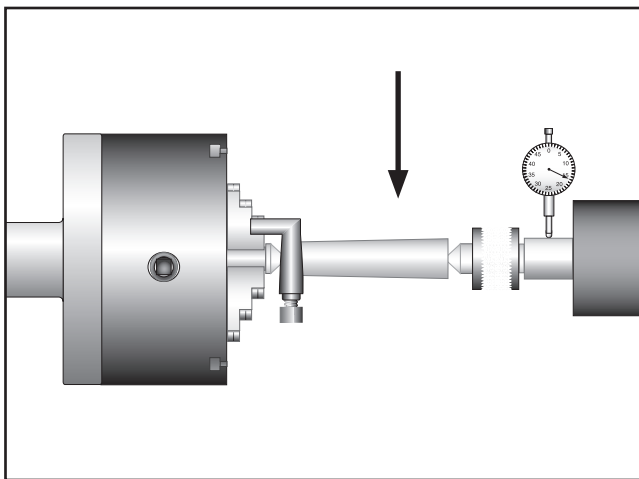

Figure 22. Tailstock adjustment option #1.

—If the stock diameter is thinner at the tailstock end, the tailstock needs to be moved away from you half the distance of the amount of the taper (see **Figure 23**).

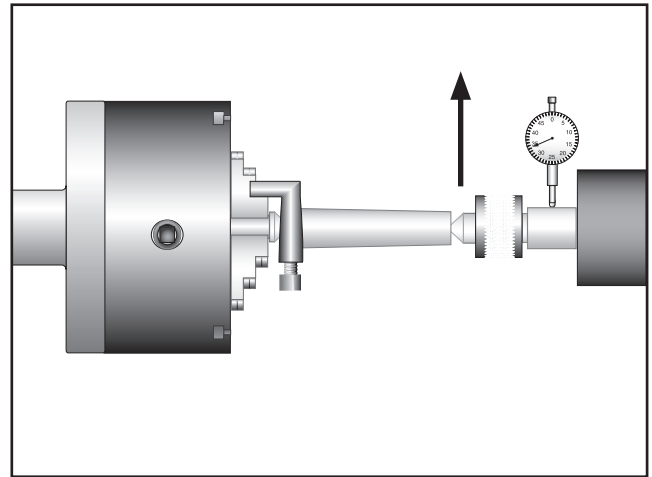

Figure 23. Tailstock adjustment option #2.

9. Mount a dial indicator so the dial plunger is on the tailstock barrel before making adjustments to the tailstock.
10. Turn another 0.010" off of the diameter and check for a taper. Repeat this process as necessary until the desired amount of accuracy is achieved.



Using the Centers

The dead center is used in the tailstock and lathe spindle to support workpieces. When used in the tailstock, make sure to keep the MT#3 dead center tip and workpiece lubricated to prevent tip galling.

This lathe/mill is also supplied with an MT#5 dead center that fits into the lathe spindle taper.

To install a dead or live center:

1. Feed the quill out about 1" and insert the MT#3 dead center (**Figure 24**). The mating tapers provide the locking action.

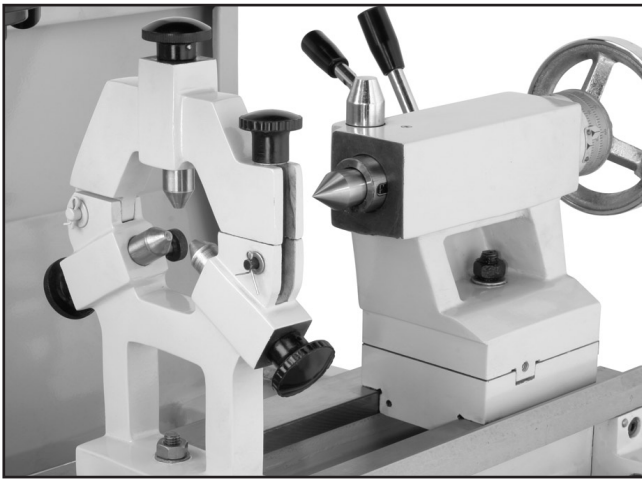

Figure 24. Inserting dead center.

2. Move the tailstock into position and lock in place.
3. Feed the quill into the workpiece.

Note: Make sure there is a center drilled hole in the end of the workpiece for the dead center.

4. Lock the quill into place once the live center and the part rotate together. The quill may need to be adjusted during operation.
5. To remove the dead center, retract the quill until the dead center pops free.

To install the MT#5 dead center in the spindle:

1. DISCONNECT POWER TO THE LATHE/MILL!
2. Remove the chuck from the spindle.
3. Install the MT#5 dead center in the spindle.
4. Attach the faceplate to the spindle, see **Figure 25**.

Note: When using the dead center in the spindle, use a lathe dog so that your part will rotate with the spindle and not spin on the dead center tip.



Figure 25. Faceplate and dead center setup.

NOTICE

Failure to keep dead center point well lubricated will gall the dead center and workpiece.



Using the Steady Rest

The steady rest serves as a support for long shafts. The steady rest can be placed anywhere along the length of the ways.

To use the steady rest:

1. Carefully place the steady rest on the lathe bedways.
2. Loosen the lock knobs so the finger position can be adjusted (see **Figure 26**).

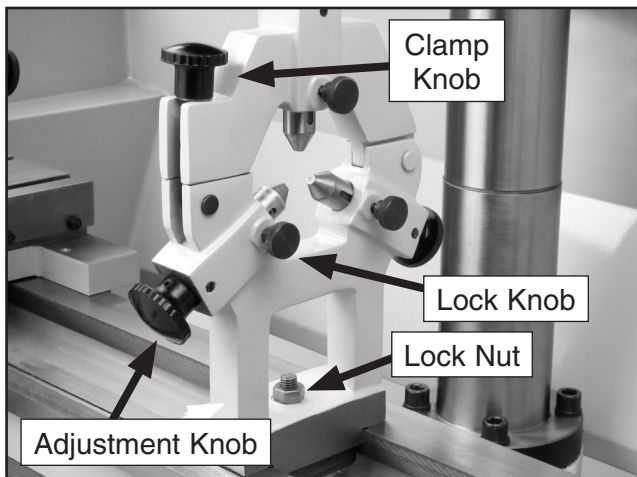

Figure 26. Steady rest adjustments.

3. Loosen the clamp knob (see **Figure 26**) and open the steady rest so a workpiece can fit inside of the fingers.
4. Position the steady rest where desired. Tighten the lock nut (see **Figure 26**) at the base of the steady rest to secure in place.
5. Close the steady rest so that the workpiece is inside the fingers and tighten the clamp knob.
6. Turn the adjustment knobs so the fingers are snug against the workpiece and then tighten the lock knobs. Lubricate the finger tips with an anti-seize lubricant during operation.
7. After prolonged use, the fingers will show wear. Either mill or file the tips for a new contact surface.

Using the Follow Rest

The follow rest in **Figure 27** is mounted on the saddle and follows the movement of the tool. The follow rest requires only two fingers, as the cutting tool acts as the third. The follow rest is used on long, slender parts to prevent flexing of the workpiece from the pressure of the cutting tool.

The sliding fingers are set similar to those of the steady rest—free of play but not binding. Always lubricate during operation. After prolonged use, the fingers will need to be milled or filed to clean up the contact surface.

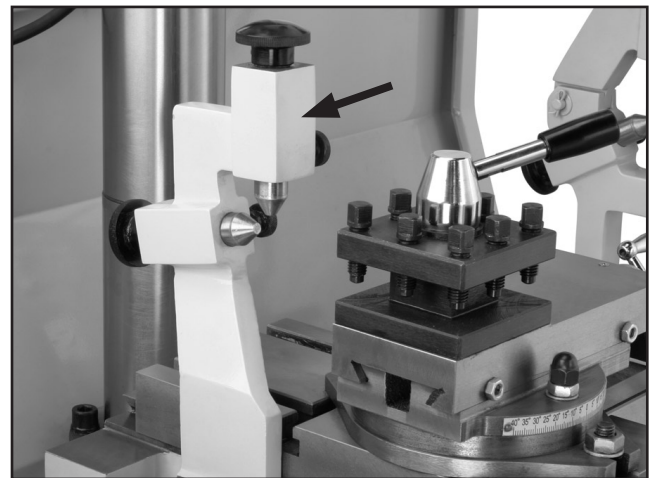

Figure 27. Follow rest attachment.



Using the Compound Rest

The compound rest is used to cut tapers on parts or to set the proper infeed angle when threading. It may also be used to cut specific lengths longitudinally, when set parallel to the spindle axis.

To set the angular position:

1. Loosen the hex nuts, one on each side of the compound rest (see **Figure 28**).
2. Rotate the compound rest to the desired angular position using the scale.
3. Tighten the two hex nuts. Be sure to not over-tighten, as you may strip threads or crack or distort the base casting.

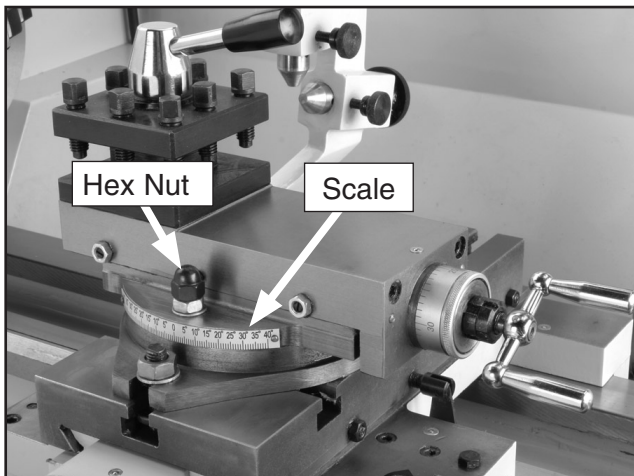

Figure 28. Compound rest, scale, and handwheel.

Using the Tool Post

The four-way tool post (**Figure 29**) is mounted on top of the compound rest, and allows a maximum of four tools to be loaded simultaneously.

The four-way tool post allows for quick indexing to new tools. This is accomplished by rotating the top handle counterclockwise and then rotating the tool post to the desired position. Rotate the top handle clockwise to lock the tool into position.

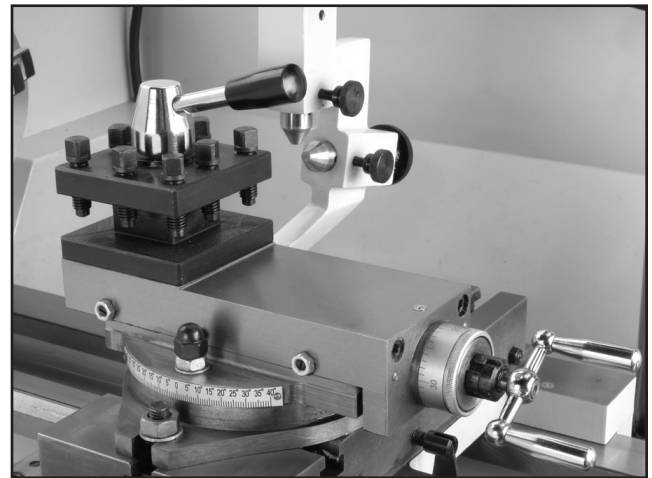

Figure 29. Four-way tool post.



Using the Manual Feed Handwheels

You can manually move the cutting tool around the lathe/mill with the three handwheels shown in **Figure 30**.

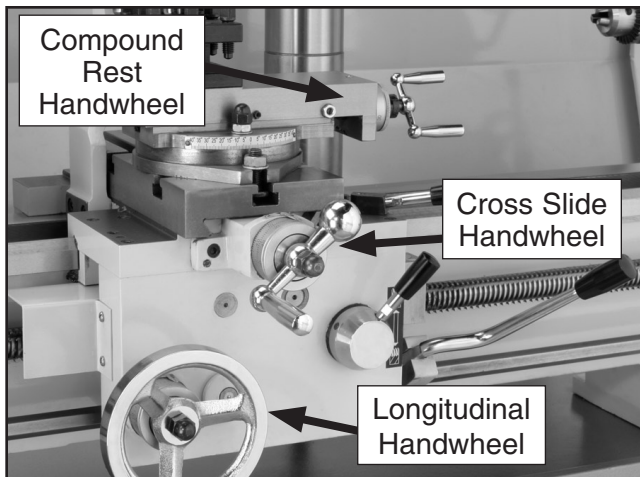

Figure 30. Carriage controls.

Longitudinal Handwheel

The longitudinal handwheel moves the carriage left or right along the bed. This control is helpful when setting up the machine for turning or when manual movement is desired during turning operations.

Cross Slide Handwheel

The cross slide handwheel moves the top slide toward and away from the work. Turning the dial clockwise moves the slide toward the workpiece.

Compound Rest Handwheel

The compound rest handwheel controls the position of the cutting tool relative to the workpiece. The graduated dial is adjustable using the same method as the dial on the cross slide. Angle adjustment is held by two hex nuts on the base of the compound rest.

Setting the Spindle RPM

To determine and set the needed spindle RPM for cutting:

1. Use the table in **Figure 31** to determine the cutting speed required for the workpiece material.

Cutting Speeds for High Speed Steel (HSS) Cutting Tools	
Workpiece Material	Cutting Speed (sfm)
Aluminum & alloys	300
Brass & Bronze	150
Copper	100
Cast Iron, soft	80
Cast Iron, hard	50
Mild Steel	90
Cast Steel	80
Alloy Steel, hard	40
Tool Steel	50
Stainless Steel	60
Titanium	50
Plastics	300-800
Wood	300-500

Note: For carbide cutting tools, double the cutting speed. These values are a guideline only. Refer to the *MACHINERY'S HANDBOOK* for more detailed information.

Figure 31. Cutting speed table for HSS cutting tools.

!WARNING

Failure to follow RPM and feed rate guidelines may threaten operator safety from ejected parts or broken tools.



2. Determine the average final diameter of the workpiece in inches, for the cut to be made.
3. Now use the following formula to determine the closest RPM for the cutting operation:

$$\frac{(\text{Cutting Speed} \times 4)}{\text{Diameter of Cut}} = \text{RPM}$$

4. With the calculated RPM, decide on the closest cutting RPM to what you need.
5. Make sure the spindle is completely stopped before proceeding.
6. Move the levers (**Figure 32**) to get the RPM range that is closest to your calculated RPM:

- The range lever selects BLACK DOT = High or RED DOT = Low.
- The RPM Lever selects the RPM within that range.

Note: You may need to rotate the chuck by hand to get the gears to engage.

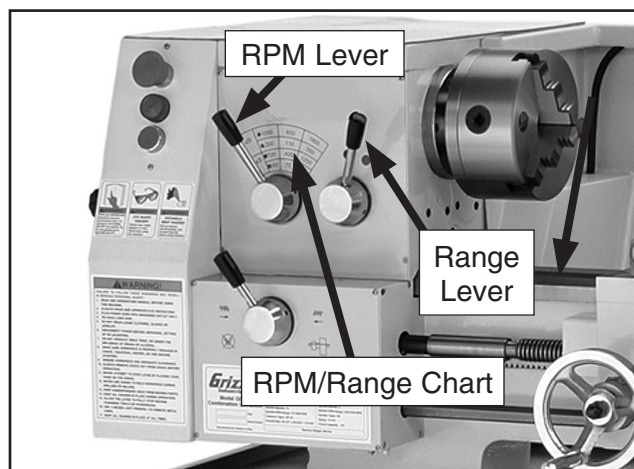

Figure 32. Spindle speed selector levers.



Setting the Power Feed Rate

The carriage has longitudinal and cross slide power feed capabilities. All directions reverse when spindle rotation is reversed.

NOTICE

Feed rate is based on spindle RPM. Pay close attention to the feed rate you have chosen and be ready to disengage the apron. Failure to do this may cause the carriage to crash into the chuck.

To set and engage the power feed:

1. DISCONNECT THE LATHE/MILL FROM POWER!
2. Refer to the **Change Gear Chart** on **Page 31** to determine the needed combination of gears and which spindle location to install each gear on. See **Figure 33** for the gear installation locations that are referenced by the chart.

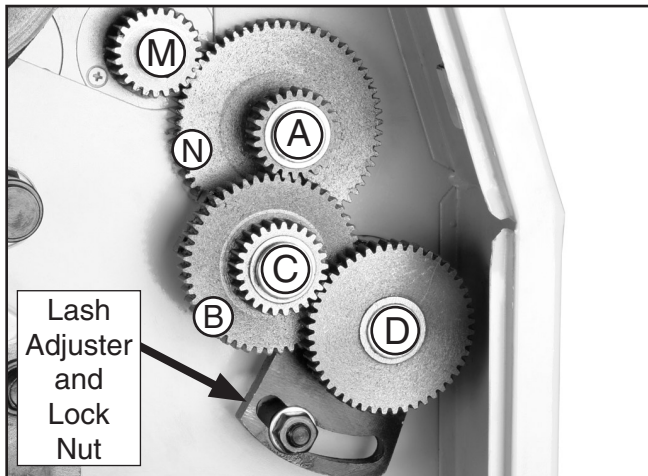

Figure 33. Change gear locations.

3. See **Figure 34** for an example of gear combinations that give the longitudinal and cross slide rates. For example: The chart shows that 0.0089" of longitudinal travel per revolution of lead screw is needed, or 0.0019" of cross travel per revolution of lead screw is needed.

Note: All change gears are stamped with the number of teeth they have.

4. Loosen the lash adjuster (**Figure 33**) and swing the assembly out of the way.
5. Remove the required E-clips, lubricate, and swap out the appropriate change gears.
6. Move the lash adjuster so the gear backlash is at 0.003" to 0.008", and tighten the lock nut.
7. Use the leadscrew lever to select leadscrew rotation direction (**Figure 35**).
8. Loosen the apron lock bolt, and use the feed lever (**Figure 35**) to engage the cross slide or longitudinal feed.

Inch Threading		Longitudinal Feed		Cross Feed	
M = 24	M = 28	A	B	C	D
N = 60	N = 35	X	Y	Z	W
24	25	24	25	24	25
50	48	X	Y	Z	W
10	5	48	30	0.0040	0.0080
12	6	40	30	0.0072	0.0344
16	8	35	30	0.0130	0.0260
18	9	40	25	0.0115	0.0230
20	10	32	30	0.0103	0.0206
22	11	32	25	0.0094	0.0188
23	11.5	25	32	0.0089	0.0178
24	12	25	32	0.0086	0.0173
25	12.5	25	32	0.0082	0.0164
26	13	25	32	0.0079	0.0158
28	14	25	30	0.0074	0.0148
30	15	24	30	0.0069	0.0139
32	16	25	30	0.0065	0.0130
34	17	25	24	0.0061	0.0122

Figure 34. Using the change gear chart.

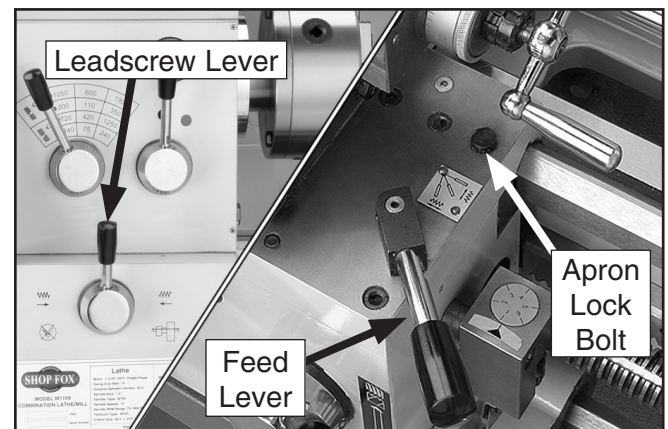

Figure 35. Leadscrew and feed levers.



Setup for Threading

Your lathe is capable of cutting inch and metric threads.

To setup for threading:

1. DISCONNECT THE LATHE/MILL FROM POWER!
2. Refer to the **Change Gear Chart** on **Page 31** or the chart on the inside of the change gear door to determine the needed combination of gears and which spindle location to install each gear on.

See **Figure 36** for examples of how gear combinations can achieve your needed threading rate. For example: The chart shows that 24 TPI is needed.

Note: All change gears are stamped with the number of teeth they have.

6. Use the leadscrew lever to select leadscrew direction (**Figure 37**).
7. Setup the cutting tool, compound rest, and cross slide to cut your threads; and loosen the apron lock (**Figure 35**).

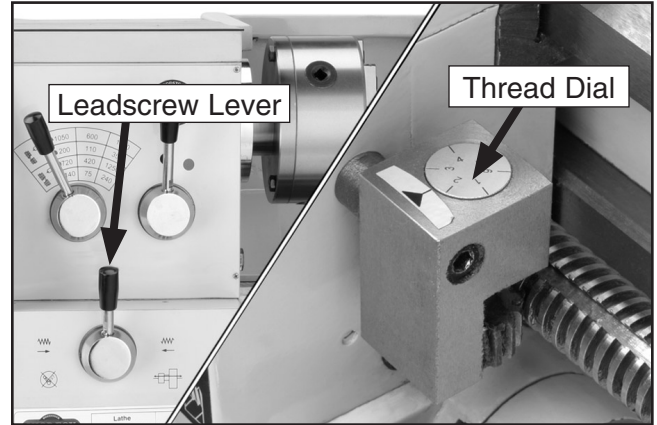

Figure 37. Threading controls.

—If cutting inch threads, refer to the **Thread Dial Table** in **Figure 38** to use the thread dial.

—If cutting metric threads, do not use the thread dial. Instead, you must leave the half nut engaged until the threading operation is totally complete.

Inch Threading		Longitudinal Cross Feed			
M	N	A	B	C	D
M = 24	M = 28				
N = 60	N = 35				
10	5	24	X	25	48
12	6	48	X	30	32
15	8	36	X	30	32
18	9	40	X	25	48
20	10	32	X	30	48
22	11	32	X	25	44
24	11.5	25	X	32	46
25	12.5	25	X	32	46
26	13	25	X	32	46
28	14	25	X	30	48
30	15	24	X	30	48
32	16	25	X	30	48
34	17	25	X	24	48

Figure 36. Using the change gear chart.

3. Loosen the lash adjuster (**Figure 33**) and swing the assembly out of the way.
4. Remove the required E-clips, lubricate, and swap out the appropriate change gears.
5. Move the lash adjuster so the gear backlash is at 0.003" to 0.008", and tighten the lock nut.

THREAD DIAL TABLE			
LEAD SCREW PITCH 5 T.P.I.			
T.P.I.	DIAL	T.P.I.	DIAL
5	1-6	18	1 or 2
6	1 or 2	20	
7	1	22	1 or 2
8	1	23	1
9	1	24	1 or 2
10	1-6	25	1-6
11	1	26	1 or 2
11.5		28	1 or 2
12	1 or 2	30	1-6
12.5		32	1 or 2
13	1	34	1 or 2
14	1 or 2	36	1 or 2
15	1-6	40	1-6
16	1 or 2	48	1 or 2
17	1		

Figure 38. Thread dial table.

8. Loosen the apron lock bolt and use the feed lever (**Figure 35**).
9. While threading, keep your hand on the half-nut lever, ready to disengage the apron to avoid any potential for an apron/chuck crash.



Change Gear Chart

M = 24		M = 28		mm		mm	
N = 60		N = 35		M = 24 N = 60		M = 28 N = 35	
A		B		C		D	
10	5	48	30	42	36	0.100	0.200
12	6	40	30	42	36	0.618	1.236
16	8	35	30	42	36	0.565	1.130
18	9	40	25	48	27	0.520	1.040
20	10	32	30	32	34	0.465	0.930
22	11	32	25	36	35	0.412	0.824
23	11.5	25	32	36	42	0.360	0.720
24	12	25	32	35	42	0.310	0.620
25	12.5	25	32	28	34	0.260	0.520
26	13	25	32	35	44	0.200	0.400
28	14	25	30	25	30	0.182	0.364
30	15	24	30	25	30	0.164	0.328
32	16	25	30	25	24	0.154	0.308
34	17	25	24	25	28	0.145	0.290
36	18	25	24	24	28	0.122	0.245
40	20	25	24	24	50	0.105	0.210
48	24	25	25	24	50	0.093	0.186

M = 24		M = 28		mm		mm	
N = 35		N = 60		M = 24 N = 60		M = 28 N = 35	
A		B		C		D	
3	6	42	36	24	25	0.020	0.040
2.75	5.5	42	36	42	36	0.131	0.262
2.5	5	48	30	42	35	0.120	0.240
2.25	4.5	32	34	48	30	0.110	0.220
2	4	36	35	32	35	0.098	0.196
1.75	3.5	36	42	32	42	0.087	0.175
1.5	3	35	42	36	42	0.076	0.152
1.25	2.5	28	34	35	42	0.066	0.132
1	2	28	34	28	48	0.055	0.110
0.8	1.75	25	30	32	48	0.044	0.088
0.75	1.5	25	30	25	48	0.038	0.076
0.7	0.7	25	28	25	48	0.035	0.070
0.6	0.6	24	28	25	48	0.032	0.064
0.5	1	24	27	25	48	0.030	0.060
0.45	0.45	24	24	24	50	0.026	0.052
		24	50	24	52	0.022	0.044
		24	50	24	52	0.019	0.038

M = 24		M = 28		mm		mm	
N = 60		N = 35		M = 24 N = 60		M = 28 N = 35	
A		B		C		D	
10	5	48	30	0.0040	0.0080	0.0008	0.0017
12	6	40	30	0.0206	0.0412	0.0044	0.0088
16	8	35	30	0.0172	0.0344	0.0036	0.0072
18	9	40	25	0.0130	0.0260	0.0028	0.0056
20	10	32	30	0.0115	0.0230	0.0024	0.0048
22	11	32	25	0.0103	0.0206	0.0022	0.0044
23	11.5	25	32	0.0094	0.0188	0.0020	0.0040
24	12	25	32	0.0089	0.0178	0.0019	0.0038
25	12.5	25	32	0.0086	0.0172	0.0018	0.0036
26	13	25	32	0.0082	0.0164	0.00175	0.0035
28	14	25	30	0.0079	0.0158	0.0017	0.0034
30	15	24	30	0.0074	0.0148	0.0016	0.0032
32	16	24	30	0.0069	0.0138	0.0015	0.0030
34	17	25	24	0.0065	0.0130	0.0014	0.0028
36	18	25	24	0.0061	0.0122	0.0013	0.0026
40	20	25	24	0.0057	0.0114	0.0012	0.0024
48	24	25	24	0.0052	0.0104	0.0011	0.0022
		25	25	0.0043	0.0086	0.0009	0.0018

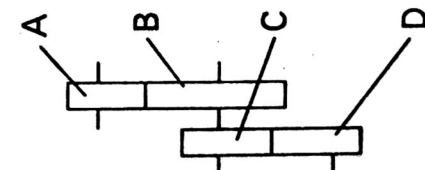
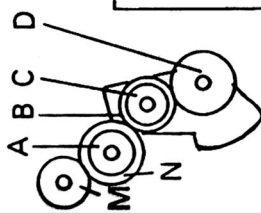

SECTION 5: MILL OPERATIONS

Test Run & Break-In

NOTICE

Failure to follow start up and spindle break-in procedures will cause rapid deterioration of spindle and other related parts, and never shift gears while lathe or mill is running.

It is essential to closely follow the proper break-in procedures to ensure trouble free performance. Complete this process once you have familiarized yourself with all instructions in this manual.

To begin the start up procedure:

1. Make sure the mill has been properly lubricated.
2. Make sure there are no obstructions around or underneath the spindle.
3. Set the spindle speed to 240 RPM.
4. Turn the mill **ON** (Figure 39).

5. Turn the spindle **ON** and run it a minimum of 10 minutes. Repeat this step on the other three RPM ranges.

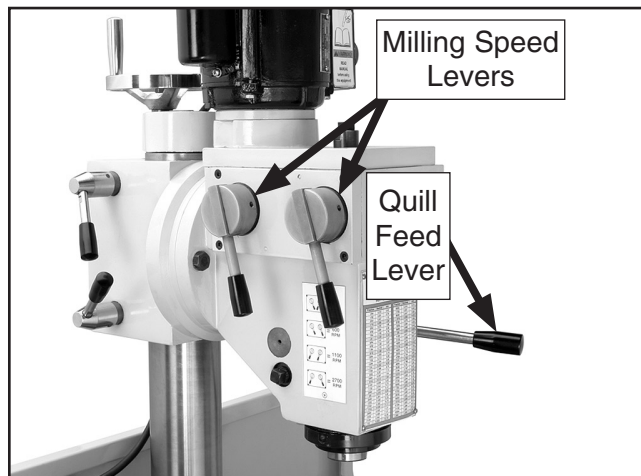

Figure 40. Gearbox and controls.

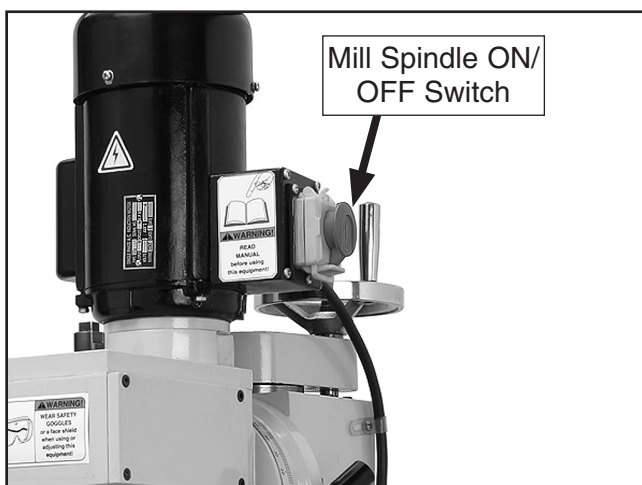

Figure 39. Start switch location.



Positioning the Headstock

The mill headstock head can be raised and lowered vertically, or rotated left or right up to 90° degrees to position the cutting tool next to the workpiece.

To position the spindle head vertically:

1. Make sure the spindle is stopped and the work area is free from obstructions before proceeding.
2. Loosen both column lock levers so that the headstock can freely slide on the column (**Figure 41**).
3. Rotate the mill height handwheel (**Figure 41**) to raise or lower the headstock to the desired position then lock the levers.

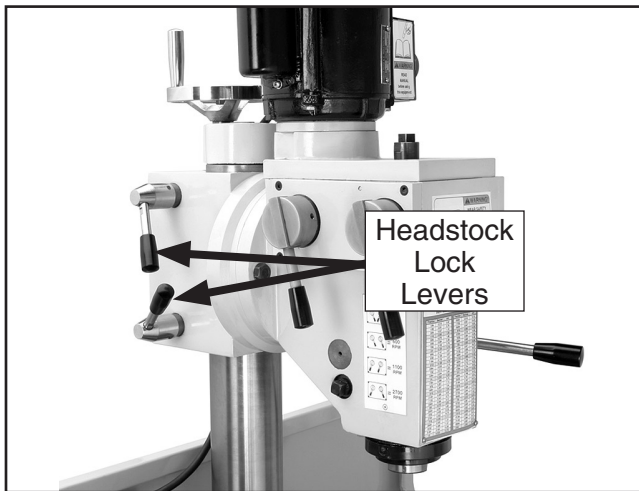

Figure 41. Headstock lock levers.

⚠️ WARNING

The headstock is heavy. Make sure that you support the headstock before you loosen the lock nuts. Ignoring this warning may allow the headstock to uncontrollably swing over to the right or left causing injury or severe lathe/mill damage.

4. While supporting the headstock, use a 17mm wrench and loosen both left and right headstock tilt lock nuts (**Figure 42**), then tilt the headstock to your desired angle. Retighten the lock nuts.

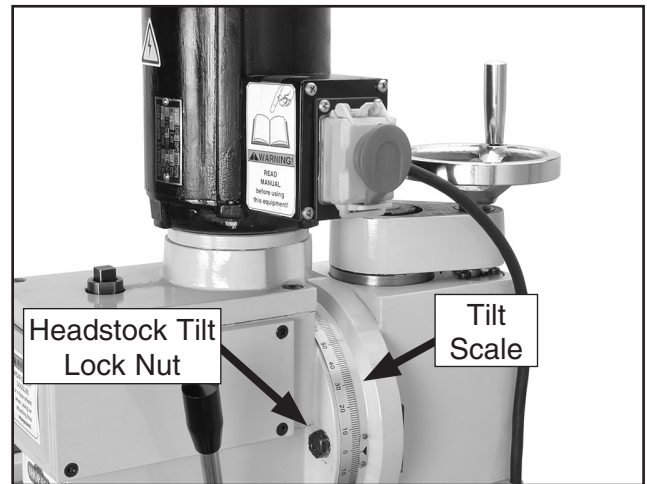

Figure 42. Headstock lock nut.

Using the Mill Table

The mill table of the Model G0492 can be moved in two axes—cross slide and longitudinal feed. Each of these axes are controlled by graduated handwheels to accurately position the workpiece in relation to the tool. To set the power feed for milling, refer to **Setting Power Feed Rate** on **Page 29**.

Cross Slide

The cross slide is controlled by the cross slide handcrank of the lathe shown in **Figure 43**.

Longitudinal Feed Control

The longitudinal feed is controlled by the longitudinal handwheel of the lathe, and the lock at the back of the saddle (see **Figure 43**).

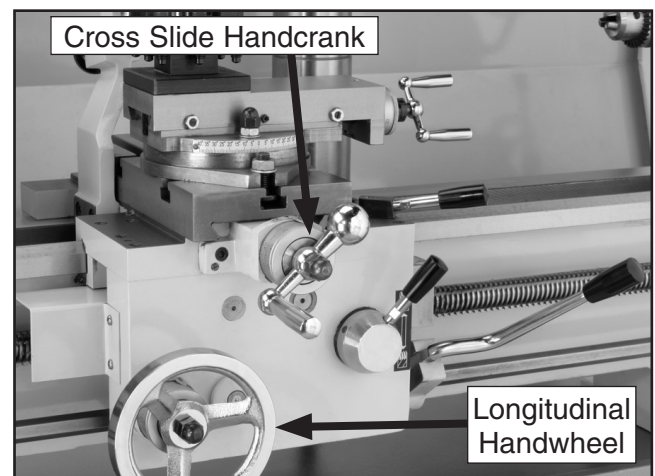

Figure 43. Headstock and apron controls.



Installing Cutters

To install a cutter in the spindle:

1. DISCONNECT THE LATHE/MILL FROM POWER!
2. Carefully clean the surface of the arbor and spindle taper. Ensure that they are free of debris and burrs.
3. Insert the arbor into the spindle, and rotate the arbor so the slot in the arbor lines up with the pin inside of the spindle.
4. Press the arbor up firmly to seat it with the spindle.
5. Finger tighten the drawbar into place (**Figure 44**), then use a 12mm wrench to tighten the drawbar (**Figure 45**).

Note: *Overtightening the drawbar makes removal difficult and stretches the threads of the arbor and the drawbar.*



Figure 44. Aligning drawbar with chuck arbor.



Figure 45. The drawbar.

6. Clear away all items from the cutting tool before turning the mill **ON**.

Removing Cutters

To remove a cutter from the spindle:

1. DISCONNECT THE LATHE/MILL FROM POWER!
2. Return the headstock to the highest position and loosen the drawbar.
3. Put on leather gloves and support the chuck or collet and unthread the drawbar approximately four turns.

NOTICE

DO NOT completely unscrew the drawbar prior to striking the drawbar or the initial threads of the drawbar and tool will be crushed.

4. Lightly strike the drawbar with a dead blow hammer or a piece of wood to release the arbor from the spindle.
5. Prepare to catch the arbor, and unscrew the drawbar until the arbor drops into your hand.



Setting the Spindle RPM

NOTICE

Never shift gears while lathe or mill is running; otherwise, the gear teeth will be chipped or broken.

To determine and set the mill to the needed cutting RPM:

1. Select the cutting speed required for the material of your workpiece using the table in **Figure 46**.

Cutting Speeds for High Speed Steel (HSS) cutting tools:

Workpiece Material	Cutting Speed (sfm)
Aluminum & alloys	300
Brass & Bronze	150
Copper	100
Cast Iron, soft	80
Cast Iron, hard	50
Mild Steel	90
Cast Steel	80
Alloy Steel, hard	40
Tool Steel	50
Stainless Steel	60
Titanium	50
Plastics	300-800
Wood	300-500

Figure 46. High speed steel cutting chart.

Note: Double the cutting speed for carbide cutting tools. These values are a guideline only. Refer to the *MACHINERY'S HANDBOOK* for more detailed information.

2. Measure the diameter of your cutting tool in inches.
3. Use the following formula to determine the needed RPM for your operation:

$$(\text{Cutting Speed} \times 4) / \text{Tool Diameter} = \text{RPM}$$

Note: You will only be able to get an approximate RPM value with the variable speed knob.

4. Move the mill gearbox levers to the nearest milling speed RPM.

NOTICE

Failure to follow RPM and Feed Rate Guidelines will shorten cutter life and give poor workpiece results and may threaten operator safety from ejected parts or broken tools.

Using the Mill

The quill feed is controlled by the handle on the right of the headstock, and a lock bolt on the left side of the headstock (**Figure 47**).

To use the quill:

1. Hold a feed handle, and loosen the quill feed lock bolt to release the quill.
2. For drilling, pull the handle toward you and the quill will feed down toward the workpiece.

Note: The quill feed handle is spring loaded. **DO NOT** let go of the handle at the end of a drilling operation or the quill will quickly retract and slam into the headstock.

3. For milling, hold the quill at a particular depth and tighten the quill lock bolt.

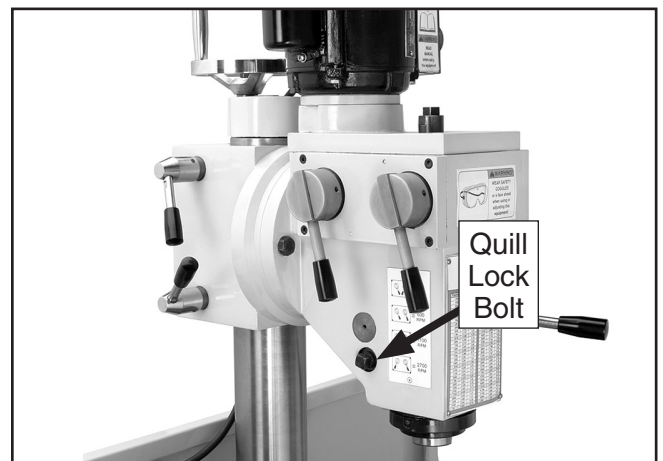

Figure 47. Quill lock.



SECTION 6: MAINTENANCE

Basic Maintenance

Regular periodic maintenance of your lathe/mill will ensure optimum performance. Make a habit of inspecting your machine each time you use it.

Check for the following conditions and repair or replace when necessary:

- Loose mounting bolts and chuck.
- Worn switch or safety features.
- Worn or damaged cords and plugs.
- Any other condition that could hamper the safe operation of this machine.

General Lubrication

Paint all gears in **Figure 48** with a good quality automotive wheel bearing grease as required to keep lubricated.

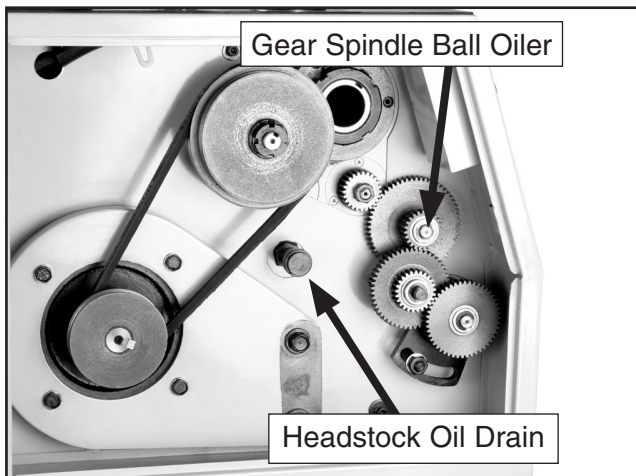

Figure 48. Headstock and gear box drain locations.

Keep the headstock oil level at $\frac{3}{4}$ full (**Figures 49 and 50**). After break-in, change the oil in the headstock with Mobil® DTE® Heavy-Medium or an equivalent grade of oil immediately and then again after three months. After that, change the oil at the same time on an annual basis or more frequently if extreme machine use requires it.

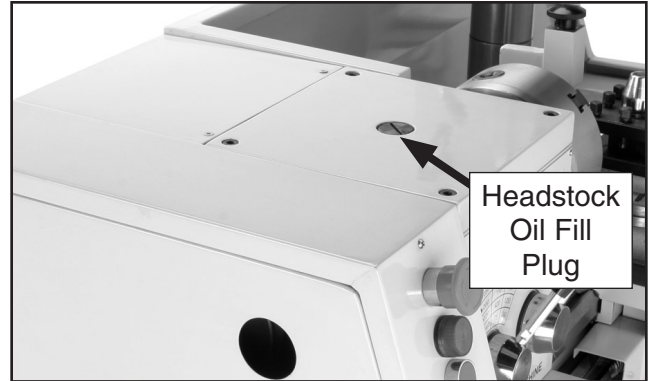

Figure 49. Headstock fill plug.

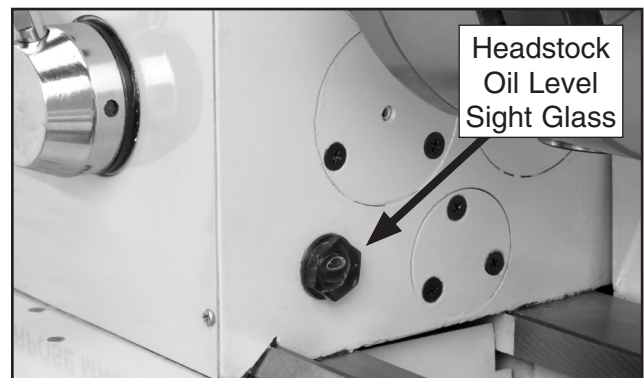

Figure 50. Headstock oil level sight glass.

General Cleaning

Clean your machine every day or more often as needed. Make sure to unplug the lathe/mill before cleaning it. Never blow the lathe/mill off with compressed air, otherwise you will force metal shavings deep into mechanisms. Remove chips as they accumulate with rags, brushes, and a shop vacuum. Chips left on the machine soaked with water-based coolant will eventually invite oxidation and a gummy residue build up around moving parts. Cleaning will help keep your lathe/mill running smoothly. Always be safe and responsible with the use and disposal of cleaning products.

Never use acetone, gasoline, or lacquer thinner to remove stains or oil from painted surfaces. These chemicals will melt the paint. Use mineral spirits or mild household degreasers. To control surface rust on machined surfaces, wipe the unprotected metal as required with a rust inhibiting oil.



For daily lubrication, use a manual oil gun with a general 10W machine oil to lubricate the following 15 ball oiler fittings. See **Figure 51** for some typical locations.

Wipe off all oil ball fittings with a rag, and then oil the following locations:

- Cross slide Table (1 ball oiler on top)
- Cross slide Handwheel (1 ball oiler on top)
- Saddle Ways (2 ball oilers on top)
- Apron Handwheel Gear Axle (1 ball oiler on apron face)
- Compound Rest (1 ball oiler on top)
- Tailstock Barrel (1 ball oiler on top)
- Tailstock Handwheel (1 ball oiler on right side)
- Lead Screw Endcap Bushing (1 ball oiler, see **Figure 51**)
- Change Gear Spindle (1 ball oiler on end of shaft)
- Gear Spindle Ball Oiler (1 ball oiler, see **Figure 48**)
- Gearbox (4 ball oilers on top)

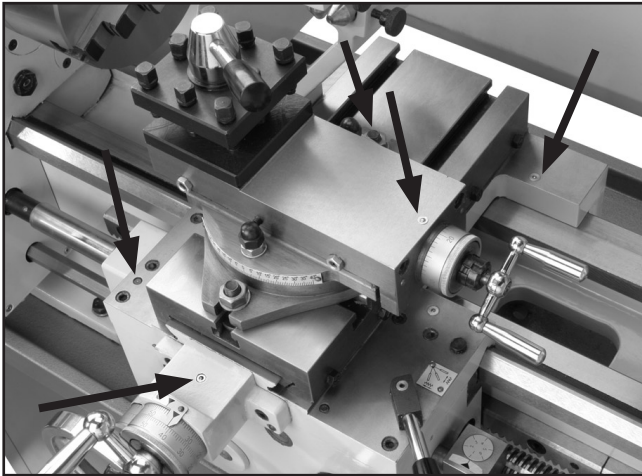

Figure 51. Typical ball fitting locations.



Figure 52. Lead screw end cap bushing.

Belt Adjustment or Replacement

To replace or adjust the V-belts:

1. DISCONNECT POWER TO THE LATHE/MILL!
2. Open the change gear access door (**Figure 53**).
3. Loosen the four motor access cover screws, and lift the cover off (**Figure 53**).
4. Using a 17mm wrench, loosen the two motor mount bolts shown in **Figure 53**.

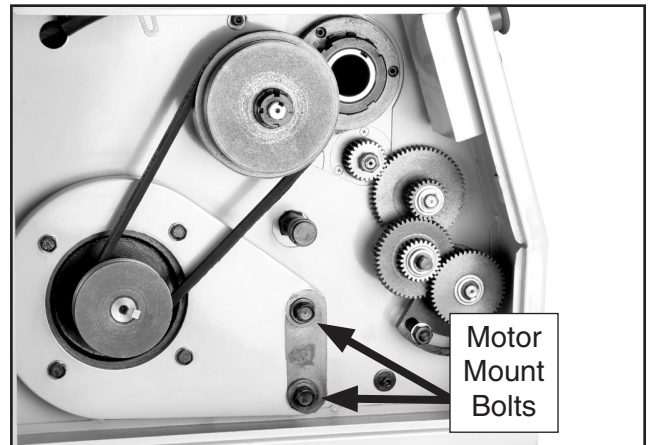

Figure 53. Motor mount bolts.

5. Grasp the motor and lift upward to de-tension the belt and remove the belt.
6. Use solvent to clean the pulleys of oil and install the new belt.
7. Let the motor hang to tension the belt, and tighten the two motor mount bolts.
8. Close the access door and latch it shut.



SECTION 7: SERVICE

Cross Slide Backlash Adjustment

Backlash is the amount of play found in a lead screw. It can be found by turning the cross slide handwheel in one direction, and then turning the handwheel the other direction. When the cross slide begins to move, the backlash has been taken up.

Note: Avoid the temptation to overtighten the cross slide backlash screw. Overtightening will cause excessive wear to the sliding block and lead screw.

Backlash is adjusted by tightening or loosening the screw shown in **Figure 54**.

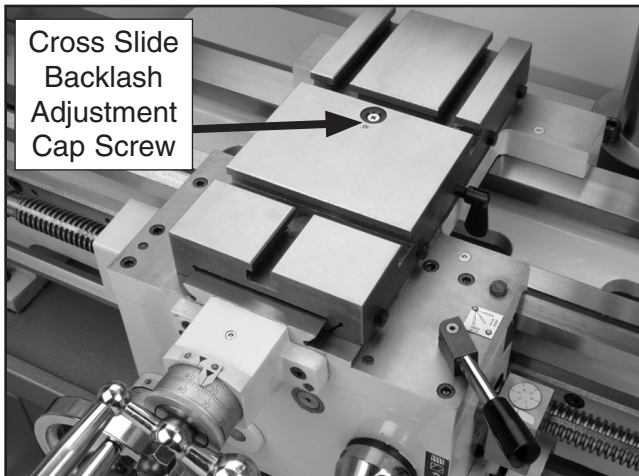

Figure 54. Cross slide backlash adjustment cap screw.

This screw draws a wedge-type nut against the lead screw and main nut. If you get it too tight, loosen the screw a few turns and tap the cross slide a few times with a rubber or wooden mallet. Then turn the handle slowly back and fourth until the handle turns freely. To readjust the backlash, rock the handle back and fourth and tighten the screw slowly until the backlash is at approximately 0.001" to 0.002" as indicated on the handwheel.

Note: Reducing backlash to less than 0.001" is impractical and reduces the life of the cross slide.

Gib Adjustments

When adjusting gibs (**Figures 55 and 56**), keep in mind that the goal is to remove sloppiness in the ways without causing the slides or half nut to bind. Loose gibs will cause a poor finish on the workpiece and wear the slide. Over-tightening will damage the slide, lead screw, and half-nut. The cross slide gib is a tapered piece of iron. When the opposing front and rear gib adjustment screws are turned in opposing directions, the screws force the tapered gibs to fill the void in the way, thus tightening the play in the cross slide. If more play is needed turn the screws the other direction.

For the four saddle gibs, (**Figure 55**) loosen the jam nuts and turn the three set screws until slight tension felt and the gib plates are slightly pre-loaded against the underside of the flat-way. Tighten the jam nuts when finished.

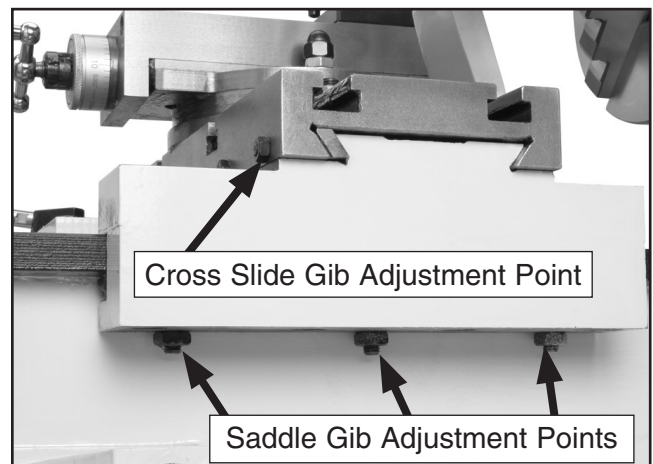

Figure 55. Gib adjustment points.

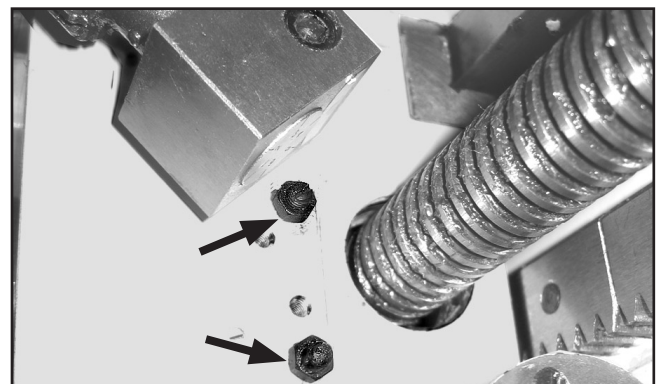
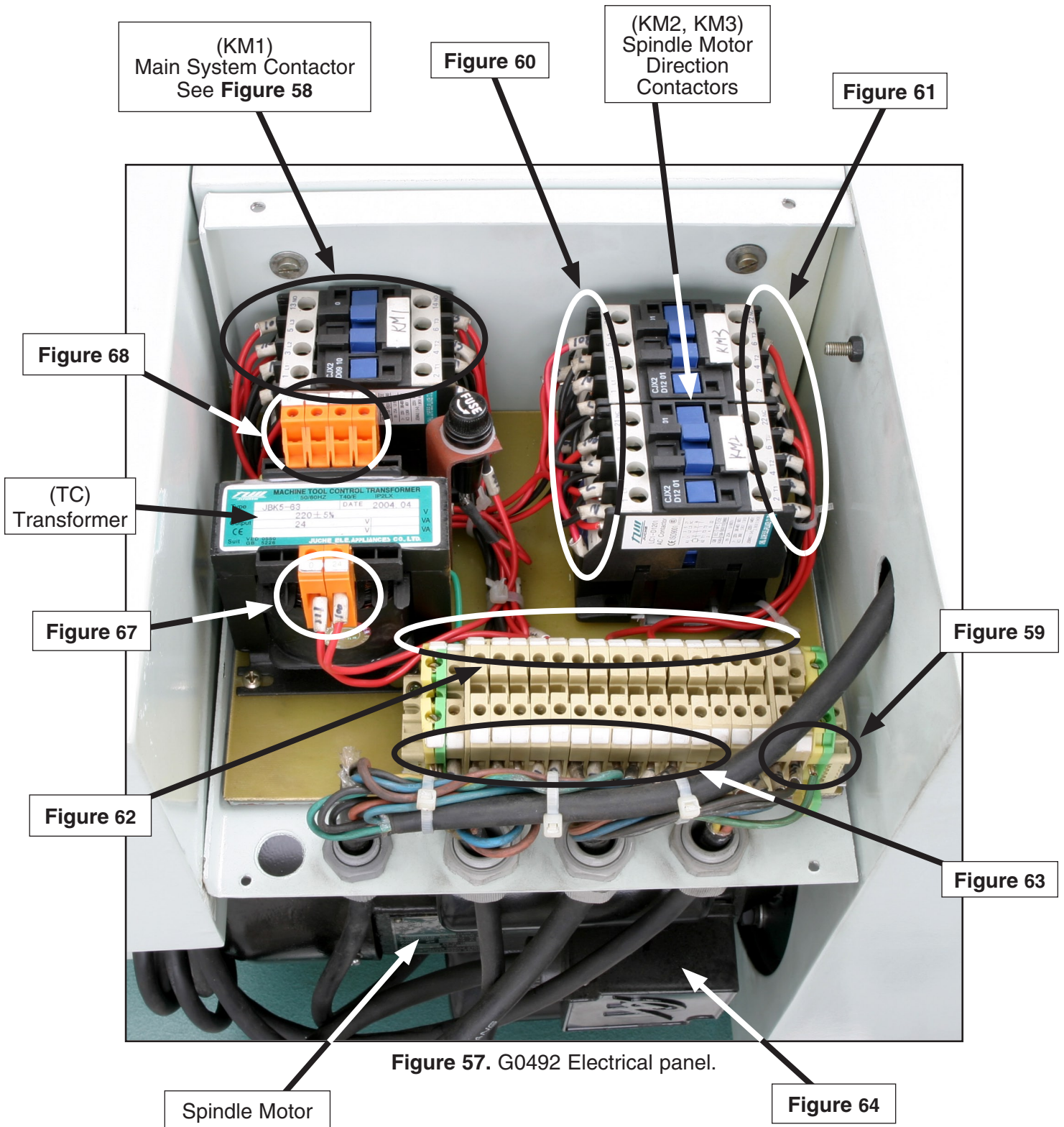

Figure 56. Half-nut gib adjustment location.



Electrical Component and Connection Index



Electrical Connections

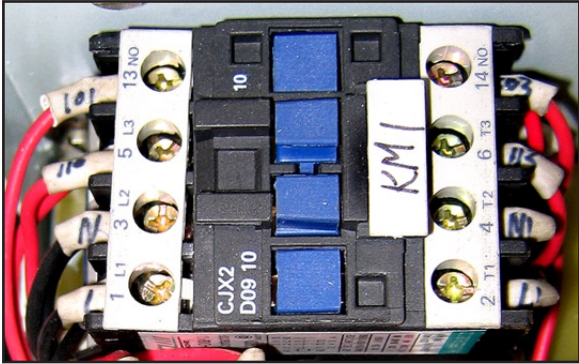

Figure 58. Contactor wiring (KM1).

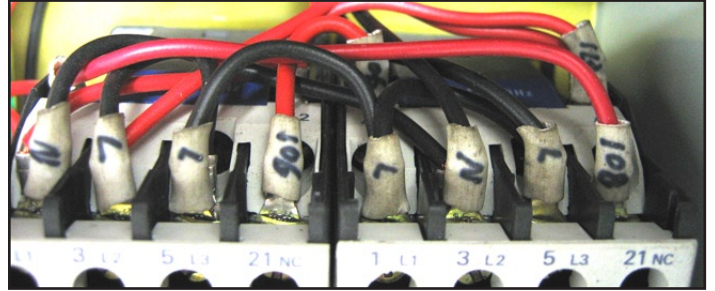

Figure 60. Contactor wiring (KM2 and KM3).

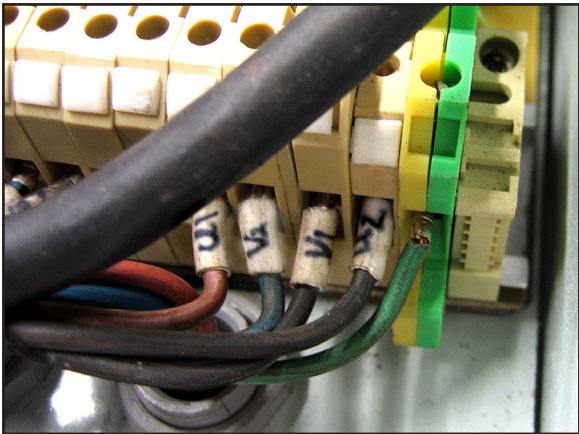

Figure 59. Junction block wiring.

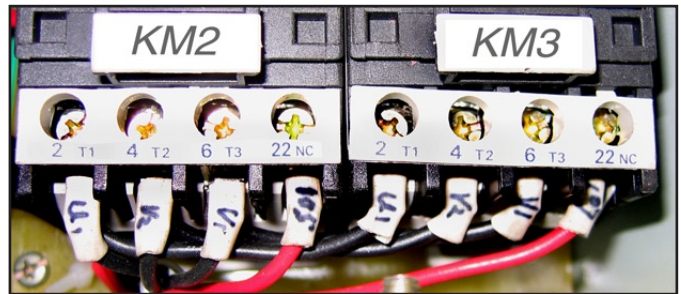

Figure 61. Contactor wiring (KM2 and KM3).

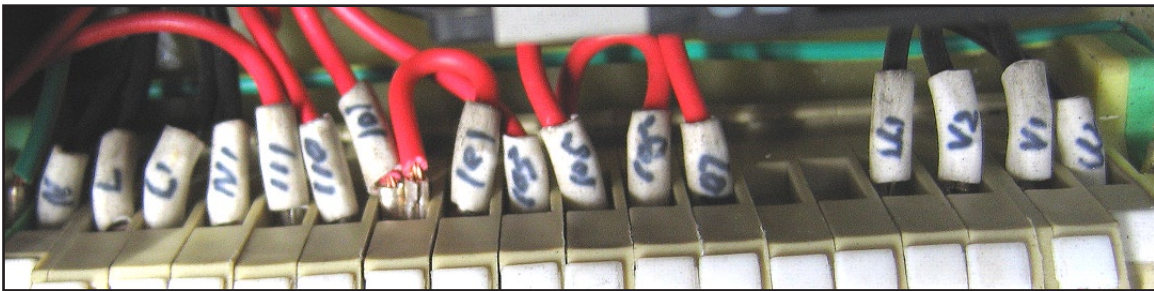

Figure 62. Junction block wiring.



Figure 63. Junction block wiring.



Electrical Connections

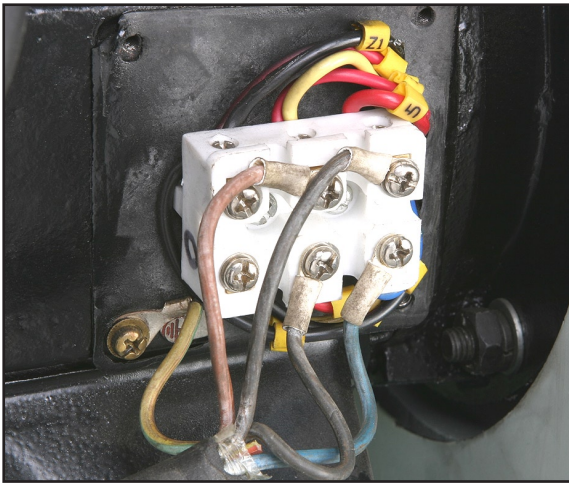

Figure 64. Motor connection.

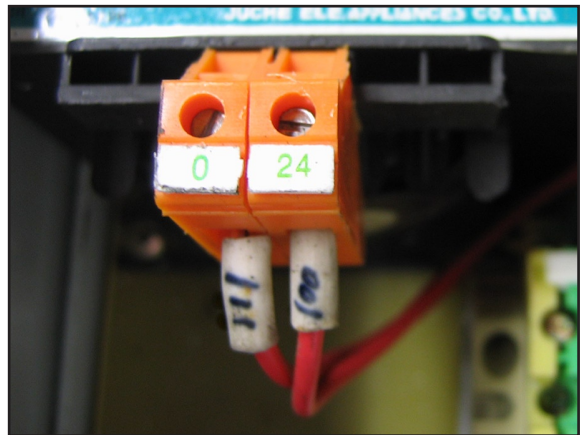

Figure 67. Transformer output connection.

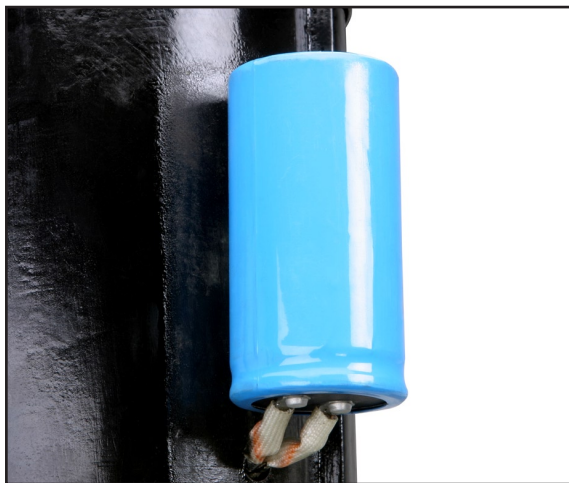

Figure 65. Start capacitor.

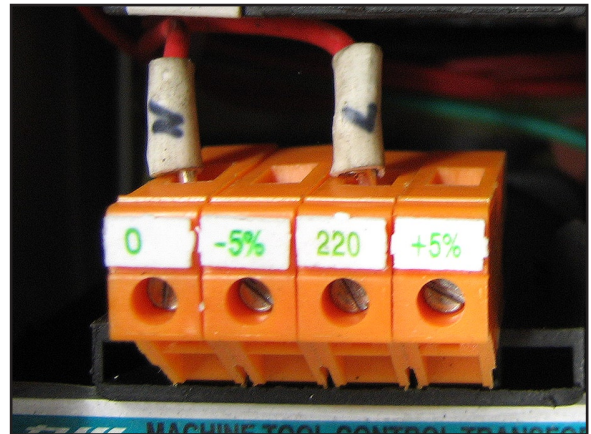

Figure 68. Transformer input connection.



Figure 66. Mill power switch.

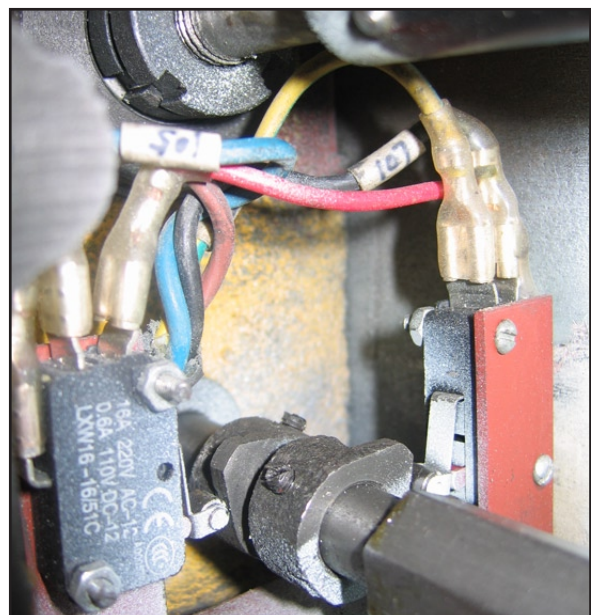

Figure 69. Lathe motor direction limit switches.



Electrical Connections

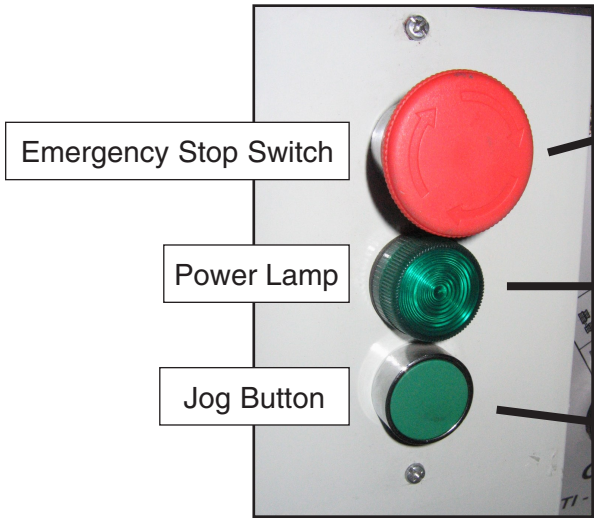

Figure 70. Lathe controls.

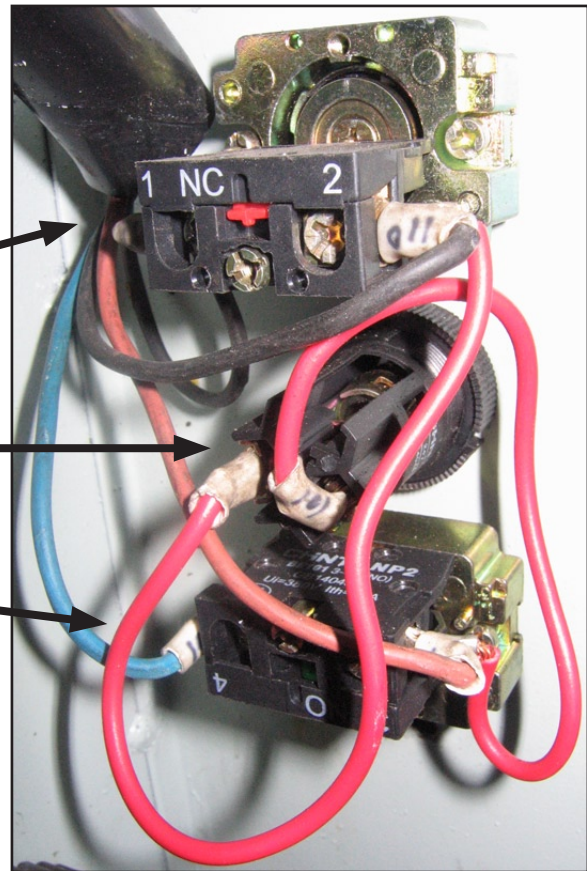
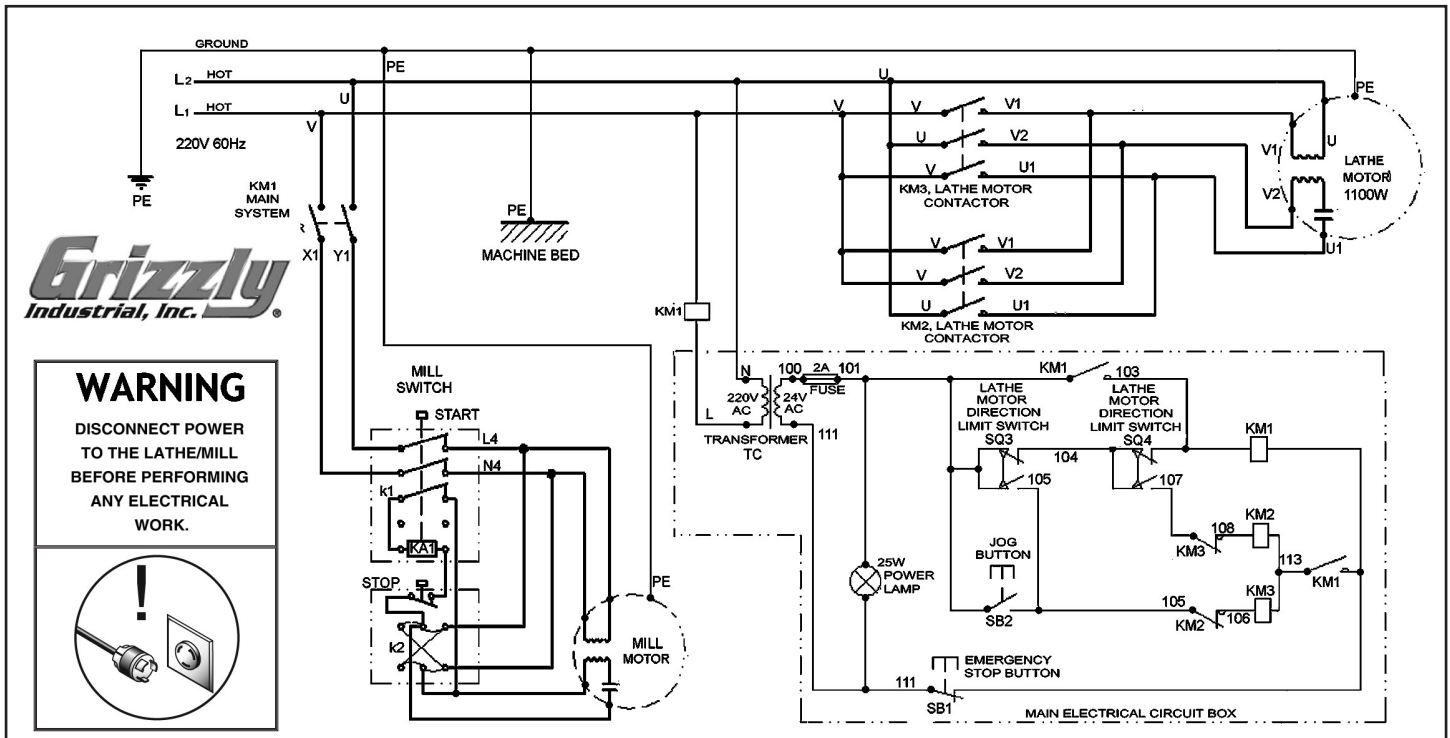
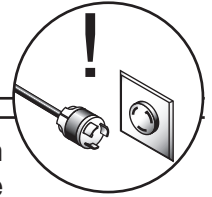

Figure 71. Lathe control panel wiring.

220V Wiring Diagram



Troubleshooting



Review the troubleshooting and procedures in this section to fix your machine if a problem develops. If you need replacement parts or you are unsure of your repair skills, then feel free to call our Technical Support at (570) 546-9663.

Motor & Electrical

Symptom	Possible Cause	Possible Solution
Motor will not start.	<ol style="list-style-type: none"> 1. Incorrect lathe operation. 2. Main power panel switch is OFF. 3. Emergency switch is pushed in. 4. Circuit breaker or fuse has tripped. 5. No voltage or open connection. 6. Capacitor is at fault. 7. Limit switch is at fault. 8. Power switch or magnetic contactor is at fault. 9. Transformer or fuse at fault 10. Motor is at fault. 	<ol style="list-style-type: none"> 1. Use the spindle direction ON/OFF lever. 2. Turn the main power panel switch ON. 3. Rotate emergency switch so it pops out. 4. Seek an electrician to troubleshoot and repair the shop power supply. 5. Test circuit, replace wires and connections as required. 6. Replace capacitor. 7. Replace limit switch. 8. Replace power switch or magnetic contactor. 9. Replace transformer or fuse. 10. Replace motor.
Fuses or circuit breakers trip open.	<ol style="list-style-type: none"> 1. Short circuit in line cord or plug. 2. Short circuit in motor or loose connections. 3. Incorrect fuses or circuit breakers in power supply. 	<ol style="list-style-type: none"> 1. Inspect cord or plug for damaged insulation and shorted wires. 2. Inspect all connections on motor for loose or shorted terminals or worn insulation. 3. Install correct fuses or circuit breakers.
Carriage hard to move.	<ol style="list-style-type: none"> 1. Chips have loaded up on bedways. 2. Bedways are dry and in need of lubrication. 3. Longitudinal stops are interfering. 4. Gibs are too tight. 	<ol style="list-style-type: none"> 1. Frequently clean away chips that load up during turning operations. 2. Lubricate bedways and handles. 3. Check to make sure that stops are floating and not hitting the center stop. 4. Loosen gib screw(s) slightly.
Machine is loud when cutting. Overheats or bogs down in the cut.	<ol style="list-style-type: none"> 1. Excessive depth of cut. 2. RPM or feed rate wrong for operation. 3. Dull cutters. 	<ol style="list-style-type: none"> 1. Decrease depth of cut. 2. Refer to RPM feed rate chart for appropriate rates. 3. Sharpen or replace cutters.
Bad surface finish.	<ol style="list-style-type: none"> 1. Wrong RPM or feed rate. 2. Dull tooling or tool not centered correctly. 3. Too much play in gibs. 	<ol style="list-style-type: none"> 1. Adjust for appropriate RPM and feed rate. 2. Sharpen tooling and/or center tool correctly. 3. Tighten gibs.
Gear change levers will not shift into position.	<ol style="list-style-type: none"> 1. Gears not aligned in headstock. 	<ol style="list-style-type: none"> 1. Rotate spindle by hand until gear falls into place.



Troubleshooting

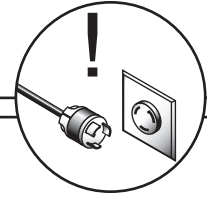

Operation and Work Results

Symptom	Possible Cause	Possible Solution
Entire machine vibrates excessively upon startup and while running.	<ol style="list-style-type: none"> 1. Workpiece is unbalanced. 2. Worn or broken gear present. 3. Chuck or faceplate has become unbalanced. 4. Spindle bearings badly worn. 	<ol style="list-style-type: none"> 1. Reinstall workpiece so it is as centered with the spindle bore as possible. 2. Inspect gears and replace if necessary. 3. Rebalance chuck or faceplate; contact a local machine shop for help. 4. Replace spindle bearings.
Cutting tool or machine components vibrate excessively during cutting.	<ol style="list-style-type: none"> 1. Tool holder not tight enough. 2. Cutting tool sticks too far out of tool holder; lack of support. 3. Gibs are out of adjustment. 4. Dull cutting tool. 5. Incorrect spindle speed or feed rate. 	<ol style="list-style-type: none"> 1. Check for debris, clean, and retighten. 2. Reinstall cutting tool so no more than 1/3 of the total length is sticking out of tool holder. 3. Tighten gib screws at affected component. 4. Replace or re sharpen cutting tool. 5. Use the recommended spindle speed.
Can't remove tapered tool from tailstock quill.	<ol style="list-style-type: none"> 1. Quill had not retracted all the way back into the tailstock. 2. Debris was not removed from taper before inserting into quill. 	<ol style="list-style-type: none"> 1. Turn the quill handwheel until it forces taper out of quill. 2. Always make sure that taper surfaces are clean.
Cross slide, compound rest, or carriage feed has sloppy operation.	<ol style="list-style-type: none"> 1. Gibs are out of adjustment. 2. Handwheel is loose. 3. Lead screw mechanism worn or out of adjustment. 	<ol style="list-style-type: none"> 1. Tighten gib screw(s). 2. Tighten handwheel fasteners. 3. Tighten any loose fasteners on lead screw mechanism.
Cross slide, compound rest, or carriage feed handwheel is hard to move.	<ol style="list-style-type: none"> 1. Gibs are loaded up with shavings, dust, or grime. 2. Gib screws are too tight. 3. Backlash setting too tight (cross slide only). 4. Bedways are dry. 	<ol style="list-style-type: none"> 1. Remove gibs, clean ways/dovetails, lubricate, and readjust gibs. 2. Loosen gib screw(s) slightly, and lubricate bedways. 3. Slightly loosen backlash setting by loosening the locking screw and adjusting the spanner ring at the end of the handle. 4. Lubricate bedways and handles.
Bad surface finish.	<ol style="list-style-type: none"> 1. Wrong RPM or feed rate. 2. Dull tooling or poor tool selection. 3. Too much play in gibs. 4. Tool too high. 	<ol style="list-style-type: none"> 1. Adjust for appropriate RPM and feed rate. 2. Sharpen tooling or select a better tool for the intended operation. 3. Tighten gibs. 4. Lower the tool position.
Inaccurate turning results from one end of the workpiece to the other.	<ol style="list-style-type: none"> 1. Headstock and tailstock are not properly aligned with each other. 	<ol style="list-style-type: none"> 1. Realign the tailstock to the headstock spindle bore center line.
Chuck jaws won't move or don't move easily.	<ol style="list-style-type: none"> 1. Chips lodged in the jaws. 	<ol style="list-style-type: none"> 1. Remove jaws, clean and lubricate chuck threads, and replace jaws.
Carriage won't feed.	<ol style="list-style-type: none"> 1. Gears are not all engaged. 2. Gears are broken. 3. Loose screw on the feed handle. 	<ol style="list-style-type: none"> 1. Adjust gear positions. 2. Replace. 3. Tighten.



Troubleshooting

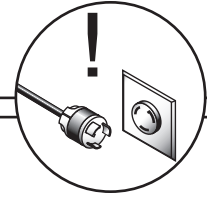

Operation and Work Results (Continued)

Symptom	Possible Cause	Possible Solution
Loud, repetitious noise coming from machine at or near the motor.	<ol style="list-style-type: none"> 1. Pulley setscrews or keys are missing or loose. 2. Motor fan is hitting the cover. 	<ol style="list-style-type: none"> 1. Inspect keys and setscrews. Replace or tighten if necessary. 2. Tighten fan or shim cover, or replace items.
Motor is loud when cutting. Overheats or bogs down in the cut.	<ol style="list-style-type: none"> 1. Excessive depth of cut or feed rate. 2. RPM or feed rate wrong for cutting operation. 3. Cutting tool is dull. 4. Gear setup is too tight, causing them to bind. 	<ol style="list-style-type: none"> 1. Decrease depth of cut or feed rate. 2. Refer to RPM feed rate chart for appropriate rates. 3. Sharpen or replace the cutting tool. 4. Readjust the gear setup with a small amount of backlash so the gears move freely and smoothly when the chuck is rotated by hand.
Loud, repetitious noise coming from machine.	<ol style="list-style-type: none"> 1. Gears not aligned in headstock or no backlash. 2. Broken gear or bad bearing. 3. Workpiece is hitting stationary object. 	<ol style="list-style-type: none"> 1. Adjust gears and establish backlash. 2. Replace broken gear or bearing. 3. Stop lathe immediately and correct interference problem.
Motor overheats.	<ol style="list-style-type: none"> 1. Motor overloaded. 2. Air circulation through the motor restricted. 	<ol style="list-style-type: none"> 1. Reduce load on motor. 2. Clean out motor to provide normal air circulation.
Gear change levers will not shift into position.	<ol style="list-style-type: none"> 1. Gears not aligned in headstock. 	<ol style="list-style-type: none"> 1. Rotate spindle by hand until gear falls into place.
Tailstock quill will not feed out of tailstock.	<ol style="list-style-type: none"> 1. Quill lock lever is tightened down. 	<ol style="list-style-type: none"> 1. Turn lever counterclockwise.
Carriage hard to move.	<ol style="list-style-type: none"> 1. Carriage lock is tightened down. 2. Chips have loaded up on bedways. 3. Bedways are dry and in need of lubrication. 4. Longitudinal stops are interfering. 5. Gibs are too tight. 	<ol style="list-style-type: none"> 1. Check to make sure table locks are fully released. 2. Frequently clean away chips that load up during turning operations. 3. Lubricate bedways and handles. 4. Check to make sure that stops are floating and not hitting the center stop. 5. Loosen gib screw(s) slightly.



SECTION 8: ACCESSORIES

H2689—R8 Quick Change Collet Set

An affordable quick change collet system with ultra precision. These spring collets are hardened and ground to exacting tolerances and offer incredible holding power. This set includes an R8 arbor and nut, spanner wrench, plastic carrying case and collets sized $\frac{1}{8}$ ", $\frac{1}{4}$ ", $\frac{3}{8}$ ", $\frac{1}{2}$ ", $\frac{5}{8}$ ", $\frac{3}{4}$ ", $\frac{7}{8}$ ", and 1". What's more, the nut features a self-ejecting rim! A set like this will truly speed up any tool changing process. Drawbar size is $\frac{7}{16}$ " x 20.

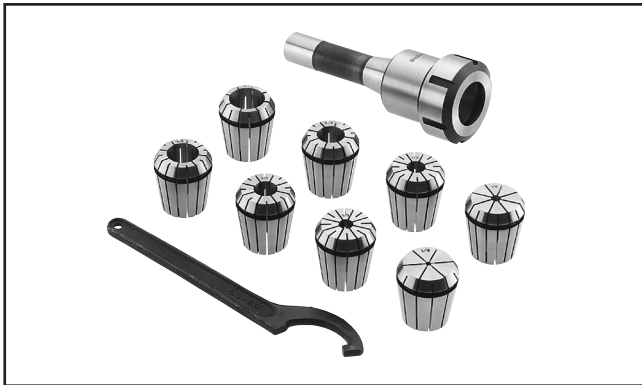

Figure 72. H2689 R8 Quick Change Collet Set.

G9760—20-PC. 2 & 4 Flute TiN End Mill Set.

Includes these sizes and styles in two and four flute styles: $\frac{3}{16}$ ", $\frac{1}{4}$ ", $\frac{5}{16}$ ", $\frac{3}{8}$ ", $\frac{7}{16}$ ", $\frac{1}{2}$ ", $\frac{9}{16}$ ", $\frac{5}{8}$ ", $\frac{3}{8}$ ", $\frac{11}{16}$ ", and $\frac{3}{4}$ ".



Figure 73. G9760 20-PC End Mill Set.

H4959—Coolant Dispenser

Delivers a small amount of lubricant to the cutting surface to improve tool life and cutting efficiency. An absolute must for heavy lathe and milling operations.



Figure 74. H4959 Coolant Dispenser.

G5562—SLIPIT® 1 Qt. Gel

G5563—SLIPIT® 12 oz Spray

G2871—Boeshield® T-9 12 oz Spray

G2870—Boeshield® T-9 4 oz Spray

H3788—G96® Gun Treatment 12 oz Spray

H3789—G96® Gun Treatment 4.5 oz Spray



Figure 75. Recommended products for protecting unpainted cast iron/steel areas.

Call 1-800-523-4777 To Order



SECTION 9: PARTS

Electrical Box (0000 Series Parts)

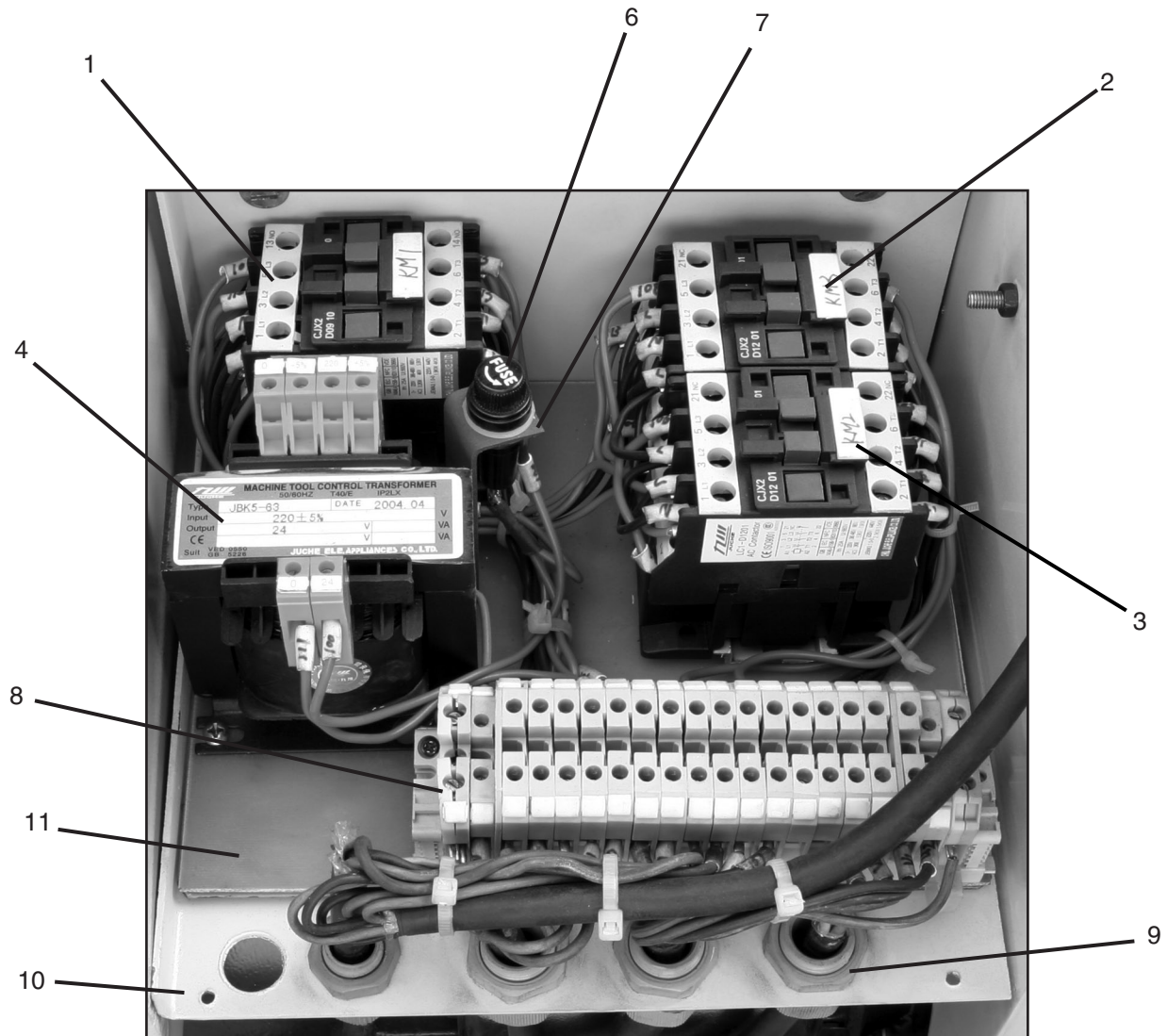

0000 Series Parts List

REF	PART #	DESCRIPTION
1	P04920001	CONTACTOR (LC1-D0910, B5, 24V, 50HZ)
2	P04920002	CONTACTOR (LC1-D1201, B5, 24V, 50HZ)
3	P04920003	CONTACTOR (LC1-D1201, B5, 24V, 50HZ)
4	P04920004	TRANSFORMER (JBK5-63), (INPUT 220V +/- 5%, OUTPUT 24V)

REF	PART #	DESCRIPTION
6	P04920006	FUSE 2A
7	P04920007	FUSE HOUSING
8	P04920008	TERMINAL BLOCK
9	P04920009	STRAIN RELIEF
10	P04920010	ELECTRICAL BOX
10-1	P04920010-1	ELECTRICAL BOX COVER
11	P04920011	CONTACTOR MOUNTING PLATE



Lathe Change Gear Housing Diagram (1000 Series Parts)

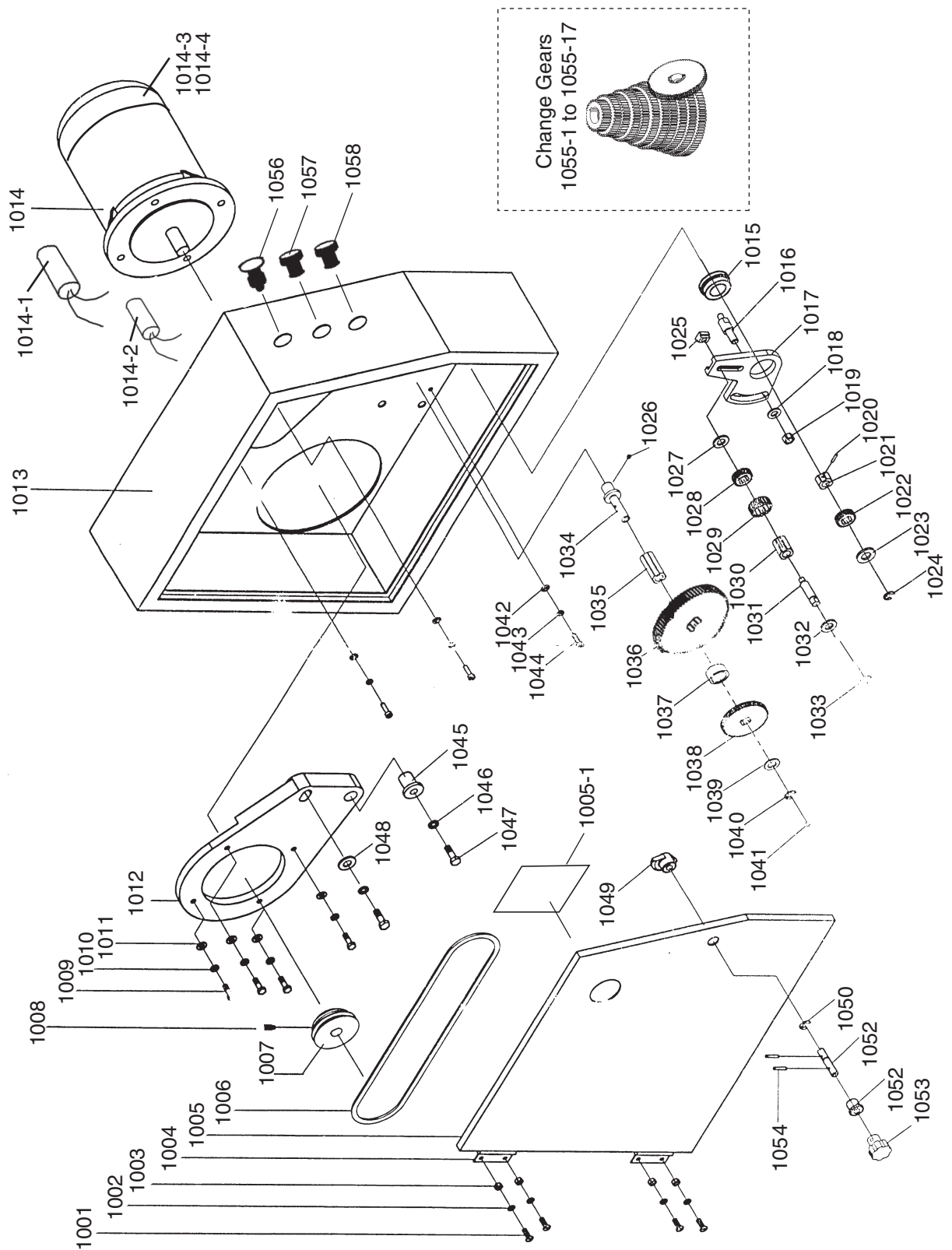

1000 Series Parts List

REF	PART #	DESCRIPTION
1001	PS38M	PHLP HD SCR M4-.7 X 10
1002	PLW02M	LOCK WASHER 4MM
1003	PN04M	HEX NUT M4-.7
1004	P04921004	HINGE
1005	P04921005	DOOR
1005-1	P04921005-1	CHANGE GEAR CHART
1006	PVA71	V-BELT A-71 4L710
1007	P04921007	MOTOR PULLEY
1008	PSS03M	SET SCREW M6-1 X 8
1009	PB07M	HEX BOLT M8-1.25 X 25
1010	PLW04M	LOCK WASHER 8MM
1011	PW01M	FLAT WASHER 8MM
1012	P04921012	MOTOR MOUNT PLATE
1013	P04921013	COMPOUND BOX
1014	P04921014	MOTOR 3/4HP 220V
1014-1	P04921014-1	RUN CAPACITOR 20MFD/450VAC
1014-2	P04921014-2	S. CAPACITOR 150MFD/250VAC
1014-3	P04921014-3	MOTOR FAN
1014-4	P04921014-4	FAN COVER
1015	P04921015	SLEEVE
1016	P04921016	SHAFT
1017	P04921017	LASH ADJUSTER
1018	PW04M	FLAT WASHER 10MM
1019	PN02M	HEX NUT M10-1.5
1020	PRP64M	ROLL PIN 3 X 18MM
1021	P04921021	SPLINED WEAR BUSHING (13MM LONG)
1022	P04921022	CHANGE GEAR (48-TOOTH)
1023	PW06M	FLAT WASHER 12MM
1024	PEC12M	E-CLIP 12MM
1025	P04921025	T-NUT
1026	P04921026	SPECIAL SCREW
1027	PW06M	FLAT WASHER 12MM
1028	P04921028	CHANGE GEAR (50-TOOTH)
1029	P04921029	CHANGE GEAR (25-TOOTH)
1030	P04921030	SPLINED WEAR BUSHING (26MM LONG)
1031	P04921031	IDLER SHAFT
1032	PW06M	FLAT WASHER 12MM
1033	PEC12M	E-CLIP 12MM
1034	P04921034	IDLER SHAFT

REF	PART #	DESCRIPTION
1035	P04921035	LONG SPLINED WEAR BUSHING
1036	P04921036	CHANGE GEAR (60-TOOTH)
1037	P04921037	SPACER SLEEVE
1038	P04921038	CHANGE GEAR (24-TOOTH)
1039	PW06M	FLAT WASHER 12MM
1040	PEC12M	E-CLIP 12MM
1041	P04921041	BALL OILER 6MM
1042	PW03M	FLAT WASHER 6MM
1043	PLW03M	LOCK WASHER 6MM
1044	PSB01M	CAP SCREW M6-1 X 16
1045	P04921045	SHOULDER BUSHING
1046	PLW06M	LOCK WASHER 10MM
1047	PB116M	HEX BOLT M10-1.5 X 45
1048	PW04M	FLAT WASHER 10MM
1049	P04921049	DOOR LATCH
1050	PEC09M	E-CLIP 6MM
1051	P04921051	TUMBLER SHAFT
1052	P04921052	SHOULDER SLEEVE
1053	P04921053	STAR-GRIP KNOB #8-32
1054	P04921054	TAPER PINS
1055-1	P04921055-1	CHANGE GEAR (24-TOOTH)
1055-2	P04921055-2	CHANGE GEAR (25-TOOTH)
1055-3	P04921055-3	CHANGE GEAR (27-TOOTH)
1055-4	P04921055-4	CHANGE GEAR (28-TOOTH)
1055-5	P04921055-5	CHANGE GEAR (30-TOOTH)
1055-6	P04921055-6	CHANGE GEAR (32-TOOTH)
1055-7	P04921055-7	CHANGE GEAR (34-TOOTH)
1055-8	P04921055-8	CHANGE GEAR (35-TOOTH)
1055-9	P04921055-9	CHANGE GEAR (36-TOOTH)
1055-10	P04921055-10	CHANGE GEAR (40-TOOTH)
1055-11	P04921055-11	CHANGE GEAR (42-TOOTH)
1055-12	P04921055-12	CHANGE GEAR (44-TOOTH)
1055-13	P04921055-13	CHANGE GEAR (46-TOOTH)
1055-14	P04921055-14	CHANGE GEAR (48-TOOTH)
1055-15	P04921055-15	CHANGE GEAR (50-TOOTH)
1055-16	P04921055-16	CHANGE GEAR (52-TOOTH)
1055-17	P04921055-17	CHANGE GEAR (60-TOOTH)
1056	P04921056	EMERGENCY STOP SWITCH
1057	P04921057	GREEN POWER LAMP
1058	P04921058	JOG BUTTON



Leadscrew Gearbox Diagram (2700 Series Parts)

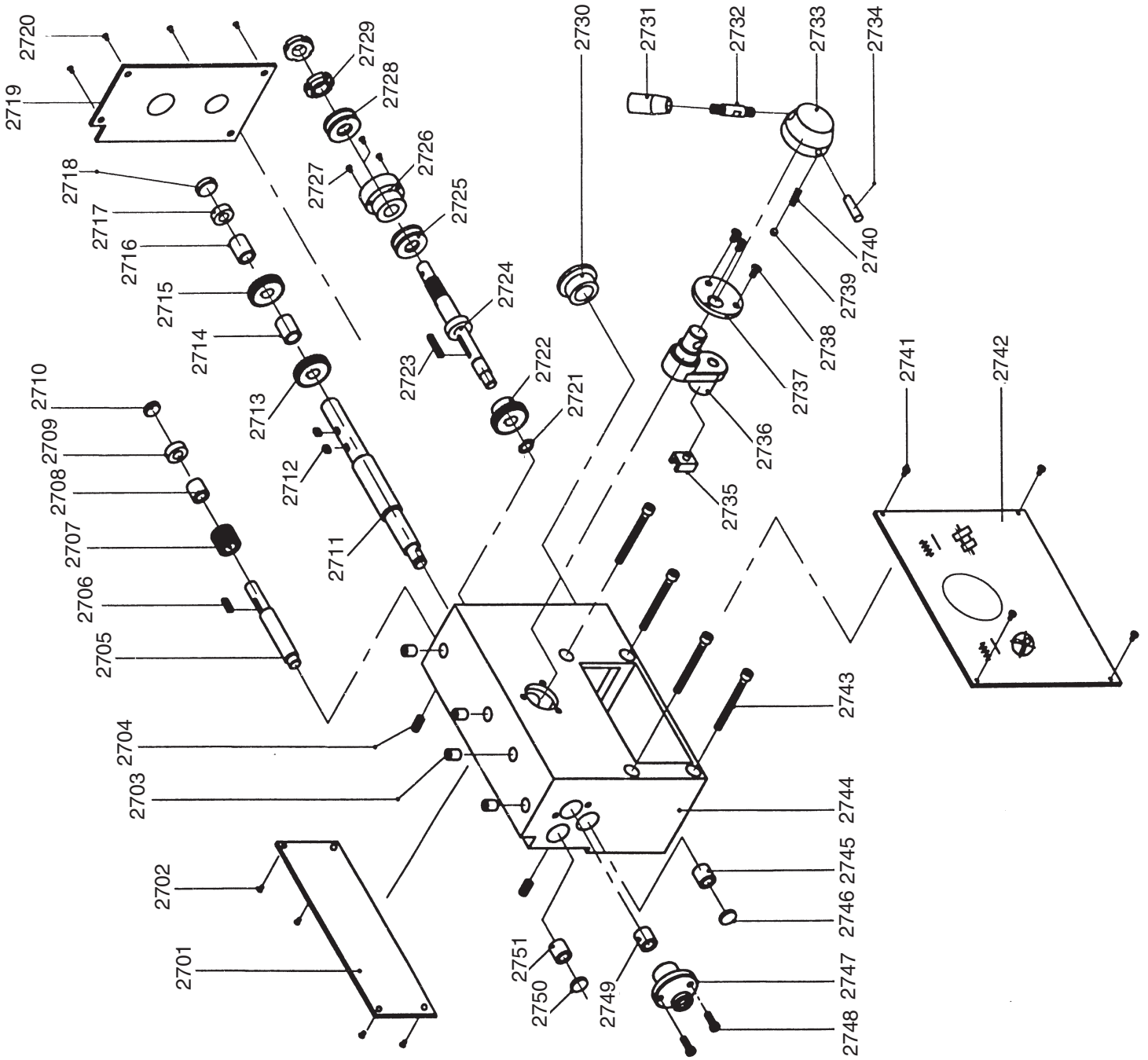

2700 Series Parts List

REF	PART #	DESCRIPTION
2701	P04922701	COVER PLATE
2702	PS05M	PHLP HD SCR M5-.8 X 8
2703	P04922703	BALL OILER 8MM
2704	P04922704	SPECIAL SET SCREW M5-.8 X 6
2705	P04922705	SHAFT
2706	PK08M	KEY 5 X 5 X 16
2707	P04922707	GEAR (20-TOOTH)
2708	P04922708	SPACER
2709	P04922709	SLEEVE
2710	P04922710	PLUG
2711	P04922711	SHAFT
2712	PK127M	KEY 5 X 5 X 8
2713	P04922713	GEAR (20-TOOTH)
2714	P04922714	SPACER
2715	P04922715	GEAR (20-TOOTH)
2716	P04922716	SPACER
2717	P04922717	SLEEVE
2718	P04922718	PLUG
2719	P04922719	COVER PLATE
2720	PS07M	PHLP HD SCR M4-.7 X 8
2721	PR06M	EXT RETAINING RING 16MM
2722	P04922722	GEAR (20-TOOTH)
2723	PK126M	KEY 5 X 5 X 32
2724	P04922724	SHAFT
2725	P8102	BEARING 8102
2726	P04922726	FLANGE HUB

REF	PART #	DESCRIPTION
2727	PSB24M	CAP SCREW M5-.8 X 16
2728	P8102	BEARING 8102
2729	P04922729	SPANNER NUT
2730	P04922730	FLANGE HUB
2731	P04922731	KNOB M8-1.25 FEMALE
2732	P04922732	LEVER
2733	P04922733	LEVER HUB
2734	P04922734	TAPER PIN
2735	P04922735	SHIFTING YOKE
2736	P04922736	SHIFTING FORK
2737	P04922737	LOCATING PLATE
2738	PFH07M	FLAT HD SCR M5-.8 X 10
2739	P04923077	STEEL BALL 6.5MM
2740	P04922740	COMPRESSION SPRING
2741	PS12M	PHLP HD SCR M3-.5 X 6
2742	P04922742	FRONT PANEL
2743	P04922743	CAP SCREW M8-1.25 X 100
2744	P04922744	HOUSING
2745	P04922745	BUSHING
2746	P04922746	PLUG
2747	P04922747	FLANGE HUB
2748	PSB33M	CAP SCREW M5-.8 X 12
2749	P04922749	BUSHING
2750	P04922750	PLUG
2751	P04922751	BUSHING



Thread Dial Diagram (3000 Series Parts)

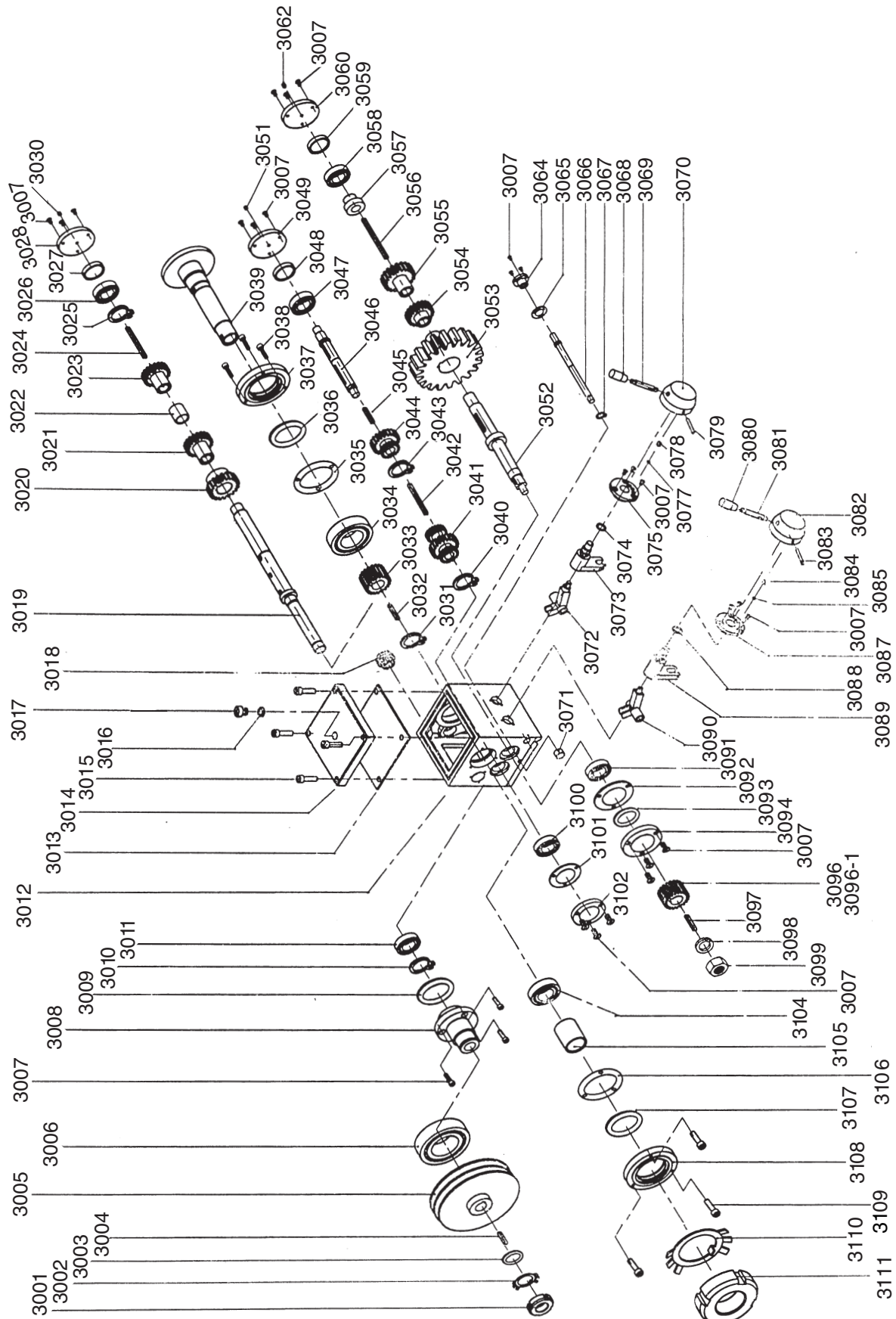

3000 Series Parts List

REF	PART #	DESCRIPTION
3001	P04923001	SPANNER NUT M16-1.5
3002	P04923002	TANG WASHER
3003	PW08M	FLAT WASHER 16MM
3004	PK08M	KEY 5 X 5 X 16
3005	P04923005	SPINDLE PULLEY
3006	P04923006	TAPER ROLLER BEARING 60206
3007	PSB33M	CAP SCREW M5-.8 X 12
3008	P04923008	HUB
3009	P04923009	FELT SEAL
3010	PR06M	EXT RETAINING RING 16MM
3011	P04923011	BALL BEARING 203
3012	P04923012	HEADSTOCK CASTING
3013	P04923013	GASKET
3014	P04923014	HEADSTOCK COVER
3015	PSB13M	CAP SCREW M8-1.25 X 30
3016	P04923016	O-RING 30 X 20 X 2MM
3017	P04923017	FILL PLUG
3018	P04923018	SIGHT GLASS
3019	P04923019	SPINDLE SHAFT
3020	P04923020	GEAR (42-TOOTH)
3021	P04923021	GEAR (20-TOOTH)
3022	P04923022	SLEEVE SPACER
3023	P04923023	GEAR (30-TOOTH)
3024	PK13M	KEY 5 X 5 X 70
3025	PR07M	EXT RETAINING RING 18MM
3026	P04923011	BALL BEARING 203
3027	P04923027	BEARING SLEEVE
3028	P04923028	END CAP
3030	PSS03M	SET SCREW M6-1 X 8
3031	PR78M	EXT RETAINING RING 55MM
3032	P04923032	THIN FLAT KEY
3033	P04923033	GEAR (56-TOOTH)
3034	P04923034	TAPER ROLLER BEARING D2007112
3035	P04923035	SPANNER WASHER 120MM
3036	P04923036	FELT RING
3037	P04923037	MAINSHAFT OIL SEAL
3038	PB42M	HEX BOLT M5-.8 X 20
3039	P04923039	LATHE SPINDLE
3040	PR09M	EXT RETAINING RING 20MM
3041	P04923041	CLUSTER GEAR
3042	PK128M	KEY 5 X 5 X 60
3043	PR09M	EXT RETAINING RING 20MM
3044	P04923044	COMBO GEAR (22/57-TOOTH)
3045	PK02M	KEY 5 X 5 X 40
3046	P04923046	INTERMEDIATE SHAFT
3047	P04923011	BALL BEARING 203
3048	P04923048	SLEEVE
3049	P04923049	END CAP
3051	PSS03M	SET SCREW M6-1 X 8
3052	P04923052	OUTPUT SHAFT
3053	P04923053	HUGE GEAR (68-TOOTH)
3054	P04923054	GEAR (33-TOOTH)
3055	P04923055	GEAR (56-TOOTH)

REF	PART #	DESCRIPTION
3056	PK128M	KEY 5 X 5 X 60
3057	P04923057	SPACER SLEEVE
3058	P04923011	BALL BEARING 203
3059	P04923059	SLEEVE
3060	P04923060	END CAP
3062	PSS03M	SET SCREW M6-1 X 8
3064	P04923064	FIXED FLANGE
3065	P04923065	SPANNER WASHER 45MM
3066	P04923066	SHIFT FORK SHAFT
3067	PR03M	EXT RETAINING RING 12MM
3068	P04923068	KNOB M8-1.25 FEMALE
3069	P04923069	LEVER
3070	P04923070	LEVER HUB
3071	P04923071	OIL DRAIN
3072	P04923072	RIGHT SHIFTING FORK
3073	P04923073	RIGHT SHIFTING FORK SHAFT
3074	P04923074	O-RING
3075	P04923075	FIXED FLANGE
3077	P04923077	STEEL BALL 6.5MM
3078	P04923078	COMPRESSION SPRING
3079	P04923079	TAPER PIN
3080	P04923080	KNOB M8-1.25 FEMALE
3081	P04923081	LEVER
3082	P04923082	LEVER HUB
3083	P04923083	TAPER PIN
3084	P04923084	COMPRESSION SPRING
3085	P04923077	STEEL BALL 6.5MM
3087	P04923087	FLANGE
3088	P04923088	OIL SEAL 16 X 2.4MM
3089	P04923089	LEFT SHIFTING FORK SHAFT
3090	P04923090	LEFT SHIFTING FORK
3091	P04923011	BALL BEARING 203
3092	P04923092	SPANNER WASHER
3093	P04923093	FELT RING
3094	P04923094	FLANGE
3096	P04923096	KEYED DRIVE GEAR (24-FINE TOOTH)
3096-1	P04923096-1	KEYED DRIVE GEAR SET (28 & 35-COARSE TOOTH)
3097	PK05M	KEY 4 X 4 X 10
3098	PLW06M	LOCK WASHER 10MM
3099	PN02M	HEX NUT M10-1.5
3100	P04923011	BALL BEARING 203
3101	P04923101	SPANNER WASHER 60MM
3102	P04923102	END CAP
3104	P04923104	TAPER ROLLER BEARING 2007110
3105	P04923105	SPECIAL WASHER
3106	P04923106	SPANNER WASHER 105MM
3107	P04923107	FELT RING
3108	P04923108	END CAP
3109	P04923109	CAP SCREW
3110	P04923110	TANG WASHER
3111	P04923111	SPANNER NUT



Compound Rest and Tool Post Diagram (3500 Series Parts)

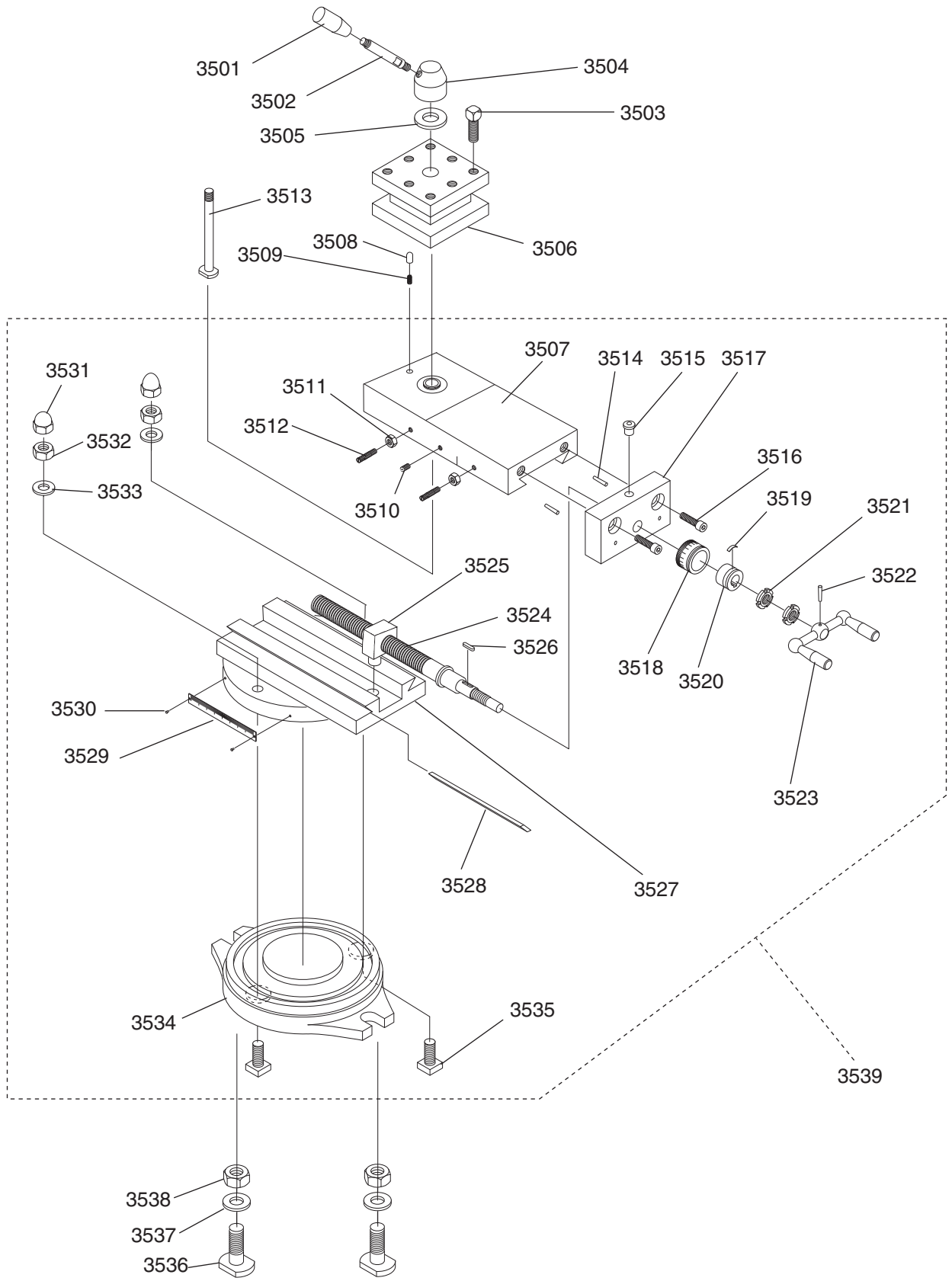

3500 Series Parts List

REF	PART #	DESCRIPTION
3501	P04923501	FEMALE KNOB 5/16-18
3502	P04923502	LEVER 5/16-20
3503	P04923503	TOOL POST BOLT M10-1.5 X 20
3504	P04923504	LEVER HUB
3505	P04923505	SPACER
3506	P04923506	FOUR-WAY TOOL POST
3507	P04923507	SLIDE
3508	P04923508	DETENT PIN
3509	P04923509	COMPRESSION SPRING
3510	PSS64M	SET SCREW M6-1 X 15
3511	PN01M	HEX NUT M6-1
3512	PSS01M	SET SCREW M6-1 X 10
3513	P04923513	T-BOLT
3514	P04923514	DOWEL PIN
3515	P04923515	BALL OILER
3516	PSB01M	CAP SCREW M6-1 X 16
3517	P04923517	END BLOCK
3518	P04923518	SCALE HUB
3519	P04923519	FLAT SPRING
3520	P04923520	HUB

REF	PART #	DESCRIPTION
3521	P04923521	SPANNER NUT
3522	P04923522	TAPERED PIN
3523	P04923523	HANDLE ASSY
3524	P04923524	LEAD SCREW
3525	P04923525	LEAD SCREW NUT
3526	P04923526	SPECIAL KEY
3527	P04923527	WAY BASE
3528	P04923528	GIB
3529	P04923529	SCALE PLATE
3530	P04923530	RIVET
3531	PN18M	ACORN NUT M8-1.25
3532	PN03M	HEX NUT M8-1.25
3533	PW01M	FLAT WASHER 8MM
3534	P04923534	BASE
3535	P04923535	T-NUT M8-1.25 X 25
3536	P04923536	T-NUT M10-1.5 X 32
3537	PW04M	FLAT WASHER 10MM
3538	PN02M	HEX NUT M10-1.5
3539	P04923539	COMPLETE COMPOUND REST



Bed Diagram (4000 Series Parts)

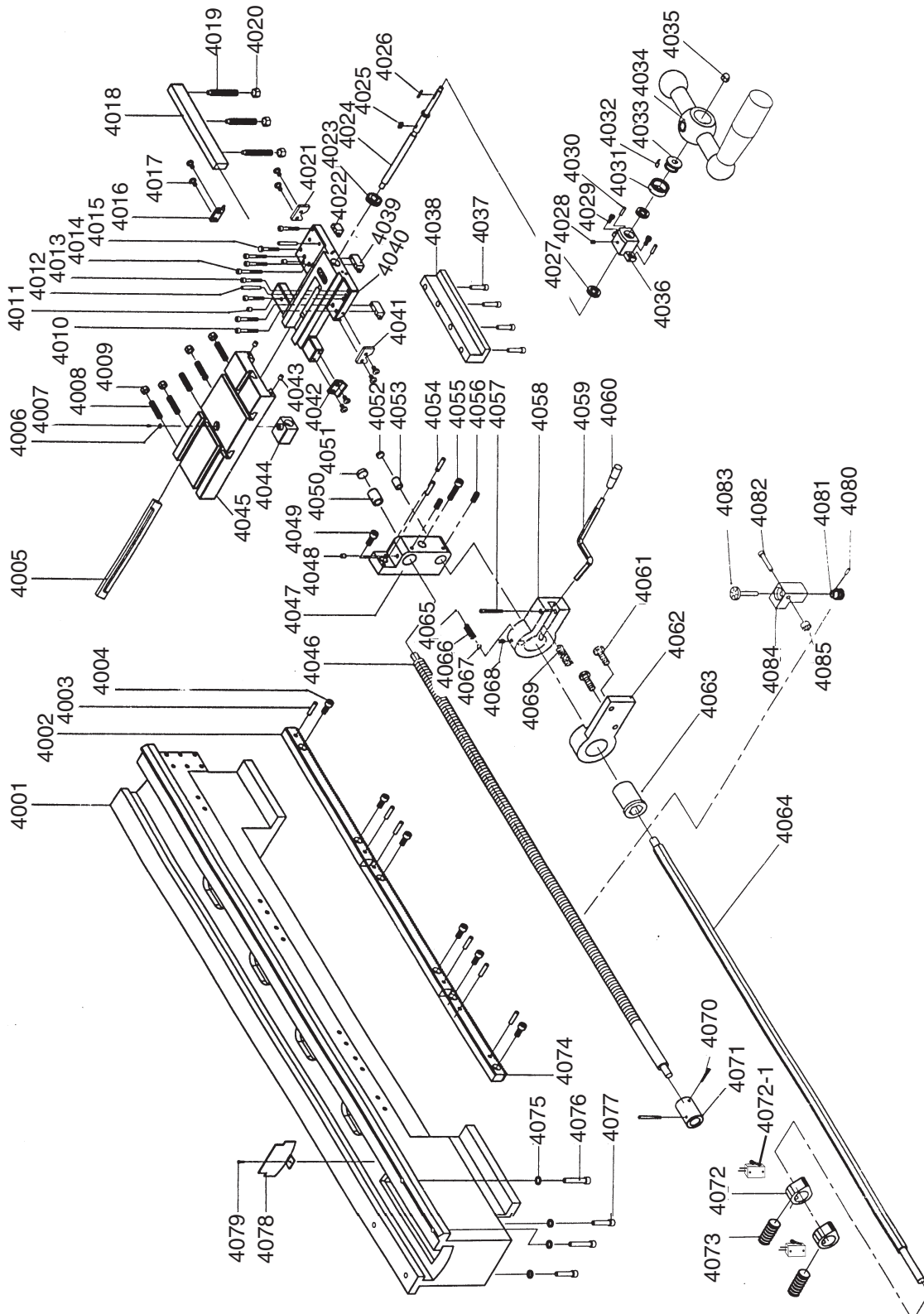

4000 Series Parts List

REF	PART #	DESCRIPTION
4001	P04924001	BED
4002	P04924002	RACK SET
4003	P04924003	TAPER PIN
4004	PSB11M	CAP SCREW M8-1.25 X 16
4005	P04924005	CHOCK
4006	P04924006	SPECIAL FLAT WASHER
4007	PS08M	PHLP HD SCR M5-.8 X 12
4008	PSS12M	SET SCREW SCR M6-1 X 25
4009	PN01M	HEX NUT M6-1
4010	PSB48M	CAP SCREW M6-1 X 35
4011	P04924011	BALL OILER 8MM
4012	P04924012	TAPER PIN
4013	PSB07M	CAP SCREW M6-1 X 30
4014	PSB30M	CAP SCREW M6-1 X 45
4015	PB47M	HEX BOLT M6-1 X 40
4016	P04924016	WIPER
4017	PFH07M	FLAT HD SCR M5-.8 X 10
4018	P04924018	CHOCK
4019	PSS09M	SET SCREW M8-1.25 X 20
4020	PN03M	HEX NUT M8-1.25
4021	P04924021	WIPER
4022	P04924022	BLOCK
4023	P04924023	GEAR (20-TOOTH)
4024	P04924024	CROSS FEED LEAD SCREW
4025	PK08M	KEY 5 X 5 X 16
4026	PK29M	KEY 4 X 4 X 8
4027	P8201	BALL BEARING 8201
4028	P04924028	STEEL BALL 6MM
4029	PB83M	HEX BOLT M6-1 X 16
4030	P04924030	TAPER PIN 5 X 20MM
4031	P04924031	DIAL
4032	P04924032	FLAT SPRING
4033	P04924033	DIAL SLEEVE
4034	P04924034	CRANK HANDLE
4035	PN41M	ACORN NUT M10-1.5
4036	P04924036	LEAD SCREW NUT HOUSING
4037	PSB12M	CAP SCREW M8-1.25 X 40
4038	P04924038	L-BLOCK LONG
4039	P04924039	L-BLOCK SMALL
4040	P04924040	CARRIAGE
4041	P04924041	WIPER
4042	P04924042	WIPER
4043	P04924028	BALL OILER 6MM

REF	PART #	DESCRIPTION
4044	P04924044	CROSS NUT
4045	P04924045	WORKTABLE
4046	P04924046	LONGITUDINAL FEED SCREW
4047	P04924047	LEADSCREW ENDCAP
4048	P04924028	BALL OILER 6MM
4049	PSB14M	CAP SCREW M8-1.25 X 20
4050	P04924050	SLEEVE
4051	P04924051	PLUG
4052	P04924052	PLUG
4053	P04924053	BUSHING
4054	P04924054	TAPER PIN
4055	PSB35M	CAP SCREW M8-1.25 X 60
4056	P04924056	SPECIAL SET SCREW M5-.8 X 10
4057	PRP91M	ROLL PIN 5 X 35
4058	P04924058	LOCKING HANDLE SEAT
4059	P04924059	LEVER
4060	P04924060	KNOB M10-1.5 FEMALE
4061	PSB26M	CAP SCREW M6-1 X 12
4062	P04924062	PEDESTAL
4063	P04924063	SLEEVE
4064	P04924064	CONTROL ROD
4065	P04924065	SPECIAL SET SCREW M8-1.25 X 8
4066	P04924066	COMPRESSION SPRING
4067	P04924028	STEEL BALL 6MM
4068	P04924068	SPECIAL SET SCREW M8-1.25 X 15
4069	P04924069	COMPRESSION SPRING
4070	P04924070	TAPER PIN
4071	P04924071	COUPLING SLEEVE
4072	P04924072	CAM LOBE
4072-1	P04924072-1	LIMIT SWITCH
4073	P04924073	SPECIAL SET SCREW M4-.7 X 6
4074	P04924074	RACK SET
4075	PW04M	FLAT WASHER 10MM
4076	PSB47M	CAP SCREW M10-1.5 X 40
4077	PSB84M	CAP SCREW M10-1.5 X 35
4078	P04924078	SHIELD
4079	PSB50M	CAP SCREW M5-.8 X 10
4080	P04924080	TAPER PIN
4081	P04924081	WORM WHEEL
4082	PSB29M	CAP SCREW M6-1 X 40
4083	P04924083	THREAD INDICATOR
4084	P04924084	THREAD DIAL HOUSING
4085	PN01M	HEX NUT M6-1



Steady Rest and Follow Rest Diagram (4500 Series Parts)

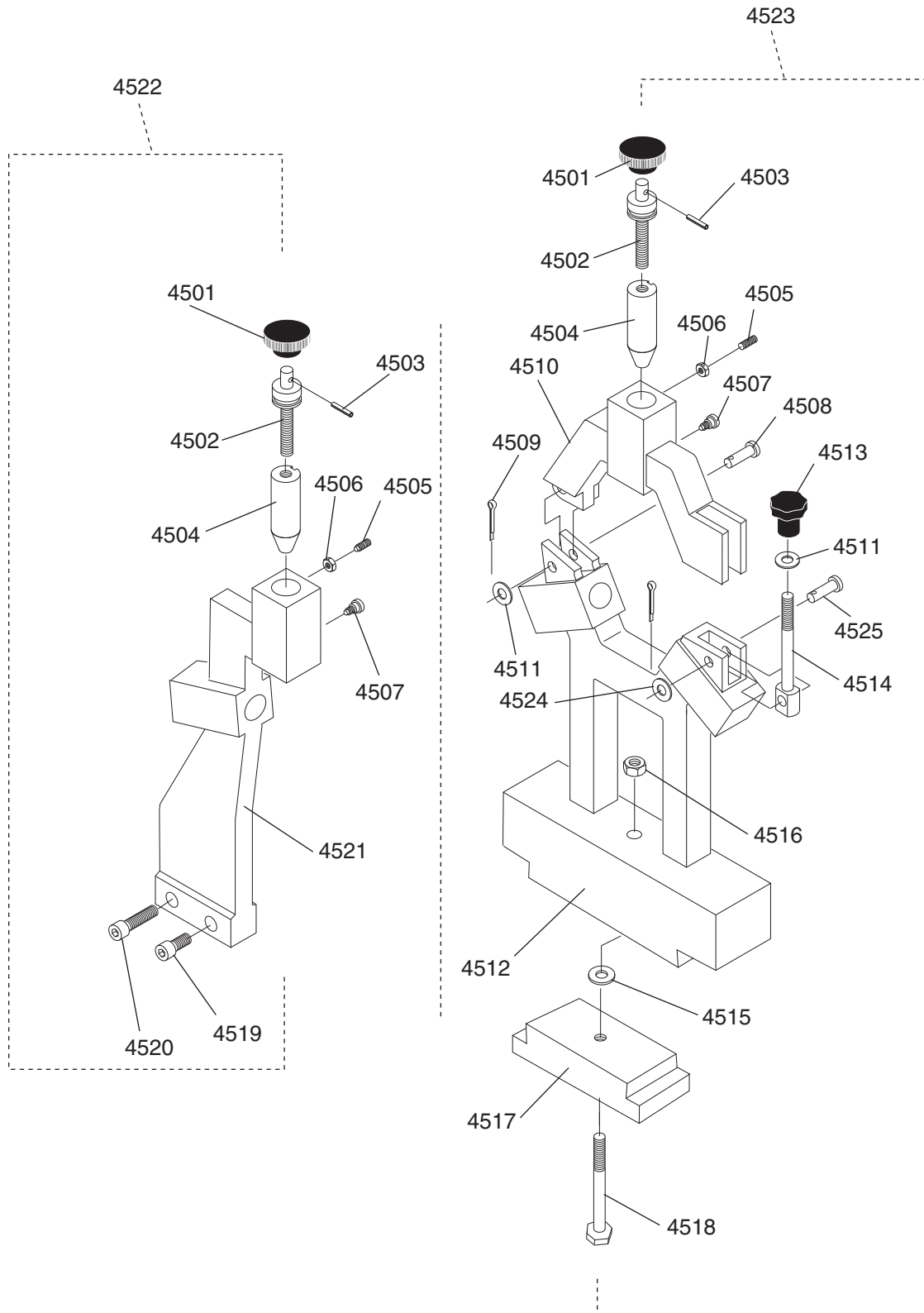

4500 Series Parts List

REF	PART #	DESCRIPTION
4501	P04924501	PINNED KNOB
4502	P04924502	ADJUSTMENT STUD
4503	P04924503	TAPERED PIN
4504	P04924504	BRASS-TIPPED FINGER
4505	P04924505	SPECIAL SET SCREW M6-1
4506	PN01M	HEX NUT M6-1
4507	P04924507	THUMB KNOB M6-1.0 X 20
4508	P04924508	CLEVIS PIN 8 X 32MM
4509	P04924509	COTTER PIN 3 X 25MM
4510	P04924510	STEADY REST HEAD
4511	PW01M	FLAT WASHER 8MM
4512	P04924512	STEADY REST BASE
4513	P04924513	FEMALE KNOB M8-1.25

REF	PART #	DESCRIPTION
4514	P04924514	SPECIAL EYE BOLT
4515	PW04M	FLAT WASHER 10MM
4516	PN02M	HEX NUT M10-1.5
4517	P04924517	CHOCK
4518	PB120M	HEX BOLT M10-1.5 X 65
4519	PSB14M	CAP SCREW M8-1.25 X 20
4520	PSB31M	CAP SCREW M8-1.25 X 25
4521	P04924521	FOLLOW REST CASTING
4522	P04924522	COMPLETE FOLLOW REST
4523	P04924523	COMPLETE STEADY REST
4524	PW03M	FLAT WASHER 6MM
4525	P04924525	CLEVIS PIN 6 X 32MM



Tailstock Diagram (5700 Series Parts)

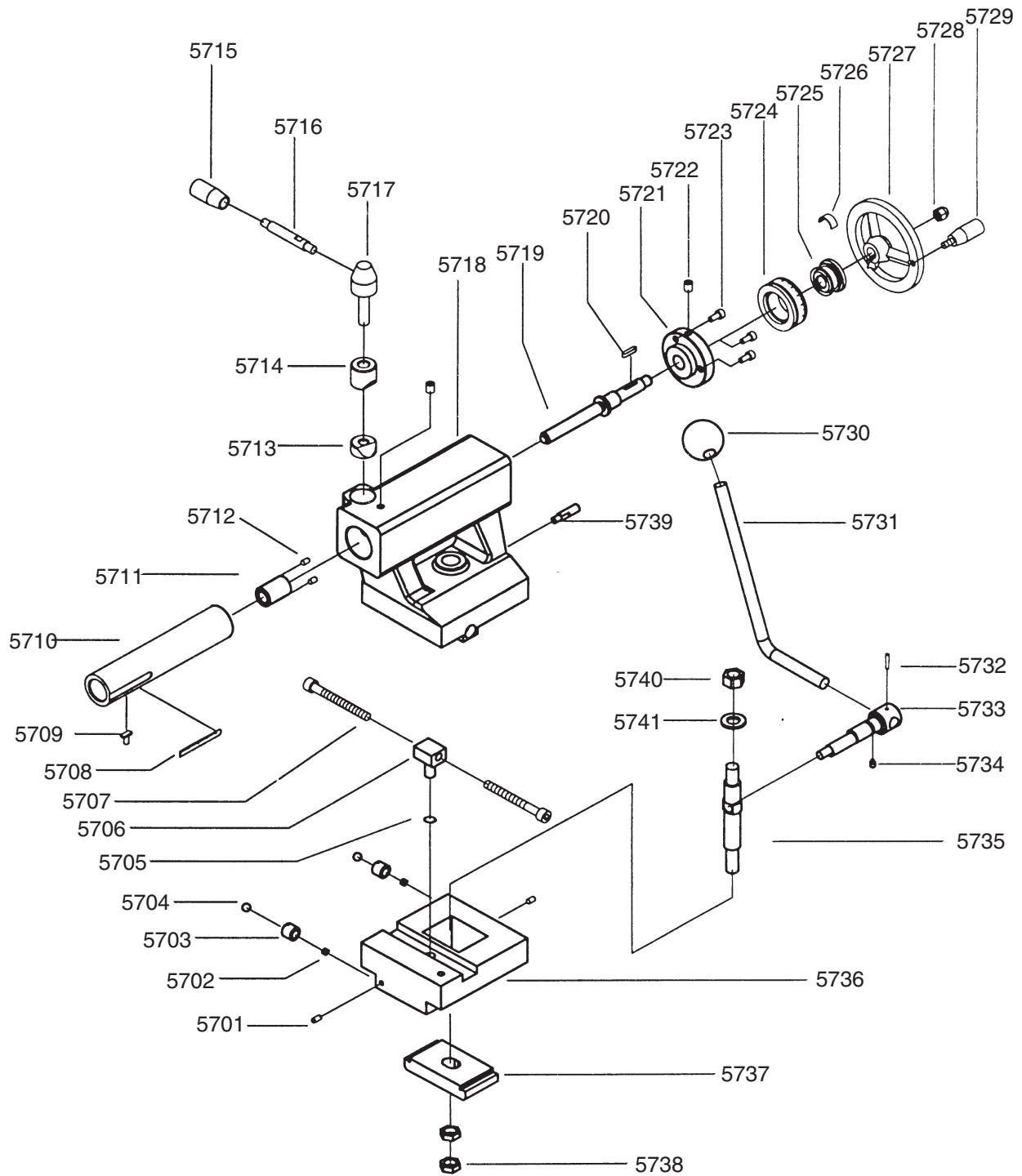

5700 Series Parts List

REF	PART #	DESCRIPTION
5701	P04925701	SPECIAL SET SCREW M5-.8 X 8
5702	P04925702	COMPRESSION SPRING
5703	P04925703	BALL OILER
5704	P04925704	STEEL BALL 8MM
5705	PR03M	EXT RETAINING RING 12MM
5706	P04925706	DOWEL NUT
5707	PSB12M	CAP SCREW M8-1.25 X 40
5708	P04925708	SCALE LABEL
5709	P04925709	T-KEY
5710	P04925710	BARREL
5711	P04925711	COLLAR SLEEVE
5712	P04925712	SPECIAL SET SCREW M5-.8 X 10
5713	P04925713	WEDGE NUT
5714	P04925714	WEDGE SLEEVE
5715	P04925715	KNOB M8-1.25 FEMALE
5716	P04925716	LEVER
5717	P04925717	LEVER HUB
5718	P04925718	TAILSTOCK HOUSING
5719	P04925719	TAILSTOCK STEM
5720	PK125M	KEY 4 X 4 X 28
5721	P04925721	FLANGE HUB

REF	PART #	DESCRIPTION
5722	P04921028	BALL OILER 6MM
5723	PSB33M	CAP SCREW M5-.8 X 12
5724	P04925724	DIAL
5725	P04925725	SLEEVE
5726	P04925726	FLAT SPRING
5727	P04925727	HAND WHEEL
5728	PN41M	ACORN NUT M10-1.5
5729	P04925729	HANDLE
5730	P04925730	KNOB M10-1.5 FEMALE
5731	P04925731	LEVER
5732	P04925732	TAPER PINS
5733	P04925733	SHAFT
5734	P04925734	SPECIAL SET SCREW M5-.8 X 12
5735	P04925735	PULL SHAFT
5736	P04925736	BASE
5737	P04925737	CHOCK
5738	P04925738	SPECIAL HEX NUT M12-1.5
5739	P04925739	PIN
5740	P04925740	SPECIAL HEX NUT M12-1.75
5741	PW06M	FLAT WASHER 12MM



Apron Diagram (6000 Series Parts)

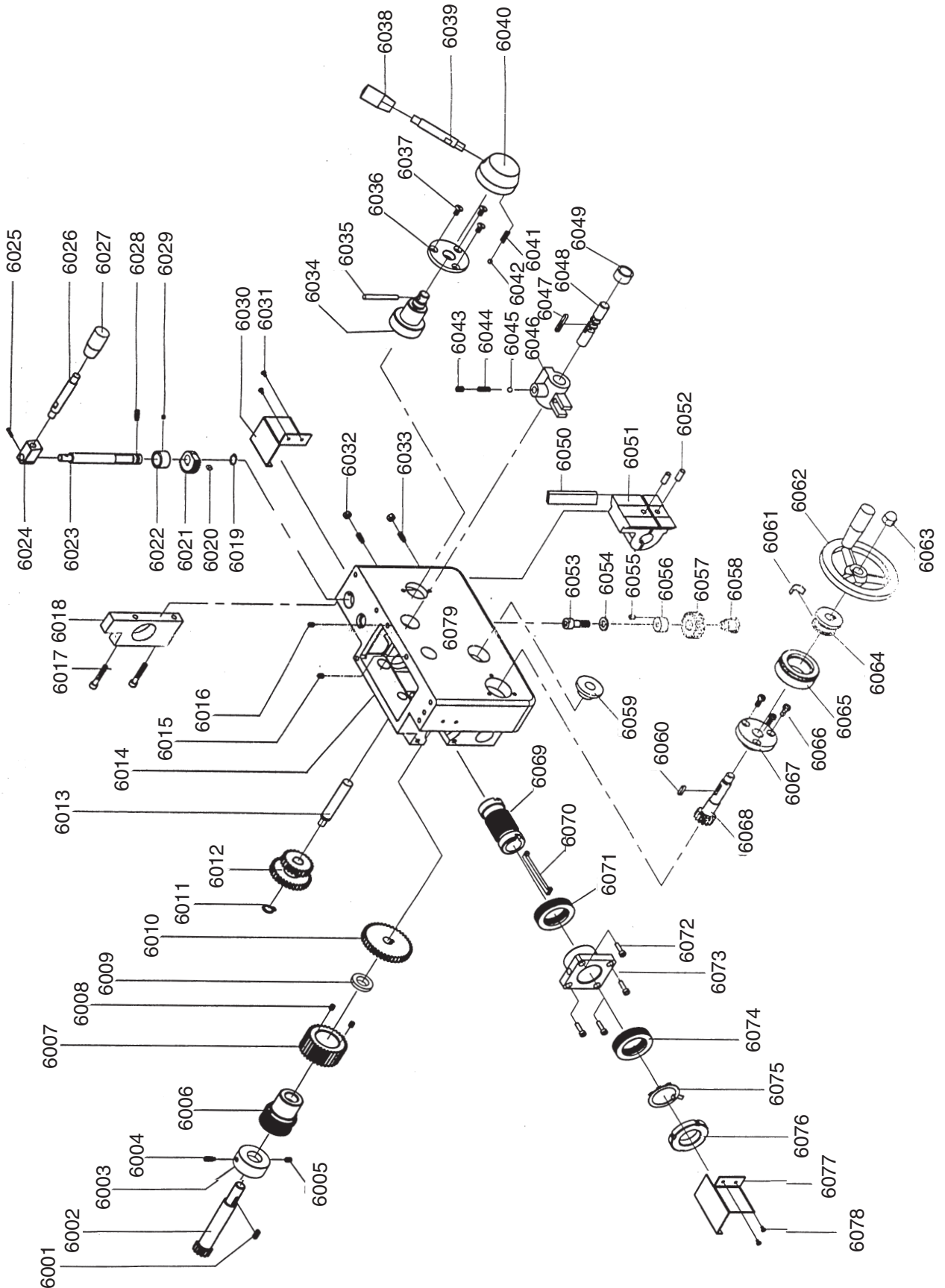

6000 Series Parts List

REF	PART #	DESCRIPTION
6001	PK81M	KEY 6 X 6 X 12
6002	P04926002	GEAR SHAFT
6003	P04926003	LOCK COLLAR
6004	PSS04M	SET SCREW M6-1 X 12
6005	P04926005	SPECIAL SET SCREW M6-1.0 X 12
6006	P04926006	WORM GEAR
6007	P04926007	GEAR (40-TOOTH)
6008	P04926008	SPECIAL SET SCREW M5-.8 X 8
6009	P04926009	SPACER
6010	P04926010	GEAR (60-TOOTH)
6011	PR09M	EXT RETAINING RING 20MM
6012	P04926012	CLUSTER GEAR
6013	P04926013	SHAFT
6014	P04926014	CASE
6015	P04926015	SPECIAL SET SCREW M5-.8 X 16
6016	P04926016	SPECIAL SET SCREW M6-1.0 X 20
6017	PSB79M	CAP SCREW M5-.8 X 35
6018	P04926018	APRON END BLOCK
6019	PR03M	EXT RETAINING RING 12MM
6020	PK29M	KEY 4 X 4 X 8
6021	P04926021	GEAR (30-TOOTH)
6022	P04926022	SPACER
6023	P04926023	SHAFT
6024	P04926024	ANGLE BLOCK
6025	P04926025	TAPER PIN
6026	P04926026	LEVER
6027	P04926027	KNOB M8-1.25 FEMALE
6028	PSS34M	SET SCREW M5-.8 X 16
6029	P04926029	SPECIAL SET SCREW M5-.8 X 8
6030	P04926030	COVER
6031	PS05M	PHLP HD SCR M5-.8 X 8
6032	PN06M	HEX NUT M5-.8
6033	P04926033	SPECIAL SET SCREW M5-.8 X 25
6034	P04926034	STUB HUB
6035	P04926035	TAPER PIN
6036	P04926036	FLANGE HUB
6037	PFH25M	FLAT HD SCR M4-.7 X 12
6038	P04926038	KNOB M8-1.25 FEMALE
6039	P04926039	LEVER
6040	P04926040	LEVER HUB

REF	PART #	DESCRIPTION
6041	P04926041	COMPRESSION SPRING
6042	P04926042	STEEL BALL 6.5MM
6043	P04926043	SPECIAL SET SCREW M6-1.0 X 8
6044	P04926044	COMPRESSION SPRING
6045	P04926045	STEEL BALL 5MM
6046	P04926046	SHIFTING FORK
6047	PK02M	KEY 5 X 5 X 40
6048	P04926048	SHIFTING FORK SHAFT
6049	P04926049	SLEEVE
6050	P04926050	GIB
6051	P04926051	HALF NUT SET
6052	P04926052	ALIGNMENT PINS 6 X 8MM
6053	PSB06M	CAP SCREW M6-1 X 25
6054	PLW03M	LOCK WASHER 6MM
6055	P04926055	SPECIAL SET SCREW M4-.7 X 8
6056	P04926056	SLEEVE
6057	P04926057	MIDDLE GEAR
6058	P04926058	STUB HUB
6059	P04926059	BEARING SLEEVE
6060	PK125M	KEY 4 X 4 X 28
6061	P04926061	FLAT SPRING
6062	P04926062	HAND WHEEL
6063	PN42M	ACORN NUT M12 X 1.5
6064	P04926064	SLEEVE
6065	P04926065	DIAL
6066	PS02M	PHLP HD SCR M4-.7 X 12
6067	P04926067	FLANGE SLEEVE
6068	P04926068	GEAR SHAFT
6069	P04926069	WORM SHAFT
6070	P04926070	SADDLE KEY 4 X 28
6071	P8106	THRUST BEARING 8106
6072	PSB24M	CAP SCREW M5-.8 X 16
6073	P04926073	FIXED FLANGE HUB
6074	P8106	THRUST BEARING 8106
6075	P04926075	TANG WASHER
6076	P04926076	SPANNER NUT M30-1.5
6077	P04926077	PLATE
6078	PS05M	PHLP HD SCR M5-.8 X 8
6079	P04926079	HOUSING



Headstock Diagram (7500 Series Parts)

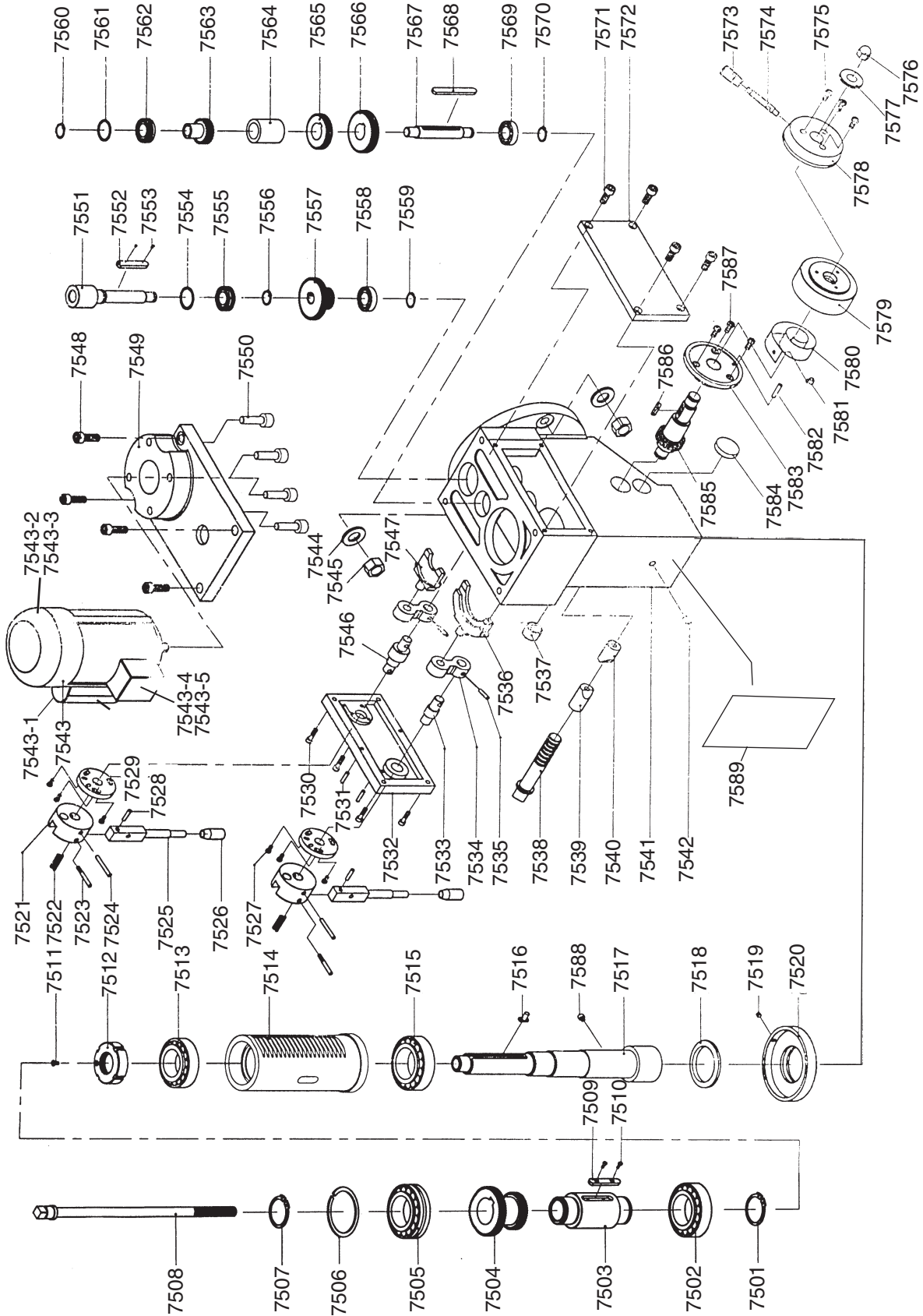

7500 Series Parts List

REF	PART #	DESCRIPTION
7501	PR12M	EXT RETAINING RING 35MM
7502	P04927502	ROLLER BEARING 207
7503	P04927503	SHAFT SLEEVE
7504	P04927504	CLUSTER GEAR
7505	P04927505	BALL BEARING 50207
7506	P04927506	BEARING LOOP
7507	PR12M	EXT RETAINING RING 35MM
7508	P04927508	DRAW BAR 7/16-20
7509	P04927509	SPECIAL KEY
7510	P04927510	SPECIAL SET SCREW M3-.5 X 8
7511	PFH31M	FLAT HD SCR M4-.7 X 8
7512	P04927512	SPANNER NUT M30-1.5
7513	P04927513	TAPER ROLLER BEARING 2007106
7514	P04927514	RACK
7515	P04927515	TAPER ROLLER BEARING D2007107
7516	P04927516	T-KEY
7517	P04927517	SPINDLE (R8)
7518	P04927518	FELT SEAT
7519	P04927519	SPECIAL SET SCREW M4-.7 X 12
7520	P04927520	BEARING CAP
7521	P04927521	LEVER HUB
7522	P04927522	COMPRESSION SPRING
7523	P04927523	PIVOT STUD
7524	P04927524	TAPER PIN
7525	P04927525	LEVER
7526	P04927526	KNOB M8-1.25 FEMALE
7527	PSB18M	CAP SCREW M4-.7 X 8
7528	P04927528	STRAIGHT PIN
7529	P04927529	LOCATING PLATE
7530	PSB24M	CAP SCREW M5-.8 X 16
7531	P04927531	TAPER PIN
7532	P04927532	SHIFTER COVER
7533	P04927533	SHIFTING FORK SHAFT
7534	P04927534	ROCKER ARM
7535	P04927535	TAPER PIN
7536	P04927536	LARGE SHIFT FORK
7537	P04927537	END SLEEVE
7538	P04927538	LOCK STUD
7539	P04927539	SLEEVE NUT
7540	P04927540	WEDGE NUT
7541	P04927541	GEARBOX CASE
7542	PSB76M	CAP SCREW M8-1.25 X 18
7543	P04927543	MOTOR 220V 3/4 HP
7543-1	P04927543-1	CAPACITOR 200UF/250VAC
7543-2	P04927543-2	FAN COVER
7543-3	P04927543-3	FAN
7543-4	P04927543-4	POWER SWITCH (KJD12, 230VAC, 5E4)

REF	PART #	DESCRIPTION
7543-5	P04927543-5	POWER SWITCH BOX
7544	PW04M	FLAT WASHER 10MM
7545	PN02M	HEX NUT M10-1.5
7546	P04927546	SHIFTING FORK SHAFT
7547	P04927547	SMALL SHIFTING FORK
7548	PSB14M	CAP SCREW M8-1.25 X 20
7549	P04927549	MOTOR MOUNT PLATE
7550	PSB02M	CAP SCREW M6-1 X 20
7551	P04927551	INPUT SHAFT
7552	PK112M	KEY 5 X 5 X 50
7553	P04927553	SPECIAL SCREW
7554	P04927554	BEARING LOOP
7555	P50207	BALL BEARING 50207
7556	PR18M	EXT RETAINING RING 17MM
7557	P04927557	CLUSTER GEAR
7558	P60201	BALL BEARING 60201
7559	PR03M	EXT RETAINING RING 12MM
7560	PR03M	EXT RETAINING RING 12MM
7561	P04927561	BEARING LOOP
7562	P50207	BALL BEARING 50207
7563	P04927563	GEAR (21-TOOTH)
7564	P04927564	SPACER
7565	P04927565	GEAR (39-TOOTH)
7566	P04927566	GEAR (45-TOOTH)
7567	P04927567	IDLER SHAFT
7568	PK112M	KEY 5 X 5 X 55
7569	P60201	BALL BEARING 60201
7570	PR03M	EXT RETAINING RING 12MM
7571	PSB24M	CAP SCREW M5-.8 X 16
7572	P04927572	GEARBOX COVER
7573	P04927573	KNOB M8-1.25 FEMALE
7574	P04927574	LEVER
7575	PFH41M	FLAT HD SCR M4-.7 X 16
7576	PN18M	ACORN NUT M8-1.25
7577	P04927577	ADJUSTMENT WASHER
7578	P04927578	LEVER HUB
7579	P04927579	CALIBRATED DIAL
7580	P04927580	COILED FLAT SPRING
7581	PS07M	PHLP HD SCR M4-.7 X 8
7582	P04927582	PIN
7583	P04927583	FLANGE HUB
7584	P04927584	CAP
7585	P04927585	PINION GEAR SHAFT
7586	PK06M	KEY 5 X 5 X 10
7587	PB96M	HEX BOLT M5-.8 X 10
7588	P04927588	SPECIAL SHOULDER SCREW
7589	P04927589	CONVERSION DATA PLATE



Mill Column Diagram (8000 Series Parts)

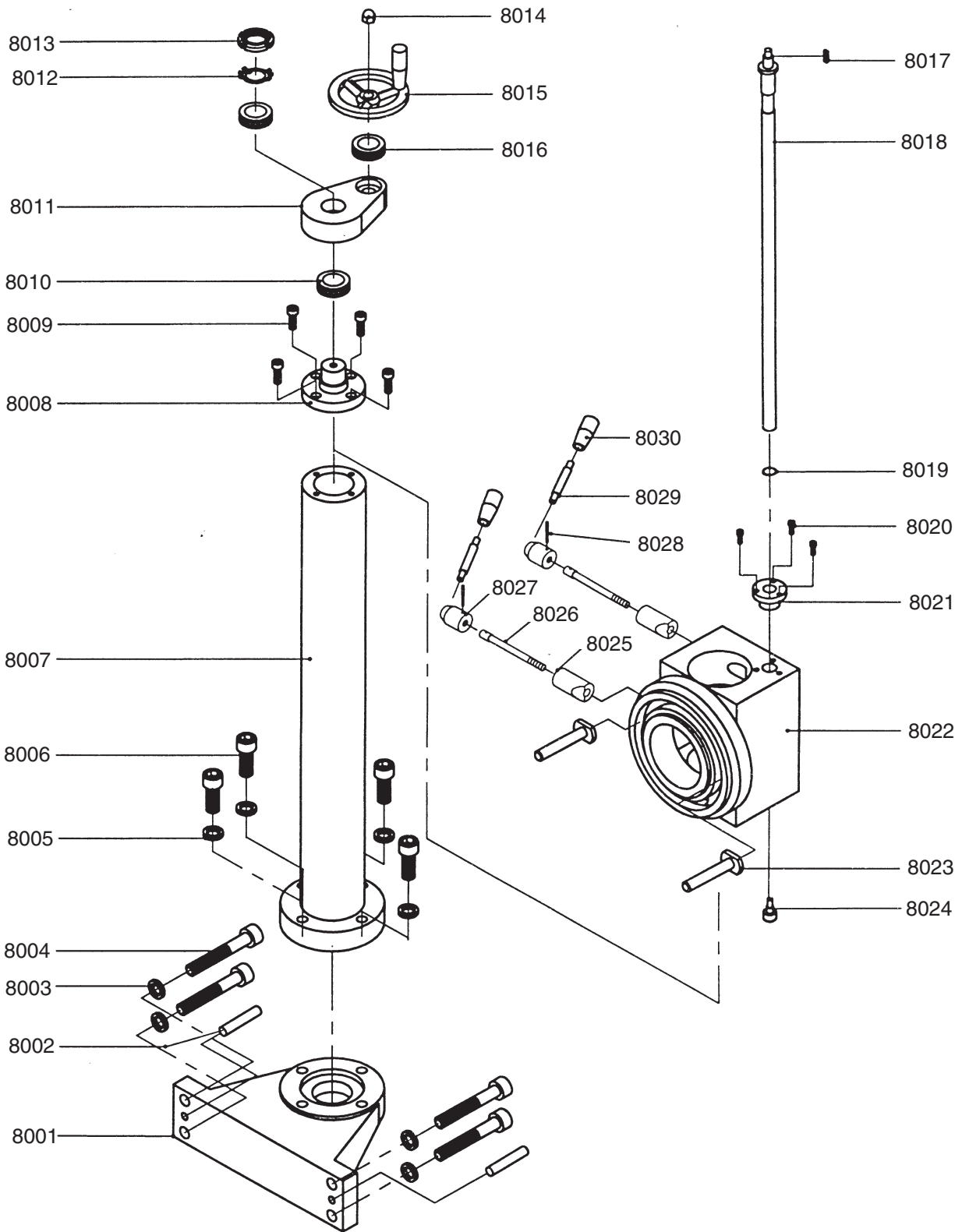

8000 Series Parts List

REF	PART #	DESCRIPTION
8001	P04928001	PEDESTAL
8002	P04928002	TAPER PIN
8003	PLW05M	LOCK WASHER 12MM
8004	PSB92M	CAP SCREW M12-1.75 X 40
8005	PLW05M	LOCK WASHER 12MM
8006	PSB119M	CAP SCREW M12-1.75 X 55
8007	P04928007	COLUMN
8008	P04928008	COLUMN FLANGE
8009	PSB02M	CAP SCREW M6-1 X 20
8010	P8106	BALL BEARING 8106
8011	P04928011	COLUMN BRACKET
8012	P04928012	TANG WASHER
8013	P04928013	SPANNER NUT M30-1.5
8014	PN41M	ACORN NUT M10-1.5
8015	P04928015	HAND WHEEL

REF	PART #	DESCRIPTION
8016	P8103	BALL BEARING 8103
8017	PK69M	KEY 4 X 4 X 12
8018	P04928018	HEADSTOCK LEAD SCREW
8019	PR18M	EXT RETAINING RING 17MM
8020	PSB06M	CAP SCREW M6-1 X 25
8021	P04928021	LEADSCREW NUT
8022	P04928022	COLUMN BRACKET
8023	P04928023	T-BOLT
8024	P04928024	SPECIAL SHOULDER SCREW
8025	P04928025	WEDGE SLEEVE
8026	P04928026	LOCK STUD
8027	P04928027	LEVER HUB
8028	P04928028	TAPER PIN
8029	P04928029	LEVER
8030	P04928030	KNOB M8-1.25 FEMALE



Accessories and Labels Diagram (9000 Series Parts)

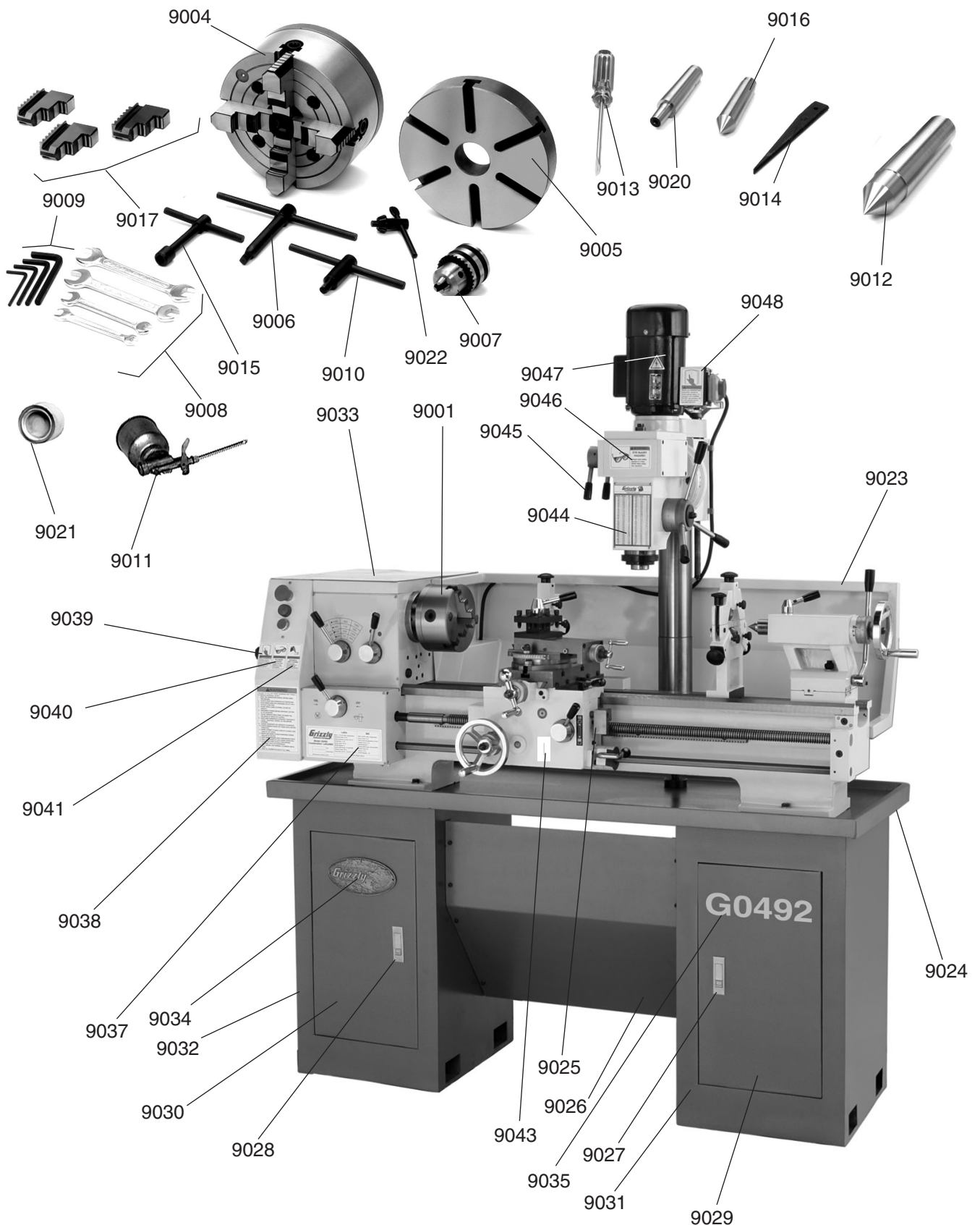

9000 Series Parts List

REF	PART #	DESCRIPTION
9001	P04929001	6" THREE-JAW CHUCK
9004	P04929004	8" FOUR-JAW UNIVERSAL CHUCK
9005	P04929005	8" FACEPLATE
9006	P04929006	FOUR-JAW CHUCK KEY
9007	P04929007	DRILL CHUCK (1-13MM, JT-33)
9008	P04929008	WRENCH SET (8/10, 10/12, 14/17, 17/19 MM)
9008-1	P04929008-1	COMBINATION WRENCH 8/10
9008-2	P04929008-2	COMBINATION WRENCH 10/12
9008-3	P04929008-3	COMBINATION WRENCH 14/17
9008-4	P04929008-4	COMBINATION WRENCH 17/19
9009	P04929009	HEX WRENCH SET (2, 4, 6, 8, MM)
9009-1	PAW02M	HEX WRENCH 4MM
9009-2	PAW04M	HEX WRENCH 4MM
9009-3	PAW06M	HEX WRENCH 6MM
9009-4	PAW08M	HEX WRENCH 8MM
9010	P04929010	THREE-JAW CHUCK KEY
9011	P04929011	OIL CAN
9012	P04929012	DEAD CENTER MT#5
9013	P04929013	STANDARD SCREWDRIVER #2
9014	P04929014	WEDGE
9015	P04929015	TOOL POST T-HANDLE WRENCH
9016	P04929016	DEAD CENTER MT#3
9017	P04929017	THREE-JAW CHUCK INT. JAWS
9020	P04929020	ARBOR JT-33 TO MT#3
9021	P04929021	SPOT PAINT

REF	PART #	DESCRIPTION
9022	P04929022	DRILL CHUCK KEY
9023	P04929023	BACK SPLASH
9024	P04929024	CHIP TRAY
9025	P04929025	THREAD DIAL
9026	P04929026	KICK PANEL
9027	P04929027	COMPLETE RT DOOR LATCH ASSY
9028	P04929028	COMPLETE LFT DOOR LATCH ASSY
9029	P04929029	RT DOOR W/HINDGES AND LOCK
9030	P04929030	LFT DOOR W/HINDGES AND LOCK
9031	P04929031	COMPLETE RT CABINET W/DOOR
9032	P04929032	COMPLETE LFT CABINET W/DOOR
9033	P04929033	RUBBER MAT
9034	P04929034	GRIZZLY LOGO PLATE
9035	P04929035	G0492 LABEL
9037	P04929037	DATA LABEL
9038	P04929038	GENERAL WARNING LABEL
9039	P04929039	WEAR EYEPROTECTION LABEL
9040	P04929040	READ MANUAL FIRST LABEL
9041	P04929041	TIE BACK LOOSE CLOTHING LABEL
9043	P04929043	THREAD DIAL CHART LABEL
9044	P04929044	INCH/METRIC CONVERSION CHART
9045	P04929045	MILL GEAR BOX SPEED LABEL
9046	P04929046	WEAR EYEPROTECTION LABEL
9047	P04929047	ELECTRICAL HAZARD LABEL
9048	P04929048	READ MANUAL FIRST LABEL



WARRANTY AND RETURNS

Grizzly Industrial, Inc. warrants every product it sells for a period of **1 year** to the original purchaser from the date of purchase. This warranty does not apply to defects due directly or indirectly to misuse, abuse, negligence, accidents, repairs or alterations or lack of maintenance. This is Grizzly's sole written warranty and any and all warranties that may be implied by law, including any merchantability or fitness, for any particular purpose, are hereby limited to the duration of this written warranty. We do not warrant or represent that the merchandise complies with the provisions of any law or acts unless the manufacturer so warrants. In no event shall Grizzly's liability under this warranty exceed the purchase price paid for the product and any legal actions brought against Grizzly shall be tried in the State of Washington, County of Whatcom.

We shall in no event be liable for death, injuries to persons or property or for incidental, contingent, special, or consequential damages arising from the use of our products.

To take advantage of this warranty, contact us by mail or phone and give us all the details. We will then issue you a "Return Number," which must be clearly posted on the outside as well as the inside of the carton. We will not accept any item back without this number. Proof of purchase must accompany the merchandise.

The manufacturers reserve the right to change specifications at any time because they constantly strive to achieve better quality equipment. We make every effort to ensure that our products meet high quality and durability standards and we hope you never need to use this warranty.

Please feel free to write or call us if you have any questions about the machine or the manual.

Thank you again for your business and continued support. We hope to serve you again soon.



Grizzly WARRANTY CARD
Industrial, Inc.

Name _____
 Street _____
 City _____ State _____ Zip _____
 Phone # _____ Email _____ Invoice # _____
 Model # _____ Order # _____ Serial # _____

The following information is given on a voluntary basis. It will be used for marketing purposes to help us develop better products and services. **Of course, all information is strictly confidential.**

1. How did you learn about us?

<input type="checkbox"/> Advertisement	<input type="checkbox"/> Friend	<input type="checkbox"/> Catalog
<input type="checkbox"/> Card Deck	<input type="checkbox"/> Website	<input type="checkbox"/> Other:

2. Which of the following magazines do you subscribe to?

<input type="checkbox"/> Cabinet Maker	<input type="checkbox"/> Popular Mechanics	<input type="checkbox"/> Today's Homeowner
<input type="checkbox"/> Family Handyman	<input type="checkbox"/> Popular Science	<input type="checkbox"/> Wood
<input type="checkbox"/> Hand Loader	<input type="checkbox"/> Popular Woodworking	<input type="checkbox"/> Wooden Boat
<input type="checkbox"/> Handy	<input type="checkbox"/> Practical Homeowner	<input type="checkbox"/> Woodshop News
<input type="checkbox"/> Home Shop Machinist	<input type="checkbox"/> Precision Shooter	<input type="checkbox"/> Woodsmith
<input type="checkbox"/> Journal of Light Cont.	<input type="checkbox"/> Projects in Metal	<input type="checkbox"/> Woodwork
<input type="checkbox"/> Live Steam	<input type="checkbox"/> RC Modeler	<input type="checkbox"/> Woodworker West
<input type="checkbox"/> Model Airplane News	<input type="checkbox"/> Rifle	<input type="checkbox"/> Woodworker's Journal
<input type="checkbox"/> Modeltec	<input type="checkbox"/> Shop Notes	<input type="checkbox"/> Other:
<input type="checkbox"/> Old House Journal	<input type="checkbox"/> Shotgun News	

3. What is your annual household income?

<input type="checkbox"/> \$20,000-\$29,000	<input type="checkbox"/> \$30,000-\$39,000	<input type="checkbox"/> \$40,000-\$49,000
<input type="checkbox"/> \$50,000-\$59,000	<input type="checkbox"/> \$60,000-\$69,000	<input type="checkbox"/> \$70,000+

4. What is your age group?

<input type="checkbox"/> 20-29	<input type="checkbox"/> 30-39	<input type="checkbox"/> 40-49
<input type="checkbox"/> 50-59	<input type="checkbox"/> 60-69	<input type="checkbox"/> 70+

5. How long have you been a woodworker/metalworker?

<input type="checkbox"/> 0-2 Years	<input type="checkbox"/> 2-8 Years	<input type="checkbox"/> 8-20 Years	<input type="checkbox"/> 20+ Years
------------------------------------	------------------------------------	-------------------------------------	------------------------------------

6. How many of your machines or tools are Grizzly?

<input type="checkbox"/> 0-2	<input type="checkbox"/> 3-5	<input type="checkbox"/> 6-9	<input type="checkbox"/> 10+
------------------------------	------------------------------	------------------------------	------------------------------

7. Do you think your machine represents a good value? Yes No
8. Would you recommend Grizzly Industrial to a friend? Yes No
9. Would you allow us to use your name as a reference for Grizzly customers in your area?
Note: We never use names more than 3 times. Yes No

10. Comments: _____

CUT ALONG DOTTED LINE



FOLD ALONG DOTTED LINE



Place
Stamp
Here



GRIZZLY INDUSTRIAL, INC.
P.O. BOX 2069
BELLINGHAM, WA 98227-2069



FOLD ALONG DOTTED LINE

Send a Grizzly Catalog to a friend:

Name _____
Street _____
City _____ State _____ Zip _____

TAPE ALONG EDGES--PLEASE DO NOT STAPLE

grizzly.com

TOOL WEBSITE

Buy Direct and Save with Grizzly® – Trusted, Proven and a Great Value!

*Visit Our Website Today And Discover
Why Grizzly® Is The Industry Leader!*

- SECURE ORDERING
- ORDERS SHIPPED WITHIN 24 HOURS
- E-MAIL RESPONSE WITHIN ONE HOUR

-OR-

Call Today For A **FREE**
Full Color Catalog

1-800-523-4777

