

# Models

Triplex Ceramic  
Plunger Pump  
Models Manual

# GP8055, GP8060, GP8065

---

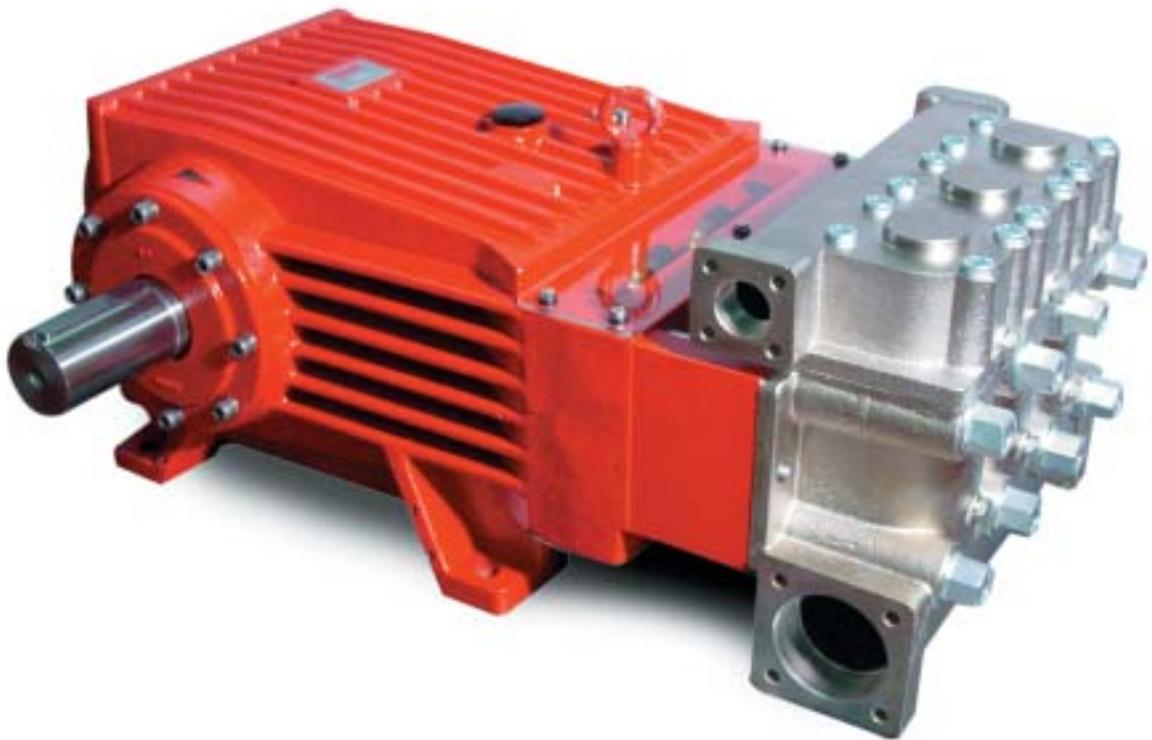

Updated 3/07

## Contents:

Installation Instructions:	page 2
Pump Specifications:	page 3-5
Exploded View/Parts List:	pages 6-7
Repair Kits/Tool List:/Torque Specifications	page 8
Troubleshooting Chart:	page 8
Repair Instructions:	pages 9-11
Dimensions:	back page
Warranty Information	back page

# INSTALLATION INSTRUCTIONS

**Installation of the Giant Industries, Inc., pump is not a complicated procedure, but there are some basic steps common to all pumps. The following information is to be considered as a general outline for installation. If you have unique requirements, please contact Giant Industries, Inc. or your local distributor for assistance.**

1. The pump should be installed flat on a base to a maximum of a 15 degree angle of inclination to ensure optimum lubrication.
2. The inlet to the pump should be sized for the flow rate of the pump with no unnecessary restrictions that can cause cavitation. Teflon tape should be used to seal all joints. If pumps are to be operated at temperatures in excess of 140° F, it is important to insure a positive head to the pump to prevent cavitation.
3. The discharge plumbing from the pump should be properly sized to the flow rate to prevent line pressure loss to the work area. It is essential to provide a safety bypass valve between the pump and the work area to protect the pump from pressure spikes in the event of a blockage or the use of a shut-off gun.
4. Use of a dampener is necessary to minimize pulsation at drive elements, plumbing, connections, and other system areas. The use of a dampener with Giant Industries, Inc. pumps is optional, although recommended by Giant Industries, Inc. to further reduce system pulsation. Dampeners can also reduce the severity of pressure spikes that occur in systems using a shut-off gun. A dampener must be positioned downstream from the unloader.

## **IMPORTANT OPERATING CONDITIONS** **Failure to comply with any of these conditions invalidates the warranty**

1. Prior to initial operation, add oil to crankcase so that oil level is between the two lines on the oil dipstick. **DO NOT OVERFILL. Use Industrial synthetic gear lube oil (ISO VG 220), such as Mobil Gear 630, Shell Oamala oil 220 or Texaco Meropa 220.** Crankcase oil should be changed after the first 50 hours of operation, then at regular intervals of 500 hours or less depending on operating conditions.
2. Pump operation must not exceed rated pressure, volume, or RPM. A pressure relief device must be installed in the discharge of the system.
3. Acids, alkalines, or abrasive fluids cannot be pumped unless approval in writing is obtained before operation from Giant Industries, Inc. Pump fluid should be filtered to 300 micron.

5. Crankshaft rotation on Giant Industries, Inc. pumps should be made in the direction designated by the arrows on the pump crankcase. Reverse rotation may be safely achieved by following a few guidelines available upon request from Giant Industries, Inc. Required horsepower for system operation can be obtained from the charts on pages 3- 6.

6. Before beginning operation of your pumping system, remember: Check that the crankcase and seal areas have been properly lubricated per recommended schedules. Do not run the pump dry for extended periods of time. Cavitation will result in severe damage. Always remember to check that all plumbing valves are open and that pumped media can flow freely to the inlet of the pump.

**Important!** The service life of the seals is maximized if a minimal amount of leakage is present. A few drops of water can drip from each plunger every minute. Leakage has to be examined every day; the plunger seals must be changed should leakage become excessive (=constant dripping).

Finally, remember that high pressure operation in a pump system has many advantages. But, if it is used carelessly and without regard to its potential hazard, it can cause serious injury.

4. Run the pump dry approximately 10 seconds to drain the water before exposure to freezing temperatures.

5. **Important!** The pump and cooling system must be emptied if there is a danger of frost. Note that travel wind, for example, can cause water in pumps fitted on open vehicles to freeze even if the outside temperature is above freezing point.

To empty the cooling circuit, remove the L-joints (K11) on the pump head (50). Blow out the circuit liquid at the joint connection (K11/K7) using compressed air.

The torque tension on the valve casing nuts (49A) should be checked after approximately 200 operating hours. Please see page 8 for torque values.

# Specifications

## Model GP8055

	U.S.	(Metric)
Volume .....	Up to 75.5 GPM .....	(285 LPM)
Discharge Pressure .....	Up to 3000 PSI .....	(200 bar)
Speed .....	Up to 580 RPM .....	580 RPM
Inlet Pressure .....	Up to 29 PSI.....	(2.0 bar)
Plunger Diameter .....	2.17" .....	55mm
Plunger Stroke .....	2.83" .....	72mm
Crankshaft Diameter .....	2.76" .....	70mm
Key Width.....	0.55" .....	14mm
Crankshaft Mounting .....	Either side	
Shaft Rotation .....	Top of pulley towards manifold	
Temperature of Pumped Fluids .....	Up to 140 °F .....	(60 °C)
Inlet Ports .....	(2) 3" BSPP	
Discharge Ports .....	(2) 1-1/4" BSPP	
Weight .....	705 lbs. ....	(320kg)
Crankcase Oil Capacity .....	3.3 Gal. ....	(12.5 liters)
Fluid End Material .....	Nickle plated Spheroidal Cast Iron	

Consult the factory for special requirements that must be met if the pump is to operate beyond one or more of the limits specified above.

<b>GP8055 HORSEPOWER REQUIREMENTS</b>					
RPM	GPM	500 PSI	1000 PSI	2000 PSI	3000 PSI
300	39	13.9	27.9	55.7	83.6
400	52	18.6	37.1	74.3	111.4
500	65	23.2	46.4	92.9	139.3
580	75.5	27.0	53.9	107.9	161.8

**HORSEPOWER RATINGS:**

The rating shown are the power requirements for the pump. Gas engine power outputs must be approximately twice the pump power requirements shown above.

We recommend a 1.1 service factor be specified when selecting an electric motor as the power source. To compute specific pump horse power requirements, use the following formula:

$$\frac{\text{GPM X PSI}}{1400} = \text{HP}$$

**SPECIAL NOTE:**

The theoretical gallons per revolution (gal/rev) is 0.130.  
 To find specific outputs at various RPM, use the formula:

$$\text{GPM} = 0.130 \times \text{RPM}$$

# Specifications Model GP8060

	U.S.	(Metric)
Volume .....	Up to 90 GPM .....	(341 LPM)
Discharge Pressure .....	Up to 2500 PSI .....	(172 bar)
Speed .....	Up to 580 RPM .....	580 RPM
Inlet Pressure .....	Up to 29 PSI.....	(2.0 bar)
Plunger Diameter .....	2.36" .....	60mm
Plunger Stroke .....	2.83" .....	72mm
Crankshaft Diameter .....	2.76" .....	70mm
Key Width.....	0.55" .....	14mm
Crankshaft Mounting .....		Either side
Shaft Rotation .....		Top of pulley towards manifold
Temperature of Pumped Fluids .....	Up to 140 °F .....	(60 °C)
Inlet Ports .....		(2) 3" BSPP
Discharge Ports .....		(2) 1-1/4" BSPP
Weight .....	705 lbs./ .....	(320kg)
Crankcase Oil Capacity .....	3.3 Gal. ....	(12.5 liters)
Fluid End Material .....		Nickle plated Spheroidal Cast Iron

Consult the factory for special requirements that must be met if the pump is to operate beyond one or more of the limits specified above.

<b>GP8060 HORSEPOWER REQUIREMENTS</b>					
RPM	GPM	500 PSI	1000 PSI	2000 PSI	2500 PSI
300	47	16.8	33.6	67.1	83.9
400	62	22.1	44.3	88.6	110.7
500	78	27.9	55.7	111.4	139.3
580	90	32.1	64.3	128.6	160.7

**HORSEPOWER RATINGS:**

The rating shown are the power requirements for the pump. Gas engine power outputs must be approximately twice the pump power requirements shown above.

We recommend a 1.1 service factor be specified when selecting an electric motor as the power source. To compute specific pump horse power requirements, use the following formula:

$$\frac{\text{GPM} \times \text{PSI}}{1400} = \text{HP}$$

**SPECIAL NOTE:**

The theoretical gallons per revolution (gal/rev) is 0.155.  
To find specific outputs at various RPM, use the formula:

GPM = 0.155 x RPM

# Specifications Model GP8065

	U.S.	(Metric)
Volume .....	Up to 105 GPM .....	(400 LPM)
Discharge Pressure .....	Up to 2000 PSI .....	(140 bar)
Speed .....	Up to 580 RPM .....	580 RPM
Inlet Pressure .....	Up to 29 PSI .....	(2.0 bar)
Plunger Diameter .....	2.55" .....	65mm
Plunger Stroke .....	2.83" .....	72mm
Crankshaft Diameter .....	2.76" .....	70mm
Key Width .....	0.55" .....	14mm
Crankshaft Mounting .....	Either side	
Shaft Rotation .....	Top of pulley towards manifold	
Temperature of Pumped Fluids .....	Up to 140 °F .....	(60 °C)
Inlet Ports .....	(2) 3" BSPP	
Discharge Ports .....	(2) 1-1/4" BSPP	
Weight .....	705 lbs. ....	(320kg)
Crankcase Oil Capacity .....	3.3 Gal. ....	(12.5 liters)
Fluid End Material .....	Nickle plated Spheroidal Cast Iron	

Consult the factory for special requirements that must be met if the pump is to operate beyond one or more of the limits specified above.

<b>GP8065 HORSEPOWER REQUIREMENTS</b>					
RPM	GPM	500 PSI	750 PSI	1000 PSI	2000 PSI
300	54	19.3	28.9	38.6	77.1
400	72	25.7	38.6	51.4	102.9
500	91	32.5	48.8	65.0	130.0
580	105	37.5	56.3	75.0	150.0

**HORSEPOWER RATINGS:**

The rating shown are the power requirements for the pump. Gas engine power outputs must be approximately twice the pump power requirements shown above.

We recommend a 1.1 service factor be specified when selecting an electric motor as the power source. To compute specific pump horse power requirements, use the following formula:

$$\frac{\text{GPM} \times \text{PSI}}{1400} = \text{HP}$$

**SPECIAL NOTE:**

The theoretical gallons per revolution (gal/rev) is 0.181.  
To find specific outputs at various RPM, use the formula:

$$\text{GPM} = 0.181 \times \text{RPM}$$

# Exploded View - GP8050, GP8060, GP8065

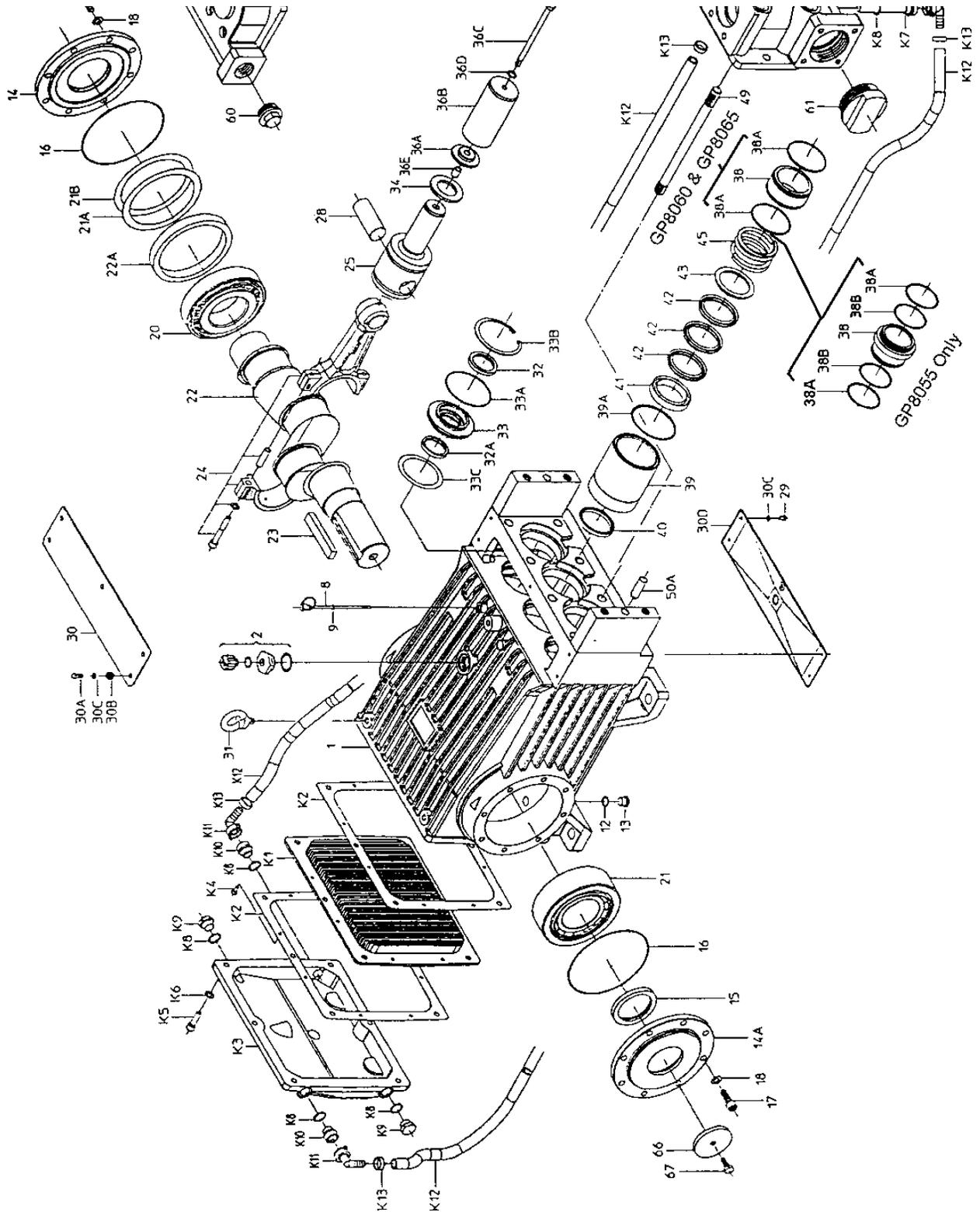

# Part List - GP8050, GP8060, GP8065

Item	Part	Description	Qty	Item	Part	Description	Qty
1	05024	Crankcase	1	41	05117	Pressure Ring (GP8065)	3
2	06912	Oil Filler Plug Assy with Vent	1	41	05068	Pressure Ring (GP8060)	3
8	05035	Oil Dipstick Assy	1	41	05276	Pressure Ring (GP8055)	3
9	06225	O-Ring	1	42	06997	V Sleeve (GP8065)	9
12	07109	Plug G1/2	2	42	05069	V Sleeve (GP8060)	9
13	07182	Seal	2	42	05277	V Sleeve (GP8055)	9
14	05036	Bearing Cover Closed	1	43	05118	Sleeve Support Ring (GP8065)	3
14A	05111	Bearing Cover Open	1	43	05070	Sleeve Support Ring (GP8060)	3
15	05112	Radial Shaft Seal	1	43	05278	Sleeve Support Ring (GP8055)	3
16	05037	O-Ring	2	45	05119	Seal Tension Spring (GP8065)	3
17	05038	Hexagon Socket Screw	16	45	05071	Seal Tension Spring (GP8060)	3
18	05039	Spring Ring	16	45	05279	Seal Tension Spring (GP8055)	3
19	05040	Clip Ring	1	49	05072	Stud Bolt	8
20	05041	Tapered Roller Bearing	1	49A	05073	Hexagon Nut	8
21	05044	Tapered Roller Bearing	1	50	05074	Valve Casing	1
21A	05042	Fitting Disc	5	50A	13162	Centering Stud	2
21B	05043	Fitting Disc	5	50B	05075	Discharge Casing	1
21C	05113	Fitting Disc	5	51	05076	Suction Valve Assy.	3
22	05045	Crankshaft (For Gearbox Pumps)	1	51A	05077	Spring Tension Cap	3
22	05114	Crankshaft	1	51B	05078	Suction Valve Seat	3
22A	05046	Spacer Ring	1	51C	05079	Valve Plate	3
23	05104	Fitting Key	1	51D	07658	O-Ring	3
24	05047	Conn-rod Assy	3	51E	05080	Valve Spring	3
25	05048	Crosshead c/w Plunger	3	51F	05081	Valve Spring Guide	3
28	05049	Crosshead Pin	3	52	05082	Discharge Valve Assy	3
29	05057	Hexagon Screw	5	52A	05077	Spring Tension Cap	3
30	05052	Cover Plate	1	52B	05084	Discharge Valve Seat	3
30A	07225-0100	Hexagon Screw	5	52C	05079	Valve Plate	3
30B	13136	Grommet	5	52D	06258	O-Ring	6
30C	05053	Washer	10	52E	05080	Valve Spring	3
30D	05050	Splash Cover	1	52F	05081	Valve Spring Guide	3
31	07623	Eye Bolt	3	56	05085	Discharge Valve Adaptor	3
32	05058	Radial Shaft Seal	3	56A	06258	O-Ring	3
32A	05057	Compact Ring	3	57	05086	Pressure Spring	3
33	05055	Seal Retainer	3	57A	06078	Pressure Spring	3
33A	05056	O-Ring	3	58	05087	Hexagon Socket Screw	12
33B	05054	Clip Ring	3	59	07109	Plug G1/2	1
33C	05059	Fitting Disc	3	59A	07661	Copper Seal	1
34	05060	Oil Shield	3	60	06909	Plug G1 1/4	1
36A	05063	Cover for Plunger Pipe (GP8060/GP8065)	3	61	05088	Plug G3	1
36B	05115	Plunger Pipe (GP8065)	3	62	06090	Plug G1/4	6
36B	05061	Plunger Pipe (GP8060)	3	62A	06934	Copper Gasket	6
36B	05280	Plunger Pipe (GP8055)	3	66	05122	Disc for Crankshaft	1
36C	05062	Tension Screw	3	67	13358	Hexagon Screw	1
36D	07665	Copper Washer	3	K1	05026	Cooling Vane Plate	1
36E	06900	Centering Sleeve	3	K2	05027	Seal for Gear Cover	2
38	05064	Seal Case (GP8060/GP8065)	3	K3	05028	Gear Cover	1
38	05283	Seal Case (GP8055)	3	K4	05029	Hexagon Head Countersunk Screw	8
38A	06667	O-Ring (GP8060/GP8065)	6	K5	07381	Hexagon Socket Screw	6
38A	13286	O-Ring (GP8055)	6	K6	08041	Washer	6
38B	05281	Support Ring (GP8055 Only)	6	K7	05030	Connection for Oil Cooler	1
39	05116	Seal Sleeve (GP8065)	3	K8	07661	Copper Seal	6
39	05065	Seal Sleeve (GP8060)	3	K9	07109	Plug G1/2	2
39	05275	Seal Sleeve (GP8055)	3	K10	05031	Connecting Branch	3
39A	05066	O-Ring	3	K11	05032	Hose Adaptor	4
40	06996	Seal Ring (GP8065)	3	K12	05033	Tube for Cooler	2
40	05067	Seal Ring (GP8060)	3	K13	05034	Hose Clamp	4
40	07723	Seal Ring (GP8055)	3				

## GP8055/GP8060/GP8065 PUMP REPAIR KITS

### Plunger Packing Kits

#### GP8055 - #09616

Item	Part #	Description	Qty.
38A	13286	O-Ring	6
38B	05281	Support Ring	6
39A	05066	O-Ring	6
40	07723	Seal Ring	3
42	05277	V-Sleeve	9

#### GP8060 - #09617

Item	Part #	Description	Qty.
38A	06667	O-Ring	6
39A	05066	O-Ring	6
40	05067	Seal Ring	3
42	05069	V-Sleeve	9

#### GP8065 - #09586

Item	Part #	Description	Qty.
38A	06667	O-Ring	6
39A	05066	O-Ring	6
40	06996	Seal Ring	3
42	06997	V-Sleeve	9

### Oil Seal Kit - #09221

Item	Part #	Description	Qty.
33A	05056	O-Ring	3
33B	05057	Compact Ring	3
33C	05058	Radial Shaft Seal	3

### Inlet Valve Kit - #09587

Item	Part #	Description	Qty.
53B	05078	Inlet Valve Seat	1
53C	05079	Valve Plate	1
53D	07658	O-Ring	1
53E	05080	Valve Spring	1
53F	05081	Valve Spring Guide	1

### Discharge Valve Kit - #09588

Item	Part #	Description	Qty.
54B	05084	Discharge Valve Seat	1
54C	05079	Valve Plate	1
54D	06258	O-Ring	1
54E	05080	Valve Spring	1
54F	05081	Valve Spring Guide	1

GP8055/GP8060/GP8065 TOOL LIST AND TORQUE SPECIFICATIONS				
ITEM	PART #	DESCRIPTION	TORQUE Ft-lbs (NM)	TOOL NEEDED
17	05038	Hexagon Socket Screw	64 (87)	10mm allen wrench
24	05047	Connecting Rod Hexagon Socket Screw	37 (50)	8mm allen wrench
33B	05054	Clip Ring	n/a	Industrial Snap ring pliers
36C	05062	Tension Screw	30 (40)	16mm socket
49A	05073	Hexagon Nut (manifold)	265 (360)	30mm socket
51/52	05084/05076	Valve Assemblies	n/a	Valve puller (p/n 07662) - included with pump
58	05087	Hexagon Socket Screw	132 (180)	12mm allen wrench
K5	07381	Hexagon Socket Screw	n/a	8mm allen wrench

GP8000 Trouble Shooting		
Problem	Cause	Solution
Pressure drops, water leaks	V-sleeves leak	Replace V-sleeves, examine surface of plunger
Pressure drops, pump becomes loud	Discharge or suction valve leaks	Replace valve
	Steam formation (cavitation)	Reduce suction height, reduce flow resistance in inlet line, clean inlet filter, lower water temperature
Irregular pressure	Worn valves	Examine valves
	O-Ring on the valves or inlet valve adapter leaks	Examine O-ring, examine valve casing for unevenness on the sealing surfaces
Oil leaks at visible part of plunger	Gear sealing is leaky	Examine seals and running surface of plunger
Dirty mil-colored frothy oil	Oil has mixed with water	Replace oil immediately, find and fix the cause
Oil leakage on the crankshaft	Shaft seal ring leaks	Check seal and shaft
Noise increases without loss of pressure	Worn bearing	Dismantle gear, examine all parts, replace worn parts, check oil level. If service life was too short, check for excess strain or whether lubrication intervals were too long. Only specified lubricants are to be used

## GP8055/GP8060/GP8065 PUMP REPAIR INSTRUCTIONS

# Valve Inspection and Repair

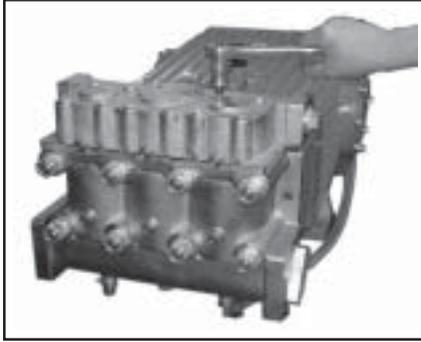

1) Remove bolts (58).



2) Remove discharge casing (50B) up and away.



3) Take out pressure springs (57A). Pull out assembled valves (51 & 52) with fitting tool.

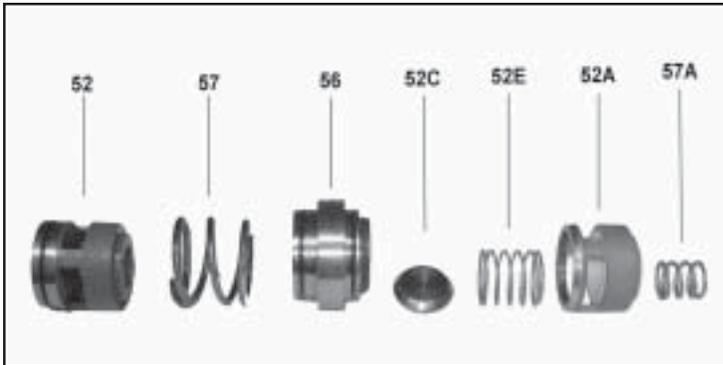

4) The spring tension cap (51A, 52A) is screwed together with the valve seat (51B or 52B). Screw off spring tension cap. Takeout springs (51E, 52E) and valve plate (51C, 52C). Check sealing surfaces and O-rings (51D, 52D). Replace worn parts. Coat threads of valve seat with silicon grease or molycote anti-seize Cu-7439 when reassembling. Before refitting the valves, clean the sealing surfaces in the casing and check for any damage. Tighten caps (58) at 133 Ft-lbs; check torque tension after 8-10 operating hours.

# To Check Seals and Plunger Pipe

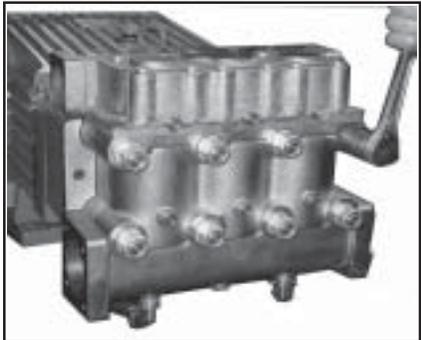

5) Remove hexagon nuts (49A) and valve casing together with seal case (38) from crankcase (1). If necessary, carefully tap the valve casing (50) past the centering stud (50A) using a rubber hammer.

**IMPORTANT!** If necessary, support the valve casing by resting it on wooden blocks or by using a pulley.

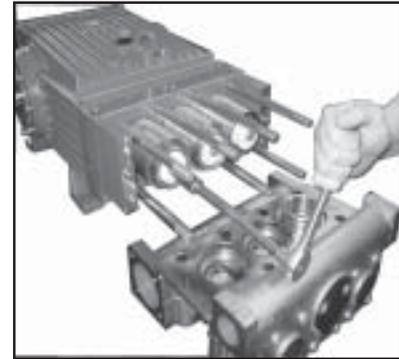

6) Remove tension screw (36C) and take seal sleeve (39) together with all mounted parts out of the drive. Pull plunger pipe out of the seal assembly and check for any damage. Carefully, remove seal rings (40) and sleeves (42) with a screw driver.

## GP8055/GP8060/GP8065 PUMP REPAIR INSTRUCTIONS

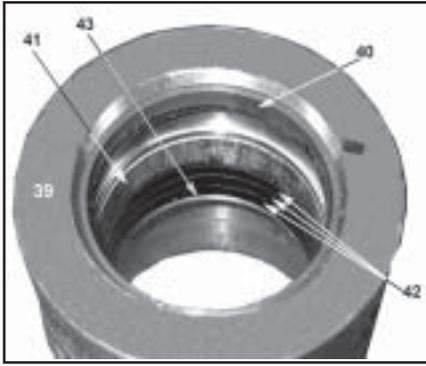

7) **Important!** Be careful not to damage the seal sleeve (39) and pressure ring (41). Check the inner diameter of the pressure ring for wear and if necessary replace together with seals (40) and (42). Clean all parts. New parts should be lightly coated with silicon grease before installation. Inert the seal unit (40, 41, 42 43) into the sleeve. Push the ceramic plunger carefully through the seals from the crankcase side. If necessary, the seals can be held tightly using a suitable pipe support held on the other side of the seal sleeve.

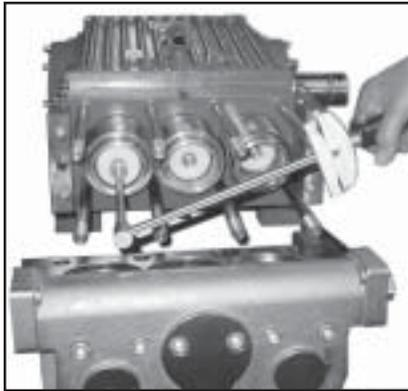

8) Coat the seal sleeve lightly with anti-corrosive grease (e.g. molycote no. Cu-7439) in its fitted area towards the crankcase. Insert the seal sleeves in to their crankcase fittings. Coat the threads of the tension screw (36C) lightly with thread glue and insert it together with a new copper ring (36D) through the ceramic pipe. Turn the pump per hand until the plunger (25) rests against the plunger pipe. Tighten the tension screw at 30 Ft.-lbs.

**Important!** Thread glue must never come between the plunger pipe (36B) and centering sleeve (36E). Overtensioning of the plunger pipe by excessive tightening of the tension screw and/or dirt or damage on the mounting surfaces can lead to plunger pipe breakage. Insert the seal tension spring (45) and O-ring (39A) in to the seal sleeve (39).

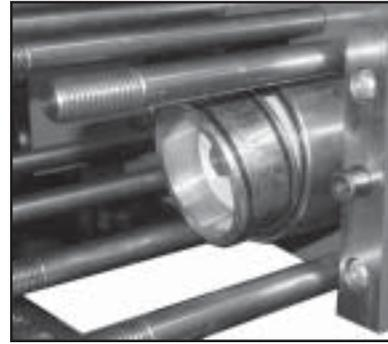

8) Take out the seal case (38) from the valve (if necessary secure 2 screwdrivers in the front O-ring groove to extract seal casing from valve casing). Coat seals with silicon grease before installing.

**Important!** Mounting surfaces of the crankcase and the valve casing must be clean and free of damage. The components must lie exactly and evenly on one another. The same exactness applies for all centering positions in the crankcase, pressure and valve casing.

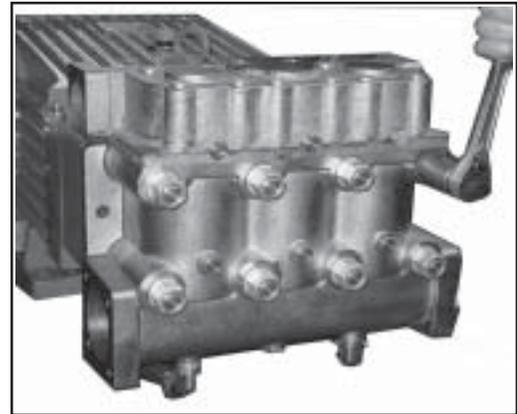

### Replacing Valve Casing:

9) Put seal cases (38) in the centering holes of the valve casing, then push valve casing carefully on to centering studs (50A). Tighten hexagon screws (49A) evenly and crosswise at 266 Ft.-lbs.

**Important!** The torque tension on the screws (49A) must be checked after 8-10 operating hours; the pump must be at zero pressure. Thereafter, the tension is to be checked every 200 operating hours.

# GP8055/GP8060/GP8065 PUMP REPAIR INSTRUCTIONS

## To Dismantle Crankcase Gear

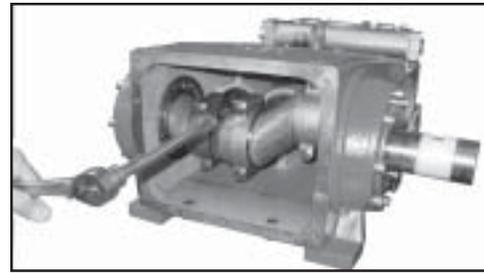
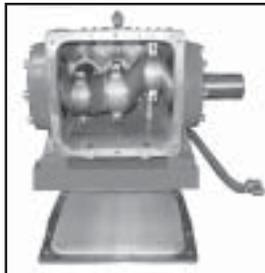

10) Take out plungers and seal sleeves as described above. Drain the oil by taking off the plug (12). After removing the clip ring (33B), lever out the seal retainer (33) with a screwdriver. Open hose adaptor (K11) and remove gear cover (K3). Remove the cooling vane plate (K1) by removing the screws (K4)

11) Remove the connecting rod screws (24).

**Important!!** Connecting rods are marked 1 to 3 for identification. Do not twist connecting rod halves or interchange them. When reassembling, the connecting rod must be fitted in their exact original position on the crankshaft journals.

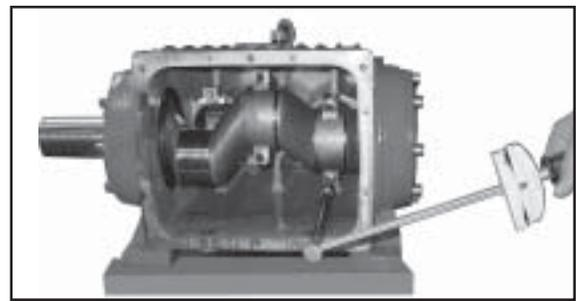
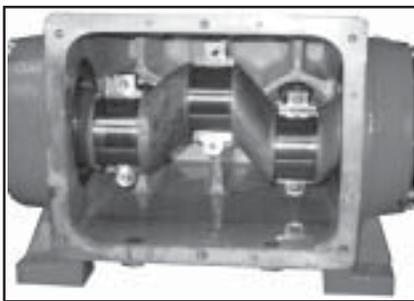

12) Push connecting rod halves together with the crosshead as far as possible into the crosshead guide. Take out bearing cover (14/14A) and push out crankshaft taking particular care that the con rod doesn't get bent. Check surfaces on the connecting rods (24), crankshaft (22) and crossheads (25). Check the surfaces of the crosshead guides in the crankcase for any unevenness.

13) Reassemble in reverse order. Thread the long end of the crankshaft together with the inner bearing rings into the crankcase; then mount outer bearing ring (20) and spacer ring (22A). Mount connecting rod halves in their exact original position and tighten at 37 Ft-lbs.

**Important!!** Connecting rods must be able to move slightly sideways on the stroke journals.

14) Mount bearing cover (14A) and tighten screws (17) to 64 Ft-lbs. Adjust axial play (clearance) on the crankshaft to minimum 0.1 mm / max. 0.15 mm using shims (21A/21B). The shaft should turn easily with little clearance. Connecting rod must sit exactly in the middle of each crank pin. Fit the bearing cover (14) and tighten the screws (17) at 64 Ft-lbs. Seal (32A) must always be installed so that the seal lip on the inside diameter faces the oil. Possible axial float of the seal adaptor (33) to be compensated with shims (33C).

Mount cooling plate (K1) and gear cover (K3) with their respective seals (K2). When assembling the cooling circuit line, make sure that the oil cooler connection (K7) is always joined to the upper connection (K3) of the gear cover.

## GP8050, GP8060, GP8065 SERIES DIMENSIONS - (mm)

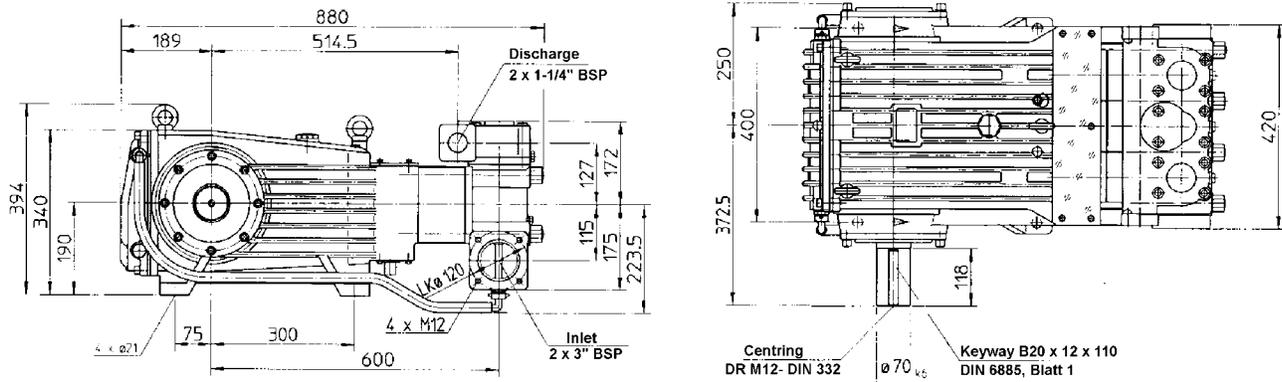

### GIANT INDUSTRIES LIMITED WARRANTY

Giant Industries, Inc. pumps and accessories are warranted by the manufacturer to be free from defects in workmanship and material as follows:

1. For portable pressure washers and self-service car wash applications, the discharge manifolds will never fail, period. If they ever fail, we will replace them free of charge. Our other pump parts, used in portable pressure washers and in car wash applications, are warranted for five years from the date of shipment for all pumps used in NON-SALINE, clean water applications.
2. One (1) year from the date of shipment for all other Giant industrial and consumer pumps.
3. Six (6) months from the date of shipment for all rebuilt pumps.
4. Ninety (90) days from the date of shipment for all Giant accessories.

This warranty is limited to repair or replacement of pumps and accessories of which the manufacturer's evaluation shows were defective at the time of shipment by the manufacturer. The following items are NOT covered or will void the warranty:

1. Defects caused by negligence or fault of the buyer or third party.
2. Normal wear and tear to standard wear parts.
3. Use of repair parts other than those manufactured or authorized by Giant.
4. Improper use of the product as a component part.
5. Changes or modifications made by the customer or third party.
6. The operation of pumps and or accessories exceeding the specifications set forth in the Operations Manuals provided by Giant Industries, Inc.

Liability under this warranty is on all non-wear parts and limited to the replacement or repair of those products returned freight prepaid to Giant Industries which are deemed to be defective due to workmanship or failure of material. A Returned Goods Authorization (R.G.A.) number and completed warranty evaluation form is required prior to the return to Giant Industries of all products under warranty consideration. Call (419)-531-4600 or fax (419)-531-6836 to obtain an R.G.A. number.

Repair or replacement of defective products as provided is the sole and exclusive remedy provided hereunder and the MANUFACTURER SHALL NOT BE LIABLE FOR FURTHER LOSS, DAMAGES, OR EXPENSES, INCLUDING INCIDENTAL AND CONSEQUENTIAL DAMAGES DIRECTLY OR INDIRECTLY ARISING FROM THE SALE OR USE OF THIS PRODUCT.

THE LIMITED WARRANTY SET FORTH HEREIN IS IN LIEU OF ALL OTHER WARRANTIES OR REPRESENTATION, EXPRESS OR IMPLIED, INCLUDING WITHOUT LIMITATION ANY WARRANTIES OR MERCHANTABILITY OR FITNESS FOR A PARTICULAR PURPOSE AND ALL SUCH WARRANTIES ARE HEREBY DISCLAIMED AND EXCLUDED BY THE MANUFACTURER.



#### GIANT INDUSTRIES, INC.

900 N. Westwood Ave.

P.O. Box 3187

Toledo, Ohio 43607

(419) 531-4600

FAX (419) 531-6836

www.giantpumps.com

© Copyright 2007 Giant Industries, Inc.