



*GE Industrial Systems*

---

# *AV-300i*™

## Quick Start Up Guide

This book is referred to SW version 1.X00

This book replaces the Instruction Book Rev. 1.0c (09/98)

These instructions do not purport to cover all details or variations in equipment, nor to provide every possible contingency to be met during installation, operation, and maintenance. If further information is desired or if particular problems arise that are not covered sufficiently for the purchaser's purpose, the matter should be referred to GE Industrial Systems.

This document contains proprietary information of General Electric Company, USA and is furnished to its customer solely to assist that customer in the installation, testing, operation, and/or maintenance of the equipment described. This document shall not be reproduced in whole or in part nor shall its contents be disclosed to any third party without the written approval of GE Industrial Systems.

**© 1999 by General Electric Company, USA. All rights reserved.**

# Table of Contents

- 1. Safety Precautions - Precautions de sécurité ..... 4**  
 Functional connection diagram ..... 7
- 2. Overview ..... 8**
- 3. Control Terminals ..... 9**  
 3.1 Maximum cable cross section for regulator terminals ..... 10
- 4. Power terminals ..... 10**  
 4.1 Maximum cable cross section for power terminals ..... 10
- 5. Encoder terminals (XE connector) ..... 11**  
 5.1 Encoder type connection ..... 11  
 5.2 JUMPERS setting ..... 12  
     List of jumpers and dip-switch ..... 12  
     List of dip-switch ..... 13  
 5.3 Maximum cable length for encoder terminals ..... 13
- 6. Keypad operation ..... 14**  
 Keypads (on right the optional LED module) ..... 14  
 LEDs ..... 15  
 Moving inside a menu ..... 16
- 7. Pre Power Checks ..... 17**
- 8. Quick tuning ..... 18**
- 9. Options ..... 22**
- 10. Quick Tuning Guide for Factory Configured Drives ..... 22**
- 11. Troubleshooting ..... 23**  
 Overflow list ..... 23  
 List of Self-tuning Errpr Messages ..... 24  
 Failure alarms in the keypad display ..... 25  
 Other faults ..... 27

# 1. Safety Precautions - Precautions de sécurité

## **WARNING/ATTENTION!**

According to the EEC standards the AV300i should be used only after checking that the mechanical equipment uses safety devices required by the 89/392/EEC set of rules.

Drive systems cause mechanical motion. It is the responsibility of the user to insure that any such motion does not result in an unsafe condition. Factory provided interlocks and operating limits should not be bypassed or modified.

*Selon les normes EEC, les drives AV300i et leurs accessoires doivent être employés seulement après avoir vérifié que la machine ait été produite avec les mêmes dispositifs de sécurité demandés par la réglementation 89/392/EEC concernant le secteur de l'industrie.*

*Les systèmes provoquent des mouvements mécaniques. L'utilisateur est responsable de la sécurité concernant les mouvements mécaniques. Les dispositifs de sécurité prévues par l'usine et les limitations opérationnelles ne doivent être dépassés ou modifiés.*

## **WARNING - ELECTRICAL SHOCK AND BURN HAZARD / ATTENTION – DÉCHARGE ÉLECTRIQUE ET RISQUE DE BRÛLURE :**

When using instruments such as oscilloscopes to work on live equipment, the oscilloscope's chassis should be grounded and a differential input amplifier should be used. Care should be used in the selection of probes and leads so that accurate readings may be made. See the instrument manufacturer's instruction book for proper operation and adjustments of the oscilloscope.

*Lors de l'utilisation d'instruments (par exemple oscilloscope) sur des systèmes en marche, le châssis de l'oscilloscope doit être relié à la terre et un amplificateur différentiel devrait être utilisé en entrée.*

*Les sondes et conducteurs doivent être choisis avec soin pour effectuer les meilleures mesures à l'aide d'un oscilloscope. Voir le manuel d'instruction pour une utilisation correcte des instruments.*

## **WARNING - FIRE AND EXPLOSION HAZARD / ATTENTION – RISQUE D'INCENDIES ET D'EXPLOSIONS:**

Fires or explosions might result from mounting drives in hazardous areas such as locations where flammable or combustible vapors are present. Drives should be installed away from hazardous areas, even if used with motors suitable for use in these locations.

*L'utilisation des drives dans des zones à risques (présence de vapeurs ou de poussières inflammables), peut provoquer des incendies ou des explosions. Les drives doivent être installés loin des zones dangereuses, et équipés de moteurs appropriés.*

## **WARNING - STRAIN HAZARD / ATTENTION À L'ÉLÉVATION:**

Improper lifting practices can cause serious or fatal injury. Lift only with adequate equipment and trained personnel.

*Une élévation inappropriée peut causer des dommages sérieux ou fatals. Il doit être élevé seulement avec des moyens appropriés et par du personnel qualifié.*

## **WARNING - ELECTRICAL SHOCK / ATTENTION – CAS DE DÉCHARGE ÉLECTRIQUE:**

Drives and motors must be grounded according to NEC.

*Tous les moteurs et les drives doivent être mis à la terre selon le Code Electrique National ou équivalent.*

## **WARNING / ATTENTION:**

Replace all covers before applying power to the drive. Failure to do so may result in death or serious injury.

*Remettre tous les capots avant de mettre sous tension le drive. Des erreurs peuvent provoquer de sérieux accidents ou même la mort.*

## **WARNING / ATTENTION:**

Adjustable frequency drives are electrical apparatus for use in industrial installations. Parts of the drives are energized during operation. The electrical installation, tune-up and troubleshooting should therefore only be carried out by qualified personnel. Improper installation of motors or drives may cause the failure of the drive as well as serious injury to persons or equipment. The drive is not equipped with motor overspeed protection logic.

Follow the instructions given in this manual and observe the local and national safety regulations applicable.

*Les drives à fréquence variable sont des dispositifs électriques utilisés dans des installations industriels. Une partie des drives sont sous tension pendant l'opération. L'installation électrique et l'ouverture des drives devrait être exécuté uniquement par du personnel qualifié. De mauvaises installations de moteurs ou de drives peuvent provoquer des dommages matériels ou blesser des personnes.*

*Le convertisseur n'est pas pourvu de protection contre vitesse de fuite du moteur. On doit suivre les instructions données dans ce manuel et observer les règles nationales de sécurité.*

## **CAUTION / PRECAUTION:**

Do not connect power supply voltages that exceeds the standard specification. If excessive voltage is applied to the drive, damage to the internal components will result.

*Ne pas raccorder de tension d'alimentation dépassant la fluctuation de tension permise par les normes. Dans le cas d'une alimentation en tension excessive, des composants internes peuvent être endommagés.*

**CAUTION / PRECAUTION:**

Do not operate the drive without a ground wire being connected. The motor chassis should be grounded to earth through a ground lead separate from all other equipment ground leads to prevent noise coupling.

The grounding connector shall be sized in accordance with the NEC or Canadian Electrical Code. The connection shall be made by a UL listed or CSA certified closed-loop terminal connector sized for the wire gauge involved. The connector must be attached to the wire using the crimp tool specified by the terminal manufacturer.

*Ne pas faire fonctionner le drive sans prise de terre. Le châssis du moteur doit être mis à la terre à l'aide d'un connecteur de terre séparé des autres pour éviter le couplage des perturbations. Le connecteur de terre devrait être dimensionné selon la norme NEC ou le Canadian Electrical code. Le raccordement devrait être fait par un connecteur certifié et mentionné à boucle fermée par les normes CSA et UL et dimensionné pour l'épaisseur du câble correspondant. Le connecteur doit être fixé à l'aide d'un instrument de serrage spécifié par le producteur du connecteur.*

**CAUTION / PRECAUTION:**

Do not perform a megger test between the drive terminals or the control circuit terminals.

Ne pas exécuter un test megger entre les bornes du drive ou entre les bornes du circuit de contrôle.

**CAUTION / PRECAUTION:**

Because the ambient temperature greatly effects drive life and reliability, do not install the drive in any location that exceeds the allowable temperature. Leave the ventilation cover attached for temperatures of 104° F (40° C) or below.

*Étant donné que la température ambiante influe sur la vie et la fiabilité du drive, on ne devrait pas installer le drive dans des places où la température permise est dépassée. Laisser le capot de ventilation en place pour températures de 104°F (40°C) ou inférieures.*

**CAUTION / PRECAUTION:**

If the drive's Fault Alarm is activated, consult the TROUBLESHOOTING section of this instruction book. Correct the problem before resuming operation, automatic reset of faults is **not** recommended.

*Si la Fault Alarm du drive est activée, consulter la section du manuel concernant les défauts et après avoir corrigé l'erreur, reprendre l'opération. Ne pas réinitialiser l'alarme automatiquement par une séquence externe, etc....*

**CAUTION / PRECAUTION:**

Be sure to remove the desiccant dryer packet(s) when unpacking the drive. (If not removed these packets may become lodged in the fan or air passages and cause the drive to overheat).

*Lors du déballage du drive, retirer le sachet déshydraté. (Si celui-ci n'est pas retiré, il empêche la ventilation et provoque une surchauffe du drive).*

**CAUTION / PRECAUTION:**

The drive must be mounted on a wall that is constructed of heat resistant material. While the drive is operating, the temperature of the drive's cooling fins can rise to a temperature of 194° F (90° C).

*Le drive doit être monté sur un mur construit avec des matériaux résistants à la chaleur. Pendant le fonctionnement du drive, la température des ailettes du dissipateur thermique peut arriver à 194°F (90°).*

**Note:**

The terms "inverter", "controller" and "drive" are sometimes used interchangeably throughout the industry. We will use the term "drive" in this document

*Les mots "inverter", "controller" et "drive" sont interchangeables dans le domaine industriel. Nous utiliserons dans ce manuel seulement le mot "drive".*

1. Never open the device or covers while the AC Input power supply is switched on. Minimum time to wait before working on the terminals or inside the drive is listed in section 4.11 in the Instruction manual .

*Ne jamais ouvrir l'appareil lorsqu'il est sous tension. Le temps minimum d'attente avant de pouvoir travailler sur les bornes ou bien à l'intérieur de l'appareil est indiqué dans la section 4.11 (Instruction manual).*

2. Be careful not to the damage any components when handling the drive. Changing of the isolation gaps or removing the insulation or covers is not permissible. If the front cover has to be removed because of a room temperature, higher than 40°C, the user has to ensure that no occasional contact with live parts may occur.

*Manipuler l'appareil de façon à ne pas toucher ou endommager des parties. Il n'est pas permis de changer les distances d'isolement ou bien d'enlever des matériaux isolants ou des capots. Si la plaque frontale doit être enlevée pour un fonctionnement avec la température de l'environnement plus haute que 40°C, l'utilisateur doit s'assurer, par des moyens opportuns, qu'aucun contact occasionnel ne puisse arriver avec les parties sous tension.*

3. Protect the drive from extreme environmental conditions (temperature, humidity, shock etc.)

*Protéger l'appareil contre des effets extérieurs non permis (température, humidité, chocs etc.).*

4. No voltage should be connected to the output of the frequency inverter (terminals U2, V2 W2). The parallel connection of several drives via outputs nor the direct connection of inputs and outputs (bypass) are not permissible.

*Aucune tension ne doit être appliquée sur la sortie du convertisseur (bornes U2, V2 et W2). Il n'est pas permis de raccorder la sortie de plusieurs convertisseurs en parallèle, ni d'effectuer une connexion directe de l'entrée avec la sortie du convertisseur (Bypass).*

5. When engaging a running motor, the Auto capture function (Auto capture in the ADD SPEED FUNCT menu) must be activated (not applicable to **Regulation mode**=sensorless vect).

*Pour reprendre des moteurs en rotation, la fonction suivante doit être activée : "Auto capture" dans le menu ADD SPEED FUNCT.*

- A capacitive load (e.g. variable power factor capacitors) should not be connected to the output of the drive (terminals U2, V2, W2).

*Aucune charge capacitive ne doit être connectée à la sortie du convertisseur (bornes U2, V2 et W2) (par exemple des condensateurs de mise en phase).*

- Always connect the drive to the protective ground (PE) via the marked connection terminals (PE2) and the housing (PE1). Adjustable Frequency Drives and AC Input filters have ground discharge currents greater than 3.5 mA. EN 50178 specifies that with discharge currents greater than 3.5 mA the protective conductor ground connection (PE1) must be a fixed type and doubled for redundancy.

*Effectuer toujours des connexions de terre (PE) par le biais des bornes (PE2) et du châssis (PE1). Le courant de dispersion vers la terre est supérieur à 3,5 mA. Selon EN 50178 il faut prévoir dans ces cas une double connexion à terre.*

- The electrical commissioning should only be carried out by qualified personnel, who are also responsible for a suitable ground connection. The power supply feeder must be in accordance with the local and national regulations. The motor must be protected against overloads.

*La mise en service électrique doit être effectuée par un personnel qualifié. Ce dernier est responsable de l'existence d'une connexion de terre adéquate et d'une protection des câbles d'alimentation selon les prescriptions locales et nationales. Le moteur doit être protégé contre la surcharge*

- No dielectric tests should be carried out on parts of the drive. A suitable measuring instrument (internal resistance of at least 10 k $\Omega$ /V) should be used for measuring the signal voltages.

*Il ne faut pas exécuter de tests de rigidité diélectrique sur des parties du convertisseurs. Pour mesurer les tensions, des signaux, il faut utiliser des instruments de mesure appropriés (résistance interne minimale 10 k $\Omega$ /V).*

- If the drives have been stored for longer than three years, the operation of the DC link capacitors may be impaired. Therefore, before commissioning, connect them to a power supply for two hours with no load connected in order to regenerate the capacitors (the input voltage has to be applied without enabling the drive).

*En cas de stockage des convertisseurs pendant plus de trois ans, il faut tenir compte du fait que les condensateurs du circuit intermédiaire gardent leurs caractéristiques d'origine seulement s'ils sont alimentés avant trois ans, à partir de leur date de fabrication. Avant la mise en service des appareils, qui sont restés stockés aussi longtemps, il est conseillé d'alimenter les convertisseurs pendant au moins deux heures, pour récupérer les caractéristiques d'origine des condensateurs : appliquer une tension d'entrée sans activer le convertisseur (**Disable**).*

- The drive may start accidentally because of a failure, even if disabled, unless it has been disconnected from the AC input feeder.

*L'appareil peut redémarrer de façon accidentel en cas d'anomalie, sauf s'il a été déconnecté du réseau.*

# Functional connection diagram

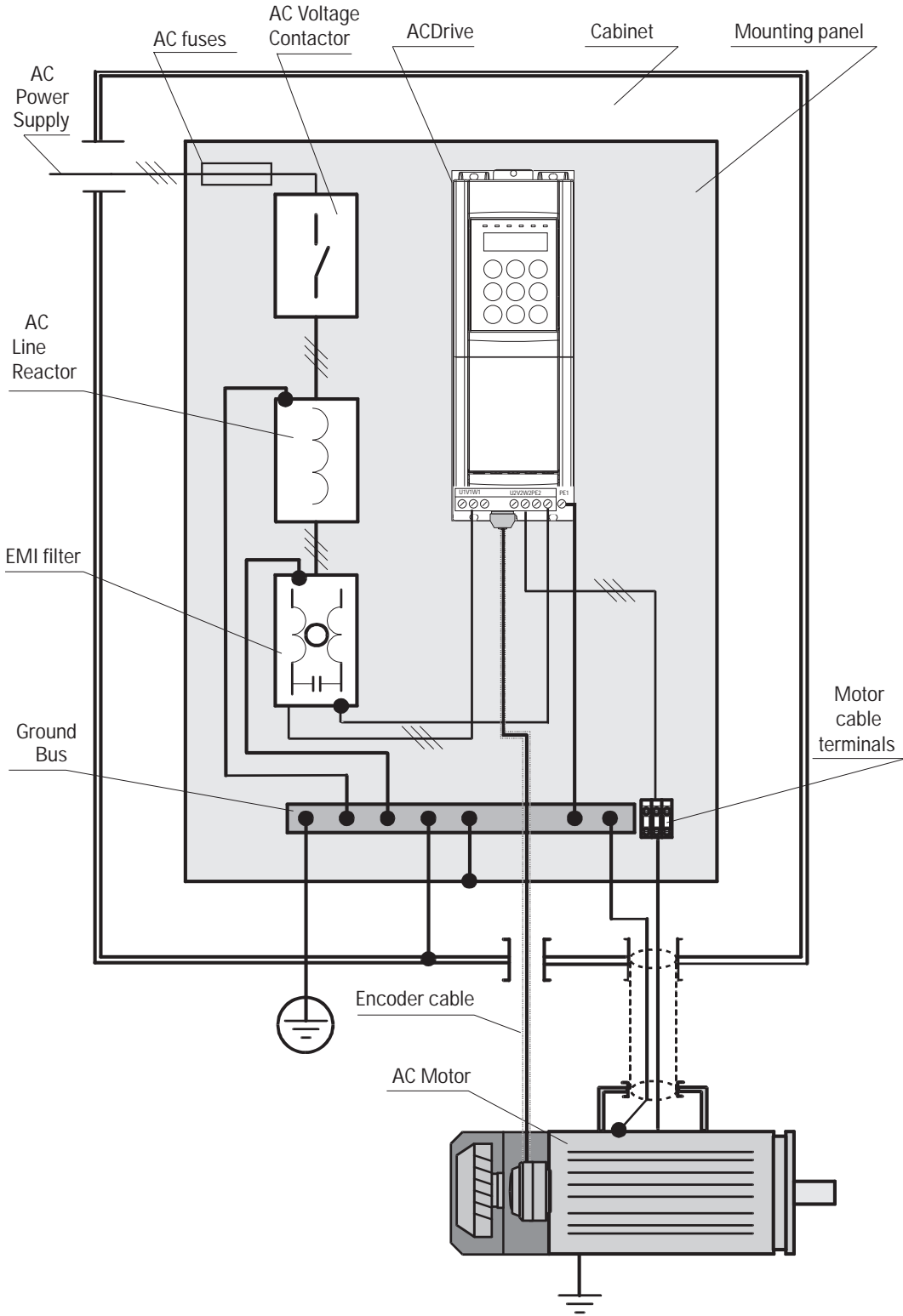

**Note:**

PE1 is the drive safety ground. If PE2 is used to connect the motor ground, EMC filter ground must be connected to PE1.



## 2. Overview

This guide assumes a standard start up using the keypad for a drive and motor that is to be run in either sensorless vector or flux vector (with digital or sinusoidal encoder) mode. It is also assumed that a standard scheme is to be used for control. In other words, that the drive will be run from pushbuttons (or contacts) and the speed will be set from a pot input (or a 0 to 10 VDC source). While the drive has more modes of operation, this guide will cover most applications. The manual can be used to help adjust more complicated configurations.

**Standard Wiring:** see the manual for the standard wiring configuration. Note that if this is a system designed and wired by our factory, the set up of the drive (aside from minor tuning) has already been done.

### NOTE:

**Memory:** There are two memories for set-up parameters. One is the active memory which is always the one currently in use by the drive. The other is the permanent memory which is the one the drive will use if power is lost and then restored. Note: power up is the ONLY time when the drive looks at permanent memory. All file uploads and downloads, all changes, etc. are made only to the active memory and read from the active memory. The only time permanent memory is used in any way is when it is booted into active memory on power up, and when it is changed to new values by the "Save Parameters" command. When parameters are changed during set-up, the drive will use those parameters but unless the "SAVE PARAMETERS" command is used these changes will not be permanent. This is an advantage if you are "trying" something to see how it works and don't intend to change your permanent set-up.

**Underline:** When words are underlined, they refer to a key on the keypad.

**Quotes:** Quote marks are put around words which will be seen in the display window of the keypad.

**Menu Navigation:** In the instructions, you will be directed to press keys to get to certain menu items. In many cases, the same key will have to be pressed more than once to get to a value. Note that the display has two lines, the top line always shows the next HIGHER level of the menu. All of the menu items referred to in this start up will be shown in the SECOND LINE of the display. The display on the top line is for information only and has nothing to do with entering data. If the instructions say to press the **[Down arrow]** to "Regulation Mode" it means keep pushing the **[Down arrow]** until the "Regulation Mode" is displayed in the second line. If you get confused, refer to the manual as it shows the complete menu structure.

**I/O Connections:** the drive WILL NOT OPERATE unless the hardware enable (I/O terminal 12) and the other interlocks are made. It is suggested to make things simple, to temporarily connect the terminal board inputs as follows:

Jumper 16 to 18, jumper 19 to 15, jumper 15 to 14, jumper 12 to 13, and connect a simple switch between 13 and 14. Turning the switch on and off will now enable and disable the drive (and start and stop it at the same time). If you have control over the I/O with the connected logic and can make the same connections with pushbuttons/contacts, the drive can be enabled with those.



### 3. Control Terminals

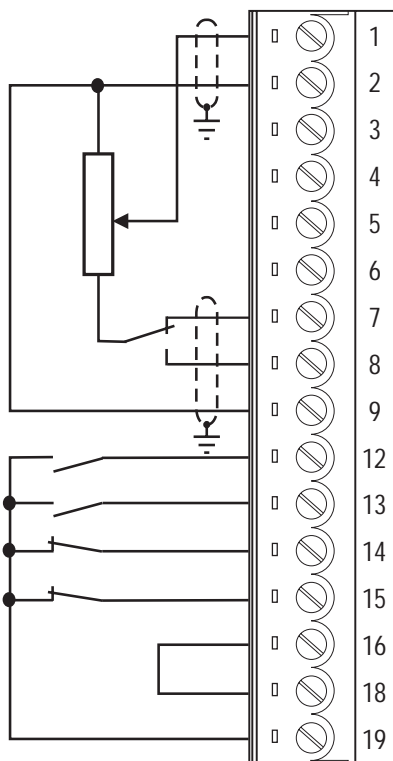

Strip X1	Function	max
Analog input 1	Programmable / configurable analog differential input. Signal: terminal 1. Reference point: terminal 2. Default setting: Ramp ref 1	±10V @ 0.25mA  (20 mA when current ref input)
Analog input 2	Programmable / configurable analog differential input. Signal: terminal 3. Reference point: terminal 4. Default setting: none	
Analog input 3	Programmable / configurable analog differential input. Signal: terminal 5. Reference point: terminal 6. Default setting: none. (1)	
+10VDC	Reference voltage +10V; Reference point: terminal 9	+10V/10 mA
-10VDC	Reference voltage -10V; Reference point: terminal 9	-10V/10 mA
0V	Internal 0V and reference point for ± 10V	-
Enable drive	Drive enable: 0V or open: drive disabled; +15...+30V: Drive enabled	+30V
Start	Drive start command: 0V or open: No start; +15...+30V: Start	3.2 mA@15V
Fast stop	OV or open: Fast stop. +15...+30V: No Fast stop.	5 mA@24V
External fault	OV or open: External fault. +15...+30V: No External fault	6.4 mA@30V
COMD I/O	Reference point for digital inputs and outputs, term.12...15, 36...39, 41...42	-
0V24	Reference point for +24V OUT supply, terminal 19	-
+24VDC	+24V supply output. Reference points: terminals 18 or 27 or 28	+22...28V 120 mA@24V

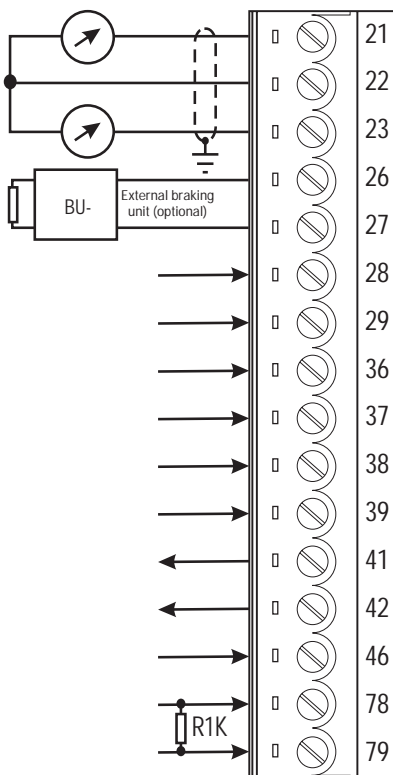

Analog output 1	Program. analog output; def. setting: Motor speed. Ref. point: term. 22	±10V/5 mA
0V	Internal 0V and reference point for terminals 21 and 23	-
Analog output 2	Program. analog output; def. setting: Motor current. Ref. point: term. 22	±10V/5 mA
BU comm. output	VeCon controlled BU... braking units command. Ref. point: term. 27.	+28V/15 mA
0V24	Reference point for BU...command ,terminal 26	-
RESERVED		-
RESERVED		
Digital input1	Programmable digital input; default setting: none	+30V
Digital input2		3.2 mA@15V
Digital input3		5 mA@24V
Digital input4		6.4 mA@30V
Digital output 1	Programmable digital output; default setting: none	+30V/40 mA
Digital output 2		
Supply DO	Supply input for digital outputs on terminals 41/42. Ref. point: term.16.	+30V/80 mA
Motor PTC	Motor PTC sensing for overtemperature (cutoff R1k if used)	1.5mA

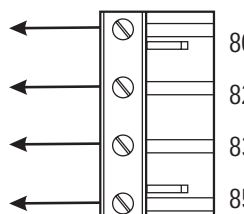

Strip X2	Function	max curr.
OK relay contact	Potential-relay contact OK relay (closed=OK)	250VAC 1A, AC11
Relay 2 contact	Potential-relay contact configurable (relay2). Default: open 0 drive stopped	250VAC 1A, AC11

### 3.1 Maximum cable cross section for regulator terminals

Terminals	Maximum Permissible Cable Cross-Section			Tightening torque [Nm]
	[mm <sup>2</sup> ]		AWG	
	flexible	multi-core		
1...79	0.14...1.5	0.14...1.5	28...16	0.4
80...85	0.14...1.5	0.14...1.5	28...16	0.4

AI4090

**NOTE:**

Terminal board points are intended for 1 wire/point.

Daisy chains and multiple wires/point are better done with a panel mounted terminal board.

### 4. power terminals

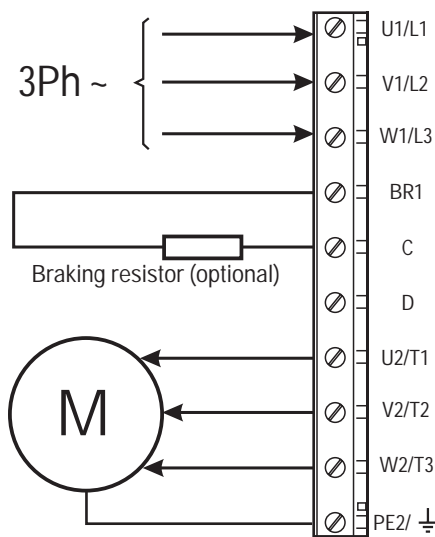

Function	max volts/curr.
AC line voltage	480 VAC +10% 3Ph See table 2.4.2.1
Braking unit resistor command (braking resistor must be connected between BR1 and C)	
DC Bus circuit connection	770 VDC/ 1.65 X output current
Motor connection	AC line volt 3Ph 1.36 X output current
Motor ground connection	



PE1/ PE2 Grounding (protective earth) conductor

#### 4.1 Maximum cable cross section for power terminals

Hp		3/4	1	2	3	5	7.5	10	15	20	25	30
U1, V1, W1, U2, V2, W2, C, D terminals	AWG	14			12	10		8	6		4	
	[mm <sup>2</sup> ]	2			4		8	10	16	25		
Tightening torque	[Nm]	0.5 to 0.6						1.2x1.5		2	3	
PE1, PE2 terminals	AWG	14			12	10		8	6		6	
	[mm <sup>2</sup> ]	2			4		8	10	16	16		
Tightening torque	[Nm]	0.5 to 0.6						1.2x1.5		2	3	

Hp		40	50	60	75	100	125	150	200
U1, V1, W1, U2, V2, W2, C, D terminals	AWG	2	1/0	2/0	4/0	300*	350*	4xA WG2	
	[mm <sup>2</sup> ]	35	50	70	95	150	185	4x35	
Tightening torque	[Nm]	4		12		10-30			
PE1, PE2 terminals	AWG	6		2					
	[mm <sup>2</sup> ]	16		50					
Tightening torque	[Nm]	3	4						

\*=kcmils

ai4040

## 5. Encoder terminals (XE connector)

Designation	F unction	I/O	max.voltage	max.current
PIN1	Channel B - For B- digital or B -COS incremental signal	I	5V digital or 1V pp analog	10 mA digital or 8.3 mA analog
PIN2	-			
PIN3	Channel C+ For C+ digital or analog zero pulse or index	I	5V digital or 1V pp analog	10 mA digital or 8.3 mA analog
PIN4	Channel C- For C-digital or analog zero pulse or index	I	5V digital or 1V pp analog	10 mA digital or 8.3 mA analog
PIN5	Channel A+ For A+ digital or A+SIN incremental signal	I	5V digital or 1V pp analog	10 mA digital or 8.3 mA analog
PIN6	Channel A - For A+ digital or A+SIN incremental signal	I	5V digital or 1V pp analog	10 mA digital or 8.3 mA analog
PIN7	Reference point for +5V encoder supply voltage	O	-	-
PIN8	Channel B+ For B+ digital or B+COS incremental signal	I	5V digital or 1V pp analog	10 mA digital or 8.3 mA analog
PIN9	+5V encoder supply voltage	O	+5V	200 mA
PIN10	Channel E+ For E+ digital commutation or SIN+ absolute position signal	I	5V digital or 1V pp analog	10 mA digital or 8.3 mA analog
PIN11	Channel E- For E- digital commutation or SIN- absolute position signal	I	5V digital or 1V pp analog	10 mA digital or 8.3 mA analog
PIN12	Channel F+ For F+ digital commutation or COS+ absolute position signal	I	5V digital or 1V pp analog	10 mA digital or 8.3 mA analog
PIN13	Channel F- For F- digital commutation or COS- absolute position signal	I	5V digital or 1V pp analog	10 mA digital or 8.3 mA analog
PIN14	Channel G+ For G+ digital commutation signal	I	5V digital or 1V pp analog	10 mA digital
PIN15	Channel G- For G- digital commutation signal	I	5V digital or 1V pp analog	10 mA digital

ai3140

### 5.1 Encoder type connection

Encoder type	Shielded cable	XEC ONNECTORPIN														
		1 B-	2	3 C+	4 C-	5 A+	6 A-	7 0V	8 B+	9 +5V	10 E+	11 E -	12 F+	13 F-	14 G+	15 G-
DE	8 pole	•		•	•	•	•	•	•	•						
SE	8 pole	•		•	•	•	•	•	•	•						
SESC	12 pole	•		•	•	•	•	•	•	•	•	•	•			
DEHS	14 pole	•		•	•	•	•	•	•	•	•	•	•	•	•	•

ai3160

- **DE:** 5V digital incremental encoder with A /A, B / B, C / C
- **SE:** 5V sinusoidal incremental encoder with A /A, B / B, C / C
- **DEHS:** 5V digital incremental encoder with A /A, B / B, C / C and three Hall sensor digital position signals (for AC Brushless motors)
- **SESC:** 5V sinusoidal incremental encoder with A /A, B / B, C / C and and two sin/cos traces for absolute position (for AC Brushless motors or positioning)

## 5.2 JUMPERS setting

Encoder/Jumpers setting	S11	S12	S13	S14	S15	S16	S17	S18	S19	S20	S21	S22	S23
DE	OFF	OFF	OFF	OFF	OFF	OFF	ON(*)	-	-	-	-	-	-
SE	ON	ON	ON	ON	ON	ON	-	-	-	-	-	B	B
SESC	ON	ON	ON	ON	ON	ON	-	A	A	A	A	A	A
DEHS	OFF	OFF	OFF	OFF	OFF	OFF	ON(*)	B	B	B	B	B	B

ai3150

- **DE:** 5V digital incremental encoder with A / A, B / B, C / C
- **SE:** 5V sinusoidal incremental encoder with A / A, B / B, C / C
- **DEHS:** 5V digital incremental encoder with A / A, B / B, C / C and three Hall sensor digital position signals (for AC Brushless motors)
- **SESC:** 5V sinusoidal incremental encoder with A / A, B / B, C / C and and two sin/cos traces for absolute position (for AC Brushless motors or positioning)

(\*) If the encoder is not provided with the zero channel, S17=OFF

### List of jumpers and dip-switch

Designation	F function	Factory setting
S0	The setting must not be changed	OFF
S1	The setting must not be changed	OFF
S5-S6	Terminating resistor for the serial interface RS485 ON=Termination resistor IN OFF=Noterminationresistor	ON
S8	Adaptation of the input signal of analog input 1 (terminals 1 and 2) ON=0...20mA/4...20mA OFF=0...10V/-10...+10V	OFF
S9	Adaptation of the input signal of analog input 2 (terminals 3 and 4) ON=0...20mA/4...20mA OFF=0...10V/-10...+10V	OFF
S10	Adaptation of the input signal of analog input 3 (terminals 5 and 6) ON=0...20mA/4...20mA OFF=0...10V/-10...+10V	OFF
S11-S12-S13 S14-S15-S16	Encodersetting ON= Sinusoidal SE or SESC encoder (see above) OFF=Digital DE or DEHS encoder (see above)	OFF
S17	Monitoring of the C-channel of the digital encoder ON=C-Channel monitored OFF=C-Channel not monitored (required for single-ended channels)	OFF
S18-S19 S20-S21	Encodersetting Pos.A=digital DEHS encoder (see above) Pos.B=sinusoidalSESCencoder (see above)	B
S22-S23	Analog input 3 enabling (alternative with SESC encoder) Pos.A=enabled Pos.B=disabled	A
S24	Jumper to disconnect 0V (of 24V) from ground ON=0V connected to ground OFF=0V disconnected from ground	ON
S25	Jumper to disconnect 0V (regulation section) from ground ON=0V connected to ground OFF=0V disconnected from ground	ON

ai4060

### List of dip-switch S3

Hp	3/4	1	2	3	5	7.5	10	15	20	
S1	ON	OFF	ON	OFF	OFF	ON	OFF	ON	OFF	
S2	OFF	ON	ON	OFF	OFF	OFF	ON	ON	OFF	
S3	OFF	OFF	OFF	OFF	ON	OFF	OFF	OFF	ON	
S4	OFF	OFF	OFF	OFF	OFF	OFF	OFF	OFF	OFF	
S5	ON	ON	ON	OFF	ON	OFF	OFF	OFF	OFF	
S6	OFF	OFF	OFF	OFF	OFF	OFF	OFF	OFF	OFF	
S7	OFF	OFF	OFF	OFF	OFF	OFF	OFF	OFF	OFF	
S8	OFF	OFF	OFF	OFF	OFF	OFF	OFF	OFF	OFF	
Hp	25	30	40	50	60	75	100	125	150	200
S1	ON	OFF	ON	OFF	ON	OFF	ON	OFF	ON	OFF
S2	OFF	ON	ON	OFF	OFF	ON	ON	OFF	OFF	ON
S3	ON	ON	ON	OFF	OFF	OFF	OFF	ON	ON	ON
S4	OFF	OFF	OFF	ON	ON	ON	ON	ON	ON	ON
S5	OFF	OFF	OFF	OFF	OFF	OFF	OFF	OFF	OFF	OFF
S6	OFF	OFF	OFF	OFF	OFF	OFF	OFF	OFF	OFF	OFF
S7	OFF	OFF	OFF	OFF	OFF	OFF	OFF	OFF	OFF	OFF
S8	OFF	OFF	OFF	OFF	OFF	OFF	OFF	OFF	OFF	OFF

ai4080

The drives are factory set, but when installing a space regulator card, remember to set dip-switch S3 according to the above table.

### 5.3 Maximum cable length for encoder terminals

Cable section [mm <sup>2</sup> ]	0.22	0.5	0.75	1	1.5
Max Length feet [m]	88 [27]	203 [62]	305 [93]	410 [125]	492 [150]

ai3130

## 6. Keypad operation

The keypad is made of a LCD display with two 16-digit lines, seven LEDs and nine function keys.

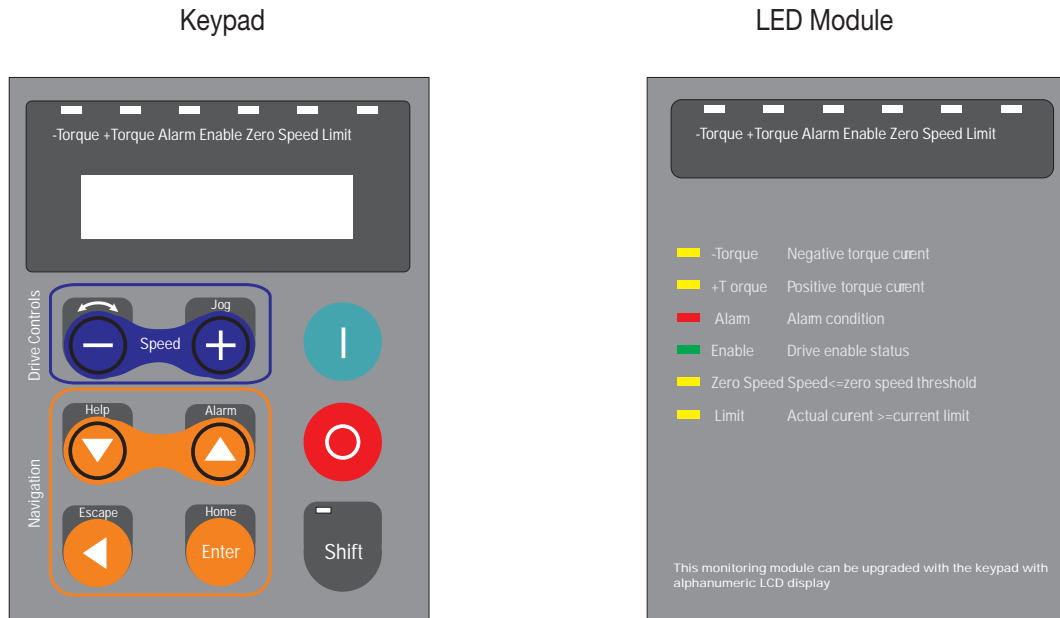

Keypad is used :

- To control the drive, when keypad use has been programmed (Main commands=DIGITAL.)
- To display the speed, voltage, diagnostics etc. during operation.
- To set parameters.

### LEDs

The LEDs present on the keypad and LED module are used to quickly diagnose the operating state of the drive.

Designation	Color	Function
-Torque	yellow	the LED is lit, when the drive operates with a negative torque
+Torque	yellow	the LED is lit, when the drive operates with a positive torque
ALARM	red	the LED is lit; it signals a trip
ENABLE	green	the LED is lit, when the drive is enabled
Zero speed	yellow	the LED is lit; it signals zero speed
Limit	yellow	the LED is lit, when the drive operates at a current limit
Shift	yellow	the LED is lit, when the second keypad functions are enabled

ai5010

Keypad buttons	Text reference	Function
	<b>[START]</b>	START button controls the Enable and Run modes of the drive if Main commands = DIGITAL and the Stop Mode is on. This is the default setting. When Main commands is set as TERMINALS the button is not active
	<b>[STOP]</b>	STOP button sets the main reference to zero when Main commands is set as DIGITAL (Pressing this button for 2 sec will cause the drive to be disabled, this will also cause the drive to coast stop). When Main commands is set as TERMINALS the button is not active.
	<b>[Increase] / [Jog]</b>	Plus button increases the speed reference for the Motor pot function. It is also the JOG command, when the shift button is selected.
	<b>[Decrease] / [Rotation control]</b>	Minus button decreases the speed reference for the Motor pot function. Rotation control changes the direction in Jog mode and Motor pot mode when the shift button is selected.
	<b>[Down arrow] / [Help]</b>	Down arrow - Used to change menu or parameter selection. In parameter and reference setting modes, it changes the value of the parameter or reference. Help - Function Not available ("Help not found" displayed when pressed with the shift button)
	<b>[Up arrow] / [Alarm]</b>	Up arrow - Used to change menu or parameter selection. In parameter and reference setting modes, it changes the value of the parameter or the reference. Alarm - Failure register displayed ( shift selected). Use the UP/DOWN Arrows to scroll through the last 10 alarms.
	<b>[Left arrow] / [Escape]</b>	Left arrow-in edit mode selects the digit of the parameter to modify. At other times it is used to exit from the setting mode. Escape - Used to exit from setting and Alarm displaying mode (when shift button is pressed)
	<b>[Enter] / [Home]</b>	[Enter] - Used to [Enter] a new value for a parameter in the parameter setting mode. Home - Used to go directly to BASIC MENU (when shift button is pressed)
	<b>[Shift]</b>	Shift button enables the second keypad functions (Rotation control, Jog, Help, Alarm, Escape, Home)



# Moving inside a menu

3rd level

2nd level

Main menu

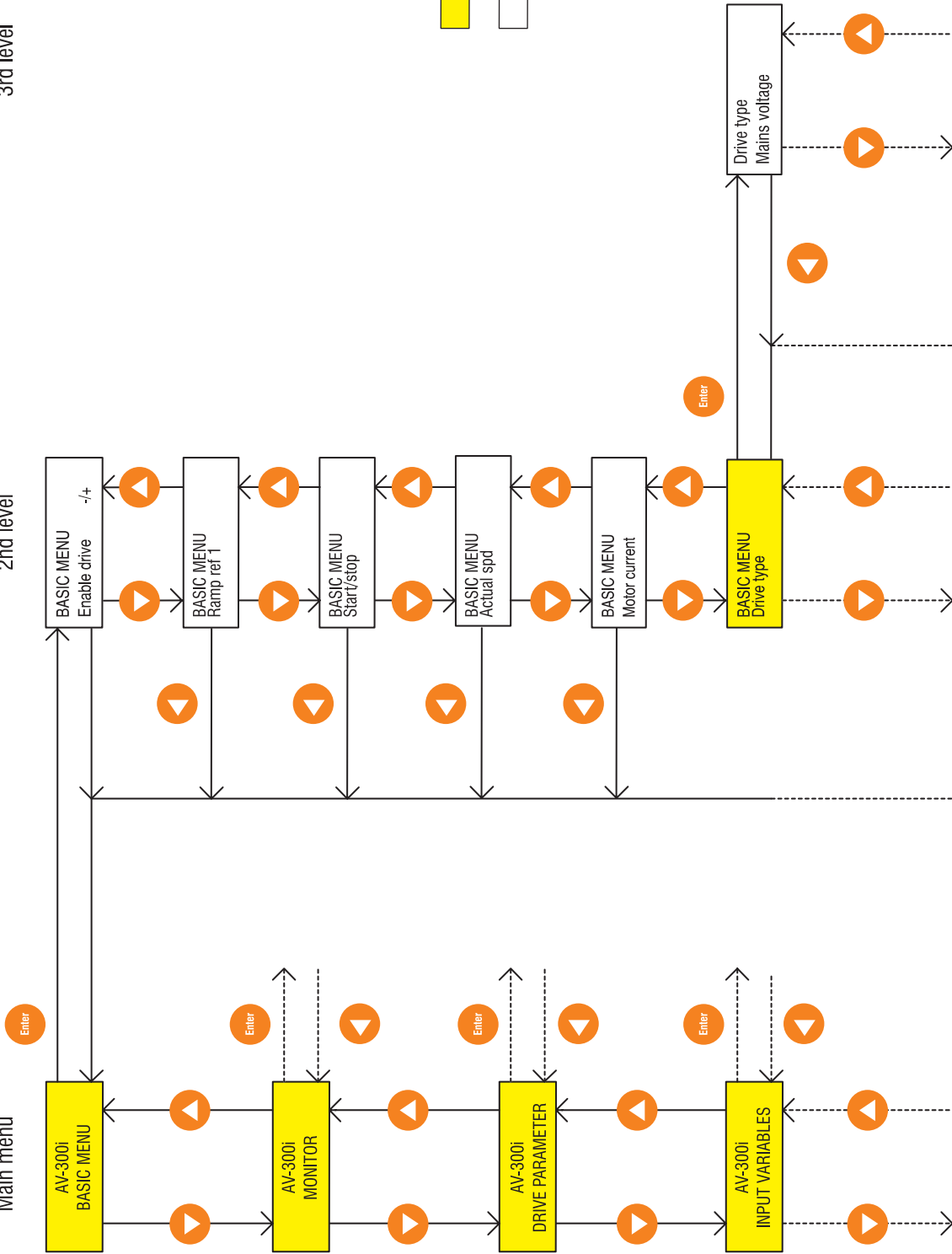
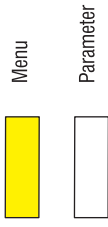

## 7. Pre Power Checks

The following should be checked **before switching ON the Drive**:

### Grounds / Grounding

- Verify ground connections between the drive and motor
- Verify AC Input, AC Output and control wiring aren't grounded

### Connections

- Verify AC Input (U1/L1, V1/L2, W1/L3), AC Output (U2/T1, V2/T2, W2/T3), DC link connection (C,D), Motor thermistor (78, 79), OK Relay (80, 82), Relay 2 (83,85) and regulation board points (1.....46, XS, XE) connections.

### Regulator Terminal Board Inputs:

- 12 ENABLE DRIVE (close to activate)
- 13 START (close to activate)
- 14 FAST STOP (open to cause a stop)
- 15 EXTERNAL FAULT (open to cause a stop)
- 16 Common for terminal board inputs
- 18 + 24V Common
- 19 +24VDC (internal power supply)

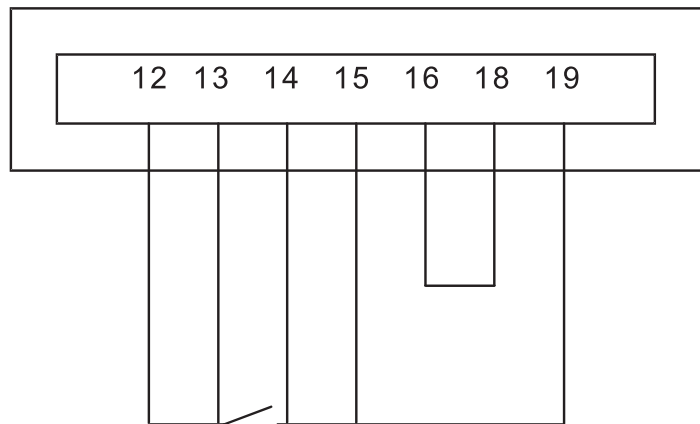

Set inputs on the regulator terminal board as follows:

- Enable drive (terminal 12) and Start (terminal 13) OPEN
- Fast stop (terminal 14) and External fault (terminal 15) CLOSED
- Record motor name plate data, encoder information, gearbox data.

### MOTOR DATA

HP (kW)		Cos phi (power factor)	
Amps		Tach type	
Volts		Tach PPR	
Hz		Motor rotation for machine fwd direction [CW/CCW]	
Rpm		Gearbox ratio	

Dai54123

## 8. Quick tuning

1. After a complete check of wiring, turn the power on:

- The following voltages must be present:

Terminal 7, +10V to terminal 9 (on regulation board)

Terminal 8, -10V to terminal 9 (on regulation board)

Terminal 19, +24...30V to terminal 18 (on regulation board)

- Check DC link voltage by pressing **[Down arrow]** to get “Monitor”, then **[Enter]**, then **[Down arrow]** to “measurements”, then **[Enter]**, then **[Down arrow]** to “DC link voltage”, then **[Enter]**.

The value should be:

275-357 VDC for 230 VAC input

480-650 VDC for 400 VAC input

550-715 VDC for 460 VAC input

If the DC Bus is not within these limits, check the AC line voltage.

2. **Default to Factory Values:** If you are not certain of the drive configuration, it will be necessary to default to factory values or copy in a file from a PC. It is important to be certain you are starting from a known configuration. To default to factory values:

- **Default to working memory:** Push **[Left arrow]** to get back to “Monitor”, then **[Down arrow]** to “Spec Functions” and then **[Enter]**. Push **[Down arrow]** to “Load Default” and **[Enter]**. The factory values will now be loaded into the working memory, the original values are still in permanent memory.

### Note:

Step 2 can be skipped if you know that the drive is loaded with factory defaults (as it comes out of the shipping carton).

### 3. Set Line Voltage:

- Press **[Left arrow]** to “Spec functions” then **[Up arrow]** to “BASIC MENU”, then **[Enter]**, then **[Down arrow]** to “Drive type”, then **[Enter]** to “Mains voltage” and **[Enter]**. Now using the **[Up arrow]** / **[Down arrow]** keys, change the voltage to your nominal AC input rating. Then **[Enter]** to set the value.

### 4. Adaption to maximum ambient temperature:

- Press **[Down arrow]** to “Ambient temp” then **[Enter]**. Now using the **[Up arrow]** / **[Down arrow]** keys, set the maximum ambient temperature value: 40°C or 50°C, then **[Enter]**.

### 5. Load Default Motor Values:

- Press **[Left arrow]** until you are back to “BASIC MENU” and then **[Down arrow]** to Drive Parameter, then **[Enter]**, then **[Down arrow]** to Motor Parameter, **[Enter]**, then **[Down arrow]** to “Load Motor Par” and **[Enter]**. Use the **[Up arrow]**/**[Down arrow]** keys until

the display is the correct motor voltage, then **[Enter]**. For 460 VAC motors, select 460, and for 380/400 VAC motors select 400.

### 6. Set Actual Motor Data:

- Press **[Left arrow]** until back to “Drive parameter”, then **[Enter]** to get “Mot plate data” and **[Enter]** to “Nominal Voltage” then **[Enter]** again to see the value. Using the **[Up arrow]**/**[Down arrow]** keys to change the value and the **[Left arrow]** to move the character position. When correct press **[Enter]**.
- Press **[Down arrow]** to “Nominal speed”, **[Enter]**, then use the **[Up arrow]** / **[Down arrow]** keys to get the nominal speed on the motor nameplate. Press **[Enter]** to set data. Note, some manufacturers of vector motors put the synchronous speed (600, 900, 1500, 1800, 3600 RPM), rather than the slip speed at 60 Hz on the nameplate. If this is done, you MUST estimate slip speed. Figure 20 rpm less than the synchronous speed for these cases.
- Press **[Down arrow]** to “Nom frequency” and **[Enter]** and set to the nominal frequency on the nameplate (50 or 60 Hz) Press **[Enter]** to set data.
- Press **[Down arrow]** to “Nominal current” and **[Enter]** and set to the nominal current on the nameplate (rated current) by using the **[Up arrow]** / **[Down arrow]** keys. Press **[Enter]** to set data.

If the drive will “not accept” the value entered, the most common cause is trying to **[Enter]** a value for “Nominal Current” that is less than 30% of the drive rating. This is not allowed due to parameter problems encountered with a small motor and a large drive. Go back to step 6 and repeat the entries. If this doesn't work, see the Overflow List in the troubleshooting section of this book.

- Press **[Down arrow]** to “Cos phi” and **[Enter]** and set the nominal power factor on the nameplate by using the **[Up arrow]** / **[Down arrow]** keys (accept the default if you don't know). Press **[Enter]** to set data. Press **[Down arrow]** to “Base Voltage” and **[Enter]** and set the base voltage by using the **[Up arrow]** / **[Down arrow]** keys (usually rated voltage). Press **[Enter]** to set data. Look in the manual for both Base Voltage and Base Frequency when operating the motor above normal synchronous speed.
- Press **[Down arrow]** to “Base Frequency” and **[Enter]**, set to the base frequency by using the **[Up arrow]** / **[Down arrow]** keys (usually rated frequency). Press **[Enter]** to set data.
- Press **[Down arrow]** to “Take motor par” and **[Enter]** and set all the motor parameters. **If, when you do this, a message saying “Over-range error XXX” appears, there is something wrong with the data you have entered.** The drive has NOT ACCEPTED the values you have entered. The most common cause

of this is trying to **[Enter]** a value for “Nominal Current that is less than 30% of the drive rating. This is not allowed due to problems encountered with a small motor and a large drive. Try to go back to the **beginning** of step 6 and repeat the entries. If this doesn't work, see Overflow list in troubleshooting section or contact your service office.

#### 7. Set Drive Base Values:

- Press **[Left arrow]** until back to “drive parameter” then **[Down arrow]** to “configuration”, then **[Enter]**.
- Press **[Down arrow]** to “Speed Base Value” then **[Enter]** and set the nameplate rated full load speed on the motor nameplate, press **[Enter]**. This bases all speed related calibrations on top motor speed.
- Press **[Down arrow]** to “full load current” then **[Enter]** and set the DRIVE (not motor) rated full load current on the drive nameplate by using the **[Up arrow]** / **[Down arrow]** keys, then press **[Enter]** to set. This bases all current related calibrations on motor “Full Load Amps” (FLA).

#### 8. Set Regulation Mode: (Sensorless vect, V/f or Field oriented mode )

- Press **[Up arrow]** to “Regulation mode”, then **[Enter]** and use **[Up arrow]** / **[Down arrow]** keys to select “V/f”, “sensorless vect” or “Field oriented” then **[Enter]**.
- If “Field oriented” mode is selected:
- Press **[Down arrow]** until to “Motor spd fbk”, then press **[Enter]**, **[Down arrow]** to “Encoder 1 type”, then **[Enter]**. Use the **[Up arrow]**/**[Down arrow]** keys to select sinusoidal encoder or digital encoder, then **[Enter]**.
- Press **[Down arrow]** to “Encoder 1 pulses”, then **[Enter]** and set the value using the **[Up arrow]**/**[Down arrow]** keys to the PPR (pulses per revolution) of your encoder, **[Enter]**.
- Press **[Down arrow]** four times to “Refresh Enc 1” then **[Enter]**, “Enable” **[Enter]**, this enables the Speed fdbk Loss Alarm.

#### 9. Speed Limit:

- Press **[Left arrow]** until “Basic Menu”, then **[Down arrow]** to “Limits”, then **[Enter]** for “Speed Limits”, then **[Enter]** for “Speed Amount”, then **[Enter]** to “Speed Min Amount”. Press **[Down arrow]** to “Speed Max Amount”, and **[Enter]**. Change the value from 5000 RPM to the maximum speed of the motor use the **[Up arrow]**/**[Down arrow]** keys as before (for now set it to 105% of the rated motor speed). Press **[Enter]**.

#### 10. Prepare for Self Tune:

- The keypad will be used for this purpose but the I/O needs to be connected properly to the enable/disable functions.

#### 11. Save Parameters:

- Press **[Left arrow]** to “limits”, then **[Up arrow]** until “Basic Menu” then **[Enter]**, then **[Down arrow]** to “save parameters”, then **[Enter]**.

The display will read “wait” until the values are permanently stored.

#### 12. Self Tune:

Make sure power is on and drive not enabled.

Close the switch on terminal 12 (hardware enable has 24 Vdc on it).

- When the enable switch is made, Press **[Left arrow]** until “Basic Menu” then **[Down arrow]** to “Drive Parameter”, then **[Enter]**, then **[Down arrow]** to “motor parameters” and **[Enter]**. Press **[Down arrow]** to “Self Tuning” and **[Enter]** to “self tune 1”. Press **[Enter]** to “start part 1” and **[Enter]**, “start part 1 ?” and **[Enter]** again. The keypad should show the “enable” led illuminated, if not, make sure that you have the jumpers (or external switches) set so that 24 VDC exists on terminal boards 12, 13, 14, 15, with respect to 16 or 18.
- You should now see “measuring Rs” (stator resistance). Wait until the display says “end”, then disable the drive (open the switch to 12) and push **[Left arrow]** twice to see “self tune 1”, press **[Enter]**, then **[Down arrow]** all the way to “take val part 1” and **[Enter]**. The display will read “wait” until the values are stored. The motor shaft must not move during the procedure. If necessary, the motor shaft must be locked.

#### NOTE:

“xxx range error” or “timeout” messages may also occur in some extreme parameter ranges. Repeat the tune in this case. If error messages are persistent see troubleshooting section.

#### 13. Self Tune part 2:

The initial part of self tuning that can be done without the motor rotating has been accomplished. Now, to get the best possible tuning, the motor needs to turn with no load attached to the shaft. For this we use Self tune mode 2a. If, for any reason, the motor cannot be made to rotate with no load, then a “close” level of tuning can still be accomplished by selecting Self tune mode 2b.

- Now press **[Left arrow]** to see “self tune 1” then **[Down arrow]** to “self tune 2a or 2b and press **[Enter]**. Enable the drive using the switch to terminal 12. Press **[Enter]**, “start part 2a ?” or “start part 2b ?” then **[Enter]** and see “measure sat 2a (or b)” will appear and the motor shaft will turn (if “self tune 2a” is select). Wait until the display says “end”, press **[Left arrow]** to see “self tune 2a (or b)” then **[Enter]** and press **[Down arrow]** to see “take val part 2a (or b)”. Disable the drive (switch off terminal 12), then **[Enter]**.

**NOTE:**

“xxx range error” or “timeout” messages may also occur in some extreme parameter ranges. Repeat the tune in this case. If error messages are persistent see troubleshooting section.

If there was some reason you did not want to keep these values permanently, but only wanted to try to run the drive with them, there is no need to save them to permanent memory. If power is cycled however, these values will be lost unless the “Save Parameter” function is used.

**14. Self tune part 3:**

The third part of self tuning (Speed regulator tuning) identifies the total inertia at the motor shaft, the friction value and computes the proportional and integral gains of the speed regulator. The motor needs to be free to turn with load attached to the shaft.

**NOTE:**

When regulation mode = field-oriented, the encoder needs to be verified before running Self Tune 3. Refer to page 22 “Encoder Verification”. After this verification procedure, put the regulation mode back to field oriented.

**WARNING !**

**This procedure requires free rotation of the motor shaft coupled to the load. The Start/Stop command is ignored, therefore it can not be used on drives with limited travel, or when free rotation presents a safety problem.**

**CAUTION !**

**The test is performed using the torque limit value set in Test T curr lim parameter. The torque is applied in a step fashion, with no ramp profile. Therefore, the mechanical transmission must not have significant backlash, and it must be compatible with operation at the torque limit set in the Test T curr lim parameter. The user can reduce the torque limit to a suitable value via the Test T curr lim parameter.**

**Note !**

- Application where the system inertia coupled to the motor shaft is much higher than the motor inertia value, increase the Test T curr lim parameter to avoid “Time out” error.
- **This procedure is not suitable for use with “hoist” or “elevator” drives.**
- Encoder feedback is required when Field oriented mode is selected.

- Set the current limit (BASIC MENU\ T Current lim +/-) to a value compatible with the motor size and load. (Example when motor is 1/3 of the Drive power, the limit should be reduced compared to the default value).
- Select the torque current value to be used during the test via the **Test T curr lim** parameter
- Now press **[Left arrow]** to see “self tune 2a or 2b” then **[Down arrow]** to “self tune 3” and press **[Enter]** to Fwd-Rev spd tune, then **[Enter]**. Set the motor shaft direction for this test: Forward or Reverse by using **[Up arrow]** / **[Down arrow]** keys. Press **[Enter]** to set the selection.
- Enable the drive using a switch on terminal 12 [and close terminal 13 to terminal 19 if Speed control function is enabled (default)]. Press **[Down arrow]** to “Start part 3” then press **[Enter]**, “start part 3 ?” then **[Enter]** and see “measure speed” will appear and the motor will turn. Wait until the display says “end”, press **[Left arrow]** to see “self tune 3” then **[Enter]** and press **[Down arrow]** to see “take val part 3”. Disable the drive, then **[Enter]**. You are now finished with the initial set up and tuning with values stored in only in the “working memory”.

**NOTE:**

“xxx range error” or “timeout” messages may also occur in some extreme parameter ranges. Repeat the tune in this case. If error messages are persistent see troubleshooting section.

**NOTE:**





If there was some reason you did not want to keep these values permanently, but only wanted to try to run the drive with them, there is no need to save to permanent memory. If power is cycled however, these values will be lost unless the next step is taken.

To save all values to permanent memory, select **Save parameters** and press **[Enter]**.

**15.Set up for Running:**

First, before saving, let’s put the drive into the configuration you want to run it in.

The drive is factory setting to run through the Increase **[+]** and Decrease **[-]** keys (**Enable motor pot parameter** = Enabled), see the following instruction to run.

Control buttons	Sequencing	Display
	Press START button to command the Drive to the Enable and Run state	
	Press STOP button commands to stop the Drive from the Run state	
	Press to display the current reference value and to increase the reference value and accelerate the drive.	<b>Motor pot oper.</b> <b>+0 [rpm] POS</b>
	Press to decrease the reference value and decelerate the drive.	<b>Motor pot oper.</b> <b>-0 [rpm] NEG</b>
	Press SHIFT and [-] to change the motor shaft rotation	

## 8.1 Motor Potentiometer function

### Note!

(Main commands = DIGITAL)

Enable drive, terminal 12 connected to 24VDC

Start, terminal 13 connected to 24VDC

### Resetting the speed reference value using Mot pot function

- Press **[STOP]** button to stop the motor
- Press **[Left arrow]** until to “Basic menu”, then **[Down arrow]** to “Functions”. **[Enter]** to motor pot, then **[Enter]** to “enab motor pot”, press **[Down arrow]** to motor pot reset, then **[Enter]**.

The display will read “ready” until the reference value is set to zero.

Set the motor pot to “disable” (**Enable motor pot** parameter = Disable) if you will want to use an analog voltage on terminal 1 for speed reference.

### Jog function

#### Note!

This function is enabled as a default setting (**Enable jog** parameter = Enabled). Speed reference value = 100 rpm.

(Main commands = DIGITAL)

Enable drive, terminal 12 connected to 24 VDC

Start, terminal 13 connected to 24 VDC

Press **[SHIFT]** and **[+]** to run, the speed will be displayed

Press **[-]** to select the motor shaft rotation

Press **[jog]** to run the other direction

Press **[Left arrow]** to exit from jog operation

### Changing jog reference

Press **[Down arrow]** until “Functions”, **[Enter]**, then **[Down arrow]** until “Jog reference”, **[Enter]**, using the **[Up arrow]/[Down arrow]** keys to change the value and the **[Left arrow]** to move the character position, set the reference value, then **[Enter]**.

If there are other changes you might want to make to set up (see Options), **do them now**, and complete the following step to put everything into permanent memory.

### Saving all values to Permanent Memory:

- Press **[Left arrow]** back to “Configuration” then **[Up arrow]** to “basic menu” and **[Enter]**. Press **[Down arrow]** to “save parameters” and **[Enter]**. Parameters are now stored permanently.



## 9. Options

**Encoder verification:** Set the Drive in V/f mode and run the motor, enable and start the drive and set an analog reference. If the reference is positive on terminal 1 with respect to 2 (common) the motor should be turning clockwise. With the motor turning clockwise (looking at the drive end), monitor the encoder measurement by selecting “Monitor/measurements/speed/speed in rpm/Enc 1 speed”. The speed should be positive, not negative. If it is negative, then A and A- or B and B- should be interchanged on the encoder. Now return to the “Set Up for Running” section.

**Current Limit:** The current limit will have been set to approximately 136% by default in the previous setup (exact number is a function of the power factor but the difference is very small). The value actually set can be verified by (from “Basic Menu”) pressing down/right arrow to “Limits”, then **[Enter]**, then down/right arrow to “current limits”, then **[Enter]**, then down right arrow to “T current lim” and **[Enter]**. The value of T current limit can be changed to a higher (or lower) number. Bear in mind that the ultimate limits are based on the capacity of the drive, not the motor. T current is the torque producing component of total current. Settings in excess of 200% are possible, although the motor may not be able to handle this current. Current Limit restricts the magnitude of the torque current reference. The drive has other alarms and faults to provide motor and drive current protection.

**I/O Configuration:** This drive can be configured in several ways.

The standard drive has three standard analog inputs and two analog outputs as well as six digital inputs and two digital outputs. These are assignable and configurable. **The drive is defaulted already to provide the analog outputs as Actual speed and Torque current.** To set up the drive for two analog outputs (one for speed and one for load) for metering or other purposes, do the following:

Refer to the “Control terminals” section of this guide showing a description of the connections to the regulator. A more detailed description and discussion of the I/O are shown in the manual. The analog outputs are defaulted to a scale of 1, which means 10 volts out at the max parameter value. In other words, if analog output 1 is set to max speed then max speed will be scaled to 10 VDC (maximum output voltage available) at “Speed Base Value”. If you wanted 5 volts out at max speed then set the scale to 0.5. If the output were set to Torque current then 10 VDC would be rated current. If you wanted the output to be 10 Vdc at 150% of “Full Load Current” then the scale would be 0.66. The standard factory default is already set up for speed (with scale factor of 1) on analog output 1 (terminals 21 and 22) and load (Torque current, with scale factor of 1) on analog output 2 (terminals 23 and 22). Note that terminal

22 is a common for both the outputs. This common can be grounded, and should be grounded somewhere, preferably at the load device (meter).

**How to disable analog input 1 as ramp reference:** Analog inputs 2 and 3 are defaulted to off, #1 is defaulted to Ramp ref 1.

- Press **[Up arrow]/[Down arrow]** to “I/O Config”, then **[Enter]**.
- Press **[Down arrow]** to “Analog inputs”, then **[Enter]** for Analog input 1, then **[Enter]** to Select input 1, then **[Enter]** to display the setting, which will be “Ramp ref 1”.
- Press **[Up arrow] / [Down arrow]** keys until “OFF” is displayed, then **[Enter]**.

**How to enable analog input 2 as ramp reference**

- Press **[Up arrow]/[Down arrow]** to “I/O Config” and press **[Enter]**, then down right arrow to “analog inputs” then **[Enter]** for “analog input 1” then **[Down arrow]** to “analog input 2. Then **[Enter]** to “select input 2”; then **[Enter]** again to see the set up. It says “OFF”. Use the **[Up arrow] / [Down arrow]** keys to display “Ramp ref 1” and **[Enter]**. This means the analog input 2 (terminals 3 and 4) will be the ramped (accel/decel) speed reference for the drive.

The manual shows the entire configuration of other I/O in the drive.

## 10. Quick Tuning Guide for Factory Configured (or pre-configured) Drives

When the drive configuration has already been set and you are simply fine tuning the drive you can ignore most of the preceding procedure. It is recommended that you go through the steps anyway, if the data is suspect. You can just use the **[Left arrow]** key rather than the **[Enter]** key in all the steps in which the entry is found to be correct. Start with step 4 of the full procedure and **do not default the parameters to factory parameters.** If there is any question about whether the existing setup should be saved or not, then use the configuration tool software that came with the drive and save the file to a PC first so it can be used later.



# 11. Troubleshooting

## Overflow list

CODE	CAUSES
10 ; 54	The ratio between the Encoder 1 pulses[416] and the number of motor pole pairs must be higher than 128
3 ; 4	The Stator resistance [436] value is too high. The motor is not compatible with the drive size used.
5 ; 8 ; 9 ; 15	The Leakage inductance [437] value is too high. The motor is not compatible with the drive size used.
16 ; 24	The Rotor resistance [166] value is too high. The motor is not compatible with the drive size used.
17	The Nominal voltage [161] and Nom frequency [163] values produce motor nominal flux that is too high. - The Nominal voltage value is too high and/or the Nom Frequency value is too small.
18	The Base voltage [167] and Base frequency [168] values produce motor nominal flux that is too high. - The Base voltage value is too high and/or the Base frequency value is too small
23	The ratio between nominal flux (Nominal voltage, Nom frequency) and working flux (Base voltage, base frequency) is too high. - Verify the above parameters value. The Magnetizing current [165] value is too high. - Verify that this value is lower than Full load curr.
27	The Base voltage value is too high. The maximum value is 500 VAC.
28	The Base frequency value is too high. This value must be lower than 500Hz
59	The Magnetizing working curr [726] is too high. - Verify that the nominal flux value (Nominal voltage and Nom frequency) is lower than the working flux value (Base voltage and Base frequency). Check the parameters value. The Magnetizing current value is too high. - Verify that this value is lower than Full load curr.
64	The Motor cont curr [656] value, of the motor thermal protection function (menu Ovld mot contr), produces a continuous current that is too low in comparison to the used inverter size. This error can also be due to a too low setting of the Nominal current [164] parameter ( $\leq 0.3 \times I_{2N}$ ).
66	The Nominal speed [162] value is wrong. The set value produces too small (or too high) slip value.

## List of Self-tuning Error Messages

### Generic messages

<u>Description</u>	<u>Note</u>
“Drive disabled”:	Provide enable input by setting terminal 12 high.
“Not ready”:	“ <b>Take values part 1</b> ”, “ <b>Take values part 2a</b> ”, “ <b>Take values part 2b</b> ” or “ <b>Take values part 3</b> ” can not be executed because the measurement has not been completed correctly. Repeat self-tune procedure.
“Time out”:	Measurement has not been completed in the proper time.
“Start part...?”:	Press [ENTER] to confirm start of measurement.
“Tuning aborted”:	Measurement aborted by user ([SHIFT] / [Escape] button has been pressed).
“Set Main cmd=Dig”:	Go to CONFIGURATION menu and set <b>Main commands</b> = digital.
“Set Ctrl=Local”:	Go to CONFIGURATION menu and set <b>Control mode</b> = Local.
“Reg mode NOK”:	<b>Self tune part 3</b> can only be executed with <b>Regulation mode</b> = <b>Field oriented</b> or <b>Regulation mode</b> = <b>Sensorless vect</b> . Go to BASIC MENU and set <b>Regulation mode</b> properly.
“Inertia range”:	<b>Self-tuning part 3</b> procedure has found an inertia motor value too low, for this reason it cannot calculate the speed regulator gains. Try to repeat the self-tune procedure to eliminate accidental measurement errors.  If this error persist , do not use the “ <b>Take val part 3</b> ”command. The speed regulator will probably be stable with the factory gains. It is possible to optimize the speed regulator by manual tuning .

### Measurement error messages

These messages may occur when extreme parameter values have been identified. It may be useful to retry the self tune command when any of the following messages occur. If the messages persist, alternative manual tuning procedures should be used.

<u>Description</u>	<u>Note</u>
“No break point”	<b>Self-tune Part 1</b> failed. Check the connections between the drive and the motor and repeat self-tune Part 1.
“Overspeed”	<b>Self-tune Part 3</b> detected a much higher speed than expected. Repeat <b>Self-tune 1</b> or the manual tuning that was performed.
“Drive stalled”:	Increase value of parameter <b>Test T curr lim</b> and repeat <b>Self tune 3</b>
“Load applied”:	Nominal zero load torque at standstill was detected. <b>Self tune 3</b> is impossible for this type of load.
“T curr too high”:	Reduce value of parameter <b>Test T curr lim</b> for <b>Self tune 3</b>
“Friction null”:	Value of friction is zero or lower than the accuracy limit of the control system.

## ***Failure alarms in the keypad display***

<b><u>Failure alarm</u></b>	<b><u>Possible causes</u></b>
<b>BU overload</b>	The braking duty cycle is out of the allowed range
<b>Bus loss</b>	Failure in the Bus connection (only with interface Bus option card) Check the Bus connection EMC compatibility problem, check wiring.
<b>Curr fbk loss</b>	Failure in the connection between regulation card and TA transformer. Check the connection cable on XTA connector.
<b>DSP error</b>	Processor program error Switch off the drive and restart If unsuccessful there is probably an internal fault. Contact your service office.
<b>Enable seqerr</b>	Drive is powered up or RESET* with the ENABLE input connected to 24 VAC (picked up) and the drive in "terminal mode". Refer to CONFIGURATION/Main Commands.
<b>External fault</b>	External failure, reported on terminal 15 If the "External fault" message is not displayed, the connection is missing between terminals 16 and 18 (reference point) and/or 15 and 19. If the "External fault" message is displayed: <ul style="list-style-type: none"><li>- The signal on terminal 15 is missing (15 ... 30 V to terminal 16). With an external voltage supply, commons must be connected together.</li></ul>
<b>Failure supply</b>	Fault in the voltage supply; the voltages are below the permitted value CAUTION: switch off voltage before removing terminal strips. In most cases the cause is in the external wiring. Pull out the plug-in terminal strips of the regulator card and enter the Reset command. If no other failures are reported, check your wiring for a short-circuit, check cable shielding. If this has not corrected the fault, try to RESET* once more. If still unsuccessful, the fault is probably internal. Contact your service office.
<b>Heatsink ot</b>	(For sizes from 22kW ... and higher). Temperature of the heatsink drive too high. Failure of device fan. Failure in the IGBT module on power section. Fast overload current duty cycle.
<b>Heatsink sensor</b>	Ambient temperature too high Failure of drive fans Dirty heatsink
<b>Intake air ot</b>	(For sizes from 30 Hp and higher). Temperature of the cooling air too high. Failure of drive fans Air intake obstructed

<b>Interrupt error</b>	<p>An unused interrupt has occurred</p> <p>Switch off the drive and restart</p> <p>If still unsuccessful, the fault is probably internal. Contact your service office</p>
<b>Module overtemp</b>	<p>(For sizes from 1 Hp to 20 Hp). Temperature of the IGBT module is too high</p> <p>Failure of drive fan</p> <p>Failure in the IGBT module in the power section.</p> <p>Fast overload current duty cycle.</p>
<b>Output stages</b>	<p>Internal Overcurrent failure of IGBT power section</p> <p>Switch off drive and restart</p> <p>If unsuccessful, contact your service office</p>
<b>Overcurrent</b>	<p>Overcurrent in the motor circuit</p> <p>Short-circuit or ground fault at the output of the drive</p> <p>Current regulator tuned incorrectly</p> <p>Message appears when switching on the drive: drive is connecting to a motor that is running. Auto capture function must be activated</p> <p>Switch off drive and restart</p> <p>If unsuccessful, contact your service office</p>
<b>Overvoltage</b>	<p>Overvoltage on the DC Bus due to energy regenerated from motor</p> <p>Lengthen deceleration ramp. If not possible:</p> <p>Use a BU... braking unit to increase the energy absorption capability</p>
<b>Overtemp Motor</b>	<p>Overtemperature of the motor (indicated via thermistor on terminals 78/79)</p> <p>Cable between thermistor in motor and terminals 78 and 79 interrupted</p> <p>Overheating of motor:</p> <ul style="list-style-type: none"> <li>- Load cycle too extreme</li> <li>- Ambient temperature at motor location too high</li> <li>- Motor has an external blower and it has failed</li> <li>- Motor does not have an external blower: load too large at low speeds. The cooling effect of the fan on the motor shaft is inadequate for this load cycle. Change cycle or install an external blower</li> </ul>
<b>Regulation ot</b>	<p>Temperature of the drive regulator card is too high</p> <p>Ambient temperature too high</p>
<b>Speed fbk loss</b>	<p>Speed feedback loss</p> <p>Encoder not connected, or incorrectly connected or not supplied:</p> <p>Select the <b>Enc 1 speed</b> parameter in the MONITOR \ Measurement \ Speed \ Speed in rpm menu.</p> <ul style="list-style-type: none"> <li>- With the drive disabled, manually turn the motor clockwise (viewed from the front of the shaft). The value indicated must be positive.</li> <li>- If the indicated value does not change or random values are shown, check the power supply and the cabling of the encoder.</li> <li>- If the indicated value is negative, reverse the encoder connections. Exchange channel A+ and A- or B+ and B-</li> </ul>

**Undervoltage** Line voltage parameter incorrectly set. Remedy: set parameter correctly and then acknowledge the failure via RESET\*.

The incoming voltage to the power section of the device is too low due to:

- too low an AC input voltage or extreme line dips
- poor cable connections (e.g. terminals on contactor, choke, filter ... not properly tightened).  
Remedy: check connections.

\* To RESET the alarms press **[Escape]**. If **Enable** and **Start** commands are configured for terminal mode, remove both commands before "Reset". To RESET remove +24V potential from these terminals.

**Note:**

The RESET alarm operation can be also configured for a digital input.

## ***Other faults***

### **Failure**

### **Possible causes**

#### **Motor not turning**

Failure alarm is displayed: see above

Once the error has been corrected enter the failure Reset command

Keypad display is dark: AC voltage supply to terminals U1/V1/W1 missing or an internal fuse is faulty

Enable and/or start command missing (Check configuration of the reg. terminals)

Drive not accepting commands: incorrect or wrong operating mode

Protective device ahead of the power supply has tripped: protective device incorrectly sized or input jumper faulty

The analog input used for the reference value was not assigned or assigned incorrectly

#### **Motor turning in the wrong direction**

Polarity of the reference signal incorrect

Motor incorrectly connected. CAUTION: if the motor rotation is reversed, two encoder cables (A+ and A- or B+ and B-) have to be reversed also.

#### **Motor not reaching nominal speed**

Drive is encountering a speed limit. Remedy: check **Speed max amount**, **Speed max pos** and **Speed max neg** parameters

Drive working at current limit (LED llimit) Possible causes:

- Motor overloaded
- Inverter sized too small
- Incorrect V/f characteristics set
- T current lim reduction selected via Torque reduct parameter

The entered value for the number of encoder pulses is too high. Remedy: check the parameter "encoder 1 pulses" and set the correct value.

An override signal is reducing the main reference value.

Remedy: check the configuration

Speed base value parameter set too low

### Motor accelerates immediately to maximum speed

Reference set via analog input: Check whether the signal varies from min. to max.  
Potentiometer used for reference: Is there a 0V (common) connection present?

Encoder not connected, or incorrectly connected.

Select the **Enc 1 speed** parameter in the MONITOR \ Measurement \ Speed \ Speed in rpm menu.

- With the regulator disabled, manually turn the motor clockwise (viewed from the front of the shaft). The value indicated must be positive.
- If the indicated value does not change or if random values are shown, check the power supply and the cabling to the encoder
- If the indicated value is negative, reverse the encoder connections. Exchange channel A+ and A- or B+ and B-.

### Motor accelerates too slowly

Ramp value incorrectly set

Motor running at max. current

- Motor overloaded
- Drive sized too small
- Incorrect V/f characteristics set

### Motor decelerates too slowly

Ramp value incorrectly set

### Motor turns slowly, although reference value = Zero

Minimum speed parameter selected

Interference due to unused analog input. Remedy: set unused analog inputs to OFF

Disconnect reference on the analog input

- If drive now stands still, the effect is due to the cable resistance of the 0V (common) leg.
- Use the offset compensation on the analog input. Set **Offset input xx** parameter so that the drive stands still.

### Output voltage oscillates under load

The value for **Rotor resistance** is not correct. See section "Checking and manual tuning of rotor resistance for field oriented mode" in the AV-300i instruction book.

### Motor not supplying the maximum torque or maximum output power

The value for **Magnetizing curr** is less than required for the connected motor.

- The ratio **Output voltage / Output frequency** in the MONITOR / Measurements menu should be approx equal to the ratio of **Base voltage / Base frequency**
- Drive working at current limit
- Check whether the value for **Full load curr** in the CONFIGURATION menu is correctly set
- Check the value for the current limit
- The value for **Magnetizing curr** and/or **Rotor resistance** parameters is not correct. Optimize the tuning as described in the instruction book.

### **The speed during acceleration with maximum current is not linear**

Reduce the **Speed I** and **Speed P** proportionally. If this does not lead to an improvement, optimize the regulator per the instruction book.

### **Speed oscillating**

Check **Speed P** and **Speed I** parameter

If the operating point is in the constant Hp range, check the **Flux P** and **Flux I** parameters  
Incorrect value for Rotor resistance

Remedy: Optimize the tuning as described in the AV-300i instruction book.

### **Drive not reacting to adaptive speed regulation**

Adaptive speed regulation not enabled. **Enable spd adap** = Enabled

Adap reference not assigned to an analog input

### **Motor potentiometer function not executed**

Function not enabled. **Enable motor pot** = Enabled

With operation via the terminal strip: **Motor pot up** and/or **Motor pot down** and **Motor pot sign** were not assigned to digital inputs

### **Jog operation not possible**

A start command is still present

Function not enabled. **Enable jog** = Enabled

With operation via terminal strip: **Jog +** and/or **Jog -** were not assigned to digital inputs.

### **Internal speed reference values not actuated**

Function not enabled. **Enab multi spd** = Enabled

With operation via terminal strip: **Speed sel 0**, **Speed sel 1** and **Speed sel 2** were not assigned to digital inputs.

### **Multi-Ramp function not reacting**

Function not enabled. **Enab multi rmp** = Enabled

With operation via terminal strip: **Ramp sel 0** and **Ramp sel 1** were not assigned to digital inputs





---

***GE Industrial Systems***

*1501 Roanoke Boulevard, Suite 435  
Salem, VA 24153  
1-800-543-6196  
[www.GEindustrial.com](http://www.GEindustrial.com)*