

## 50GHz Interleaver

### Features:

- Wide passband and low dispersion
- Passively athermalized
- High isolation and low insertion loss
- Fully qualified to Telcordia 1209/1221
- Compact size
- RoHS compliance



The Finisar 50G Interleaver efficiently demultiplexes (or multiplexes) 50G spaced channels into two sets of 100G spaced channels, which is the best solution to upgrade the existing 100G spacing system and cost saving to the equipment manufacturer. This passively athermalized interleaver offers exceptional performance in an ultra-compact form factor.

### Specifications:

Parameter	Unit	Minimum	Typical	Maximum
Wavelength range	nm	1530.33 1570.41	C band L band	1562.23 1603.17
Channel spacing	nm		50GHz	
0.5 dB Passband relative to ITU grid*	GHz	± 10		
1 dB Passband relative to ITU grid*	GHz	± 11		
3 dB Passband relative to ITU grid*	GHz	± 15		
25dB Stopband relative to ITU grid*	GHz	± 10		
IL over passband*	dB			1.8
IL uniformity within port*	dB			0.5
IL uniformity all ports*	dB			0.8
IL ripple over passband*	dB			0.5
Isolation over stopband*	dB	25		
Polarization dependent loss* (PDL)	dB			0.5
Polarization mode dispersion (PMD)	ps			0.2
Dispersion over passband	ps/nm	-30		+30
Return loss	dB	40		
Directivity	dB	50		
Optical power handling	mW	500		
Connector type	-	SC/PC or LC/PC, others upon request		
Pigtail length	m	1.0±0.1, others upon request		
Operating temperature range	°C	-5		+70
Dimensions (L x W x H)	mm	113.5 x 18 x 14 or 120 x 90 x 16		

\*Over all operating temperatures

## Package Dimensions: (Unit: mm)

### Package-1

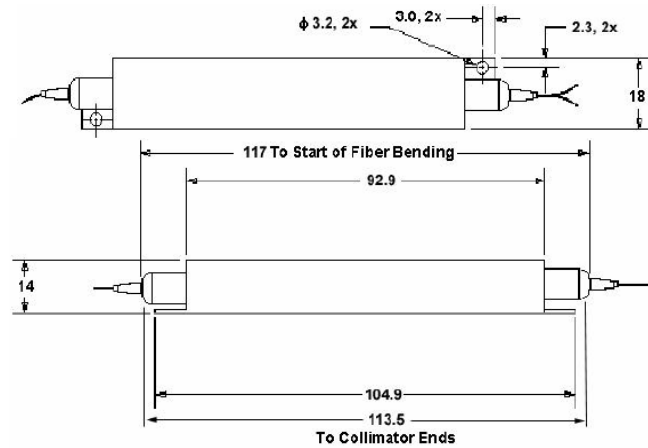

### Package-2

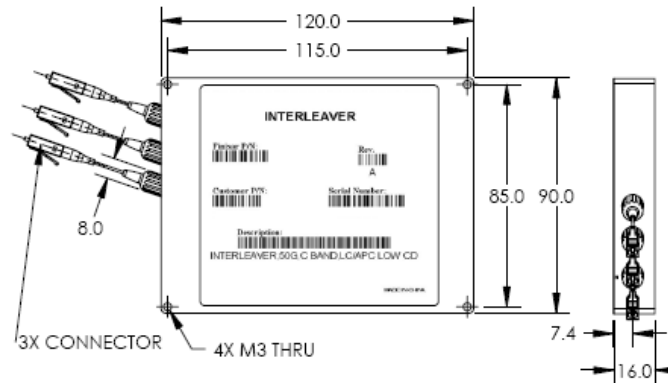

## Definition of the Optical Parameters:

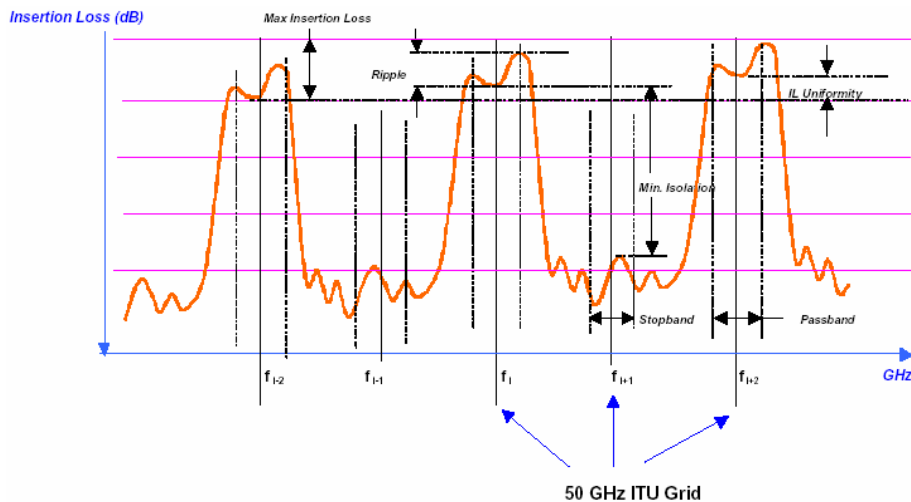

## Ordering Information

### Part Number Description

Part Number	Description
FINF050-100CLA1	50/100GHZ interleaver, C band, package size 113.5mmx18mmx14mm, SC/PC connector
FINF050-100CLA2	50/100GHZ interleaver, C band, package size 113.5mmx18mmx14mm, LC/PC connector
FINF050-100CLB1	50/100GHZ interleaver, C band, package size 120mmx90mmx16mm, SC/PC connector
FINF050-100CLB2	50/100GHZ interleaver, C band, package size 120mmx90mmx16mm, LC/PC connector