



The Leader in Event Critical Timing Electronics

# *Model 3220 Series Timer SBD*



# *Soap Box Derby Finish Differential & ET Timer Owner's Manual*

Rev M

**RaceAmerica Corporation  
P.O. Box 3469  
Santa Clara, CA 95055-3469  
USA  
(408) 988-6188  
<http://www.raceamerica.com>  
[info@raceamerica.com](mailto:info@raceamerica.com)**

Copyright 2008 RaceAmerica Corporation.

## Table of Contents

LIMITED WARRANTY.....	3
PACKAGE COMPONENTS .....	4
POWER REQUIREMENTS.....	4
PRODUCT SPECIFICATIONS.....	4
AVAILABLE OPTIONS.....	4
THEORY OF OPERATION .....	4
SET-UP STEPS - 3220 SERIES .....	5
Cabling Diagram.....	5
Power On/Self-Test.....	5
Alignment Mode .....	6
Configuration .....	7
TIMING A RUN .....	7
Finish Differential.....	7
Finish Differential plus Elapsed Time .....	8
Abort a run .....	8
Options.....	8
Elapsed Time (ET) .....	8
Adding Win Lane Lights.....	8
Printing a Timeslip.....	8
Adding Elapsed Time.....	9
Adding a Scoreboard.....	9
PC Software .....	9
MAINTENANCE .....	9
SPARE PARTS.....	9
SUPPORT AGREEMENTS.....	10
WIN LIGHT ASSEMBLY INSTRUCTIONS .....	10
FOAM STAND ASSEMBLY .....	11
TIMESLIP HEADER WORKSHEET.....	12

# RACEAMERICA

*T i m i n g   S y s t e m s*

---

## LIMITED WARRANTY

---

To the original purchaser of this RaceAmerica product, RaceAmerica warrants it to be in good working order for a period of ninety (90) days from the date of purchase from RaceAmerica or an authorized RaceAmerica distributor. Should this product malfunction during the warranty period, RaceAmerica will, at its option, repair or replace it at no charge, provided the product has not been subjected to misuse, abuse, or alterations, modifications, and/or repairs not authorized by RaceAmerica.

Any product requiring Limited Warranty service during the warranty period should be returned to RaceAmerica with proof of purchase. If return of merchandise is by mail, the customer agrees to insure the product, prepay shipping charges, and ship the product to RaceAmerica, Inc., 280 Martin Avenue Unit 1, Santa Clara, CA 95050.

ALL EXPRESSED AND IMPLIED WARRANTIES FOR THIS PRODUCT ARE LIMITED IN DURATION TO THE ABOVE NINETY DAY PERIOD.

UNDER NO CIRCUMSTANCES WILL RACEAMERICA BE LIABLE TO THE USER FOR DAMAGES, INCLUDING ANY LOST PROFITS, LOST SAVINGS, OR OTHER INCIDENTAL OR CONSEQUENTIAL DAMAGES ARISING OUT OF THE USE OF, OR INABILITY TO USE, SUCH PRODUCT.

THIS WARRANTY GIVES YOU SPECIFIC LEGAL RIGHTS, AND YOU MAY ALSO HAVE OTHER RIGHTS WHICH MAY VARY FROM STATE TO STATE.

## PACKAGE COMPONENTS

Each 3220 Series Timer SBD timing system package includes:

- 1 - 3220D Series Console Unit
- 1 - IR Beam Emitter Model 5042
- 2 - IR Track Sensors Model 5140
- 1 - Interconnect Cable Assembly for Track Sensors & Win Lights (option)
- 3 - Foam Stands (7540)
- 1 - 12VDC Power Patch Cord
- 1 - Owners Manual

## POWER REQUIREMENTS

You will need these additional items to operate your 3220 Series timing system:

- 1 - 12VDC automotive battery for Console
- 4 - 'C' batteries for Beam Emitter

**NOTE: Operating the timer from a battery connected to a charger or running car will result in an over voltage condition and damage the timer.**

## PRODUCT SPECIFICATIONS

The following listing provides the designed performance specifications for the 3220 Series timing systems:

Lane Width	4 to 50 Feet
Differential Capacity	up to 900.000 sec
ET Capacity	up to 900.000 sec
Time Accuracy	0.001 seconds

## Model 3220 AVAILABLE OPTIONS

- 6220B Winning Lane Lights (qty 2)
- 6038S Dot-Matrix Timeslip Printer
- 6560/6860 Large Display (Win Lane/Delta) and or Elapsed Time (ET)
- 06-S101 1000' Start Cable/Switch
- 06-S102 1000' Start Cable/Sensor/Emitter
- 4500B Data Communication PODs (for peripherals >100ft - 2 req'd)
- 4520A/B Wireless RF Links (2 req'd)

- 6070B Carry/Storage Case
- 6502A AC Power Adapter
- 3120A AXWARE Derby Software
- 3120B AXWARE Derby + Race Management S/W
- 3120C AXWARE Derby + Race Management (AASBD) S/W

## THEORY OF OPERATION

The 3220 Series Timers are completely self contained race timing systems made with CMOS circuit components to provide a highly accurate timing solution. The system contains an internal quartz crystal clock for time accuracy and display of race results to one thousandth of a second.

Power is supplied to the timer console and track sensor components of the 3220 by the 12VDC automotive battery connected to the RED and BLACK alligator clips, cigarette lighter adapter, or an AC adapter. An absolute minimum of 11.0VDC is required for reliable operation of the system. Under normal conditions, charged batteries will operate for days without a recharge.

The Beam Emitters and Track Sensors operate on invisible (to the unaided human eye) Infra Red light. The coded light frequencies are constantly received by the Track Sensors until a car interrupts reception ('breaks' the beam).

The IR Beam Emitter to Track Sensor transmission operates on Line-of-Sight principles. This makes alignment of these units critical. Tips are provided to aid alignment on surfaces that are other than ideal. These units will operate over a wide range of conditions but should not be operated beyond the specification parameters (less than 4 ft or more than 50 ft).

Once the system is properly set up and aligned, the timer console will 'monitor' the track sensors each time a run is made.



## SET-UP STEPS - 3220 SERIES

### STEP 1 -

Familiarize yourself with the components pictured in this manual and how they interconnect. The Track Sensor Interconnect Cable is configured for connection between the a Sensors, Win Lights and timer console at the finish line with a tail for a Start Sensor.

All connectors are keyed for proper orientation. The 12VDC battery is connected with the RED alligator clip to plus (+) terminal of the battery and the BLACK alligator clip to (-) terminal of the battery.

The free standing, battery powered Model 5042 IR Beam Emitter is placed on the centerline of the track at the finish line and the Model 5140 IR Track Sensors are placed on the outsides at the finish line. The Track Sensor units are interchangeable with each other. The Track Sensor Cable is keyed to match the Lane 1 and Lane 2 track sensor positions and marked at the end of the cable (see cable diagram)

### STEP 2 -

Identify the emitter/sensor placement at the finish line. The lane width should be set between four (4) and fifty (50) feet. To help in determining initial Beam Emitter to Track Sensor alignment in larger track widths, use a string stretched between the beam emitter and track sensor or eyeball a straight line between units.

Picture shows one unit from the top and one unit from the bottom.



Model 5042  
IR Beam Emitter



Model 5140  
IR Track Sensor

#### Model 5042 - IR Beam Emitter

The unit contains two Emitter units facing opposite directions, powered by 4 'C' batteries. When connected to the batteries, the Emitter is ON. Place the battery pack in the bottom of the Foam Stand.

#### Model 5140 - IR Track Sensor

Note cable connector is located in the side facing away from the track. All Track Sensor are fully interchangeable with one another. Track Sensor is pictured both top and bottom sides up.

### STEP 3 -

Layout the Track Sensor Interconnect Cables on the track site (see cable diagram). The large round connector connects to the console and the two smaller connectors (RJ11) connect to the Track Sensors at the finish line as indicated on the cable near the RJ11 connector. Install the Emitter and Sensors in the Foam Stands; connect the

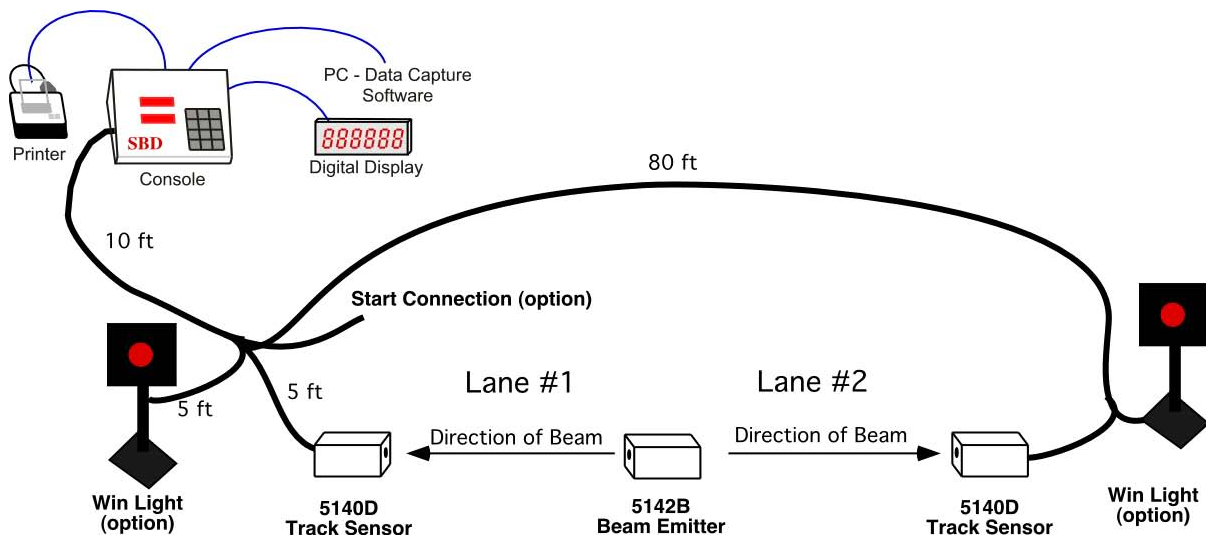

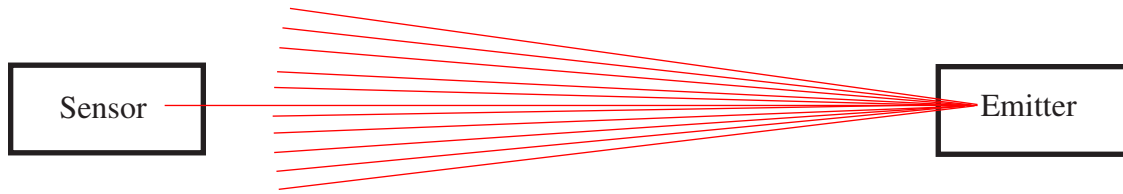

The Emitter throws a spot light like beam of infrared light; the Sensor should be aligned near the center of the beam for optimal reception and alignment.

Interconnect Cable to the Timer Console and the Track Sensors through the opening in the back of the Foam Stand. If adding the ET option, see instructions for this option in the options section.

#### STEP 4 -

Cable tails are available to connect optional Win Lights and Elapsed Time (ET) detection if available. Install other purchased options per the instructions in their respective section and manuals.

#### STEP 5 -

Connect the RED (+) and BLACK (-) alligator clips to the 12VDC battery and you're ready to begin.

#### POWER ON/SELF-TEST

Connecting the 12VDC battery to the System Console places the RaceAmerica 3220 Series Timer into a self-test of the microprocessor circuitry and the LED (Light Emitting Diode) display. This is an internal test as well as a visual check of the LED display. The LED Displays progressively sequence the digit '8' through each segment of all digits and then progressively turns them off; then the upper display shows [**LANE 1**] (and illuminates the Lane 1 Win Light if it is connected); then the display shows [**LANE 2**] (and illuminates the Lane 2 Win Light if it is connected); finally, the upper console display shows the product model number [ **3220** ] and the lower display shows the code revision level [**C.00.0**] contained within the microprocessor.

#### ALIGNMENT MODE

All RaceAmerica timing systems have an alignment mode. This is very useful for verifying correct Emitter/Sensor alignment. After the track layout has been determined and the Sensors and Emitters placed in the proper positions, press the [**5**] **ALIGN** key to enter alignment mode. The LED Display shows [**ALIgn**] in the upper display and briefly [**-S-1-2**] in the lower display. The digits indicate Start, Lane 1, Lane 2 respectively. The Status Display then changes each digit to a zero for each sensor being monitored [**-0-0-0**]. If the Beam Emitter and Track Sensor are operating properly and aligned, the '0' digit will not change. If the Beam Emitter and Track Sensor are not properly aligned, the 0 digit for each emitter/sensor pair will count slowly if slightly out of alignment or continuously if they are not functioning properly or way out of alignment. Once the emitter/sensor pair are aligned properly, the digit will stop counting. If the alignment is off a little or intermittent, the digit for that emitter/sensor pair will count when they float out of alignment. Remember, the Beam Emitters and Track Sensors operate on a 'Line-of-Sight' concept and may require shims if they are installed on a surface with a crown. Leaves, people, and other debris will also break the beams and could give false signals, so keep everyone and everything clear of the Beam Emitters and Track Sensors during racing activity.

To maximize the alignment of the emitter/sensor pairs, it is suggested to rotate the Beam Emitter slowly left and right until the alignment for that pair begins to count. This technique will determine the maximum lateral detection angle. Rotating the Beam Emitter up and down

until the alignment starts counting determines the maximum vertical detection angle. Once these extremes are established, position the Beam Emitter in the center of the left/right detection angle and up/down detection angle. Repeat this same process with the Track Sensors. This will maximize the alignment accuracy. It should also be noted that once the zero digit has started counting, it will never stop at zero again unless Alignment Mode is exited and reentered. This can be helpful for leaving the system in alignment mode for an extended period of time to check on an intermittent condition.

If the Start Sensor (or switch) is not connected, the 'S' position will be counting. To run a race without Start, make sure the ET option is disabled in the configuration mode.

At this point the system is properly aligned. Press the [#] ENTER button to exit Alignment Mode.

## CONFIGURATION

The SBD Timer ships with the following factory default settings:

Printer Port	Print
Auto Print Timeslip	1
Print Line Feeds	12
Print Header	Generic
ET Option	OFF

If any of these settings need to be changed, press the [8] CONFIG key on the Keypad to



enter the system configuration mode, the console displays [-Port-] [-Print] which sends timeslip data to the printer port. Repeated presses of the [#] ENTER key cycle the lower display to **Display** [-diSP-] which will send ET times to scoreboards. Press the [8] CONFIG key to accept the desired condition. If Print was selected, the display will show [LF] [ 12 ] (Upper/Lower displays) and the user is prompted for the number of line feeds (blinking digit) to add to the end of the timeslip to properly eject the timeslip for tearoff. Enter the number of line feeds required and press the [#] ENTER key to confirm. Next [AutoPr] [1] will show the number of timeslip copies to automatically print each time a race ends; press a number on the keypad (1-9) for desired number of copies; press [#] ENTER to exit Config mode. Each time a change is made to the config, the display will show [ConFiG] [StorEd] when exiting config mode.

With the Printer Port configured to print, press [8] [CONFIG] three times to display [ConFiG] [HEAdEr]. See page 12 for setup worksheet. Press # [ENTER] to view the setup dialog as follows [L1 C01] [XX00] indicating Line 1 Character 01; the XX is prompting for the character code for the desired character; refer to the worksheet for the correct code, press [#] to move to character 02 [L1 C02] [YYXX00] where YY is Character 01 and XX is prompting for character 02, the last two digits are the current code for the next digit (3rd in this case); continue for up to all 39 characters in the line. Press [\*] to move to Line 2 [L2 C01] [ XX00] and continue for all four lines. When done with all four lines, press [\*] to exit Config mode.

Press [8] [CONFIG] four times to set the Elapsed Time function. The Display will show [--Et--] [--OFF-] which tells the system no Start Sensor is connected and no ET will be reported. Repeated presses of the [#] ENTER key cycle the lower display to **ON** [on]. If the ET option is present, select ON; press the [8] CONFIG key to exit Config mode. These parameters can be reconfigured at any time. The configuration parameters are stored until they are changed (including power off).

## TIMING A RUN - Finish Differential

Before timing a run, it may be desirable to enter the racer numbers so they will appear on the printout. To enter a racer number, press the **[9] CAR#** button on the keypad to view the existing entries; press **[9]** again to enter new numbers; press **[#] ENTER** to accept the entries.

To time a run, press the **[2] RESET** button. The timer immediately checks all track sensors to insure they are operating and aligned properly. The timer performs this function automatically while displaying **[rESEt]** in the upper display and 1 to 6 dashes **[-----]** on the lower LED display. If a sensor fails the alignment test by triggering during this test, the timer will indicate **[-FAiL-] [-S-1-2]** with the misaligned sensor(s) blinking. If Lane 1 and Lane 2 sensor/emitter pairs are aligned, the LED display will display **[rEAdy]** when it is ready to time a run. Once a sensor is triggered, the display will show **[LAnE X]** (illuminate the Win Light) in the upper display and will count the difference in the lower display until the other lane's sensor is triggered. At this point the LED display displays **[LAnE-X] [XXX.XXX]** indicating the winning lane and the differential in the upper/lower displays respectively. If a printer, PC or Digital Display is connected, the output will be sent to these devices at the end of the race. To resend the data, press the **[0] PRINT** button. Press **[#] ENTER** to blank the display. To review the result before another race has begun, press **[4] DELTA**. To reset for the next run, press the **[2] RESET** button. If **[0] PRINT** is pressed and the port is configured for a display, the console display will show **[no] [Print]**.

If a Fail condition is detected, press **[5] ALIGN** or **[#] ENTER** to go to alignment mode to correct the bad alignment, press **[#] ENTER** to leave alignment mode.

If the Start Sensor/Switch is not connected, ET timing must be **OFF** in the **CONFIG** menu.

### TIMING A RUN Finish Differential + ET

Before timing a run, it may be desirable to enter the racer numbers so they will appear on the

printout and in the data transmitted to PC capture software. To enter a racer number, press the **[9] CAR#** button on the keypad to view the existing entries; press **[9]** again to enter new numbers; press **[#] ENTER** to accept the entries. Make sure the ET option is ON in the CONFIG menu.

To time a run, press the **[2] RESET** button. The timer immediately checks all track sensors to insure they are operating and aligned properly. The timer performs this function automatically while displaying **[rESEt]** in the upper display and 1 to 6 dashes **[-----]** on the lower display. If a sensor fails the alignment test by triggering during this test, the timer will indicate **[-FAiL-] [-S-1-2]** with the misaligned sensor(s) blinking. If all sensor/emitter pairs are aligned, the LED display will display **[rEAdy]** when it is ready to time a run. Once a sensor is triggered, the display will show **[LAnE X]** (illuminate the Win Light) in the upper display and will count the difference in the lower display until the other lane's sensor is triggered. Then the timer will switch to display **[LAnE-X] [XXX.XXX]** indicating the winning lane and the differential in the upper/lower displays respectively. If a printer, PC or Digital Display is connected, the output will be sent to these devices at the end of the race. To resend the data, press the **[0] PRINT** button. Press **[#] ENTER** to blank the display. To review the results before another race has begun, press **[1] ET** or **[4] DELTA**. To reset for the next run, press the **[2] RESET** button.

If a Fail condition is detected, press **[5] ALIGN** or **[#] ENTER** to go to alignment mode to correct the bad alignment, press **[#] ENTER** to leave alignment mode.

### ABORT A RUN PRIOR TO FINISH

To stop the timer during a run or if only one racer finishes (bye-run), press the **[#] ENTER** button and the timer will show **[Abort] [run]** in the upper/lower displays; press **[#] ENTER** again to clear the displays. Available data will be sent to printers, PCs and ET displays



## SYSTEM OPTIONS

Several options (Elapsed Time (ET), Printer, Digital Display or PC) can be connected by a RS232 cable connection up to 100 feet or by a Wireless Link for greater distances (line of sight up to a quarter mile). Connectors are on the underside of the console.

### ELAPSED TIME OPTION

The Elapsed Time option involves running a cable to the starting line connected to the RaceAmerica starting line connector in the wiring harness. A RaceAmerica sensor can be connected to the cable to optically start both lanes Elapsed Times. Alternately, the 4-conductor connector for the starting line has contacts numbered 1 thru 4 as follows so a mechanical switch can be connected:

- Pin 1 - POWER
- Pin 2 - START SIGNAL
- Pin 3 - not connected
- Pin 4 - GROUND

Wire a normally closed switch between pins 2 and 4. When starting, the switch should open to trigger the timer to start timing the ET's for both lanes. It does not matter if the switch remains open or closed but must be closed for the start of the next race.

### WIN LIGHTS OPTION

The Win Lights connect to the RJ45 connector tails on the cable at the finish line. The light for the first lane to finish will illuminate and flash. Win Lights are powered from the console. See the section on Win Light assembly at the end of the manual.

## PRINTER OPTION

Connect the timeslip printer interface cable to the 3220 Timer SBD using the PRINTER PORT on the console. The 3220 will auto print the designated number of timeslips after each race. Additional copies can be printed by pressing the **[0] PRINT** button before the timer is reset. The print function is disabled if the timer is timing a run.

The timeslip header can be user configured (up to four lines of 39 characters each) for each event, club, date or whatever. See page 12 for a worksheet to layout the print header.

## SCOREBOARD OPTIONS

The Timer SBD can be connected to a large display scoreboard to display race results for a crowd and the competitors. Connect the model 6560/6860 Large Digital Display to view Winning Lane and time differential immediately upon completion of each timed even. Alternately, connect two displays to show the Elapsed Time for each lane (the Printer port can be reconfigured for Display). Use the DIP switches to select display format (Winning lane + Differential, Lane 1 ET, or Lane 2 ET).

## ADDING PC SOFTWARE

RaceAmerica is pleased to offer the full line of AXWARE Derby third party software for the PC (Windows 95 or later Operating System) to capture the times and build a file with racers names and race results. Three options are available to capture data and manage your race day matchups including AASBD formats.

## MAINTENANCE

The 3220 Series Console, Beam Emitter, and Track Sensors do not require any maintenance.

To insure uninterrupted operation on raceday, it is suggested to keep track of battery usage hours so as to have fully charged batteries. Plan to replace the 'C' cells in the Beam Emitter after about 200 hours use. If you are using rechargeable 'C' cells, recharge them each day. Low battery voltage (Emitter voltage below 4.3VDC) will cause intermittent operation of the system resulting in intermittent events at the finish line as the battery power weakens.

To maintain the highest level of timing accuracy and minimize false trips, annual preventative maintenance and calibration should be performed on all system track sensors and beam emitter units.

## SPARE PARTS

Further to minimize race program interruptions, RaceAmerica recommends some spare parts. A spare emitter/sensor pair and end of track cable sections should be available in the event of an unfortunate accident during a program. Contact RaceAmerica for availability and pricing of spares items.

## SUPPORT AGREEMENTS

Support agreements are available from RaceAmerica providing Telephone Assistance on technical issues and operational questions, repair and/or replacement of hardware failures, Software and Firmware updates and bug reporting, and Annual Preventative Maintenance on all system track sensors and beam emitter units. Contact RaceAmerica for more information and pricing of Support Agreements.

## WIN LIGHT ASSEMBLY

The win lights are assembled by screwing the post into the base and then attaching the Win Light with a 1/4-20 bolt at the top of the post - connector down. The connector on the win light assembly connects into the interconnect cable's matching connector.



## 7540C - Foam Stand Assembly Instructions

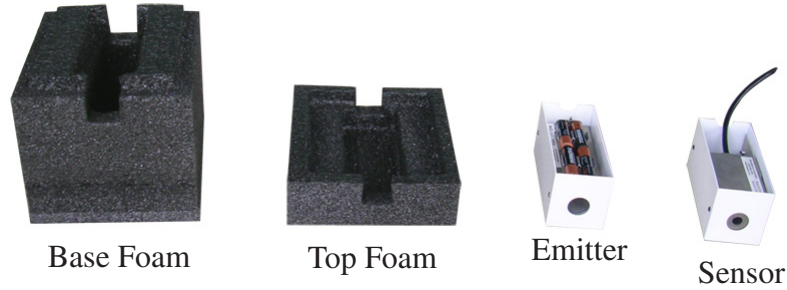

Assembly Components

### 'AA' Battery Emitter (5040B, 5050B & 5058B)

1. Install batteries and turn on the Emitter.
2. Separate the Base of the Foam Stand from the Top.
3. Place the 5040/5050/5058 Emitter into the Base foam with the battery side down.
4. Slide the Top on the Base. Place on the track.



Sensor/Emitter placement in Foam Base

### Track Sensor (5140D & 5158D)

1. Separate the Base of the Foam Stand from the Top.
2. Connect the cable to the sensor
3. Place the 5140/5158 Sensor into the base (open end down)
4. Press the Top on the Base. Place on the track.



Sensor back  
Note cable routing

### 'C' Battery Emitter (5042B)

1. Same as above except place the 'C' Battery pack in the Base standing on its edge.

For additional stability

1. Place weight in the Base well as required.

Outside Dimensions:

6.5" W x 7.25" L x 7.5" H



Complete Assembly

## TIMESLIP HEADER

The 3220 Console allows custom timeslip header input for four lines of up to 39 characters each to print at the top of each timeslip. Input for the Timeslip Header is found in the **[ConFig]** **[HEAdEr]** menu. Once the configuration is input, it is saved until changed or deleted. Input is from the keypad via a two-digit code for each character. The console display prompts for each line, character and character code (existing or new) being input.

The following table lists the codes for each character (note: upper and lower case letters have different codes). Use the worksheet on the next page to lay out the desired print text and cross-reference the codes for sequential input. Only desired text including spaces need to be input for each line; any line or lines can be left blank also.

Character	Code	Character	Code	Character	Code
Space	00	A	33	a	65
!	01	B	34	b	66
@	02	C	35	c	67
#	03	D	36	d	68
\$	04	E	37	e	69
%	05	F	38	f	70
&	06	G	39	g	71
'	07	H	40	h	72
(	08	I	41	i	73
)	09	J	42	j	74
*	10	K	43	k	75
+	11	L	44	l	76
'	12	M	45	m	77
-	13	N	46	n	78
.	14	O	47	o	79
/	15	P	48	p	80
0	16	Q	49	q	81
1	17	R	50	r	82
2	18	S	51	s	83
3	19	T	52	t	84
4	20	U	53	u	85
5	21	V	54	v	86
6	22	W	55	w	87
7	23	X	56	x	88
8	24	Y	57	y	89
9	25	Z	58	z	90
:	26	[	59	{	91
;	27	v	60		92
<	28		61	}	93
=	29	]	62	~	94
>	30	_	63		
?	31	'	64		
@	32				

**TIMESLIP LAYOUT WORKSHEET**

Character Position	1	2	3	4	5	6	7	8	9	10	11	12	13	14	15	16	17	18	19	20	21	22	23	24	25	26	27	28	29	30	31	32	33	34	35	36	37	38	39		
Printed Character																																									
Character Code																																									
Printed Character																																									
Character Code																																									
Printed Character																																									
Character Code																																									
Printed Character																																									
Character Code																																									
Printed Character																																									
Character Code																																									

Line 1  
Line 2  
Line 3  
Line 4

Timeslip Header Character Code Worksheet