



WARNING:

This Product has a maximum user weight limitation of 300 lbs.

Drive Medical assumes no responsibility for any damage or injury caused by improper installations, assembly, or use of this product.

If components are missing or damaged, please contact your dealer immediately. DO NOT use substitute parts!

NOTE:

Do not use the chair until all the assembly steps have been completed

Warranty:

- Limited lifetime on the frame and 1 year on upholstery

MAINTENANCE

Check all hardware periodically for tightness

lifetime limited warranty

Your Drive brand product is warranted to be free of defects in materials and workmanship for the lifetime of the original consumer purchaser.

This device was built to exacting standards and carefully inspected prior to shipment. This Lifetime Limited Warranty is an expression of our confidence in the materials and workmanship of our products and our assurance to the consumer of years of dependable service.

In the event of a defect covered by this warranty, we will, at our option, repair or replace the device.

This warranty does not cover device failure due to owner misuse or negligence, or normal wear and tear. The warranty does not extend to non-durable components, such as rubber accessories, casters, and grips, which are subject to normal wear and need periodic replacement.

If you have a question about your Drive device or this warranty, please contact an authorized Drive dealer.



© 2005 Medical Depot, Inc. All rights reserved.
Drive is a trademark of Medical Depot, Inc.
Port Washington N.Y. 11050 USA Made in China

steel hip-high chair



EU Authorized Representative
Drive Medical LTD
Ainley's Industrial Estate
Elland, West Yorkshire,
United Kingdom HX5 9JP

www.drivemedical.com

drive
MEDICAL DESIGN & MANUFACTURING

assembly instructions

1. Remove contents from box: 8 large frame screws and bolts, 4 seat screws, 4 backrest screws, 2 arm frames, a footrest frame, and a seat frame.
2. Using screws and nuts marked "A" attach footrest to arm frame by inserting screw from the outside of frame. Secure using one of the nuts. Tighten using a phillips head screwdriver and wrench. Be sure that the front of the armrest corresponds to the front of the footrest (Figure 1).
3. Attach seat frame to arm frame using screws and bolts marked "A". Tighten using a phillips head screwdriver and wrench. (Figure1).
4. Attach second arm frame section to footrest frame and seat frame using the same process. (Figure 2)
5. Attach padded seat to seat frame using screws marked "B" and the large diameter allen key. Note: the seat is the square padded piece. (Figure 3)
6. Attach padded backrest to frame using the screws marked "C" and the small allen key. (Figure 4)
Note: the backrest is the slightly tapered piece. It should be placed on the frame so the smaller side is at the top.
7. Make sure all screws are tightened before use.

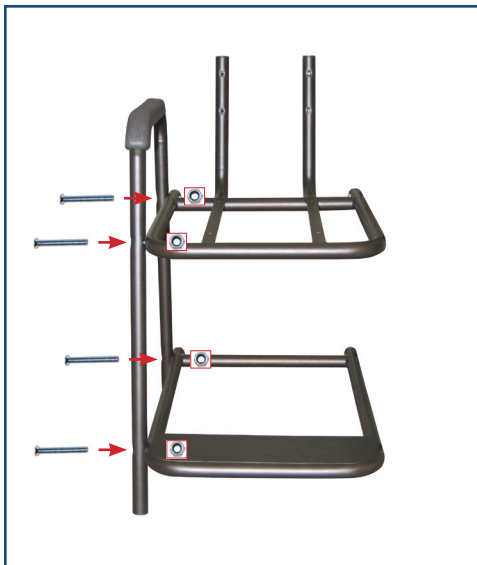
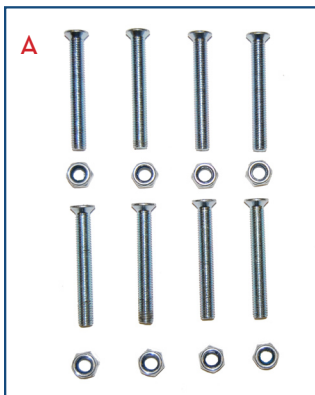

figure 1

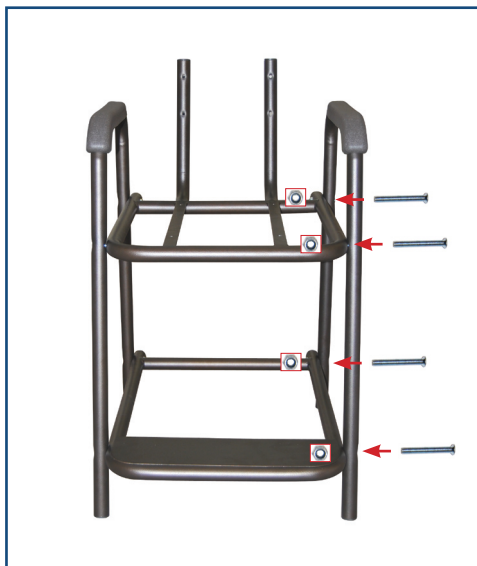

figure 2



figure 3



figure 4