



# **A&E CATALINA 2500™**

by Dometic

**USA**  
**Service Office**  
The Dometic Corp.  
509 South Poplar St.  
LaGrange, IN 46761

**CANADA**  
Dometic Dist.  
866 Langs Dr.  
Cambridge, Ontario  
CANADA N3H 2N7



## **INSTALLATION & OPERATING INSTRUCTIONS**

**Catalina  
2500**

**REVISION**  
Form No. 3103624.023 3/98  
(Replaces 3103624.015)  
(French 3108310.024)  
©1998 The Dometic Corporation  
LaGrange, IN 46761

# A&E CATALINA 2500

## INSTALLATION/OPERATION

### APPLICATION

The A&E Catalina 2500 Case Awning is designed and intended for direct mounting on straight and most curved mini-motorhomes, pick-up campers, vans, van conversions and pop-up tent trailers.

The optional Universal Van Adapter Kit, A&E Part No. 930035 allows permanent or temporary mounting to vans with rain gutters without drilling holes in the van.

**Important: Read the entire installation procedure before starting installation.**

Note: The Dometic Corporation assumes no liability for damages or injuries resulting from installation or operation of this product.

The Dometic Corporation reserves the right to modify appearances and specifications without notice.

### INSTALLATION

#### Tools Required:

- Measuring Tape
- Electric Drill
- Drill Bits #8 or 3/6", 1/8"
- Center Punch
- Phillips Screw Driver
- Pencil
- Pop Rivet Gun (Necessary only if Backing Plate is needed)
- Silicone Sealant

#### For Direct Wall Mounting:

**Note:** When determining location for awning make sure to consider door clearance, if required, and location of other vehicle components like compartment doors, mirrors, etc..

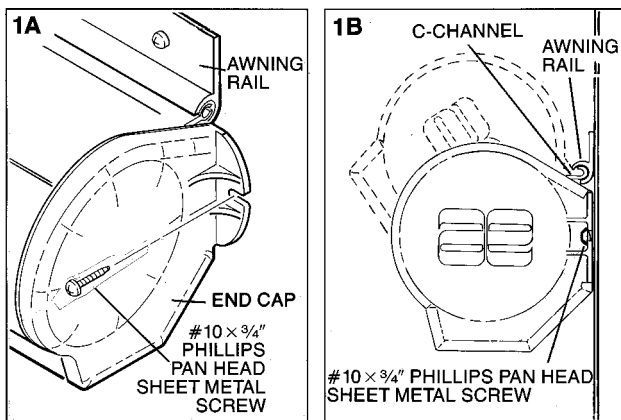

1. A. Install C-Channel of awning case into awning rail by inserting C-Channel into one end of awning rail and sliding awning case into position (FIG. 1A), or by tilting case up and inserting entire C-Channel into awning rail and rotating case down into position (FIG. 1B).
- B. Using the end caps as templates, drill one 1/8" Dia. hole into vehicle for each end cap (FIG. 1A). Secure each end cap using one #10 x 3/4" Phillips pan head sheet metal screw with a small dab of silicone sealant on each screw (FIG 1A & 1B).

**Note:** Awning must be mounted with case back parallel to side wall of vehicle.

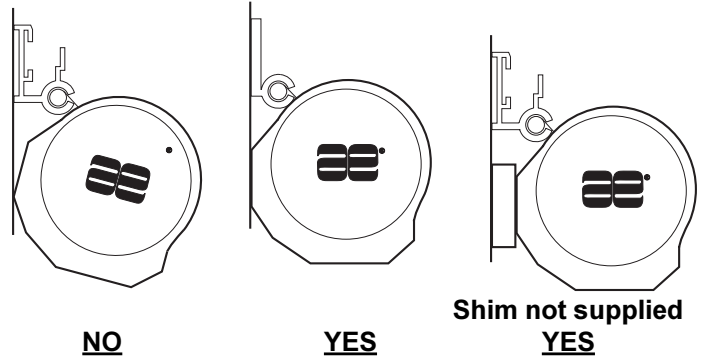

**Note:** Be sure to use a dab of silicone sealant on every screw where a hole has been drilled in the side of the vehicle. This will prevent possible water leakage.

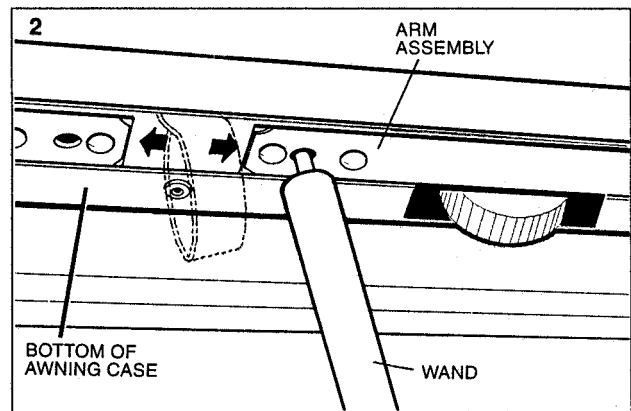

2. Using the wand, open awning case by inserting the pin on the end of the wand into hole in arm assembly indicated by arrows on bottom of case (FIG. 2)

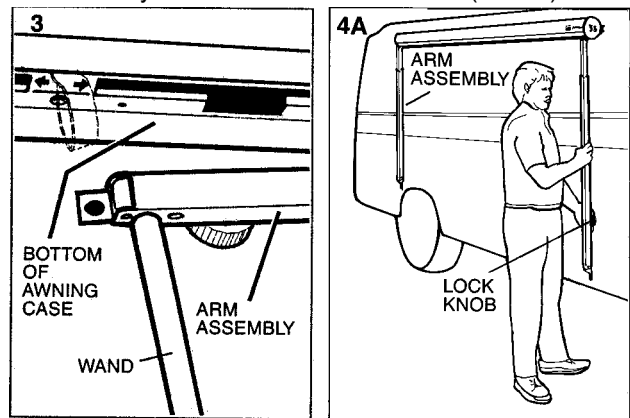

3. Lower arm assembly out of awning case (FIG. 3)
4. A. Allow arm to hang freely from case. Tighten lock knob (FIG. 4A). Repeat for other side.

**Note:** For curved sided vehicles proceed to Step 4B. For straight sided vehicles skip to Step 5.

- B. Lower arm assembly to ground. With foot still on ground raise inner arm as high as it will go (FIG. 4B).

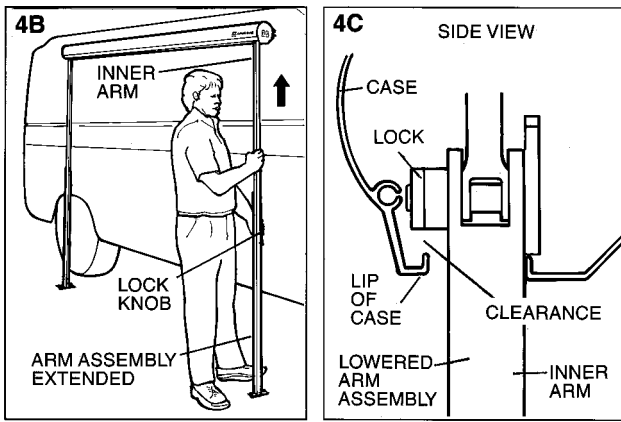

**Note:** Make sure lock in top of awning arm assembly clears top of case lip (FIG. 4C). This is necessary for awning to open properly.

Tighten lock knob. Repeat steps 4B & 4C for other side.

- C. Using wand, hook pull-strap and pull awning out about 3 feet (1 meter) (FIG. 4D).
- D. While securely holding the pull-strap, tighten the lock knobs on the rafter arms (FIG. 4E).

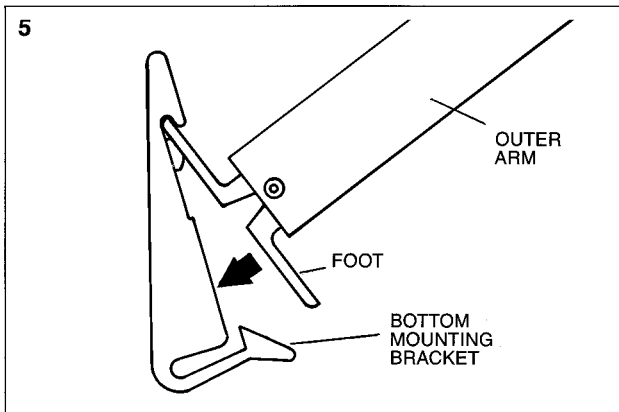

- 5. Snap awning foot into bottom mounting bracket (FIG.5).
- 6. Select a location for mounting of bottom mounting bracket on side of vehicle. The minimum mounting distance from the bottom of the awning case to the bottom of the bottom mounting bracket for the 2.5 meter awning is 48". For the 3.0, 3.5 and 4.0 meter awnings it is 58" (FIG. 6).

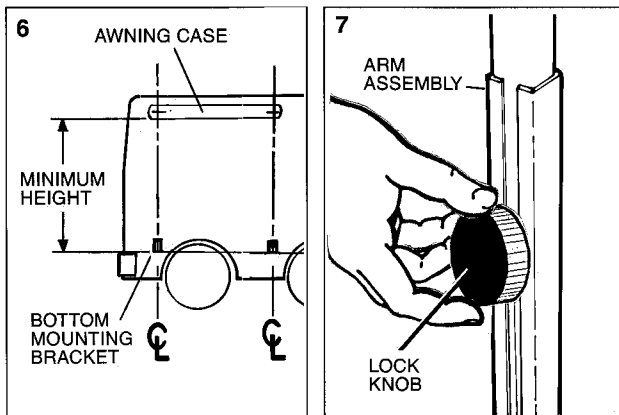

**Note:** Positioning of left and right bottom mounting brackets should be at same level and centered to the awning arms (FIG. 6).

- 7. Loosen lock knob and extend arm assembly keeping arm perpendicular to awning case. Once location is determined, tighten lock knob (FIG. 7).

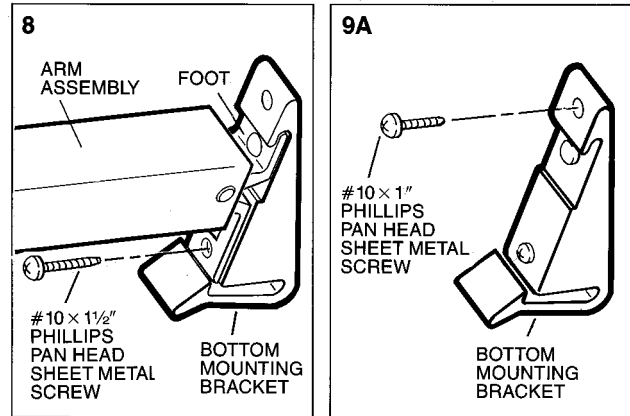

**Note:** The bottom mounting brackets should be mounted to the floorline of solid structural member whenever possible.

- 8. Using the foot and bottom mounting bracket as a template, drill a 1/8" dia. hole for the bottom screw. Secure bottom mounting bracket with foot attached to vehicle using a #10 x 1-1/2" long Phillips pan head sheet metal screw through the foot and the bottom mounting bracket. Use a small dab of silicone sealant on screw (FIG. 8)
- 9. A. Release foot from bottom mounting bracket and drill a 1/8" dia. hole for the top screw. Using a #10 x 1" long Phillips pan head sheet metal screw with a dab of silicone sealant on it, secure the top of the bottom mounting bracket to vehicle (FIG. 9A).

Repeat Steps 5 through 9A for other side.

**Note:** For curved sided vehicles proceed to Step 9B. For straight sided vehicles skip to Step 10.

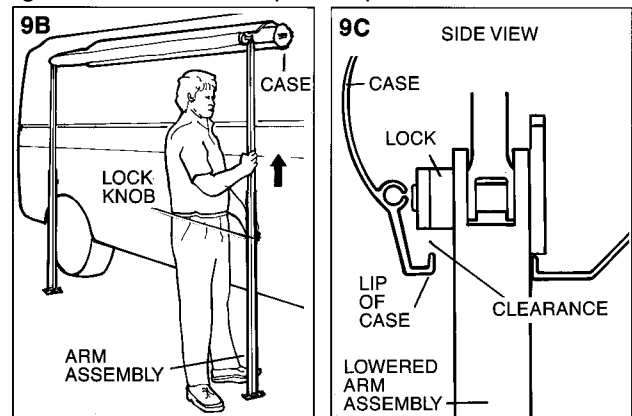

- B. Loosen lock knob and lower arm assembly to ground. With foot still on ground raise inner arm as high as it will go (FIG. 9B).

**Note:** Make sure lock in top of awning arm assembly clears top of case lip (FIG. 9C).

Tighten lock knob.

Repeat Step 9B for other side.

**Note:** For curved sided vehicles skip to Step 13.

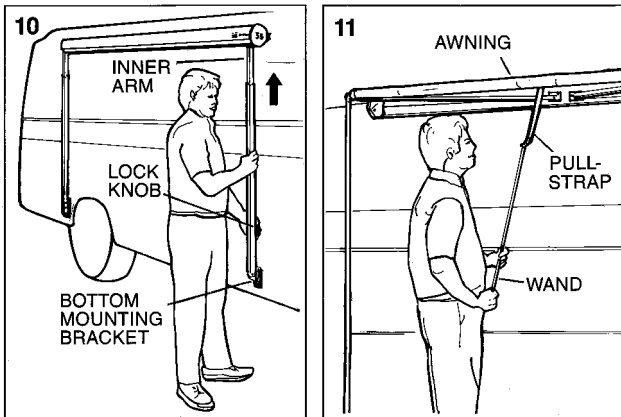

10. Reattach foot to bottom mounting bracket. Loosen lock knob on arm assembly. Raise inner arm as high as it will go. Then tighten lock knob (FIG. 10).

**Note:** Make sure lock in top of awning arm assembly clears top of case lip (FIG 9C). This is necessary for awning to open properly.

Repeat for other side.

11. Using wand, hook pull-strap and pull awning out about 3 feet (1 meter) (FIG. 11).

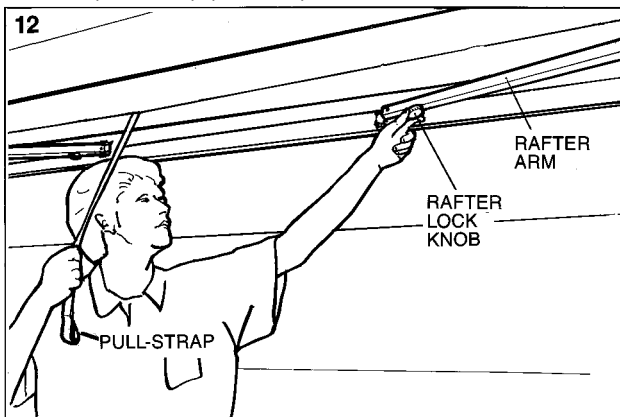

12. While securely holding the pull-strap, tighten the lock knobs on the rafter arms (FIG. 12).

13. A. On the back wall inside the awning case, measure in from edge of end cap 1 inch (2.54 cm) and up 1/2 inch (1.27 cm) from bottom edge of back wall as shown in FIG. 13 and mark this location.

B. Drill a 3/16" dia. hole through the back of the awning case and into the vehicle. Repeat for other side.

14. Secure case to vehicle using the two #14 Phillips pan head sheet metal screws provided with a small dab of silicone sealant on each screw (FIG. 14).

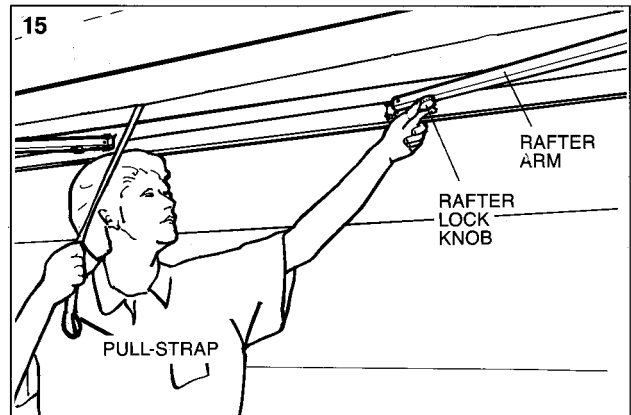

15. While holding pull-strap firmly, release lock knobs on rafter arms and allow awning to roll up (FIG. 15). Awning case should close tightly.

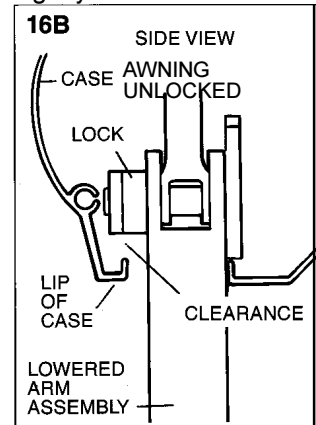
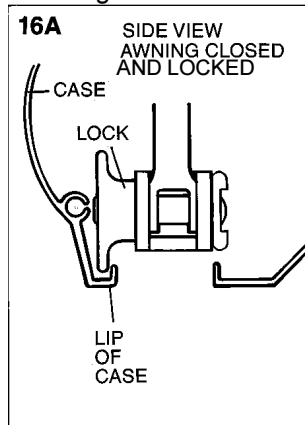

16. For correct installation, lock in top of awning arm assembly must engage case lip (FIGS. 16A and 16B).

**Note:** For proper operation it is very important for lock to clear top of case lip when opening and for lock to engage case lip when awning is closed.

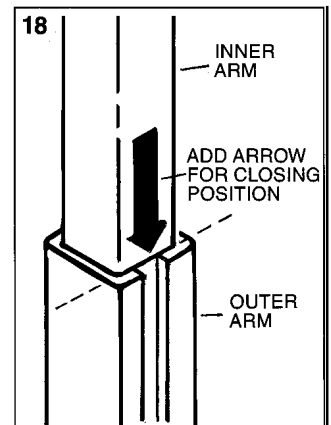
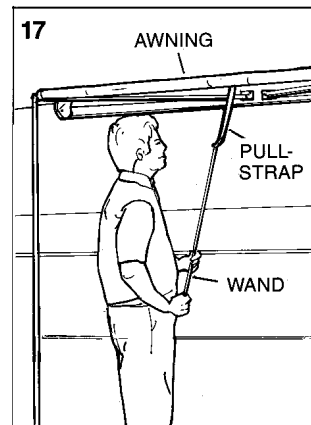
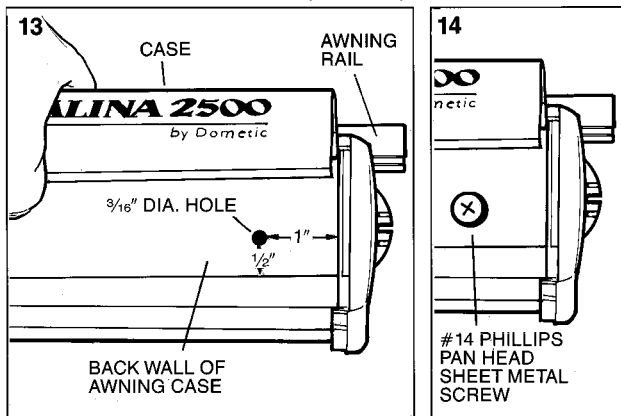

17. Using wand, check to see if awning opens and closes correctly by pulling awning out about 3 feet (1 meter) (FIG. 17).

**Note:** For installation on some curved sided vehicles Step 18 does not apply.

18. When awning is at proper setting and operates correctly, mark location of arm setting on inner arm assembly with supplied arrow labels (FIG. 18). Repeat for other side.

## OPERATION INSTRUCTIONS TO OPEN

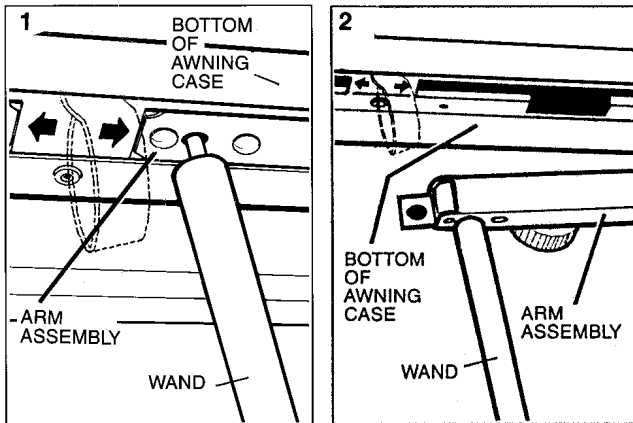

1. Using wand, open awning case by inserting pin on end of wand into hole in arm assembly indicated by arrows on bottom of case (FIG. 1).

2. Lower arm assembly out of awning case (FIG. 2).

**Note:** For curved sided vehicles proceed to Step 3. For straight sided vehicles skip to Step 4.

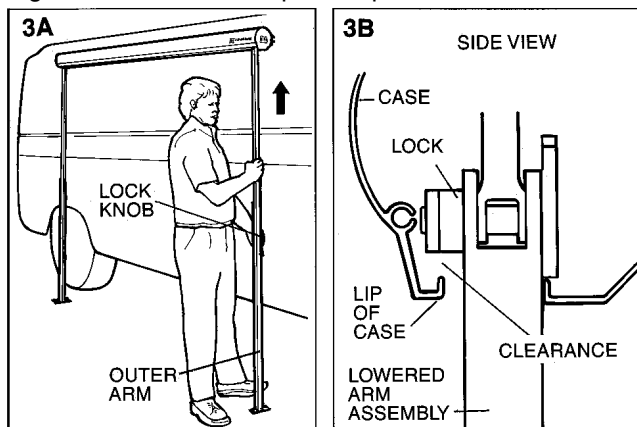

3. A. Slide outer arm down to ground. With foot still on ground, raise inner arm as high as it will go and tighten lock knob (FIG. 3A).

**Note:** Make sure lock in top of awning arm assembly clears top of case lip (FIG. 3B). This is necessary for awning to open properly.

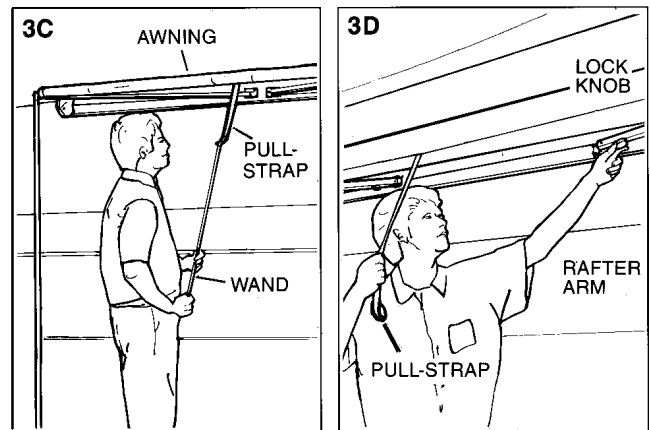

B. Using wand, hook pull-strap and pull awning out about 1 meter (3 feet) (FIG. 3C).

C. While securely holding the pull-strap, tighten the lock knobs on the rafter arms (FIG. 3D).

D. Set awning into pivot position by inserting the awning foot into the bottom mounting bracket (FIGS. 4A and 4B).

**Note:** For curved sided vehicles skip to Step 5.

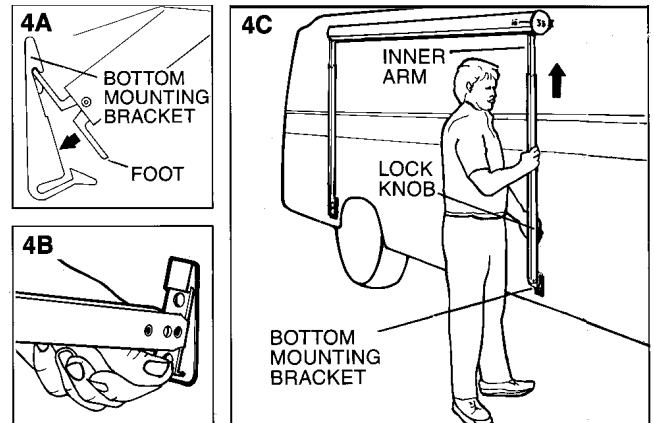

4. A. Set awning into pivot position by inserting the awning foot into the bottom mounting bracket (FIGS. 4A, 4B and 4C).

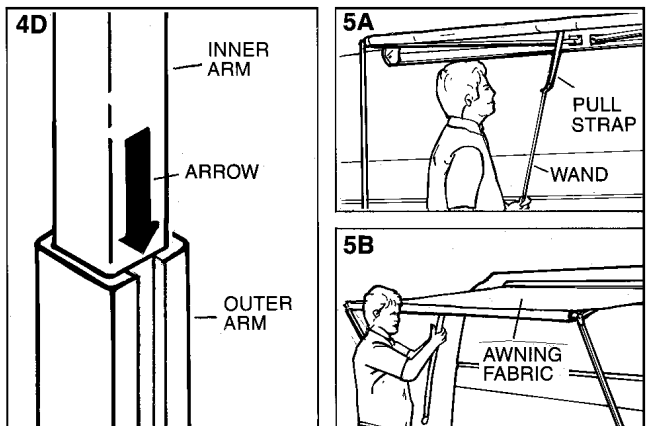

B. Extend arm assembly until arrow on inner arm lines up with outer arm (FIG. 4D). This allows lock in top of awning arm assembly to clear top of case lip (FIG. 3B).

**Note:** This is necessary for awning to open properly.

C. Tighten lock knob on arm assembly.

- Using wand, hook pull-strap and pull awning out by unrolling the fabric (FIGS. 5A and 5B).

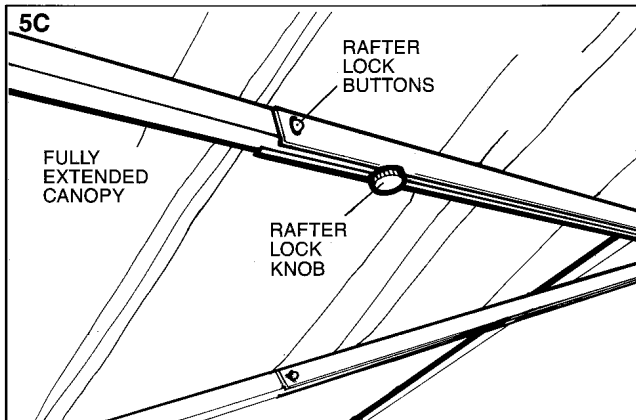

FULL EXTENSION

During operation for fully extended awning, fabric can be rolled out and rafter lock buttons will automatically snap into place to lock awning in full extension. Listen for "Click" of rafter lock buttons and continue to pull on pull-strap to make sure that rafter locks are fully set before releasing pull-strap. Tighten lock knobs (FIG. 5C).

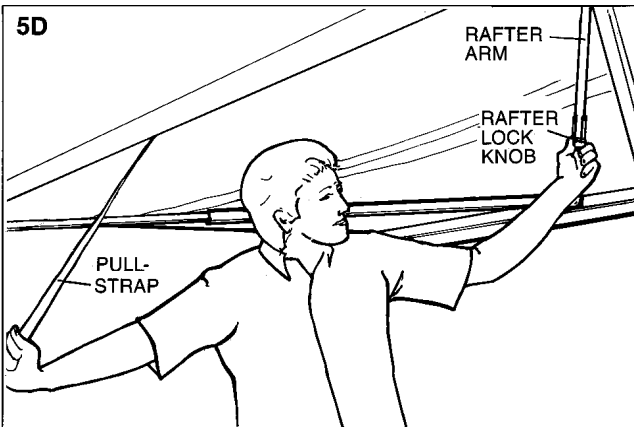

PARTIAL EXTENSION

For partially extended awning operation, roll fabric out to desired extension and while firmly grasping pull-strap tighten rafter lock knobs (FIG. 5D).

**Note:** Make sure that rafter lock knobs are tightened before releasing pull-strap.

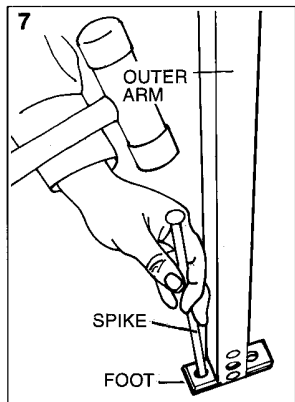
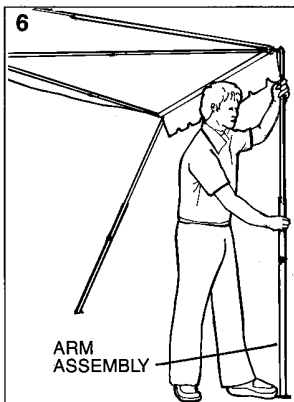

FOR PATIO POSITION

- Place arm assembly in a vertical position and adjust height (FIG. 6).
- Drive in the supplied spikes through awning foot to secure arm to ground (FIG. 7). Repeat for other side.

The Catalina 2500 Awning is now ready for you to enjoy.

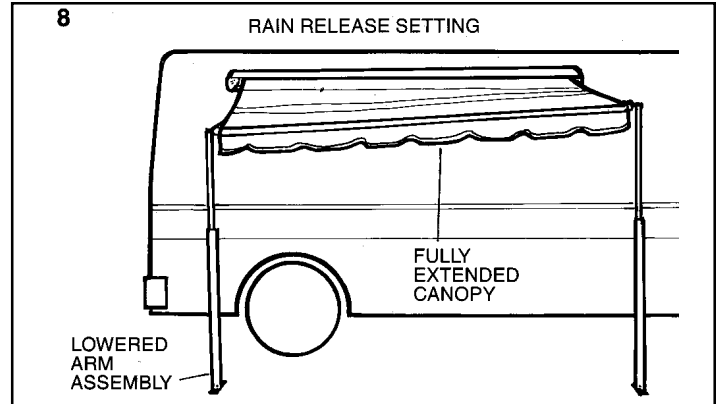

- Rain Release Setting: To avoid damage to the awning due to rain water collecting on the canopy, simply lower one of the arms enough to let the water drain from that side (FIG. 8).

# TO CLOSE

**Note:** To close on curved sided vehicles skip to Step 6.

TO CLOSE ON STRAIGHT SIDED VEHICLE

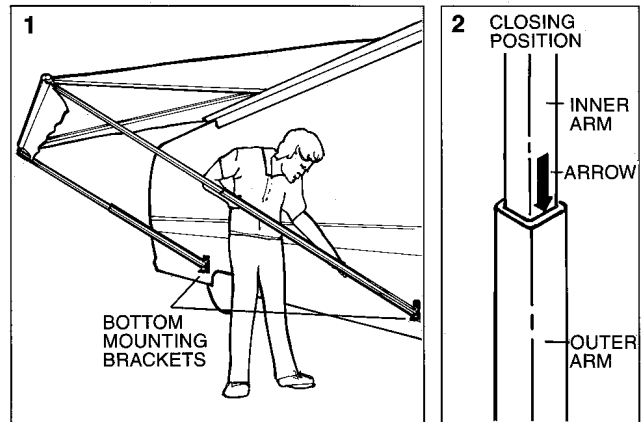

- IF AWNING IS SET IN PATIO POSITION:
  - Remove spikes from awning foot.
  - Attach foot to bottom mounting bracket on side of vehicle to set awning into pivot position (FIG. 1).
- IF AWNING IS SET IN PIVOT POSITION:
  - Lower each arm assembly to closing position indicated by arrow on inner arm and tighten lock knob (FIG. 2).

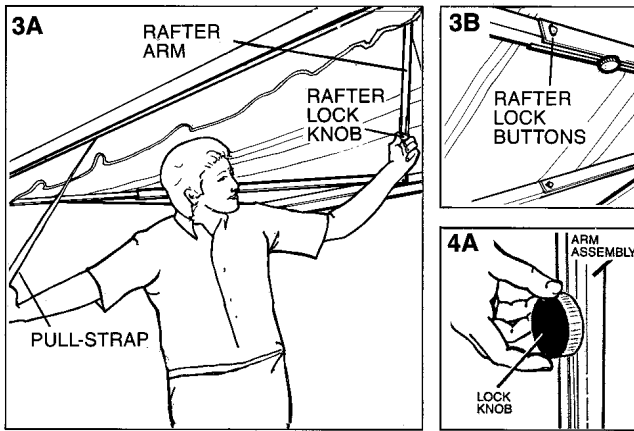

3. Firmly grasp pull-strap and loosen lock knobs (FIG. 3A). While tightly holding pull-strap, pull on strap to relieve pressure from rafter lock buttons and push rafter lock buttons in to unlock rafters and allow awning to roll up (FIG. 3B). Make sure pull-strap is centered in awning case.
4. Loosen lock knob on each arm assembly (FIG. 4A). Remove awning feet from bottom mounting brackets (FIGS. 4B and 4C).

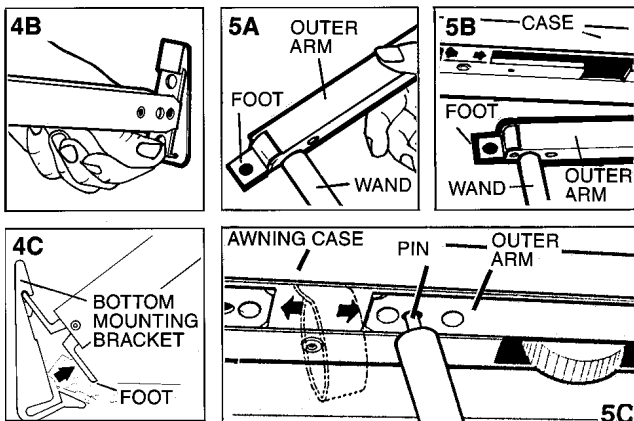

5. Insert pin at end of wand through hole in outer arm so it aligns foot for easy storage (FIG. 5A). Swing arm up to case (FIG. 5B). Slide arm and foot away from center of case so foot can be inserted into center section of awning case (FIG. 5C). Repeat for other side.

**Note:** To properly close and lock awning, lock in top of awning arm assembly must engage case lip fully (FIG. 16A and 16B).

**TO CLOSE ON CURVED SIDED VEHICLE**

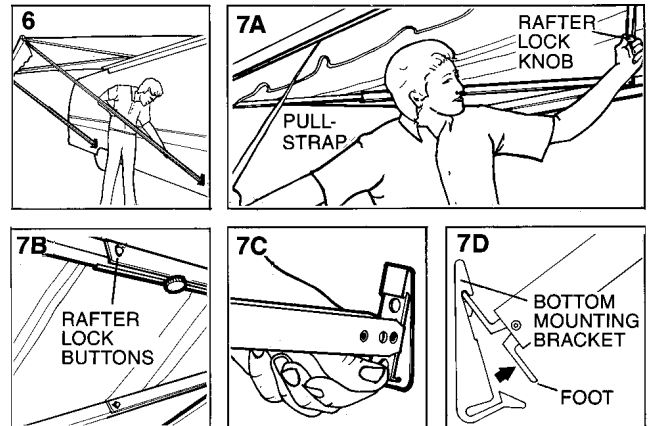

6. IF AWNING IS SET IN PATIO POSITION:
  - A. Remove spikes from awning foot.
  - B. Attach foot to bottom mounting bracket on side of vehicle to set awning into pivot position (FIG. 6). Repeat for other side. Then proceed to Step 7A.
7. IF AWNING IS SET IN PIVOT POSITION:
  - A. Firmly grasp pull-strap and loosen lock knobs (FIG. 7A). While tightly holding pull-strap, pull on strap to relieve pressure from rafter lock buttons and push rafter lock buttons in to unlock rafters (FIG. 7B). and allow awning to roll up until awning extend approximately two feet from awning case. Tighten lock knobs on both rafter arms.
  - B. Release foot from bottom mounting bracket (FIGS. 7C and 7D). Loosen lock knob and lower arm assembly vertically to ground (FIG. 7E). With foot still on ground raise inner arm until roller tube is slightly above awning case, then tighten lock knob. Repeat for other side.

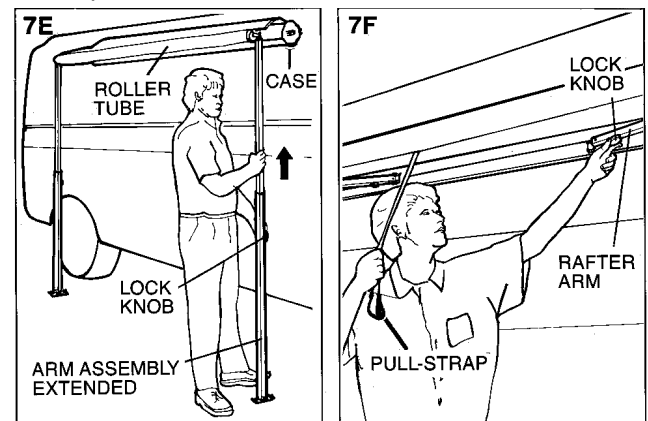

- C. Place awning feet directly below the awning case.
- D. While firmly holding the pull-strap, loosen lock knobs on rafter assembly and allow awning to close (FIG. 7F).

**Note:** Do not release pull-strap until awning has completely rolled up.

**Note:** The "D" ring on the pull-strap must remain outside

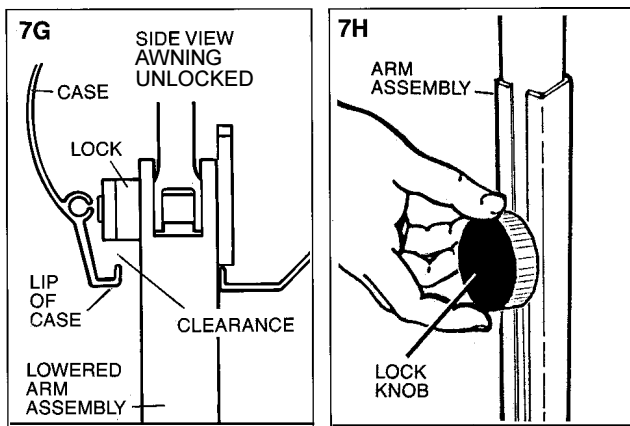

the awning case.

**Note:** Make sure lock in top of awning arm assembly engages case lip (FIG. 7G). If lock does not engage case lip, raise arm height until lock clears lip and then engages. This is necessary for proper operation of awning case locks.

E. Loosen lock knob on arm assembly (FIG. 7H).

Repeat for other side.

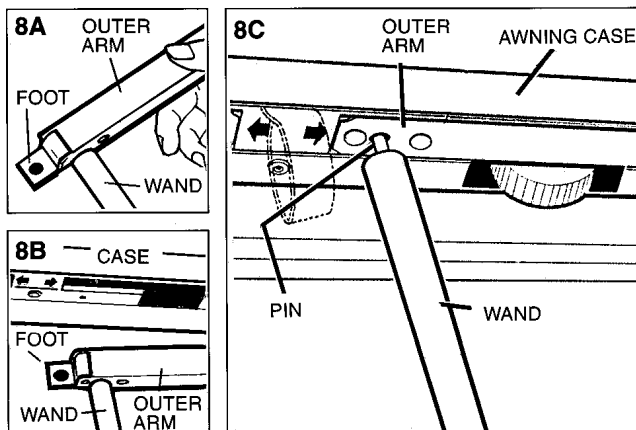

8. Insert pin at end of wand, through hole in outer arm so it aligns foot for easy storage (FIG. 8A). Swing arm up to case (FIG. 8B). Slide arm and foot away from center of case so foot can be inserted into center section of awning case (FIG. 8C). Repeat for other side.