

OPTIMUS®

Service Manual

31-3042/31-3043

MODEL STAV-3770/HTS-102(STAV-3770)

AUDIO/VIDEO RECEIVER

Catalog Number: 31-3042

31-3043

- The service manual for this product includes Pioneer's RRV1925 VSX-D307/KUXJI service manual. The pages preceding that manual list additional specifications, all service changes between Pioneer's RRV1925 VSX-D307/KUXJI and the 31-3042 STAV-3770/31-3043 HTS-102 (STAV-3770), and any RadioShack part numbers that are different from the Pioneer part numbers.
- The specifications on Page 49 of the RRV1925 service manual for Pioneer's model VSX-D307/KUXJI are like the specifications listed in the owner's manual for the 31-3042 STAV-3770/31-3043 HTS-102 (STAV-3770). Additional specs are given on the page inside the back cover.
- HOME THEATER SYSTEM Model HTS-102 contains AUDIO/VIDEO RECEIVER HTS-102 (STAV-3770) and 6 speakers (2 front speakers, 1 center speaker, 2 rear speakers and 1 passive subwoofer). The parts for the speakers are listed on page 3.

PART NUMBER DIFFERENCES BETWEEN 31-3042 STAV-3770/ 31-3043 HTS-102(STAV-3770) AND VSX-D307/KUXJI

- NOTES :
- Parts marked by “NSP” are generally unavailable .
 - \triangle indicates safety critical components. Be sure to replace only with specified parts.
 - Ref. No. : Numbers following P and hyphen(-) indicate the page(s) and location number(s) in the RRV1925 service manual, respectively.

31-3042 STAV-3770/31-3043 HTS-102(STAV-3770) and VSX-D307/KUXJI are constructed the same except for the following:

Ref. No.	Mark	Symbol and Description	Part No.			Remarks
			VSX-D307 /KUXJI	31-3042 STAV-3770	31-3043 HTS-102	
		PACKING				
P3 - 3		Operating Instructions (English)	ARB7136	ARB7149	ARB7149	
P3 - 4	NSP	Warranty Card	ARY1051	Not used	Not used	
P3 - 5		Remote Control Unit (CU-VSX124)	AXD7161	Not used	Not used	
P3 - 5		Remote Control Unit	Not used	AXD7176	AXD7176	
P3 - 7	NSP	Dry Cell Battery (R6P, AA)	VEM-013	Not used	Not used	
P3 - 11		Packing Case	AHD7557	AHD7592	AHD7634	
		EXTERIOR SECTION				
P5 - 17		Rear Panel	ANC7627	ANC7662	ANC7702	
		FRONT PANEL SECTION				
P6 - 5		Power Button	AAD7440	AAD7472	AAD7472	
P6 - 7		PIONEER Badge	PAM1755	Not used	Not used	
P6 - 7		OPTIMUS Badge	Not used	AAM7001	AAM7001	
P6 - 9		Sheet	AAK7539	Not used	Not used	
P6 - 9		FL Panel	Not used	AAK7560	AAK7560	
		Front Panel Assy	Not used	AMB7511	AMB7511	
P6 - 6		└ Function Button (1/2)	AAD7441	AAD7458	AAD7458	
P6 - 6		└ Function Button (2/2)	AAD7441	AAD7441	AAD7441	
P6 - 10		└ Sub Panel	AAP7040	AAP7045	AAP7045	
P6 - 11		└ Front Panel	AMB7494	Not used	Not used	
P6 - 11	NSP	└ Front Panel	Not used	AMB7505	AMB7505	
		SPEAKER				
		Front Speaker	Not used	Not used	*1	
		Center and Rear Speaker	Not used	Not used	*1	
		Passive Subwoofer	Not used	Not used	*1	
		ACCESSORY				
		RCA Cable Accesory Assy	Not used	Not used	259029	

Note *1: Refer to "31-3043 HTS-102 SPEAKERS".

31-3043 HTS-102 SPEAKERS

■ FRONT SPEAKER PARTS LIST

Mark	No.	Description	Part No.
	1	Speaker Wire Set (16' 18ga) for Front Speaker	258224
	2	Cabinet W/Speaker (Front Speaker)	258997

■ CENTER AND REAR SPEAKER PARTS LIST

Mark	No.	Description	Part No.
	1	Speaker Wire Set (8' 18ga) for Center and Rear Speaker	258284
	2	Cabinet W/Speaker (Center Speaker)	259009
	3	Cabinet W/Speaker (Rear Speaker)	259014

■ PASSIVE SUBWOOFER PARTS LIST

Mark	No.	Description	Part No.
	1	Speaker Wire Set (10' 18ga) for Subwoofer	242393
	2	Low Freq. Transducer (8-inch cone woofer unit)	20-207A/XL
	3	SCR PPD0008PO4/4FBO (Woofer)	2221904
	4	Logo Badge	258922
	5	Front Port Ring	258635
	6	Rear Port Ring	258640
	7	Paper Port Tube	255136
	8	Foot W/Non Skid Pad	250111
	9	SCR PPD0008PO5/4FBO (Foot)	222539
	10	Terminal with Network	255121
	11	SCR PPD000605/8FBO (Terminal)	222539

Service Manual

PIONEER
The Art of Entertainment

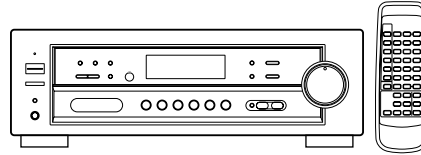

ORDER NO.
RRV1925

AUDIO/VIDEO MULTI-CHANNEL RECEIVER

VSX-D307

THIS MANUAL IS APPLICABLE TO THE FOLLOWING MODEL(S) AND TYPE(S).

Type	Model	Power Requirement	Remarks
	VSX-D307		
KUXJ	○	AC120V	
KUXJI	○	AC120V	
KCXJI	○	AC120V	

CONTENTS

1. SAFETY INFORMATION	2	7. GENERAL INFORMATION	36
2. EXPLODED VIEWS AND PARTS LIST	3	7.1 PARTS	36
3. SCHEMATIC DIAGRAM	8	7.1.1 IC	36
4. PCB CONNECTION DIAGRAM	24	7.1.2 DISPLAY	38
5. PCB PARTS LIST	30	7.2 DISASSEMBLY	39
6. ADJUSTMENT	35	7.3 DIAGNOSIS	41
		7.4 BLOCK DIAGRAM	42
		8. PANEL FACILITIES AND SPECIFICATIONS ..	44

1. SAFETY INFORMATION

This service manual is intended for qualified service technicians ; it is not meant for the casual do-it-yourselfer. Qualified technicians have the necessary test equipment and tools, and have been trained to properly and safely repair complex products such as those covered by this manual.

Improperly performed repairs can adversely affect the safety and reliability of the product and may void the warranty. If you are not qualified to perform the repair of this product properly and safely, you should not risk trying to do so and refer the repair to a qualified service technician.



WARNING

Lead in solder used in this product is listed by the California Health and Welfare agency as a known reproductive toxicant which may cause birth defects or other reproductive harm (California Health & Safety Code, Section 25249.5).

When servicing or handling circuit boards and other components which contain lead in solder, avoid unprotected skin contact with the solder. Also, when soldering do not inhale any smoke or fumes produced.



NOTICE

(FOR CANADIAN MODEL ONLY)

Fuse symbols  (fast operating fuse) and/or  (slow operating fuse) on PCB indicate that replacement parts must be of identical designation.

REMARQUE

(POUR MODÈLE CANADIEN SEULEMENT)

Les symboles de fusible  (fusible de type rapide) et/ou  (fusible de type lent) sur CCI indiquent que les pièces de remplacement doivent avoir la même désignation.

(FOR USA MODEL ONLY)

1. SAFETY PRECAUTIONS

The following check should be performed for the continued protection of the customer and service technician.

LEAKAGE CURRENT CHECK

Measure leakage current to a known earth ground (water pipe, conduit, etc.) by connecting a leakage current tester such as Simpson Model 229-2 or equivalent between the earth ground and all exposed metal parts of the appliance (input/output terminals, screwheads, metal overlays, control shaft, etc.). Plug the AC line cord of the appliance directly into a 120V AC 60Hz outlet and turn the AC power switch on. Any current measured must not exceed 0.5mA.

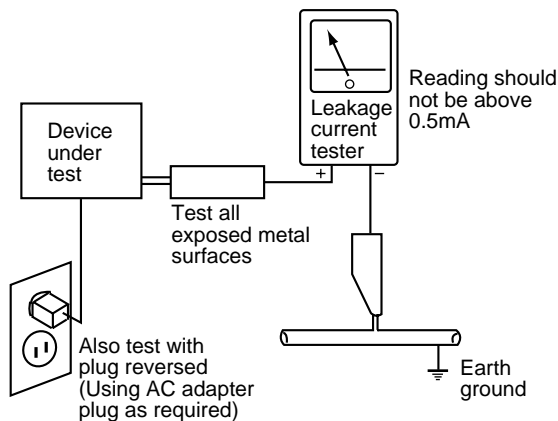

AC Leakage Test

ANY MEASUREMENTS NOT WITHIN THE LIMITS OUTLINED ABOVE ARE INDICATIVE OF A POTENTIAL SHOCK HAZARD AND MUST BE CORRECTED BEFORE RETURNING THE APPLIANCE TO THE CUSTOMER.

2. PRODUCT SAFETY NOTICE

Many electrical and mechanical parts in the appliance have special safety related characteristics. These are often not evident from visual inspection nor the protection afforded by them necessarily can be obtained by using replacement components rated for voltage, wattage, etc. Replacement parts which have these special safety characteristics are identified in this Service Manual.

Electrical components having such features are identified by marking with a Δ on the schematics and on the parts list in this Service Manual.

The use of a substitute replacement component which does not have the same safety characteristics as the PIONEER recommended replacement one, shown in the parts list in this Service Manual, may create shock, fire, or other hazards.

Product Safety is continuously under review and new instructions are issued from time to time. For the latest information, always consult the current PIONEER Service Manual. A subscription to, or additional copies of, PIONEER Service Manual may be obtained at a nominal charge from PIONEER.

2. EXPLODED VIEWS AND PARTS LIST

- NOTES:
- Parts marked by "NSP" are generally unavailable because they are not in our Master Spare Parts List.
 - The Δ mark found on some component parts indicates the importance of the safety factor of the part. Therefore, when replacing, be sure to use parts of identical designation.
 - Screws adjacent to \blacktriangledown mark on the product are used for disassembly.

2.1 PACKING

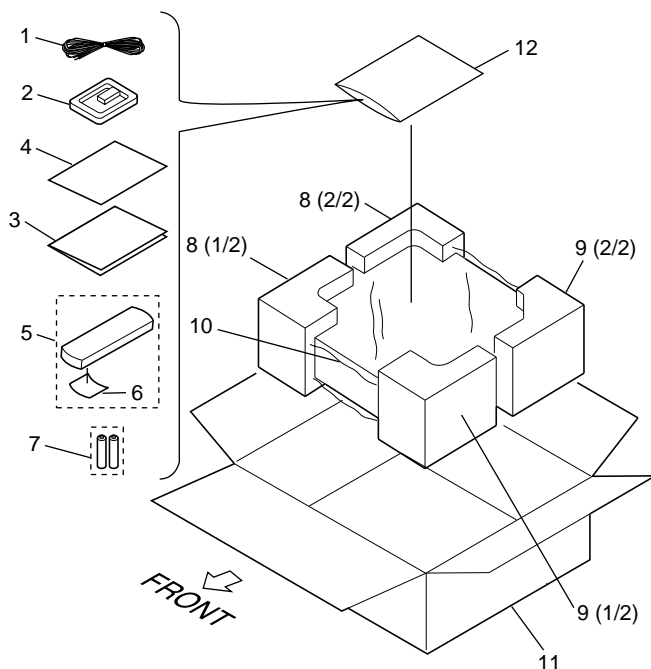

(1) PACKING PARTS LIST

Mark	No.	Description	Part No.
	1	FM Antenna	ADH7004
	2	AM Loop Antenna	ATB7009
NSP	3	Operating Instructions	See Contrast table (2)
	4	Warranty Card	See Contrast table (2)
	5	Remote Control Unit (CU-VSX124)	AXD7161
NSP	6	Battery Cover	RZN1156
	7	Dry Cell Battery (R6P, AA)	VEM-013
	8	Left Pad	AHA7203
	9	Right Pad	AHA7204
	10	Packing Sheet	AHG1218
	11	Packing Case	See Contrast table (2)
	12	Polyethylene Bag (0.03×230×340)	Z21-038

(2) CONTRAST TABLE

VSX-D307/KUXJ, KUXJI and KCXJI are constructed the same except for the following :

Mark	No.	Symbol and Description	Part No.			Remarks
			VSX-D307/KUXJ	VSX-D307/KUXJI	VSX-D307/KCXJI	
NSP	3	Operating Instructions (English)	ARB7136	ARB7136	Not used	
	3	Operating Instructions (English/French)	Not used	Not used	ARE7159	
	4	Warranty Card	ARY1051	ARY1051	ARY1075	
	11	Packing Case	AHD7595	AHD7557	AHD7582	

■ Accessories

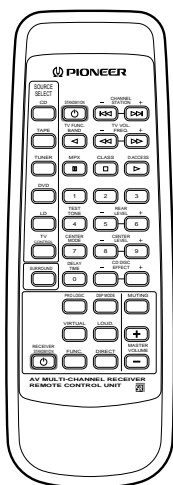

Remote Control Unit
(CU-VSX124 : AXD7161)

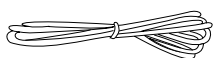

FM Antenna : ADH7004

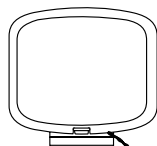

AM Loop Antenna : ATB7009

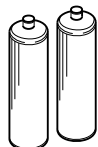

Dry Cell Battery : VEM-013
(size "AA" IEC R6P) × 2

2.2 EXTERIOR SECTION

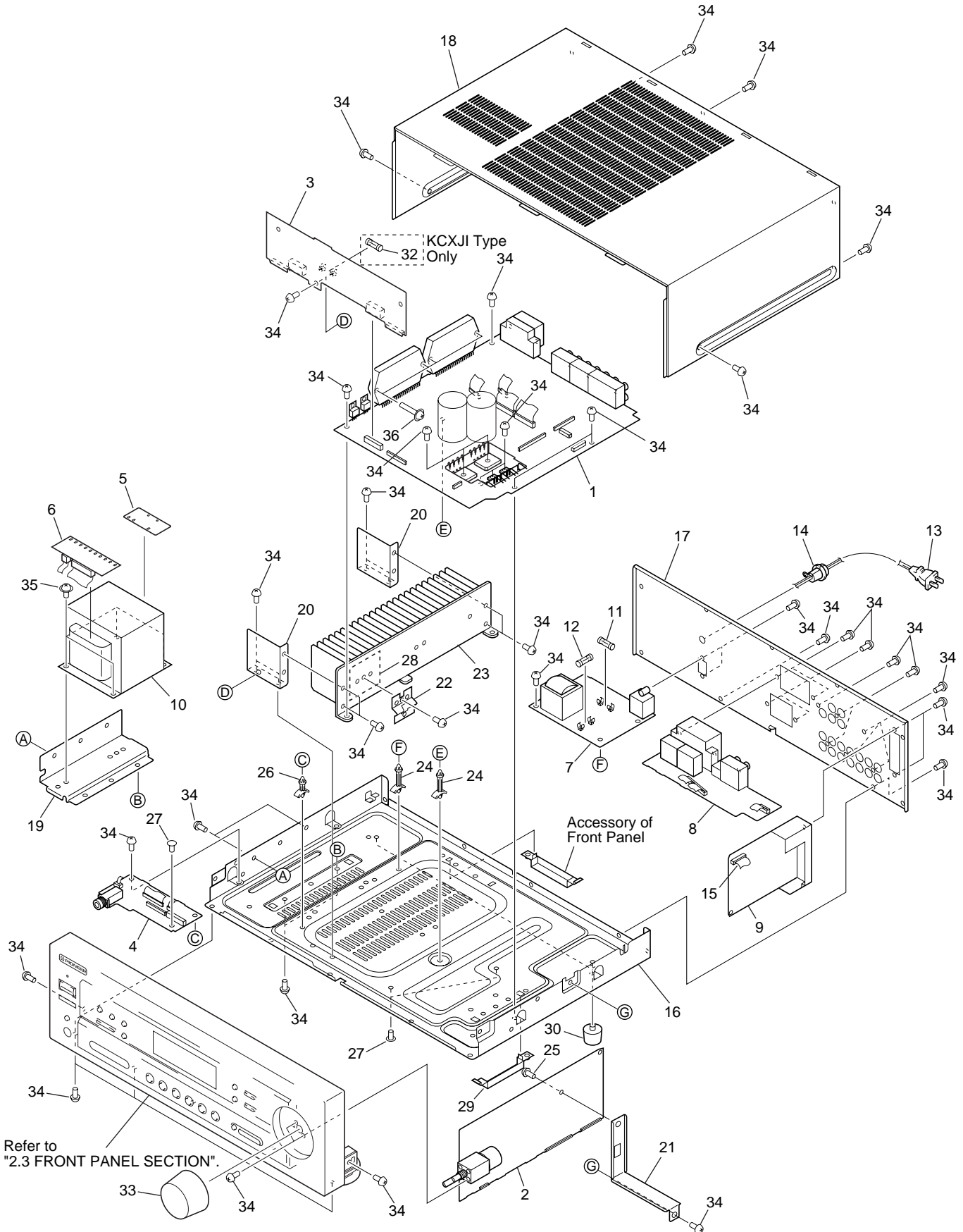

(1) EXTERIOR SECTION PARTS LIST

Mark	No.	Description	Part No.	Mark	No.	Description	Part No.
	1	MOTHER Assy	See Contrast table (2)		21	PCB Angle	ANG7180
	2	VOLUME DSP Assy	AWX7064		22	FET Angle	ANG7186
NSP	3	CONNECTION Assy	See Contrast table (2)	NSP	23	Heat Sink	ANH7075
	4	HEADPHONE Assy	AWX7066		24	PCB Support	AEC7006
NSP	5	TRANS 1 Assy	AWX7070		25	Push Rivet	AEC7025
	6	TRANS 2 Assy	AWX7071		26	PCB Support	AEC7132
	7	PRIMARY Assy	AWX7067		27	Card Spacer	AEC7133
	8	FRONT SPEAKER Assy	AWX7068		28	Mica Sheet	AEE7026
	9	FM/AM TUNER Unit	AXX7046		29	Screw Cover	AMR7199
△	10	Power Transformer (T1 : AC120V)	ATS7205		30	Foot Assy	REC1263
	11	Fuse (FU2 : 8A)	REK1086		31	•••••	
△	12	Fuse (FU1 : 10A)	REK1087	△	32	Fuse (FU91 : 10A)	See Contrast table (2)
△	13	AC Power Cord	PDG1057		33	Round Knob	AAB7082
	14	Cord Stopper	CM-22C		34	Screw	BBZ30P080FZK
	15	Flexible Cable 13P (J32) (MOTHER CN110-FM/AM TUNER Unit)	ADD7081		35	Screw	ABA7044
	16	Under Base	ANA7067		36	Screw	ABA7043
NSP	17	Rear Panel	See Contrast table (2)				
	18	Bonnet Case	AZN7710				
	19	T Angle	ANG7178				
	20	H Angle	ANG7179				

(2) CONTRAST TABLE

VSX-D307/KUXJ, KUXJI and KCXJI are constructed the same except for the following :

Mark	No.	Symbol and Description	Part No.			Remarks
			VSX-D307/KUXJ	VSX-D307/KUXJI	VSX-D307/KCXJI	
	1	MOTHER Assy	AWX7058	AWX7058	AWX7177	
NSP	3	CONNECTION Assy	AWX7060	AWX7060	AWX7176	
	17	Rear Panel	ANC7663	ANC7627	ANC7691	
△	32	Fuse (FU91 : 10A)	Not used	Not used	REK1087	

2.3 FRONT PANEL SECTION

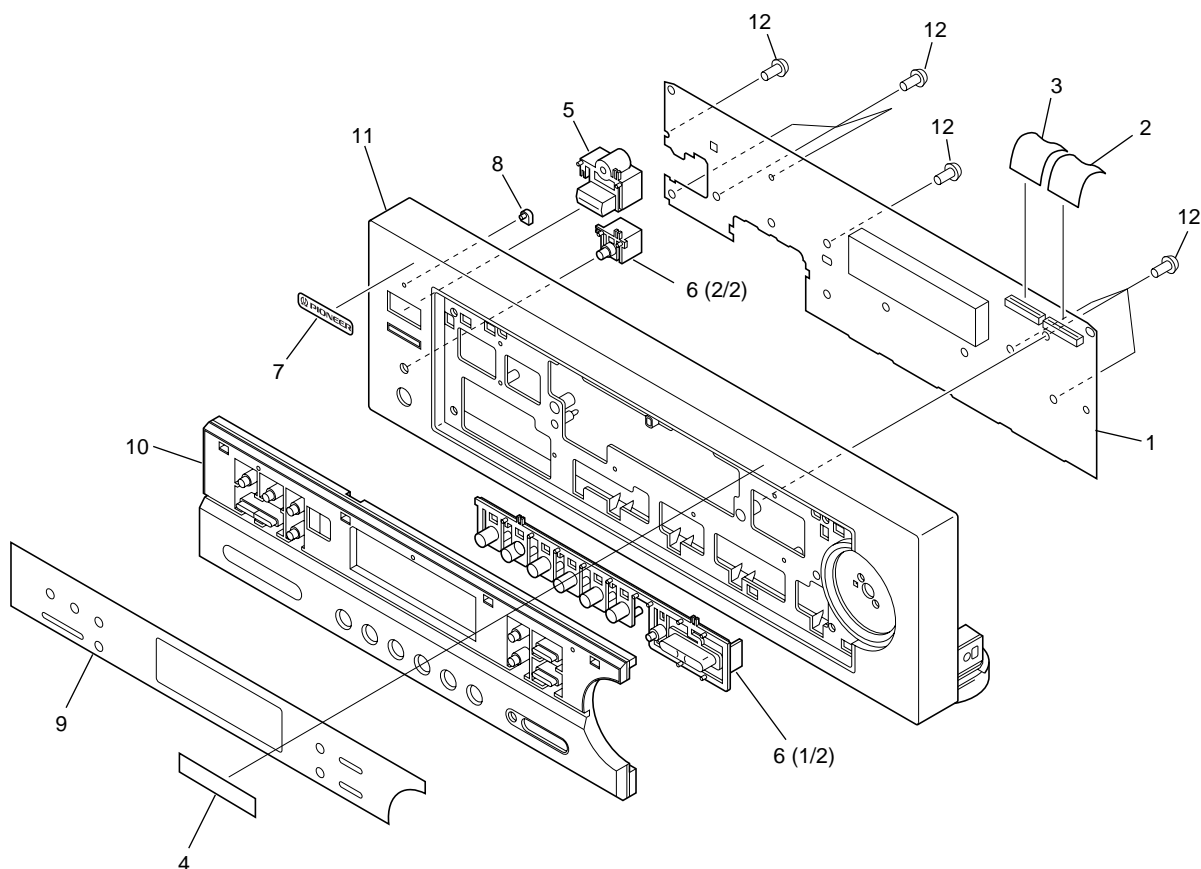

(1) FRONT PANEL SECTION PARTS LIST

Mark	No.	Description	Part No.
	1	FRONT Assy	AWX7062
	2	Flexible Cable 20P (J31) (MOTHER CN109-FRONT CN501)	ADD7083
	3	Flexible Cable 20P (J35) (MOTHER CN111-FRONT CN502)	ADD7083
NSP	4	Getter	AAX7631
	5	Power Button	AAD7440
	6	Function Button	AAD7441
	7	PIONNER Badge	PAM1755
	8	LED Lens	PNW2019
	9	Sheet	AAK7539
	10	Sub Panel	AAP7040
	11	Front Panel	AMB7494
	12	Screw	BPZ30P080FMC

3. SCHEMATIC DIAGRAM

3.1 OVERALL CONNECTION DIAGRAM

Note : When ordering service parts, be sure to refer to "EXPLODED VIEWS and PARTS LIST" or "PCB PARTS LIST".

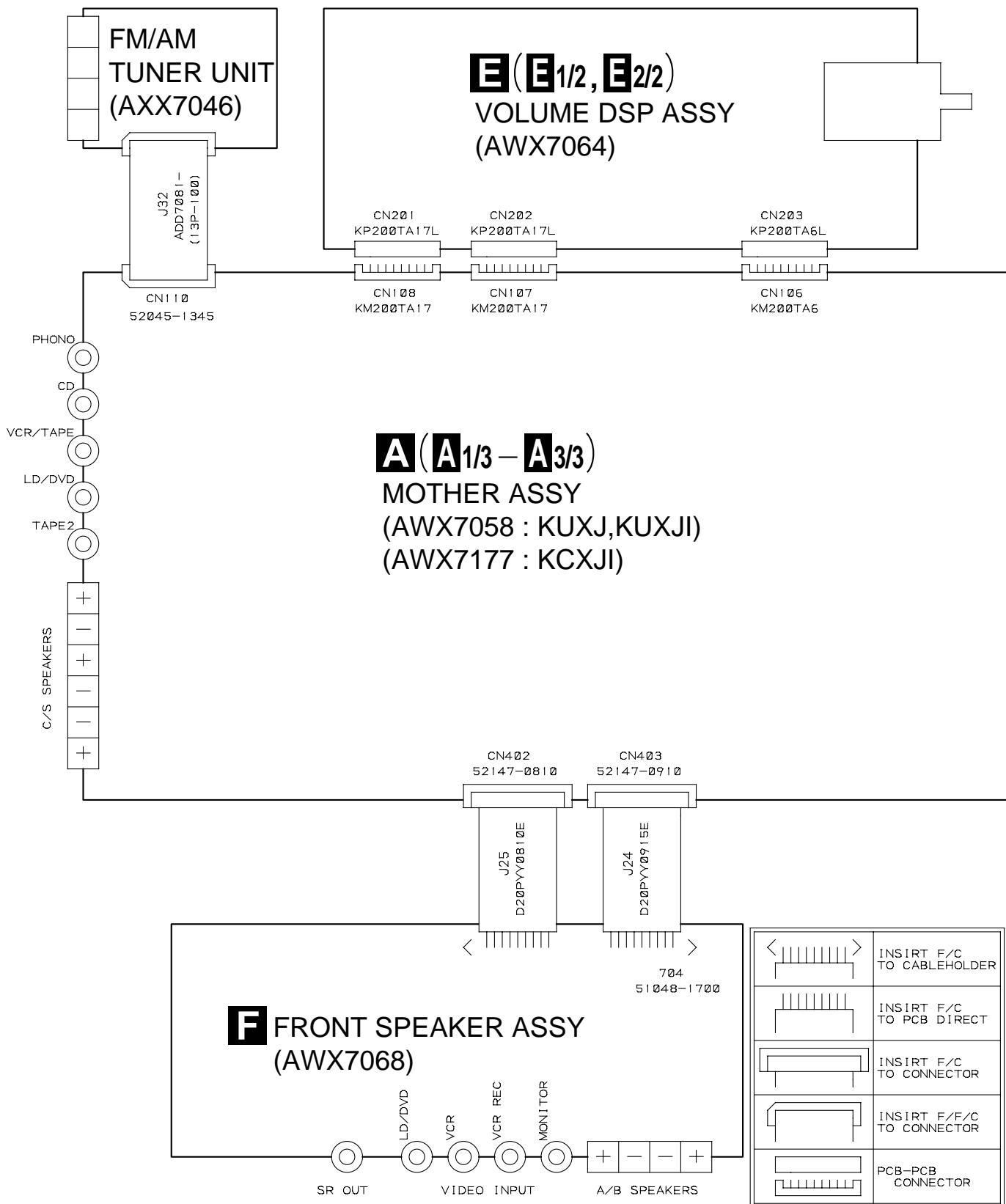

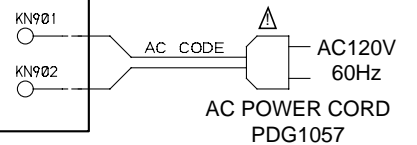
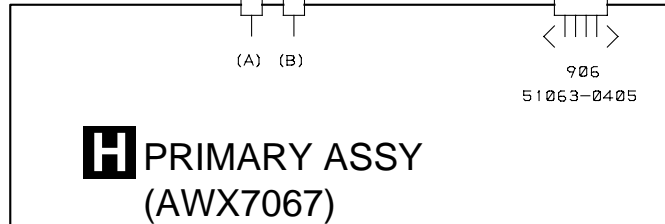
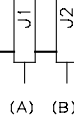
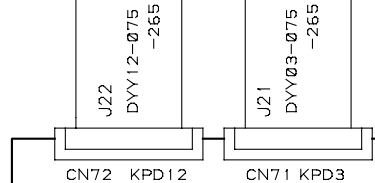
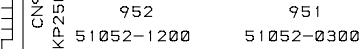
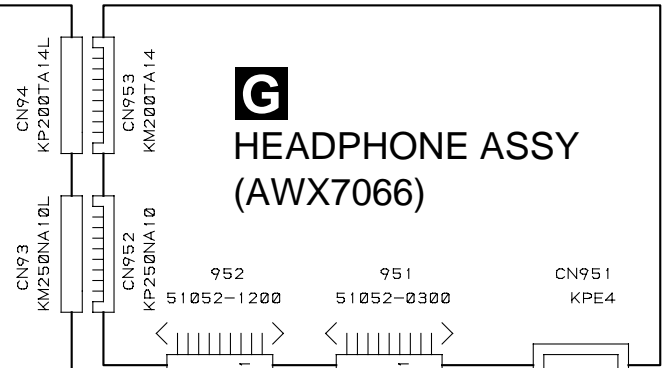
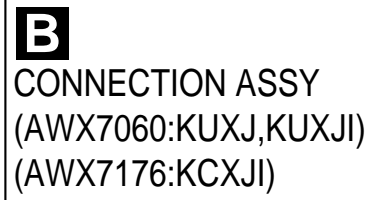
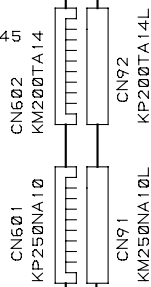
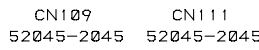
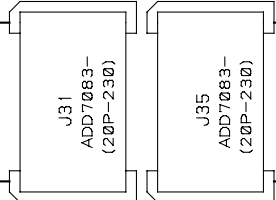
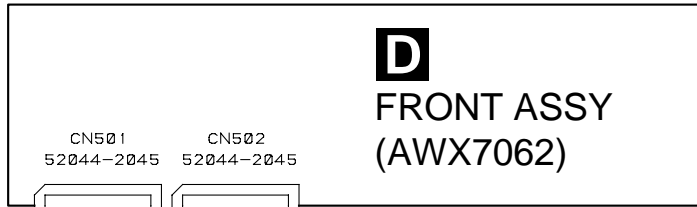

3.2 MOTHER ASSY (1/3)

A 1/3 MOTHER ASSY
(AWX7058:KUXJ,KUXJI)
(AWX7177:KCXJI)

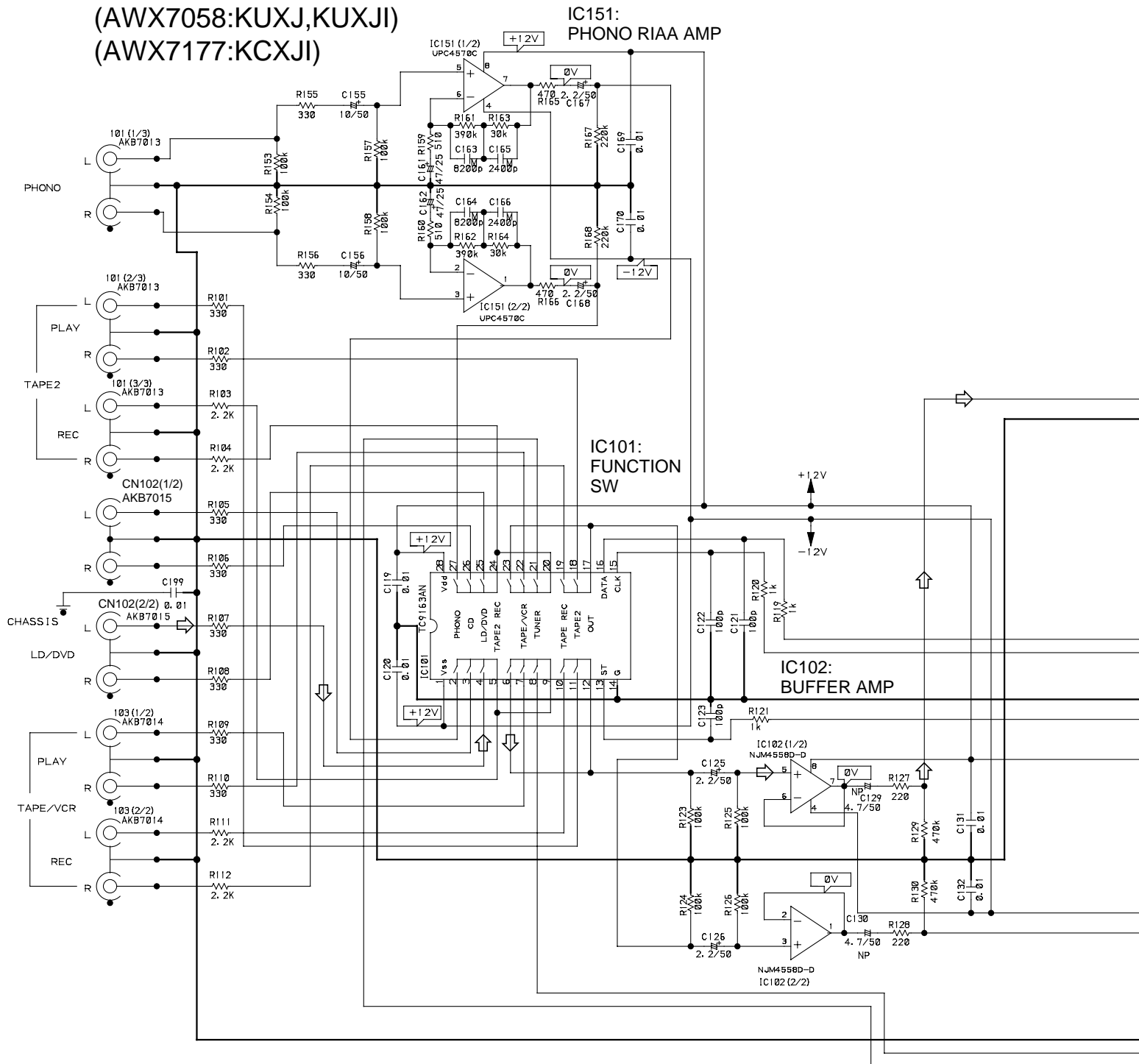

NOTES: NO INDICATED PARTS IS...

RESISTOR: PD1/4PU***J-T
 CEMICAL CAPASITOR: CEAT***M***-T
 CERAMIC CAPASITOR: CCC... or KC...
 DIODE: ISS254-T

- : AUDIO SIGNAL ROUTE
- (C) → : AUDIO SIGNAL ROUTE (CENTER)
- (S) → : AUDIO SIGNAL ROUTE (SURROUND)

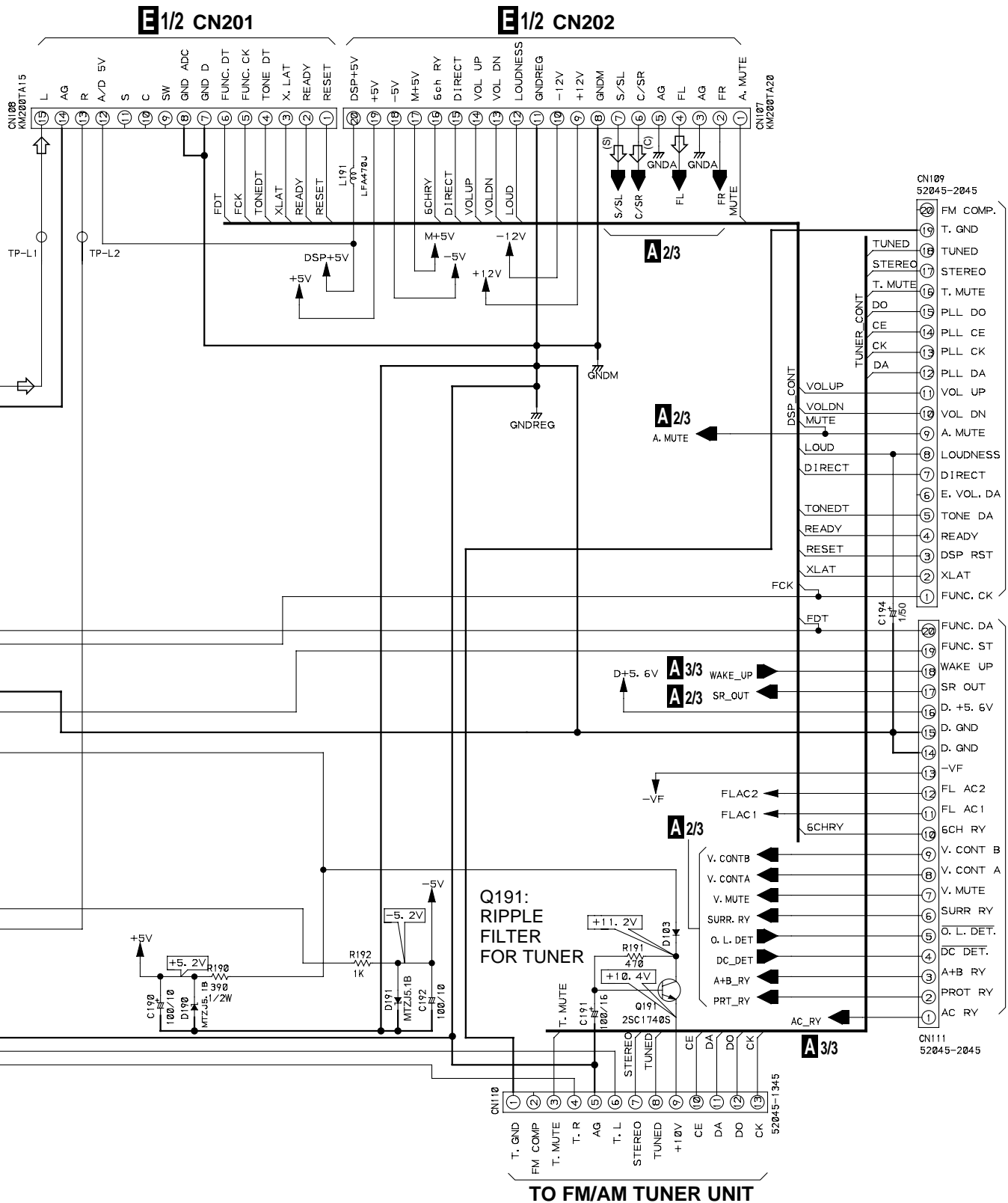

3.3 MOTHER ASSY (2/3)

A

A 2/3 MOTHER ASSY
(AWX7058:KUXJ,KUXJI)
(AWX7177:KCXJI)

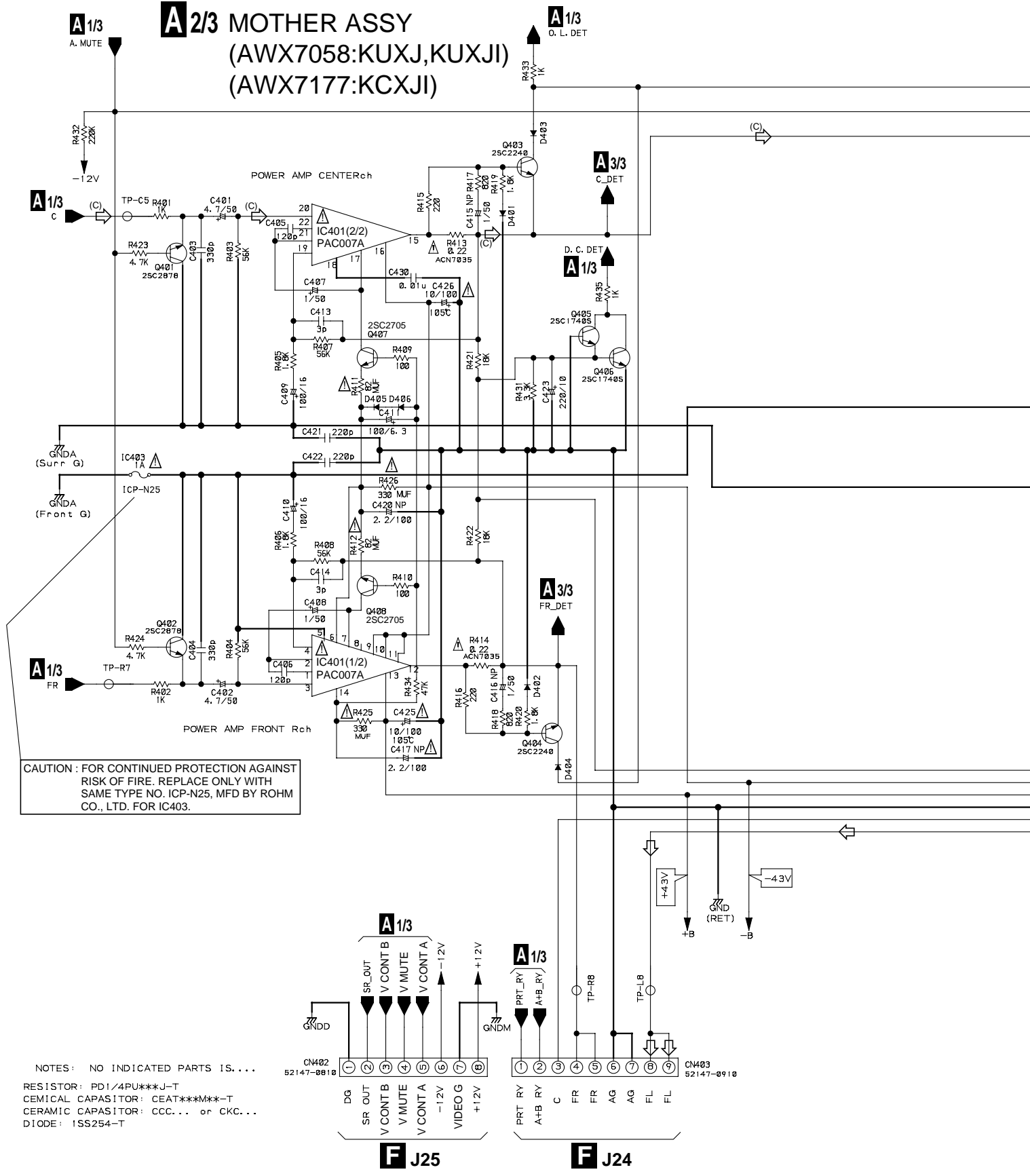

CAUTION : FOR CONTINUED PROTECTION AGAINST RISK OF FIRE. REPLACE ONLY WITH SAME TYPE NO. ICP-N25, MFD BY ROHM CO., LTD. FOR IC403.

D

NOTES: NO INDICATED PARTS IS...
RESISTOR: PD1/4PU***J-T
CEMICAL CAPASITOR: CEAT***M**T
CERAMIC CAPASITOR: CCC... or KC...
DIODE: ISS254-T

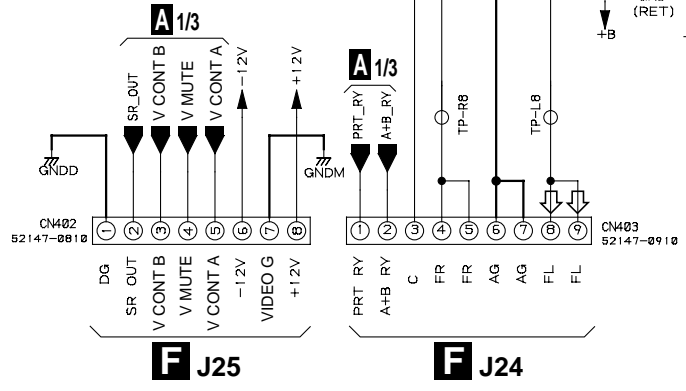

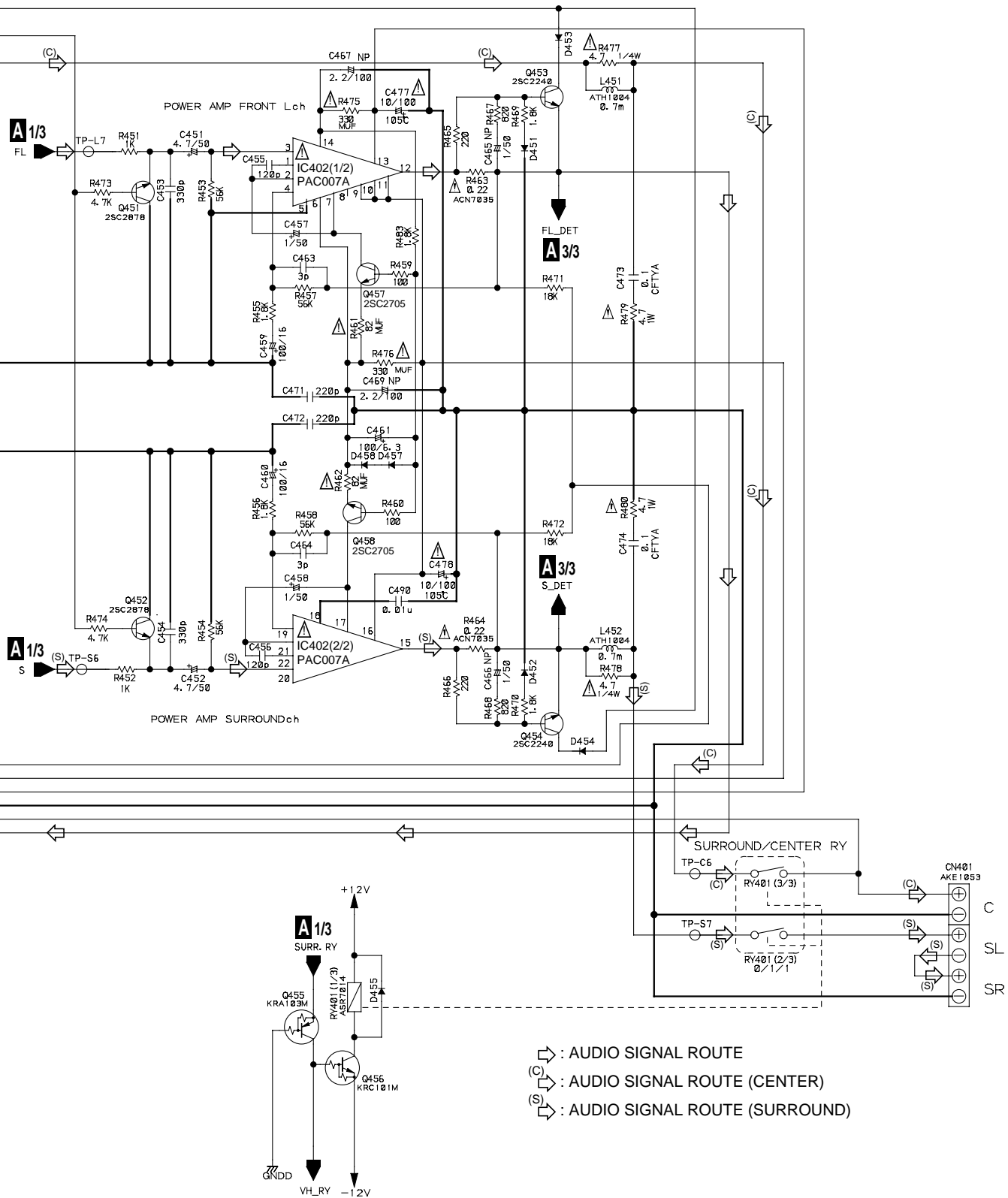

3.4 MOTHER (3/3), CONNECTION AND TRANS 2 ASSEMBLIES

A

B

C

D

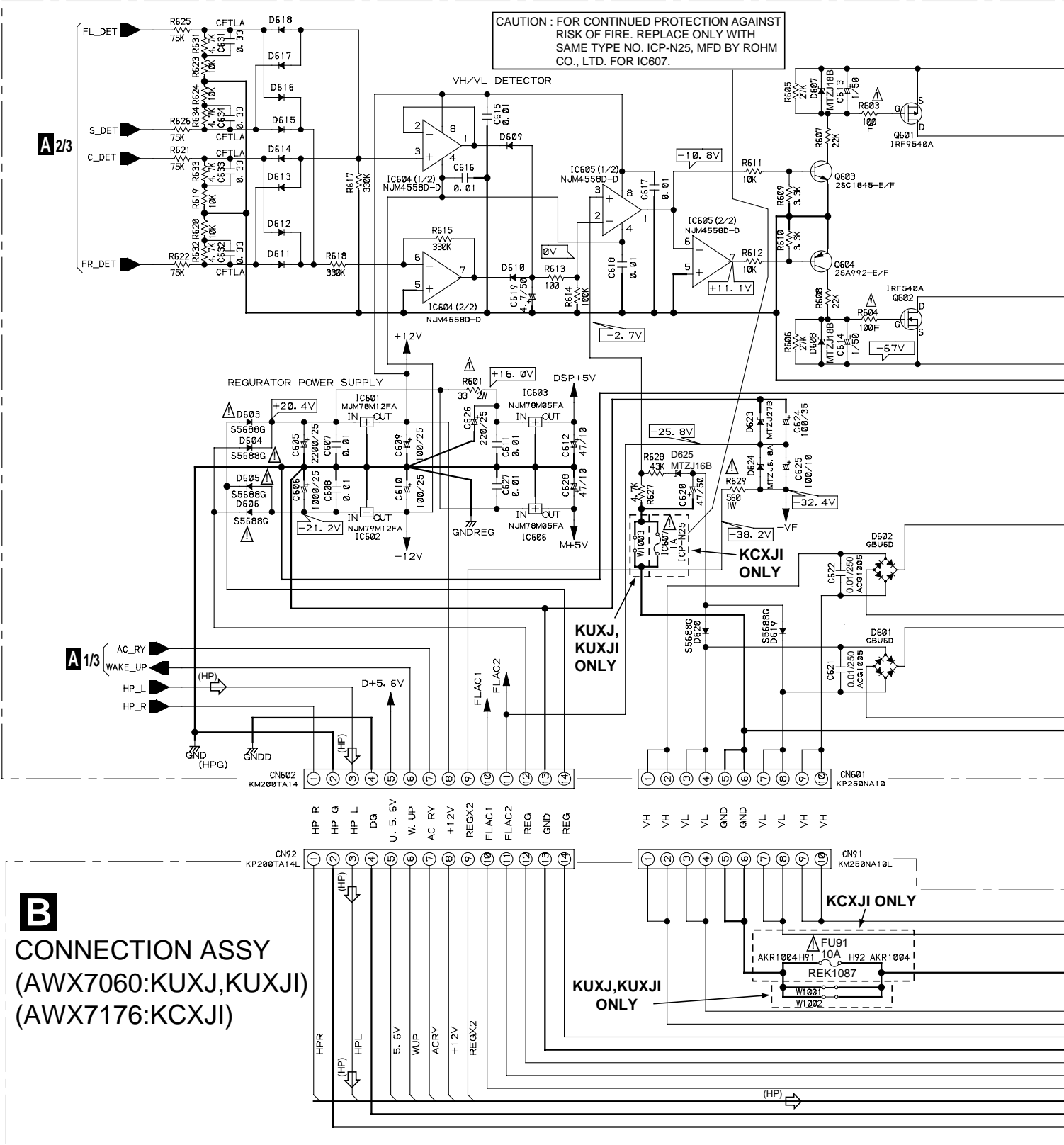

• NOTE FOR FUSE REPLACEMENT
CAUTION - FOR CONTINUED PROTECTION AGAINST RISK OF FIRE, REPLACE ONLY WITH SAME TYPE AND RATINGS ONLY.

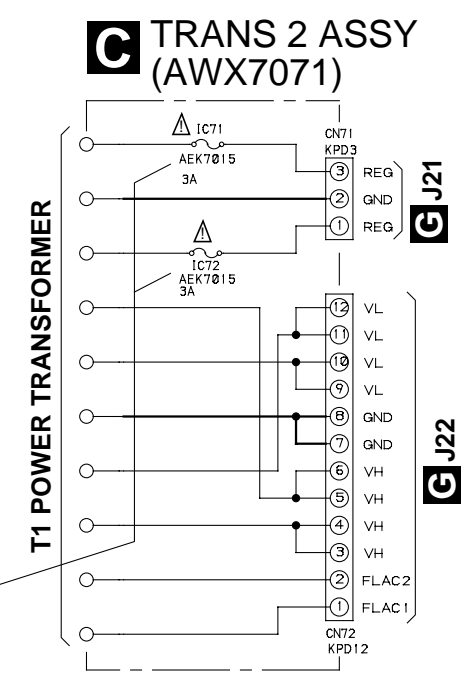
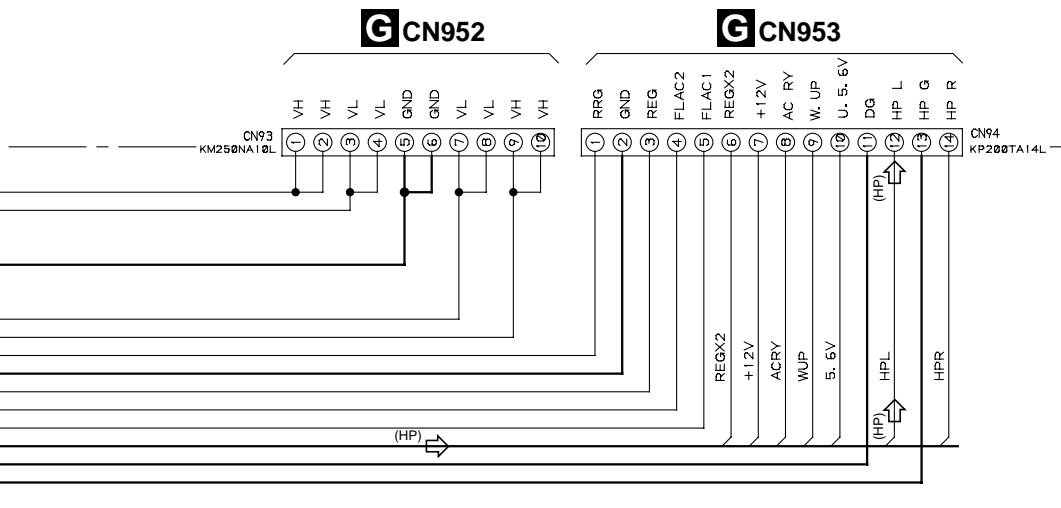
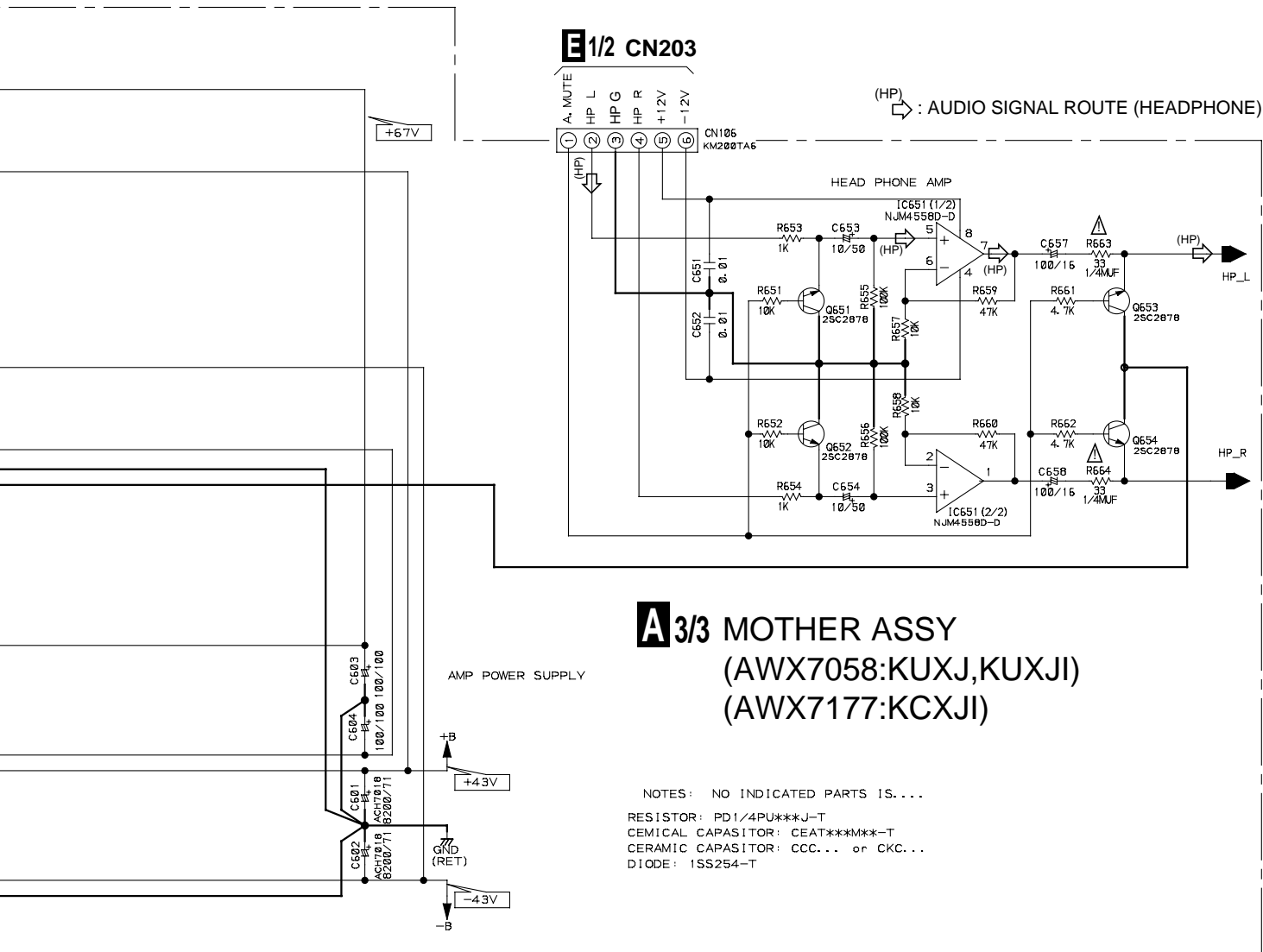

3.5 FRONT ASSY

A

A/1/3 CN109

A/1/3 CN111

D FRONT ASSY (AWX7062)

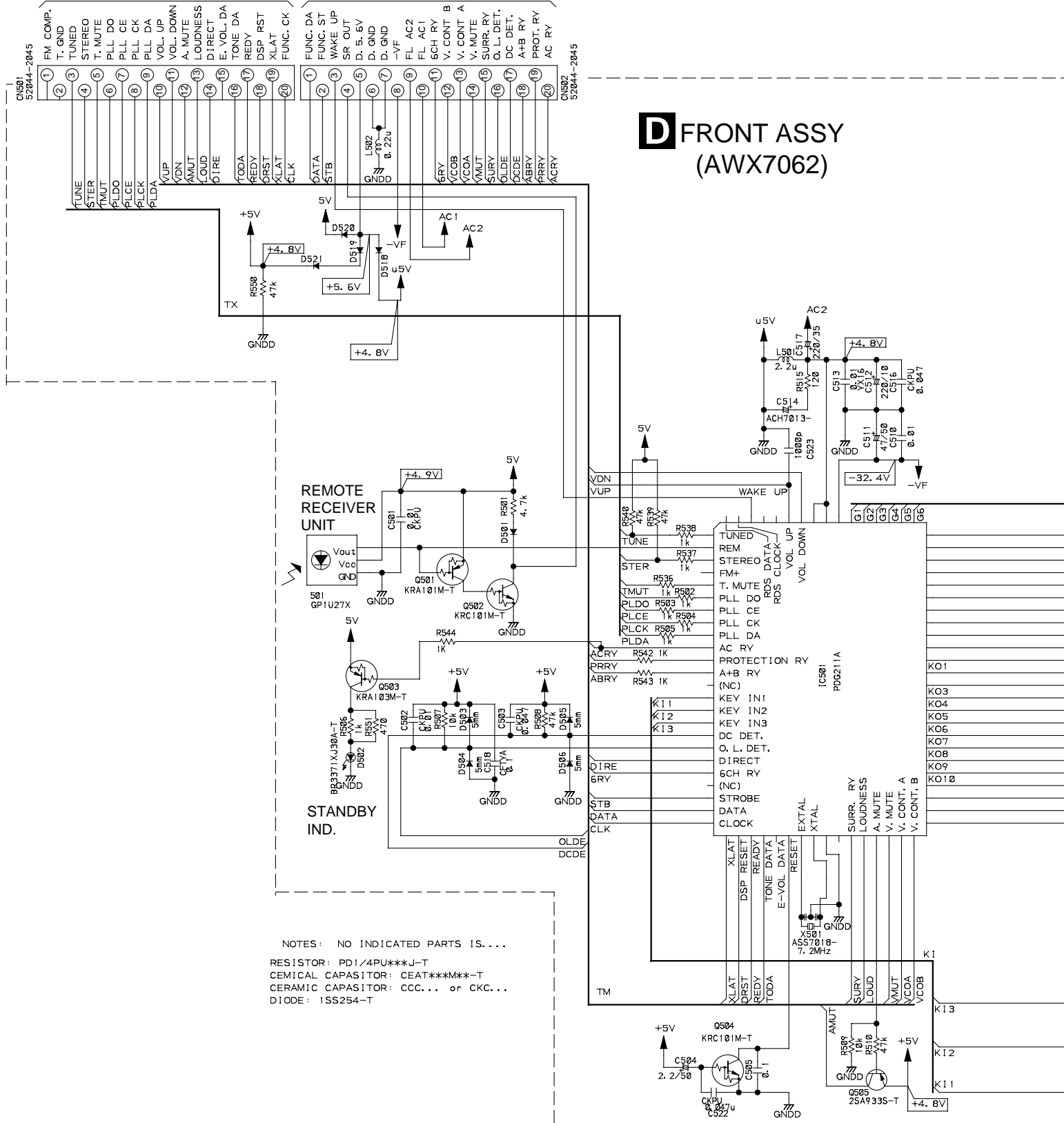

NOTES: NO INDICATED PARTS IS...
 RESISTOR: PD1/4PU***J-T
 CEMICAL CAPASITOR: CEAT***M***-T
 CERAMIC CAPASITOR: CCC... or CKC...
 DIODE: ISS254-T

D



- S501 : SPEAKER
- S502 : SELECT
- S503 : TAPE 2 MONITOR
- S505 : TONE(-) / BALANCE(L)
- S506 : PHONO
- S507 : STANDBY / ON
- S508 : TONE(+) / BALANCE(R)
- S509 : FM / AM
- S510 : STATION / FREQUENCY(-)
- S511 : DOLBY PRO LOGIC
- S512 : CD
- S513 : MEMORY
- S514 : DOLBY VIRTUAL
- S515 : DVD / LD
- S516 : STATION / FREQUENCY(+)
- S517 : LOUDNESS
- S518 : VCR / TAPE 1
- S520 : DSP MODE
- S522 : CLASS
- S523 : TUNING SELECT
- S524 : MPX MODE

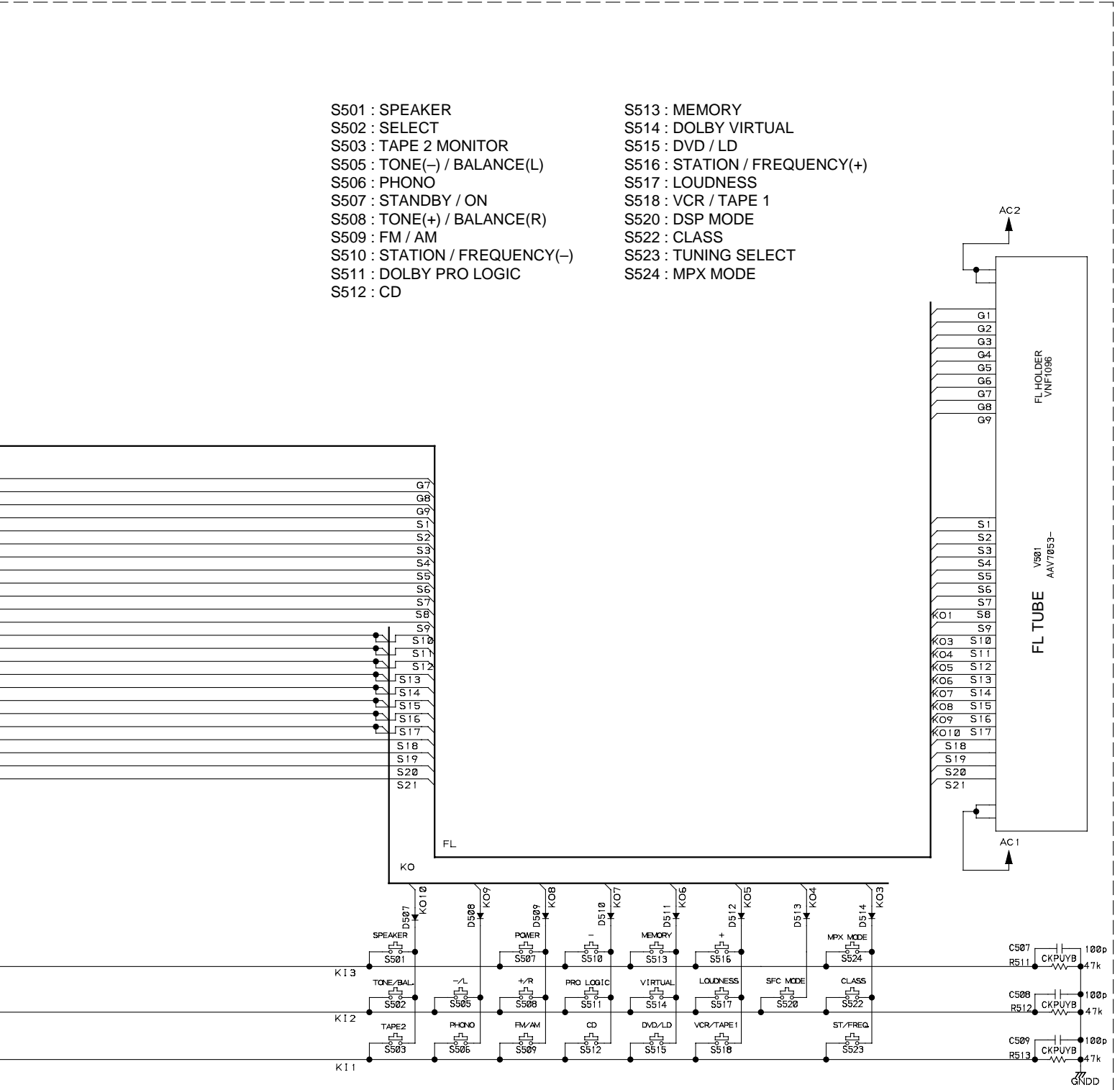

3.6 VOLUME DSP ASSY (1/2)

E 1/2 VOLUME DSP ASSY(AWX7064)

A

B

C

D

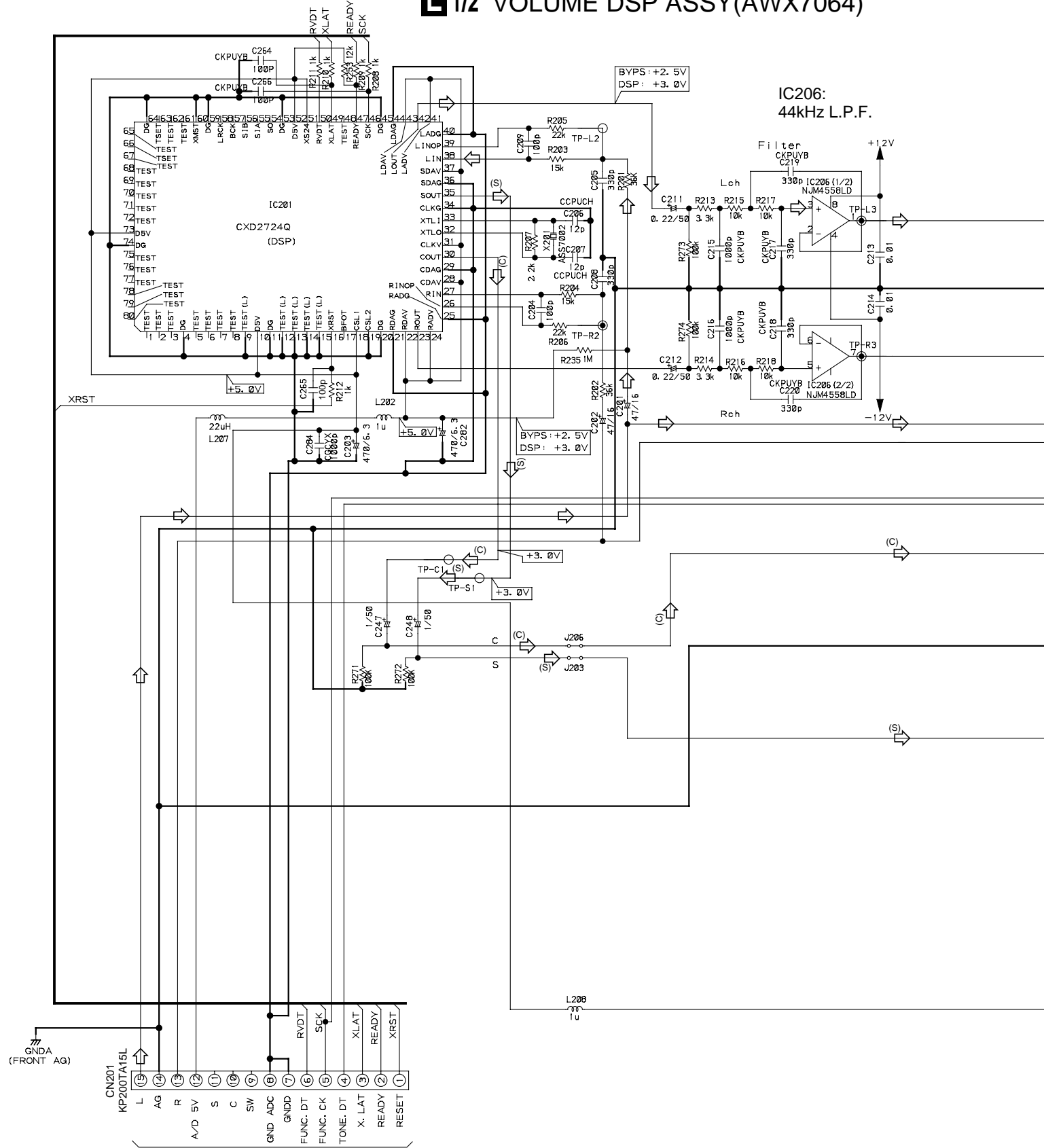

A1/3 CN108

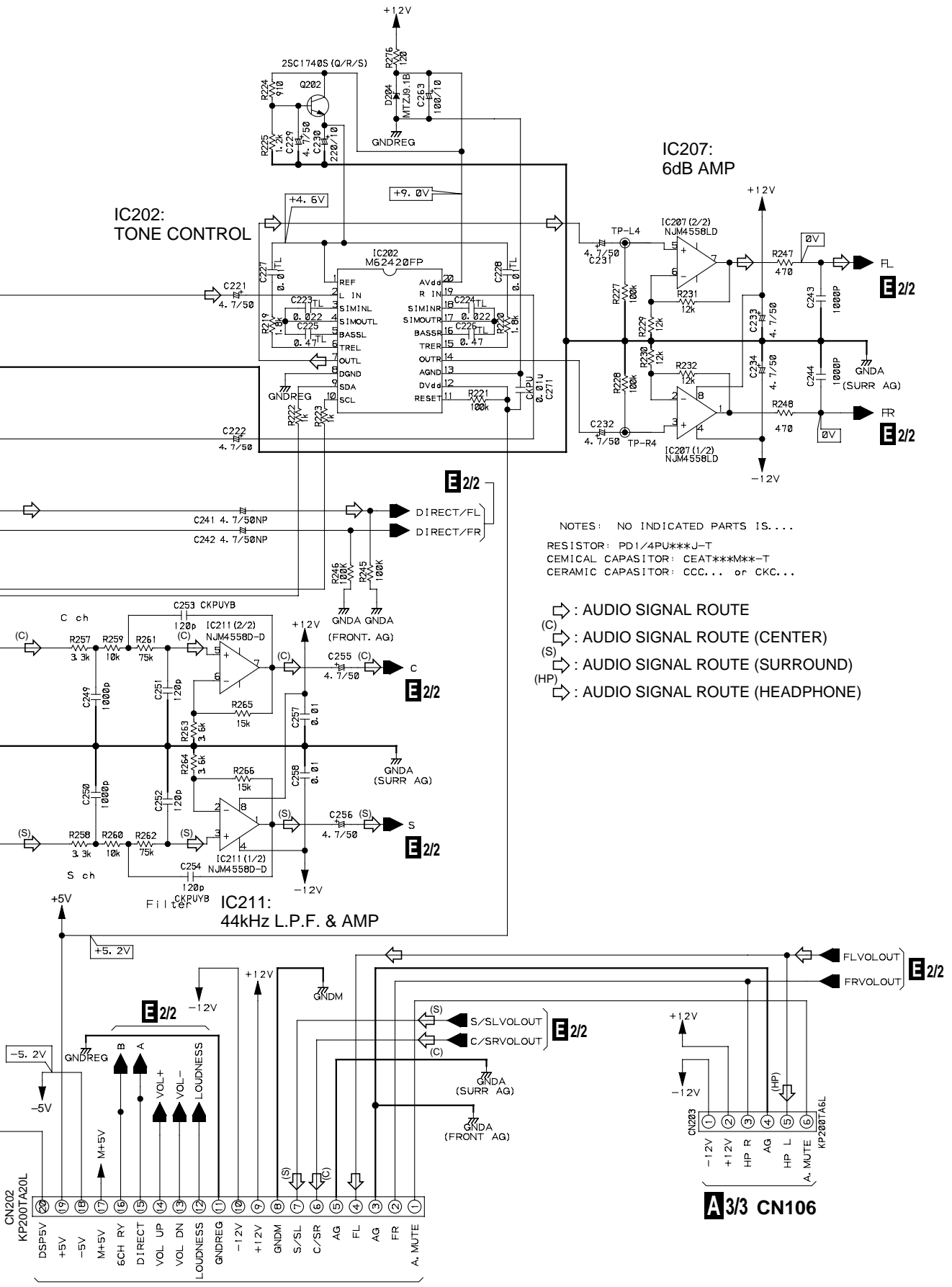

A

B

C

D

A1/3 CN107

A3/3 CN106

3.7 VOLUME DSP ASSY (2/2)

E 2/2 VOLUME DSP ASSY(AWX7064)

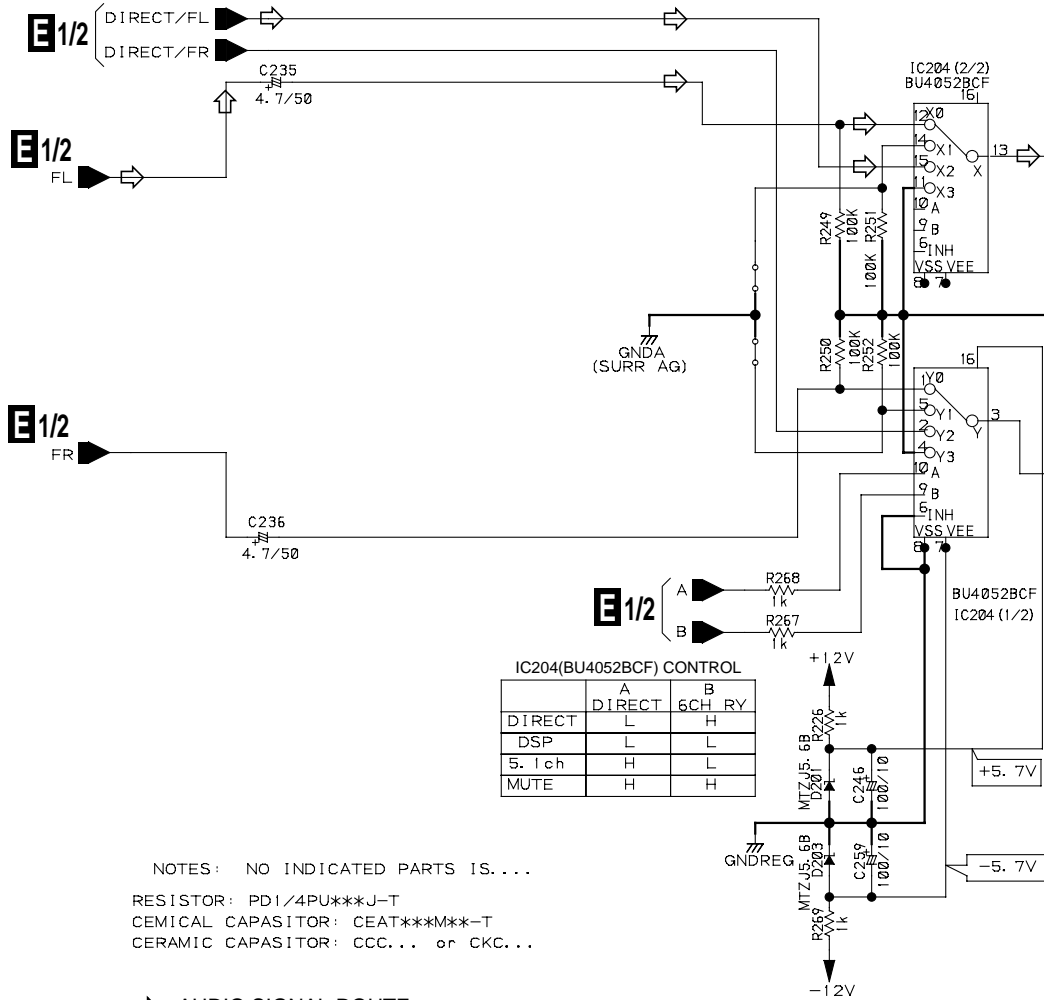

NOTES: NO INDICATED PARTS IS....
 RESISTOR: PD1/4PU***J-T
 CEMICAL CAPASITOR: CEAT***M**--T
 CERAMIC CAPASITOR: CCC... or CKC...

↳ : AUDIO SIGNAL ROUTE
 (C)↳ : AUDIO SIGNAL ROUTE (CENTER)
 (S)↳ : AUDIO SIGNAL ROUTE (SURROUND)

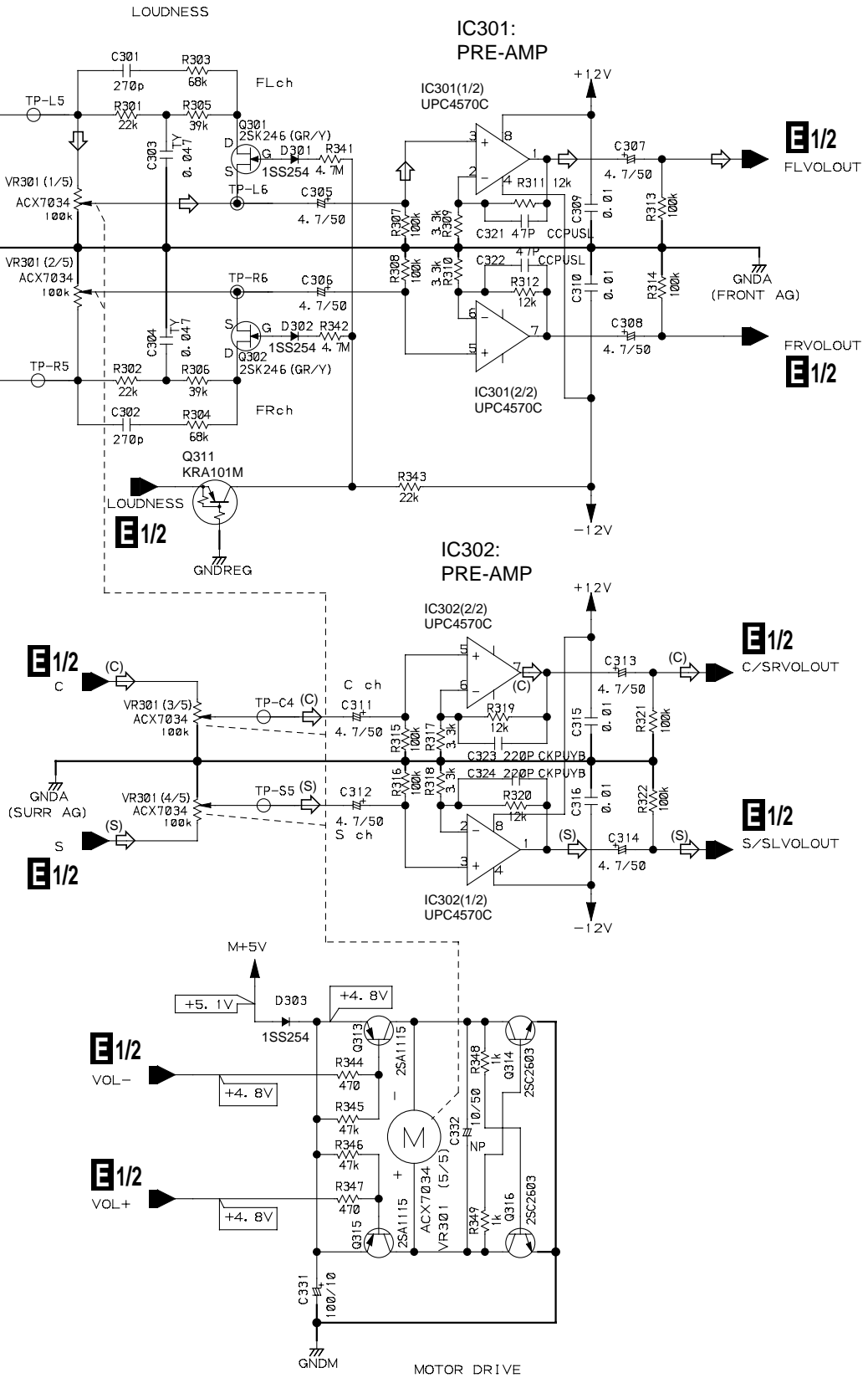

3.8 FRONT SPEAKER, HEADPHONE, PRIMARY AND TRANS 1 ASSEMBLIES

F FRONT SPEAKER ASSY (AWX7068)

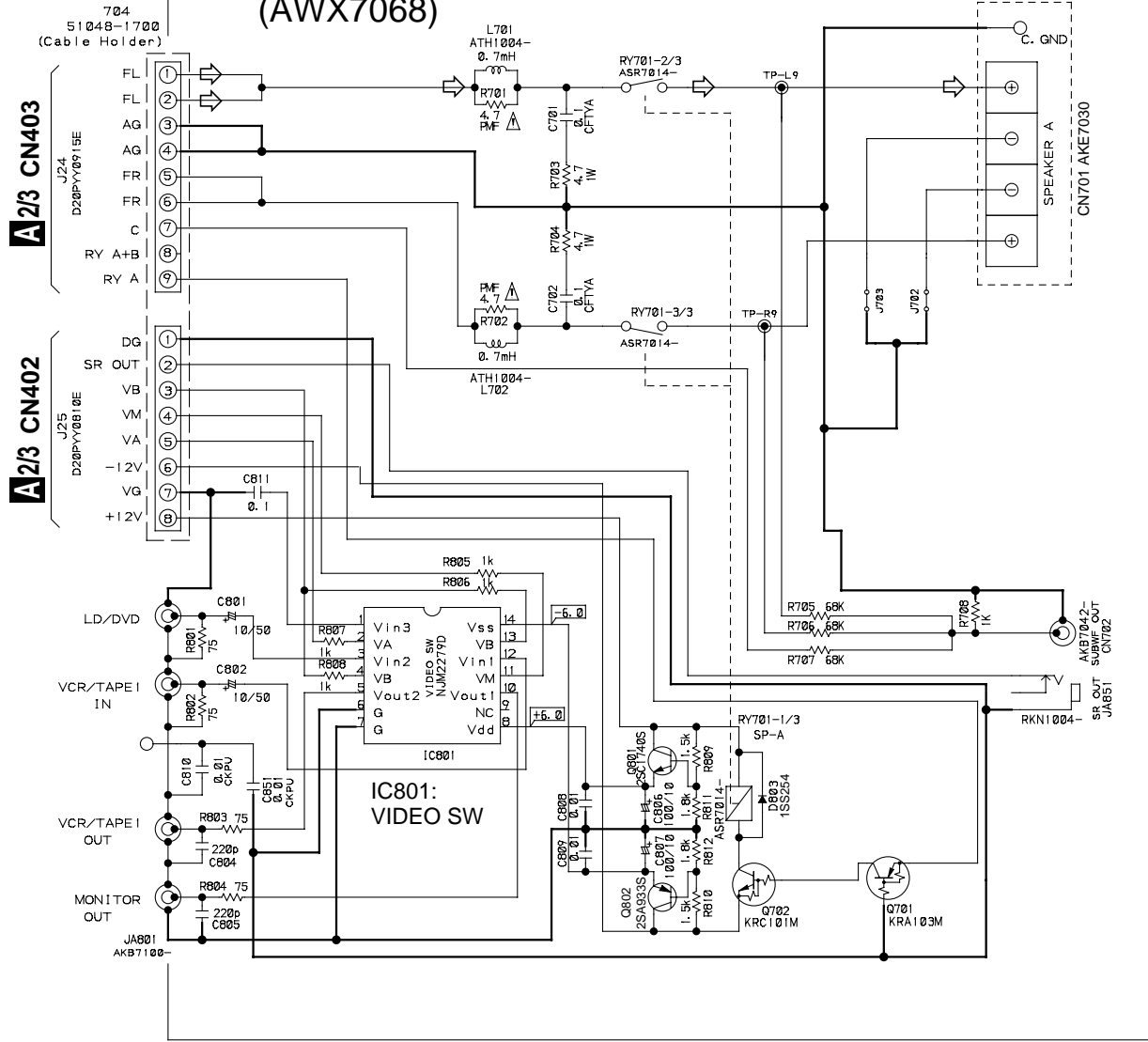

IC801(NJM2279D) LOGIC

FUNCTION	VA	VB	VM
VCR/TAPE	*(L)	L	H
LD/DVD	L	H	H
F-VIDEO	H	H	H
AUDIO	*(L)	*(L)	L

NOTES: NO INDICATED PARTS IS...
 RESISTOR: PD1/4PU***J-T
 CEMICAL CAPASITOR: CEAT***M**T
 CERAMIC CAPASITOR: CCC... or CKC...

⇨ : AUDIO SIGNAL ROUTE



• NOTE FOR FUSE REPLACEMENT

CAUTION -FOR CONTINUED PROTECTION AGAINST RISK OF FIRE. REPLACE ONLY WITH SAME TYPE AND RATINGS ONLY.

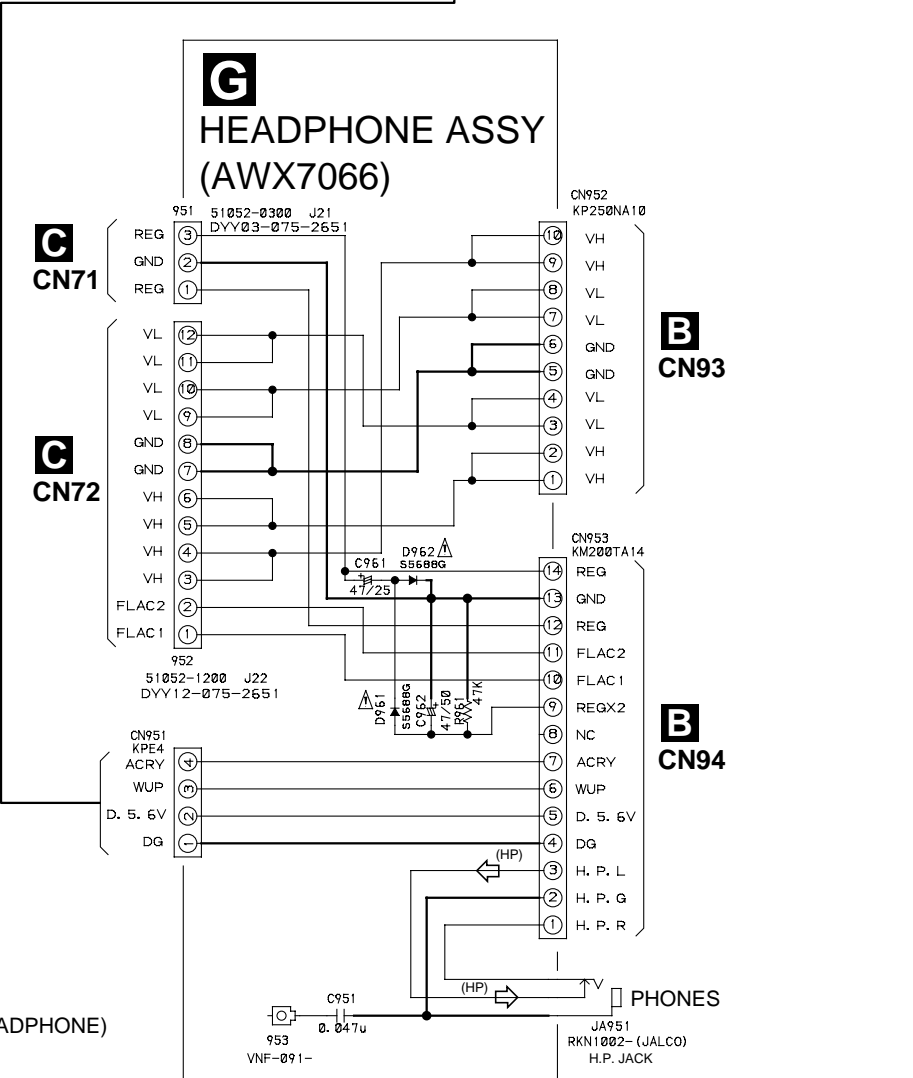
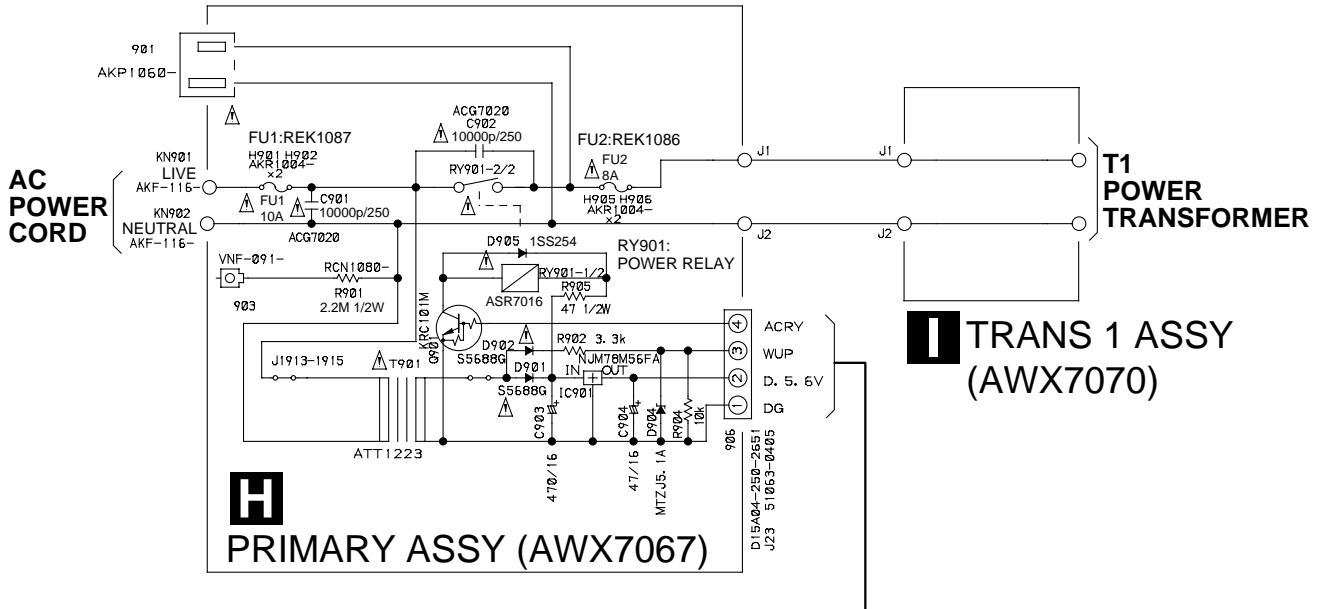

(HP) : AUDIO SIGNAL ROUTE (HEADPHONE)

4. PCB CONNECTION DIAGRAM

4.1 MOTHER ASSY

NOTE FOR PCB DIAGRAMS :

1. Part numbers in PCB diagrams match those in the schematic diagrams.
2. A comparison between the main parts of PCB and schematic diagrams is shown below.

Symbol In PCB Diagrams	Symbol In Schematic Diagrams	Part Name
		Transistor
		Transistor with resistor
		Field effect transistor
		Resistor array
		3-terminal regulator

3. The parts mounted on this PCB include all necessary parts for several destinations.
- For further information for respective destinations, be sure to check with the schematic diagram.
4. View point of PCB diagrams.

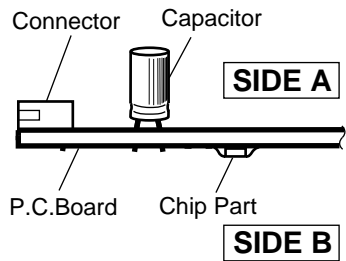

A MOTHER ASSY FM/AM TUNER UNIT E

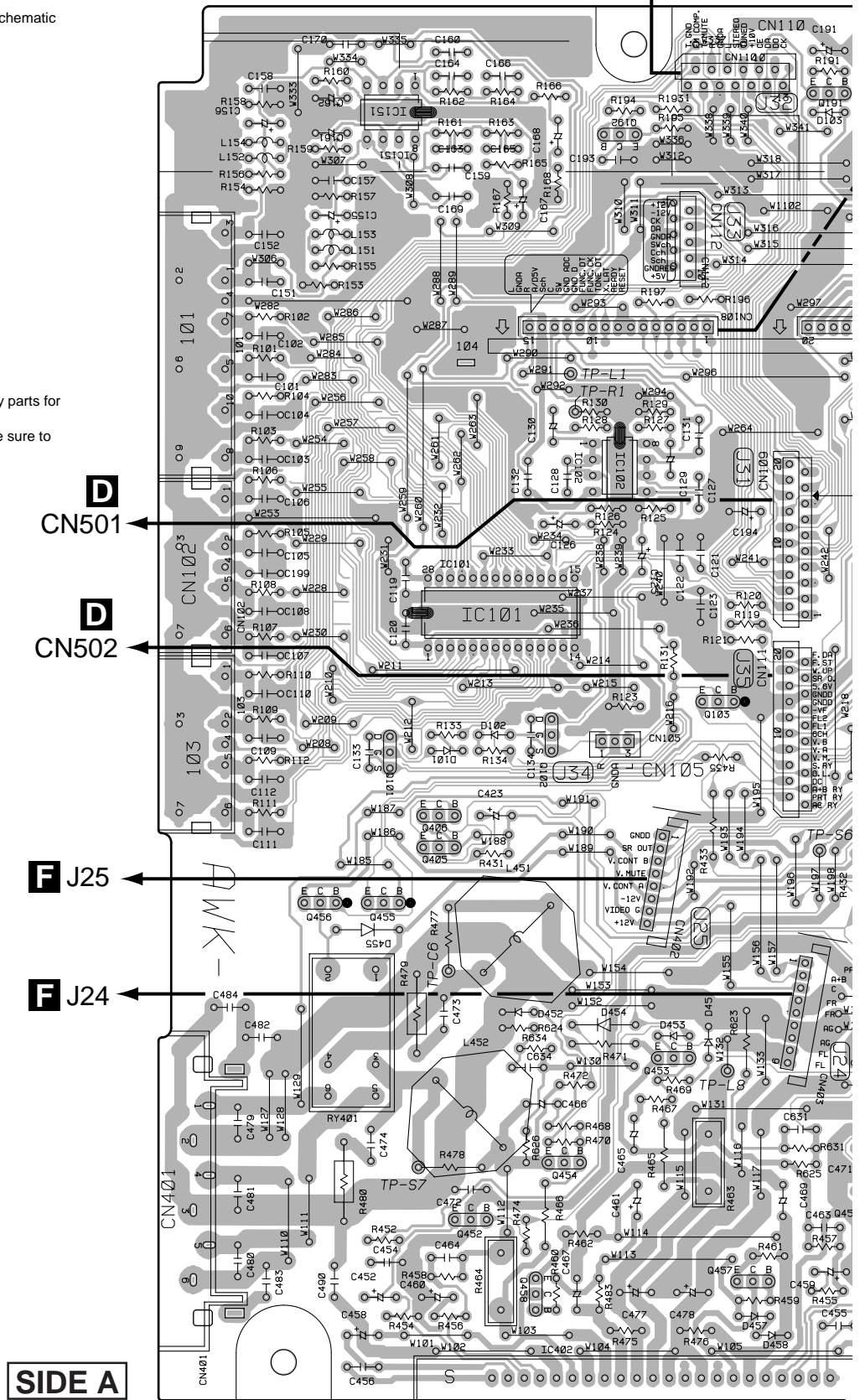

UNIT E CN201 E CN202

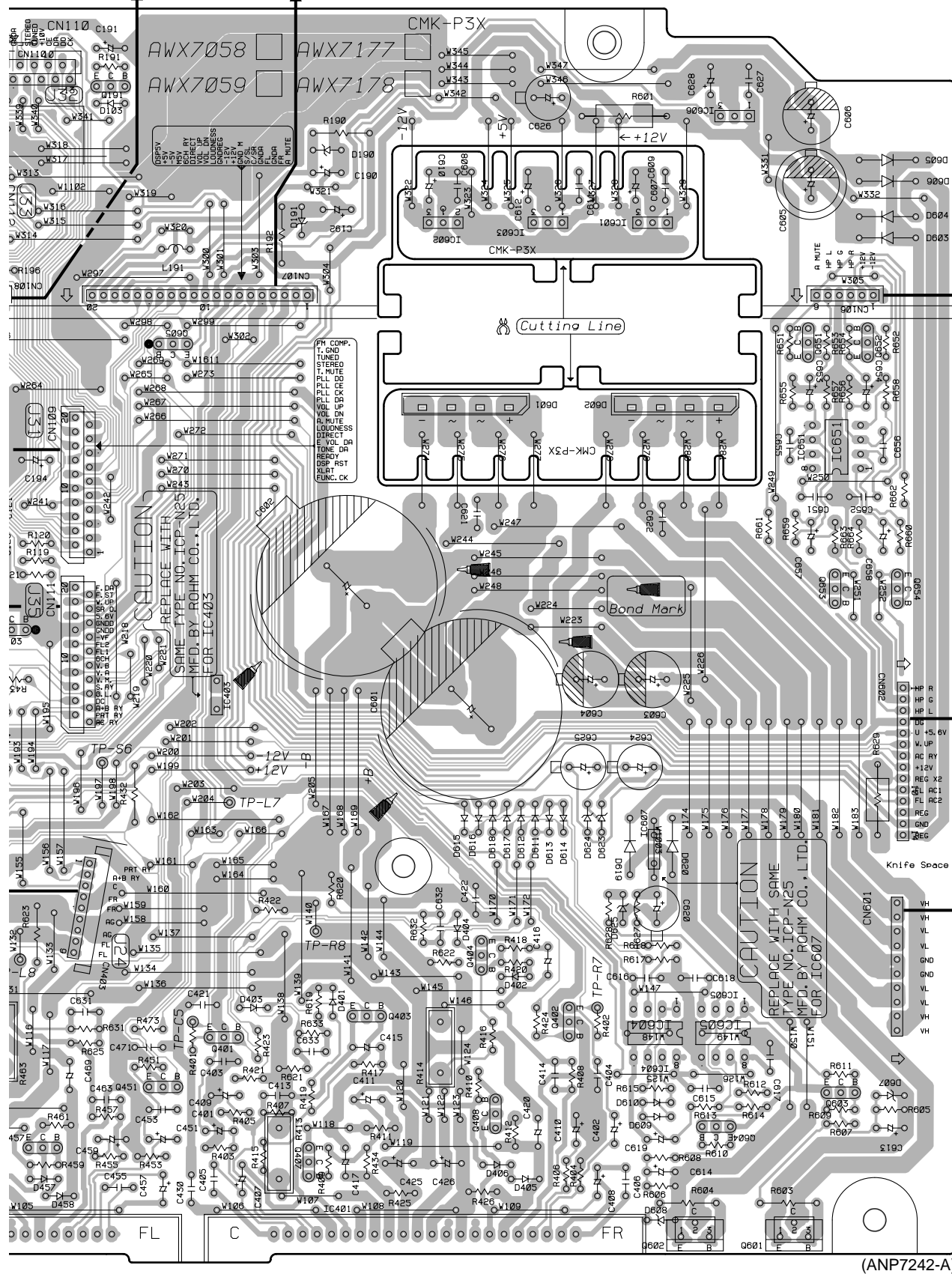

E CN203

B CN92

B CN91

191	Q605	IC601-IC603	IC607 IC606	Q651-Q654
Q457	Q451	Q402-Q404	IC604 Q604	IC651
Q401	Q407	Q408	Q602	Q601 Q603
IC401				



4.2 CONNECTION, TRANS 2 AND FRONT ASSEMBLIES

B CONNECTION ASSY

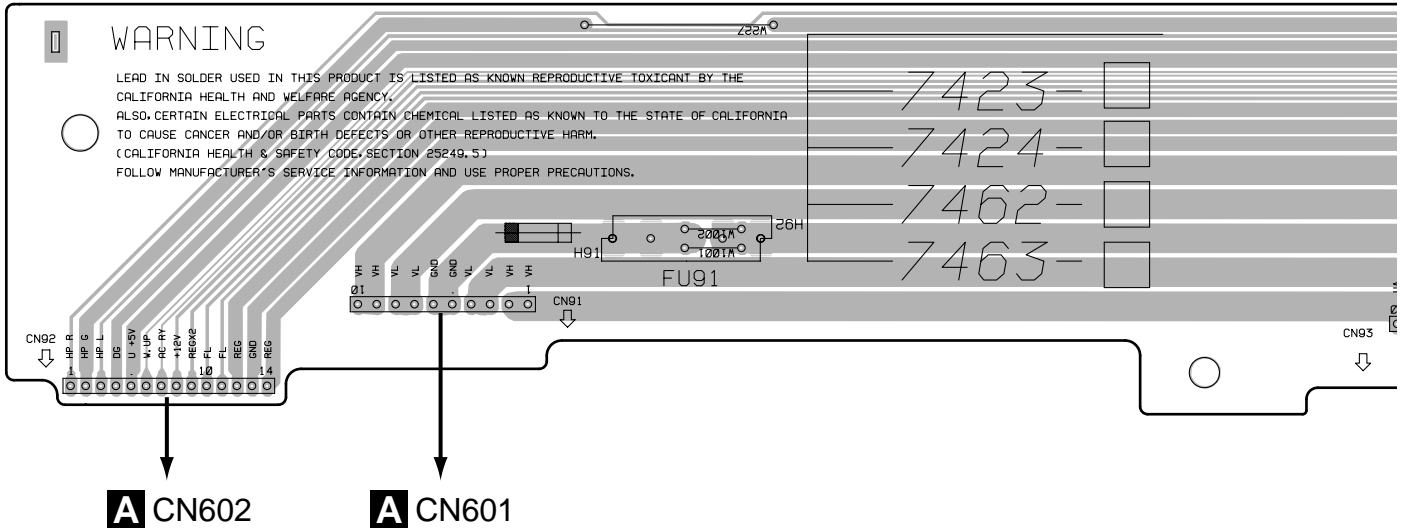

D FRONT ASSY

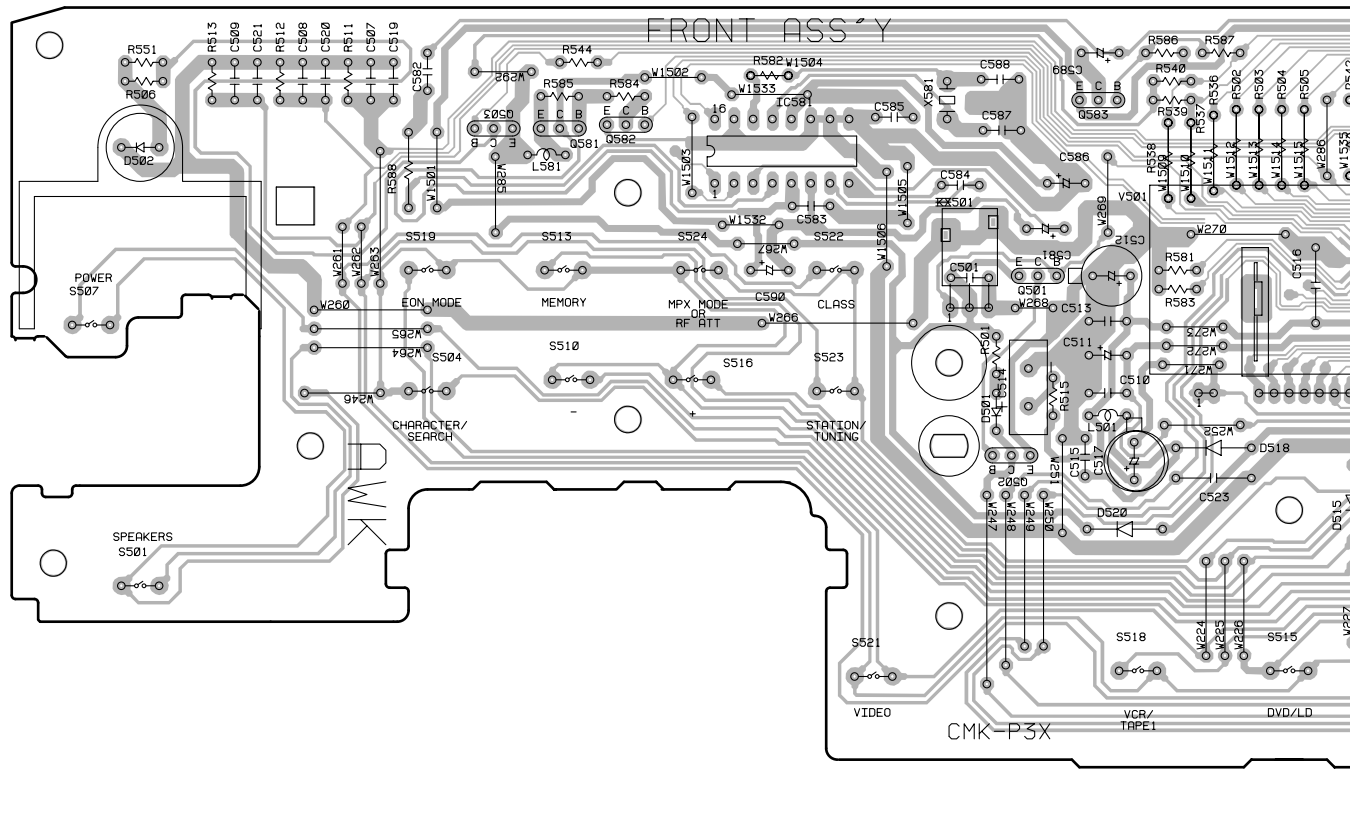

Q503 Q581 Q582 IC581 Q501 Q583 Q502

SIDE A

C TRANS 2 ASSY

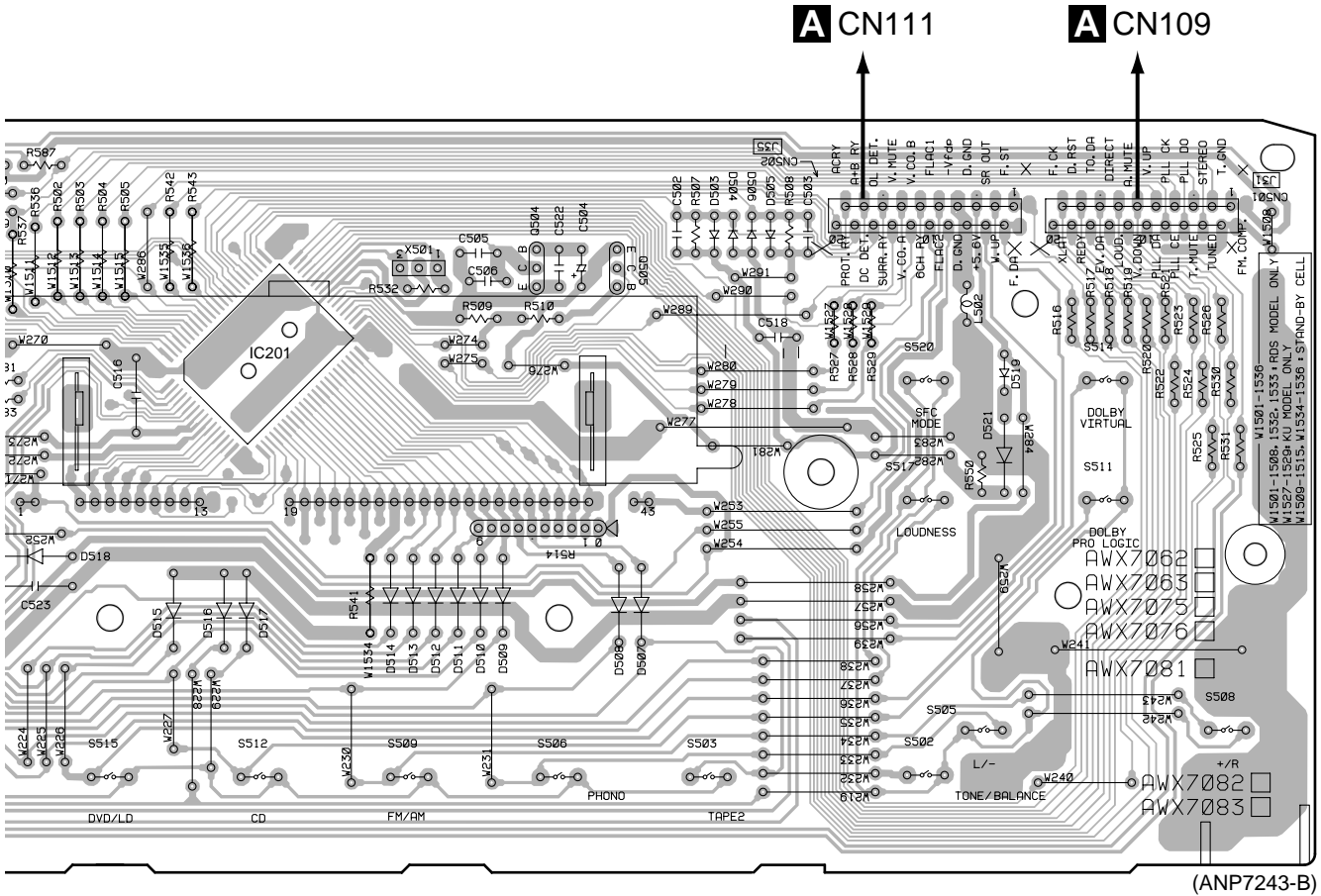
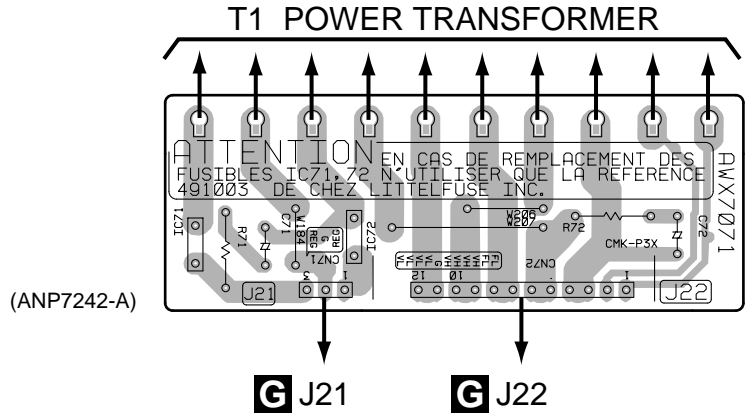
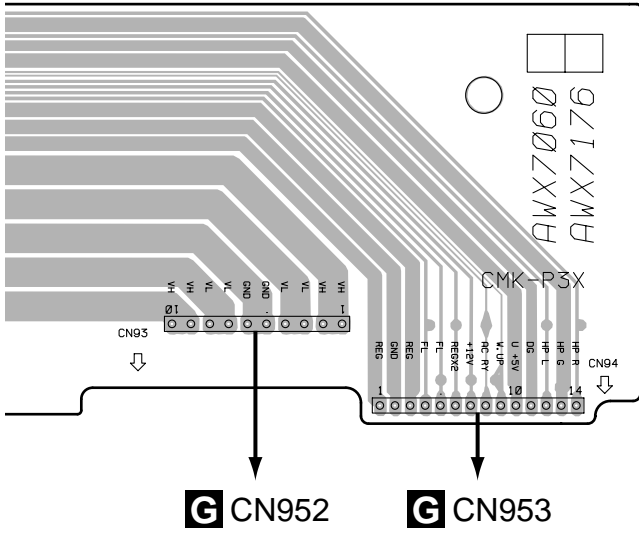

IC201

Q504 Q505

SIDE A

B C D

4.3 VOLUME DSP ASSY

E VOLUME DSP ASSY

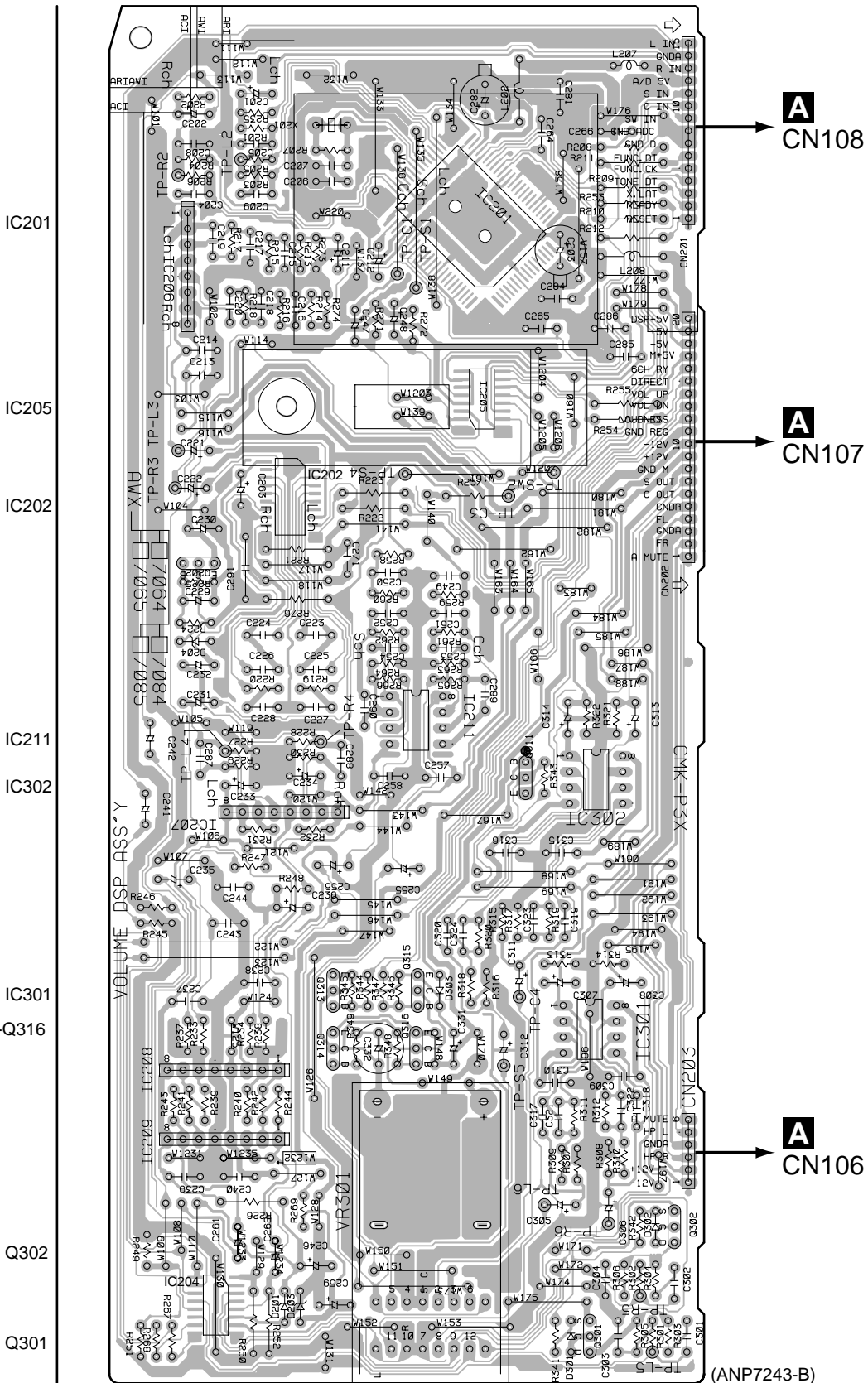

A CN108

A CN107

A CN106

(ANP7243-B)

SIDE A



4.4 FRONT SPEAKER, HEADPHONE, PRIMARY AND TRANS 1 ASSEMBLIES

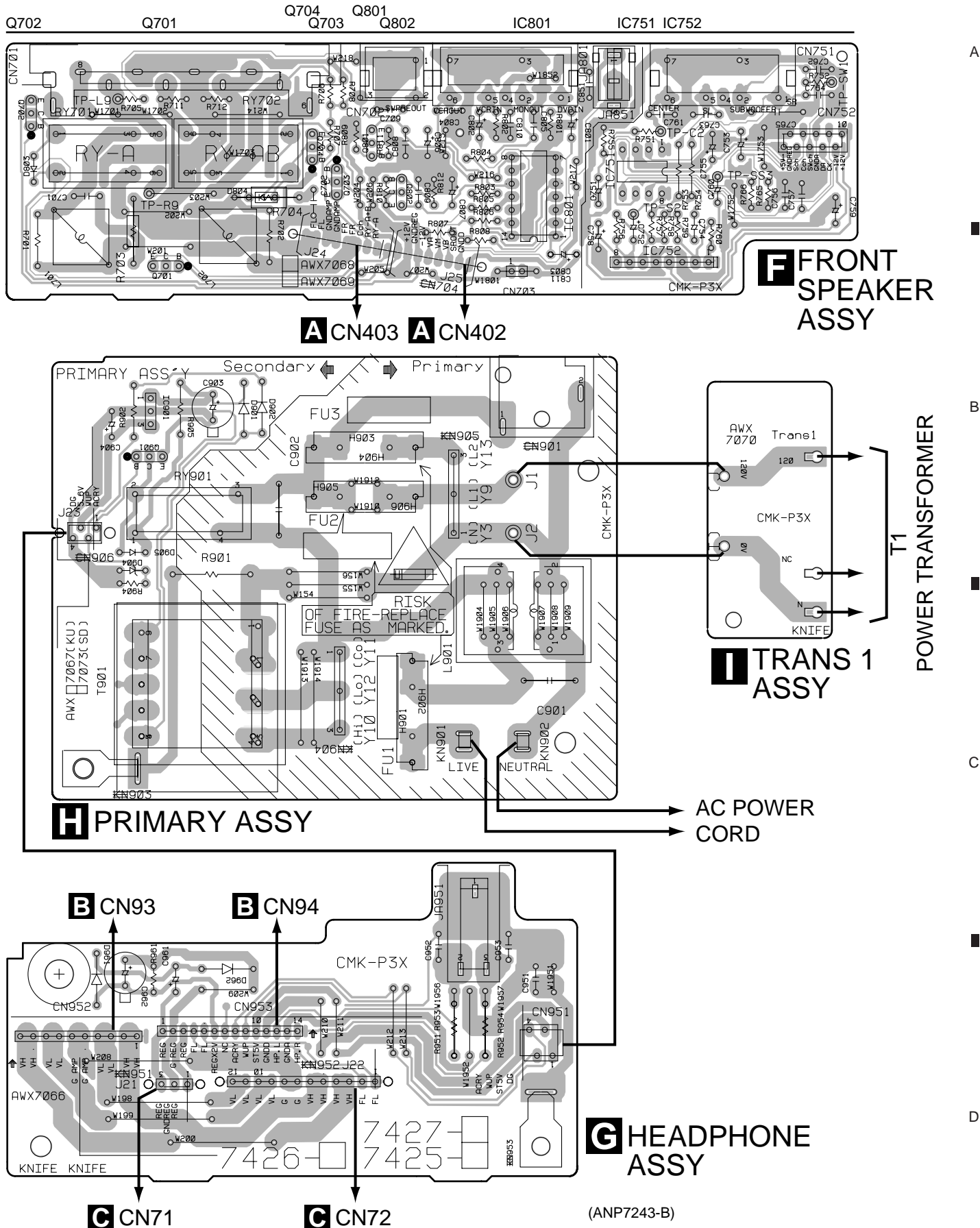

SIDE A

F G H I

5. PCB PARTS LIST

NOTES: ●Parts marked by "NSP" are generally unavailable because they are not in our Master Spare Parts List.

●The Δ mark found on some component parts indicates the importance of the safety factor of the part.

Therefore, when replacing, be sure to use parts of identical designation.

●When ordering resistors, first convert resistance values into code form as shown in the following examples.

Ex.1 When there are 2 effective digits (any digit apart from 0), such as 560 ohm and 47k ohm (tolerance is shown by J=5%, and K=10%).

560 Ω \rightarrow 56×10^1 \rightarrow 561 RD1/4PU $\boxed{5} \boxed{6} \boxed{1} J$
 47k Ω \rightarrow 47×10^3 \rightarrow 473 RD1/4PU $\boxed{4} \boxed{7} \boxed{3} J$
 0.5 Ω \rightarrow R50 RN2H $\boxed{R} \boxed{5} \boxed{0} K$
 1 Ω \rightarrow 1R0 RS1P $\boxed{1} \boxed{R} \boxed{0} K$

Ex.2 When there are 3 effective digits (such as in high precision metal film resistors).

5.62k Ω \rightarrow 562×10^1 \rightarrow 5621 RN1/4PC $\boxed{5} \boxed{6} \boxed{2} \boxed{1} F$

LIST OF WHOLE PCB ASSEMBLIES

Mark	Symbol and Description	Part No.			Remarks
		VSX-D307/KUXJ	VSX-D307/KUXJI	VSX-D307/KCXJI	
NSP	MAIN ASSY	AWK7423	AWX7423	AWK7462	
	└ MOTHER ASSY	AWX7058	AWX7058	AWX7177	
NSP	└ CONNECTION ASSY	AWX7060	AWX7060	AWX7176	
NSP	└ TRANS 2 ASSY	AWX7071	AWX7071	AWX7071	
NSP	COMPLEX ASSY	AWK7425	AWK7425	AWK7425	
	└ FRONT ASSY	AWX7062	AWX7062	AWX7062	
	└ VOLUME DSP ASSY	AWX7064	AWX7064	AWX7064	
	└ FRONT SPEAKER ASSY	AWX7068	AWX7068	AWX7068	
	└ HEADPHONE ASSY	AWX7066	AWX7066	AWX7066	
	└ PRIMARY ASSY	AWX7067	AWX7067	AWX7067	
NSP	└ TRANS 1 ASSY	AWX7070	AWX7070	AWX7070	

Mark	No.	Description	Part No.
------	-----	-------------	----------

A MOTHER ASSY

(1) CONTRAST TABLE

AWX7058 and AWX7177 are constructed the same except for the following :

Mark	Symbol and Description	Part No.		Remarks
		AWX7058	AWX7177	
Δ	IC607	Not used	ICP-N25	

(2) PARTS LIST FOR AWX7058

SEMICONDUCTORS

	IC101	E-SW IC	TC9163AN
	IC102	OP-AMP IC	NJM4558D-D
	IC151	IC	UPC4570C
Δ	IC401	AUDIO IC	PAC007A
Δ	IC402	AUDIO IC	PAC007A
Δ	IC403	IC PROTECTOR	ICP-N25
	IC601	REGULATOR IC	NJM78M12FA
	IC602	REGULATOR IC	NJM79M12FA
	IC603	REGULATOR IC	NJM78M05FA
	IC604	OP-AMP IC	NJM4558D-D
	IC605	OP-AMP IC	NJM4558D-D
	IC606	REGULATOR IC	NJM78M05FA
	IC651	OP-AMP IC	NJM4558D-D
	Q191	TRANSISTOR	2SC1740S
	Q401	TRANSISTOR	2SC2878

Mark	No.	Description	Part No.
------	-----	-------------	----------

	Q402	TRANSISTOR	2SC2878
	Q403	TRANSISTOR	2SC2240
	Q404	TRANSISTOR	2SC2240
	Q405	TRANSISTOR	2SC1740S
	Q406	TRANSISTOR	2SC1740S

	Q407	TRANSISTOR	2SC2705
	Q408	TRANSISTOR	2SC2705
	Q451	TRANSISTOR	2SC2878
	Q452	TRANSISTOR	2SC2878
	Q453	TRANSISTOR	2SC2240

	Q454	TRANSISTOR	2SC2240
	Q455	TRANSISTOR	KRA103M
	Q456	TRANSISTOR	KRC101M
	Q457	TRANSISTOR	2SC2705
	Q458	TRANSISTOR	2SC2705

	Q601	POWER MOS FET	IRF9540A
	Q602	POWER MOS FET	IRF540A
	Q603	TRANSISTOR	2SC1845
	Q604	TRANSISTOR	2SA992
	Q651	TRANSISTOR	2SC2878

	Q652	TRANSISTOR	2SC2878
	Q653	TRANSISTOR	2SC2878
	Q654	TRANSISTOR	2SC2878
	D103	DIODE	1SS254
	D190	ZENER DIODE	MTZJ5.1B

VSX-D307

Mark	No.	Description	Part No.
	C601	ELECTROLYTIC CAPACITOR (8200μF/71V)	ACH7018
	C602	ELECTROLYTIC CAPACITOR (8200μF/71V)	ACH7018
	C603	ELECT. CAPACITOR	CEAT101M2A
	C604	ELECT. CAPACITOR	CEAT101M2A
	C605	ELECT. CAPACITOR	CEAT222M25
	C606	ELECT. CAPACITOR	CEAT102M25
	C607	CERAMIC CAPACITOR	CKCYF103Z50
	C608	CERAMIC CAPACITOR	CKCYF103Z50
	C609	ELECT. CAPACITOR	CEAT101M25
	C610	ELECT. CAPACITOR	CEAT101M25
	C611	CERAMIC CAPACITOR	CKCYF103Z50
	C612	ELECT. CAPACITOR	CEAT470M10
	C613	ELECT. CAPACITOR	CEAT1R0M50
	C614	ELECT. CAPACITOR	CEAT1R0M50
	C615	CERAMIC CAPACITOR	CKCYF103Z50
	C616	CERAMIC CAPACITOR	CKCYF103Z50
	C617	CERAMIC CAPACITOR	CKCYF103Z50
	C618	CERAMIC CAPACITOR	CKCYF103Z50
	C619	ELECT. CAPACITOR	CEAT4R7M50
	C620	ELECT. CAPACITOR	CEAT470M50
	C621	CKA (0.01μF/AC250V)	ACG1005
	C622	CKA (0.01μF/AC250V)	ACG1005
	C624	ELECT. CAPACITOR	CEAT101M35
	C625	ELECT. CAPACITOR	CEAT101M10
	C626	ELECT. CAPACITOR	CEAT221M25
	C627	CERAMIC CAPACITOR	CKCYF103Z50
	C628	ELECT. CAPACITOR	CEAT470M10
	C631	FILM CAPACITOR	CFTLA334J50
	C632	FILM CAPACITOR	CFTLA334J50
	C633	FILM CAPACITOR	CFTLA334J50
	C634	FILM CAPACITOR	CFTLA334J50
	C651	CERAMIC CAPACITOR	CKCYF103Z50
	C652	CERAMIC CAPACITOR	CKCYF103Z50
	C653	ELECT. CAPACITOR	CEAT100M50
	C654	ELECT. CAPACITOR	CEAT100M50
	C657	ELECT. CAPACITOR	CEAT101M16
	C658	ELECT. CAPACITOR	CEAT101M16

RESISTORS

	R190	CARBON FILM RESISTOR	RD1/2PM391J
△	R411	CARBON FILM RESISTOR	RD1/4MUF820J
△	R412	CARBON FILM RESISTOR	RD1/4MUF820J
△	R413	RESISTOR (0.22Ω, 5W)	ACN7035
△	R414	RESISTOR (0.22Ω, 5W)	ACN7035
△	R425	CARBON FILM RESISTOR	RD1/4MUF331J
△	R426	CARBON FILM RESISTOR	RD1/4MUF331J
△	R461	CARBON FILM RESISTOR	RD1/4MUF820J
△	R462	CARBON FILM RESISTOR	RD1/4MUF820J
△	R463	RESISTOR (0.22Ω, 5W)	ACN7035
△	R464	RESISTOR (0.22Ω, 5W)	ACN7035
△	R475	CARBON FILM RESISTOR	RD1/4MUF331J
△	R476	CARBON FILM RESISTOR	RD1/4MUF331J
△	R477	CARBON FILM RESISTOR	RD1/4PMF4R7J
△	R478	CARBON FILM RESISTOR	RD1/4PMF4R7J
	R479	METAL OXIDE RESISTOR	RS1LMF4R7J
	R480	METAL OXIDE RESISTOR	RS1LMF4R7J
	R601	METAL OXIDE RESISTOR	RS2LMF330J
△	R603	CARBON FILM RESISTOR	RD1/4PMF101J
△	R604	CARBON FILM RESISTOR	RD1/4PMF101J

Mark	No.	Description	Part No.
△	R629	METAL OXIDE RESISTOR	RS1LMF561J
△	R663	CARBON FILM RESISTOR	RD1/4MUF330J
△	R664	CARBON FILM RESISTOR	RD1/4MUF330J
		Other Resistors	RD1/4PU□□□J

OTHERS

101	PIN JACK(6P)	AKB7013
103	PIN JACK(4P)	AKB7014
CN102	PIN JACK(4P)	AKB7015
CN106	6P PLUG	KM200TA6
CN107	20P PLUG	KM200TA20
CN108	15P PLUG	KM200TA15
CN109	20P CONNECTOR	52045-2045
CN110	CONNECTOR	52045-1345
CN111	20P CONNECTOR	52045-2045
CN401	SPEAKER TERMINAL 6-P	AKE1053
CN402	8P JUMPER CONNECTOR	52147-0810
CN403	9P JUMPER CONNECTOR	52147-0910
CN601	10P SOCKET	KP250NA10
CN602	14P PLUG	KM200TA14

B CONNECTION ASSY

(1) CONTRAST TABLE

AWX7060 and AWX7176 are constructed the same except for the following :

Mark	Symbol and Description	Part No.		Remarks
		AWX7060	AWX7176	
	H91,H92 Fuse Clip	Not used	AKR1004	

(2) PARTS LIST FOR AWX7060

OTHERS

CN91	10P PLUG	KM250NA10L
CN92	14P SOCKET	KP200TA14L
CN93	10P PLUG	KM250NA10L
CN94	14P SOCKET	KP200TA14L

C TRANS 2 ASSY

SEMICONDUCTORS

△	IC71	PROTECTOR(3A)	AEK7015
△	IC72	PROTECTOR(3A)	AEK7015

OTHERS

CN71	3P JUMPER CONNECTOR	KPD3
CN72	12P JUMPER CONNECTOR	KPD12

COMPLEX ASSY

OTHERS

J1	LEAD WIRE UNIT	DB115NB0
----	----------------	----------

Mark	No.	Description	Part No.
D	FRONT ASSY		
SEMICONDUCTORS			
	IC501	CONTROL MCU	PDG211A
	Q501	TRANSISTOR	KRA101M
	Q502	TRANSISTOR	KRC101M
	Q503	TRANSISTOR	KRA103M
	Q504	TRANSISTOR	KRC101M
	Q505	TRANSISTOR	2SA933S
	D501	DIODE	1SS254
	D502	LED	BR3371XJ30A
	D503	DIODE	1SS254
	D504	DIODE	1SS254
	D505	DIODE	1SS254
	D506	DIODE	1SS254
	D507	DIODE	1SS254
	D508	DIODE	1SS254
	D509	DIODE	1SS254
	D510	DIODE	1SS254
	D511	DIODE	1SS254
	D512	DIODE	1SS254
	D513	DIODE	1SS254
	D514	DIODE	1SS254
	D518	DIODE	1SS254
	D519	DIODE	1SS254
	D520	DIODE	1SS254
	D521	DIODE	1SS254
SWITCHES			
	S501	SWITCH	ASG1034
	S502	SWITCH	ASG1034
	S503	SWITCH	ASG1034
	S505	SWITCH	ASG1034
	S506	SWITCH	ASG1034
	S507	SWITCH	ASG1034
	S508	SWITCH	ASG1034
	S509	SWITCH	ASG1034
	S510	SWITCH	ASG1034
	S511	SWITCH	ASG1034
	S512	SWITCH	ASG1034
	S513	SWITCH	ASG1034
	S514	SWITCH	ASG1034
	S515	SWITCH	ASG1034
	S516	SWITCH	ASG1034
	S517	SWITCH	ASG1034
	S518	SWITCH	ASG1034
	S520	SWITCH	ASG1034
	S522	SWITCH	ASG1034
	S523	SWITCH	ASG1034
	S524	SWITCH	ASG1034
COILS			
	L501	AXIAL INDUCTOR	LAU2R2J
	L502	AXIAL INDUCTOR	LAUR22J
CAPACITORS			
	C501	CERAMIC CAPACITOR	CKPUYF103Z25
	C502	CERAMIC CAPACITOR	CKPUYF103Z25
	C503	CERAMIC CAPACITOR	CKPUYF473Z16
	C504	ELECT. CAPACITOR	CEAT2R2M50
	C505	CERAMIC CAPACITOR	CGCYX104M16

Mark	No.	Description	Part No.
	C507	AXIAL CAPACITOR	CKPUYB101K50
	C508	AXIAL CAPACITOR	CKPUYB101K50
	C509	AXIAL CAPACITOR	CKPUYB101K50
	C510	CERAMIC CAPACITOR	CKCYF103Z50
	C511	ELECT. CAPACITOR	CEAT470M50
	C512	ELECT. CAPACITOR	CEAT221M10
	C513	CERAMIC CAPACITOR	CGCYX103M16
	C514	CAPACITOR	ACH7013
	C516	CERAMIC CAPACITOR	CKPUYF473Z16
	C517	ELECT. CAPACITOR	CEAT221M35
	C518	AUDIO FILM CAPACITOR	CFTYA104J50
	C522	CERAMIC CAPACITOR	CKPUYF473Z16
	C523	CERAMIC CAPACITOR	CKPUYB102K50

RESISTORS

All Resistors

RD1/4PU□□□J

OTHERS

501	REMOTE RECEIVER UNIT	GP1U27X
CN501	20P CONNECTOR	52044-2045
CN502	20P CONNECTOR	52044-2045
V501	FL TUBE	AAV7053
X501	CERAMIC RESONATOR (7.2MHz)	ASS7018

E VOLUME DSP ASSY**SEMICONDUCTORS**

IC201	DSP IC	CXD2724Q
IC202	E-VR IC	M62420FP
IC204	LOGIC IC	BU4052BCF
IC206	OP-AMP IC	NJM4558LD
IC207	OP-AMP IC	NJM4558LD
IC211	OP-AMP IC	NJM4558D-D
IC301	IC	UPC4570C
IC302	IC	UPC4570C
Q202	TRANSISTOR	2SC1740S
Q301	N-FET	2SK246
Q302	N-FET	2SK246
Q311	TRANSISTOR	KRA101M
Q313	TRANSISTOR	2SA1115
Q314	TRANSISTOR	2SC2603
Q315	TRANSISTOR	2SA1115
Q316	TRANSISTOR	2SC2603
D201	ZENER DIODE	MTZJ5.6B
D203	ZENER DIODE	MTZJ5.6B
D204	ZENER DIODE	MTZJ9.1B
D301	DIODE	1SS254
D302	DIODE	1SS254
D303	DIODE	1SS254

COILS

L202	AXIAL INDUCTOR	LAU1R0J
L207	AXIAL INDUCTOR	LAU220J
L208	AXIAL INDUCTOR	LAU1R0J

CAPACITORS

C201	ELECT. CAPACITOR	CEAT470M16
C202	ELECT. CAPACITOR	CEAT470M16
C203	ELECT. CAPACITOR	CEAT471M6R3
C204	CERAMIC CAPACITOR	CCCSL101J50
C205	CERAMIC CAPACITOR	CKPUYB331K50

VSX-D307

Mark	No.	Description	Part No.
	C206	AXIAL CERAMIC C.	CCPUCH120J50
	C207	AXIAL CERAMIC C.	CCPUCH120J50
	C208	CERAMIC CAPACITOR	CKPUYB331K50
	C209	CERAMIC CAPACITOR	CCCSL101J50
	C211	ELECT. CAPACITOR	CEATR22M50
	C212	ELECT. CAPACITOR	CEATR22M50
	C213	CERAMIC CAPACITOR	CKCYF103Z50
	C214	CERAMIC CAPACITOR	CKCYF103Z50
	C215	CERAMIC CAPACITOR	CKPUYB102K50
	C216	CERAMIC CAPACITOR	CKPUYB102K50
	C217	CERAMIC CAPACITOR	CKPUYB331K50
	C218	CERAMIC CAPACITOR	CKPUYB331K50
	C219	CERAMIC CAPACITOR	CKPUYB331K50
	C220	CERAMIC CAPACITOR	CKPUYB331K50
	C221	ELECT. CAPACITOR	CEAT4R7M50
	C222	ELECT. CAPACITOR	CEAT4R7M50
	C223	FILM CAPACITOR	CFTLA223J50
	C224	FILM CAPACITOR	CFTLA223J50
	C225	FILM CAPACITOR	CFTLA474J50
	C226	FILM CAPACITOR	CFTLA474J50
	C227	FILM CAPACITOR	CFTLA103J50
	C228	FILM CAPACITOR	CFTLA103J50
	C229	ELECT. CAPACITOR	CEAT4R7M50
	C230	ELECT. CAPACITOR	CEAT221M10
	C231	ELECT. CAPACITOR	CEAT4R7M50
	C232	ELECT. CAPACITOR	CEAT4R7M50
	C233	ELECT. CAPACITOR	CEAT4R7M50
	C234	ELECT. CAPACITOR	CEAT4R7M50
	C235	ELECT. CAPACITOR	CEAT4R7M50
	C236	ELECT. CAPACITOR	CEAT4R7M50
	C241	ELECT. CAPACITOR	CEANP4R7M50
	C242	ELECT. CAPACITOR	CEANP4R7M50
	C243	CERAMIC CAPACITOR	CGCYX102K25
	C244	CERAMIC CAPACITOR	CGCYX102K25
	C246	ELECT. CAPACITOR	CEAT101M10
	C247	ELECT. CAPACITOR	CEAT1R0M50
	C248	ELECT. CAPACITOR	CEAT1R0M50
	C249	CERAMIC CAPACITOR	CGCYX102K25
	C250	CERAMIC CAPACITOR	CGCYX102K25
	C251	CERAMIC CAPACITOR	CCCSL121J50
	C252	CERAMIC CAPACITOR	CCCSL121J50
	C253	CERAMIC CAPACITOR	CKPUYB121K50
	C254	CERAMIC CAPACITOR	CKPUYB121K50
	C255	ELECT. CAPACITOR	CEAT4R7M50
	C256	ELECT. CAPACITOR	CEAT4R7M50
	C257	CERAMIC CAPACITOR	CKCYF103Z50
	C258	CERAMIC CAPACITOR	CKCYF103Z50
	C259	ELECT. CAPACITOR	CEAT101M10
	C263	ELECT. CAPACITOR	CEAT101M10
	C264	AXIAL CAPACITOR	CKPUYB101K50
	C265	CERAMIC CAPACITOR	CCCSL101J50
	C266	AXIAL CAPACITOR	CKPUYB101K50
	C271	CERAMIC CAPACITOR	CKPUYF103Z25
	C282	ELECT. CAPACITOR	CEAT471M6R3
	C284	CERAMIC CAPACITOR	CGCYX102K25
	C301	CERAMIC CAPACITOR	CCCSL271J50
	C302	CERAMIC CAPACITOR	CCCSL271J50
	C303	AUDIO FILM CAPACITOR	CFTYA473J50
	C304	AUDIO FILM CAPACITOR	CFTYA473J50
	C305	ELECT. CAPACITOR	CEAT4R7M50

Mark	No.	Description	Part No.
	C306	ELECT. CAPACITOR	CEAT4R7M50
	C307	ELECT. CAPACITOR	CEAT4R7M50
	C308	ELECT. CAPACITOR	CEAT4R7M50
	C309	CERAMIC CAPACITOR	CKCYF103Z50
	C310	CERAMIC CAPACITOR	CKCYF103Z50
	C311	ELECT. CAPACITOR	CEAT4R7M50
	C312	ELECT. CAPACITOR	CEAT4R7M50
	C313	ELECT. CAPACITOR	CEAT4R7M50
	C314	ELECT. CAPACITOR	CEAT4R7M50
	C315	CERAMIC CAPACITOR	CKCYF103Z50
	C316	CERAMIC CAPACITOR	CKCYF103Z50
	C321	AXIAL CAPACITOR	CCPUSL470J50
	C322	AXIAL CAPACITOR	CCPUSL470J50
	C323	AXIAL CAPACITOR	CKPUYB221K50
	C324	AXIAL CAPACITOR	CKPUYB221K50
	C331	ELECT. CAPACITOR	CEAT101M10
	C332	ELECT. CAPACITOR	CEANP100M50

RESISTORS

VR301	VARIABLE RESISTOR	ACX7034
Other Resistors		RD1/4PU□□□□

OTHERS

CN201	15P SOCKET	KP200TA15L
CN202	20P SOCKET	KP200TA20L
CN203	6P SOCKET	KP200TA6L
X201	XTAL RES (OSC)	ASS7002

F FRONT SPEAKER ASSY

SEMICONDUCTORS

IC801	VIDEO SW IC	NJM2279D
Q701	TRANSISTOR	KRA103M
Q702	TRANSISTOR	KRC101M
Q801	TRANSISTOR	2SC1740S
Q802	TRANSISTOR	2SA933S
D803	DIODE	1SS254

RELAY

RY701	RELAY	ASR7014
-------	-------	---------

COILS

L701	COIL (0.7mH)	ATH1004
L702	COIL (0.7mH)	ATH1004

CAPACITORS

C701	AUDIO FILM CAPACITOR	CFTYA104J50
C702	AUDIO FILM CAPACITOR	CFTYA104J50
C801	ELECT. CAPACITOR	CEAT100M50
C802	ELECT. CAPACITOR	CEAT100M50
C804	CERAMIC CAPACITOR	CCCSL221J50
C805	CERAMIC CAPACITOR	CCCSL221J50
C806	ELECT. CAPACITOR	CEAT101M10
C807	ELECT. CAPACITOR	CEAT101M10
C808	CERAMIC CAPACITOR	CKCYF103Z50
C809	CERAMIC CAPACITOR	CKCYF103Z50
C810	CERAMIC CAPACITOR	CKPUYF103Z25
C811	CERAMIC CAPACITOR	CGCYX104M16
C851	CERAMIC CAPACITOR	CKPUYF103Z25

Mark	No.	Description	Part No.
RESISTORS			
△	R701	CARBON FILM RESISTOR	RD1/4PMF4R7J
△	R702	CARBON FILM RESISTOR	RD1/4PMF4R7J
	R703	METAL OXIDE RESISTOR	RS1LMF4R7J
	R704	METAL OXIDE RESISTOR	RS1LMF4R7J
	Other Resistors		RD1/4PU□□□J

OTHERS

	CN701	SPEAKER TERMINAL 4-P	AKE7030
	CN702	PIN JACK 1-P	AKB7042
	J24	JUMPER WIRE 9P	D20PYY0915E
	J25	JUMPER WIRE 8P	D20PYY0810E
	JA801	PIN JACK(4P)YELLOW	AKB7100
	JA851	JACK	RKN1004

G HEADPHONE ASSY**SEMICONDUCTORS**

△	D961	DIODE	S5688G
△	D962	DIODE	S5688G

CAPACITORS

	C951	CERAMIC CAPACITOR	CGCYF473Z50
	C961	ELECT. CAPACITOR	CEAT470M25
	C962	ELECT. CAPACITOR	CEAT470M50

RESISTOR

	R961	CARBON FILM RESISTOR	RD1/4PU473J
--	------	----------------------	-------------

OTHERS

	CN951	CONNECTOR(4P)	KPE4
	CN952	10P SOCKET	KP250NA10
	CN953	14P PLUG	KM200TA14
	951	CABLE HOLDER(3P)	51052-0300
	952	CABLE HOLDER(12P)	51052-1200
	953	GROUND PLATE	VNF-091
	JA951	JACK	RKN1002

H PRIMARY ASSY**SEMICONDUCTORS**

	IC901	REGULATOR IC	NJM78M56FA
	Q901	TRANSISTOR	KRC101M
△	D901	DIODE	S5688G
△	D902	DIODE	S5688G
	D904	ZENER DIODE	MTZJ5.1A
	D905	DIODE	1SS254

RELAY

△	RY901	LOWPOWER RELAY	ASR7016
---	-------	----------------	---------

TRANSFORMER

△	T901	POWER TRANSFORMER	ATT1223
---	------	-------------------	---------

CAPACITORS

△	C901	CKA (10000pF/AC250V)	ACG7020
△	C902	CKA (10000pF/AC250V)	ACG7020
	C903	ELECT. CAPACITOR	CEAT471M16
	C904	ELECT. CAPACITOR	CEAT470M16

Mark	No.	Description	Part No.
RESISTORS			
	R901	RESISTOR(2.2MΩ, 1/2W)	RCN1080
	R902	CARBON FILM RESISTOR	RD1/4PU332J
	R904	CARBON FILM RESISTOR	RD1/4PU103J
	R905	CARBON FILM RESISTOR	RD1/2PM470J

OTHERS

	901	AC SOCKET 1-P	AKP1060
	903	GROUND PLATE	VNF-091
	906	CABLE HOLDER(4P)	51063-0405
	H901	FUSE CLIP	AKR1004
	H902	FUSE CLIP	AKR1004
	H905	FUSE CLIP	AKR1004
	H906	FUSE CLIP	AKR1004

I TRANS 1 ASSY

No service parts.

6. ADJUSTMENT

There is no information to be shown in this chapter.

7. GENERAL INFORMATION

7.1 PARTS

7.1.1 IC

• The information shown in the list is basic information and may not correspond exactly to that shown in the schematic diagrams.

■ CXD2724Q (VOLUME DSP ASSY : IC201)

• DSP IC

●Block Diagram

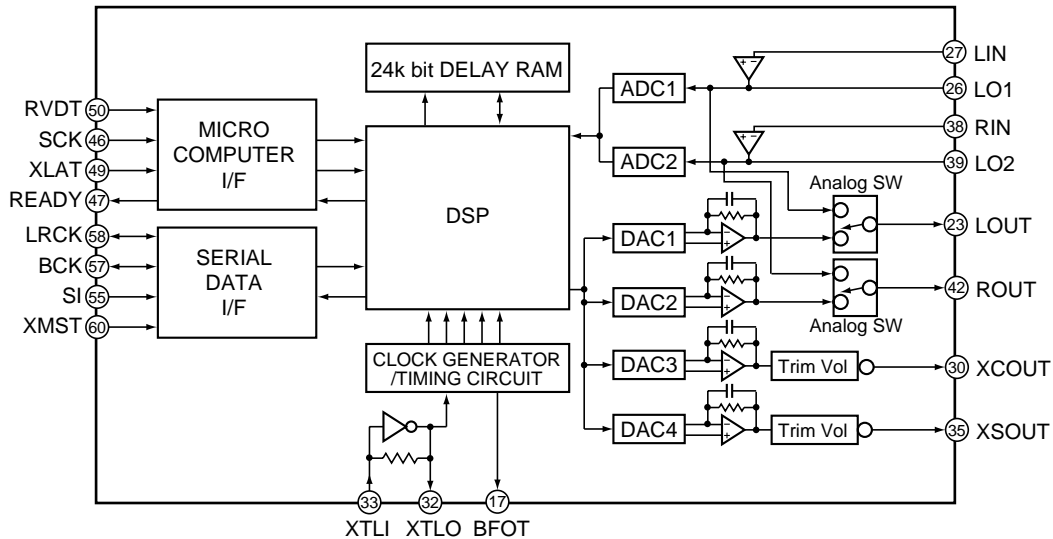

●Pin Function

No.	Pin Name	I/O	Function
1-3	T.P	O	Monitor pin for test Normally, outputs "L".
4	VSS0	-	Digital ground
5-8	T.P	O	Monitor pin for test Normally, outputs "L".
9	TST0	I	Test pin Normally, fix to L.
10	VDD0	-	Digital power supply
11	VSS1	-	Digital ground
12	TST1	I	Test pin Normally, fix to "L".
13	TST2	I	Test pin Normally, fix to "L".
14	TST3	I	Test pin Normally, fix to "L".
15	TST4	I	Test pin Normally, fix to "L".
16	XRST	I	System reset input L : reset.
17	BFOT	O	Clock and divided frequency output (384/768/256/512 fs)
18	CSL1	I	Test pin Normally, fix to "H".
19	CSL2	I	Test pin Normally, fix to "L".
20	VSS2	-	Digital ground
21	AVS3	-	Ground for L-ch D/A converter
22	AVD3	-	Power supply for L-ch D/A converter
23	LOUT	O	L-ch A/D converter output
24	AVD1	-	Power supply for L-ch A/D converter
25	AVS1	-	Ground for L-ch A/D converter
26	LO1	O	OP amp. inverting output for LPF of L-ch A/D converter
27	LIN	I	Analog input of L-ch A/D converter
28	AVD5	-	Power supply for C-ch D/A converter
29	AVS5	-	Ground for C-ch D/A converter
30	XCOUT	O	C-ch D/A converter output
31	AVDX	-	Analog power supply for master clock
32	XTLO	O	Crystal oscillation circuit output

No.	Pin Name	I/O	Function
33	XTLI	I	Crystal oscillation circuit input
34	AVSX	–	Analog ground for master clock
35	XSOUT	O	S-ch D/A converter output
36	AVS6	–	Ground for S-ch D/A converter
37	AVD6	–	Power supply for S-ch D/A converter
38	RIN	I	Analog input of R-ch A/D converter
39	LO2	O	OP amp. inverting output for LPF of R-ch A/D converter
40	AVS2	–	Ground for R-ch A/D converter
41	AVD2	–	Power supply for R-ch A/D converter
42	ROUT	O	R-ch D/A converter output
43	AVD4	–	Power supply for R-ch D/A converter
44	AVS4	–	Ground for R-ch D/A converter
45	VSS3	–	Digital ground
46	SCK	I	Shift clock input of microprocessor interface
47	REDY	O	Transfer permission signal output of microprocessor interface L : Transfer prohibition
48	T.P	–	Monitor pin for test Normally, outputs "Hi-Z".
49	XLAT	I	Latch input of microprocessor interface
50	RVDT	I	Data input of microprocessor interface
51	XS24	I	24/32 bit slot selection of serial data L : 24 bit slot (It is effective at slave mode.)
52	VDD1	–	Digital power supply
53	VSS4	–	Digital ground
54	T.P	–	Monitor pin for test Normally, outputs "L".
55	SI	I	Serial data input of 1 sampling 2 channel
56	T.P	–	Input pin for test Normally, outputs "L".
57	BCK	I/O	Serial bit transfer clock of serial input/output data SI and SO
58	LRCK	I/O	Sampling frequency clock of serial input/output data SI and SO
59	VSS5	–	Digital ground
60	XMST	I	Master/slave mode switching input of BCK and LRCK L : master mode
61-63	T.P	O	Monitor pin for test Normally, outputs "L".
64	VSS6	–	Digital ground
65-72	T.P	O	Monitor pin for test Normally, outputs "L".
73	VDD2	–	Digital power supply
74	VSS7	–	Digital ground
75-80	T.P	O	Monitor pin for test Normally, outputs "L".

7.1.2 DISPLAY

■ AAV7053 (FRONT ASSY : V501)

• FL TUBE

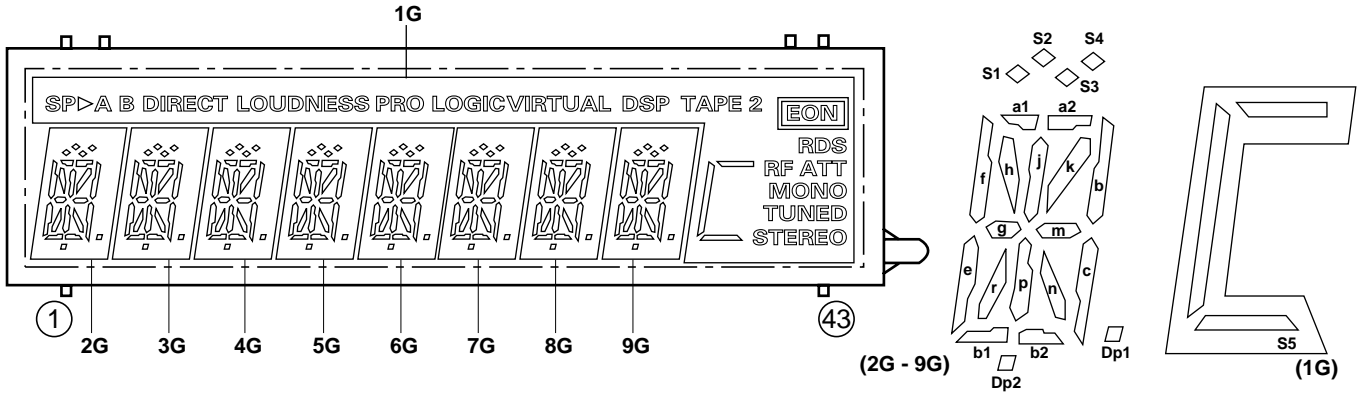

● ANODE AND GRID ASSIGNMENT

	1G	2G	3G	4G	5G	6G	7G	8G	9G
P1	SP>	a1	a1	a1	a1	a1	a1	a1	a1
P2	A	a2	a2	a2	a2	a2	a2	a2	a2
P3	B	h	h	h	h	h	h	h	h
P4	DIRECT	j	j	j	j	j	j	j	j
P5	LOUDNESS	k	k	k	k	k	k	k	k
P6	PRO LOGIC	b	b	b	b	b	b	b	b
P7	VIRTUAL	f	f	f	f	f	f	f	f
P8	DSP	m	m	m	m	m	m	m	m
P9	TAPE 2	g	g	g	g	g	g	g	g
P10	EON	c	c	c	c	c	c	c	c
P11	RDS	e	e	e	e	e	e	e	e
P12	S5	r	r	r	r	r	r	r	r
P13	RF ATT	p	p	p	p	p	p	p	p
P14	MONO	n	n	n	n	n	n	n	n
P15	TUNED	d1	d1	d1	d1	d1	d1	d1	d1
P16	STEREO	d2	d2	d2	d2	d2	d2	d2	d2
P17	—	Dp1	Dp1	Dp1	Dp1	Dp1	Dp1	Dp1	Dp1
P18	—	S1, S3	S1, S3	S1, S3	S1, S3	S1, S3	S1, S3	S1, S3	S1, S3
P19	—	S4	S4	S4	S4	S4	S4	S4	S4
P20	—	S2	S2	S2	S2	S2	S2	S2	S2
P21	—	Dp2	Dp2	Dp2	Dp2	Dp2	Dp2	Dp2	Dp2

● PIN ASSIGNMENT

Pin No.	1	2	3	4	5	6	7	8	9	10	11	12	13	14	15	16	17	18	19	20	21	22	23	24	25	26	27	28	29	30	31	32	33	34	35	36	37	38	39	40	41	42	43
Connection	F1	F1	NP	NP	1G	2G	3G	4G	5G	6G	7G	8G	9G	NX	NX	NX	NX	NX	P1	P2	P3	P4	P5	P6	P7	P8	P9	P10	P11	P12	P13	P14	P15	P16	P17	P18	P19	P20	P21	NP	NP	F2	F2

7.2 DISASSEMBLY

7.2.1 Bonnet and FRONT Assy

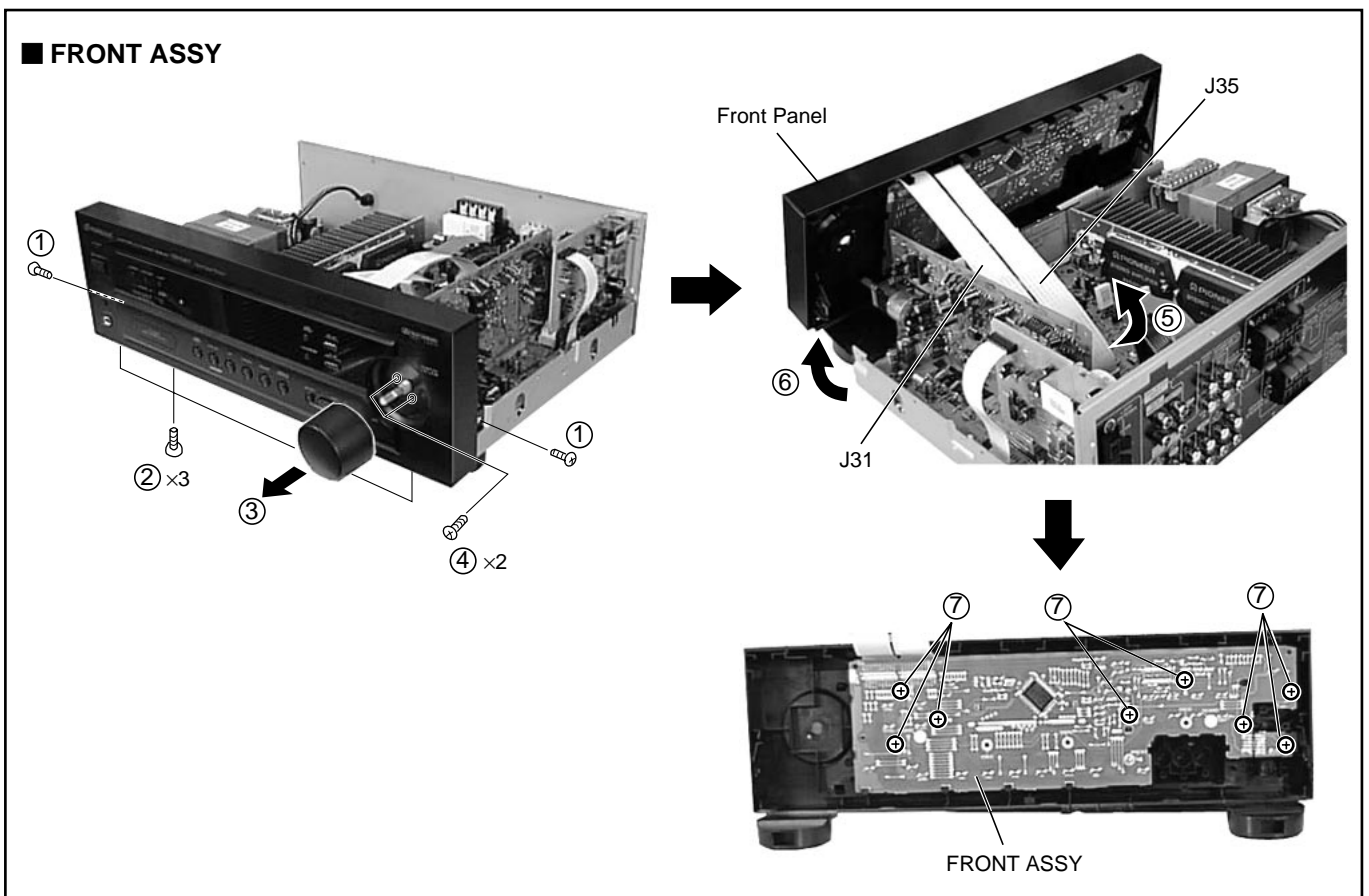
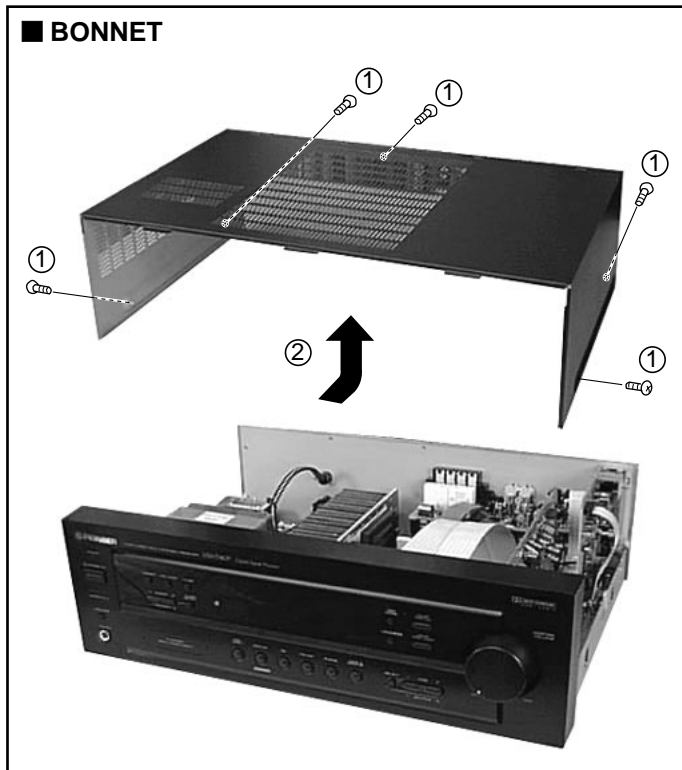

7.2.2 MOTHER and CONNECTION Assemblies

■ MOTHER AND CONNECTION ASSEMBLIES

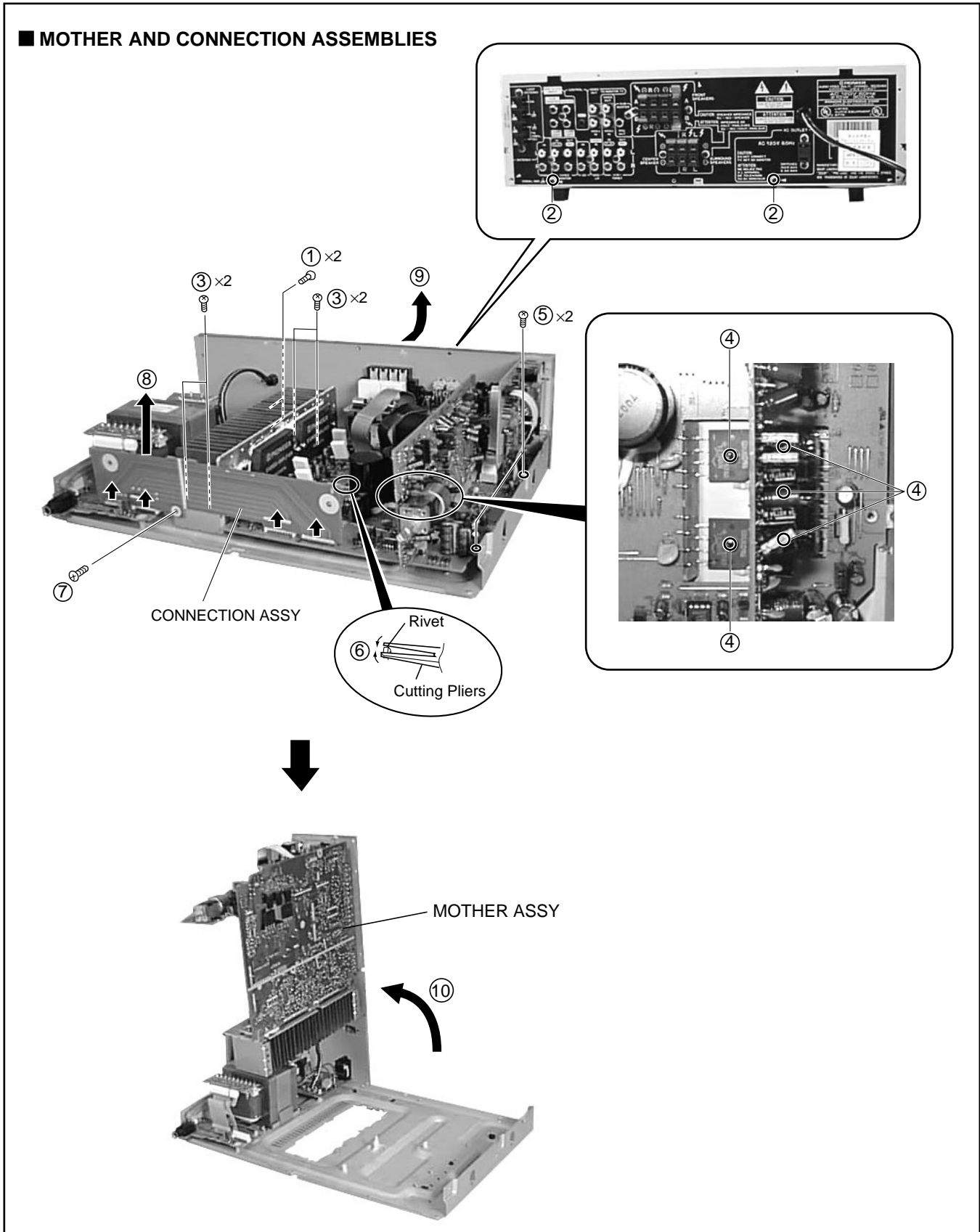

7.3 DIAGNOSIS

■ POWER PACK (MOTHER ASSY : IC401 and IC402) (At Bottom Side)

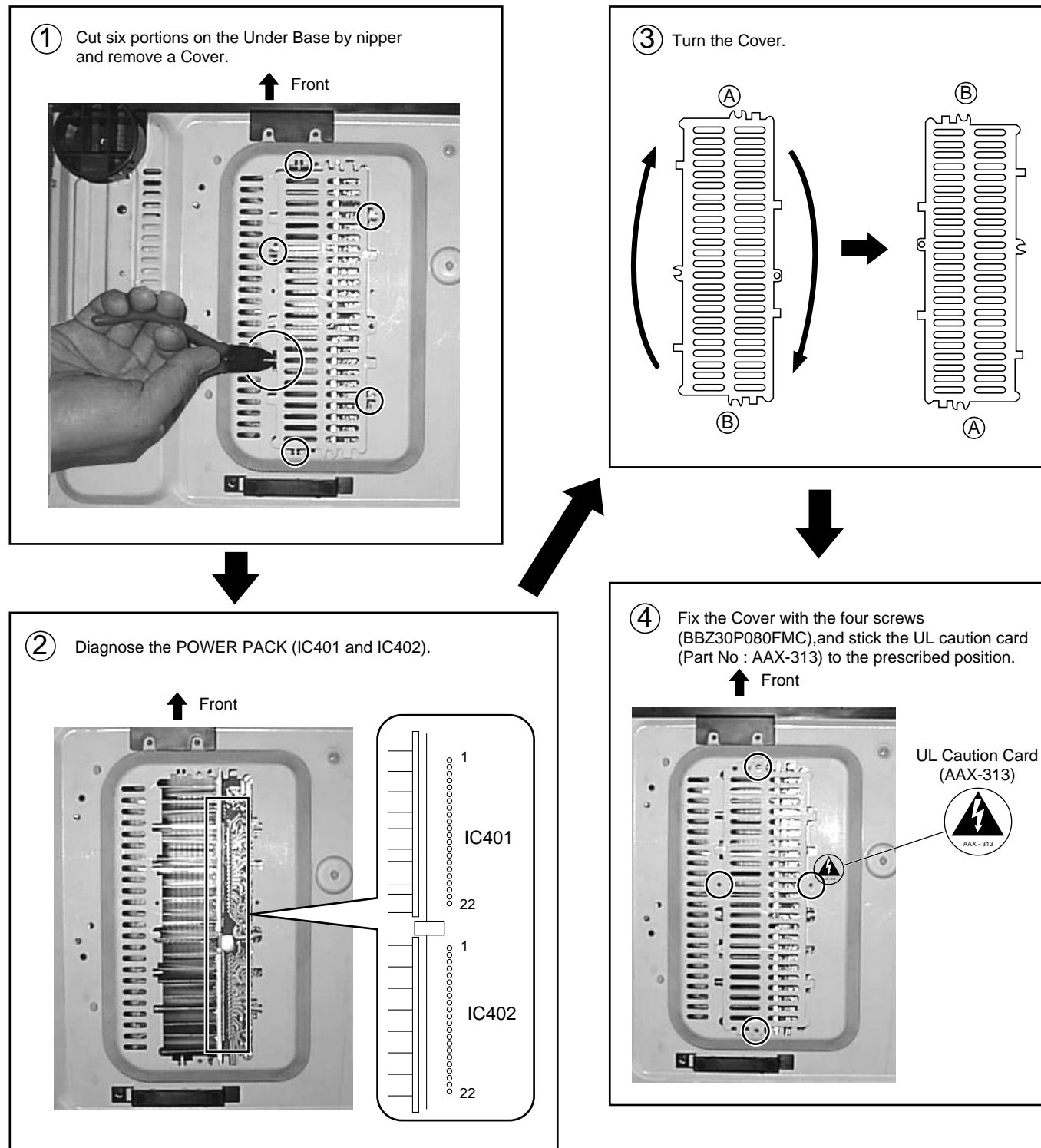

CAUTION :
 After performing the above operation, be sure to stick the UL caution card (Part No.: AAX-313) to the prescribed position.(It is required by the UL regulations.)
 After cutting the Under base and the Cover with a pair of nippers, be sure to smooth roughness from the edges to protect the user from a risk of damage caused by sharp edges.

7.4 BLOCK DIAGRAM

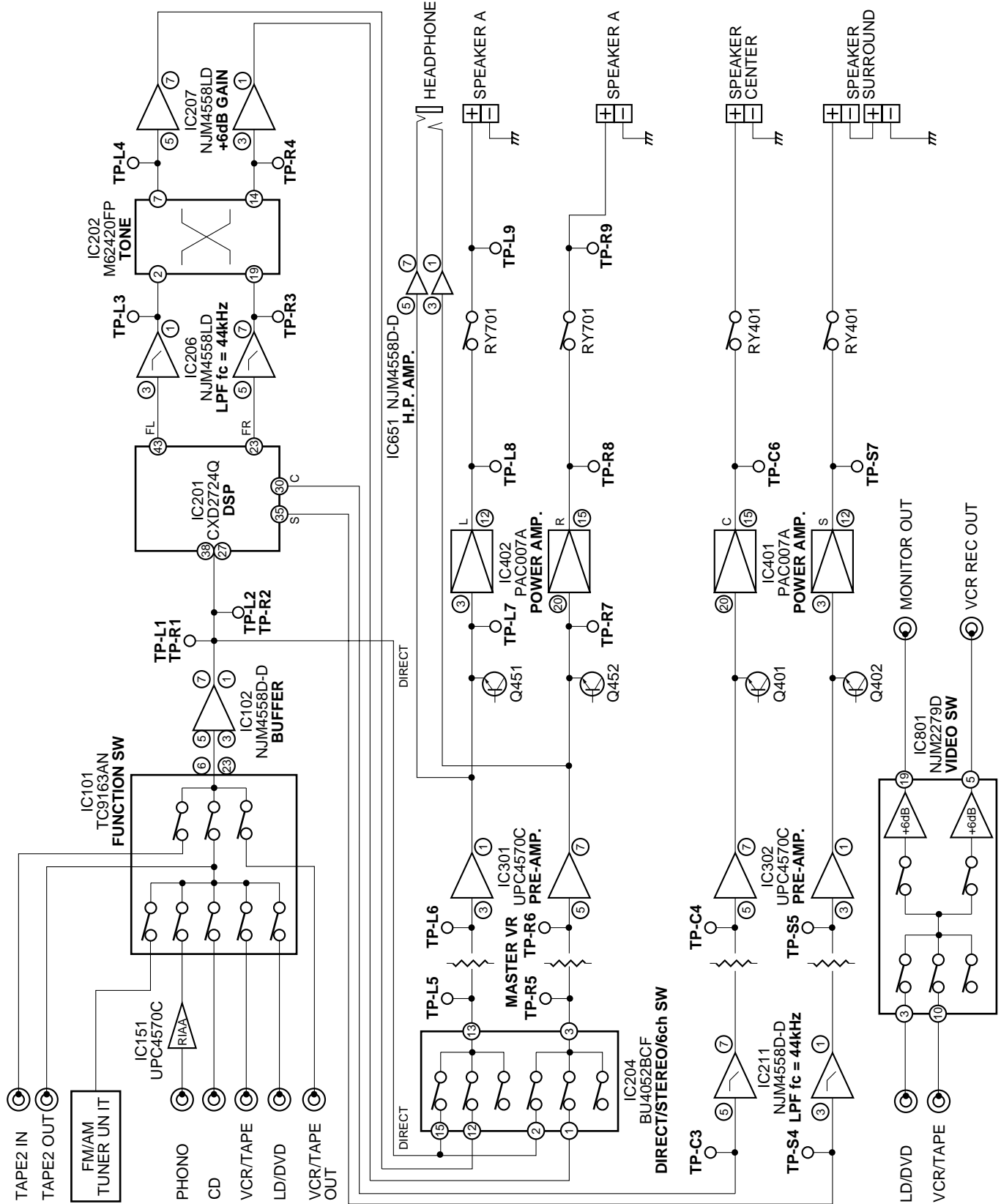

● Test Points for Diagnosis

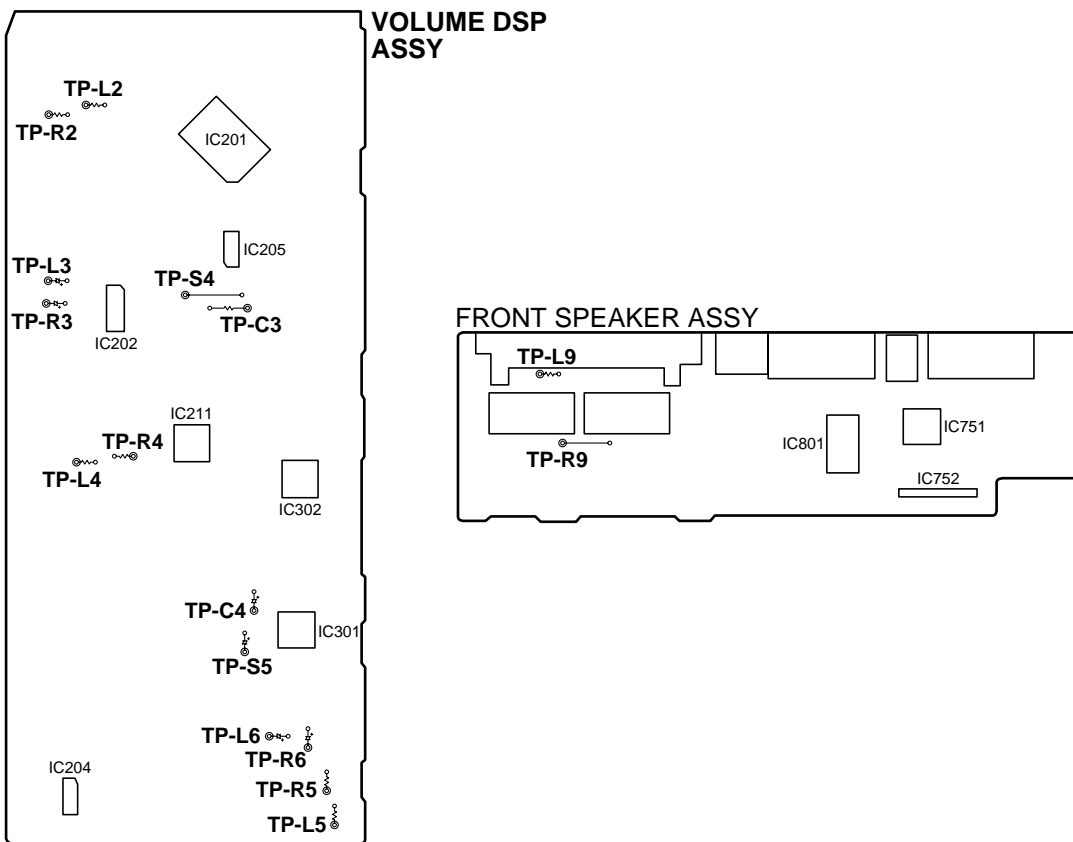
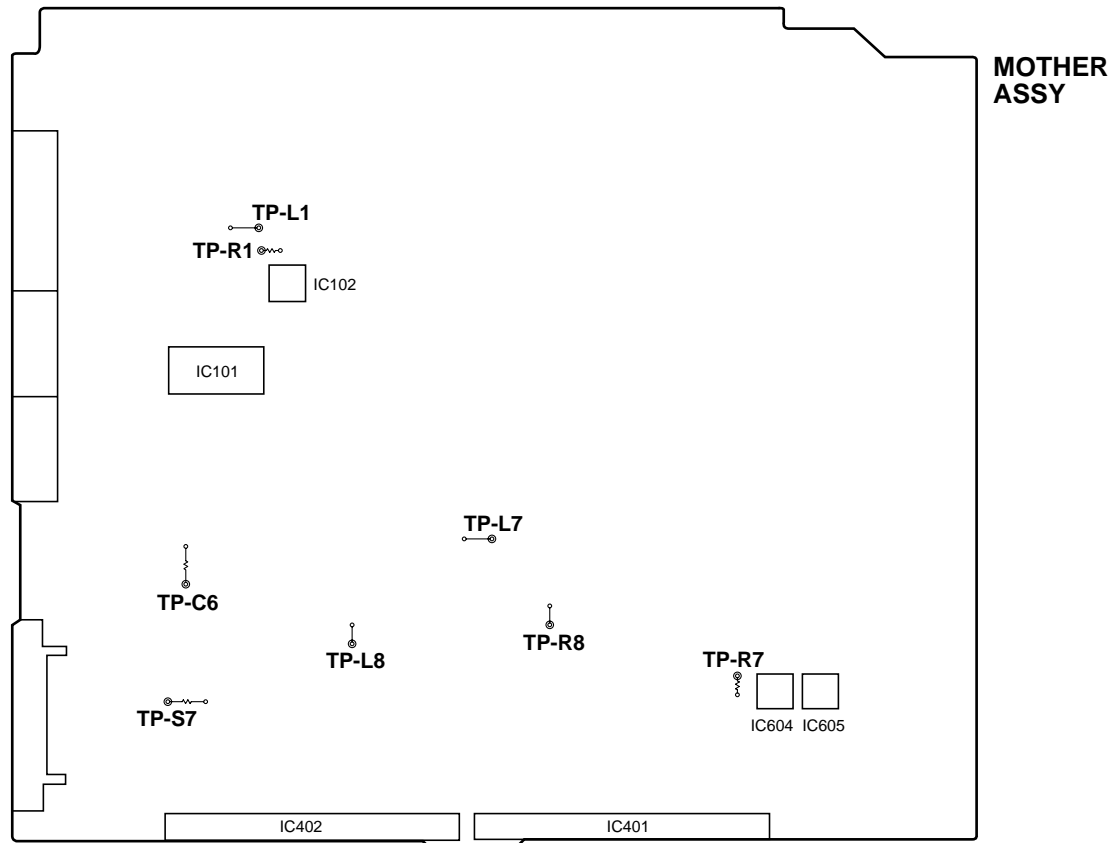

Fig.1 Test Point Location

8. PANEL FACILITIES AND SPECIFICATIONS

8.1 PANEL FACILITIES

Front Panel

The size of characters in the figure may differ from that on the actual product.

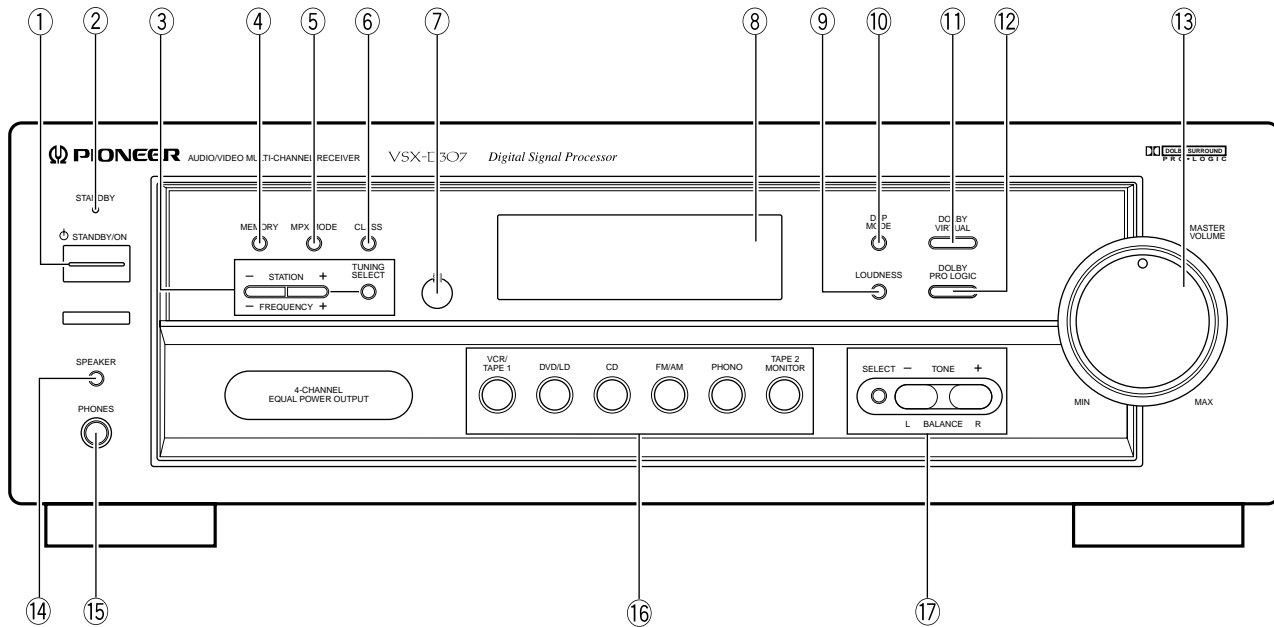

- ① **STANDBY/ON button**
- ② **STANDBY indicator**
- ③ **TUNING SELECT, STATION(-, +), FREQUENCY (-, +) button**

TUNING SELECT:

Use to select the STATION mode and FREQUENCY mode when operating the tuner.

STATION (-, +):

Use to select the station number when operating the tuner.

FREQUENCY (-, +):

Use to select the frequency when operating the tuner.

- ④ **MEMORY button**
 - ⑤ **MPX MODE button**
 - ⑥ **CLASS button**
 - ⑦ **Remote sensor**
 - ⑧ **Display**
 - ⑨ **LOUDNESS button**
- Use to switch the auto stereo/monaural mode for receiving FM broadcasts. When the received broadcast signal is weak, press this button to set the monaural mode.

- ⑩ **DSP MODE button**
- ⑪ **DOLBY VIRTUAL button**
- ⑫ **DOLBY PRO LOGIC button**
- ⑬ **MASTER VOLUME**
- ⑭ **SPEAKER button**

Switches as follows with each press.

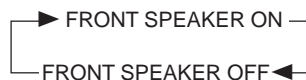

- ⑮ **PHONES jack (Headphone terminal)**
- ⑯ **Function buttons**
- ⑰ **SELECT, TONE (-, +) and BALANCE (L, R) button**

SELECT:

Use to select the TONE (TREBLE, BASS) and BALANCE control.

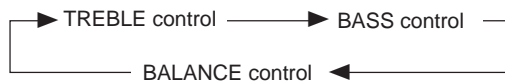

TONE (-, +):

Use to adjust tone.

BALANCE (L, R):

Use to adjust volume balance.

Display

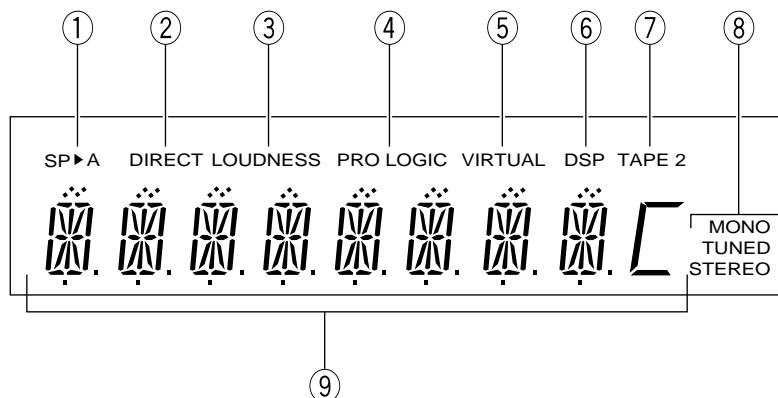

- ① **SPEAKER A indicator**
Lights when FRONT SPEAKER is ON.
- ② **DIRECT indicator**
Lights when DIRECT is ON.
- ③ **LOUDNESS indicator**
Lights when LOUDNESS is ON.
- ④ **PRO LOGIC indicator**
Lights when Dolby Pro Logic is selected.
- ⑤ **VIRTUAL indicator**
Lights when DOLBY VIRTUAL is selected.
- ⑥ **DSP indicator**
Lights when HALL, JAZZ, DANCE, THEATER 1 and THEATER 2 has been selected with the DSP MODE button.
- ⑦ **TAPE 2 indicator**
Lights when TAPE 2 MONITOR is ON.
- ⑧ **TUNER indicator**
MONO:
Lights when the monaural mode is set using the MPX MODE button.
TUNED:
Lights when broadcasts are being received.
STEREO:
Lights when stereo broadcasts are received during auto stereo mode.
- ⑨ **CHARACTER display**

CONNECTING DEVICES

When connecting or changing equipment, be sure to turn OFF the POWER switch, and disconnect the power cord from the wall outlet.

■ For better reception of signals, use the FM external antenna.

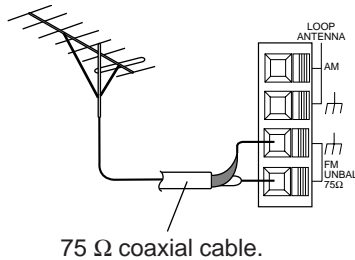

■ When AM broadcast reception is poor

Connect a 5 to 6 meter (15 to 18 feet) long vinyl-coated wire to the AM antenna. If possible draw horizontally outdoors to achieve better reception.

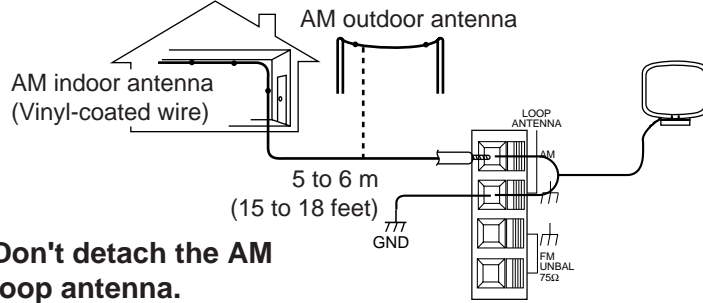

■ Assembling the AM loop antenna

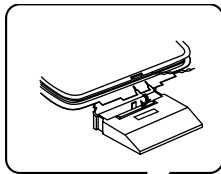

FM antenna

Stretch out fully and secure onto the wall using pins.

■ When attached on a wall, etc.

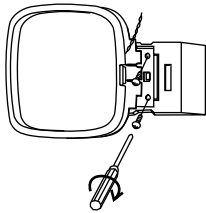

Face towards the direction with the best reception.

SIGNAL GND is used to decrease the noises when an analog player, etc. is connected. This is not a ground for safety.

* The sub woofer can be connected in a different way. For details, refer to the instructions on the sub woofer.

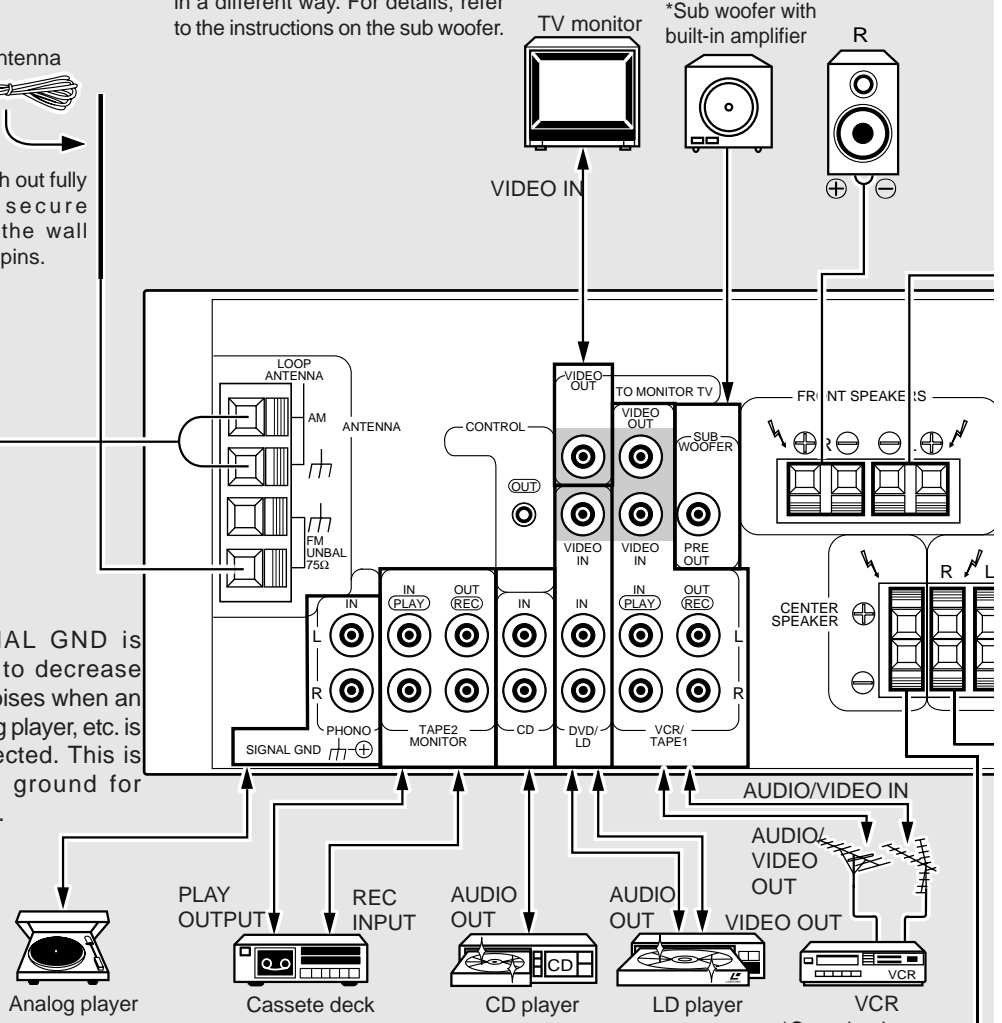

*Can also be connected to a DVD player.
*Can also be connected to a cassette deck.

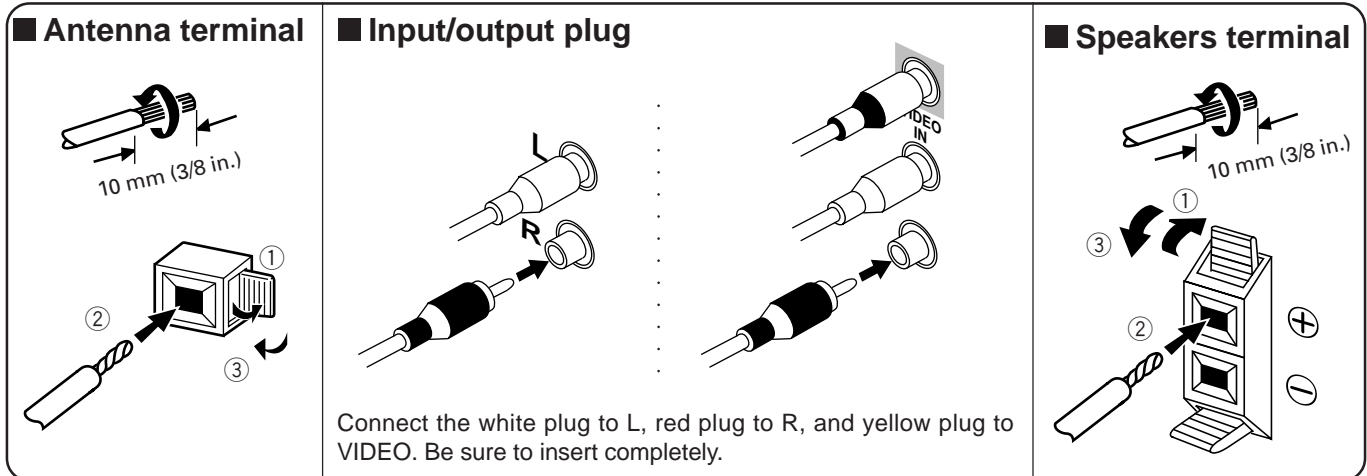

The size of characters and terminal positions in the figures may differ from those on the actual product.

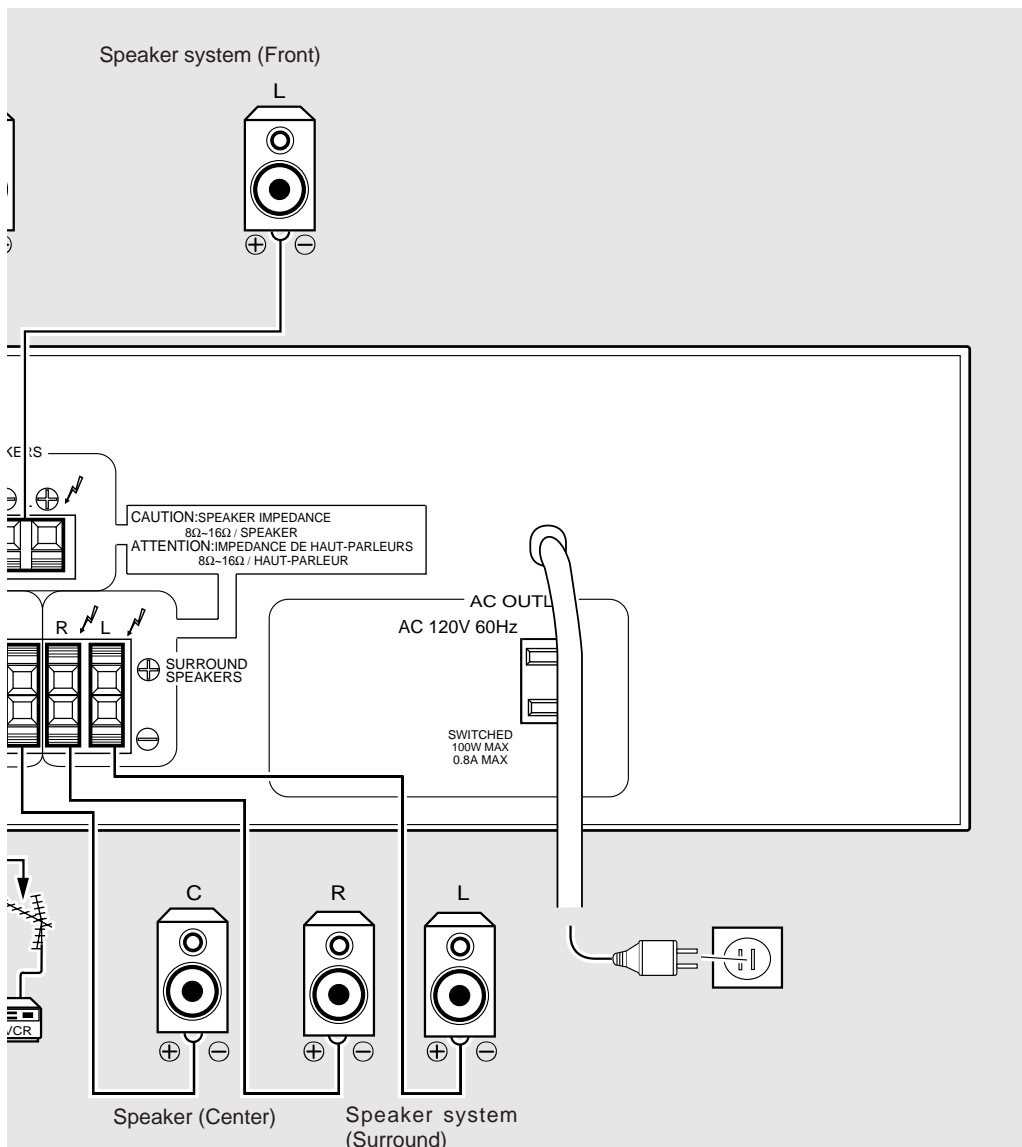

AC OUTLET [SWITCHED 100 W (0.8 A) MAX]

Power supplied through this outlet is turned on and off by the receiver's POWER switch.

Total electrical power consumption of connected equipment should not exceed 100 W (0.8 A).

Do not connect a heater, TV, etc.

REMOTE CONTROL UNIT

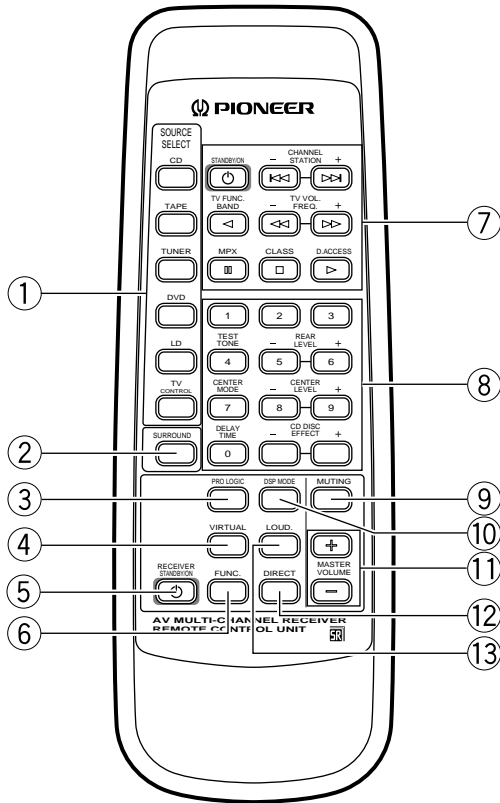

- ① **SOURCE SELECT function buttons**
When operating other devices, press any one of these buttons to specify the device to be operated.



This button cannot be used to switch the functions of this unit.

- ② **SURROUND button**
Press to start the SURROUND function.
- ③ **PRO LOGIC button**
Use to turn ON/OFF DOLBY PRO LOGIC.
- ④ **VIRTUAL button**
Use to change the mode of DOLBY VIRTUAL.
- ⑤ **RECEIVER STANDBY/ON button**
- ⑥ **FUNC. (FUNCTION) button**
Use to switch the function setting of this unit.

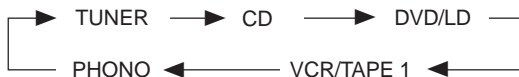

- ⑦ **[TUNER operations]**
STANDBY/ON, BAND, FREQ. -,+, MPX, CLASS, D.ACCESS buttons

- [TV operations]**
STANDBY/ON, CHANNEL -,+, TV FUNC., TV VOL. -,+, buttons

- [CD, TAPE, DVD, LD operations]**
STANDBY/ON, I<<<, >>>I (Chapter/Track search), ◀ (Play), ◀◀ (Rewind), ▶▶ (Fast Forward), || (Pause), ■ (Stop), ▶ (Play)

- ⑧ **Number/Surround setting buttons**
TEST TONE: When turned ON (while in DOLBY PRO LOGIC), volume balance adjustment signals are output in order from the speakers and can be adjusted.
REAR LEVEL -,+: Adjusts the rear level.
CENTER MODE: Switches the center mode.
CENTER LEVEL -,+: Adjusts the center level.
DELAY TIME: Use to set the delay time.
EFFECT -,+: Adjusts DSP effects.

- ⑨ **MUTING button**
Press to mute the volume.
- ⑩ **DSP MODE button**
Use to switch the DSP mode.
- ⑪ **MASTER VOLUME +/- button**
Use to adjust the volume.
- ⑫ **DIRECT button**
Use to playback sound without going through the tone and balance control circuits. DOLBY PRO LOGIC, DOLBY VIRTUAL, DSP MODE and LOUDNESS also turn off.
- ⑬ **LOUD.(LOUDNESS) button**
When LOUDNESS is turned ON at a small volume, the low frequency and high frequency levels increase, enabling the sound to be easier to hear.

8.2 SPECIFICATIONS

Amplifier section

Continuous average power output of 100 watts* per channel, min., at 8 ohms, from 40 Hz to 20,000 Hz with no more than 0.9% total harmonic distortion (front).**

Continuous Power Output

Front	100 W + 100 W (1kHz, 0.9 %, 8 Ω)
Center	100 W (1kHz, 0.9 %, 8 Ω)
Surround	100 W (1kHz, 0.9 %, 8 Ω)

Input (Sensitivity/Impedance)

PHONO MM	2.8 mV/47 kΩ
CD, VCR/TAPE 1, TAPE 2, DVD/LD	200 mV/47 kΩ

Phono Overload level (T.H.D. 0.1 %, 1kHz)

PHONO MM	100 mV
----------------	--------

Frequency Response

PHONO MM	20 Hz to 20,000 Hz ± 0.3 dB
CD, VCR/TAPE 1, TAPE 2, DVD/LD	5 Hz to 100,000 Hz ⁺⁰ ₋₃ dB

Output (Level/Impedance)

VCR/TAPE 1 REC, TAPE 2 REC	200 mV/2.2 kΩ
----------------------------------	---------------

Tone Control

BASS	± 8 dB (150 Hz)
TREBLE	± 8 dB (10 kHz)
LOUDNESS	+ 8 dB/+ 6 dB (100 Hz/10 kHz)

Signal-to-Noise Ratio (IHF, short circuited, A network)

PHONO MM	72 dB
CD, VCR/TAPE 1, TAPE 2, DVD/LD	96 dB

Signal-to Noise Ratio [EIA, at 1 W (1 kHz)]

PHONO MM	75 dB
CD, VCR/TAPE 1, TAPE 2, DVD/LD	79 dB

* Measured pursuant to the Federal Trade Commission's Trade Regulation rule on Power Output Claims for Amplifier.

** Measured by Audio Spectrum Analyzer.

VIDEO Section

Input (Sensitivity/Impedance)

VCR, DVD/LD	1 Vp-p/75 Ω
-------------------	-------------

Output (Level/Impedance)

VCR	1 Vp-p/75 Ω
-----------	-------------

Frequency Response

VCR, DVD/LD → MONITOR	5 Hz to 7 MHz ⁺⁰ ₋₃ dB
-----------------------------	--

Signal-to-Noise Ratio

Cross Talk	55 dB
------------------	-------

Manufactured under license from Dolby Laboratories Licensing Corporation. "Dolby", "AC-3", "Pro Logic" and the double-D symbol are trademarks of Dolby Laboratories Licensing Corporation. Copyright 1992 Dolby Laboratories, Inc. All rights reserved.

FM Tuner Section

Frequency Range	87.5 MHz to 108 MHz
Usable Sensitivity	Mono:13.2 dBf, IHF (1.3 μV/75 Ω)
50 dB Quieting Sensitivity	Mono: 20.2 dBf
	Stereo: 38.6 dBf
Signal-to-Noise Ratio	Mono: 73 dB (at 85 dBf)
	Stereo: 70 dB (at 85 dBf)
Distortion	Stereo: 0.5 % (1 kHz)
Alternate Channel Selectivity	60 dB (400 kHz)
Stereo Separation	40 dB (1 kHz)
Frequency Response	30 Hz to 15 kHz (±1) dB
Antenna Input	75 Ω unbalanced

AM Tuner Section

Frequency Range	530 kHz to 1,700 kHz
Sensitivity (IHF, Loop antenna)	350 μV/m
Selectivity	25 dB
Signal-to-Noise Ratio	50 dB
Antenna	Loop antenna

Miscellaneous

Power Requirements	AC 120 V, 60 Hz
Power Consumption	210 W
In Standby Condition	5 W
AC Outlet	
SWITCHED	100 W (0.8 A) MAX
Dimensions	420 (W) × 143 (H) × 325 (D) mm
	16-9/16 (W) × 5-5/8 (H) × 12-13/16 (D) in
Weight (without package)	7.4 kg (16 lb 5 oz)

Furnished Parts

FM Antenna	1
AM Loop Antenna	1
Dry Cell Batteries	
[size "AA" (IEC R6P)]	2
Remote Control Unit	1
Operating Instructions	1

● The remote control unit and dry cell battery are not provided with VSX-D307-HT.

NOTE:

Specifications and the design are subject to possible modifications without notice, due to improvements.

MAINTENANCE OF EXTERNAL SURFACES

- Use a polishing cloth or dry cloth to wipe off dust and dirt.
- When the surfaces are very dirty, wipe with a soft cloth dipped in some neutral cleanser diluted five or six times with water, and wrung out well, and then wipe again with a dry cloth. Do not use furniture wax or cleaners.
- Never use thinners, benzene, insecticide sprays or other chemicals on or near this unit, since these will corrode surfaces.

SPECIFICATIONS

Audio Amplifier Section

Continuous power output, 0.9% THD,
2 channels driven, 8 Ω load 40 Hz : More than 90 W
1 kHz : More than 90 W
20 kHz : More than 90 W
Gain, 8 Ω load Phono : 80.0 \pm 3 dB
CD : 42.0 \pm 3 dB
Noise output, 1 k Ω -terminated input,
VR at maximum Phono : Less than 60 mV
CD : Less than 40 mV
Residual noise, VR at minimum Less than 3 mV
Channel separation, 10 kHz Phono : More than 35 dB
CD : More than 35 dB
RIAA equalizer response,
at TAPE 1 REC OUT 100 Hz : RIAA \pm 2 dB
10 kHz : RIAA \pm 2 dB
Frequency response, CD input,
output at SP-A/8 Ω load 20 kHz : -2.0 \pm 5 dB
Tone control response, 100 Hz Maximum : +8 \pm 4 dB
Center : 0 \pm 3 dB
Minimum : -8 \pm 4 dB
Tone control response, 10 kHz Maximum : +8 \pm 4 dB
Center : 0 \pm 3 dB
Minimum : -8 \pm 4 dB

FM Tuner Section

(Unbalanced 75 Ω , at TAPE 1 REC-OUT)

Frequency Range 87.5 MHz to 108 MHz
IHF usable sensitivity 90 MHz : Less than 17 dB μ V
98 MHz : Less than 17 dB μ V
106 MHz : Less than 17 dB μ V
Output level, 60 dB μ V input Within -3.7 dBV \pm 7 dB
Signal to noise ratio, 60 dB μ V input More than 54 dB
Distortion, 60 dB μ V input Less than 4%
De-emphasis, deviation from 75 μ s
100 Hz/10kHz : Within 0 \pm 3 dB
Image interference ratio 98 MHz : More than 19 dB

FM MPX Section

(Unbalanced 75 Ω , at TAPE 1 REC-OUT)

Output level, 60 dB μ V input Within -4.5 dBV \pm 5 dB
Distortion, 60 dB μ V input Less than 4%
Stereo separation, 60 dB μ V input 100 Hz : More than 17 dB
1 kHz : More than 18 dB
10 kHz : More than 15 dB

AM Tuner Section

(Using AM loop antenna , at TAPE 1 REC-OUT)

Frequency Range 530 kHz to 1700 kHz
Usable sensitivity, at 30 dB S/N
600 kHz : Less than 84 dB μ V/m
1000 kHz : Less than 78 dB μ V/m
1400 kHz : Less than 78 dB μ V/m
Output level, 100 dB μ V/m input Within -16.5 dBV \pm 8 dB
Signal to noise ratio, 100 dB μ V/m input More than 35 dB
Distortion, 100 dB μ V/m input Less than 5%
Image interference ratio 1000 kHz : More than 15 dB
Tuning indicator sensitivity Less than 78 dB μ V/m
Selectivity, 74 dB μ V/m input More than 14 dB

Video Section

(DVD/LD input, at monitor terminal)

Video output level, color bar Within 1 V_{p-p} \pm 0.3 V
Video S/N, 100% white More than 45 dB

Surround Section

Output power, 0.8% THD, 8 Ω load Front : More than 90 W
Center : More than 90 W
Rear : More than 90 W
Residual noise, with 30 kHz LPF used Center : Less than 6 mV
Rear : Less than 6 mV

RadioShack
A Division of Tandy Corporation
Fort Worth, Texas 76102

RRV1949M ZZE