

INSTALLATION GUIDE



SCS-1R SECURITY CONTROL RECEIVER

DMP Receiver Help Line

Technical Service
1-888-436-7832

International
1-417-831-9362

After hours receiver emergencies
1-417-831-2866

**Security Control Receiver
Model SCS-1R
Installation Guide**

INDUSTRY CANADA NOTICE

This Class A digital apparatus complies with Canadian ICES-003.

© 2009 Digital Monitoring Products, Inc.

Information furnished by DMP is believed to be accurate and reliable.
This information is subject to change without notice.

Operator's Quick Reference	
Acknowledging an Alarm Signal	1
LED Indicators	1
System Overview	
Description	2
Function	2
32-Character LCD Membrane Keypad	2
Printer	2
Additional Messages	2
24-Hour Recall Tests	2
Line Capacity	2
Number of Standard/Encrypted Line Security Network Accounts	2
Opening and Closing Signals	2
System Block Diagram	3
Installation Checklist	
SCS-1R Faceplate	4
Earth Ground	4
Location of Circuit Boards	4
SCS-208 Power Cord.....	4
Phone Lines	4
Network Connection	4
AC Power.....	4
Optional Printer.....	4
Start up	4
Configuration	4
Model SCS-1R Security Control Receiver	
Description	5
SCS-1R Components Included	5
Model SCS-RACK System Enclosure	
Description	6
Modem Rack.....	6
Multibus Rack.....	6
32-Character LCD Membrane Keypad	6
Installing the SCS-RACK.....	6
Rack Mounting	6
Model SCS-150 Receiver Processor Board	
Description	7
Compatibility.....	7
Line Card Slots.....	7
Communication Output Ports.....	7
SCS-150 LEDs	7
Reset Button.....	7
Installing the SCS-150	7
Dip Switch Settings (S2)	7
Reset Programming To Factory Defaults	8
Clearing Receiver Events	8
Software Update Using the SD Card	8

TABLE OF CONTENTS

Model SCS-100 Line Card

Description	9
Transmit Level.....	9
Echo Cancel Off	9
Installing the SCS-100	9
Connecting the Phone Line	9
Phone Line Monitor.....	9
Power Monitor LED	9
SCS-100 LEDs	9

Model SCS-101 Network Interface Card

Description	10
Installing the SCS-101	10
Communication	10
LED Indicators	10
SCS-101 Data Jumper Settings	10
RXD and TXD.....	10
FORCE CTS.....	10

Model SCS-110 Modem Power Supply Card

Description	11
Installing the SCS-110	11
Power Monitor LEDs	11
LCD Membrane Keypad Trouble LED	11
UPS Trouble LED	11
AC Trouble LED	11

Model SCS-120 Multibus Power Supply Card

Description	12
Installing the SCS-120	12
Processor Monitor.....	12
Power Monitor LEDs	12

Model SCS-130 Transformer Card

Description	13
Installation.....	13
AC Power Connection	13
Three Amp Fuse.....	13

Model SCS-208 Power Cable

Description	14
Installation.....	14

Model SCS-203 Convenience Panel

Description	14
Installation.....	14

Model SCS-204 Host Cable

Description	14
Installation.....	14
Host Cable	14

SCS-1R Printer Cable

Printer Cable Pinout.....	15
---------------------------	----

Security Control Terms

Using the LCD Membrane Keypad

Special Keys.....	16
COMMAND Key	16
Back Arrow Key.....	16
Select Keys.....	16
Keypad Prompts Display Current Programming	16
Entering Alpha Characters.....	16

LCD Membrane Keypad Configuration

Internal Speaker Operation	17
LCD Backlighting	17
Display Options	17
Keypad Options and Diagnostics	17
Keypad Options.....	18
Accessing Keypad Diagnostics	18
Exiting the Installer Options.....	18

Status Displays and SCS-1R Programming

Receiver Startup Display	19
Time Display	19
Off-Normal Status.....	19
System Status	19
Programming Through Remote Link.....	20
Programming Menu	20
Service Code (XR500 Series panels).....	20
Receiver Options	20
Line Cards	21
Host Automation	22
Serial Ports	22
Set System Time/Date	23
Exit Programming Menu	23

Printout Explanations

General Description	24
System Messages	24
Command Processor Messages.....	24
Alarm, Trouble, and Restore	24
Ambush	24
Opening and Closing.....	24
Bypass and Reset	24
Schedule Changes	24
Door Access	25
Acknowledgment of Fire Alarms and Troubles.....	25
Message Destinations	25

Printer Troubleshooting

Activity Log ERROR	25
Power Light Not Lit.....	25
SEL Light Not Lit	25
PAPER Light Lit	25
Bad Printer Cable	25
Notes:	28

Components

Accessory Devices

Listings and Approvals

Operator's Quick Reference

This section explains basic operation for the operator.

Acknowledging an Alarm Signal

Press the key labeled ACK, or any top row Select key, to acknowledge an alarm.

When the SCS-1R is in normal mode, the alarm message displays in the LCD display.

If you are in programming when an alarm is received and requires acknowledgement, the ACK LED lights and the keypad begins to beep. If more than one message is received, the Message LED also lights.

You must exit programming before you can acknowledge any alarm signals. All alarms must be acknowledged before you can enter or return to programming mode.

LED Indicators

The SCS-1R features three LED indicators:

The Green Power LED lights when power is applied to the SCS-1R.

The Red ACK LED lights when an alarm signal is received that must be acknowledged.

The Red Message LED lights when more than one signal has been received that must be acknowledged.

System Overview

Description

The SCS-1R Security Control Receiver system from DMP is a full featured digital dialer and data network capable alarm receiver. The receiver provides a 32-character LCD display for viewing incoming messages and a built-in membrane keypad for acknowledging messages and configuring the SCS-1R system.

Function

The SCS-1R Receiver system provides central stations with computerized monitoring of DMP Command Processor™ panels. Features of the SCS-1R include automatic alarm, trouble, and supervisory account message logging on a local printer including the date and time of their occurrence. The SCS-1R also provides an output to most security automation software packages.

32-Character LCD Membrane Keypad

The built-in LCD display and Membrane Keypad add flexibility to the SCS-1R system by allowing the operator to view alarm messages before acknowledging them from the built-in Membrane Keypad. A typical alarm message includes the account number, zone name, and alarm type with the time and date of the occurrence. Alarm messages display on the LCD and print to the local printer.

Printer

Routine messages print without the need of operator response while non-routine messages print and display on the LCD for operator acknowledgment.

Note: UL central station applications must use a serial printer that is listed for Fire Protective Signaling Systems.

Additional Messages

Other messages transmitted to the SCS-1R by DMP Command Processor panels include:

- Zone bypasses and resets by name and number including the name of the person making the change
- Schedule changes including the name of the person making the change
- Trouble and Restoral message by zone name and number
- Door access reports including the user name and the number of the door being accessed

The Printout Explanation section of this guide provides a description of the SCS-1R alarm and activity messages that print and display.

24-Hour Recall Tests

The automatic recall test from a digital dialer account must be tracked manually or with a listed automation system. The SCS-1R Receiver does not automatically indicate a delinquent recall test. Failure to receive a signal from a Digital Alarm Communicator Panel (DACT) over a 24-hour period is handled by the automation system.

Line Capacity

The SCS-1R Receiver accommodates up to five incoming phone lines. The account range for Digital Dialer panels is 1 to 65,535.

To select the communication type used on each incoming line, refer to Line Card Programming section of this guide.

Number of Standard or Encrypted Line Security Network Accounts

The maximum number of accounts with standard or encrypted line security and substitution using 6 minute checkin that can be received by a single SCS-101 Line Card is 3200.

Opening and Closing Signals

The total capacity of opening or closing signals per SCS-1R Receiver, limited by automation system using 19200 baud and acknowledgement speed of 100 milliseconds, is 300 per minute.

System Block Diagram

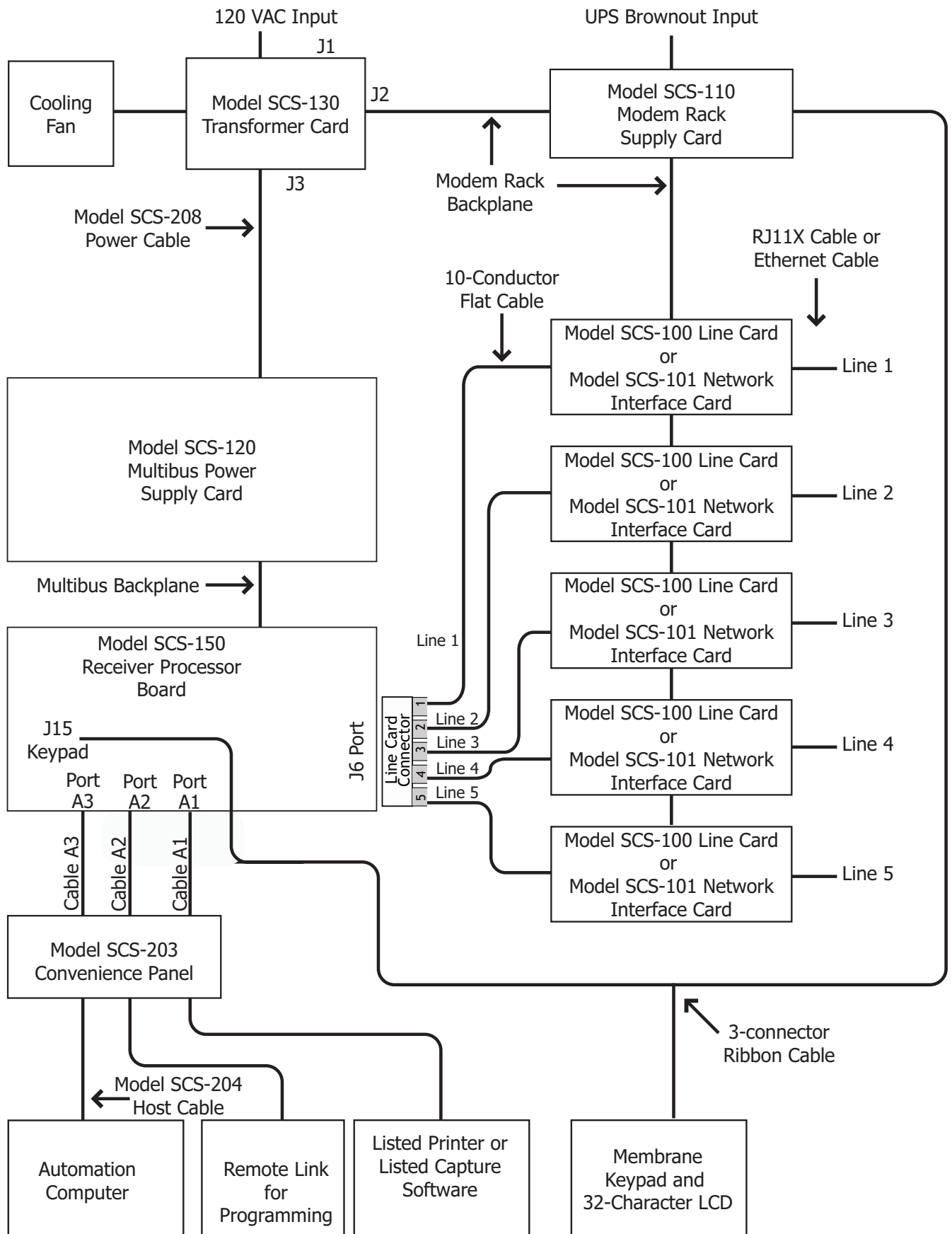

Installation Checklist

Refer to the Hardware Description section of this guide for installation, setup, and operating information.

SCS-1R Faceplate

To lower the SCS-1R faceplate, turn the two screws located in the top corners of the SCS-1R. The front of the SCS-1R opens on a hinge to allow access to the inside of the SCS-1R. Close the SCS-1R system by raising the front of the SCS-1R and securing the two screws in the top corners.

Earth Ground

Connect the ground lug on the modem rack rear side to earth ground. Using a minimum of 14 gauge wire, ground to a cold water pipe, building ground, or a ground rod. Do not ground to electrical conduit or telephone company ground.

Location of Circuit Boards

Confirm the circuit boards in the modem rack and in the multibus rack are installed properly and are in their proper locations. The circuit boards are properly installed when completely seated into the connector on the rack backplane.

SCS-208 Power Cord

Connect the SCS-208 Power Cord from the SCS-120 Multibus Power Supply card to the SCS-130 Transformer Card.

Phone Lines

Connect the RJ11X cables provided with each line card to the phone lines used for receiving alarms.

Network Connection

When using a network interface card, connect the SCS-101 network cable to the data network. Refer to the Hardware Description and Appendix for SCS-101 network installation instructions.

AC Power

AC power input of the receiver is 120 VAC, 60Hz and at least 3.5 Amps outlet not controlled by a switch . Do not apply AC power yet. For listed operation, use a listed uninterruptible power supply (UPS). The UPS system must have a secondary power source (batteries) and provide alarm contacts to indicate when the UPS switches from primary power to secondary power. The SCS-1R Receiver requires a UPS that delivers at least 400 VA power operating at 60Hz.

Optional Printer

Connect the RS-232 printer cable. Install paper, connect the printer to AC power, and turn on the printer power switch.

Note: UL central station applications must use a serial printer that is listed for Fire Protective Signaling Systems.

Start up

Apply 120 VAC to the AC power cord. The 120 volts supplied to the SCS-1R Receiver and the printer must be from the same UPS circuit.

Configuration

After powering up the system, set the correct time, configure the phone lines and network communications.

Note: Be sure that the Membrane Keypad is set to Address 01 (one). Refer to LCD Membrane Keypad Configuration for complete information.

Model SCS-1R Security Control Receiver

Description

The DMP SCS-1R Receiver ships from the factory with all of the necessary system components to provide two Digital Dialer lines and one line of Data Network receiving capability. This package can be expanded to include a maximum of five incoming communication lines. The SCS-101 Network Line Card allows you to connect a digital data network to the SCS-1R Receiver.

SCS-1R Components Included

The SCS-1R includes the following:

- SCS-RACK with Modem and Multibus Racks, fan, and 32-Character LCD with Membrane Keypad
- SCS-150 Receiver Processor Board
- SCS-100 Digital Dialer Line Card (Two included)
- SCS-101 Network Line Card
- SCS-110 Modem Supply Card
- SCS-120 Multibus Power Supply Card
- SCS-130 Transformer Card
- SCS-203 Convenience Panel
- SCS-208 Power Cord



Model SCS-RACK System Enclosure

Description

The SCS-RACK houses the receiver processor, power supply, line cards, and associated cables. The enclosure measures 8.75" high, 19" wide, and 12" deep.

Modem Rack

The SCS-RACK top portion holds the modem rack, which connects the SCS-110 Modem Power Supply Card and up to five line cards. The SCS-130 Transformer Card for connecting the 120 VAC mounts on the rear of the modem rack.

Multibus Rack

The bottom portion of the SCS-RACK holds the Multibus Rack, which holds the SCS-150 Receiver Processor Board and the SCS-120 Multibus Power Supply Card.

32-Character LCD Membrane Keypad

Mounted on the front faceplate of the SCS-RACK is a 32-character LCD Membrane Keypad. The LCD and keypad come pre-mounted and pre-wired with the power cable and ribbon cable.

Installing the SCS-RACK

Connect the SCS-RACK to earth ground before making any module connections. Use a minimum 14 gauge wire for grounding. A crimp type spade connector is provided for connecting the ground wire to the ground lug on the modem rack.

Rack Mounting

The SCS-1R must be mounted in a standard 19" rack for listed Fire Signaling applications. Simply slide the entire unit into the 19" rack and secure with screws. Refer to the drawing below for rack-mounting hole locations.

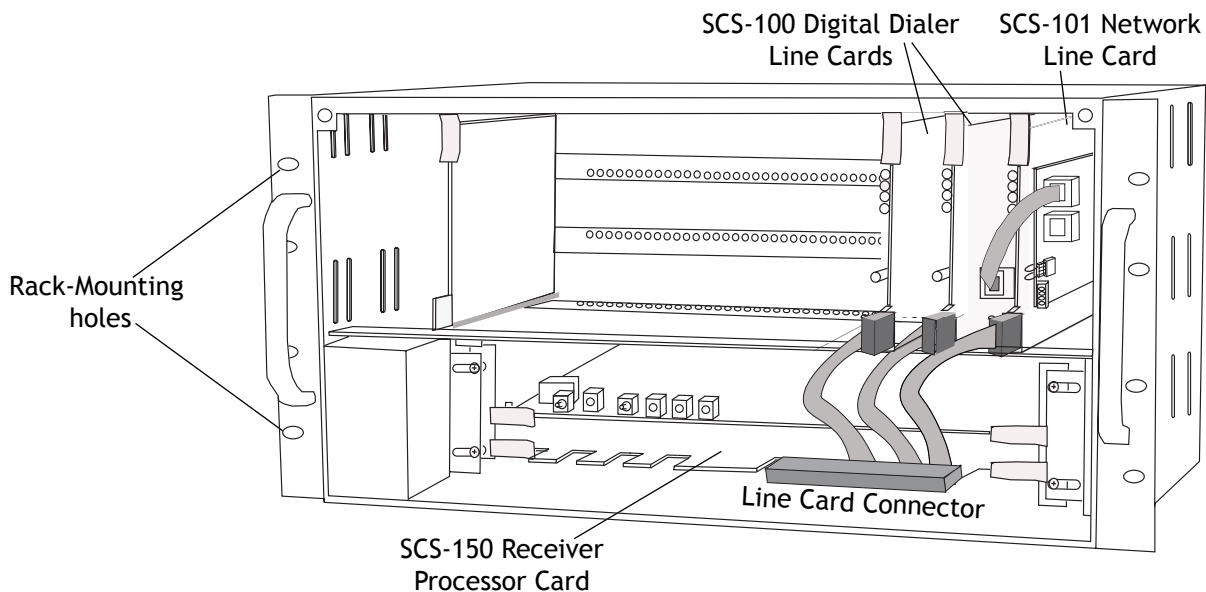

Model SCS-150 Receiver Processor Board

Description

The SCS-150 is the main system processor for the SCS-1R Security Control Receiver and controls the line cards, the LCD display, the printer (if used), and data output to a host automation system. The SCS-150 contains the software for system operation, the line configuration, and all time keeping functions. Programming can be done from the front panel of the SCS-1R Receiver or via Remote Link version 1.47 or higher.

Compatibility

The SCS-150 is compatible with the SCS-100 Dialer Line Cards and the SCS-101 Network Line Card using Level E hardware with Version 200 or higher software.

Line Card Slots

The SCS-150 Receiver Processor Board has a port (J6) for a line card connector and has five cables to support single dialer or ethernet cards. Slide the Line Card Cable Connector onto the J6 port on the SCS-150. Connect the line card cables to the existing line cards.

Communication Output Ports

The SCS-150 receiver has three ports to use for peripheral communication. The A1 port is used for printing to the Activity Log, the A2 port is for programming using Remote Link, and the A3 port is used as a host automation output port.

SCS-150 LEDs

- 1) Far Left LED: Flashes constantly. This is the heartbeat LED.
- 2) Center Left LED: On when the SCS-1R is saving data, such as programming changes.
- 3) Not used.
- 4) Far Right LED: On if memory resources are ever too low, such as thousands of messages pending at the LCD display or the printer.

Reset Button

The reset button resets the SCS-150 receiver but does not clear the stored events.

Installing the SCS-150



Always remove power to the SCS-1R Receiver when installing or removing any components.

- 1) Check that the S2 dip switch settings on the SCS-150 are set to OFF for Normal Operation.
- 2) Slide the center connector of the new keypad cable onto the keypad PCB. Connect the end labeled "J15" to the SCS-150 Keypad J15 header. Connect the other end to the SCS-110 Modem Power Supply card with Brown stripe to the top.
- 3) Slide the SCS-150 into the SCS-RACK lowest position, component side up. Press into place.
- 4) Install the SCS-203 cables labeled "A1" to port A1, "A2" to port A2, and "A3" to port A3 (Brown stripe to the right).
- 5) Slide the Line Card Cable Connector onto the J6 port on the SCS-150 (Brown stripe to the right). Connect the line card cables to the existing line cards making sure that the brown wire always faces up and the cable labeled 1 is to the right.
- 6) Once all connections are completed, power up the SCS-1R.

Dip Switch Settings (S2)

Dip switches 1-4, designated as S2 on the SCS-150 board, have the following settings and usage:

Settings: 0 is OFF, 1 is ON				Function	Description
1	2	3	4	Normal Operation	Used during normal receiver operation
0	0	0	0	Default Programming	Set the receiver programming stored in EEPROM to factory defaults
1	0	1	0	Update Software	Used for software updates with the SD card
1	1	0	1	Clear Events	Clear all pending LCD display, printer, and host output events

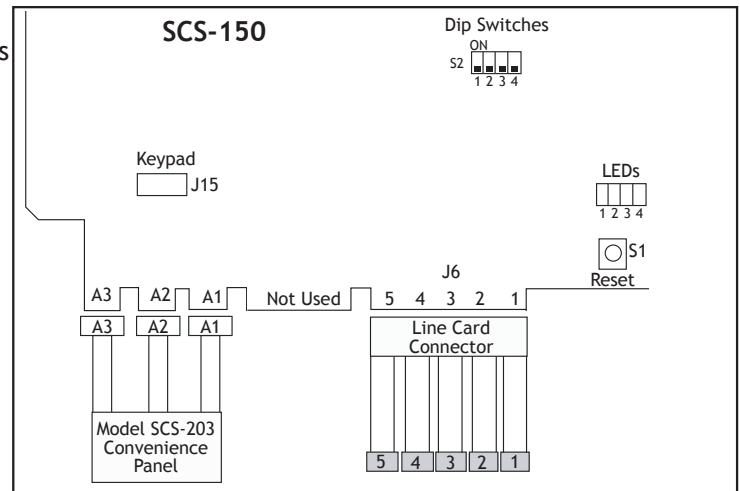
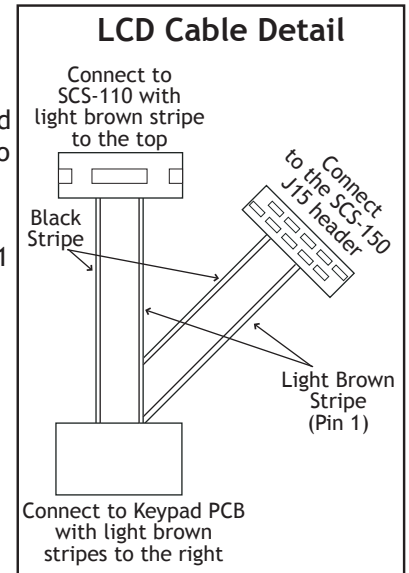



Before changing the the dip switch settings on the SCS-150 board, first power down the SCS-1R receiver and remove the processor board. After setting the dip switches, plug the SCS-150 board back into the receiver and power up.

Reset Programming To Factory Defaults

Return the receiver programming in EEPROM to factory defaults using the procedure below.

- Power down the SCS-1R and remove the SCS-150 board.
- Set the dip switches to 1010.
- Replace the SCS-150 board and power up.
- Wait until after the VERSION/DATE/CODE screen is displayed.
- Reset the dip switches to 0000 and replace the SCS-150 board.

Clearing Receiver Events

The SCS-150 stores up to 5000 events in battery-backed RAM.

Clear the receiver events stored in RAM using the procedure below.

- Set the dip switches to 1111.
- Replace the SCS-150 board and power up.
- Wait until after the VERSION/DATE/CODE screen is displayed.
- Reset the dip switches to 0000 and replace the SCS-150 board.

Software Update Using the SD Card

The SD (Secure Digital) card slot may be used for software updates.

Before updating, make sure the SD Card is formatted for FAT32.

- Insert the SD Card into the card reader attached to the computer.
- Go to My Computer and right-click on the drive that has the card reader attached.
- Select Properties to display the Removable Disk Properties.
- If the File System displays FAT32, then you are ready to load the software onto the SD Card.
- If the File System does not show FAT32 as the File System, the SD Card needs to be formatted.

To format the SD card:

- Go to My Computer and right-click on the drive that has the card reader attached.
- Select Format to open up the Format Removable Disk window.
- Select FAT32 in the File system drop-down menu and select *Start*.
- To format the disk, click *OK* on the pop-up Warning box.

To load the software onto the SD Card:

- Locate the software download on the Dealer Direct website. Click on title to download.
- Select Save in the popup window. Save the zip file to your computer.
- Extract the zip file onto the SD Card. There should be two files extracted on the SD card: SCS150a.bin and SCS150b.bin. **Note:** These two files need to be placed on the root directory of the SD card, not inside a folder.

To update the SCS-150:

- Set the S2 dip switches on the SCS-150 to 1101 (ON ON OFF ON).
- Insert a FAT32 formatted SD card with the new software into the SD card slot on the SCS-150 processor board.
- Reconnect the keypad to the J15 header.
- Insert the SCS-150 processor board into the SCS-1R and power up. Observe the display for programming status.
- When finished with the update the SCS-1R display instructs you to remove the SD Card.
- Remove the SD card from the SCS-150 and remove the SCS-150 board.
- Reset the dip switches to 0000 (OFF OFF OFF OFF) and replace the SCS-150 board and cables.

Model SCS-100 Line Card

Description

The SCS-100 provides for one incoming line of digital dialer (DD) communication to DMP Command Processor™ panels. Each line card includes one RJ11X cable for phone line connection from a customer supplied RJ11X connection block.

Transmit Level

The Transmit Level is the level of signal strength at which the SCS-100 transmits through the phone line. To adjust the transmit level, place the 2-pin jumper on the desired level on the J11 Transmit Level header.

The Transmit Level comes from the factory set to -9 dB. -9 dB is the quietest, 0 dB is the loudest.

Echo Cancel Off

Echo Cancellation is technology used by telephone companies to stop echo from interfering with digital telephone transmissions. In some cases this technology can interfere with alarm signals. If you have problems with Echo Cancellation interfering with your signals, place the 2-pin jumper on the J12 Echo Cancel Off header to the YES position to turn off the echo cancellers. If you are not having problems with the telephone company echo cancellation, leave the jumper on the default setting of NO to leave the echo cancelers on.

Installing the SCS-100



Install the SCS-100 in any one of the SCS-RACK five right hand positions with the card puller in the up position. Connect the 10-position flat cable from the SCS-150 processor card. The line card line number is determined by the processor card cable it is connected to.

THE LIGHT BROWN (PIN 1) WIRE OF THE FLAT CABLE CONNECTOR MUST FACE UP ON THE LINE CARD.

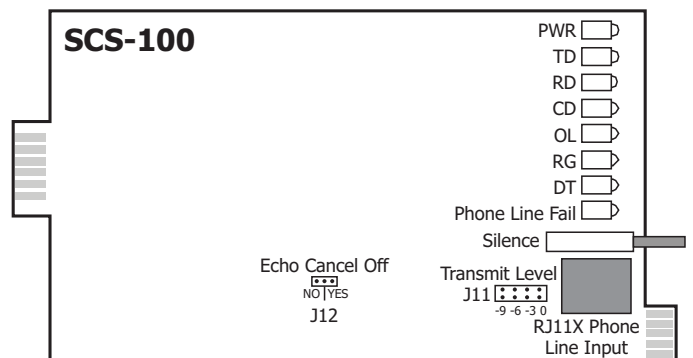
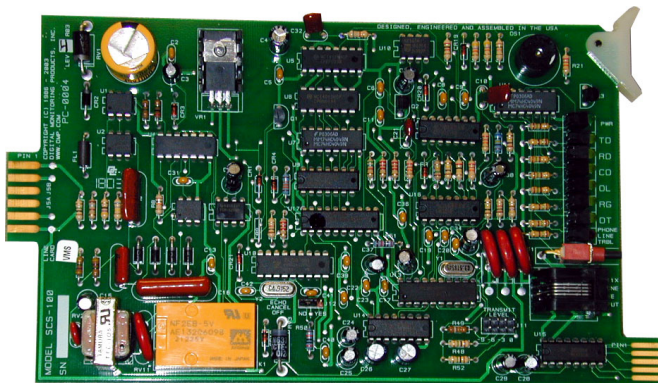

Connecting the Phone Line

Install the RJ11X cable provided with the line card between the RJ11X connector on the line card front to a customer supplied RJ jack. Use a standard 103J voice grade (analog) line. A slot is provided in the receiver back plate for the RJ11X cable to pass through. Maximum line impedance is 100 Ohms.

The SCS-100 is registered with the FCC, registration number CCK8GW-16197-AL-N; Ringer Equivalence 1.2.

Phone Line Monitor

The SCS-100 monitors the incoming phone line voltage. During a loss of phone line voltage, the red Phone Line Fail LED lights and the alert sounds. The alert can be silenced by pressing the silence switch on the SCS-100. The LED remains lit until the phone line is restored.

Power Monitor LED

The green LED labeled PWR lights when the power supply on the line card is working properly.

SCS-100 LEDs

The six yellow LEDs indicate the line card condition during the various stages of communication. A description of each LED is listed below:

TD	Transmit Data	On when the line card is transmitting to a panel.
RD	Receive Data	On when the line card is receiving data from a panel.
CD	Carrier Detect	On when the carrier tone from the panel is detected on the phone line.
OL	On Line	On when a digital dialer line card has answered the phone line.
RG	Ring Detect	On when ringing voltage is detected on phone line.
DT	Data Terminal Ready	On when the line card is ready for operation.

Model SCS-101 Network Interface Card

Description

The SCS-101 Network Interface Card provides for a connection from a digital data network to a port on the SCS-1R Receiver. Each card includes one eight-pin modular connector for digital data network connection. This allows the SCS-1R Receiver to accept alarm and system messages over a network from DMP Command Processor panels. Refer to the SCS-101 Installation Guide (LT-0320).

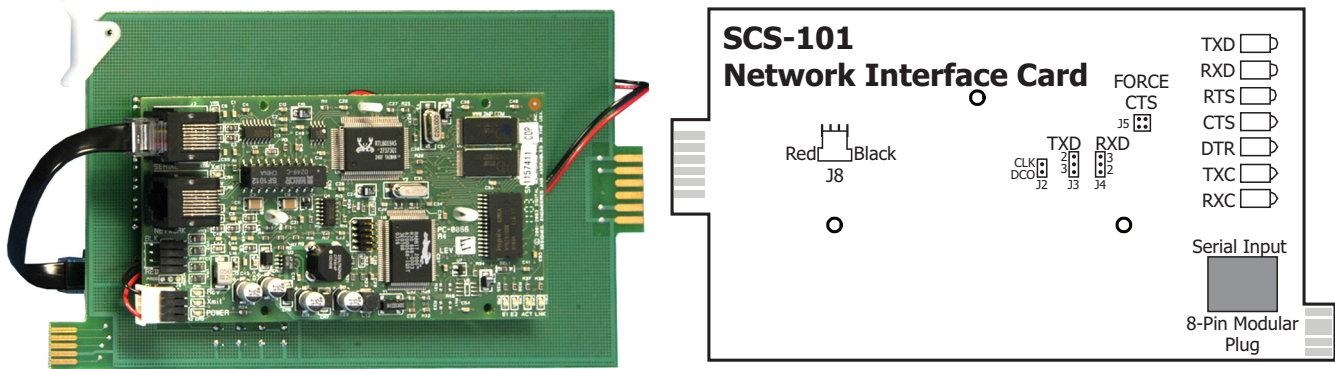

Installing the SCS-101

Slide the SCS-101 into the desired modem rack line card slot with the card puller in the up position, as shown in the figure above. Connect the 10-position flat cable from the SCS-150. The light brown (pin 1) wire of the flat cable connector must face up on the line card. Connect the IP network cable. Maximum line impedance is 100 Ohms.

For ULC Medium to Very High Risk Commercial Burglar Applications

The SCS-101 Network Line Card installed in the SCS-1R Receiver must have the ACK Substitution Message programmed as NO.

Communication

The SCS-101 automatically communicates UDP or TCP with DMP panels, iCOM-E™ Encrypted Network Alarm Routers, iCOM™ Network Alarm Routers, and iCOMSL Network Alarm Communicators.

LED Indicators

The seven bi-color LEDs indicate the network interface card condition during various stages of communication. A description of each LED is listed below:

TXD	Transmit Data	RXD	Receive Data
RTS	Ready To Send	CTS	Clear To Send
DTR	Data Terminal Ready	TXC	*Transmit Clock
RXC	*Receive Clock		

* If the clock signal is present, both red and green segments of the LEDs light.

SCS-101 Data Jumper Settings

The SCS-101 data jumpers are pre-configured for NET at the factory.

RXD and TXD

The factory setting is Transmit Data (TXD) on pin #2 and Receive Data (RXD) on pin #3.

FORCE CTS

The jumpers are set vertically as the factory default. This allows the SCS-101 to tie the CTS and RTS data lines together.

Model SCS-110 Modem Power Supply Card

Description

The SCS-110 provides power to a maximum of five line cards. Power is supplied through the modem rack backplane connectors without additional cabling. The SCS-110 also provides LCD and keypad connection, UPS system status, and the 120 VAC input monitoring information to the SCS-1R Receiver.

Installing the SCS-110



Always remove power to the SCS-1R Receiver when installing or removing the SCS-110.

Slide the SCS-110 into the modem rack far left hand position, with the card puller up as shown below. Plug the flat cable from the membrane keypad PCB onto the card edge connector at the bottom of the SCS-110. The light brown (pin 1) wire of the flat cable connector must face up on the power supply card.

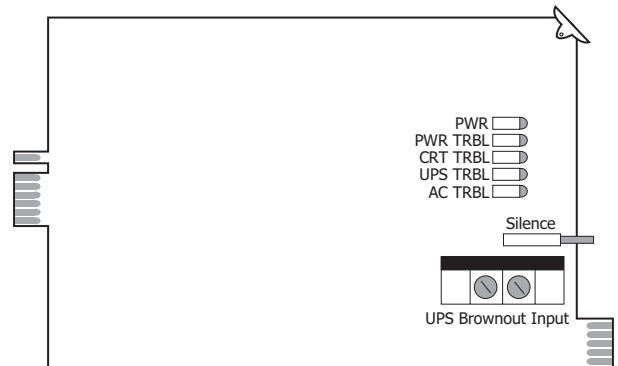
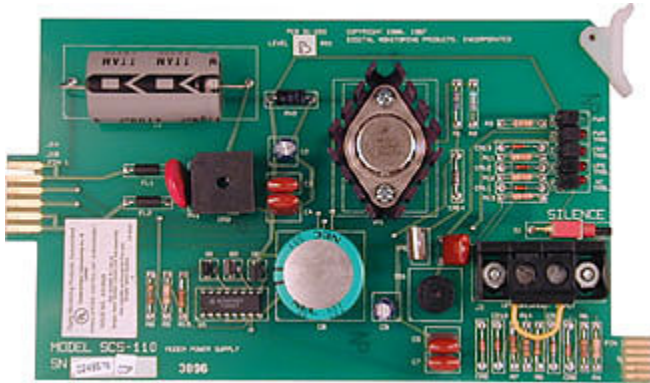

Power Monitor LEDs

The green LED labeled PWR lights when the power supply to the SCS-110 is working properly. The red LED labeled PWR TRBL is controlled by the SCS-120 Multibus Power Supply Card and lights when there is a power problem on the SCS-110. The red LED remains lit until the power problem is corrected. The alert tone on the SCS-110 Modem Power Supply Card sounds during a power problem and is silenced by pressing the silence switch on the SCS-110.

LCD Membrane Keypad Trouble LED

The LCD Membrane Keypad trouble LED lights and the alert tone sounds when the LCD Membrane Keypad fails to operate or the cable is unplugged. The alert tone is silenced by pressing the silence button on the SCS-110.

UPS Trouble LED

The UPS (Uninterrupted Power Supply) trouble LED lights and the alert tone sounds when the UPS Brownout Input is opened. Connect this circuit to the brownout contacts on your UPS system (Refer to SCS-130 information). No End-of-Line resistor is needed. Silence the alert tone by pressing the silence button on the SCS-110.

AC Trouble LED

The AC trouble LED lights and the alert tone sounds when AC power to the SCS-130 Transformer Card fails. Silence the alert tone by pressing the silence button on the SCS-110.

Model SCS-120 Multibus Power Supply Card

Description

The SCS-120 provides power to the SCS-150 through the multibus backplane. The SCS-120 also monitors the SCS-150 condition, the SCS-110 Modem Power Supply Card voltage output, and its own internal voltages.

Installing the SCS-120



Always disconnect power to the SCS-1R Receiver when installing or removing the SCS-120. Slide the SCS-120 Multibus Power Supply Card, the component side up, into the multibus rack upper position, which is the lower rack in the SCS-RACK.

Connect the SCS-208 Power Cable to J3 on the card front right side. Connect the other end of the power cable to the SCS-130 Transformer Card on the back of the modem rack. The power cable can be used in either direction.

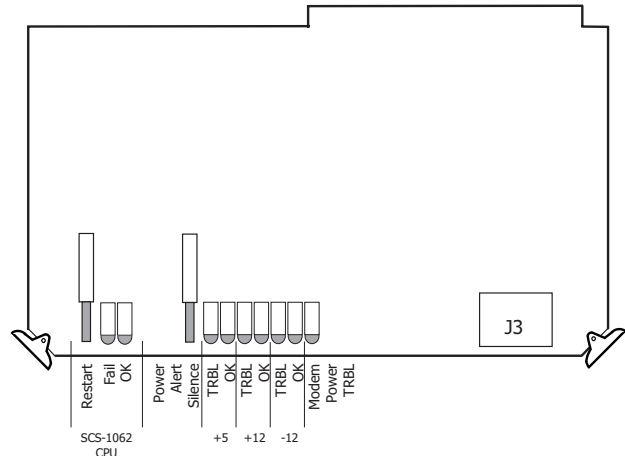
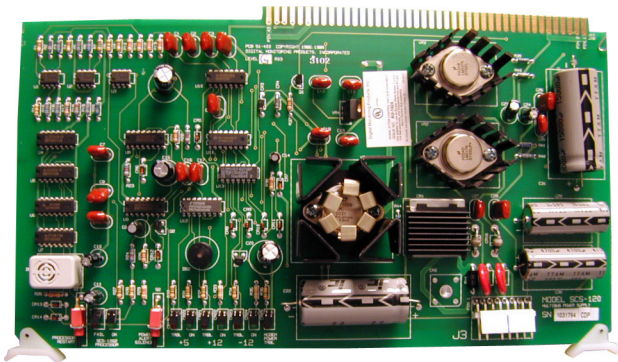

Processor Monitor

The SCS-120 monitors the Model SCS-150 processor through the multibus backplane. The green OK LED lights when the processor operates. If the processor stops operating, the red FAIL LED lights and the SCS-120 failure buzzer sounds.

Press the processor restart button to restart the system, silence the buzzer, and turn off the red LED. The restart button restarts the system.

Power Monitor LEDs

The SCS-120 monitors three different system voltages, +5, +12, -12 and the modem power supply. Four LEDs located to the right of the power alert silence switch display any voltage failures. A green OK LED lights when the voltages are working properly. The green PWR LED for the modem power supply is located on the SCS-110 Modem Power Supply Card. The red TRBL LED lights and the trouble alert tone on the SCS-120 sounds when there is a problem with a voltage level.

Press the SCS-120 power alert silence switch to silence the alert tone. The red TRBL LED remains lit until the power problem is corrected. The modem power LED, the SCS-120 trouble alert tone, and the SCS-110 Modem Power Supply Card power alert LED all operate together.

Model SCS-130 Transformer Card

Description

The SCS-130 provides power to the SCS-110 Modem Power Supply Card and the SCS-120 Multibus Power Supply Card. Two terminals are provided for connecting 120 VAC to the system. A power cord is provided for connecting the multibus rack cooling fan.

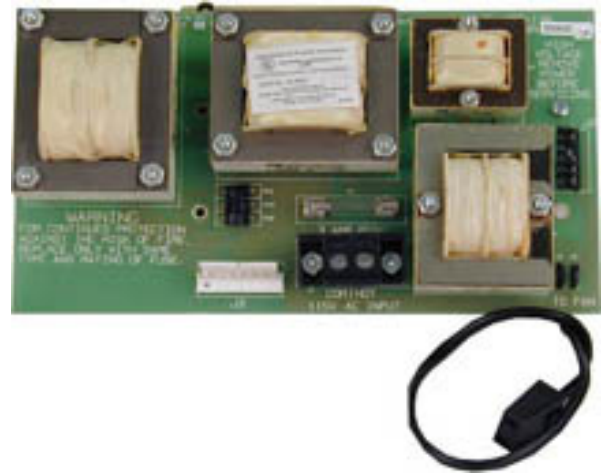
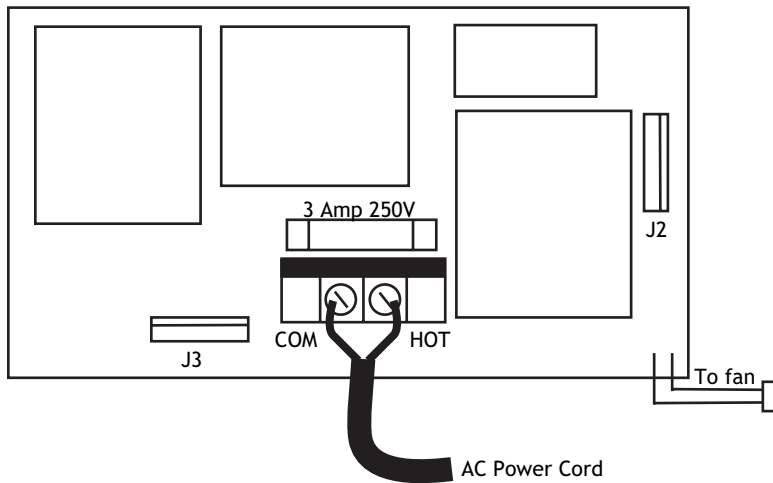

Installation



Always remove power to the SCS-1R Receiver when installing or removing the SCS-130.

1. Install the SCS-130 with J2 on the right side on the rear of the modem rack and J3 on the bottom as shown above. Four 6-32 screws with lock washers are provided.
2. Connect the SCS-208 Power Cable to J3 on the bottom left of the SCS-130 Transformer Card. Connect the other end of the power cable to the SCS-120 Multibus Power Supply. The power cable can be used in either direction.
3. Connect the cable from the right end of the modem rack labeled J2 to J2 on the right side of the SCS-130 Transformer Card.
4. Connect the 2-conductor cables labeled TO FAN to the multibus cooling fan on the lower right side of multibus rack.

AC Power Connection

Connect 120 VAC to the SCS-1R Receiver through the SCS-130 Transformer Card. The SCS-1R Receiver backplate provides a 7/8" conduit knockout.

1. Install the supplied strain relief onto the AC power cord approximately 12 inches from the AC wires.
2. Feed the end of the AC power cord through the backplate knockout until the strain relief snaps into place.
3. Connect the White AC power cord wire to the COM terminal on the bottom of the SCS-130.
4. Connect the Black AC power cord wire to the HOT terminal on the bottom of the SCS-130.
5. Connect the Green AC power cord ground wire to the grounding lug located on the right side of the enclosure.

The AC power must be provided by a listed UPS. A signal shall be provided at the operators console when the UPS power source switches from primary power to secondary power.

DO NOT APPLY POWER TO THE RECEIVER UNTIL THE REAR COVER IS REPLACED ON THE RECEIVER CABINET.

Three Amp Fuse

The 120 VAC connection to the SCS-1R Receiver is current limited with a DMP Model 319, 3 Amp 250 volt fuse. The 3 Amp fuse is a Type AGC 1/4" x 1 1/4" fast blow.

Model SCS-208 Power Cable

Description

The SCS-208 is a 2-foot cable that connects the different system voltages between the SCS-130 Transformer Card J3 and SCS-120 Multibus Power Supply Card J3.

Installation

The SCS-208 cable can be used in either direction, but is polarized on each end for proper installation to the J3 connectors.

Model SCS-203 Convenience Panel

Description

The SCS-203 provides cabling for three RS-232 ports for the host output, auxiliary port (used for Remote Link programming), and an activity log printer.

Installation

- 1) Install the metal plate with the three 25-pin RS-232 connectors on the SCS-1R Receiver backplate using the two 6-32 x 1/4" screws provided.
- 2) Install the three 10-pin flat cable connectors to the SCS-150 Receiver ports A1, A2, and A3.
 - a) Connect the ribbon cable marked A1(Activity Log) to port A1.
 - b) Connect the ribbon cable marked A2(Aux) to port A2.
 - c) Connect the ribbon cable marked A3 (Host Output) to port A3.
- 3) Connect the printer using a DMP Model 389 Printer Cable and host computer using a DMP model SCS-204 Host Cable (see below) to the appropriate RS-232 connectors.

Model SCS-204 Host Cable

Description

The SCS-204 is a 10-foot RS-232 cable that connects a host computer to the SCS-1R Receiver.

Installation

Connect the SCS-204 cable from a host computer to the SCS-203 Convenience Panel center connector marked "HOST OUTPUT".

THE END OF THE CABLE MARKED "HOST" MUST BE INSTALLED ONTO THE HOST COMPUTER.

Host Cable

If you are using a cable different from the SCS-204, be sure the cable pin out matches the drawing below.

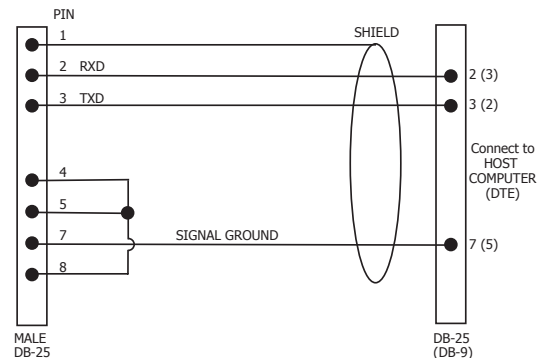

SCS-1R Printer Cable

Printer Cable Pinout

Note: UL central station applications must use a serial printer that is listed for Fire Protective Signaling Systems.

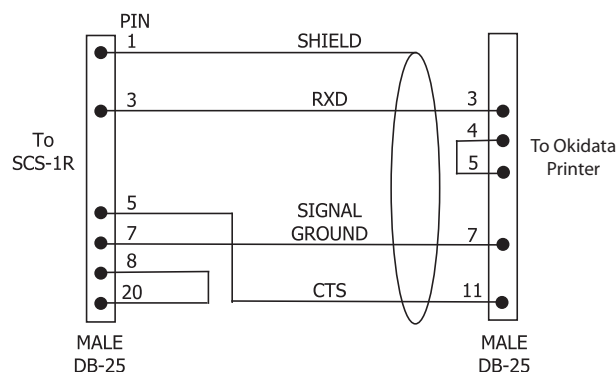

ULC Installation Recommendations

1. In order to give the digital alarm communicator transmitter the ability to disconnect an incoming call to the protected premises, telephone service should be of the type that provides for timed release disconnect.
2. Network access and domain access policies shall be set to restrict unauthorized network access and “spoofing” or “denial of service” attacks.
3. Select Internet Service Providers that have redundant servers/systems, Back-up power, Routers with Firewall enabled and Methods to identify and protect against “Denial of Service” attacks (i.e. via “spoofing”).
4. Power for network equipment as hubs, switches, routers, servers, modems, etc., shall be backed up or powered by an un-interruptible power supply (UPS), stand-by battery or the control unit, capable of facilitating 24 hour standby, compliant with Clauses 16.1.2 and 16.4.1 of CAN/ULC-S304-06.
5. Where such cannot be facilitated, the control unit shall support back-up communications for a secondary communications path, subject to the following:
 - Low Risk and Medium Risk shall use a dialer as a minimum;
 - High Risk shall use cellular control channel or long range radio as a minimum; and
 - Very High Risk shall be equipped with 24 Ah standby power. Note: Refer to Table 11 of CAN/ULC-S304-06 for the risk levels.
6. If the lines (numbers) are in a single hunt group (See definition in CAN/ULC-S304-06), they shall be individually accessible; otherwise, separate hunt groups shall be required. These lines shall be used for no other purpose than receiving signals from a digital alarm communicator transmitter. These lines (numbers) shall be unlisted.
7. Installation guidelines for communication channel security shall be provided with the control and/or communicator module to instruct on compliance to Subsection 15.2 of CAN/ULC-S304-06, Active Communication Channel Security.
8. Products or components of products used in communication channels, which perform communications functions only, shall comply with the requirements applicable to communications equipment as specified in CAN/CSA-C22.2 No. 60950-1, Information Technology Equipment-Safety - Part 1: General Requirements. Such products or components include, but are not limited to: Hubs, Routers, Network interface devices, Third party communications service providers, Digital subscriber line (DSL) modems, and Cable modems.
9. Communication devices powered by 24 hr UPS.
10. If the lines (numbers) are in a single hunt group (See definition in CAN/ULC-S304-06), they shall be individually accessible; otherwise, separate hunt groups shall be required. These lines shall be used for no other purpose than receiving signals from a digital alarm communicator transmitter. These lines (numbers) shall be unlisted.
11. A timed release disconnect requirement applies to the telephone lines (numbers) connected to the digital alarm communicator receiver. The numbers assigned to the digital alarm communicator receiver shall be individually accessible, even where they are connected in rotary (hunt group).
12. Receiver shall be connected to the signal receiving centre emergency electrical power supply per CAN/ULC-S301.

Security Control Terms

This is an alphabetical list of terms used in the SCS-1R Receiver system operating instructions. Refer to these explanations for additional information.

ACK - Acknowledge an alarm signal by pressing any top row Select key on the Membrane Keypad.

Alphanumeric - A set of characters consisting of either the letters A through Z, the digits 0 through 9, special symbols, or a combination of all of these. For example, the set of characters “AB76#2,” is alphanumeric.

Character - One of a set of symbols that can be arranged in groups to express information. This includes the digits 0 through 9, the letters A through Z, punctuation marks, and other special symbols.

Command Processor Programs - The data programmed into a DMP Command Processor™ panel at the time of installation. A typical program includes: communication information, system options, area information, Programs zone information, and the number and type of Security Command® keypads in the system. This should not be confused with System Programs that are software routines used by the SCS-1R to execute functions described in the Operations Manual.

COMMAND - The key on the Membrane Keypad used to scroll through programming and enter programming information.

LCD Membrane Keypad - A 32-character Liquid Character Display that displays information and provides a Membrane Keypad that allows you to enter information.

Default Value - A value assigned to a prompt by the SCS-1R. The SCS-1R Receiver assigns the value to that prompt allowing the operator to accept its entry and respond to the next prompt.

Entry - Information typed into the SCS-1R through the LCD Membrane Keypad mounted in the front of the SCS-1R. This information is entered into the system when the COMMAND key is pressed.

Prompt - A single item of information on the LCD. For example, a prompt within the System Configuration program would be the company name.

Menu - An LCD display that lists the program selections available to the operator.

Numeric - Description of numerical information. For example, the set of characters 1 2 3 4 5 is numeric.

User Number - The sequential number assigned to each user code number by the panel during its programming.

This is the number transmitted to the SCS-1R Receiver. The actual code number is never transmitted.

Using the LCD Membrane Keypad

Special Keys

COMMAND Key

The COMMAND key allows you to go forward through the configuration menu and each configuration step (or prompt). As you go through programming, the keypad display shows any current programming already stored in the panel memory. If the information does not need to be changed, press the COMMAND key to advance to the next step. After changing programming, press the COMMAND key to advance to the next option.

Back Arrow Key

Use the Back Arrow key to back up one step during programming. The Back Arrow key is also used when an error is made while entering information. Press the Back Arrow key once to erase the last character entered.

Select Keys

The top row of keys are called the Select keys. Each time a top row Select key is to be used, the keypad displays the function or options above the key. Displaying choices above the individual top row Select keys allows them to be used for many different applications. For example, you can enter AM or PM when programming time or answer YES or NO for a NET Option.

During programming, the top row Select keys also allow you to change information currently in the panel memory. Press the appropriate Select key under the display then enter the new information through the keypad.

The Select keys are also used for choosing a programming menu. Press any one of the top row Select keys when the name of the programming section you want displays.

When the SCS-1R system is in normal mode, the Select keys are used to acknowledge alarm messages. Press the Select key labeled ACK, or any top row Select key, to acknowledge the alarm message.

Keypad Prompts Display Current Programming

Each prompt displayed at the keypad shows the currently selected option in the panel memory. These options are either shown as a number, a blank, or NO or YES. To change a number or blank to a new number, press any top row Select key. An underscore replaces the current option. Press the number(s) on the keypad you want to enter as the new number for that prompt.

It is not necessary to enter numbers with leading zeros. The SCS-1R automatically right justifies the number when you press the COMMAND key.

To change a programming prompt that requires a NO or YES response, press the top row Select key under the response not selected.

For example, if the current prompt is selected as YES and you want to change it to NO, press the third top row Select key. The display changes to NO. Press the COMMAND key display the next prompt.

Entering Alpha Characters

You can use the keypad to enter alpha characters. To enter an alpha character, press the key that has the desired letter written below it. The keypad display shows the number on that key. To change the number to a letter, press the top row Select key that corresponds to the location of the letter under the key. For example, if you press key number 1, the letters for that key are A, B, and C. Press the first top row Select key for A, the second for B, and the third for C. See the figure below.

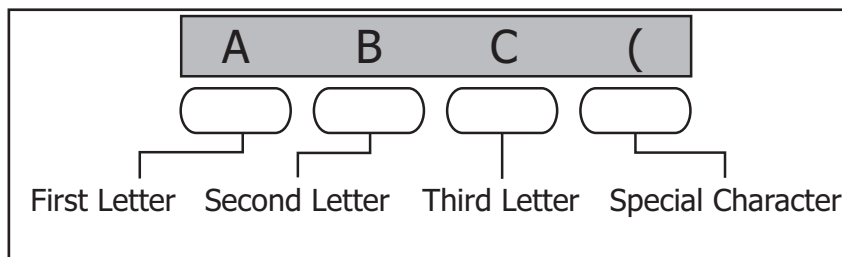

Entering Alphanumeric Characters

LCD Membrane Keypad Configuration

Internal Speaker Operation

The LCD Membrane Keypad speaker emits standard tones for key presses and alerts.

LCD Backlighting

The LCD backlighting turns on every time a key is pressed or the speaker sounds. The backlighting dims to medium brightness whenever the speaker is on.

Display Options

The LCD Membrane Keypad provides three keypad adjustments you can make to suit your environment.

To access the **Display Options** portion of the keypad, press and hold the Back Arrow and COMMAND keys for two seconds. The keypad display changes to **SET BRIGHTNESS**. Use the COMMAND key to display the next Option or press the Back Arrow key to exit the **Display Options** function.



Brightness

Set the keypad LCD Display brightness level and the AC Power LED. Use the left Select key to lower the keypad brightness and the right Select key to raise the brightness.

Note: If the brightness level is lowered, it reverts to maximum intensity whenever a key is pressed. If no keys are pressed, and the speaker has not sounded for 30 seconds, the user-selected brightness level restores.



Speaker Tone

Set the keypad internal speaker tone. At the SET TONE display, use the left Select key to lower the tone and the right Select key to raise the tone.



Volume Level

Set the keypad internal speaker volume level for key presses and entry delay tone conditions. During alarm and trouble conditions, the volume is always at maximum level. Use the left Select key to decrease the keypad volume and the right Select key to increase the volume. Press the COMMAND key to display the Model Number.



Model Number

The LCD displays the keypad firmware version and date. The user cannot change this information in User Options.

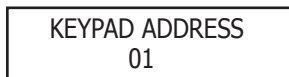

Keypad Address

The LCD displays the current keypad address. While in User Options, the user cannot change the keypad address. Press the Back Arrow key to exit the User Options function.

Keypad Options and Diagnostics

The SCS-LCD also contains **Options** and **Diagnostic** programs that allow you to configure and test keypad operation.

You can only access **Keypad Options** and **Diagnostics** through the Display Options. After holding down the Back Arrow and COMMAND keys for two seconds to display **SET BRIGHTNESS**, enter the code 3577 (INST) and press the COMMAND key. The display changes to **KPD OPT** (keypad options) **KPD DIAG** (keypad diagnostics) and **STOP**.

Keypad Options

KPD	KPD	
OPT	DIAG	STOP

Keypad Options (KPD OPT)

To program keypad options, press the left Select key under KPD OPT. The display changes to CURRENT KEYPAD ADDRESS: # #.

CURRENT KEYPAD ADDRESS:	01
----------------------------	----

Current Keypad Address

The Membrane Keypad must be set to keypad address 01. This is the default setting and should not be changed.

KEYPAD MODE:	
*SUP	UNSUP

Keypad Mode

The Membrane Keypad can be set for either Supervised or Unsupervised operation. It is recommended the setting be left at the default Supervised setting.

DEFAULT KEYPAD MSG:

Default Keypad Message

Press COMMAND to scroll past this option. The SCS-1R LCD Membrane Keypad does not provide a programmable Keypad Message.

ARM PANIC KEYS:		
PN	EM	F1

Arm Panic Keys

The Panic Keys should be disabled. They cannot be used on the SCS-1R LCD Membrane Keypad. If an asterisk appears next to one of the options, for example *PN, press the Select key under the option with the asterisk to remove the asterisk and disable the panic key.

ACTIVATE ZONE 2 SHUNT:	NO	YES
---------------------------	----	-----

Zone 2 Shunt

Leave this option set to NO.

ACTIVATE ZONE 3 EXIT:	NO	YES
--------------------------	----	-----

Zone 3 Exit

Leave this option set to NO.

4 DIGIT ENTRY CARDS:	NO	YES
-------------------------	----	-----

Entry Cards

Leave this option set to NO.

ALL?:	NO	YES
DELAY:	2	

All?

Leave this option set to NO.

Accessing Keypad Diagnostics

KPD	KPD	
OPT	DIAG	STOP

Keypad Diagnostics (KPD DIAG)

The Keypad Diagnostic option allows you to check the display segments, check the keyboard backlighting, and test individual keys.

Press the Select key under KPD DIAG. The keypad lights all display segments and illuminates the keyboard in green. A few seconds later the keypad turns the display off and illuminates the keyboard in red. The keypad then alternates between these two states for approximately two minutes. Press COMMAND at any time to continue.

PRESS KEY TO TEST

Test Individual Keys

The display changes to PRESS KEY TO TEST. This option allows you to test each key on the keyboard to ensure it is operating properly. Press and hold each key for about two seconds. The key number being held appears in the display. Verify the correct number displays before testing the next key.

Exiting the Installer Options

When done, press the COMMAND key once to return to the Installer Options screen. Press the Select key under STOP to exit the Installer Options function.

Status Displays and SCS-1R Programming

Receiver Startup Display

When the SCS-1R powers up, the display shows the software version and date of version release.

Time Display

During normal operation the display shows the current time. Press the Command button to enter the OFF-NORMAL menu.

Off-Normal Status

Displays previous Fire, Fire Verify, Burglary, and Supervisory zones that have not restored. In addition, supervised network (NET or CELL) accounts that are not communicating properly display here.

OFF-NORMAL?

Off-Normal

Press any top row Select key to view Off-Normal conditions. Press the COMMAND key to advance to the System Status menu. Press the Back Arrow key to return to normal standby mode.

OFF-NORMAL
ACCTS ZONES

Off-Normal Accounts and Zones

Press the far left Select key to view supervised accounts. Press the far right Select key to view non-restored zones.

112345 ZONE 123
FIRE ALARM

Off-Normal Zone Display Example

After pressing the top row Select key under ZONES, all non-restored zone messages display similar to the one shown on the left. The line number is listed first: line 1 in the example. The account number follows the line number: 12345. The zone number then displays: ZONE 123. The second line displays the zone type, Fire, Burglary, or Supervisory, followed by the event type, Alarm or Trouble: FIRE ALARM is the message in the example.

112345 ZONE 123
DELETE? NO YES

Delete Off-Normal Zone Instance

When an off-normal zone displays, pressing any top row Select key can delete the zone off normal status from the SCS-1R. Press the top row Select key under YES to delete, or NO to save the message and return to the previous display. Default is NO.

112345 NET ACCT
NOT RESPONDING

Off-Normal Account Display Example

After pressing the Select key under ACCTS, all off normal supervised accounts display a message similar to the one shown on the left. The line number is listed first: line 1 in the example. The account number follows the line number: 12345. The example message then displays: Network Account not Responding.

112345 NET ACCT
DELETE? NO YES

Delete Off-Normal Account Instance

When an off-normal account message displays, pressing any top row Select key can delete this display from the SCS-1R. Press the top row Select key under YES to delete, or NO to save the message and return to the last display. Default is NO.

OFF-NORMAL
END OF LIST

End of List

This displays when the end of the Off-Normal list has been reached.

System Status

The System Status section displays the number of calls since 12:00 AM for each line card programmed for Digital Dialer (DD) communication.

SCS-1R MENU
SYSTEM STATUS?

System Status

Press any top row Select key to view System Status. Press the COMMAND key to advance to the next programming section. Press the Back Arrow key to return to the Off-Normal programming section.

LINE X
NO OF CALLS: XXXX

Number of Calls

This displays the number of calls the line has received since midnight. Lines 1 through 5 display if they are DD lines. XXXX in the second line of the display represents the number of calls. Press the COMMAND key to advance to the next DD line card. If no more DD line cards display, the display advances to the programming menu.

NO DD LINES

No DD Lines

Displays for four seconds if no DD lines are programmed.

Programming Through Remote Link

Programming of the SCS-150 can be performed using Remote Link version 1.47 or higher. Connect the computer with Remote Link installed to the 25-pin connector Auxiliary Port on the back of the SCS-1R Receiver using an SCS-204 cable.

Note: Each SCS-150 programming section in Remote Link is independent and changes should be sent to the receiver after programming is completed for each window.

Programming Menu

Allows entry to the programming menu for the SCS-1R using the keypad display.

MENU? NO YES

Menu?

Select YES to enter the programming code. Select NO to return to the Time Display.

ENTER CODE: 6653

Programming Code

Enter PROG (6653) to enter the Programming Menu.

Service Code (XR500 Series panels)

This option allows the entry of a 5-digit service authorization code used to authenticate service personnel before allowing access to panel programming or performing any user operations.

SCS-1R MENU
SERVICE CODE

Service Code (XR500 Series panels)

Press any top row Select key to enter the Service Code. Press the COMMAND key to advance to the next section of programming.

SERVICE CODE
00000

Range for the 5-digit code is 00000-65535. When this feature is enabled on an XR500 Series panel a service person is required to enter a valid service user code for system programming access. Once the code is authenticated with the receiver, access to panel programming is granted. If the code is not authenticated, access is denied.

The receiver cannot authenticate service personnel until a number is entered at this option. Entering 00000 at the receiver disables this operation and panel access is always granted.

Note: This panel operation is available to purchase for XR500 Series panels with version 108 or higher software. Refer to the Feature Upgrade section in the XR500 Series Programming Guide (LT-0679) for additional information.

Receiver Options

This section assigns the company name and system number as well as the communication type for each SCS-1R Receiver incoming line.

SCS-1R MENU
RECEIVER OPTIONS

Receiver Options

Press any top row Select key to display the company name and configure the system. Press the COMMAND key to advance to the next section of programming.

COMPANY NAME
-

Company Name

Enter your company name using two lines, each line can have up to 16 characters. Enter the first 16 characters and press the COMMAND key to accept.

COMPANY NAME 2
-

Enter the second 16 characters and press the COMMAND key to accept.

RECEIVER SYSTEM
NUMBER: 1

Receiver System Number

The LCD displays the current receiver system number. Press any top row Select key, then enter the system number, 0 through 9. The default System Number is 1. Press the COMMAND key when finished.

Note: This identifier is used by the automation computer to distinguish between multiple SCS-1R systems.

RECEIVER KEY
KEY:*****

Receiver Key

The current Receiver Key displays. Press the COMMAND key to leave the Receiver key the same and move to the next programming option. Press any top row Select key to change the Receiver Key.

Note: This is an eight-character alphanumeric entry. This key is requested by Command Processor™ panels in the field when using remote programming from this receiver. Once entered this key does not display and should never be changed. Record this number in the Important information Sheet at the end of this document and store in a secure place.

Enter the new Receiver Key up to eight characters long. Press the COMMAND key to display the next prompt.

CHANGE REC KEY
SURE? YES NO

Change Receiver Key

After entering the desired Receiver Key and pressing COMMAND, the SURE? YES NO prompt displays. Press the Select key under YES to keep the new key, or under NO to use the previously stored key.

RECEIVER KEY
CHANGED

Receiver Key Changed

After pressing the Select key under YES, the display indicates that the receiver key has been successfully changed.

RECEIVER HOURS
FROM GMT: 6

Receiver Hours From GMT

Number of hours (0 to 23), from the Greenwich Time zone (GMT), where the receiver is located. Refer to the table below for various cities and GMT settings. Default is 6.

GMT	City/Time Zone
0	London, Monrovia, Lisbon, Dublin, Casablanca, Edinburgh
1	Cape Verde Island, Azores
2	Mid-Atlantic, Fernando de Noronha
3	Buenos Aires, Georgetown, Brasilia, Rio de Janeiro
4	Atlantic Time (Canada), Caracas, La Paz, Santiago
5	Eastern Time (US, Canada) Bogota, Lima, Arequipa
6	Central Time (US, Canada), Mexico City, Saskatchewan
7	Mountain Time (US, Canada), Edmonton
8	Pacific Time (US, Canada), Tijuana
9	Alaska
10	Hawaii
11	Midway Island, Samoa
12	Fiji, Marshall Island, Wellington, Auckland, Kwajalein, Kamchatka

GMT	City/Time Zone
13	New Cadelonia
14	Guam, Sydney
15	Tokyo, Seoul
16	Hong Kong, Singapore
17	Bangkok, Hanoi
18	Dhaka, Almaty
19	Islamabad, Karachi
20	Abu Dhabi, Kazan
21	Moscow, Bagdad
22	Eastern Europe
23	Rome, Paris, Berlin

DIALER LINE CARD
MONITOR? NO YES

Dialer Line Card Monitor

Press the far right Select key for YES to enable monitoring of all SCS-100 digital dialer line cards for any failed communication attempts. A failed communication attempt occurs when the line card goes off hook but does not successfully communicate with a panel. Press the middle right Select key for NO, to disable the line card monitoring operation. Default is NO.

When enabled, and a line card communication fails, a message, S61 through S65 (Line 1-5 respectively), is sent to the host automation computer, SCS-1R printer and LCD display. Manual acknowledgement is required when the SCS-1R is not successfully communicating with the host automation computer.

Line Cards

This section assigns the line number and line type for all line cards connected to the SCS-150.

SCS-1R MENU
LINE CARDS

Line Cards

Press any top row Select key to assign the line number and line type for each line card connected to the SCS-150.

LINE NUMBER: X

Line Number

Press any top row Select key to clear the display and enter a new line number. Enter the line number, 1 through 5, for which the communication method is to be specified.

LINE NUMBER: X
TYPE: XXXX

Line Type

The display shows the current setting for the line type. Press any top row Select key to change the Line Type. Press the Select key under the communication method for this line. NET for Data Network communication for use with data networks. DD for DMP Digital Dialer. NONE to clear all information for the line. Line 1 defaults to NET and lines 2 through 5 default to DD. After you select the line type, the display returns to LINE NUMBER: to program the other lines.

LINE TYPE
NONE DD NET

SEND TIME CHANGE
TO PNLs? NO YES

Send Time Change

Press the top row Select key under YES to allow the SCS-1R to send time changes to panels that communicate to the receiver on this line card. Select NO to prevent the SCS-1R Receiver from sending time changes.

Host Automation

The SCS-1R Host Automation programming section allows adjustments to optimize the SCS-1R performance with the host automation computer. The display shows the current setting for each prompt. Press any top row Select key to clear the display and enter the new information.

SCS-1R MENU
HOST AUTOMATION

Host Automation

Press any top row Select key to program Host Automation settings. Press the COMMAND key to advance to the next programming section. Press the Back Arrow key to return to the previous section.

HOST NAME

Host Name

Enter a Host Name up to 16 characters. When done, press Command to accept name and continue to START CHARACTER.

START CHARACTER :
NONE

Start Character

Enter the character to be used at the start of a host message. Enter None or 01-31. Default is NONE.

CRC ERROR CHECK?
NO YES

CRC Error Check

Press the far right Select key for YES, which allows each message sent to the host to be prefixed with an SIA CIS CRC-16. The format is 4 hexadecimal characters. Default is NO.

SEQUENCE NUMBER?
NO YES

Sequence Number

Press the far right Select key for YES, which sends each message sent to the host with a sequence number ranging from 1 to 99. Default is NO.

TEST INTERVAL:
MINUTES: 1

Test Interval

Press any top row Select key to clear the display and enter the new Test Interval. Enter the number of minutes, 1 through 60, between communication test messages (S99) of the SCS-1R Receiver and host computer. Default is 1 (one).

ACKNOWLEDGE
TIMEOUT: 03

Acknowledge Timeout

Press any top row Select key to clear the display and enter the new Acknowledge Timeout. This is the time in seconds, 1 through 15, the SCS-1R waits for a host acknowledgment of a message before transmitting it again. Default is 3 (three).

LINE NUMBER
LENGTH: 0

Line Number Length

Press any top row Select key to clear the display and enter the new Line Number Length. Enter the number of decimal ASCII characters, 0 (zero) through 2, used to report the SCS-1R Receiver signal line number. Default is 0 (zero).

RETRIES TO
FAILURE: 5

Retries to Failure

Press any top row Select key to clear the display. Enter the number of attempts, between 1 and 15, the SCS-1R makes to transmit a message to the host computer. When this number is reached, the SCS-1R begins manual acknowledgement operation. Default is 5 (five).

Serial Ports

The SCS-1R Serial Ports section allows you to make adjustments to the Host Output, Activity Log, and Print Operation Serial Port.

SCS-1R MENU
SERIAL PORTS

Serial Ports

Press any top row Select key to program the Serial Port settings. Press the COMMAND key to advance to the next programming section. Press the Back Arrow key to return to the previous section.

HOST OUTPUT BAUD
RATE: 9600

Host Output Baud Rate

Press any top row Select key to change the Host Output Baud Rate. Enter 300, 600, 1200, 2400, 4800, 9600, or 19200. Press the Command button to accept. Default is 9600.

ACTIVITY LOG BAUD
RATE: 1200

Activity Log Baud Rate

Press any top row Select key to change the Activity Log Baud Rate. Enter 300, 600, 1200, 2400, 4800, 9600, or 19200. Press the Command button to accept. Default is 1200.

PRINT OPERATION:
ALWAYS

Print Operation

Press any top row Select key to change the Print Operation. Select ALWAYS to enable the Activity Log output for all system events. Select NEVER to disable the Activity Log. Select FAIL to enable only when Host Automation has failed and is not acknowledging messages from the receiver.

PRINT OPERATION
ALWAYS NEVER FAIL

Set System Time/Date

This selection allows you to set the correct time and date on the SCS-1R. All changes made in this selection print to the Activity Log printer. The time entered here is sent to panels if the Time Change programming option is set to YES.

SCS-1R MENU
TIME/DATE

Time/Date

Press any top row Select key to display the time and date. Press the COMMAND key to advance to the next section of programming.

TUE 12:05 PM
04/07/09

Current Time/Day/Date

Press the COMMAND key to program the time and/or date. Press the Back Arrow key to return to the previous display.

SET TIME/DATE
TIME DATE

Set Time/Date

Press the top row Select key under the item you would like to change. For example, press the far left Select key to change the SCS-1R time.

ENTER TIME:
- : AM PM

Time

Press any top row Select key to enter the new time. Using the Digit keys on the keypad, enter the current time and then press Select key under AM or PM. TIME CHANGED displays after the time has been changed.

ENTER DATE:
- / /

Date

Press any top row Select key to enter the date. Enter the month, date, and year in the following format: MM/DD/YY, with leading zeroes. Press COMMAND to accept the date and display the following prompt.

TIME CHANGED

Time/Date Changed

If the Time or Date has been changed successfully, the display will show TIME/DATE CHANGED.

Exit Programming Menu

Exit Menu allows you to properly end programming and exit the menu.

SCS-1R MENU
STOP

Exit Menu

Press any top row Select key to exit the SCS-1R menu.

Printout Explanations

General Description

Note: UL central station applications must use a serial printer listed for Fire Protective Signaling Systems.

The SCS-1R prints out two general types of messages: changes in the system information and messages received from DMP Command Processor panels. The message line for system changes is bracketed by double asterisks with the time of occurrence printed at the far right. Messages from panels always list the account number first followed by the message and the time of occurrence. The printout below is a typical page from an Activity Log.

ATLAS SECURITY SERVICE, INCORPORATED						Page number:	2
Wednesday	5/1/03	** ACTIVITY LOG **					
**	**	SECURITY CONTROL SYSTEM NUMBER CHANGED TO: 1.				**	8:01 a.m.
**	**	LINE: 3 CONFIGURED AS: DD	PHONE NUMBER: (214) 555-1212		**	8:02 a.m.	
**	**	DIALER PANEL NUMBER: 108 ADDED TO LINE: 1				**	8:04 a.m.
1-	1	Zone: 8 FRONT DOOR	-	BURG	ALARM		8:18 a.m.
1-	1	Zone: 2 BACK DOOR	-	BURG	TROUBLE		8:23 a.m.
1-	1	Zone: 2 BACK DOOR	-	BURG	RESTORE		8:24 a.m.
1-	1	* * AMBUSH * *					8:27 a.m.
1-	1	Area: 1 OFFICE	-	DISARMED	Usr: 007		8:31 a.m.
		2 PLANT					
		3 SHIPPING					
1-	1	Zone: 010 FRONT DOOR	-	BYP	Usr: 015		8:33 a.m.
1-	1	Usr: 009 added to panel			Usr: 002		8:33 a.m.
1-	1	Permanent schedule for Tuesday Area: 1					8:35 a.m.
		Open: 8:00 a.m.	Close: 5:30 p.m.		Usr: 005		
1-	1	Door access Dr: 001		Usr: 021			8:36 a.m.
1-	1	WARNING: Low standby battery					8:38 a.m.
1-	1	Zone: 37 SMOKE DET.	-	FIRE	ALARM		8:40 a.m.

System Messages

System messages are provided on the Activity Log printer to provide a permanent record of changes made to the system information. The operator making the change is determined by referring to the last sign on.

Command Processor Messages

Messages from Command Processor panels are sent to the SCS-1R advising of various changes in the panel status. The messages print and/or display on the LCD.

Alarm, Trouble, and Restore

These messages are all formatted the same. Alarm and Trouble messages print to the Activity Log and display on the LCD for acknowledgment.

Fire and Supervisory restorals display on the LCD for acknowledgment and printed to the Activity Log while other restore messages print to the Activity Log only.

Ambush

The Ambush message prints and displays on the LCD for acknowledgment.

Opening and Closing

Openings and Closings reports list the areas that are armed or disarmed and the user name making the change. These messages can be from 1 to 8 consecutive lines and print to the Activity Log only.

Bypass and Reset

This message prints in a one line format listing the zone number, zone name, and user name making the change. The message prints on the Activity Log only.

Schedule Changes

This prints in a 2-line format listing the type of schedule, day of the week, opening and closing time, and the user name making the change. This message prints on the Activity Log only.

Door Access

This message lists the user name accessing the door strike relay and the door number that is being accessed. The door number matches the keypad address operated by the user. This message prints on the Activity Log only.

Acknowledgment of Fire Alarms and Troubles

This message is listed each time the operator acknowledges a fire type zone alarm or trouble message. The message includes the account number, zone number, and the acknowledged condition.

Message Destinations

Message	Activity Log	LCD
Time/Date	X	
System Number	X	
Telephone Line Configuration	X	
Zone Alarm	X	X
Zone Trouble	X	X
Zone Restore	X	*
Ambush	X	X
Opening and Closing	X	
Bypass and Reset	X	
Add and Delete Codes	X	
Schedule Changes	X	
System Messages	X	X
Door Access	X	
* Fire and supervisory type zones restorals are the only restorals that display on the LCD for acknowledgement.		

Printer Troubleshooting

Activity Log ERROR

When the SCS-1R cannot complete printing a message to the Activity Log printer, this alarm message displays on the LCD for acknowledgment. Possible causes of failure are:

Power Light Not Lit

Check AC outlet. If the outlet is good, check the internal circuit breaker and fuse located on the left rear corner of the printer.

SEL Light Not Lit

Press the SEL switch to light the SEL light. If the light does not come on, turn the unit off for five seconds and try again.

PAPER Light Lit

In this case the SEL light cannot be lit and paper must be added.

Bad Printer Cable

If the printer can complete a test printing and installing a dummy plug at the rear of the SCS-1R can silence an alarm, the printer cable has been damaged.

If none of the above are the cause for the activity log error, contact DMP Technical Support at:

1-888-4DMPTEC (1-888-436-7832)

If calling internationally, dial 1-417-831-9362

Note: Installation of a dummy plug, which shorts pins 4 and 5, causes all messages waiting to be printed and all messages received while it is installed will not be printed.

Important Information

Use the table below to record the receiver key for your SCS-1R Receiver. Keep this sheet and the rest of the manual in a safe location for future reference.

Receiver Key _____

Notes:

<p>Components</p> <table style="width: 100%; border-collapse: collapse;"> <tr><td style="width: 15%;">SCS-RACK</td><td>System Enclosure</td></tr> <tr><td>SCS1R-Spares</td><td>Spare Board kit</td></tr> <tr><td>SCS-100</td><td>Line Card</td></tr> <tr><td>SCS-101</td><td>Network Line Card</td></tr> <tr><td>SCS-110</td><td>Modem Power Card</td></tr> <tr><td>SCS-120</td><td>Multibus Power Card</td></tr> <tr><td>SCS-130</td><td>Transformer Card</td></tr> <tr><td>SCS-203</td><td>Convenience Panel</td></tr> <tr><td>SCS-204</td><td>Host Cable</td></tr> <tr><td>SCS-208</td><td>Power Cord</td></tr> <tr><td>SCS-150</td><td>Receiver Processor Board</td></tr> </table> <p>Accessory Devices</p> <table style="width: 100%; border-collapse: collapse;"> <tr><td style="width: 15%;">SG-DPU-414</td><td>Printer with Power Supply and Cable</td></tr> <tr><td>SCS-186T</td><td>Printer with Cable (Non-UL)</td></tr> </table>	SCS-RACK	System Enclosure	SCS1R-Spares	Spare Board kit	SCS-100	Line Card	SCS-101	Network Line Card	SCS-110	Modem Power Card	SCS-120	Multibus Power Card	SCS-130	Transformer Card	SCS-203	Convenience Panel	SCS-204	Host Cable	SCS-208	Power Cord	SCS-150	Receiver Processor Board	SG-DPU-414	Printer with Power Supply and Cable	SCS-186T	Printer with Cable (Non-UL)	<p>Listings and Approvals</p> <p>FCC Part 15 FCC Part 68 Registration ID CCK8GW-16197-AL-N California State Fire Marshal (CSFM) New York City (FDNY COA #6055)</p> <p>Underwriters Laboratories (UL) Listed</p> <table style="width: 100%; border-collapse: collapse;"> <tr><td style="width: 30%;">ANSI/UL 864</td><td>Fire-protective Signaling</td></tr> <tr><td>ANSI/UL 1635</td><td>Digital Alarm Communicator</td></tr> <tr><td>ANSI/UL 1610</td><td>Central-station Burglar</td></tr> <tr><td>ANSI/UL 365</td><td>Police Station Connected Burglar</td></tr> <tr><td>ANSI/UL 1076</td><td>Proprietary Burglar</td></tr> </table> <p>Underwriters Laboratories Canada (ULC) Listed</p> <table style="width: 100%; border-collapse: collapse;"> <tr><td style="width: 30%;">ULC-S545</td><td>Standard for Residential Fire Warning System Control Units</td></tr> <tr><td>ULC-S304-06</td><td>Standard for Central and Monitoring Station Burglar Alarm Units</td></tr> <tr><td>ULC-C1023</td><td>Household Burglar Alarm System Units</td></tr> <tr><td>ULC/ORD-C1076</td><td>Standard for Proprietary Burglar Alarm Units and Systems</td></tr> </table> <p>For additional information, access www.dmp.com and select Compliance.</p>	ANSI/UL 864	Fire-protective Signaling	ANSI/UL 1635	Digital Alarm Communicator	ANSI/UL 1610	Central-station Burglar	ANSI/UL 365	Police Station Connected Burglar	ANSI/UL 1076	Proprietary Burglar	ULC-S545	Standard for Residential Fire Warning System Control Units	ULC-S304-06	Standard for Central and Monitoring Station Burglar Alarm Units	ULC-C1023	Household Burglar Alarm System Units	ULC/ORD-C1076	Standard for Proprietary Burglar Alarm Units and Systems
SCS-RACK	System Enclosure																																												
SCS1R-Spares	Spare Board kit																																												
SCS-100	Line Card																																												
SCS-101	Network Line Card																																												
SCS-110	Modem Power Card																																												
SCS-120	Multibus Power Card																																												
SCS-130	Transformer Card																																												
SCS-203	Convenience Panel																																												
SCS-204	Host Cable																																												
SCS-208	Power Cord																																												
SCS-150	Receiver Processor Board																																												
SG-DPU-414	Printer with Power Supply and Cable																																												
SCS-186T	Printer with Cable (Non-UL)																																												
ANSI/UL 864	Fire-protective Signaling																																												
ANSI/UL 1635	Digital Alarm Communicator																																												
ANSI/UL 1610	Central-station Burglar																																												
ANSI/UL 365	Police Station Connected Burglar																																												
ANSI/UL 1076	Proprietary Burglar																																												
ULC-S545	Standard for Residential Fire Warning System Control Units																																												
ULC-S304-06	Standard for Central and Monitoring Station Burglar Alarm Units																																												
ULC-C1023	Household Burglar Alarm System Units																																												
ULC/ORD-C1076	Standard for Proprietary Burglar Alarm Units and Systems																																												
	<p>800-641-4282</p> <p>www.dmp.com</p> <p>Made in the USA</p>	<p>INTRUSION • FIRE • ACCESS • NETWORKS</p> <p>2500 North Partnership Boulevard</p> <p>Springfield, Missouri 65803-8877</p>																																											

LT-1037 1.03 © 2009 Digital Monitoring Products, Inc. 9456

 MADE IN U.S.A.