

Nozzle Cleaning Tool

A clogged spray nozzle may produce a poor spray pattern.

Nozzle Cleaning Instructions

⚠ WARNING

SHUT OFF WASHER AND PULL GUN TRIGGER TO RELIEVE FLUID PRESSURE BEFORE STARTING CLEANING PROCEDURE.

Remove wand from gun. Place nozzle cleaning tool in end of nozzle and push through hole to dislodge obstruction. Backflush water or blow air through nozzle to remove material. Repeat if required. Attach tool to pressure washer with locking tie for future use.

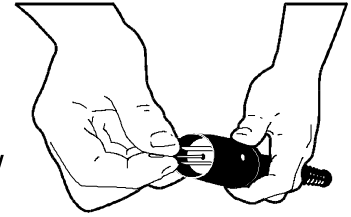

DeVilbiss Air Power Company

OWNERS MANUAL FOR PRESSURE WASHER Model No. W1218

SPECIFICATION CHART

MODEL	W1218
PUMP PRESSURE	1250 P.S.I. MAX
FLOW RATE	1.8 G.P.M.
VOLTAGE REQUIREMENT	120V/15 AMP/60HZ
MINIMUM FUSE SIZE	15 AMP., TIME DELAY
POWER CORD	35' WITH GFCI (GROUND FAULT CIRCUIT INTERRUPTER)
HOSE	25' SWIVEL HIGH PRESSURE HOSE
PKG. WEIGHT	40 LBS.

IMPORTANT:

READ AND RETAIN THE SAFETY GUIDELINES AND ALL INSTRUCTIONS CAREFULLY BEFORE OPERATING

TABLE OF CONTENTS

	<i>PAGE</i>
WARRANTY STATEMENT	3
SAFETY GUIDELINES	4
IMPORTANT SAFETY INSTRUCTIONS.....	4-5
GLOSSARY	6
GROUNDING INSTRUCTIONS/EXTENSION CORDS	6
OPERATING INSTRUCTIONS.....	7
MAINTENANCE & STORAGE	8
TROUBLE SHOOTING GUIDE.....	9
ACCESSORIES/CLEANING SOLUTIONS/ SERVICE PARTS	10-11

In the unlikely event you should have a problem with this product or if you are missing any parts, it is not necessary to return it to the store where you purchased it.

CALL TOLL-FREE 1-800-888-2468, EXT. 2

LIMITED WARRANTY

ONE YEAR FROM DATE OF PURCHASE

All merchandise manufactured by DeVilbiss Air Power Company is warranted to be free of defects in workmanship and material which occur during the first year from the date of purchase by the original purchaser (initial user). Products covered under this warranty include: air compressors, *air tools, accessories, service parts, pressure washers, and generators used in consumer applications (i.e., personal residential household usage only).

Air compressors, *air tools, accessories, service parts, pressure washers, and generators used in commercial applications (income producing) are covered by a 90 day warranty.

DeVilbiss Air Power will repair or replace, at DeVilbiss's option, products or components which have failed within the warranty period. Repair or replacement, and service calls on 60 and 80 gallon air compressors, will be handled by Authorized Warranty Service Centers and will be scheduled and serviced according to the normal work flow and business hours at the service center location, and depending on the availability of replacement parts.

All decisions of DeVilbiss Air Power Company with regard to this policy shall be final.

This warranty gives you specific legal rights, and you may also have other rights which vary from state to state.

RESPONSIBILITY OF ORIGINAL PURCHASER (Initial User):

- Retain original cash register sales receipt as proof of purchase for warranty work.
- Use reasonable care in the operation and maintenance of the product as described in the Owners Manual(s).
- Deliver or ship the product to the nearest DeVilbiss Air Power Authorized Warranty Service Center. Freight costs, if any, must be paid by the purchaser.
- Air compressors with 60 and 80 gallon tanks only will be inspected at the site of installation. Contact the nearest Authorized Warranty Service Center, that provides on-site service calls, for service call arrangement.
- If the purchaser does not receive satisfactory results from the Authorized Warranty Service Center, the purchaser should contact DeVilbiss Air Power Company.

THIS WARRANTY DOES NOT COVER:

- Merchandise sold as reconditioned, floor models and/or display models. Any damaged or incomplete equipment sold "as is".
- Merchandise used as "rental" equipment.
- Merchandise that has become inoperative because of ordinary wear, misuse, freeze damage, use of improper chemicals, negligence, accident, improper and/or unauthorized repair or alterations including failure to operate the product in accordance with the instructions provided in the Owners Manual (s) supplied with the product. *Air Tools: O-Rings and driver blades are considered ordinary wear parts, therefore, they are warranted for a period of 45 days from the date of purchase.
- An air compressor that pumps air more than 50% during a one hour period is considered misuse because the air compressor is undersized for the required air demand. Maximum compressor pumping time per hour is 30 minutes.
- Merchandise sold by DeVilbiss Air Power which has been manufactured by and identified as the product of another company. The product manufacturer's warranty will apply.
- Repair and transportation costs of merchandise determined not to be defective.
- Cost associated with assembly, required oil, adjustments or other installation and start-up cost.
- ANY INCIDENTAL, INDIRECT OR CONSEQUENTIAL LOSS, DAMAGE, OR EXPENSE THAT MAY RESULT FROM ANY DEFECT, FAILURE OR MALFUNCTION OF THE PRODUCT.** Some states do not allow the exclusion or limitation of incidental or consequential damages, so the above limitation or exclusion may not apply to you.
- IMPLIED WARRANTIES, INCLUDING THOSE OF MERCHANTABILITY AND FITNESS FOR A PARTICULAR PURPOSE, ARE LIMITED TO ONE YEAR FROM THE DATE OF ORIGINAL PURCHASE.** Some states do not allow limitations on how long an implied warranty lasts, so the above limitations may not apply to you.

DeVilbiss Air Power Company

213 Industrial Drive • Jackson, TN 38301-9615 • Telephone: 1-800-888-2468, Ext. 2 • FAX: 1-800-888-9036

SAFETY GUIDELINES - DEFINITIONS

<p>This manual contains information that is important for you to know and understand. This information relates to protecting YOUR SAFETY and PREVENTING EQUIPMENT PROBLEMS. To help you recognize this information, we use symbols to the right. Please read the manual and pay attention to these sections.</p>	<div style="border: 1px solid black; display: inline-block; padding: 2px 5px;">⚠ DANGER</div>	<div style="border: 1px solid black; display: inline-block; padding: 2px 5px;">⚠ CAUTION</div>
	<p>URGENT SAFETY INFORMATION - A HAZARD THAT WILL CAUSE SERIOUS INJURY OR LOSS OF LIFE</p>	<p>Information for preventing damage to equipment.</p>
	<div style="border: 1px solid black; display: inline-block; padding: 2px 5px;">⚠ WARNING</div>	<div style="border: 1px solid black; display: inline-block; padding: 2px 5px;">NOTE</div>
	<p>IMPORTANT SAFETY INFORMATION - A HAZARD THAT <i>MIGHT</i> CAUSE SERIOUS INJURY OR LOSS OF LIFE.</p>	<p>Information that you should pay special attention to.</p>

IMPORTANT SAFETY INSTRUCTIONS

- SAVE THESE INSTRUCTIONS •

⚠ WARNING



When using this product basic precautions should always be followed including the following:







1. **Read and understand all the instructions before using the product.**
2. To reduce the risk of injury, close supervision is necessary when a product is used near children.
3. Know how to stop the product and bleed pressures quickly. Be thoroughly familiar with the controls.
4. Stay alert – watch what you are doing.
5. Do not operate the product when fatigued or under the influence of alcohol or drugs.
6. Keep operating area clear of all persons.
7. Do not overreach or stand on unstable support. Keep good footing at all times.
8. Follow the maintenance instructions specified in the manual.
9. "This Product Is Provided With A Ground Fault Circuit Interrupter Built Into The Power Cord Plug. If Replacement Of The Plug or Cord is Needed, Use Only Identical Replacement Parts."
10. **⚠ WARNING – Risk of Injection or Injury – Do Not Direct Discharge Stream At Persons."**

HAZARD	WHAT COULD HAPPEN	HOW TO PREVENT IT
<div style="background-color: black; color: white; padding: 2px; display: inline-block;">⚠ DANGER</div> RISK OF ELECTRICAL SHOCK 	<ul style="list-style-type: none"> ■ This product is powered by electricity. It contains and sprays water and other conductive liquids. Improper operation could result in electrocution. ■ The Ground Fault Circuit Interrupter (GFI) will not function properly unless connected to a fully grounded electrical circuit! ■ Spraying directed at electrical outlets or switches, or objects connected to electrical circuit could result in electrical shock. ■ Extension cords of improper size or in poor condition can lead to electrical shock. 	<ul style="list-style-type: none"> ■ Always connect cordset to a properly grounded and polarized electrical circuit. Your cordset is equipped with a Ground Fault Circuit Interrupter (GFCI) for your personal protection. If damaged, the entire cordset assembly must be replaced by an authorized service center. Refer to Grounding Instructions on page 6. ■ Unplug any electrically operated product before attempting to clean it. Direct spray away from electric outlets and switches. ■ Always keep cord connections dry. Never attempt to assemble connections with wet hands. See section on Grounding Instructions/Extension Cords. (Page 6)

IMPORTANT SAFETY INSTRUCTIONS (cont'd)

⚠ WARNING

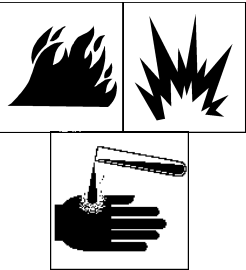
HAZARD	WHAT COULD HAPPEN	HOW TO PREVENT IT
<p>⚠ WARNING RISK OF FLUID INJECTION</p> 	<ul style="list-style-type: none"> ■ Your washer operates at fluid pressures and velocities high enough to penetrate human and animal flesh, which could result in serious injury or amputation. Leaks caused by loose fittings or worn or damaged hoses can result in injection injuries. DO NOT TREAT FLUID INJECTION AS A SIMPLE CUT! Fluid injection can lead to amputation. See a physician immediately. 	<ul style="list-style-type: none"> ■ Never place hands in front of nozzle. Keep operating area clear of all persons. Direct spray away from self and others. Make sure hose and fittings are tightened and in good condition. Never hold on to the hose or fittings during operation.
<p>⚠ WARNING RISK OF INJURY FROM SPRAY</p> 	<ul style="list-style-type: none"> ■ High velocity fluid spray can cause some objects to break, projecting particles at high speed. Light or unsecured objects can become hazardous projectiles. 	<ul style="list-style-type: none"> ■ Always wear ANSI approved Z87 safety glasses. Keep children and others away from work area. Remove loose objects from spray path. Secure light objects to be cleaned. ■ Direct spray away from self and others. ■ Always secure trigger lock when wand is not in service to prevent accidental triggering (actuation, etc...).
<p>⚠ WARNING RISK OF INJURY FROM WAND RECOIL</p> 	<ul style="list-style-type: none"> ■ Reactive force of spray will cause wand to move, and could cause the operator to slip or fall, or misdirect the spray. Improper control of wand can result in injuries to self and others. 	<ul style="list-style-type: none"> ■ Keep work area free of obstacles. Assume a solid stance on stable surface. Keep a firm grip on the wand and expect it to kick when triggered. ■ Only use cleaning fluids specifically recommended for use in high pressure washers.
<p>⚠ WARNING RISK TO BREATHING</p> 	<ul style="list-style-type: none"> ■ Some cleaning fluids contain substances which could cause injury to skin, eyes, or lungs. ■ Never use this product to spray toxic or corrosive materials such as poisons, insecticides, etc. 	<ul style="list-style-type: none"> ■ Wear protective clothing to protect eyes and skin from contact with sprayed materials. Work in a well ventilated area.
<p>⚠ WARNING RISK OF EXPLOSION OR FIRE</p> 	<ul style="list-style-type: none"> ■ Use of acids, unapproved chemicals, or flammable solvents with this product could cause injury or death. 	<ul style="list-style-type: none"> ■ Do not use acids, gasoline, kerosene, or any other flammable materials in this product. Use only household detergents, cleaners and degreasers recommended for use in Pressure Washer. Work in a well ventilated area.

• SAVE THESE INSTRUCTIONS •

GLOSSARY

GFCI: (GROUND FAULT CIRCUIT INTERRUPTER) This pressure washer is equipped with a GFCI built into the plug of the power supply cord. This device provides additional protection from the risk of electrical shock. (Figure 1)

FLOW RATE: This is the amount of water that passes through your wand. (Usually measured in G.P.M., gallons per minute.).

IDLE MODE: This pertains to the time that the pressure washer is running without the trigger on the wand engaged to spray. You should never run this pressure washer for more than 5 minutes without pulling the trigger to relieve pressure. Running the pressure washer in this manner would void your warranty.

⚠ CAUTION

Operating unit with water supply shut off (without flow of water) will result in equipment damage.

KICK START: There is a tendency on new units or units that have not been used for awhile for the motor to "Hum" briefly on start-up followed by the Trip-out of the GFCI, sometimes repeatedly. This is not a defect in the unit. Once the unit has run awhile it can be restarted without incident. A "Kick Start" procedure should be performed on any new unit or units that have not been operated for awhile.

⚠ WARNING This is done by disconnecting the power cord and turning the motor shaft by inserting a large blade straight slot screw driver into the slot located in the shaft at the rear of the unit (Figure 2). Turn the shaft two or three times to free any seals that might be stuck.

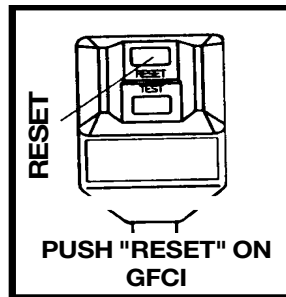

Figure 1

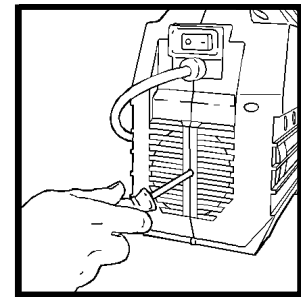

Figure 2

GROUNDING INSTRUCTIONS & EXTENSION CORDS

GROUNDING: This product must be grounded. If it should malfunction or breakdown, grounding provides a path of least resistance for electric current to reduce the risk of electric shock. This product is equipped with a cord having an equipment-grounding conductor and a grounding plug. The plug must be plugged into an appropriate outlet that is properly installed and grounded in accordance with all local codes and ordinances.

⚠ DANGER

Improper connection of the equipment-grounding conductor can result in a risk of electrocution. Check with a qualified electrician or service personnel if you are in doubt as to whether the outlet is properly grounded. Do not modify the plug provided with the product—if it will not fit the outlet, have a proper outlet installed by a qualified electrician. Do not use any type of adaptor with this product.

GROUND FAULT CIRCUIT INTERRUPTER PROTECTION: This washer is provided with a ground fault circuit interrupter (GFCI) built into the plug of the power supply cord. This device provides additional protection from the risk of electric shock. Should replacement of the plug or cord become necessary, use only identical replacement parts that include GFCI protection.

EXTENSION CORDS: Extension cords are **NOT** recommended to be used with product. If an extension cord must be used, the following 3 requirements should be met:

1. 14 gauge minimum wire size up to 25 ft. cord.
2. 12 gauge minimum wire size up to 50 ft. cord.
3. Use only 3-wire extension cords that have 3-prong grounding—type plugs and 3-pole cord connectors that accept the plug from the product. Use only extension cords that are intended for outdoor use.

These extension cords are identified by a marking "Acceptable for use with outdoor appliances; store indoors while not in use." Use only extension cords having an electrical rating not less than the rating of the product. Do not use damaged extension cord and do not yank on any cord to disconnect. Keep cord away from heat and sharp edges. Always disconnect the extension cord from the receptacle before disconnecting the product from the extension cord. Extension cord must be connected to a grounded outlet equipped with a GFCI (Ground Fault Circuit Interrupter). There is a risk of Electrocution if extension cord is not connected to a grounded outlet equipped with a GFCI.

⚠ WARNING

To reduce the risk of electrocution, keep all connections dry and off the ground. Do not touch plug with wet hands. Do not use if cord is damaged.

OPERATING INSTRUCTIONS

⚠ WARNING

READ AND UNDERSTAND ALL WARNINGS AND INSTRUCTIONS IN THIS MANUAL BEFORE OPERATING.

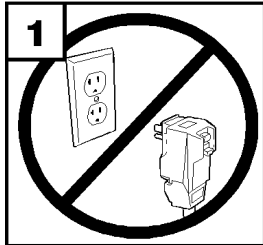

1 DO NOT CONNECT TO ELECTRICAL OUTLET UNTIL YOU HAVE READ INSTRUCTIONS.

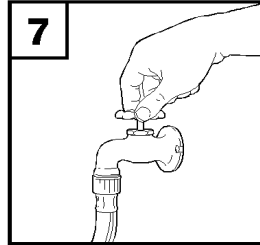

TURN ON WATER.

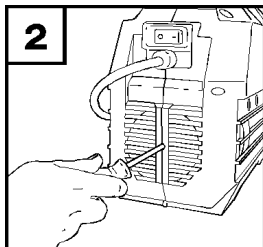

2 FOR INITIAL START-UP AND AFTER EXTENDED STORAGE: WITH UNIT UNPLUGGED, ROTATE MOTOR SHAFT SEVERAL TIMES WITH A FLATHEAD SCREWDRIVER THROUGH HOLE IN COVER.

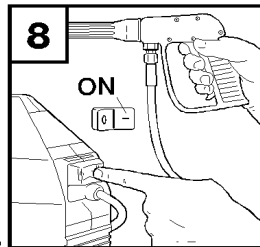

⚠ WARNING: DO NOT POINT WAND AT SELF OR OTHERS. WITH WAND TRIGGER PULLED, PUSH START BUTTON ON WASHER.

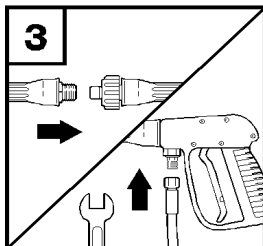

3 CONNECT WAND TO GUN AND HAND TIGHTEN. CONNECT HIGH PRESSURE HOSE TO GUN BODY AND TIGHTEN WITH WRENCH.

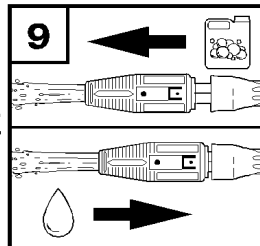

⚠ WARNING: KEEP HAND AWAY FROM SPRAY. ADJUST LOW-HI PRESSURE AT NOZZLE. PUSH NOZZLE FORWARD TO SIPHON SOAPS AND CLEANERS. PULL NOZZLE BACK FOR HIGH PRESSURE WATER SPRAY.

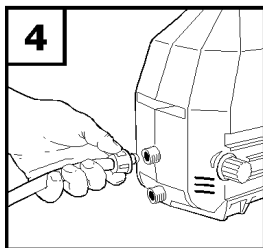

4 CONNECT HIGH PRESSURE HOSE TO WASHER AND HAND TIGHTEN.

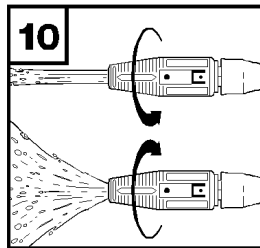

ADJUST SPRAY PATTERN FROM WIDE TO NARROW BY ROTATING NOZZLE.

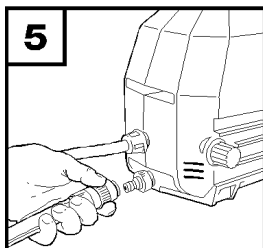

5 CONNECT GARDEN HOSE TO WASHER USING QUICK CONNECT SUPPLIED WITH UNIT.

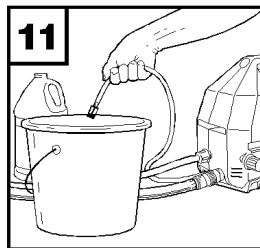

FOR LIQUID SOAPS AND CLEANERS, PULL SUCTION TUBE OUT FROM WASHER HOUSING AND PLACE IT IN YOUR LIQUID CONTAINER. PUSH THE WAND NOZZLE FORWARD TO SIPHON LIQUID.

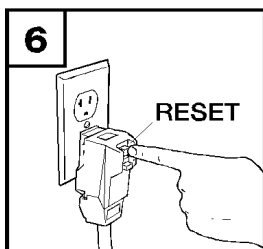

6 PLUG GFCI INTO 120 VOLT-15 AMP CIRCUIT. PUSH "RESET" BUTTON ON GFCI PLUG.

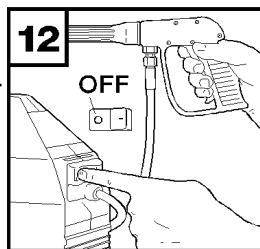

WHEN YOU ARE FINISHED SPRAYING, TURN WASHER OFF AND PULL WAND TRIGGER TO RELEASE PRESSURE. DO NOT ALLOW WASHER TO RUN FOR MORE THAN **5 MINUTES** WITHOUT PULLING TRIGGER.

MAINTENANCE AND STORAGE

⚠ WARNING

ALWAYS DISCONNECT THE PLUG FROM THE ELECTRICAL SUPPLY BEFORE ANY MAINTENANCE IS STARTED.

MAINTENANCE

1. **WATER SCREEN:**

Inspect the water screen before attaching water supply. Clean water screen if dirty.

2. **SIPHON HOSE:**

If the siphon tube is used for detergent or wax remove and place in a container of clean water. Run clean water through the unit to flush any detergent or wax from the pressure washer.

3. **NOZZLE CLOGGED:**

A clogged nozzle will cause the operating pressure to be too high causing the pressure washer to surge. If this happens:

1. Unplug power supply, pull trigger on gun handle to relieve pressure, remove wand assembly from gun assembly.

2. Clean the nozzle with the nozzle cleaning kit.

3. Flush wand assembly backwards with water or compressed air.

4. If pressure is still too high, repeat steps 1-3.

4. **LUBRICATION:**

No lubrication is required for this pump.

⚠ WARNING

HIGH PRESSURE HOSE: Damaged high pressure hoses can burst which can cause a potentially hazardous situation. High pressure hoses should not be kinked, crushed, twisted, or damaged in any way. Replace high pressure hose should this occur.

STORAGE

This pressure washer should be stored in such a way to protect it from freezing. **Do not** store this unit outdoors or in an area where temperatures will fall below 32°F. This can cause extensive damage to this unit. Drain as much water as possible as follows:

1. Stop the pressure washer, detach the water hose, and pull the trigger on the spray handle to release the pressure in the inlet hose.
2. Restart the unit, pull the trigger, and run until water no longer sprays out of the nozzle. (Approximately 30 seconds)
3. Stop unit. Detach high pressure hose from unit. Leave hose attached to wand to protect it against accidental dropping. Pull trigger to drain water from wand and hose, and place assembly in storage.

*If unit has to be stored under freezing conditions a non-toxic R.V. anti-freeze can be used to protect from freezing.

Add anti-freeze as follows:

1. Be sure the unit is turned off, the water supply hose is disconnected, and pressure has been relieved from the gun. **Do not** disconnect the high pressure hose or gun.
2. Tip the unit on end with the water inlet fitting pointing upward, and start the motor.
3. Pour approx. 1/4 cup of non-toxic R.V. anti-freeze down the plastic fitting where the water hose attaches while the motor is running (See Figure 3 below). Let unit run for a few seconds.
4. Turn the unit off and pull the trigger on the gun to relieve any pressure from the hose and gun.
5. After removing the high pressure hose, restart the unit to displace any water remaining in the pump.

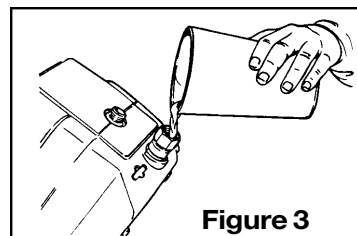

TROUBLESHOOTING GUIDE

PROBLEM	CAUSE	REMEDY
Motor will not start and there is no humming sound	<ol style="list-style-type: none"> 1. Not plugged in. 2. "RESET" button on GFCI not pushed. 3. Circuit breaker has tripped or fuse is blown. 	<ol style="list-style-type: none"> 1. Plug in. 2. Push "RESET" button. 3. Reset breaker or replace fuse.
Power source circuit continues to trip or blow fuses	<ol style="list-style-type: none"> 1. Too much load already on circuit. 	<ol style="list-style-type: none"> 1. Reduce load on circuit. 2. Try another 15 amp circuit.
Motor hums but will not start	<ol style="list-style-type: none"> 1. Extension cord is too long or of improper gauge, causing voltage drop. 2. Pump is stuck due to dirt, mineral build up, or ice. 3. Motor malfunction 	<ol style="list-style-type: none"> 1. See section on extension cords (See page 6). 2. Unplug unit. If temp is below freezing do not use. Thaw in a warm area. Turn motor manually by "Kick Start". (See page 6) 3. Take to authorized service center (See page 2)
No low pressure detergent delivery	<ol style="list-style-type: none"> 1. Nozzle set on high pressure. 2. Siphon hose or filter is plugged. 	<ol style="list-style-type: none"> 1. Push nozzle forward. 2. Unplug siphon hose.
Unit does not reach required pressure	<ol style="list-style-type: none"> 1. Restricted, or insufficient water supply. 2. Unsuitable or worn out nozzle. 	<ol style="list-style-type: none"> 1. Check supply hose, faucet and inlet screen. Must be connected to water source which provides 1.8 gal. water per minute. 2. Replace nozzle.
Unit is noisy	<ol style="list-style-type: none"> 1. Restricted, insufficient water supply, or air in the water line. 2. Water temperature is too high. 3. Pump has operated more than 5 minutes, without pulling trigger. 4. Pump sucking air. 	<ol style="list-style-type: none"> 1. Check supply hose, faucet, and inlet screen. 2. Do not use water from a hot water source, use water only from a cold water faucet. 3. Pull trigger at least 30 seconds every 5 minutes. 4. Check suction manifold.
Pressure fluctuates without opening gun	<ol style="list-style-type: none"> 1. Water leak in high pressure fittings, hose, or gun. 	<ol style="list-style-type: none"> 1. Use teflon tape or pipe sealant to tighten hose fitting, replace hose or gun. If problem continues take to authorized service center.

ACCESSORIES/CLEANING SOLUTIONS/SERVICE PARTS

HIGH PRESSURE ROTARY NOZZLE PART NUMBER WA100

- Fits DeVilbiss pressure washer wands
- High pressure rotating spray for maximum cleaning
- Durable stainless steel nozzle
- Brass thread connections eliminate leakage

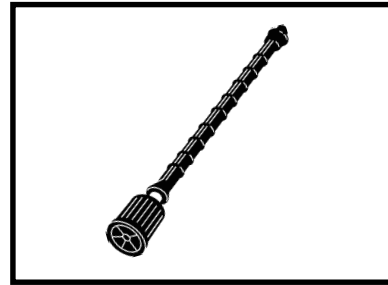

ANGLE ROTARY BRUSH KIT PART NUMBER WA200

- Fits DeVilbiss pressure washer wands
- 7 in. dia. nylon brush with rotating brush
- Adjustable- for angled surfaces
- Adjustable- for angled use
- 2 ft. extension for added reach
- Low pressure adapter included

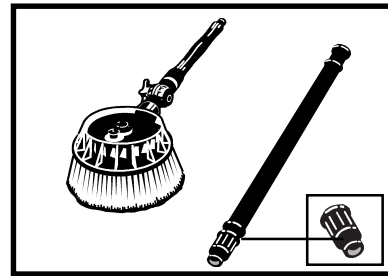

FIXED BRUSH KIT PART NUMBER WA250

- Fits DeVilbiss pressure washer wands
- 7 in. x 3 in. soft nylon bristles
- Tapered for cleaning in tight spots
- 2 ft. extension for added reach
- Low pressure adapter included

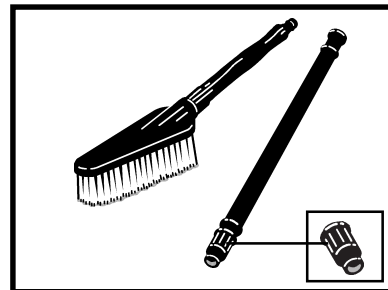

FLUID HOSE (50' length, 5/16" I.D.) PART NUMBER WA300

- Fits DeVilbiss pressure washers
- Replacement for 25 ft. hose
- 50 ft. x 5/16 in. high pressure hose
- Swivel fittings for easy connection



ACCESSORIES/CLEANING SOLUTIONS/SERVICE PARTS

HEAVY DUTY DEGREASER
(1 gallon pre-mixed)
PART NUMBER WA401

- For use with DeVilbiss pressure washers
- Cuts through grease and oil
- Removes grease, oil, and other tough stains
- Ideal for cleaning engines, grills, and farm equipment
- Pre-mixed – ready to use
- One U.S. gallon (3.79L)



GENERAL PURPOSE CLEANER
(1 gallon pre-mixed)
PART NUMBER WA400

- For use with DeVilbiss pressure washers
- Removes dirt and mildew without abrasives
- Ideal for cleaning house exteriors, automobiles, and more
- Pre-mixed – ready to use
- Biodegradable
- One U.S. gallon (3.79L)

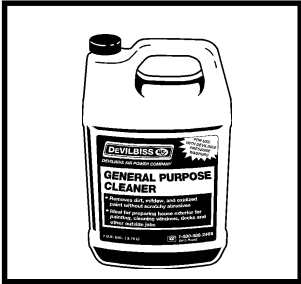

MOBILE CART
PART NUMBER WA500

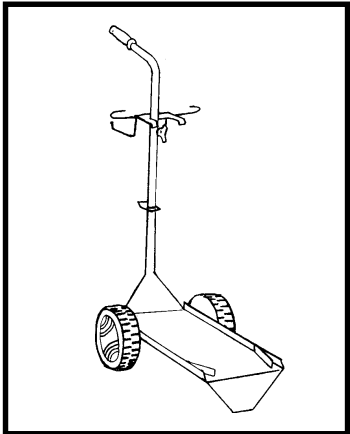

SERVICE PARTS	
PW-0038	1/4"x25' High Pressure Hose
PW-0024	Pressure Washer Gun
PW-0025	Wand/Nozzle
PW-0021	Quick Disconnect Coupler

**OWNERS MANUAL
FOR DeVILBISS
PRESSURE WASHER**

**MODEL NO.
W1218**

Attach Sales Receipt Here.
Retain Original Sales Receipt as
Proof of Purchase for Warranty
Repair Work.

WARRANTY

This product is covered by the
DeVilbiss one year limited warranty
(SP-100-E). The warranty can be
found on page 3 or is available
upon request.

Call our **Toll Free Number 1-800-888-2468, Ext 2**, to obtain the location
of the nearest Authorized Service Center for ordering repair parts and
for warranty repairs.

When ordering repair parts from your local Authorized Service Center,
always give the following information:

- Model number of your product
- Part number and description of the item you wish
to purchase